



Owner's Manual

2014 Audi A8 | S8

Audi
Vorsprung durch Technik



2014 Audi A8

2014 Audi S8

Foreword

Thank you for choosing an Audi - we value your trust in us.

Your new Audi will allow you to experience the best in groundbreaking technology and premium quality equipment a vehicle has to offer. We recommend that you read your Owner's Manual thoroughly so that you quickly become acquainted with your Audi and make use of all of its features.

In addition to explaining how the different features work, we provide many useful tips and information concerning your safety, how to care for your vehicle and how to maintain your vehicle's value. We also give you useful tips and information on how to drive your vehicle more efficiently and in an environmentally friendly manner.

In the Owner's Manual packet, you will also find a quick reference guide, an Owner's Manual for your Infotainment system and the vehicle maintenance schedule.

We hope you enjoy driving your Audi and we wish you safe and pleasant motoring.

AUDI AG



1425614H021

Vehicle literature	5	Warm and cold	79
		Climate controls	79
About this Owner's Manual ...	6		
		On the road	83
Controls and equipment	8	Steering	83
Instruments and controls	8	Starting and stopping the engine ...	84
General illustration	8	Electromechanical parking brake ...	86
		Start-Stop-System	88
		Speed warning system	91
		Cruise control	91
Instruments and warning/ indicator lights	10		
Instruments	10	Audi adaptive cruise control and braking guard	94
Warning/indicator lights	11	Introduction	94
Driver information display	24	General information	94
On-Board Diagnostic system (OBD) ...	29	Audi adaptive cruise control	96
		Audi braking guard	100
		Messages	101
Opening and closing	31		
Keys	31	Audi lane assist	103
Power locking system	33	Lane assist	103
Luggage compartment lid	37		
Child safety lock	41	Audi side assist	106
Power windows	41	Lane Change Assistant	106
Valet parking	42		
Sliding/tilting sunroof	43	Audi drive select	110
Panoramic sunroof	44	Driving settings	110
		Raising/lowering the vehicle	112
		Driver messages	112
Clear vision	46		
Lights	46	Night vision assistant	113
Interior lights	50	Description	113
Vision	51	Pedestrian detection	113
Wiper and washer system	53	Pedestrian warning	113
Mirrors	55	General information	114
Digital compass	56	Switching on and off	114
		Settings in the MMI	115
		Driver messages	115
Seats and storage	58		
General recommendations	58	Automatic Transmission	116
Front seats	59	tiptronic (8-speed transmission)	116
Rear seats	61		
Head restraints	65	Parking systems	122
Seat memory	66	General information	122
Full-length center console	68	Advanced parking system with rear view camera	123
Luggage compartment	70	Peripheral cameras	127
Pass-through with ski sack	71		
Roof rack	72		
12-volt sockets	74		
Storage	75		
Cooler	76		

Adjusting the display and the warning tones	132	Braking	201
Error messages	132	Servotronic - advanced power steering system	203
Trailer hitch	132	Driving with your quattro	204
HomeLink	133	Energy management	204
Universal remote control	133	Driving and environment	207
Safety first	135	The first 1,000 miles (1,500 km) and afterwards	207
Driving Safely	135	Catalytic converter	208
General notes	135	Diesel particulate filter	208
Proper occupant seating positions	136	Shutting down vehicle	209
Driver and passenger side footwell	140	Avoid damaging the vehicle	209
Pedal area	140	Driving through water on roads	209
Stowing luggage	141	Operate your vehicle economically and minimize pollution	209
Reporting Safety Defects	143	Trailer towing	212
Safety belts	145	Driving with a trailer	212
General notes	145	Trailer towing tips	214
Why safety belts?	146	Vehicle care	216
Safety belts	148	Vehicle care and cleaning	216
Safety belt pretensioners	151	General information	216
Airbag system	153	Car washes	216
Important things to know	153	Cleaning and care information	217
Front airbags	157	Fuel supply and filling your fuel tank	222
Monitoring the Advanced Airbag System	164	Gasoline	222
Knee airbags	168	Diesel fuel	223
Side airbags	171	Fuel tank	224
Side curtain airbags	174	Selective catalytic reduction	227
Child Safety	177	Checking and filling	231
Important things to know	177	Engine hood	231
Child safety seats	183	Engine compartment	233
Installing a child safety seat	187	Engine oil	234
LATCH Lower anchorages and tethers for children	190	Engine cooling system	239
Additional Information	196	Brake fluid	242
Audi pre sense	197	Battery	243
Preventative passenger protection	197	Windshield/headlight washer container	247
Vehicle operation	199	Tires and wheels	248
Intelligent technology	199	Tires	248
Notice about data recorded by vehicle control modules	199	Tire pressure monitoring system	266
Electronic Stabilization Control (ESC)	199		

Do-it-yourself service	269
What do I do now?	269
Trunk escape handle	269
Emergency warning triangle	269
Vehicle tool kit	270
Changing a wheel	272
Fuses and bulbs	278
Fuses	278
Bulbs	282
Emergency situations	283
General	283
Starting by pushing or towing	283
Starting with jumper cables	283
Use of jumper cables	284
Emergency towing with commercial tow truck	285
Lifting vehicle	287
Technical data	289
Technical Data	289
Vehicle identification	289
Weights	289
Dimensions	290
Capacities	290
Gasoline engines	291
Diesel engine	291
Consumer Information	292
Warranty coverages	292
Operating your vehicle outside the U.S.A. or Canada	292
Audi Service Repair Manuals and Literature	292
Maintenance	292
Additional accessories, modifications and parts replacement	294
Declaration of Compliance, Telecommunication or Electronic Systems	295
Index	297

In addition to this Owner's Manual, your Audi comes with the

- MMI Operating Instructions
- Warranty & Maintenance booklet.

If you are missing one of these publications, or if you believe that the information is not complete, contact your authorized Audi dealer for assistance.

MMI Operating Instructions

contain detailed description of the Audi Multi Media Interface (MMI) including the navigation system, the sound system and the hand-held phone.

The Warranty & Maintenance booklet

explains how you can keep your Audi in top driving condition by having it serviced regularly and contains detailed information about the warranties covering your Audi. Always have the booklet with you when you take your vehicle to an authorized Audi dealer for service. Your Audi Service Advisor will record each scheduled service and can answer any questions you may have regarding how to maintain your vehicle.

In Canada,

the vehicle literature is also available in French. To obtain a copy, contact your dealer or write to:

Au Canada, on peut se procurer un exemplaire en français de ce document auprès du concessionnaire ou de:

Volkswagen Canada Inc.
Client Assistance
Assistance a la Clientele
777 Bayly Street, West,
Ajax, Ontario L1S 7G7

If you sell your Audi

all literature should be left in the vehicle to make the Warranty terms as well as all operating, safety and maintenance information available to the next owner.

If you change your address or if you bought this Audi used

be sure to send in a "Notice of Address Change" / "Notice of Used Car Purchase" post card. This card can be found in the Warranty & Maintenance booklet or obtained from your authorized Audi dealer.

It is in your own interest that we are able to contact you should the need arise.

This owner's manual contains important information, tips, suggestions, and warnings for the use of your vehicle.

Make sure that this owner's manual is always located in the vehicle. This is especially important if you allow other people to drive the vehicle, or if you sell it.

This owner's manual describes the **equipment range** specified for this model at the editorial deadline date. Some of the equipment described here will only be available at a later date, or only in specific markets.

Some sections in this owner's manual do not apply to all vehicles. In that case, the **range of applicability** is given at the beginning of the section, e. g. "Applies to vehicles: with Advanced Parking System". In addition, optional or vehicle-specific equipment is indicated by an asterisk "*".

Illustrations may be different from those in your vehicle, and are intended to be viewed as a basic guide.

You will find a **table of contents** at the beginning of this book, which displays all topics described in this manual in order of appearance. You will find an alphabetical **index** at the end of this book.

All **directions**, such as "left", "right", "front", "back", are relative to the direction of travel.

- * Optional or vehicle-specific equipment
- This section continues on the next page.

⇒ ⚠ Cross-reference to a "WARNING!" within a section. For indication with a page number, the corresponding "WARNING!" can be found outside of the section.

WARNING

Text with this symbol contains important information on safety and how to reduce the risk of personal injury or death.

Note

Text with this symbol draws your attention to potential sources of damage to your vehicle.

For the sake of the environment

Text with this symbol contains information about the environment and how you can help protect it.

Tips

Text with this symbol contains special tips and other information about getting the most out of your vehicle and its features.

Instruments and controls

General illustration

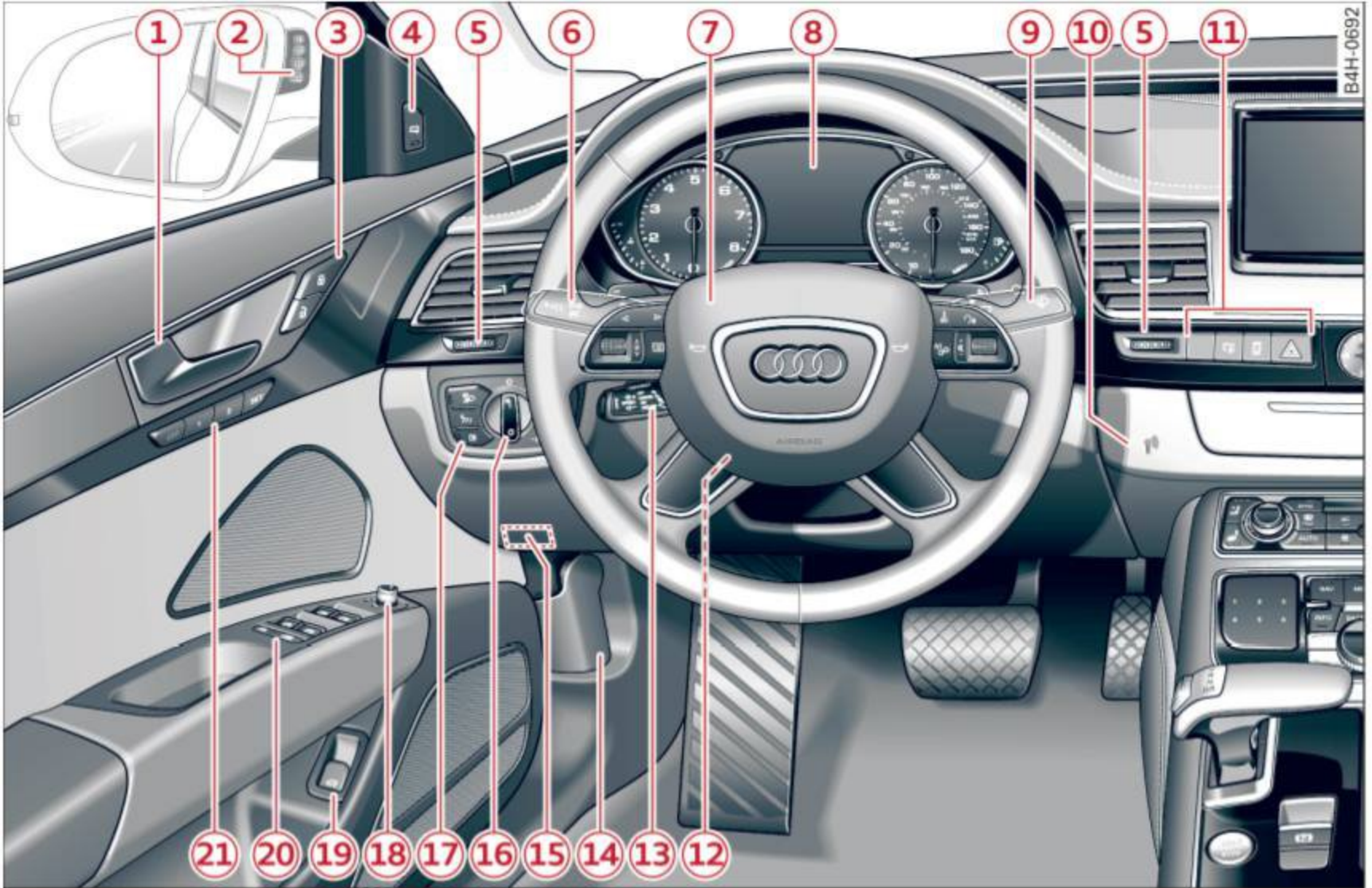

Fig. 1 Cockpit: left section

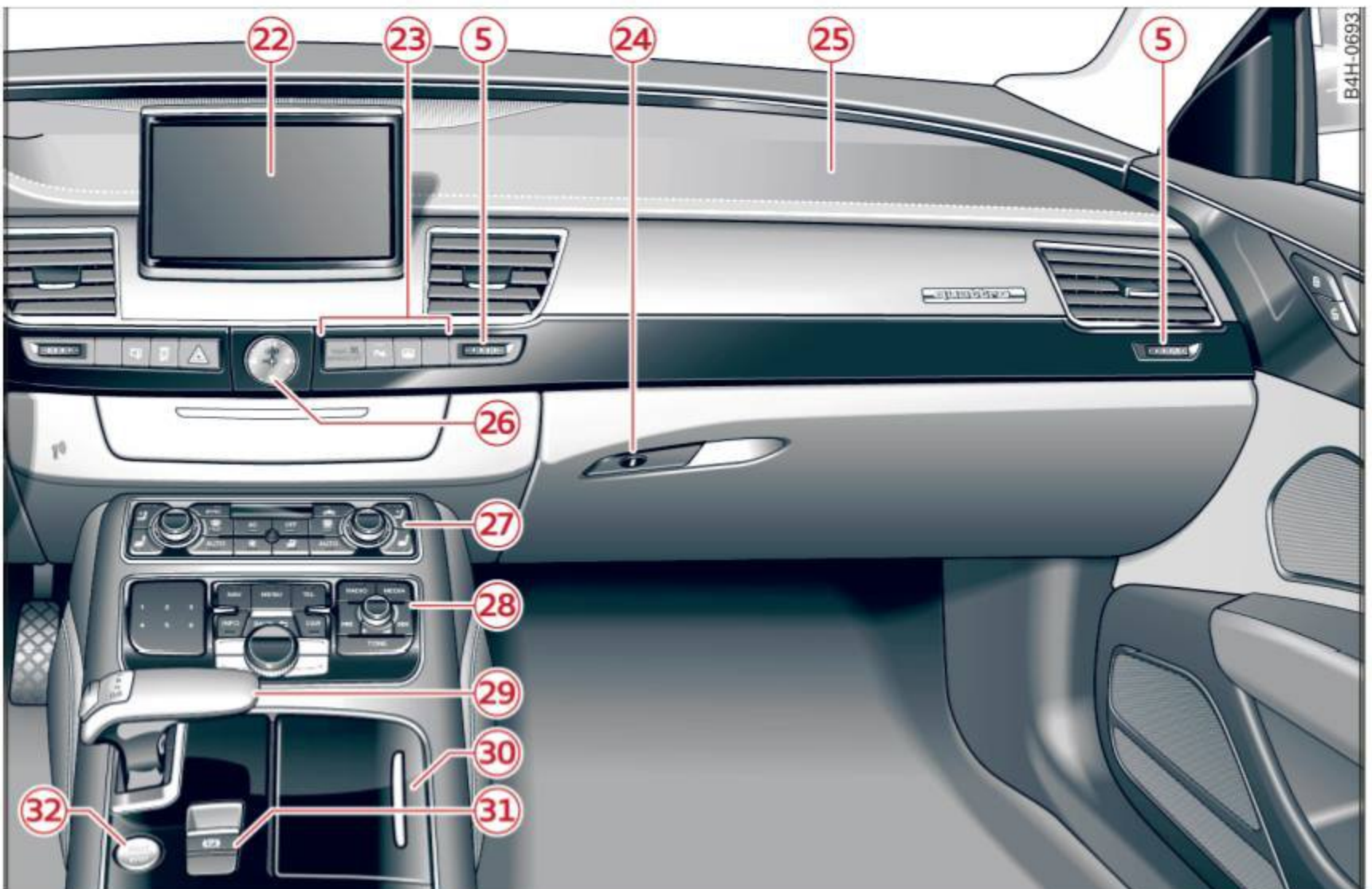

Fig. 2 Cockpit: right section

① Door handle		⑱ Power exterior mirror adjustment	55
② Audi side assist display	106	⑲ Rear lid switch	37
③ Power locking switches	36	⑳ Power windows	41
④ Audi side assist button	106	㉑ Memory function buttons	66
⑤ Air vents with thumbwheel		㉒ MMI display	
⑥ Control lever for:		㉓ Indicator lights/buttons for	
– Turn signal and high beam	48	– PASSENGER AIR BAG OFF	164
– Audi lane assist	103	– Parking system	122
⑦ Multifunction steering wheel with:		– Rear window power sun shade	52
– Horn		㉔ Glove compartment	76
– Driver's airbag	157	㉕ Front passenger's airbag	157
– Driver information system buttons	24	㉖ Analog clock	27
– Audio/video, telephone, navigation and voice recognition buttons		㉗ Climate controls	80
– Shift paddles	119	㉘ MMI controls	
⑧ Instrument cluster	10	㉙ Selector lever (automatic transmission)	116
⑨ Windshield washer system lever	53	⑳ Center console with cupholder	75
⑩ Starting the engine if there is a malfunction	86	㉑ Electromechanical parking brake	86
⑪ Buttons for:		㉒ START ENGINE STOP button	84
– Start-Stop-System	88		
– MMI display			
– Electronic Stabilization Control (ESC)	201		
– Emergency flashers	47		
⑫ Buttons for:			
– Steering wheel adjustment	83		
– Steering wheel heating	82		
⑬ Lever for:			
– Cruise control system	91		
– Adaptive cruise control	94		
⑭ Engine hood release	231		
⑮ Data Link Connector for On Board Diagnostics (OBD II)	29		
⑯ Light switch and instrument illumination	46, 51		
⑰ Buttons for:			
– All-weather lights	46		
– Night vision assistant	113		
– Rear fog lights	46		

i Tips

- Some of the equipment or features shown in the general illustration may be standard equipment on your vehicle or may be optional equipment depending on your model. Always ask your authorized Audi dealer if you have a question about your vehicle.
- Operation of the Multi Media Interface (MMI) is described in a separate manual.

Instruments and warning/indicator lights

Instruments

Instrument cluster and controls

The instrument cluster is your central source of information.



Fig. 3 Overview of the instrument cluster

①	Coolant temperature gauge . . .	10
②	Tachometer (engine rev counter) .	11
③	Turn signals	48
④	Display with	
	– Driver information system . . .	24
	– Warning/indicator lights	11
⑤	Tachometer	
⑥	Fuel gauge	11
⑦	Reset button for trip odometer	27

i Tips
 The instrument illumination (for dials and needles) turns on when the ignition is on and the vehicle lights are turned off. As the daylight fades, the illumination of the dials likewise dims automatically and will go out completely when the outside light is very low. This feature is meant to remind

you to switch on the headlights when outside light conditions become poor.

Engine coolant temperature gauge



The engine coolant gauge ① ⇒ page 10, fig. 3 only works when the ignition is on. To prevent damage to your engine, please note the following important points:

Engine cold

If only the LEDs at the bottom of the gauge turn on, the engine has not reached operating temperature yet. Avoid high engine speeds, heavy engine loads and heavy throttle applications.

Normal temperature

The engine has reached its operating temperature once the LEDs up to the center of the

gauge turn on under normal driving conditions. The LEDs higher up may turn on when the engine is under heavy load or the exterior temperature is high. This is no need to worry as long as the  warning light in the instrument cluster does not illuminate. If the LEDs in the upper area of the display and the indicator light  in the instrument cluster display turn on, the coolant temperature is too high ⇒ *page 16*.

WARNING

- Always observe the warning in ⇒ *page 231, Working in the engine compartment*, before opening the hood and checking the engine coolant level.
- Never open the engine hood if you see or hear steam, or if you see engine coolant dripping from the engine compartment. You could burn yourself. Let the engine cool off first so that you cannot hear or see any steam or engine coolant.

Note

- Mounting additional lights or accessories in front of the air inlets reduces the cooling effect of the radiator. At high outside temperatures or high engine load, the engine could overheat.
- The front spoiler has been designed to properly distribute the cooling air when the vehicle is moving. If the spoiler is damaged, this could reduce the cooling effect and the engine could then overheat. Ask your authorized Audi dealer for assistance.

Tachometer (engine rev counter)

The tachometer indicates the engine RPM (revolutions per minutes).

If engine RPM drops below 1,500, you should downshift to the next lower gear. The red area at the end of the scale indicates maximum permissible engine RPM after the break-in period. Before reaching this area, move the selector lever to position “D (Drive)” or ease your foot off the accelerator pedal.

Note

The tachometer needle should only briefly be in the red zone: you could damage your engine! The beginning of the red zone varies depending on the engine.

For the sake of the environment

Upshifting early saves fuel and reduces engine noise.

Fuel gauge

The fuel gauge only works when the ignition is on. If the fuel level drops below 4 gallons (15 liters), the bottom LED turns red and the indicator light  turns on ⇒ *page 21*. The bottom LED blinks red when the fuel level is very low.

The possible range based on the current fuel level is shown in tab  ⇒ *page 24, fig. 4*.

Note

Never run the tank completely dry. An irregular supply of fuel can cause engine misfiring and fuel could enter the exhaust system. The catalytic converter could then overheat and be damaged.

Warning/indicator lights

Description

The indicator lights in the instrument cluster blink or turn on. They indicate functions or malfunctions ⇒ .

Messages may appear with some indicator lights. A warning signal will sound at the same time. The indicator lights and messages in the center of the displays may be replaced by other displays. To show them again, select the tab for indicator lights and messages using the multifunction steering wheel ⇒ *page 24*. If there are several malfunctions, you can display them one at a time using the thumbwheel.

Some indicators lights in the display can turn on in several colors.

! WARNING

- Failure to heed warning lights and other important vehicle information may result in serious personal injury or vehicle damage.
- Whenever stalled or stopped for repair, move the vehicle a safe distance off the road, stop the engine, and turn on the emergency flasher ⇒ *page 47*.
- The engine compartment of any motor vehicle is a potentially hazardous area. Before you check anything in the engine compartment, stop the engine and let it cool down. Always exercise extreme caution when working under the hood ⇒ *page 231, Working in the engine compartment*

i Tips

Malfunctions or faults will be identified either with a red symbol (priority 1 - Danger!) or with a yellow symbol (priority 2 - Warning).

















Overview

Some indicator lights turn on briefly to check the function of that system when you switch the ignition on. These systems are marked with an ✓ in the following tables. If one of these indicator lights does not turn on, there is a malfunction in that system.

Red indicator lights

Red symbols indicate a priority malfunction - Danger!

- Pull off the road.
- Stop the vehicle.
- Turn off the engine.
- Check the malfunctioning system. Contact your authorized Audi dealer or a qualified workshop for assistance.

	USA models: Brake malfunction ✓ ⇒ <i>page 14</i>
	Canada models: Brake malfunction ✓ ⇒ <i>page 14</i>
	USA models: Electromechanical parking brake ⇒ <i>page 15</i>
	Canada models: Electromechanical parking brake ⇒ <i>page 15</i>
	Engine cooling system ⇒ <i>page 16</i>
	Engine oil pressure ⇒ <i>page 17</i>
	Engine oil level ⇒ <i>page 17</i>
	Battery ⇒ <i>page 16</i>
	Safety belt ⇒ <i>page 16</i>
	Electronic steering column lock ⇒ <i>page 17</i>
	Engine start system ⇒ <i>page 18</i>
	Central indicator light ⇒ <i>page 18</i>
	USA models: Speed warning system ⇒ <i>page 91</i>
	Canada models: Speed warning system ⇒ <i>page 91</i>
	Adaptive cruise control ✓ ⇒ <i>page 96</i>
	Air suspension* ⇒ <i>page 18</i>
	Pedestrian warning* ⇒ <i>page 113</i>

 Refill AdBlue*
⇒ page 227

 AdBlue malfunction*
⇒ page 227

Yellow indicator lights

Yellow symbols indicate a priority 2 malfunction - Warning!

 **USA models:** Safety systems
⇒ page 18

 **Canada models:** Safety systems
⇒ page 18

 Electronic Stabilization Control (ESC) ✓
⇒ page 18

 Electronic Stabilization Control (ESC) ✓
⇒ page 18

 **USA models:**
Anti-lock braking system (ABS) defective
⇒ page 19



 **Canada models:**
Anti-lock braking system (ABS) defective
⇒ page 19

 Worn brake pads
⇒ page 20

 Electromechanical parking brake
⇒ page 86

 Tire pressure monitoring system ✓
⇒ page 266

 **TPMS** Tire pressure monitoring system
⇒ page 266

 **EPC** Electronic power control (alternative to )
⇒ page 20

 Glow plug system (alternative to **EPC**)
⇒ page 20

 Malfunction indicator Lamp (MIL) ✓
⇒ page 20

 Diesel particulate filter* clogged
⇒ page 21

 Engine speed limitation
⇒ page 21

 Engine oil level
⇒ page 17

 Engine oil sensor
⇒ page 21

 Battery
⇒ page 16

 Tank system
⇒ page 21

 Windshield washer fluid level
⇒ page 21

 Windshield wipers
⇒ page 22

 Remote control key
⇒ page 84

 Remote control key
⇒ page 84

 Battery in remote control key
⇒ page 32

 Defective light bulb warning
⇒ page 22











 Fog lights*
⇒ page 22

 Rear fog lights*
⇒ page 22







 Headlight range control
⇒ page 22



 adaptive light*
⇒ page 22

 Light-/rain sensor faulty
⇒ page 22

	Audi lane assist* ⇒ page 103
	Transmission ⇒ page 120
	Transmission ⇒ page 120
	Electronic steering column lock ⇒ page 17
	Engine start system ⇒ page 18
	Central indicator light ⇒ page 18
	Dynamic steering* ✓ ⇒ page 22
	Air suspension* ⇒ page 18
	Sport differential* ⇒ page 23
AdBlue 	Refill AdBlue* ⇒ page 227
AdBlue 	AdBlue malfunction* ⇒ page 227

Other indicator lights

	Turn signals ⇒ page 23
CRUISE	USA models: Cruise control* ⇒ page 91
	Canada models: Cruise control* ⇒ page 91
	Adaptive cruise control* ⇒ page 96
	Adaptive cruise control* ⇒ page 96
	Adaptive cruise control* ⇒ page 96
	Audi lane assist* ⇒ page 103

	Start-Stop-System* ⇒ page 88
	Start-Stop-System* ⇒ page 88
	High beam ⇒ page 48

BRAKE /  Brake system

The light illuminates when the ignition is switched on. It goes out after the engine has been started. This indicates that the brake warning light is functioning properly.

If the brake warning light does not light up when the engine is cranking, there may be a malfunction in the electrical system. In this case, contact your Audi dealer.





If the brake system warning/indicator light turns on, there is a brake system malfunction.

BRAKE (USA models) /  (Canada models) Stop vehicle and check brake fluid level

If the indicator light turns on and the message appears, proceed as follows:

- ▶ Pull off the road.
- ▶ Stop the vehicle.
- ▶ Turn off the engine.
- ▶ Check the brake fluid level ⇒ page 242.
- ▶ Contact your nearest authorized repair facility if necessary.

Warning! Fault in brake system. Contact dealer

If the ABS indicator light  (USA models) /  (Canada models), the ESC indicator light  and the brake system indicator light **BRAKE** (USA models) /  (Canada models) turn on and the message appears, the ABS, ESC and braking distribution are not working ⇒ .

Carefully drive to your authorized Audi dealer immediately to have the malfunction corrected ⇒ .

BRAKE (USA models) /  (Canada models)
Parking brake: system fault! Please contact dealer

- If the indicator light and the message appear **when stationary or after switching the ignition on**, check if you can release the parking brake. After releasing the parking brake, carefully drive to your authorized Audi dealer immediately to have the malfunction corrected. If you cannot release the parking brake, seek professional assistance.
- If the indicator light and the message appear **while driving**, the emergency braking function may not be available. It may not be possible to set the parking brake or release it once it has been set. Seek professional assistance.

(USA models): If the warning light **BRAKE** and the warning light  appear together, immediately contact your authorized Audi dealer or qualified workshop to have all brake pads inspected ⇒ *page 20*.

When the light comes on, an audible warning signal is also given.

 **WARNING**

- Always observe the warnings in ⇒ *page 231*, before opening the hood and checking the brake fluid.
- Driving with low brake fluid is a safety hazard. Stop the car and get professional assistance.
- If the **BRAKE** (USA models) /  (Canada models) brake system indicator light turns on together with the ABS and ESC indicator lights, the ABS/ESC regulating function may have failed. Functions that stabilize the vehicle are no longer available. This could cause the vehicle to swerve and increase the risk of sliding. Drive carefully to the nearest authorized Audi dealer or other qualified workshop and have the malfunction corrected.
- If the brake warning/indicator light does not go out after a few seconds and the parking brake is released, or lights up

while you are driving, the fluid level in the brake fluid reservoir is too low. If you believe that it is safe to do so, proceed immediately at low speed to the nearest authorized Audi dealer or qualified repair facility and have the brake system inspected.

- Always keep in mind that after several brake applications, you will need greater pressure on the brake pedal to stop your vehicle. Do not rely on strained brakes to respond with maximum stopping power in critical situations. You must allow for increased braking distances. The extra distance used up by fading brakes could lead to an accident.

PARK/P  **Electromechanical parking brake**

The warning/indicator light monitors the electromechanical parking brake.

If the indicator light **PARK** (USA models) /  (Canada models) turns on, the parking brake was set. If the parking brake is set when the ignition is off, the indicator light turns off after about 20 seconds.

The warning/indicator light will go out when the parking brake is released.

PARK (USA models) /  (Canada models)
Caution: Vehicle parked too steep

If the indicator light blinks and the message appears, there is not enough braking power to keep the vehicle from rolling. The brakes have overheated. The vehicle could roll away even on a small incline.

Press brake pedal to release parking brake

To release the parking brake, press the brake pedal and press the button  or start driving with starting assist at the same time ⇒ *page 87*.

Please release parking brake

To release the parking brake manually, press the brake pedal and press the button  at the same time. The parking brake only releases

automatically if the driver's safety belt is fastened.

Parking brake!

If the  indicator light turns on and this message appears, there is a parking brake malfunction. Drive to your authorized Audi dealer or qualified workshop immediately to have the malfunction corrected.

Engine cooling system malfunction

A malfunction in the engine cooling system must be repaired as soon as possible.

Switch off engine and check coolant level

If the indicator light turns on and the message appears, the coolant temperature is too high or the coolant level is too low.

- ▶ Pull off the road.
- ▶ Stop the vehicle.
- ▶ Turn off the engine.
- ▶ Check coolant level ⇒ *page 240*.
- ▶ Add coolant if necessary ⇒ *page 240*.
- ▶ Continue driving only after the engine coolant warning/indicator light goes out.
- ▶ Contact your authorized Audi dealer for assistance if necessary.

If the engine coolant level is correct, then the radiator fan may be the cause of the malfunction.

Coolant temperature too high! Please let engine run with vehicle stationary

If the indicator light turns on and the message appears in trailer mode*, let the engine run at idle for a few minutes to cool down.

WARNING

- If your vehicle should break down for mechanical or other reasons, park at a safe distance from moving traffic, turn off the engine and turn on the hazard warning lights ⇒ *page 47, Emergency flasher*.
- Never open the hood if you see or hear steam or coolant escaping from the en-

gine compartment - you risk being scalded. Wait until you can no longer see or hear steam or coolant escaping.

- The engine compartment of any vehicle is a dangerous area. Before you perform any work in the engine compartment, turn off the engine and allow it to cool. Follow the warning stickers ⇒ *page 231*.

Note

Do not continue driving if the  symbol illuminates. There is a malfunction in the engine cooling system – you could damage your engine.

Safety belts

This warning/indicator light reminds you to put on your safety belt.

The  warning/indicator light illuminates when the ignition is switched on to remind the driver and any front passenger to put on the safety belt. Additionally, an acoustic warning (gong) will also sound.

For more Information ⇒ *page 145,  Safety belt warning light*.

Battery

This warning/indicator light detects a malfunction in the generator or in the vehicle's electrical system.

The  warning/indicator light illuminates when you switch on the ignition and must go out after the engine has started.

Alternator fault: Battery is not being charged

If the indicator light turns on and the message appears, there is a malfunction in the generator or vehicle electrical system.

Drive to your authorized Audi dealer or qualified workshop immediately. Because the vehicle battery is discharging, turn off all unnecessary electrical equipment such as the radio. ►

Seek professional assistance if the battery charge level is too low.

Low battery charge: battery will be charged while driving

If the indicator light turns on and the message appears, there may be limited starting ability.

If this message turns off after a little while, the battery charged enough while driving.

If the message does not turn off, have your authorized Audi dealer or qualified workshop correct the malfunction.

Engine oil pressure malfunction



The red engine oil pressure warning symbol requires immediate service or repair. Driving with a low-oil-pressure indication is likely to inflict severe damage to the engine.



Switch off engine and check oil level

If the indicator light turns on and the message appears, the oil pressure is too low.

- ▶ Pull off the road.
- ▶ Stop the vehicle.
- ▶ Turn off the engine.
- ▶ **Check the engine oil level** ⇒ page 236.
- ▶ If the engine oil level is too low, add engine oil ⇒ page 237. Make sure that the oil pressure warning symbol  appears no longer in the display before you start driving again.
- ▶ If the engine oil level is correct and the indicator light still turns on, turn the engine off and do not continue driving. Seek professional assistance.

Tips

- The engine oil pressure symbol  is not an indicator for a low engine oil level. Do not rely on it. Instead, check the oil level in your engine at regular intervals, preferably each time you refuel, and always before going on a long trip.
- The yellow oil level warning indication  requires oil refill or workshop service without delay. Do not wait until the

red oil pressure warning  starts to flash before you respond to the low oil level warning . By then, your engine may already have suffered serious damage.

Engine oil level

WARNING: Please add oil immediately

If the indicator light and the driver message appear, add engine oil immediately ⇒ page 234.

Add oil, max. x qt (l). You may continue driving

When the symbol and the driver message appear, add the amount of oil appearing in the display at the next opportunity ⇒ page 234.

Steering column lock

Do not drive vehicle: Steering defective

If the indicator light turns on and the message appears, there is an electronic steering column lock malfunction. You cannot switch the ignition on.

Do **not** tow your vehicle because it cannot be steered. Seek professional assistance.

Steering lock: system fault. Please contact dealer

If the indicator light turns on and the message appears, there is an electronic steering column lock malfunction.

Drive to your authorized Audi dealer immediately to have the malfunction corrected.

WARNING

Your vehicle must not be towed in the event of a malfunction in the electronic steering column lock because it cannot be steered due to the locked steering. If it is towed with the steering locked, there is the risk of an accident.

Engine start system

Engine start system fault. Please contact dealer

If the indicator light turns on and the message appears, do **not** switch the ignition off because you may not be able to switch it on again.

Drive to your authorized Audi dealer immediately to have the malfunction corrected.

Engine start system fault. Please contact dealer

If the indicator light turns on and the message appears, there is a malfunction in the engine start system.

Drive to your authorized Audi dealer immediately to have the malfunction corrected.

Air suspension

Air suspension: system fault. Can continue slowly with max. 35 mph.

There is a malfunction that can result in restricted driving stability.

Carefully drive at a maximum speed of 35 mph (60 km/h) to your authorized Audi dealer or qualified workshop to have the malfunction corrected.

Air suspension: service mode. Vehicle can only be moved with restrictions

Carefully drive to your authorized Audi dealer or qualified workshop immediately to have the service mode deactivated.

Air suspension fault



There is a system malfunction that can result in restricted driving stability or reduced ground clearance.



Drive to your authorized Audi dealer immediately to have the malfunction corrected.

Air suspension: vehicle too low. Ground clearance reduced

The ground clearance is very low due to a system malfunction. Wait until the air suspension system has restored normal ground clearance. Otherwise, conditions such as an uneven road surface can lead to vehicle damage.

Safety systems

The  (USA models)/ (Canada models) indicator light monitors the safety systems e.g. airbags, pretensioners and illuminates for a few seconds each time you switch the ignition on.

If the  (USA models)/ (Canada models) indicator light does not go out, or if it illuminates while you are driving, or if it starts to blink, then there is a malfunction somewhere in the system. If the light does not illuminate when you switch the ignition on, this also means there is a malfunction.

WARNING

If you have a malfunction in the safety systems, contact your authorized Audi dealer immediately. Otherwise the safety systems may not work properly in an accident.

Central indicator light

If the indicator light  or  turns on, check the message in the instrument cluster.



Electronic Stabilization Control (ESC)

If the  indicator light blinks while driving, the ESC or ASR (Anti-Slip Regulation) is actively regulating.

If the  indicator light turns on, the system has switched the ESC off. In this case, you can switch the ignition off and then on to switch the ESC on again. The indicator light turns off when the system is functioning fully.

If the  indicator light turns on, ESC was restricted using the  button → [page 199](#).

Stabilization control (ESC/ABS): Fault! See owner's manual

If the  indicator light and the ABS indicator light **ABS** (USA models) /  (Canada models) turn on and the message appears, the ABS or electronic differential lock is malfunctioning. This also causes the ESC to malfunction. The brakes still function with their normal power, but ABS is not active.

Drive to your authorized Audi dealer or qualified workshop immediately to have the malfunction corrected.

WARNING

If the **BRAKE** (USA models) /  (Canada models) brake system indicator light turns on together with the ABS and ESC indicator lights, the ABS/ESC regulating function may have failed. Functions that stabilize the vehicle are no longer available. This could cause the vehicle to swerve and increase the risk of sliding. Drive carefully to the nearest authorized Audi dealer or other qualified workshop and have the malfunction corrected.

Tips

For additional information on ESC and ABS, refer to \Rightarrow page 199.

ABS/ Anti-lock braking system (ABS)

This warning/indicator light monitors the ABS and the electronic differential lock (EDL).

The warning/indicator light **ABS** (USA models) /  (Canada models) will come on for a few seconds when the ignition is switched on. The light will go out after an automatic check sequence is completed.

There is a malfunction in the ABS when:

- The warning/indicator light does not illuminate when you switch the ignition on.
- The warning/indicator light does not go out after a few seconds.
- The warning/indicator light illuminates while driving.

The ESC indicator light also illuminates if there is a malfunction in the ABS. The message **Stabilization control (ESC/ABS) Fault! See owner's manual** also appears in the instrument cluster display and a warning tone sounds.

The brake system will still respond even without the assistance of the ABS system. See your authorized Audi dealer as soon as possible to restore full braking performance. For more information regarding the ABS \Rightarrow page 199.

Malfunction in the brake system



If the brake warning light \Rightarrow page 14 and the ABS warning illuminate *together* there may be a malfunction in the ABS, and there may also be a malfunction in the brake system itself \Rightarrow . **The ABS will not work and you will notice a change in braking response and performance.**

In the event of a **malfunction in the brake system** the warning/indicator light **BRAKE** (USA models) /  (Canada models) in the instrument cluster flashes \Rightarrow page 14.



Malfunction in the electronic differential lock (EDL)

The EDL works together with the ABS. The ABS warning light will come on if there is a malfunction in the EDL system \Rightarrow page 199. See your authorized Audi dealer as soon as possible.

WARNING

- If the **ABS** (USA models) /  (Canada models) warning light does not go out, or if it comes on while driving, the ABS system is not working properly. The vehicle can then be stopped only with the standard brakes (without ABS). You will not have the protection ABS provides. Contact your Audi dealer as soon as possible.
- *USA models:* If the **BRAKE** warning light, the  warning light and the **ABS** warning light come on together, the rear

wheels could lock up first under hard braking. Rear wheel lock-up can cause loss of vehicle control and an accident. Have your vehicle repaired immediately by your authorized Audi dealer or a qualified workshop. Drive slowly and avoid sudden, hard brake applications.

- *Canada models:* If the brake warning light , the  warning light and the ABS warning light  come on together, the rear wheels could lock up first under hard braking. Rear wheel lock-up can cause loss of vehicle control and an accident. Have your vehicle repaired immediately by your authorized Audi dealer or a qualified workshop. Drive slowly and avoid sudden, hard brake applications.

Worn brake pads

Brake pads!

If the warning light illuminates, immediately contact your authorized Audi dealer or qualified workshop to have all brake pads inspected. On USA models the warning light  comes on together with the warning light **BRAKE**. Both sets of brake pads on an axle must always be replaced at the same time.

WARNING

Driving with bad brakes can cause a collision and serious personal injury.

- If the warning light  and the warning light **BRAKE**¹⁾ with the message **Brake pads!** comes on in the instrument cluster display, immediately contact your authorized Audi dealer or qualified workshop to have all brake pads checked or replaced if necessary.

EPC Electronic power control

Applies to vehicles: with gasoline engine

This warning/indicator light monitors the electronic power control.

The **EPC** warning/indicator light (Electronic Power Control) illuminates when you switch the ignition on as a function check.

Tips

If this warning/indicator light illuminates while you are driving, then there is a malfunction in the engine electronics. Have the malfunction corrected as soon as possible by your authorized Audi dealer or qualified workshop.

Glow plug system

Applies to vehicles: with diesel engine

The control light illuminates when the glow plug system is active.

If the  indicator light illuminates, the glow plug system is active. You should start the engine immediately after the indicator light switches off. The indicator light only illuminates for approximately 1 second if the engine is warm or if the outside temperature is above 46 °F (8 °C).

Tips

- If the glow plug indicator light illuminates while driving, there is an engine control malfunction. The engine should be checked immediately.
- If the indicator light does not illuminate at all when switching the ignition on, there may be a malfunction in the glow plug system. The engine should be checked.

Malfunction Indicator Lamp (MIL)

The Malfunction Indicator Lamp (MIL) is part of the On-Board Diagnostic (OBD II) system. The symbol  lights up when the ignition is ►

1) **BRAKE**: USA models only

switched on and will turn off after the engine has started and has settled at a constant idle speed. This indicates that the MIL is working properly.

The warning light illuminates when there is a malfunction in the engine electronic system. Contact your authorized Audi dealer and have the malfunction corrected.

An improperly closed fuel filler cap may also cause the MIL light to illuminate

⇒ *page 225.*

For more information ⇒ *page 29.*

Diesel particulate filter clogged

Applies to vehicles: with diesel engine and diesel particulate filter

Particulate filter: System fault See owner's manual

When the  symbol illuminates, you can alter your driving style to assist the filter self-cleaning process. Drive for approximately 15 minutes with the selector lever in the S position at a minimum speed of 37 mph (60 km/h) and an engine speed of approximately 2,000 RPM. The temperature increase that will result from this can burn off the soot in the filter. The symbol will switch off when the cleaning is successful. After a successful cleaning, there is no need to bring the car to an authorized dealer or qualified workshop because this is part of normal vehicle operation.

If the symbol  does not switch off, see your authorized dealer or other qualified workshop to have the problem corrected.

For more information on the diesel particulate filter, refer to ⇒ *page 208.*

WARNING

Always adapt your speed to the current weather, road and traffic conditions. You should never disobey traffic laws in order to follow driving recommendations.

Engine speed limitation

Applies to vehicles: with engine speed limitation

Engine speed maximum XXXX RPM

The engine speed is automatically limited to the speed displayed in the driver information system. This protects the engine from overheating.

The engine speed limitation deactivates once the engine is no longer in the critical temperature range and you have released the accelerator pedal once.

If the engine speed limitation was activated by an engine control malfunction, the indicator light **EPC** also turns on. Make sure that the speed does not go above the speed displayed. Drive to your authorized Audi dealer immediately to have the malfunction corrected.

Engine oil sensor

Oil level! Sensor defective

If the symbol illuminates, contact your authorized Audi dealer and have the oil sensor inspected. Until you have this done, check the oil level each time you refuel just to be on the safe side ⇒ *page 236.*

Fuel level indicator

Please refuel

If the indicator light turns on for the first time and the message appears, there are about 4 gallons (15 liters) of fuel left in the tank. Time to refuel ⇒ *page 224.*

Tank system malfunction! Contact dealer

If the indicator light turns on and this message appears, there is a malfunction in the tank system.

Drive to your authorized Audi dealer immediately to have the malfunction corrected.

Windshield washer fluid level

Please refill washer fluid

If the symbol illuminates, add windshield washer fluid to the washer system/headlight washer system* ⇒ page 247.

Windshield wipers

Windshield wiper defective

There is a malfunction with the windshield wipers.

Drive to your authorized Audi dealer immediately to have the malfunction corrected.

Defective light bulb warning

 - If the indicator light turns on, a bulb has failed. The message indicates the location of the bulb.

 - if a fog lamp* has failed, the indicator light turns on to indicate the location on the vehicle.

 - if a rear fog lamp has failed, the indicator light turns on to indicate the location on the vehicle.

Vehicle lights: malfunction

If the message appears, there is a malfunction in the headlights or light switch.

Drive to your authorized Audi dealer immediately to have the malfunction corrected.

WARNING

- Light bulbs are pressurized and could explode while they are being changed causing serious personal injury.
- Work with due care when handling the high-voltage section of gas discharge (xenon) lights. Failure to do so could result in death or serious injury.

Tips

Have the bulb replaced or the connection repaired by your authorized Audi Service department.

Headlight range control

Headlight range control: defective!

If the symbol illuminates, the headlight range control is no longer working properly. Have the system checked and repaired at your Audi dealer.

Adaptive Light

Applies to vehicles: with Adaptive Light

Audi adaptive light: system fault

If the indicator light turns on and this message appears, there is a malfunction in the adaptive light system. The headlights still function.

Go to an authorized dealership to have the headlights or the control unit for the Adaptive Light repaired.

Light/rain sensor

Automatic headlights/automatic wipers: system fault

If the indicator light turns on and this message appears, the light/rain sensor is not functioning correctly.

For safety reasons the low beams are turned on permanently with the switch in **AUTO**. However, you can continue to turn the lights on and off using the light switch. You can still control all functions that are independent of the rain sensor through the windshield wiper lever.

Contact your authorized Audi dealer as soon as possible to have the problem corrected.

Dynamic steering

Steering: system fault. you can continue driving

If the indicator light turns on and the message appears, the steering may be more difficult to move or more sensitive than usual. The steering wheel may also be at an angle when driving straight.

Drive slowly to your authorized Audi dealer or qualified workshop to have the malfunction corrected.

Dynamic steering: initializing

If this driver message appears and the indicator light is flashing on the instrument panel, dynamic steering is being reinitialized. Once you start the engine after this is finished, the steering wheel will be easy to move. Re-initialization might be necessary if the steering wheel was moved hard to the left and right while the vehicle was not moving. The display goes out as soon as initialization is complete.

WARNING

Have the dynamic steering system malfunction repaired as soon as possible by an authorized Audi dealer or any qualified workshop - risk of accident!

Tips

- The dynamic steering stability systems are not available in the event of a system malfunction.
- For additional information on dynamic steering, refer to [⇒ page 110](#).

Sport differential

Sport differential: system fault

There is a malfunction with the sport differential.

Drive to your authorized Audi dealer immediately to have the malfunction corrected.

Sport differential: overheating

The transmission temperature has increased significantly due to the sporty driving manner. Drive in a less sporty manner until the temperature returns to the normal range and the indicator light switches of.



WARNING

Contact your authorized Audi dealer or a qualified workshop if the sport differential is faulty or malfunctioning. The repair

must be performed by trained personnel using the correct oil in order to ensure safety.

Turn signals

The indicator light blinks when you use either turn signal.

Whenever you use the left  or the right  turn signal, the indicator light blinks. When you use the emergency flashers, both indicator lights flash.

If one of the turn signal light bulbs burn out, the turn signal will blink twice as fast as normal. Carefully drive to your authorized Audi dealer immediately to have the malfunction corrected. The indicator light does not indicate a malfunction if a turn signal on the trailer or on the vehicle fails in trailer towing mode.

Tips

For more information on the turn signals, refer to [⇒ page 48](#).

Driver information display

Overview



Fig. 4 Driver information system in the instrument cluster



Fig. 5 Display: example of the information line

The driver information system contains information (B) that is displayed on tabs (A) ⇒ fig. 4. The following content is possible depending on vehicle equipment:

(A) Tab	(B) Content
1	Vehicle functions:
	On-board computer ⇒ page 25
	Digital speedometer
	Cruise control* ⇒ page 91
	Adaptive cruise control and braking guard* ⇒ page 94
	Audi lane assist* ⇒ page 103
	Display darkened
2	Indicator lights and messages
	Warning when a door, the hood or the rear lid is not closed ⇒ page 29
	Service interval display ⇒ page 28
	Speed warning system ⇒ page 91

(A) Tab	(B) Content
3	Night vision assistant* ⇒ page 113
4	Audio/video
5	Telephone*
6	Navigation*

The second and third tabs are only visible if at least one indicator light or message is shown or if that system is switched on.

The status line (C) is located in the bottom part of the display ⇒ fig. 4. It displays the exterior temperature, time, selector lever position, trip odometer and odometer.

For some vehicle functions, you can access the trip information from the temporary memory ⇒ page 25 in the line (1) ⇒ fig. 5.

! WARNING

- Never rely exclusively on the outside temperature display to determine if a road surface is icy or not. Keep in mind that road surfaces, especially bridges and overpasses, could be ice covered and slippery even at an outside temperature above 41 °F (+5 °C).
- Always remember, even if the “snowflake” symbol (ice warning) does not appear in the display, black ice could be on the road.
- Always reduce your speed and drive with special care in cold weather conditions when the chance of encountering icy road surfaces increases.

i Tips

- At temperatures below 14 °F (+ 5 °C) a snowflake symbol appears ahead of the temperature display. It is intended to remind the driver to pay special attention to **ice on the road** ⇒ !. If the vehicle is stationary, or if you are driving at a very low speed, the temperature shown in the display might be slightly higher than the actual outside temperature. This is

caused by the heat being radiated from the engine.

- You can select the units used for temperature, speed and other measurements in the MMI.
- For information on the audio/video and navigation* functions, refer to the separate MMI owner's manual.

Operation

The driver information system is operated using the buttons on the multifunction steering wheel.



Fig. 6 Multifunction steering wheel: operating the driver information system



Fig. 7 Driver information system: opening the vehicle functions menu

Operating concept

- ▶ Switch the ignition on.
- ▶ To switch between the tabs, press the rocker switch (A) to the left or right ⇒ fig. 6.
- ▶ To access additional information below or above, rotate the thumbwheel (B) down or up.
- ▶ To confirm a selection, press the thumbwheel (B).

Accessing Vehicle functions

- ▶ Select the first tab with the rocker switch (A).
- ▶ Press the button . The **Vehicle functions** menu appears ⇒ fig. 7.
- ▶ To select a menu item, turn and press the thumbwheel (B).

Resetting values to zero

- ▶ Select the **on-board computer/ Efficiency program** menu item in the **Vehicle functions** menu.
- ▶ You can now select between the long-term memory and short-term memory.
- ▶ To reset the values in a memory, press and hold the thumbwheel (B) for one second.

The last function selected displays when you switch the ignition on.

On-board computer

You can call up the following information in the on-board computer:

- Date
- Driving time (h) from the short-term memory
- Average consumption in MPG (l/100 km) from the short-term memory
- Average speed in mph (km/h) from the short-term memory
- Distance driven in miles (km) from the short-term memory
- Current fuel consumption in MPG (l/100 km)
- Short-term memory overview
- Long-term memory overview

The short-term memory collects driving information from the time the ignition is switched on until it is switched off. If you continue driving within two hours after switching the ignition off, the new values are included when calculating the current trip information.

Unlike the short-term memory, the long-term memory is not erased automatically. You can select the time period for evaluating trip information yourself. ▶

For some vehicle functions, you can access the trip information from the temporary memory in the line ① ⇒ page 24, fig. 5.

The current fuel consumption can be displayed using a bar ⇒ page 27, fig. 10. The average consumption (mpg) stored in the short-term memory is also displayed. Electrical energy can be stored in the battery when the vehicle is coasting or driving downhill (recuperation). The bar will move toward .

Efficiency program*

The efficiency program can help you to use less fuel. It evaluates driving information in reference to fuel consumption and shows other equipment influencing consumption as well as shift recommendations. ⇒ page 26. Fuel economy messages ⇒ page 26 provide tips for efficient driving. The efficiency program uses distance and consumption data from trip computer 1.

To display the efficiency program, call up **Vehicle functions** and select the menu option **Efficiency program**. If the data are deleted in the efficiency program, those values are also reset in trip computer.

i Tips

- All stored values will be lost if the vehicle battery is disconnected.
- Fuel consumptions (average and current), range and speed are displayed in metric units on Canadian models.

Other equipment

Applies to vehicles: with efficiency program

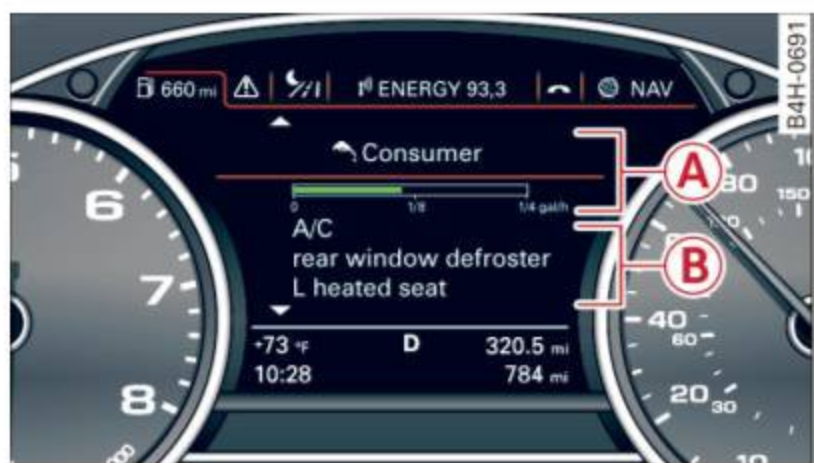

Fig. 8 Trip computer: other equipment

Requirement: The efficiency program must be displayed ⇒ page 26.

- ▶ Turn the thumbwheel until the other equipment appears in the display.

Other equipment that is currently affecting fuel consumption is listed in the efficiency program. The display shows up to three other items of equipment ②. The equipment using the most fuel is listed first. If more than three items using fuel are switched on, the equipment that is currently using the most fuel is displayed.

A scale ① also shows the current total consumption of all other equipment.

Fuel economy messages

Applies to vehicles: with efficiency program

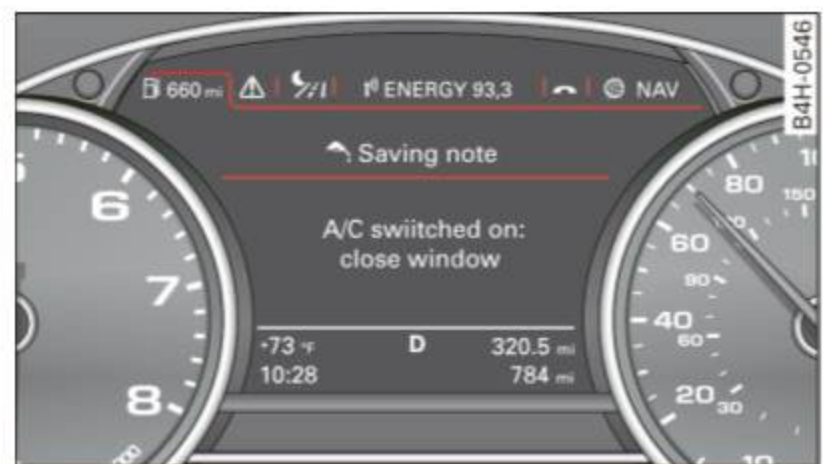

Fig. 9 Display: example of a fuel economy message

Fuel economy messages are displayed when fuel consumption is increased by certain conditions. If you follow these fuel economy messages, you can reduce your vehicle's consumption of fuel. The messages appear automatically and are only displayed in the efficiency program. The fuel economy messages turn off automatically after a certain period of time.

- ▶ To turn an economy message off immediately after it appears, press any button on the multifunction steering wheel.

i Tips

- Once you have turned a fuel economy message off, it will only appear again after you turn the ignition on again.

- The fuel economy messages are not displayed in every instance, but rather in intervals over a period of time.

Cylinder on demand System

Applies to vehicles: with 4.0 TFSI engine



Fig. 10 Instrument cluster: fuel consumption

To save fuel, the engine automatically turns four cylinders on or off, depending on the amount of power needed. This action is not felt by the passengers.

Displaying cylinder mode

Requirement: the on-board computer is displayed ⇒ page 25.

- ▶ Turn the thumbwheel until the current fuel consumption display is shown in the instrument cluster. If the green bar is displayed, you are driving in 4-cylinder mode.

Basic requirements for 4-cylinder mode

4-cylinder drive mode is used automatically if certain basic requirements are fulfilled. These include:

- A low power output requirement.
- Driving in third gear or higher.
- Engine speed between 960 and 3,500 RPM.
- A warm engine.

Odometer



Fig. 11 Instrument cluster Odometer and reset button

The odometer shows you how many miles (kilometers) you have driven. You can switch the display from miles to kilometers and vice versa via the MMI.

Upper odometer

The trip odometer shows the distance driven since it was last reset. It can be used to measure short distances. The last digit indicates 1/10 of a mile (100 meters).

You can reset the trip odometer to zero by pressing the Reset button .

Lower odometer

The lower odometer shows the total number of miles (kilometers) driven.

Malfunction message

If there is a malfunction in the instrument cluster, **DEF** will appear in the trip odometer display area. Contact your authorized Audi dealer to have the problem corrected.

Time and date display



Fig. 12 Center console: analog clock

The date and time are shown in the instrument cluster display ⇒ *page 24, fig. 4*. There is also an analog clock in the center console ⇒ *fig. 12*.

When you open the driver's door, the date and time appear in the instrument cluster display for 30 seconds. When the ignition is switched on, the time is always displayed in the status line Ⓢ regardless of the current display.

You can set the time on both clocks and the date display in the MMI. Refer to the MMI owner's manual for instructions.

Service interval display

The service interval display reminds you when your next service is due.



Fig. 13 Instrument cluster: Service interval display

The schedule for the next oil change or inspection is calculated automatically and displayed accordingly. The display works in two stages:

Service reminder

30 days before the next service is due, a service reminder appears in the display when you switch the ignition on ⇒ *fig. 13*.

After about 5 seconds the display switches back to normal. The distance and time remaining are updated each time the ignition is switched on until the date due for service is reached.

Service due

When the due date for service is reached, the message **Service due!** appears in the instrument cluster immediately after you switch the ignition on. Additionally, a warning tone

sounds. After about 5 seconds the display switches back to normal.

Calling up the service schedules

If or when an oil change or inspection is due, can be shown in the MMI display by selecting the service interval display in the car menu. Select the **CAR** function button > **Car systems** control button > **Servicing & checks** > **Service interval** displays.

Resetting the service interval display

Your authorized Audi dealer will reset the corresponding service schedule after performing the appropriate service on your vehicle. You also have the possibility to reset the oil change schedule after having performed an oil change according to Audi specifications. Select the **CAR** function button > **Car systems** control button > **Servicing & checks** > **Service Intervals** > **Reset oil change interval**.

! Note

If you disconnect the battery terminals, no calculations can be made for the service interval display during this time and no service reminder will appear. Remember that observing the proper service intervals is vitally important to extending the life of your vehicle, particularly the engine, and maintaining its value. Even if the mileage driven is low, the maximum period of one year from one service to the next must not be exceeded.

i Tips

- Do not reset the display between oil changes, otherwise the display will be incorrect.
- The information in the Service Reminder remains stored even when the vehicle battery is disconnected.

Open door/hood/rear lid warning



Fig. 14 Display: doors and rear lid open

With the ignition switched on, the warning illuminates when at least *one* door or the hood or the rear lid is not closed. The symbol also shows you *which* door(s) or lid is not closed.

In the illustration ⇒ *fig. 14* it is the driver's door and the left rear door.

On-Board Diagnostic system (OBD)

Malfunction Indicator Lamp (MIL)

The Malfunction Indicator Lamp (MIL)  in the instrument cluster is part of the On-Board Diagnostic (OBD II) system.

The warning/indicator light illuminates when the ignition is switched on and goes out after the engine starts and the idle has stabilized. This indicates that the MIL is working properly.

If the light does not go out after the engine is started, or illuminates while you are driving, a malfunction may exist in the engine system. If the light illuminates, the catalytic converter could be damaged.

Continue driving **with reduced power** (avoiding sustained high speeds and/or rapid accelerations) and have the condition corrected. Contact your authorized Audi dealer.

If the light illuminates, the electronic speed limiter may also be malfunctioning. For more information ⇒ *page 30, Electronic speed limiter*.

An improperly closed fuel filler cap may also cause the MIL light to illuminate ⇒ *page 225*.

On-Board Diagnostics

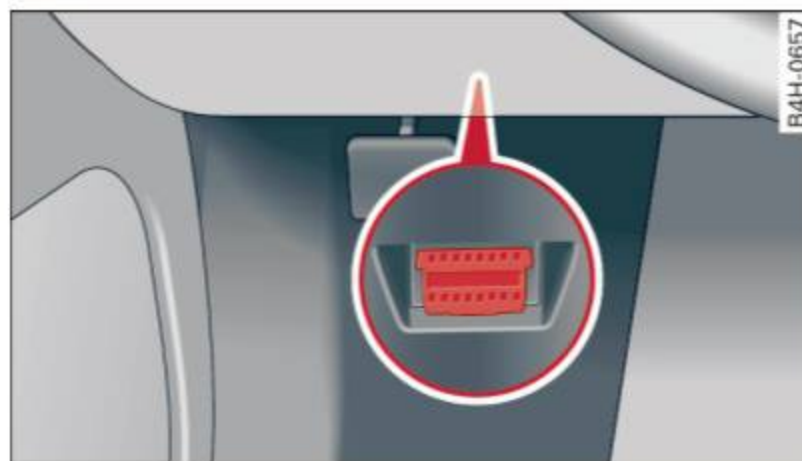

Fig. 15 Location of Data Link Connector (DLC)

On-Board Diagnostics monitors the components of your emission control system. Each monitored component in your engine system has been assigned a code. In case of a malfunction, the component will be identified and the fault stored as a code in the control module memory.

The MIL light may also illuminate if there is a leak in the on-board fuel vapor recovery system. If the light illuminates after a refueling, stop the vehicle and make sure the fuel filler cap is properly closed ⇒ *page 225*.

In order to make an accurate diagnosis, the stored data can only be displayed using special diagnostic equipment (generic scan tool for OBD).

In order to connect the special diagnostic equipment, push the plug into the Data Link Connector (DLC). The DLC is located to the right of the hood release ⇒ *fig. 15*.

Your authorized Audi dealer or a qualified service station can interpret the code and perform the necessary repair.

WARNING

Do not use the diagnostic connector for personal use. Incorrect usage can cause malfunctions, which can increase the risk of a collision!

Electronic speed limiter

Your vehicle may be factory equipped with tires that are rated for a maximum speed of 130 mph (210 km/h). This is less than the maximum speed of your vehicle. To reduce the risk of sudden tire failure and loss of control if the vehicle is operated at excessive speeds, your vehicle also has an electronic speed limiter. The electronic speed limiter prevents your vehicle from going faster than the tire speed rating. For more information ⇒ *page 259*.

If the engine control unit receives faulty vehicle road speed signals, the Malfunction Indicator Lamp (MIL)  will illuminate. If this occurs, contact the nearest authorized Audi dealer for assistance.

S8

Your vehicle's top speed is electronically limited to 155 mph (250 km/h).

If the engine control unit receives faulty vehicle road speed signals, the Malfunction Indicator Lamp (MIL)  will illuminate. If this occurs, contact the nearest authorized Audi dealer for assistance.



WARNING

Always observe the posted speed limits and adjust your speed to suit prevailing road, traffic and weather conditions. Never drive your vehicle faster than the maximum speed rating of the tires installed.

Opening and closing

Keys

Key set



Fig. 16 Key set

A Remote control key with mechanical key

You can centrally lock and unlock your vehicle and start the engine with the master key with remote control. A mechanical key is integrated in the remote control key ⇒ *page 32*.

B Emergency key

The emergency key is not intended for constant use. It should only be used in an emergency. Keep it in a safe place and do not carry it on your key ring.

Key replacement

If you lose a key, contact your authorized Audi dealer immediately to have the *lost* key disabled. Be sure to bring all your keys with you.

Personal comfort settings

If two people use one vehicle, it is recommended that each person always uses “their own” master key. When the ignition is switched off or when the vehicle is locked, personal convenience settings for the following systems are stored and assigned to the remote master key.

- Automatic climate control
- Central locking system
- Rear window sun blind
- Ambient lighting
- Seat memory
- Parking system*

- Adaptive cruise control*
- Audi lane assist*
- Audi side assist*
- Audi drive select
- Night vision assistant*
- Heated steering wheel*

The stored settings are automatically recalled when you unlock the vehicle, when you open the doors or when you switch the ignition on.

! WARNING

- Do not leave your vehicle unattended. Always take your ignition key with you and lock your vehicle. Entry by unauthorized persons could endanger you or result in theft or damage the vehicle.
- Do not leave children unattended in the vehicle, especially with access to vehicle keys. Unguarded access to the keys provides children the opportunity to start the engine and/or activate vehicle systems such as the power windows, etc. Unsupervised operation of any vehicle system by children can result in serious injury.

i Tips

- The operation of the remote control key can be temporarily disrupted by interference from transmitters in the vicinity of the vehicle working in the same frequency range (e.g. a cell phone, radio equipment).
- For security reasons, replacement keys are only available from Audi dealers.
- For Declaration of Compliance to United States FCC and Industry Canada regulations ⇒ *page 295*.

Removing the mechanical key

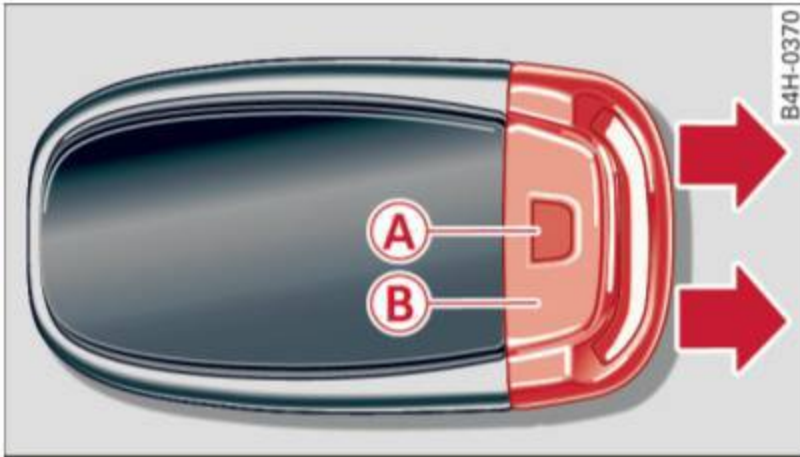

Fig. 17 Remote control master key: removing the mechanical key

- ▶ Press the release button **(A)** ⇒ *fig. 17*.
- ▶ Pull the mechanical key **(B)** out of the master key.

Using the mechanical key, you can:

- lock and unlock* the storage compartment on the passenger's side ⇒ *page 75*.
- lock and unlock the vehicle manually ⇒ *page 36*.
- lock the front and rear passenger doors mechanically ⇒ *page 37*.
- unlock the luggage compartment lid manually ⇒ *page 40*.

Check light and battery in the master key

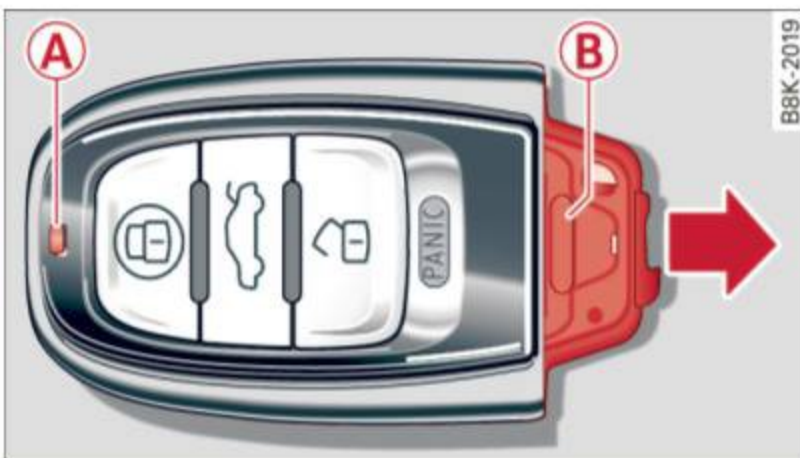



Fig. 18 Remote master key: Removing the battery holder

Check light in the master key

The check light **(A)** ⇒ *fig. 18* in the master key provides information about different conditions.

- ▶ The check light turns on briefly once when a button is pressed, and during an “inquiry” by the convenience key system.

- ▶ If the check light does not come on, the battery is dead and has to be replaced. In addition, when the battery is dead the  indicator light appears in the instrument cluster display as well as the message **Please change the key battery**.

Master key battery replacement

- ▶ Remove the mechanical key ⇒ *page 32*.
- ▶ Press the release button **(B)** ⇒ *fig. 18* on the battery holder and at the same time pull the battery holder out of the master key in the direction of the arrow.
- ▶ Install the new battery CR 2032 with the “+” sign facing down.
- ▶ Push the battery holder carefully into the master key.
- ▶ Install the mechanical key.



For the sake of the environment

Dispose of dead batteries properly so as not to pollute the environment.



Tips

The replacement battery must be the same specification as the original.

Electronic immobilizer

The immobilizer helps to prevent unauthorized use of your vehicle.

A computer chip inside your key automatically deactivates the electronic immobilizer when the key is inside the vehicle. When you remove the key from the vehicle, the electronic immobilizer is automatically activated once again.



WARNING

Always take the key with you when you leave the vehicle. The key can disarm the electronic engine immobilizer and permit an unauthorized person to start the engine and enable operation of the vehicle systems such as power window or power sunroof leading to serious personal injury.

Tips

- The vehicle cannot be started if an unauthorized key is used. The vehicle may not start if another radio device such as a key for another vehicle or a transponder is located on the key ring.
- For Declaration of Compliance to United States FCC and Industry Canada regulations ⇒ *page 295*.

Power locking system

General description

The power locking system locks or unlocks all doors and the luggage compartment lid simultaneously.

You can lock and unlock the vehicle centrally. You have the following choices:

- Remote master key ⇒ *page 35*,
- Door handles with convenience key* ⇒ *page 35*,
- Lock cylinder at the driver's door ⇒ *page 36*, or
- Power locking switch inside ⇒ *page 36*.

Selective unlocking

When you lock the vehicle, the power locking system will lock the doors and the luggage compartment lid. When unlocking, you can set in the MMI whether only the driver's door or the entire vehicle should be unlocked ⇒ *page 34*.

Automatic locking

The automatic locking feature locks all the vehicle doors and the luggage compartment lid when you drive faster than 9 mph (15 km/h).

The car is unlocked again, when the opening function in the power locking system switch or at one of the door levers is actuated. The Auto Lock function can be turned on and off in the MMI ⇒ *page 34*.

Anti-theft alarm warning system

If the anti-theft alarm warning system detects a break-in into the vehicle, acoustic and visual warning signals are triggered.

The anti-theft warning system is activated automatically when you lock the vehicle. It is deactivated when unlocking using the remote key, with the mechanical key, and when you switch the ignition on.

The alarm also turns off when the alarm cycle has expired.

Turn signals

When you unlock the vehicle, the turn signals flash twice. When you lock the vehicle once, the turn signals flash once. If they do not flash, one of the doors, the luggage compartment lid or the hood is not locked.

Unintentionally locking yourself out

In the following cases there are safeguards to prevent you locking your remote master key in the vehicle:

- The vehicle does not lock with the central locking switch ⇒ *page 36* if the driver's door is open.
- On vehicles with convenience key*, if the most recently used master key is in the luggage compartment, the luggage compartment lid is automatically unlocked again after it is closed.

Do not lock your vehicle with the **remote master key** or **convenience key*** until all doors and the luggage compartment lid are closed. In this way you avoid locking yourself out accidentally.

Power side door closer*

The vehicle doors are equipped with a power side door closer. When closing a door, you only have to let it fall lightly into the latch. The door will then automatically close by itself ⇒ .

WARNING

- When you lock your vehicle from outside, nobody - especially children - should remain inside the vehicle. Remember, when you lock the vehicle from the outside the windows cannot be opened from the inside.
- When you leave the vehicle, always take the ignition key with you. This will prevent passengers (children, for example) from accidentally being locked in the vehicle should they accidentally press the power locking switch in the doors.
- Do not leave children inside the vehicle unsupervised. In an emergency it would be impossible to open the doors from the outside without the key.
- Applies to vehicles with power side door closer*:
 - When closing a door, make sure nothing can interfere with the door. This could cause serious personal injury.
 - You can stop the door from closing at any time by pulling on the inside or outside door handle.

Tips

- In the event of a crash with airbag deployment all locked doors will be automatically unlocked to give access to the vehicle occupants from the outside.
- If the power locking system should malfunction, you can lock the driver's door using the mechanical key ⇒ *page 37*.
- If the power locking system should fail, you can still open the fuel tank flap in an emergency ⇒ *page 227*.
- You are well advised not to keep valuables inside an unattended vehicle, visible or not. Even a properly locked vehicle cannot provide the security of a safe.
- If the LED in the upper edge of the driver's door panel comes on for about 30 seconds after the vehicle is locked, there is a malfunction in the power locking or the anti-theft warning system. Have the malfunction corrected by an authorized

Audi dealership or qualified repair facility.

Setting power locking

The driver can determine the functions for power locking in the MMI.



- ▶ Select:  function button > **Car systems** control button > **Vehicle settings** > (**Central locking**).

Lock when driving - If you select **On**, the vehicle locks automatically when driving. All of the doors and luggage compartment lid lock.

Central locking

Unlock doors - You can decide if **All** doors or only the **Driver** should unlock. The luggage compartment lid also unlocks when **All** is selected. If you select **Driver** in a vehicle with a convenience key*, only the door whose handle you pull will unlock.

If you select **Driver**, all the doors and luggage compartment lid will unlock if you press the  button on the remote control master key twice.

Lock exterior trunk handle - If you select **On**, the luggage compartment lid handle is locked. In this case the luggage compartment lid can be opened with the button  on the master key or with the  button* in the driver's door. In vehicles with a convenience key*, you can still open the luggage compartment lid using the handle if an authorized master key is near the proximity sensor.

Fold mirrors* - If you select **On**, the exterior rearview mirrors fold in automatically when you press the  button on the remote control master key or touch the sensor* in the handle.





Tone when locking - When you select **On**, a confirmation tone sounds when you lock the vehicle.

Locking and unlocking the vehicle with the remote control



Fig. 19 Remote control: function buttons

Either the driver's door only or the entire vehicle will unlock when the unlock button  is pressed once, depending on the settings in the MMI ⇒ page 34.

- ▶ Press button  to unlock the vehicle ⇒ fig. 19.
- ▶ Press button  to lock the vehicle ⇒  in *General description on page 34*.
- ▶ Press button  briefly to unlock the luggage compartment lid.
- ▶ Push the red **PANIC** button to activate the panic function. The horn sounds and the turn signals flash. Push the red **PANIC** button again to deactivate the panic function.

If the vehicle is unlocked and no door, the luggage compartment lid or the hood is opened within 60 seconds, the vehicle locks itself again automatically. This feature prevents the vehicle from being accidentally left unlocked over a long period of time.

It depends on the settings in the MMI whether the entire vehicle is unlocked or only certain doors ⇒ page 34.

WARNING

Read and follow all WARNINGS ⇒  in *General description on page 34*.

Tips

- In order to make sure the locking function is working, you should always keep your eye on the vehicle to make sure it is properly locked.

- Do not use the remote control if you are inside the car, otherwise you may unintentionally lock the vehicle, and then you would set off the anti-theft alarm when you try to start the engine or open a door. In case this happens anyhow, push the unlock button .
- The vehicle can only be locked when the selector lever is in the P position.
- Use the panic function only if you are in an emergency situation.

Locking and unlocking with convenience key

Applies to vehicles: with convenience key

The doors and the luggage compartment lid can be unlocked and locked without operating the master key.

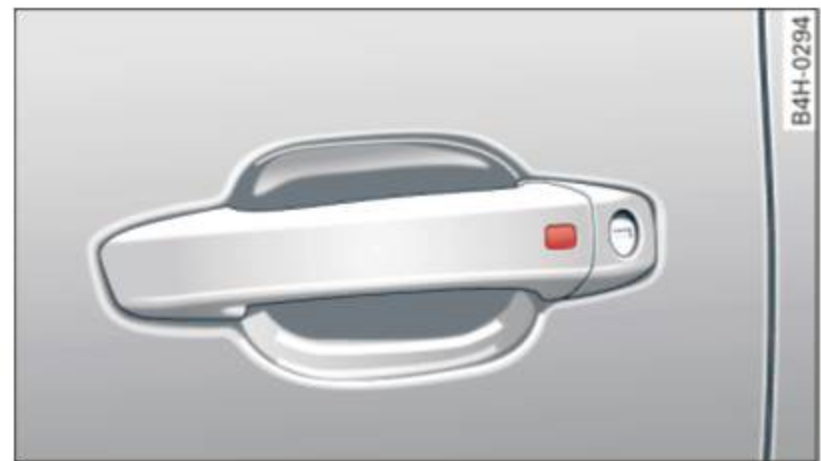

Fig. 20 Convenience key: Locking the vehicle

Unlocking vehicle

- ▶ Take hold of the door handle. The door is unlocked automatically.
- ▶ Pull the handle to open the door.

Locking vehicle

- ▶ Select the P selector lever position. Otherwise the vehicle cannot be locked.
- ▶ To lock the vehicle, close the door and touch the sensor in the door handle **once** ⇒ fig. 20. Do not reach inside the door handle.

The vehicle can be locked and unlocked at any door. The master key must be within a range of about 1.5 m from the appropriate door or the luggage compartment lid. It makes no difference whether the master key is in your jacket pocket or in your brief case. ▶

It is not possible to re-open the door for a brief period directly after closing it. This allows you to ensure that the doors are properly locked.

It depends on the settings in the MMI whether the entire vehicle is unlocked or one of the doors ⇒ *page 34*.

WARNING

Read and follow all WARNINGS ⇒  in *General description on page 34*.

Tips

If your vehicle has been standing for an extended period, please note the following:

- The proximity sensors are deactivated after a few days to save power. You then have to pull on the door handle once to unlock the vehicle and a second time to open the vehicle.
- To prevent the battery from draining and to preserve your vehicle's ability to start for as long as possible, the energy management system gradually switches off unnecessary convenience functions. It is possible that you will not be able to unlock your vehicle using these convenience functions.
- For Declaration of Compliance to United States FCC and Industry Canada regulations ⇒ *page 295*.

Operating locks with the key

In the event of a failure of the power locking system, the driver's door can be locked and unlocked at the lock cylinder.

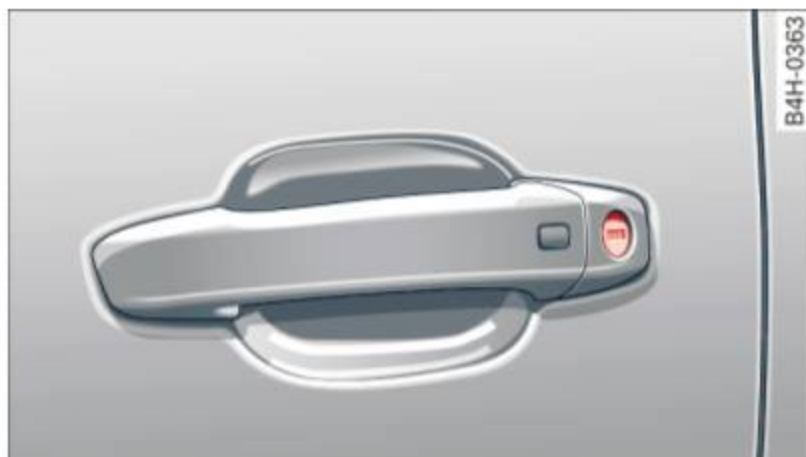



Fig. 21 Key turns for opening and closing.

- ▶ Remove the mechanical key ⇒ *page 32*.
- ▶ Turn the key to the left to unlock the driver's door.
- ▶ Turn the key to the right to lock the driver's door ⇒ .

WARNING

Read and follow all WARNINGS ⇒  in *General description on page 34*.



Locking and unlocking the vehicle from inside



Fig. 22 Driver's door: power locking switch



Fig. 23 Rear power locking switch

- ▶ Press the button  to lock the vehicle ⇒ .
- ▶ Press the button  to unlock the vehicle ⇒ *fig. 22*, ⇒ *fig. 23*.

If you lock the vehicle using the power locking switch, please note the following:

- You cannot open the doors or the luggage compartment lid from the *outside* (increased security, for example when you are stopped at a red light).
- The diodes in the power locking switches illuminate when all the doors are closed and locked.

- Front doors: you can unlock and open the doors from the inside by pulling on the door handle.
- Rear doors: pull the door handle *once* to release the lock. Pull the handle *again* to open the door.
- If you have a crash and the airbag is activated, the doors automatically unlock.

WARNING

- The power locking switch works with the ignition off and automatically locks the entire vehicle when it is actuated.
- On a vehicle locked from the outside the power locking system switch is inoperative.
- Locked doors make it more difficult for emergency workers to get into the vehicle, which puts lives at risk. Do not leave anyone behind in the vehicle, especially children.

Tips

Your vehicle is locked automatically at a speed of 9 mph (15 km/h) ⇒ *page 33*. You can unlock the vehicle again using the opening function in the power locking system switch.

Emergency locking

Each door must be locked separately if the power locking system fails.



Fig. 24 Door: Emergency locking

An emergency lock is located on the front end of the passenger's door and the rear doors (only visible when door is open).

- ▶ Remove the mechanical key ⇒ *page 32*.

- ▶ Pull the cover cap out of the opening ⇒ *fig. 24*.
- ▶ Insert the key in the inside slot and turn it all the way to the right (right door) or left (left door).

Once the door has been closed, it can no longer be opened from the outside. The door can be opened from the inside by pulling the door handle. If the child safety lock in a rear door is activated, you must first pull the door handle on the inside. Then you can open the door from the outside.

Luggage compartment lid

Opening/closing the luggage compartment lid





Fig. 25 Driver's door: remote luggage compartment lid release



Fig. 26 Position of lock and handle in the luggage compartment lid

Opening the luggage compartment lid

- ▶ Press the  button on the remote control master key briefly. The luggage compartment lid will unlock.
- ▶ To open the luggage compartment lid, press and hold the  button on the remote control master key for at least one second. Or ▶

- ▶ Pull the button  in the driver's door ⇒ *fig. 25* briefly. Or
- ▶ Press the handle in the luggage compartment lid ⇒ *fig. 26*.

Closing the luggage compartment lid

- ▶ Pull the luggage compartment lid down and allow it to drop gently. The lid is then closed automatically ⇒ .

The settings in the MMI determine if the luggage compartment lid can be opened using the handle ⇒ *page 34*.

WARNING

- After closing the luggage compartment lid, always pull up on it to make sure that it is properly closed. Otherwise it could open suddenly when the vehicle is moving.
- To help prevent poisonous exhaust gas from being drawn into the vehicle, always keep the luggage compartment lid closed while driving. Never transport objects larger than those which fit completely into the luggage area, because then the luggage compartment lid cannot be fully closed.
- Never leave your vehicle unattended especially with the luggage compartment lid left open. A child could crawl into the car through the luggage compartment and pull the lid shut, becoming trapped and unable to get out. To reduce the risk of personal injury, never let children play in or around your vehicle. Always keep the luggage compartment lid as well as the vehicle doors closed when not in use.

Tips

When the vehicle is locked, the luggage compartment lid can be unlocked separately by pressing the button  on the master key. When the luggage compartment lid is closed again, it locks automatically.

Power opening/closing luggage compartment lid



Applies to vehicles: with power opening/closing luggage compartment lid

The luggage compartment lid can open and close electrically.







Fig. 27 Locking switch in luggage compartment lid

Opening the luggage compartment lid

- ▶ Press the  button on the remote control master key briefly. The luggage compartment lid will unlock.
- ▶ To open the luggage compartment lid, press and hold the  button on the remote control master key for at least one second. Or
- ▶ Pull the button  in the driver's door ⇒ *page 37, fig. 26* briefly. Or
- ▶ Press the handle in the luggage compartment lid ⇒ *page 37, fig. 26*.



Closing the luggage compartment lid

- ▶ Press the  button in the luggage compartment lid ⇒ *fig. 27*. The luggage compartment lid moves to the closed position by itself and soft close locks it automatically ⇒ . Or
- ▶ Switch the ignition on and pull and hold the button  in the driver's door until the luggage compartment lid is closed ⇒ . Or
- ▶ Pull down on the luggage compartment lid lightly using the handle. The closing procedure finishes automatically.

The settings in the MMI determine if the luggage compartment lid can be opened using the handle ⇒ *page 34*.

Opening will be stopped immediately when:



- You press the  button on the remote control master key, or

- You press the  button in the luggage compartment lid, or
- You push the handle in the luggage compartment lid, or
- You pull the  button in the driver's door, or
- When something blocks the luggage compartment lid or makes it difficult for the lid to move.

If you press one of the buttons  now, the luggage compartment lid will either open or close, depending on its angle.

If you pull lightly on its handle, the luggage compartment lid will close.

Closing will be stopped immediately when:

- You press the  button in the luggage compartment lid, or
- You push the handle in the luggage compartment lid, or
- You release the  button on the driver's door, or
- When something blocks the luggage compartment lid or makes it difficult for the lid to move.

If you press one of the buttons  now, the luggage compartment lid will either close or open, depending on its angle.

If you pull lightly on its handle, the luggage compartment lid will close.

You can manually stop the automatic opening/closing of the luggage compartment lid. The automatic closing process begins if you push down on the luggage compartment lid.

WARNING

- After closing the luggage compartment lid, always pull up on it to make sure that it is properly closed. Otherwise it could open suddenly when the vehicle is moving.
- To help prevent poisonous exhaust gas from being drawn into the vehicle, always keep the luggage compartment lid closed while driving. Never transport ob-

jects larger than those which fit completely into the luggage area, because then the luggage compartment lid cannot be fully closed.

- Never leave your vehicle unattended especially with the luggage compartment lid left open. A child could crawl into the car through the luggage compartment and pull the lid shut, becoming trapped and unable to get out. To reduce the risk of personal injury, never let children play in or around your vehicle. Always keep the luggage compartment lid as well as the vehicle doors closed when not in use.
- Never close the luggage compartment lid inattentively or without checking first. Although the closing force of the luggage compartment lid is limited, you can still seriously injure yourself or others.
- Always ensure that no one is within range of the luggage compartment lid when it is moving, in particular close to the hinges and the upper and lower edges - fingers or hands can be pinched.
- Never try to interfere with the luggage compartment lid or help it when it is being opened or closed automatically.

Tips

- If there is a mechanical problem with automatic closing for the luggage compartment lid or there is an obstruction, it opens again immediately. Check to see why the luggage compartment lid could not be closed before attempting to close it again.
- The following applies to vehicles equipped with the Convenience key* feature: if the remote control key is left in the luggage compartment, luggage compartment will automatically unlock itself after you lock the vehicle. This prevents you from unintentionally locking your key in the luggage compartment.
- When the vehicle is locked, the luggage compartment lid can be unlocked separately by pressing the button  on the

master key. When the luggage compartment lid is closed again, it locks automatically.

- If the vehicle battery charge drops below a certain level, you can still open or close the luggage compartment lid manually, however, you will need to apply more force to close it.

Luggage compartment with movement-activated opening

Applies to the model:

Applies to vehicles: with convenience key and sensor-controlled luggage compartment lid



Fig. 28 Rear of vehicle: foot movement

Requirements: You must be carrying your vehicle key with you. You must be standing at the center behind the luggage compartment lid. The distance to the rear of the vehicle must be at least 8 inches (20 cm). The ignition must be switched off. Make sure you have firm footing.

- ▶ Swing your foot forth and back below the bumper ⇒ *fig. 28*. Do not touch the bumper. Once the system recognizes the movement, the luggage compartment lid will open.

The luggage compartment lid will only open if you make the movement as described. This prevents the luggage compartment lid from opening due to similar movements such as when you walk between the rear of the vehicle and your garage door.

General information

In some situations, the function is limited or temporarily unavailable. This may happen if:

- the luggage compartment lid was just closed.
- you park close to a hedge and the branches move back and forth under the vehicle for a long period of time.
- you clean your vehicle, for example with a pressure washer or in a car wash.
- there is heavy rain.
- the bumper is very dirty, for example after driving on salted roads.
- there is interference to the radio signal from the vehicle key, such as from cell phones or remote controls.

Luggage compartment lid emergency release

If the central locking system fails, the luggage compartment lid can be opened at the lock cylinder.



Fig. 29 Luggage compartment lid: mechanical key in the lock cylinder

- ▶ Remove the mechanical key ⇒ *page 32*.
- ▶ Insert the key in the lock cylinder as pictured.
- ▶ Turn the key approximately 45° to the right ⇒ *fig. 29*. The luggage compartment lid opens.

In this position the key cannot be pulled out of the lock cylinder.

Child safety lock

Mechanical child safety lock in the rear doors

The child safety lock prevents the rear doors from being opened from the inside.



Fig. 30 Rear doors: child safety lock

The child safety lock is visible only when the door is open.

- ▶ Remove the mechanical key ⇒ page 32.
- ▶ To switch on the child safety lock, turn the key in the direction of the arrow.
- ▶ To switch off the child safety lock, turn the key in the opposite direction to the arrow.

When the child safety locks are activated, the inside door handles do not work and the doors can only be opened from the outside.

Power child safety lock for the rear doors

Applies to vehicles: with power child safety lock in the rear doors





The power child safety lock  prevents the rear doors from being opened from the inside.



Fig. 31 Section from driver's door: controls

- ▶ To activate the child safety lock for the left/right rear door, press the left/right button  in the driver's door ⇒ fig. 31. The light in the button will turn on.
- ▶ To deactivate the child safety lock for the left/right rear door, press the left/right button  in the driver's door. The light in the button turns off.

The following features are switched off:

- The interior door handles in the rear doors,
- The power windows in the rear doors,
- The buttons for the sun shade* in the rear window,
- The buttons for the power sun shades* in the side windows,
- The front passenger power seat adjustment* button (by pressing the right button ).

In order to activate the child safety lock on the left and the right side, press the two safety buttons  in succession.

Power windows

Controls

The driver can control all power windows.

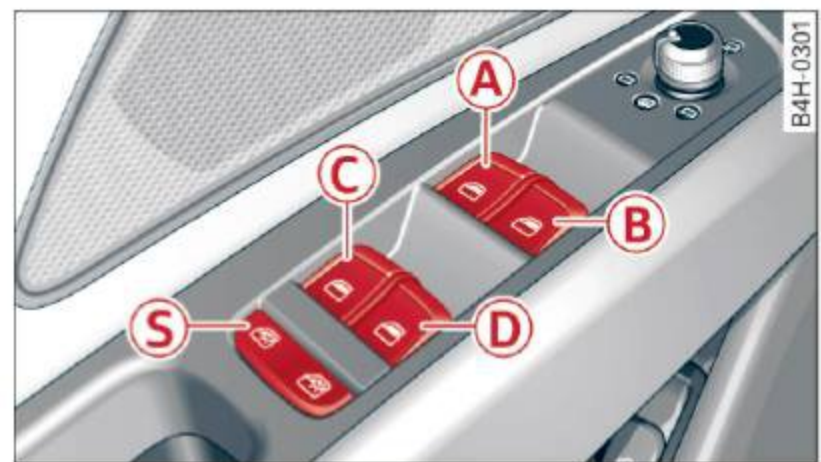

Fig. 32 Section of the driver's door: Controls

All power window switches are provided with a **two-position function**:

Opening the windows

- ▶ Press the switch to the **first stop** and hold it until the window reaches the desired position.
- ▶ Press the switch briefly to the **second stop** to automatically open the window.

Closing the windows

- ▶ Pull the switch to the **first stop** and hold it until the window reaches the desired position.
- ▶ Pull the switch briefly to the **second stop** to automatically close the window.

Power window switches

- (A) Driver's door
- (B) Passenger's door
- (C) Left rear door
- (D) Right rear door
- (S) Safety button (or two safety buttons in vehicles with power child safety locks ⇒ page 41)

Child safety lock

When the safety button (S) ⇒ fig. 32 is pressed, the LED in the button lights up. The following features are switched off:

- The power windows in the rear doors,
- The buttons for the power sun shades* in the side windows,
- The buttons for the power sun shade* in the rear window,
- Front passenger power seat adjustment* button.

! WARNING

- When you leave your vehicle - even if only briefly - always take the ignition key with you. This applies particularly when children remain in the vehicle. Otherwise the children could start the engine or operate electrical equipment (e.g. power windows). The power windows are functional until the driver's door or passenger's door has been opened.
- Be careful when closing the windows. Check to see that no one is in the way, or serious injury could result!
- When locking the vehicle from outside, the vehicle must be unoccupied since the windows can no longer be opened in an emergency.

i Tips

- The driver can lower or raise the power sun shades* in the side windows by using switches (C) and (D).
- After the ignition has been switched off, the windows can still be opened or closed for about 10 minutes. The power windows are not switched off until the driver's door or passenger's door has been opened.

What to do after a malfunction

The one-touch open and close function must be reactivated if the battery has been disconnected.

- ▶ Pull and hold the power window switch until the window is fully closed.
- ▶ Release the switch and then pull it again for at least one second.

Valet parking

The valet parking feature protects the luggage compartment from unauthorized access.





Fig. 33 Valet parking button

With “valet parking” activated, the luggage compartment lid cannot be opened.

- ▶ Remove the mechanical key ⇒ page 32.
- ▶ Open the glove compartment and activate ⇒ fig. 33 the “valet parking” feature by pressing the **VALET** button. The indicator light in the switch illuminates.
- ▶ Close the glove compartment and lock it with the mechanical key.

- ▶ Leave the master key with the service personnel for parking and keep the mechanical key with you.

When the “valet parking” feature is activated:

- the unlocking button for the luggage compartment lid  in the driver's door is inactive
- the button  on the master key is inactive
- the opening handle in the luggage compartment lid is inactive.

The vehicle can be driven and locked and unlocked with the master key. Access to the luggage compartment is blocked.

When the valet parking function is switched on, the message **Valet parking activated** appears in the instrument cluster display when you switch the ignition on.

Sliding/tilting sunroof

Operation

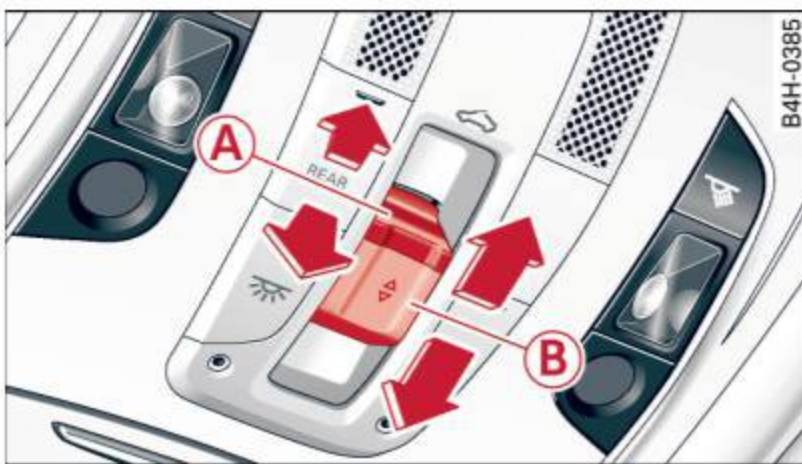



Fig. 34 Section of the headliner: Sliding/tilting sunroof button

A Tilting and sliding

- ▶ To tilt the sunroof completely, press the switch briefly to the second level ⇒ *fig. 34* briefly.
- ▶ To close the sunroof completely, pull the switch briefly to the second level ⇒ .
- ▶ To select an intermediate position, press/pull the switch to the first level until the desired position is reached.

B Opening and closing

- ▶ To open the sunroof completely, slide the button back briefly to the second level.

- ▶ To close the sunroof completely, slide the button forward briefly to the second level ⇒ .
- ▶ To select a partially open position, slide the button forward/back to the first level until the roof reaches the desired position.

A wind deflector integrated into the sliding/tilting sunroof adapts automatically to the speed and sunroof position. This reduces wind noise to a minimum in all sunroof positions.

You can still close or open the sunroof for up to ten minutes after you have switched the ignition off. The switch is deactivated once the driver's or front passenger's door is opened.

Solar protection

The solar protection opens automatically when the sunroof opens.

Vehicles with a glass panel sunroof: the sun shade can be opened and closed by hand when the sunroof is closed.

Vehicles with a solar panel sunroof*: the closed sunshade opens automatically when the sunroof opens.

WARNING

Pay careful attention when closing the sliding/tilting sunroof - otherwise serious injury could result! Always take the key with you when leaving the vehicle.

Note

Always close your sliding/tilting sunroof when leaving your vehicle. Sudden rain can cause damage to the interior equipment of your vehicle, particularly the electronic equipment.

Tips

- Information regarding the solar roof* ⇒ *page 82*.
- The sliding/tilting sunroof will only open at temperatures above -4 °F (-20 °C).

Emergency closing of the sliding/tilting sunroof

If the sunroof detects an object in its path when it is closing, it will open again automatically. In this case, you can close the roof with the power emergency closing function.

- ▶ Within five seconds after the sunroof opens automatically, pull the switch until the roof closes.

Panoramic sunroof

Opening/closing the roof

Applies to vehicles: with panoramic sunroof

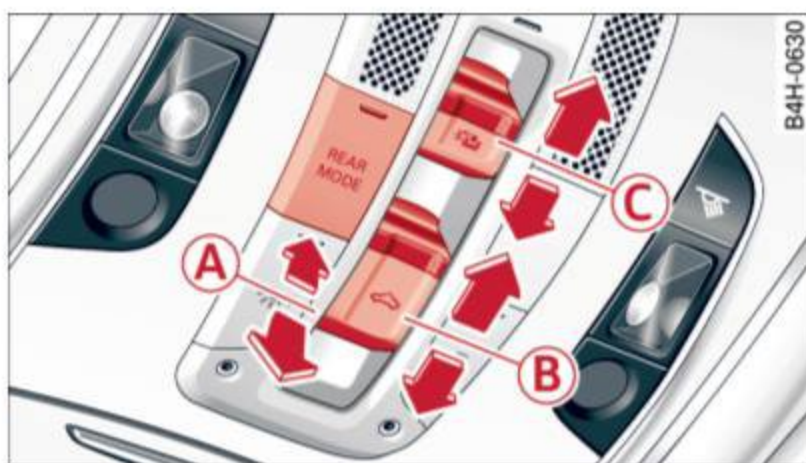

Fig. 35 Section of the front headliner: panoramic sunroof button



Fig. 36 Rear door: panoramic sunroof button

A Tilting the front segment of the roof

- ▶ To tilt the sunroof completely, press the button up briefly to the second level ☰.
- ▶ To close the sunroof completely, pull the button ☰ down briefly to the second level ⇒ ⚠.
- ▶ To select a tilted position, press/pull the button ☰ to the first level until the desired position is reached.

B Sliding the front segment of the roof

- ▶ To open the sunroof completely, slide the button ☰ back to just before the second level ⇒ fig. 35.
- ▶ To close the sunroof completely, slide the button ☰ forward briefly to the second level ⇒ ⚠.
- ▶ To select a partially open position, slide the button ☰ forward/back to the first level until the desired position is reached.

Tilting the rear segment of the roof

The rear segment of the roof can be operated both from the cockpit and from the rear seat.

- ▶ To tilt the sunroof completely, press the button ☰ in the rear door briefly to the second level ⇒ fig. 36.
- ▶ To close the sunroof completely, pull the button ☰ up briefly to the second level ⇒ ⚠.
- ▶ To select a tilted position, press/pull the button ☰ to the first level until the desired position is reached. Or
- ▶ To operate the roof from the cockpit, press the **REAR MODE** button ⇒ fig. 35. You can now open/close the rear segment of the roof using the button ☰ in the headliner. The LED in the front of the headliner turns on when the rear roof segment is tilted.

After the ignition is switched off, you can still operate the panoramic sunroof for about 10 minutes. The switch is deactivated once the driver's or front passenger's door is opened.

⚠ WARNING

Be careful when closing the panoramic sunroof - otherwise serious injury could result! For this reason, always take the ignition key with you when leaving the vehicle.

! Note

Always close your panoramic sunroof when leaving your vehicle. Sudden rain can cause damage to the interior equipment of your vehicle, particularly the electronic equipment.



Tips

- Information regarding convenience opening/closing ⇒ *page 34*.
- The panoramic sunroof will only open at temperatures above -4 °F (-20 °C).
- To prevent both roof segments from colliding with one another, you do not need to
 - tilt the rear roof segment if the front roof segment is already open.
 - close the front roof segment if the rear roof segment is already tilted.





Opening/closing the sun shade

Applies to vehicles: with panoramic sunroof

Front sun shade

- ▶ To open the sun shade completely, slide the button  back to just before the second level ⇒ *page 44, fig. 35*.
- ▶ To close the sun shade completely, slide the button  forward briefly to the second level.
- ▶ To select a partially open position, slide the button  to the first level until the desired position is reached.

Rear sun shade

- ▶ To open the sun shade completely, press the button  in the rear door briefly to the second level ⇒ *page 44, fig. 36*.
- ▶ To close the sun shade completely, pull the button  up to the second level ⇒ .
- ▶ To select a partially open position, press/pull the button  to the first level until the desired position is reached. Or
- ▶ To operate the sun shade from the cockpit, press the **REAR MODE** button ⇒ *page 44, fig. 35*. You can now open/close the rear sun shade using the button  in the headliner.

WARNING

Be careful when closing the panoramic sunroof - otherwise serious injury could result! For this reason, always take the ignition key with you when leaving the vehicle.

Roof segment/sun shade emergency closing

Applies to vehicles: with panoramic sunroof

If the roof segment or sun shade detects an object in its path when it is closing, it will open again automatically. In this case, you can then close it with the power emergency closing function.

- ▶ Within five seconds after the roof segment or sun shade opens automatically, pull the switch until it closes.

Clear vision

Lights

Switching the headlights on and off



Fig. 37 Instrument panel: light switch with all-weather lights*



The headlights only work when the ignition is switched on. While starting the engine or when switching off the ignition, the headlights will go off and only the side marker lights will be on.

If the system is not operating properly, a warning symbol in the driver information display is displayed ⇒ *page 22*.

Light switch

Turn the switch ⇒ *fig. 37* to the corresponding position. When the lights are switched on, the  symbol turns on.

0 - The lights are off or the daytime running lights are on:

- **USA models:** The daytime running lights will come on automatically when the ignition is on and the light switch ⇒ *fig. 37* is in the **0** position or the **AUTO** position (only in daylight conditions). The **Daytime running lights** function can be turned on and off in the MMI ⇒ *page 48*, ⇒ .
- **Canada models:** The daytime running lights will come on automatically when the ignition is on and the light switch ⇒ *fig. 37* is in the **0** position, the  position or the **AUTO** position (only in daylight conditions) ⇒ .



AUTO - Automatic headlights switch on and off depending on brightness, for example in twilight, during rain or in tunnels ⇒ .

 - Side marker lights

 - Low beam headlights

 - Fog lights* (vehicles with Xenon plus headlights*)

 - All-weather lights* (vehicles with LED headlights*) ⇒ *fig. 37*

 - Rear fog lights*. When the rear fog lights are on, the symbol  on the switch will illuminate.

All-weather lights*

In vehicles with all-weather lights, the front lights are adjusted automatically so that you are less likely to see glare from your own headlights, for example when driving on a wet road.

Automatic dynamic headlight range control*

Your vehicle is equipped with a headlight range control system so that the headlights do not blind oncoming traffic if the vehicle load changes. The headlight range also adjusts automatically when braking and accelerating.

Light functions

The following light functions are available depending on vehicle equipment and only function when the light switch is in the **AUTO** position. You can deactivate these functions in the MMI under **Audi adaptive light** ⇒ *page 48*.

Static cornering light* (vehicles with LED headlights or adaptive light) - the cornering light switches on automatically when the steering wheel is turned at a certain angle at speeds up to approximately 44 mph (70 km/h) and when the turn signal is activated at speeds up to approximately 25 mph (40 km/h). The area to the side of the vehicle is illuminated better when turning.

Dynamic curve light* (vehicles with adaptive light) - the curve light only functions at speeds between approximately 6 mph (10 km/h) and 68 mph (110 km/h) and adapts itself to the curves in the road.

Highway light function* (vehicles with LED headlights) - this function adapts the lighting for highway driving based on vehicle speed.

WARNING

- Automatic headlights are only intended to assist the driver. They do not relieve the driver of his responsibility to check the headlights and to turn them on manually according to the current light and visibility conditions. For example, fog cannot be detected by the light sensors. So always switch on the headlights  under these weather conditions and when driving in the dark.
- Crashes can happen when you cannot see the road ahead and when you cannot be seen by other motorists. Always turn on the headlights so that you can see ahead and so that others can see your car from the back.
- Please observe legal regulations when using the lighting systems described.

Note

The rear fog lights should only be turned on in accordance with traffic regulation, as the lights are bright for following traffic.

Tips

- The light sensor* for automatic dynamic headlight range control* is located in the rear view mirror mount. You should therefore not apply any stickers to the windshield in this area in order to prevent malfunctions or failures.
- In the event of a light sensor malfunction, the driver is notified in the instrument cluster display ⇒ page 22.
- You will hear a warning tone if you open the driver door when the exterior lights are switched on.
- In cool or damp weather, the inside of the headlights, turn signals and tail lights can fog over due to the temperature difference between the inside and outside. They will clear shortly after

switching them on. This does not affect the service life of the lighting.



Emergency flasher

The emergency flasher makes other motorists aware that you or your vehicle are in an emergency situation.



Fig. 38 Center console: emergency flasher switch

- ▶ Press the switch  ⇒ fig. 38 to turn the emergency flashers on or off.

When the emergency flasher is on, all four turn signals blink at the same time. The turn signal indicator lights   in the instrument cluster, as well as the light in the emergency flasher switch  blink likewise. The emergency flasher also works when the ignition is turned off.

The emergency flashers will turn on automatically if you are in an accident where the airbag has deployed.

Tips

You should turn on the emergency flashers when:

- you are the last vehicle standing in a traffic jam so that any other vehicles coming can see you, or when
- your vehicle has broken down or you are in an emergency situation, or when
- your vehicle is being towed by a tow truck or if you are towing another vehicle behind you.

Adjusting the exterior lighting

The settings are adjusted in the MMI.

- ▶ Select: **CAR** function button > **Car systems** control button > **Vehicle settings** > **Exterior lighting**.

Automatic headlights

You can adjust the following settings in the **Automatic headlights** menu:

Headlights activation time - You can adjust if the headlights switch on **Early**, **Med.** or **Late** according to the sensitivity of the light sensor.

Audi adaptive light* - You can switch adaptive light **On** and **Off**.

Automatic high beams*

You can switch the high beam assist **on** and **off**.

Daytime running lights

USA models: You can switch the daytime running lights **on** and **off**.

Canada models: The function cannot be turned off. It is activated automatically each time the ignition is switched on. This menu item is shown “greyed out”.

Coming home, Leaving home

The coming home function illuminates the area outside the vehicle when you switch the ignition off and open the driver's door. To turn the function on, select **Lights when leaving car** > **On**.

The leaving home function illuminates the area outside the vehicle when you unlock the vehicle. To turn the function on, select **Lights when unlocking car** > **On**.

The coming home and leaving home functions only operate when it is dark and the light switch is in the **AUTO** position.

Turn signal and high beam lever

The lever on the left side of the steering column is used to operate the turn signals and the high beam as well as the headlight flasher.

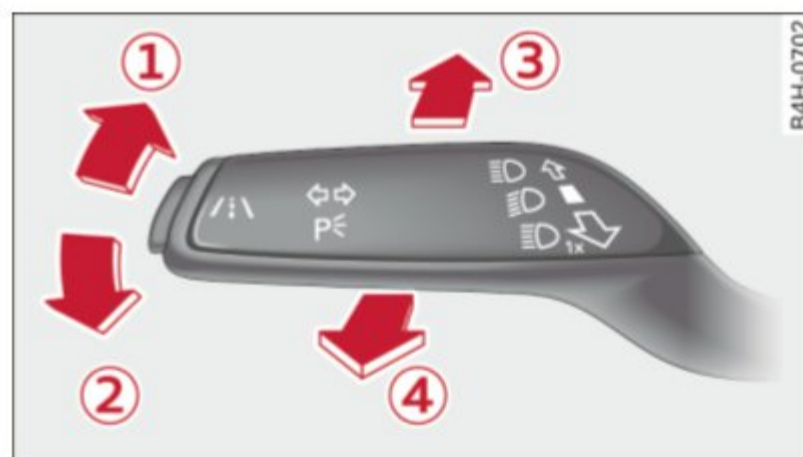

Fig. 39 Turn signal and high beam lever

The turn signal and high beam lever has the following functions:

Turn signals ① ②

- ▶ Push the lever up as far as it can go to turn on the right turn signal or down to turn on the left turn signal ⇒ *fig. 39*.
- ▶ Move the lever briefly until you meet resistance and release it to flash three times.
- ▶ Move the lever (up or down) until you meet resistance and hold it there to determine the flashing time for the turn signals.

High beam ③

- ▶ Push the lever forward to switch on the high beam (vehicles with high beam assist* ⇒ *page 49*).
- ▶ Pull the lever back towards you to switch off the high beam.

Headlight flasher ④

- ▶ Pull the lever toward the steering wheel to use the headlight flasher.

Notes on these features

- The *turn signals* only work with the ignition switched on. The indicator lights or in the instrument cluster ⇒ *page 11* also blink.
- After you have turned a corner, the turn signal switches off automatically.
- The *high beam* works only when the headlights are on. The indicator light in the

instrument cluster illuminates when the high beams are on.

- The *headlight flasher* works only as long as you hold the lever - even if there are no lights turned on. The indicator light  in the instrument cluster illuminates when you use the headlight flasher.

WARNING

Do not use the high beam or headlight flasher if you know that these could blind oncoming traffic.

High beam assist

Applies to vehicles: with high beam assist

The *high beam assist* automatically switches the high beams on or off, depending on the surroundings and traffic conditions.

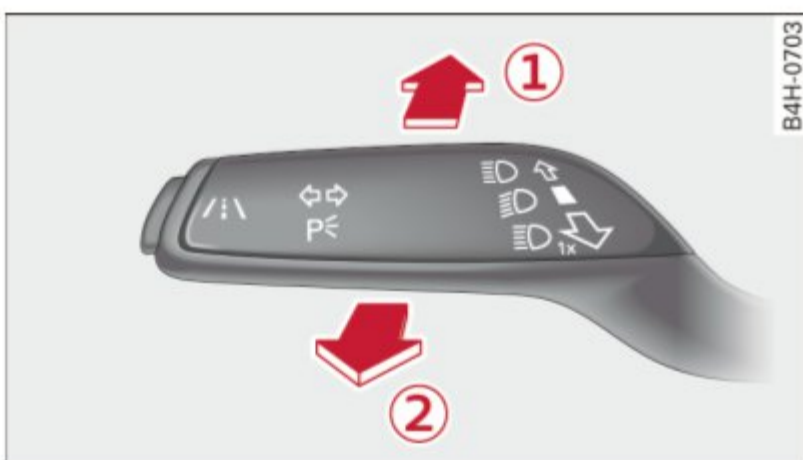



Fig. 40 Turn signal and high beam lever: Turning on and off the high beam assist

Activating high beam assist

Requirement: The light switch must be in the AUTO position, the low beam headlights must be on and the high beam assist must be switched on in the Infotainment \Rightarrow page 48.

- ▶ Press the lever into position **1** in order to activate the high beam assist. The indicator light  turns on in the instrument cluster display and the high beams switch on or off automatically. The indicator light  turns on if the high beams were switched on.

Switching the high beams on/off manually

Requirement: High beam assist is activated.

If the high beams did not switch on/off automatically when expected, you may instead switch them on/off manually:

- ▶ To switch the high beams on manually, press the lever into position **1**. The indicator light  turns on. To switch the high beams off again, pull the lever into position **2**.
- ▶ To switch the high beams off manually after they have turned on automatically, pull the lever into position **2**.

Operating the headlight flasher

- ▶ To operate the flashers while the high beam assist is active, pull the lever into position **2**. The high beam assist will remain active.

Messages in the instrument cluster display

Headlight assist: System fault

Drive to your authorized Audi dealer immediately to have the malfunction corrected. You can still switch the high beams on or off manually.

Headlight assist: Unavailable. No camera view

The camera view is blocked, for example by a sticker or debris.

The sensor is located between the interior rearview mirror and the windshield. Therefore, do not place any stickers in this area on the windshield.

Service setting

There is a different sensitivity setting for servicing. This setting can be activated by pressing and holding the button on the interior rearview mirror for more than 18 seconds. The LED next to the button blinks three times. If you have accidentally selected this service function, the original sensitivity will be automatically restored the next time you switch the ignition on.

WARNING

High beam assist is only intended to assist the driver. The driver is still responsible for controlling the headlights and switching the high beams on and off manually depending on traffic, lighting and visibility conditions. Failure to intervene manually may lead to risk of accident. It may be necessary to operate the high beams manually in the following situations, e.g.:

- For adverse weather conditions such as fog, heavy rain, blowing snow or spraying water.
- On roads where oncoming traffic may be partially obscured such as expressways.
- If there are individuals on the road with no lighting or poor lighting, such as cyclists.
- In tight curves and on steep slopes.
- In poorly lit areas.
- With strong reflectors such as signs.
- If the area of the windshield near the sensor is fogged over, dirty, icy or covered with a sticker.

Tips

- The high beam assist is active above a speed of approx. 25 mph (40 km/h).
- If after activation, your speed falls below approx. 15 mph (24 km/h), the high beams will automatically be switched off.

Interior lights

Front and rear interior lighting





Fig. 41 Headliner: Front interior lights



Fig. 42 Rear headliner: Reading light

Press the appropriate button ⇒ *fig. 41*:

 - Interior lighting on/off

 - Door contact switch. The interior lighting turns on automatically when you unlock the vehicle, open a door or switch the ignition off. The interior lighting turns off several seconds after you close the doors, when you lock the vehicle or when you switch the ignition on. When a door is open, the light turns off after a few minutes.

 - Reading lights on/off

 - Switching the rear reading lights on/off from the cockpit.

REAR MODE* - Switching the rear reading lights on/off from the cockpit: press the **REAR MODE** button and then the appropriate button  in the cockpit.

Ambience lighting

Applies to vehicles: with ambience lighting

You can select a color profile and brightness for the ambience lighting in various areas of the vehicle, called zones.

Turning ambience lighting on

- ▶ Select in the MMI: **CAR** function button > **Car systems** control button > **Vehicle settings** > **Interior lighting** > **On**.

Adjusting/turning off the brightness

- ▶ Select in the MMI: **CAR** function button > **Car systems** control button > **Vehicle settings** > **Interior lighting** > **Brightness**.

- ▶ Turn the knob to the desired vehicle area and press the knob. The bar that appears indicates the selected brightness.
- ▶ To increase or reduce the brightness, turn the knob and press it.

Selecting a color profile*

- ▶ Select in the MMI: **CAR** function button > **Car systems** control button > **Vehicle settings** > **Interior lighting** > **Color profile**.

The ambience lighting turns on when the function is activated in the MMI and when you turn the headlights on while the ignition is switched on.

Adjusting the brightness

You can adjust the brightness for the four zones **Front top**, **Front footwell**, **Rear top** and **Rear footwell** or for **All areas** at the same time.

Selecting a color profile

You can select from the **Ivory**, **Polar** and **Ruby/Polar** color profiles.

i Tips

The settings are automatically stored and assigned to the remote control key that is in use.

Instrument illumination

You can adjust the brightness of the instrument and display illumination.



Fig. 43 Instrument illumination

- ▶ Press the knob to release it.
- ▶ Turn the knob toward “-” or “+” to reduce or increase the brightness.

- ▶ Press the knob again to return it to its original position.

i Tips

The instrument illumination (for dials and needles) lights on when the ignition is switched on and the vehicle lights are turned off. As the daylight fades, the illumination of the dials likewise dims automatically and will go out completely when the outside light is very low. This feature is meant to remind you to switch on the headlights when outside light conditions become poor.

Vision

Sun visors



Fig. 44 Sun visor

The sun visors for the driver and passenger can be released from their brackets and turned toward the doors ⇒ *fig. 44* ①. They can also be moved back and forth lengthwise in this position.

The mirror light switches on when the cover over the vanity mirror ② opens.

There is a shade between the driver's and passenger's sun visors that can be used to cover the gap above the rearview mirror.

Sun Shade





Fig. 45 Cockpit: Sun shade switch





Fig. 46 Rear door: Sun shade button



Extending/retracting the rear window shade*

- ▶ To extend or retract the sun shade **from the cockpit**, press the  button in the center console ⇒ *fig. 45*.
- ▶ To extend or retract the sun shade **from the rear of the vehicle**, press the  button in the door ⇒ *fig. 46*.

Extending the rear door sun shades*

- ▶ Close the window in the rear door.
- ▶ To extend the sun shade **from the driver's seat**, pull the left/right rear power window switch  in the driver's door.
- ▶ To extend the sun shade from the **rear of the vehicle**, pull the power window switch  in the left/right rear door.

Retracting the rear door sun shades*

- ▶ To retract the sun shade **from the driver's seat**, press the left/right rear power window switch  in the driver's door.
- ▶ To retract the sun shade from the **rear of the vehicle**, press the power window switch  in the left/right rear door.

You can adjust the settings for the rear sun shade so the shade retracts automatically when you select the reverse gear. Select: **CAR** function button > **Car systems** control button > **Vehicle settings** > **Automatic rear blind** > **On**. The settings are automatically stored and assigned to the remote control key. The sun shade extends again as soon as the vehicle begins traveling forward at a speed greater than 9 mph (15 km/h), as long as the ignition has not been switched off in the meantime.

WARNING

When lowering or raising the sunshade, make sure there is nothing in its way and that it has a free path to travel. This could cause personal injury.

Tips

- Pressing the button  several times consecutively can trigger the overload protection. The sun shade can only be extended/retracted again after a brief waiting period.
- The rear window sun shade only functions when the vehicle interior is warmer than 14°F (-10°C).

Vanity mirror in the rear

Applies to vehicles: with vanity mirrors in the rear

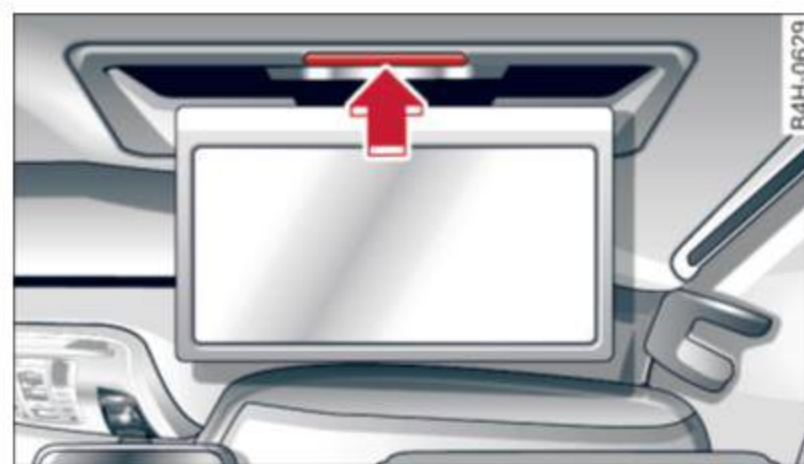

Fig. 47 Rear headliner: vanity mirror

- ▶ Press the button to fold the mirror open. The mirror lighting turns on automatically.
- ▶ To change the mirror's angle, move it forward/back with your hand.

Wiper and washer system

Switching the windshield wipers on

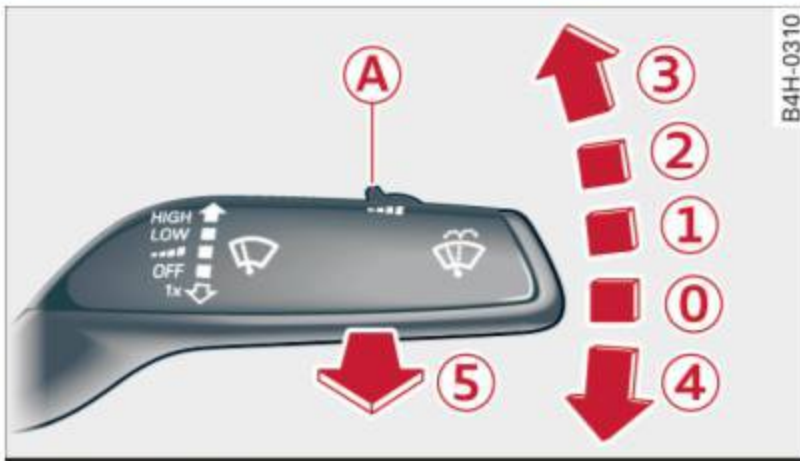

Fig. 48 Windshield wiper lever

Move the windshield wiper lever to the corresponding position:

- ① - Windshield wipers off
- ① - Rain sensor mode. The windshield wipers switch on once the vehicle speed exceeds approximately 2 mph (4 km/h) and it is raining. The higher the rain sensor sensitivity is set (switch **A** to the right), the earlier the windshield wipers react to moisture on the windshield. You can deactivate rain sensor mode in the MMI, which will then activate intermittent mode. Select: **CAR** function button > **Car systems** control button > **Driver assist** > **Rain sensor** > **Off**. In intermittent mode, you can adjust the interval time using the switch **A**.
- ② - Slow wiping
- ③ - Fast wiping
- ④ - Single wipe. If you hold the lever in this position longer, the wipers switch from slow wiping to fast wiping.
- ⑤ - Clean the windshield. The wipers wipe one time after several seconds of driving to remove water droplets. You can switch this function off by moving the lever to position **⑤** within 10 seconds after the afterwipe. The afterwipe function is reactivated the next time you switch the ignition on.

Cleaning the headlights. The headlight washer system* only functions when the headlights are on. If you move the lever to position **⑤**,

the headlights and the night vision system camera* are washed in intervals.

! WARNING

- The rain sensor is only designed to assist and support the driver. It remains entirely the driver's responsibility to monitor outside weather conditions and to manually activate the wipers as soon as rain or drizzle reduces visibility through the windshield.
- The windshield must not be treated with water-repellent materials. They can increase glare under poor visibility conditions such as wetness, darkness, or when the sun is low on the horizon. In addition, they can cause the windshield wipers to chatter.
- Properly functioning windshield wiper blades are required for a clear view and safe driving ⇒ *page 54, Replacing windshield wiper blades*.

! Note

- In the case of frost, check whether the windshield wiper blades are frozen to the windshield. Switching on the windshield wipers can damage the wiper blades!
- Prior to using a car wash, the windshield wiper system must be switched off (lever in position **①**). This helps to prevent unintentional switching on and damage to the windshield wiper system.
- Do not use the wipers to clear a frosted window. Using the wipers as a convenient ice scraper will destroy the wiper blades.

i Tips

- The windshield wipers are switched off when the ignition is off. Activate the windshield wipers after the ignition is switched back on by moving the windshield wiper lever to any position.
- Worn or dirty windshield wiper blades result in streaking. This can affect the

rain sensor function. Check your windshield wiper blades regularly.

- The washer fluid nozzles of the windshield washer system are heated at low temperatures when the ignition is on.
- When stopping temporarily, e.g. at a traffic light, the set speed of the windshield wipers is automatically reduced by one speed.

Cleaning windshield wiper blades

Clean the windshield wiper blades when they begin to leave streaks.

- ▶ Place the windshield wiper arms in the service position. Refer to ⇒ page 54.
- ▶ Use a soft cloth and glass cleaner to clean the windshield wiper blades.

WARNING

Dirty windshield wiper blades can impair your view. This can lead to accidents.

Replacing windshield wiper blades

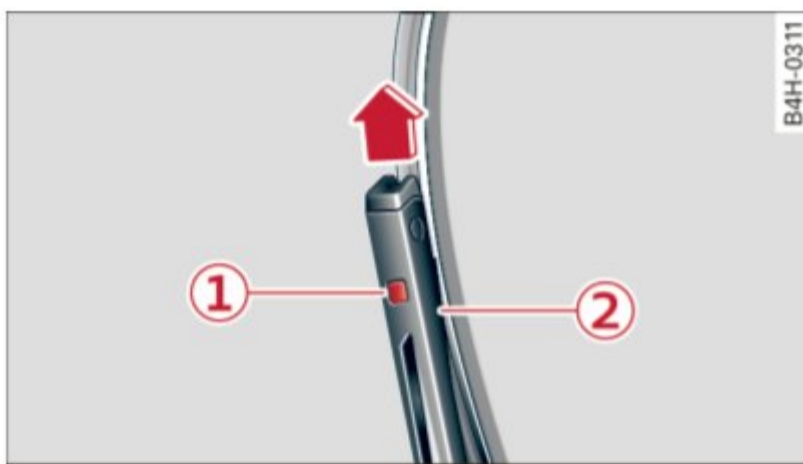

Fig. 49 Removing windshield wiper blades

Wiper service position/ Blade replacement position

- ▶ Switch the ignition off and move the windshield wiper lever to position ④ ⇒ page 53, fig. 48. The windshield wipers move into the service position.
- ▶ To bring the wipers back into the original position, switch the ignition on and press the windshield wiper lever.

You can also turn the service position on or off in the MMI:

- ▶ Switch the windshield wipers off (position ① ⇒ page 53, fig. 48).
- ▶ Select: **CAR** function button > **Car systems** control button > **Servicing & checks** > **Wiper service position** > **On**.

Removing the wiper blade

- ▶ Lift the windshield wiper arm up from the windshield.
- ▶ Press the locking knob ① ⇒ fig. 49 on the wiper blade. Hold the wiper blade firmly.
- ▶ Remove the wiper blade in the direction of the arrow.

Attaching the wiper blade

- ▶ Install the new wiper blade in the retainer on the wiper arm ② until you hear it click into place on the wiper arm.
- ▶ Place the wiper arm back on the windshield.
- ▶ Turn the service position off.

WARNING

For your safety, you should replace the wiper blades once or twice a year. See your authorized Audi dealer for replacement blades.

Note

- The windshield wiper blades must only be folded away when in the service position! Otherwise, you risk damaging the paint on the hood or the windshield wiper motor.
- You should not move your vehicle or press the windshield wiper lever when the wiper arms are folded away from the windshield. The windshield wipers would move back into their original position and could damage the hood and windshield.
- To help prevent damage to the wiper system, always loosen blades which are frozen to the windshield before operating wipers.
- To help prevent damage to wiper blades, do not use gasoline, kerosene, paint thinner, or other solvents on or near the wiper blades.

- To help prevent damage to the wiper arms or other components, do not attempt to move the wipers by hand.

i Tips

- Commercial hot waxes applied by automatic car washes affect the cleanability of the windshield.
- You can also use the service position, for example, if you want to protect the windshield from icing by using a cover.
- You cannot activate the service position when the hood is open.

Mirrors

Adjusting the exterior mirrors



Fig. 50 Forward section of driver's armrest: power mirror controls

Turn the knob to the desired position:

 - In this position, you can adjust the driver's and front passenger's exterior mirrors by turning the knob in the desired direction.

 - The mirrors are heated depending on the outside temperature.

 - The exterior mirrors fold in. In the MMI, you can select if the mirrors fold in automatically when you lock the vehicle ⇒ [page 34](#).

Tilt function for the passenger's mirror

To help you see the curb when backing into a parking space, the surface of the mirror tilts slightly. The knob must be in the  position for this to happen.

You can adjust the tilted mirror surface by turning the knob in the desired direction. When you move out of reverse and into another

gear, the new mirror position is stored and assigned to the key you are using.

The mirror goes back into its original position once you drive forward faster than 9 mph (15 km/h) or switch the ignition off.

! WARNING

- Curved (i. e. convex) mirror surfaces increase your field of view. Remember that vehicles or other objects will appear smaller and farther away than when seen in a flat mirror. If you use this mirror to estimate distances of following vehicles when changing lanes, you could estimate incorrectly and cause an accident.

! Note

- If the mirror housing is moved unintentionally (for example, while parking your vehicle), then you must first fold the mirror electrically. Do not readjust the mirror housing manually. You could damage the motor which controls the mirror.
- If you wash the vehicle in an automatic car wash, you must fold the exterior mirrors in to reduce the risk of damage to the mirrors. Never fold power folding exterior mirrors by hand. Only fold them in and out using the power controls.

i Tips

- The exterior mirror settings are stored with the memory function* ⇒ [page 66](#).
- If there is a malfunction in the electrical system, you can still adjust the exterior mirrors by pressing the edge of the mirror.

Dimming the mirrors

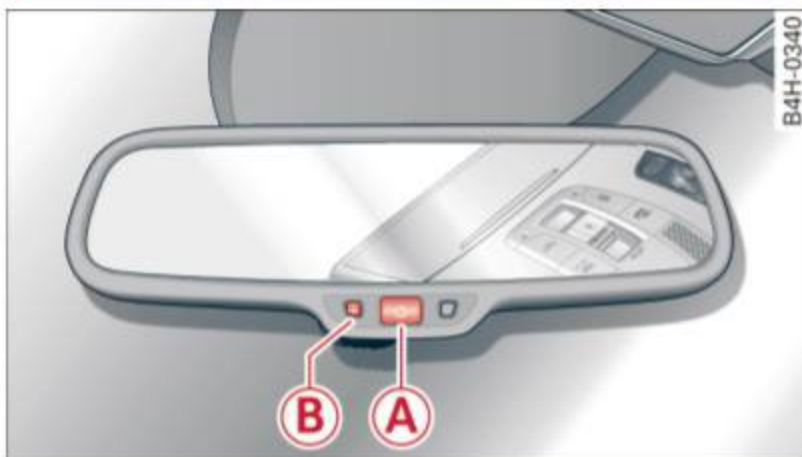

Fig. 51 Automatic dimming rearview mirror

- ▶ To dim the rearview mirror and both exterior mirrors, press the **A** button. The diode **B** turns on. The rearview and exterior mirrors dim automatically when light shines on them, for example from headlights on a vehicle to the rear.

WARNING

Electrolyte fluid can leak from automatic dimming mirrors if the glass is broken. Electrolyte fluid can irritate skin, eyes and respiratory system.

- Repeated or prolonged exposure to electrolyte can cause irritation to the respiratory system, especially among people with asthma or other respiratory conditions. Get fresh air immediately by leaving the vehicle or, if that is not possible, open windows and doors all the way.
- If electrolyte gets into the eyes, flush them thoroughly with large amounts of clean water for at least 15 minutes; medical attention is recommended.
- If electrolyte contacts skin, flush affected area with clean water for at least 15 minutes and then wash affected area with soap and water; medical attention is recommended. Thoroughly wash affected clothing and shoes before reuse.
- If swallowed and person is conscious, rinse mouth with water for at least 15 minutes. Do not induce vomiting unless instructed to do so by medical professional. Get medical attention immediately.

Note

Liquid electrolyte leaking from broken mirror glass will damage any plastic surfaces it comes in contact with. Clean up spilled electrolyte immediately with clean water and a sponge.

Tips

- Switching off the dimming function of the inside rear view mirror also deactivates the automatic dimming function of the exterior mirrors.
- Automatic dimming for the mirror only operates properly if the sun shade* for the rear window is not in use or the light striking the inside mirror is not hindered by other objects.
- The automatic dimming mirrors do not dim when the interior lighting is turned on or the reverse gear is selected.

Digital compass

Switching the compass on and off

Applies to vehicles: with digital compass

The compass direction is shown in the rearview mirror.



Fig. 52 Rearview mirror: Digital compass activated

- ▶ To switch the compass on or off, press and hold the button **A** until the compass display in the mirror ⇒ *fig. 52* appears or disappears.

The digital compass only works when the ignition is on. The directions are indicated with abbreviations: **N** (north), **NE** (northeast), **E** (east), **SE** (southeast), **S** (south), **SW** (southwest), **W** (west), **NW** (northwest).

WARNING

The digital compass is to be used as a directional aid only. Even though you may want to look at it while you are driving, you must still pay attention to traffic, road and weather conditions as well as other possible hazards.

Tips

To prevent inaccurate compass readings, do not bring any remote controls, electrical devices or metallic objects near the mirror.

Adjusting the magnetic zone

Applies to vehicles: with digital compass

The magnetic zone must be adjusted correctly for the compass to read accurately.

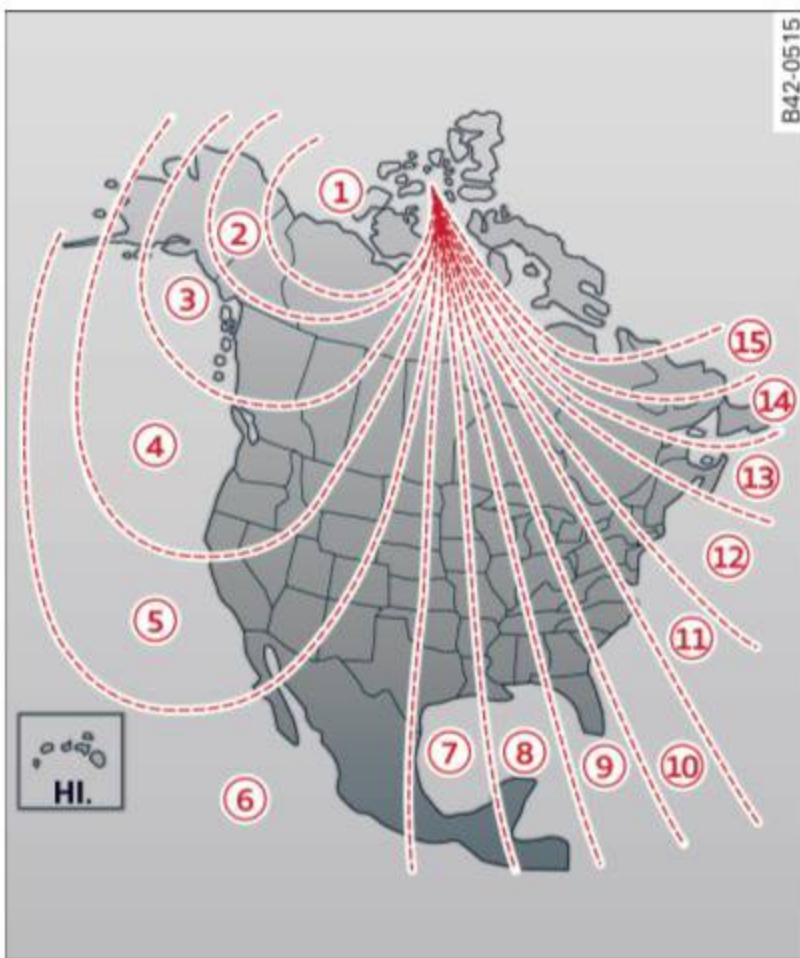





Fig. 53 Magnetic zone map

- ▶ Press and hold the button  ⇒ page 56, fig. 52 until the number of the magnetic zone appears in the rearview mirror.
- ▶ Press the button  repeatedly to select the correct magnetic zone. The selection mode turns off after a few seconds.

Calibrating the compass

Applies to vehicles: with digital compass

You must recalibrate the compass if it does not display the correct direction.

- ▶ Press and hold the button  until a **C** appears in the rearview mirror.
- ▶ Drive in a circle at about 6 mph (10 km/h) until a direction is displayed in the rearview mirror.

WARNING

To avoid endangering yourself and other drivers, calibrate the compass in an area where there is no traffic.

Seats and storage

General recommendations

Why is your seat adjustment so important?

The safety belts and the airbag system can only provide maximum protection if the front seats are correctly adjusted.

There are various ways of adjusting the front seats to provide safe and comfortable support for the driver and the front passenger. Adjust your seat properly so that:

- you can easily and quickly reach all the switches and controls in the instrument panel
- your body is properly supported thus reducing physical stress and fatigue
- the safety belts and airbag system can offer maximum protection ⇒ *page 153*.

In the following sections, you will see exactly how you can best adjust your seats.

There are special regulations and instructions for installing a child seat on the front passenger's seat. Always follow the information regarding child safety provided in ⇒ *page 177, Child Safety*.

WARNING

Incorrect seating position of the driver and all other passengers can result in serious personal injury.

- Always keep your feet on the floor when the vehicle is in motion – never put your feet on top of the instrument panel, out of the window or on top of the seat cushion. This applies especially to the passengers. If your seating position is incorrect, you increase the risk of injury in the case of sudden braking or an accident. If the airbag inflates and the seating position is incorrect, this could result in personal injury or even death.
- It is important for both the driver and front passenger to keep a distance of at

least 10 inches (25 cm) between themselves and the steering wheel and/or instrument panel. If you're sitting any closer than this, the airbag system cannot protect you properly. In addition, the front seats and head restraints must be adjusted to your body height so that they can give you maximum protection.

- Always try to keep as much distance as possible between yourself and the steering wheel or instrument panel.
- Do not adjust the driver's or front passenger's seat while the vehicle is moving. Your seat may move unexpectedly, causing sudden loss of vehicle control and personal injury. If you adjust your seat while the vehicle is moving, you are out of position.

Driver's seat

The correct seat position is important for safe and relaxed driving.

We recommend that you adjust the driver's seat in the following manner:

- ▶ Adjust the seat in fore and aft direction so that you can easily push the pedals to the floor while keeping your knees slightly bent ⇒  in *Why is your seat adjustment so important?* on *page 58*.
- ▶ Adjust the backrest so that when you sit with your back against the backrest, you can still grasp the top of the steering wheel.
- ▶ Adjust the head restraint so the upper edge is as even as possible with the top of your head. If that is not possible, try to adjust the head restraint so that it is as close to this position as possible ⇒ *page 65*.

WARNING

Never place any objects in the driver's footwell. An object could get into the pedal area and interfere with pedal function. In case of sudden braking or an accident, you would not be able to brake or accelerate.

Front passenger's seat

Always move the front passenger seat into the rearmost position.

To avoid contact with the airbag while it is deploying, do not sit any closer to the instrument panel than necessary and always wear the three-point safety belt provided adjusted correctly. We recommend that you adjust the passenger's seat in the following manner:

- ▶ Bring the backrest up to an (almost) upright position. **Do not** ride with the seat reclined.
- ▶ Adjust the head restraint so the upper edge is as even as possible with the top of your head. If that is not possible, try to adjust the head restraint so that it is as close to this position as possible ⇒ *page 65*.
- ▶ Place your feet on the floor in front of the passenger's seat.

Front seats

Controls

Moving the seat forward or back and adjusting the height, backrest angle and seat angle.

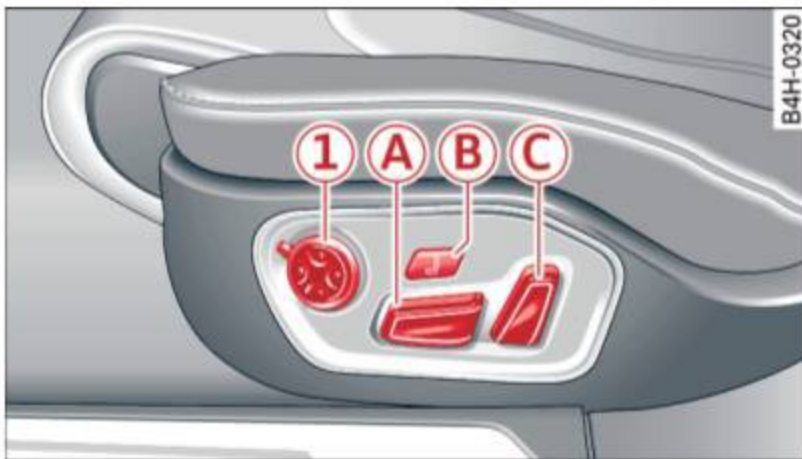

Fig. 54 Front seat: adjusting the seat

- Ⓐ - Moving the seat forward/back: press the button forward/back ⇒ ⚠.
- Ⓐ - Moving the seat up/down: press the button up/down ⇒ ⚠. To adjust the front section of the seat, press the front button up/down ⇒ ⚠. To adjust the rear section of the seat, press the rear button up/down ⇒ ⚠.
- Ⓑ - Turn the massage function on/off. You can select the type of massage using the multifunction button ⇒ *page 60*.

Ⓒ - Backrest forward/back: press the button forward/back ⇒ ⚠.

Ⓒ - Comfort head restraints ⇒ *page 65*, ⇒ ⚠.

① - Multifunction button ⇒ ⚠, ⇒ *page 60*.

⚠ WARNING

- Never adjust the driver's or front passenger's seat while the vehicle is moving. If you do this while the vehicle is moving, you will be out of position. Always adjust the driver's or front passenger's seat when the vehicle is not moving.
- Be careful when adjusting the seat height. Check to see that no one is in the way, or serious injury could result!
- Because the seats can be electrically adjusted with the ignition off, never leave children unattended in the vehicle. Unsupervised use of the electric seat adjustments may cause serious injury.
- To reduce the risk of injury in the case of sudden braking or accident, front passengers must never ride in a moving vehicle with the backrest reclined. Safety belts and the airbag system only offer maximum protection when the backrest is upright and the safety belts are properly positioned on the body. The more the backrest is reclined, the greater the risk of personal injury from an incorrect seating position and improperly positioned safety belts.

Multifunction button

Applies to vehicles: with memory function

You can adjust the massage function, upper section of the backrest, lumbar support, side bolsters, seating surface and safety belt height using the multifunction button.

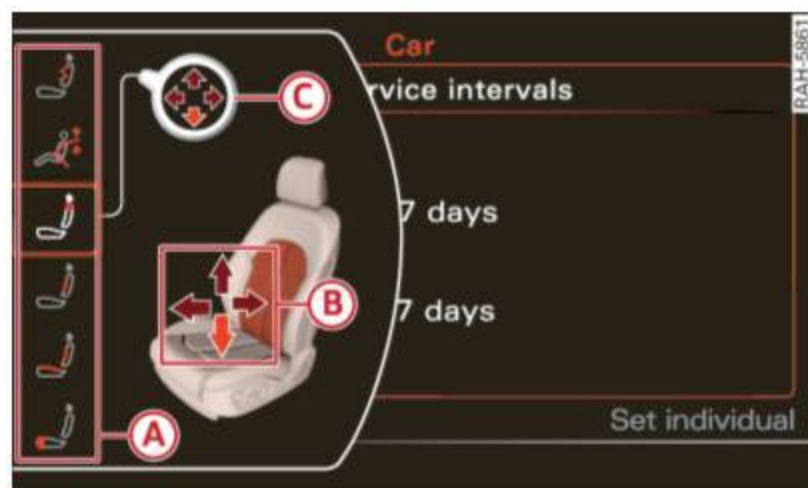

Fig. 55 MMI display: seat settings

Operating

- ▶ The MMI displays the possible seat settings (A) when you turn the multifunction button (1) ⇒ page 59, fig. 54 to the left or right ⇒ fig. 55, ⇒ ⚠.
- ▶ To select a seat setting, turn the multifunction button (1) until the desired seat setting is highlighted with a red border.
- ▶ The arrows (B) indicate the possible adjustments. For example, to move the lumbar support down, press the multifunction button (1) down. The corresponding arrow (C) lights up.

The following seat settings (A) are possible:

Massage function* - Massage type **Wave, Knocking, Stretch, Lumbar, Shoulder** or **Off**.

You can set the massage strength level from 1 to 5. You can turn the selected massage on/off using the button (B) ⇒ page 59, fig. 54.

Safety belt height adjustment* - Moving the safety belt up/down ⇒ page 150, ⇒ ⚠.

Upper backrest - Moving the angle of the upper section of the backrest forward/back ⇒ ⚠.

Lumbar support - Moving the lumbar support up/down and making it firmer/softer ⇒ ⚠.

Side bolsters* - Increasing/reducing the side support in the seat using the side bolsters on the seating surface and backrest ⇒ ⚠.

Seating surface - Making the seating surface longer/shorter ⇒ ⚠.

⚠ WARNING

- Never adjust the driver's or front passenger's seat while the vehicle is moving. If you do this while the vehicle is moving, you will be out of position. Always adjust the driver's or front passenger's seat when the vehicle is not moving.
- Be careful when adjusting the seat height. Check to see that no one is in the way, or serious injury could result!
- Because the seats can be electrically adjusted with the ignition off, never leave children unattended in the vehicle. Unsupervised use of the electric seat adjustments may cause serious injury.
- To reduce the risk of injury in the case of sudden braking or accident, front passengers must never ride in a moving vehicle with the backrest reclined. Safety belts and the airbag system only offer maximum protection when the backrest is upright and the safety belts are properly positioned on the body. The more the backrest is reclined, the greater the risk of personal injury from an incorrect seating position and improperly positioned safety belts.

i Tips

- The massage function switches off automatically after approximately 10 minutes.
- In vehicles with the reclining rear seat, only the safety belt height and the seating surface can be adjusted on the front passenger seat using the multifunction button.
- The side bolsters* deflate when the driver's door is opened. This allows you to

enter and exit comfortably. The side bolsters inflate again once you begin driving.

Armrest

There is a storage compartment under the armrest.

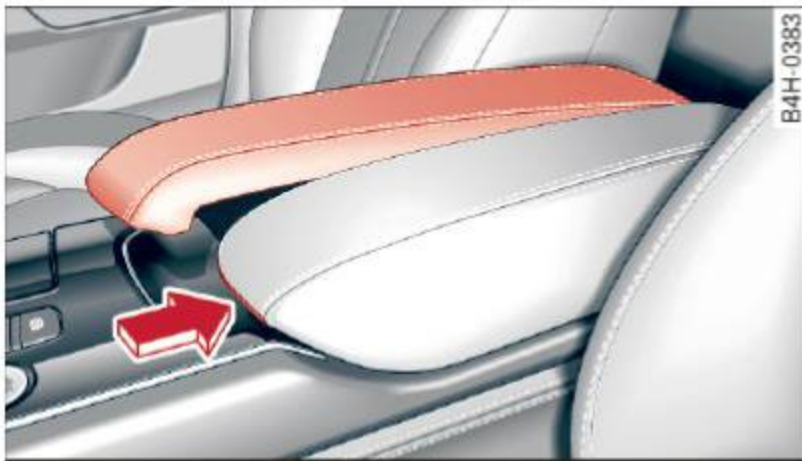

Fig. 56 Cockpit: center armrest

Opening the storage compartment

- ▶ Press the button -arrow- and move the armrest up ⇒ *fig. 56*.

Adjusting the armrest

- ▶ To move the armrest forward and up, press the button -arrow- while pulling the armrest into the desired position.
- ▶ To bring the armrest back into its original position, press the button -arrow- while pressing the armrest down.

Please note that the driver's arm movements may be restricted with the armrest folded down. For this reason, the armrest should not be folded down when driving in city traffic.

Rear seats

General information

Safe transportation of passengers on the rear seats requires proper safety precautions.

All passengers on the rear seats must be seated in compliance with the safety guidelines explained in ⇒ *page 145* and ⇒ *page 153*. The correct seating position is critical for the safety of front *and* rear seat passengers alike ⇒ *page 138*.

! WARNING

- Occupants in the front *and* rear seats must always be properly restrained.
- Do not let anyone ride in the vehicle without the head restraints provided. Head restraints help to reduce injuries.
- Loose items inside the passenger compartment can fly forward in a crash or sudden maneuver and injure occupants. Always store articles in the luggage compartment and use the tie-down eyelets.
- Read and heed all WARNINGS
⇒ *page 138, Proper seating positions for passengers in rear seats.*

Adjusting the rear seats

Applies to vehicles: with comfort seats

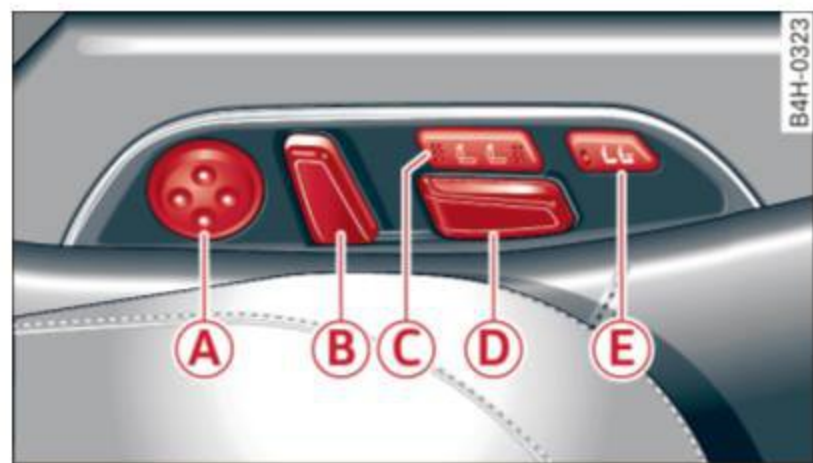

Fig. 57 Right rear seat: seat adjustment buttons

- Ⓐ - Adjusting the lumbar support: press the button to the left/right to adjust the lumbar support curvature ⇒ . Press the button up/down to adjust the height of the lumbar support ⇒ .
- Ⓑ - Moving the upper section of the backrest forward/back. Press the button forward/back ⇒ .
- Ⓒ - Massage function*: to select the “pulsating” massage function, press the button forward. To select the “wave” massage function, press the button back. If three lights in the button turn on, the massage is at the strongest level. To reduce the massage level, press the button again. To turn the massage function off, press the button again until all of the lights turn off.

ⓓ - Moving the seat forward/back: press the button forward/back ⇒ ⚠.

ⓓ - Moving the seat up/down: press the button up/down ⇒ ⚠.

ⓔ - Switching front passenger seat adjustment on/off: this function must be activated in the MMI ⇒ *page 64*, ⇒ ⚠. To switch front passenger seat adjustment on, press the button. You can now adjust the front passenger seats using the buttons ⓑ and ⓓ. If you do not press the buttons ⓑ or ⓓ, front passenger seat adjustment switches off automatically after approximately ten seconds.

⚠ WARNING

- The power adjustment for the individual seats also works with the ignition. For this reason, children should never be left unattended in the vehicle - they could be injured!
- Exercise caution when adjusting the seats. Unsupervised or careless seat adjustment can pinch fingers or hands causing injuries.
- Vehicles with a pass through in the center console have seating for four. The

long center console between the two rear seats is **not** a seating position. Therefore, a safety belt is not provided.

! Note

If a child seat is attached to one of the rear seats, this seat must not be adjusted using the power controls under any circumstances. The easy entry function for this seat must also be deactivated in the MMI ⇒ *page 64*. The child seat as well as the rear seat can be damaged by the adjustment process.

i Tips

- The massage function switches off automatically after approximately 10 minutes.
- If you cannot move the front passenger seat, it may be because
 - the front passenger's seat memory function is switched off ⇒ *page 67* or
 - the child safety lock is switched on (the ☒ button ⇒ *page 41* or the right 👤 button ⇒ *page 41* lights up in the driver's door), or
 - the front passenger seat adjustment is switched off in the MMI ⇒ *page 64*.

Reclining rear seat overview

Applies to vehicles: with reclining rear seat

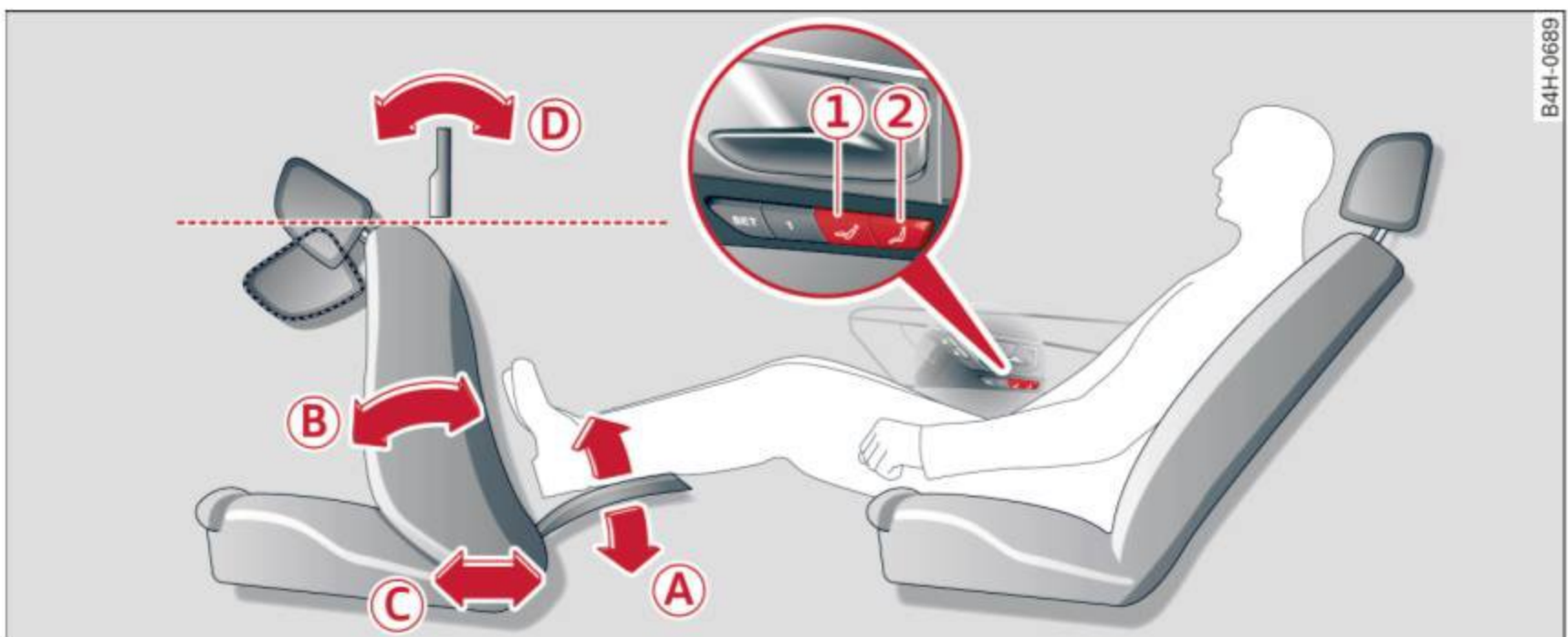

Fig. 58 Rear door: adjusting the reclining position

① - Adjusting the reclining position

② - Adjusting the standard position

- Ⓐ - Folding the leg support up/down
- Ⓑ - Leg support steeper/flatter
- Ⓒ - Leg support forward/back
- Ⓓ - Adjusting the display

Operating the reclining rear seat

Applies to vehicles: with reclining rear seat

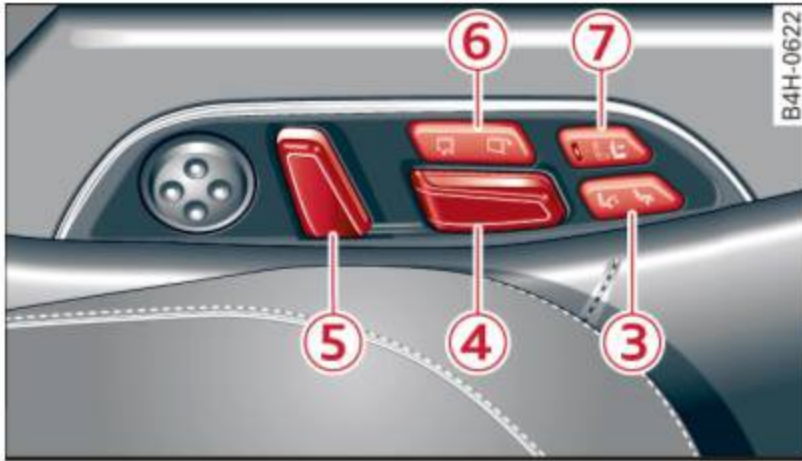

Fig. 59 Rear center console: seat adjustment buttons

Reclining position on/off

① - Adjusting the reclining position: press and hold the button ① ⇒ page 62, fig. 58 until your seat and the front passenger's seat reach their end positions ⇒ page 62, fig. 58. Depending on the last setting, the leg support may fold out at the same time. The front passenger seat's can no longer be used in the reclining position ⇒ ⚠.

② - Adjusting the standard position: press and hold the button ② until the front passenger's seat reaches its end position and its head restraint is upright. The leg support folds in at the same time ⇒ ⚠.

You can adjust the leg support or fold the display forward in the reclining position:

Adjusting the leg support

Ⓐ - Folding the leg support out/in: press and hold the left/right button ③ ⇒ fig. 59 until the leg support reaches the desired position.

Ⓑ - Leg support steeper/flatter: Activate front passenger's seat adjustment with the button ⑦. To adjust the front passenger's seat backrest and the leg support, press the button ⑤ forward/back.

Ⓒ - Leg support forward/back: Activate front passenger's seat adjustment with the button ⑦. To adjust the front passenger's seat and leg support forward/back, press the button ④ forward/back.

Adjusting the display

Ⓓ - Tilting the display forward/back: press and hold the left/right button ⑥ until the display reaches the desired position.

You can fold the display forward so that you have a clear view of the roadway. With the seat in the reclining position, press and hold the right button ⑥ until the display is folded forward. Make sure the driver has a clear view of the exterior mirrors. If so, confirm the question in the MMI with Yes. If you answer No or do not respond to the question, the display will return to the upright position.

Adjusting the front passenger's seat



⑦ - Make sure that the front passenger's seat adjustment is switched on in the Infotainment system ⇒ page 64. Activate the front passenger's seat adjustment with the button ⑦. You can now adjust the passenger's seat forward/back and the backrest using the buttons ④ and ⑤. With buttons ①/②, you can adjust the passenger's seat to the reclining/upright position. If you do not adjust the passenger's seat, the button ⑦ will deactivate automatically after about 10 seconds.

⚠ WARNING

Do not use the front passenger's seat for seating when it is in the reclining position. This increases the risk of serious injury or death.

- Never adjust the reclining position when the front passenger's seat is occupied. This increases the risk of injury.
- Do not tilt the display if the driver's view of the right exterior mirror will be obstructed.
- Make sure the area between the leg support and the front passenger's seat backrest is clear before folding the leg support in so that you are not pinched.

i Tips

- If you cannot move the seat into the reclining position, it may be because
- the front passenger's seat memory function is switched off ⇒ *page 67* or
 - the child safety lock is switched on (the  button ⇒ *page 41* or the right  button ⇒ *page 41* lights up in the driver's door), or
 - the front passenger seat adjustment is switched off in the MMI ⇒ *page 64*.

Massage function remote control

Applies to vehicles: with reclining rear seat and massage function

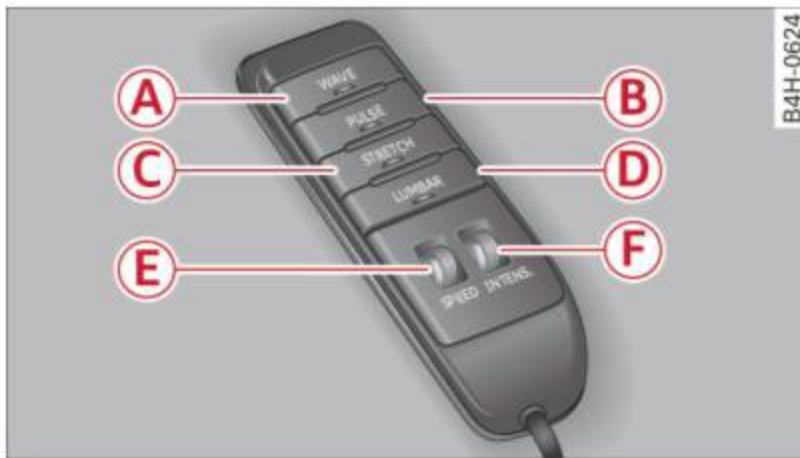

Fig. 60 Remote control: reclining seat massage functions

The remote controls are located in the rear center console ⇒ *page 68, fig. 65*. The massage function is only available when the ignition is switched on.

- ▶ To open the remote control compartment, press the left button and fold the center armrest upward.
- ▶ To adjust the massage type, press the appropriate button **A** - **D**. The LED in the button will turn on.
- ▶ To adjust the speed/intensity, turn the thumbwheel **E**/**F**. The LEDs indicate the speed/intensity.
- ▶ Press the selected massage type again to switch the massage function off.

Massage types

- A** - Wave
- B** - Pulse
- C** - Stretch

D - Lumbar

i Tips

- The massage function switches off automatically after approximately 10 minutes.
- If you activate a massage type again, the last selected intensity and speed will be selected.

Comfort settings

Applies to vehicles: with comfort seats in the rear

You can adjust settings for the rear seat from the cockpit using the MMI.

- ▶ Select **CAR** function button > **Car systems** control button > **Vehicle settings** > **Seats** > **Rear seats**.

Factory settings position - This function moves the outer rear seats and the front passenger seatback into the factory settings position.

Entry assistance - **Entry assistance** makes it easier to enter and exit the rear seat more comfortably. When the function is activated, the rear seat moves all the way back automatically when the corresponding door opens.

Front passenger seat adjustment* - If the function is activated in the MMI, the front passenger seat can be adjusted from the rear seat ⇒ *page 61, fig. 57*.

Head restraints

Adjusting the head restraints

Head restraints that are adjusted according to body size, along with the safety belt, offer effective protection.



Fig. 61 Comfort head restraints: adjusting the side bolsters

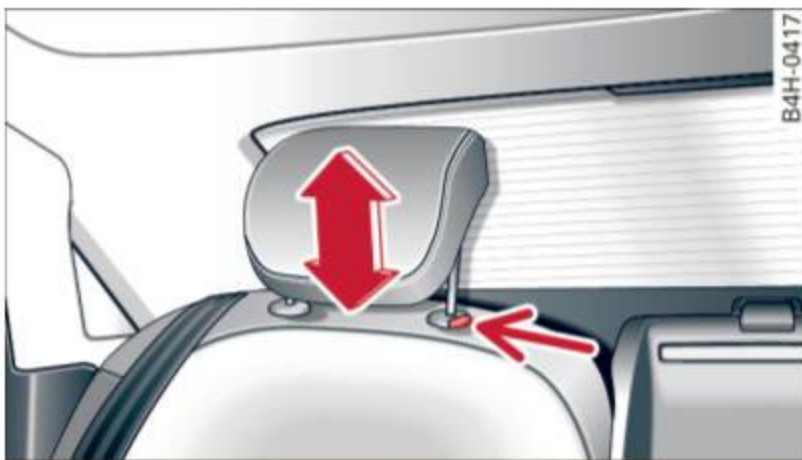



Fig. 62 Outer rear seat: adjusting the head restraint

Adjust the head restraint so the upper edge is as even as possible with the top of your head. If that is not possible, try to adjust the head restraint so that it is as close to this position as possible ⇒ page 65.

Adjusting front head restraints

- ▶ To adjust the height of the front head restraints, press/push the button  ⇒ page 59, fig. 54 up/down ⇒ .
- ▶ Vehicles with reclining rear seat: Grasp the sides of the passenger's head restraint with both hands and slide it upward/downward.

Adjusting rear head restraints (adjustable head restraints)

The center rear head restraint is not adjustable.

- ▶ Grasp the sides of the head restraint with both hands and slide it upward until you feel it click into place ⇒ .
- ▶ To lower the head restraints, press button - small arrow - ⇒ fig. 62 and slide the head restraint all the way down.

Adjusting the side bolsters*

- ▶ To adjust the side bolsters*, press them into the desired position ⇒ fig. 61.

Refer to ⇒ page 139, *Proper adjustment of head restraints* for guidelines on how to adjust the height of the front head restraints to suit the occupant's body size.

WARNING

- All seats are equipped with head restraints. Driving without head restraints or with head restraints that are not properly adjusted increases the risk of serious or fatal neck injury dramatically.
- Read and heed all WARNINGS ⇒ page 139, *Proper adjustment of head restraints*.
- Vehicles with a pass through in the center console have seating for four. The long center console between the two rear seats is **not** a seating position. Therefore, a safety belt is not provided.

Tips

- To prevent the head restraints from running into the headliner, they retract automatically when moving the seat forward or upward.
- Correctly adjusted head restraints and safety belts are an extremely effective combination of safety features.

Seat memory

Description

Applies to vehicles: with memory function

The memory function allows you to quickly and easily store and recall personal seating profiles for the driver, front passenger and outer rear seats*. The memory function is operated through the master key and the memory buttons in the driver's/front passenger's doors and the rear doors*.

The driver's seating profile is stored and assigned to the master key each time the vehicle is locked. The seating profile is recalled automatically when the vehicle is unlocked. If two

people use one vehicle, it is recommended that each person always uses "their own" master key.

Two seating profiles can be stored in each of the driver's/front passenger's doors and one seating profile in each of the rear doors*. Once stored, these seating profiles can be recalled at any time.

The following settings are stored:

	Remote control master key	Memory button		
	Driver	Driver	Front passenger	Outer rear seats*
Seat	X	X	X	X
Head restraint	X	X	X	
Steering wheel*	X	X		
Safety belt*	X	X	X	
Both exterior rear-view mirrors*	X	X		

There are two additional buttons in the rear doors* that can be used to recall two stored seating profiles ⇒ *page 67*.

Remote control key

Applies to vehicles: with memory function

To assign the driver's seat settings to the remote control key when locking the vehicle, the function must be switched on.

- ▶ Select: **CAR** function button > **Car systems control button** > **Vehicle settings** > **Seats** > **Driver seat** > **Remote control key** > **On**.

Tips

If you do not want another driver's settings to be assigned to the remote control key, switch off the memory function using the MMI or the **OFF** button ⇒ *page 67*.

Memory buttons

Applies to vehicles: with memory function



Fig. 63 Driver's door: memory function buttons



Fig. 64 Rear door: memory function buttons

The memory buttons are located in the driver's/front passenger's door and in the rear doors*.

Storing seating profiles

- ▶ To store a seating profile, press the **SET** button and then one of the memory buttons.
- ▶ To recall a seating profile, press and hold the memory button until the seat is adjusted to the stored settings.
- ▶ To switch the memory function for the driver or front passenger off, press the **OFF** button. The word **OFF** lights up when the memory function is switched off. Seating profiles will not be stored.

Adjusting the reclining position/standard position

- ▶ To adjust the reclining position, press and hold the **(A)** button until the seat moves into the end position.
- ▶ To adjust the standard position, press and hold the **(B)** button until the seat moves into the end position.

! WARNING

- For safety reasons, the seat setting should only be recalled when the vehicle is stationary - otherwise you risk having an accident.
- If necessary, you stop the process by pressing the **OFF** button or any of the memory buttons.

Adjusting the front passenger seat in the MMI

Applies to vehicles: with memory function

The driver can adjust the position of the front passenger seat.

Adjusting the front passenger seat from the driver's side

- ▶ Select: **CAR** function button > **Car systems** control button > **Vehicle settings** > **Seats** > **Front passenger seat** > **Adjust seat position**.
- ▶ You can now adjust the front passenger seat using the buttons on the driver's seat
⇒ page 59, fig. 54.

Matching the position of the driver's seat

- ▶ To adjust the front passenger seat to match the driver's seat settings, select the **CAR** function button > **Car systems** control button > **Vehicle settings** > **Seats** > **Front passenger seat** > **Symmetry to driver seat**.
- ▶ Press and hold the control knob until the adjustment process is complete.

i Tips

When matching seat settings, the settings for the lumbar support and seating surface will not transfer to the front passenger's seat.

Full-length center console

Overview

Applies to vehicles: with full-length center console

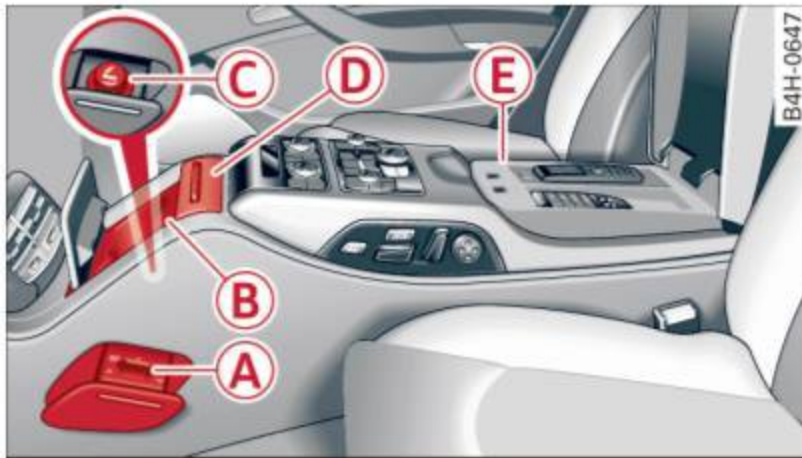

Fig. 65 Rear: full-length center console

- Ⓐ - 115 volt socket ⇒ *page 68*
- Ⓑ - cupholder ⇒ *page 75*
- Ⓒ - 12 volt socket ⇒ *page 74*
- Ⓓ - Folding table ⇒ *page 69*
- Ⓔ - center armrest and storage compartments: to open the deep compartment, press the right button and fold the center armrest upward. To open the compartment for the massage function remote control* ⇒ *page 64* and for the telephone*, press the left button and fold the center armrest upward.

115-volt socket

Applies to vehicles: with 115-volt socket

The 115-volt socket can only be used when the engine is running ⇒ ⚠. When you push the connector all the way into the socket, the child safety mechanism releases and current flows through the socket.

Equipment that can be connected

Electrical devices can be connected to the 115 volt socket in the vehicle. Power consumption at the 115-volt socket must not exceed 150 watts (300 watts peak). Check the power consumption of the equipment on the model plate.

LED on the socket

- The socket is ready for use when the LED is green.
- If the LED blinks red, there is a malfunction. The socket will switch off automatically due to overcurrent or overheating. The socket will switch on again automatically after a cool-down period. Any devices that are connected and switched on will activate again automatically ⇒ ⚠.

⚠ WARNING

- The sockets and the electrical accessories connected to them operate only when the ignition is switched on. Incorrect usage can lead to serious injuries or burns. To reduce the risk of injuries, never leave children unattended in the vehicle with the vehicle key.
- Heavy equipment or plugs with integrated power supply units can damage the socket and lead to injuries.
- Store all connected equipment securely while the vehicle is moving so that they cannot be thrown through the vehicle in the event of a braking maneuver or an accident.
- Never spill any liquids on the socket. If any moisture gets into the socket, make certain that all the moisture has dried up before using the socket again.
- Equipment that is connected to the vehicle socket can heat up more than it does when connected to the public grid.
- When using adapters and extension cords, the child safety for the 115-volt socket is disabled and the socket is live.
- Never insert anything other than the plug of an appropriate electrical accessory into the socket, especially things that conduct electricity, e.g. metal pens, knitting needles, etc. into the contacts of the 115-volt socket.
- Turn the electrical equipment off if the socket has switched off because of overheating.

! Note

- Always follow the manufacturer's instructions for all electrical accessories you want to use with the electrical socket!
- Do not connect lamps that contain a neon tube. For technical reasons the lamp may be damaged.
- Do not connect any 230-volt equipment to the 115-volt socket. The equipment may be damaged. If necessary, check the permissible voltage for the equipment on the model label.
- In the case of some power packs, e.g. for a laptop computer, the built-in overcurrent shutoff prevents it from being switched on because of excessive start-up current. In this case, disconnect the power pack from the consumer and reconnect it after about 10 seconds.

i Tips

- Unshielded equipment may cause interference in the radio and the vehicle electronics.
- Some equipment may work properly because of the reduced power (wattage), available from the socket.

Folding table in the center console

Applies to vehicles: with folding table in the center console

The folding table is stored in the front area of the center console.



Fig. 66 Rear center console: opening the folding table

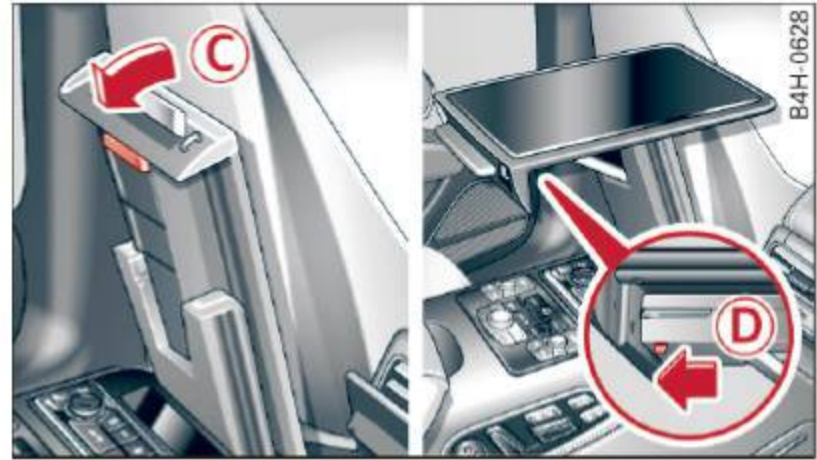

Fig. 67 Rear center console: folding table inclined position

Opening

- ▶ Pull the handle (A) back ⇒ *fig. 66*. The folding table extends out partially by itself ⇒ ⚠.
- ▶ Pull the folding table up until it locks into place (B).
- ▶ Fold the tabletop back and down (C).

Storing

- ▶ Release the tabletop (D) to fold it back.
- ▶ You can now move the folding table vertically back into its original position.

! WARNING

- Do not open the folding table while driving. Opening the folding table while driving increases the risk of injury in the event of a collision or sudden braking.
- To reduce the risk of pinching, open and close the folding table carefully and in a controlled manner.

Luggage compartment

Tie-downs and luggage compartment net

The luggage compartment net prevents small objects from sliding.



Fig. 68 Location of the fastening eyes in the luggage compartment



Fig. 69 Luggage compartment net unhooked

- ▶ To secure objects with the luggage compartment net*, fold the tie-down bracket upward ⇒ *fig. 68*.
- ▶ Insert the hooks on the luggage compartment net* into the tie-downs ⇒ *fig. 69*.
- ▶ Read and heed all WARNINGS ⇒ *page 141, Stowing luggage*.

In a collision, the laws of physics mean that even smaller items that are loose in the vehicle will turn into heavy missiles that can cause serious injury. Items in the vehicle pick up kinetic energy which varies with the vehicle and the weight of the item. Vehicle speed is the most significant factor.

For example, in a frontal collision at a speed of 30 mph (48 km/h), the forces acting on a 10-lb (4.5 kg) object are about 20 times the normal weight of the item. This means that the weight of the item would suddenly be the

equivalent of about 200 lbs (90 kg). One can easily imagine the injuries that an item of that weight flying freely through the passenger compartment can cause in a collision at a speed considered relatively low.

WARNING

Weak, damaged or improper straps used to secure items to tie-downs can fail during hard braking or in a collision and cause serious personal injury.

- Always use suitable retaining straps and properly secure items to the tie-downs in the luggage compartment to help prevent items from shifting or flying forward.
- Never attach a child seat tether strap to a tie-down.
- For strength-related reasons, the mounting hooks can only be used to secure objects weighing up to 10 lb. (5 kg). Heavier objects will not be adequately secured – there is a risk of injury.

Pass-through with ski sack

Preparing the pass-through

Applies to vehicles: with pass-through and ski sack

Long objects such as skis can be transported in the ski sack.



Fig. 70 Rear bench seat: removing the protective cover

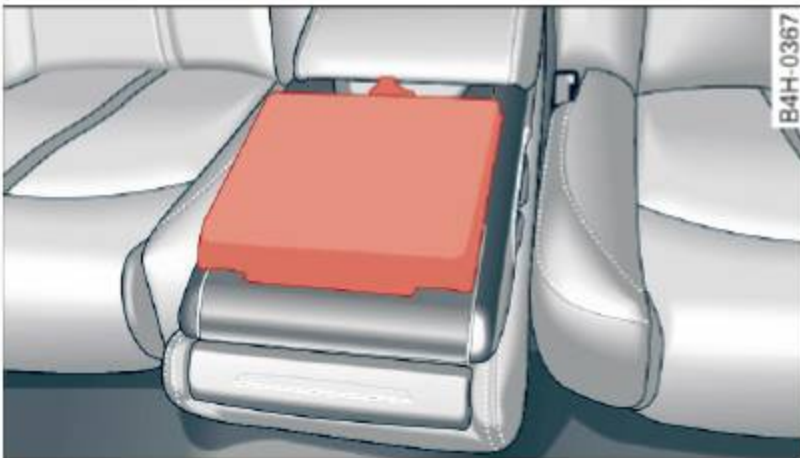

Fig. 71 Rear center armrest: attaching the protective cover

- ▶ Fold the rear center armrest and the cover located behind it down.
- ▶ Press the button to remove the protective cover ⇒ *fig. 70*.
- ▶ To protect the front area of the center armrest, position the cover as illustrated ⇒ *fig. 71* and press the suction cups down so they adhere.
- ▶ Remove the ski sack and unfold it.

Loading and securing the ski sack

Applies to vehicles: with pass-through and ski sack

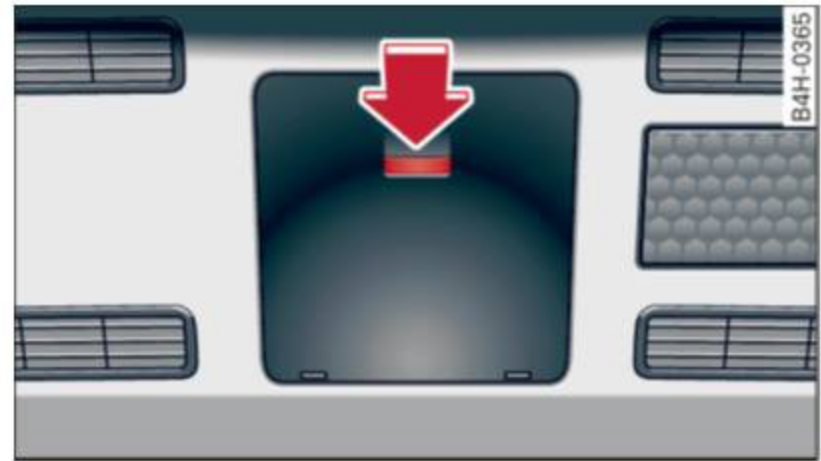

Fig. 72 Luggage compartment: pass-through in the backrest

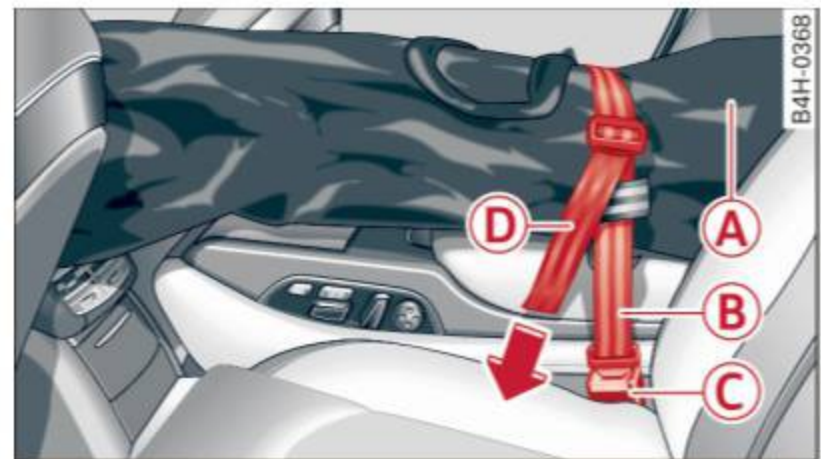

Fig. 73 Rear bench seat: securing the ski sack

Loading

- ▶ Fold the pass-through cover in the luggage compartment down ⇒ *fig. 72*.
- ▶ Slide the pointed end of the skis into the ski sack first ⇒ ⚠. The front part of the bindings must be directly under the securing strap on the ski sack (A) ⇒ *fig. 73*.

Securing

- ▶ Insert the securing strap (B) on the ski sack into the center safety belt latch (C) ⇒ *fig. 73*.
- ▶ Tighten the securing strap (D).

Securing (vehicles with full-length center console)

In the pass-through, two securing straps are in the hooks located in the luggage compartment.

- ▶ Hook the hooks into the front tie-downs in the luggage compartment.
- ▶ Tighten the securing strap (D) in the rear. ▶

WARNING

- The ski sack is intended only for the transportation of skis and other light objects. To reduce the risk of serious personal injury, never transport heavy or pointed objects in the ski sack.
- When braking rapidly or during an accident, the load could be displaced and cause injury to occupants.
- Sharp edges on the load must be covered for protection. Always fasten the belt tightly around the sack and its contents ⇒ *fig. 73*.
- For safety reasons, do not transport more than two pairs of skis in the ski sack.
- You must secure the ski sack with the strap after loading.
- Make sure all objects that you are transporting in the pass-through are secured. Otherwise they could slide around during sudden braking maneuvers and cause injury.

Tips

- Never stow the ski sack away when it is still wet or damp (for example, snow melting from skis). Allow it to dry completely before stowing it away.
- Position skis in the ski sack with the pointed ends facing the front and ski poles with the pointed ends facing the rear.

Roof rack

Description and mounting locations

Additional cargo can be carried with a roof luggage rack.

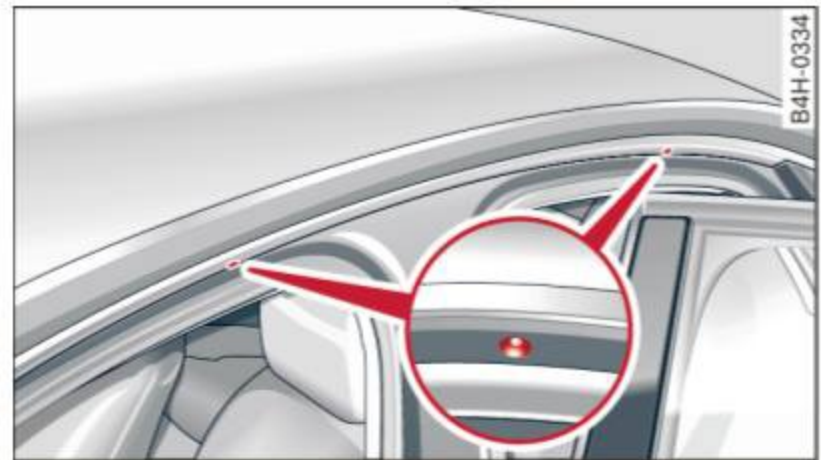

Fig. 74 Roof rack attachment points

- ▶ Always read and follow the instructions provided by the roof rack manufacturer when installing the roof rack system.

If luggage or cargo is to be carried on the roof, you must observe the following:

- To enhance the vehicle's streamlined design, rain gutters have been molded into the roof. It is not possible to use normal roof racks. Only install a roof rack specifically designed for your model A8. Contact the nearest Audi dealer for information on approved modular roof racks for your vehicle.
- Only use roof racks approved for your vehicle. These approved roof racks are the basis for a complete roof rack system. Additional attachments or carrier systems are needed to transport luggage and sports equipment. We recommend using roof racks from the Audi original accessories program.
- When installing the roof rack, make sure it is only mounted on the designated locations on the roof ⇒ *fig. 74*.
- We recommend that you keep the installation instructions for your roof rack system together with your Owner's literature in the vehicle.

When should the roof rack be removed?

- Before going through an automatic car wash (it is best to ask the car wash operator for advice)

- When not in use, to reduce fuel consumption, wind noise and to guard against theft.

WARNING

- Use of an unapproved roof rack or incorrect mounting of an approved roof rack can cause the roof rack or the items attached to it to fall off the roof onto the road.
- Objects falling from the roof of a vehicle can cause a crash and personal injury.
- Only mount the roof rack on the designated locations on the roof ⇒ *fig. 74*.
- The roof rack system must be installed exactly according to the instructions provided.
- When driving with a roof rack system, changes to the center of gravity and wind resistance can change the vehicle handling and lead to a collision. Always adapt your driving and your speed to the current conditions.

Note

- Your vehicle warranty does not cover any damages to the vehicle caused by using roof racks or mounting structures not approved by Audi for your vehicle. The same applies to damage resulting from incorrect roof rack installation.
- Always check the roof rack mountings and hardware before each trip and during a trip to make sure everything is securely tightened. If necessary, retighten the mountings and check the entire system from time to time.
- After mounting a roof rack system, or when you transport objects on the roof of your vehicle, the height of the vehicle is naturally increased. Be careful when driving under low bridges or in parking garages for example. This could cause damage to the load and even the vehicle itself.
- Make sure the open rear lid and the sunroof* do not come into contact with the roof rack.

Loading the roof rack

Always distribute loads evenly. Make sure anything on the roof rack is securely tied down.

- ▶ Always distribute the loads on the roof rack evenly.
- ▶ Always attach items to the roof rack securely before you drive off.

The maximum permissible roof weight is **220 lb (100 kg)**. The roof weight is the total of the weight of the roof rack, the attachments and the cargo you are carrying. You must also not exceed the maximum load weight for the roof rack you are using.

When using a roof rack system which has a lower load carrying capacity, you must not use up the total maximum permissible load carrying capacity specified above. Instead, you should load the roof rack system only to the maximum capacity specified by the manufacturer of the roof rack system.

WARNING

Weak, damaged or improper straps used to secure items to the roof rack can fail during hard braking or in a collision and cause serious personal injury.

- Make sure the roof rack is installed exactly as specified above ⇒ *page 72*.
- Always use suitable mounting straps for securing items to the roof rack to help prevent items from shifting or flying forward.
- Items on the roof rack must always be securely mounted.
- The use of a roof rack can negatively affect the way a vehicle handles. Cargo that is large, heavy, bulky, long or flat will have a greater negative influence on the vehicle's aerodynamics, center of gravity and overall handling. Always drive slowly, avoid sudden braking and maneuvers when transporting cargo on the roof of your vehicle.

- Never exceed the maximum permissible load carrying capacity of the roof of your vehicle, the permissible axle weights and the permissible total weight of your vehicle ⇒ *page 289, Weights*.



For the sake of the environment

As a result of the increased wind resistance created by a roof rack, your vehicle is using fuel unnecessarily. So remove the roof rack after using it.

12-volt sockets

Applies to vehicles: 12-volt sockets

Electrical accessories can be connected to every 12-volt socket.

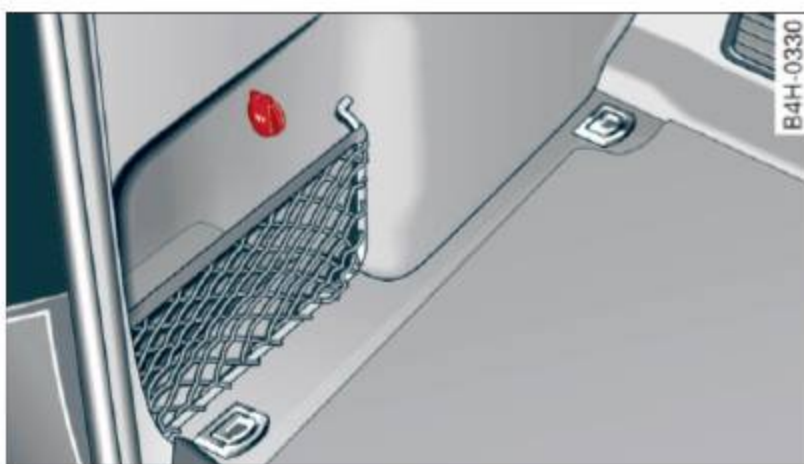

Fig. 75 Section of the trim panel of the luggage compartment: 12-volt socket



Fig. 76 Rear center console: 12-volt socket

- ▶ Open the socket cover ⇒ *fig. 75* or ⇒ *fig. 76*.
- ▶ Insert the plug of the electrical device into the socket.

There is an additional 12 volt socket in the front center console ⇒ *page 75, fig. 77*.

The 12 volt sockets can be used for electrical accessories. The power input must not exceed 120 watts.

Before you purchase any accessories, always read and follow the information in ⇒ *page 294, Additional accessories and parts replacement*.



WARNING

The sockets and the electrical accessories connected to them operate only when the ignition is switched on. Incorrect usage can lead to serious injuries or burns. To reduce the risk of injuries, never leave children unattended in the vehicle with the vehicle key.



Note

To avoid damaging the socket, only use plugs that fit properly.

- Never connect equipment that generates electrical current, such as a solar panel or battery charger, to the 12 volt socket. This could damage the vehicle's electrical system.
- The 12 volt socket should only be used for a short period of time as a power source for electrical equipment. Please use the electrical sockets in the vehicle when connecting equipment for longer periods.



Tips

When the engine is off and accessories are still plugged in and are on, the vehicle battery can still be drained.

Storage

Cupholder



Fig. 77 Center console: front cupholder



Fig. 78 Section of the rear bench seat: rear cupholder

Front cupholder

- ▶ To open the cupholder, tap the cover
⇒ fig. 77, ⇒ ⚠.

Rear cupholder

- ▶ To open the cupholder, tap the front strip
⇒ fig. 78, ⇒ ⚠.

In vehicles with a full-length center console in the rear, the cupholder is located at **B**
⇒ page 68, fig. 65.

⚠ WARNING

Spilled hot liquid can cause an accident and personal injury.

- Never carry any beverage containers with hot liquids, such as hot coffee or hot tea, in the vehicle while it is moving. In case of an accident, sudden braking or other vehicle movement, hot liquid could spill, causing scalding burns. Spilled hot liquid can also cause an accident and personal injury.

- Use only soft cups in the cupholder. Hard cups and glasses can cause injury in an accident.

! Note

Only drink containers with lids should be carried in the cupholder. Liquid could spill out and damage your vehicle's electronic equipment or stain the upholstery, etc.

Cooled glove compartment

The cooled glove compartment only functions when the A/C system is switched on.

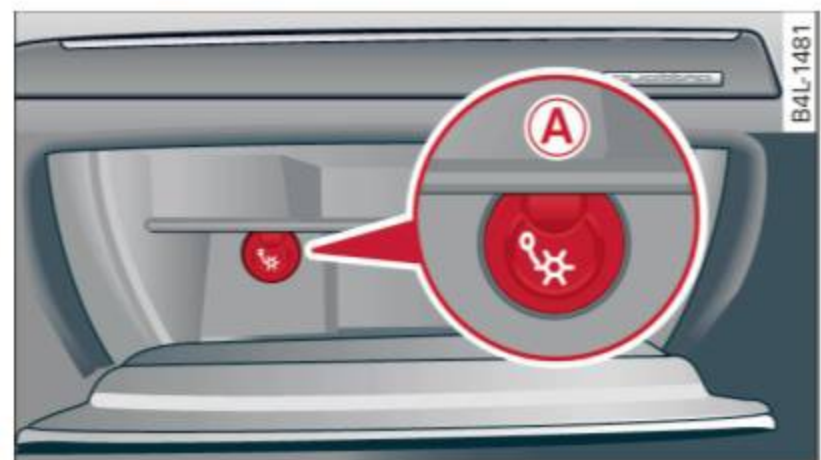

Fig. 79 Glove compartment: switching cooling mode on/off

- ▶ Turn the knob **A** counterclockwise to switch cooling on. The symbols on the knob indicate the correct position ⇒ fig. 79.
- ▶ Turn the knob **A** clockwise to switch cooling off.

The glove compartment cooling mode only functions when the vehicle A/C system is switched on. If the heating is switched on, switching the glove compartment cooling mode off is recommended.

⚠ WARNING

Always leave the lid on the glove compartment cover closed while driving to reduce the risk of injury.

i Tips

The glove compartment can be locked using the mechanical key ⇒ page 32.

Additional storage

There are a variety of storage compartments and fasteners in various places in the vehicle.

- Storage compartments in the doors
- Net in the front passenger footwell
- Eyeglasses compartment in the headliner (near the rearview mirror)
- Storage compartments under the center armrests
- Compartments* on the back of the front seat backrests
- Garment hooks over the rear doors
- Compartment in the center console with pass-through)* (rear)
- Compartment behind the rear center armrest (in vehicles without the pass-through* or cooler*)
- Bag hooks in the luggage compartment



WARNING

- When driving, do not leave any hard objects on the rear window shelf or allow your pet to sit on the shelf. They could become a hazard for vehicle occupants in the event of sudden braking or a crash.
- Always remove objects from the instrument panel. Any items not stored could slide around inside the vehicle while driving or when accelerating or when applying the brakes or when driving around a corner.
- When you are driving make sure that anything you may have placed in the center console or other storage locations cannot fall out into the footwells. In case of sudden braking you would not be able to brake or accelerate.
- Any articles of clothing that you have hung up must not interfere with the driver's view. The coat hooks are designed only for lightweight clothing. Never hang any clothing with hard, pointed or heavy objects in the pockets on the coat hooks. During sudden braking or in an accident - especially if the airbag is deployed -

these objects could injure any passengers inside the vehicle.

- To reduce the risk of personal injury in an accident or sudden stop, always keep the glove compartment closed while driving.
- Read and follow all WARNINGS
⇒ *page 173, Important safety instructions on the side airbag system.*
- Hang clothes in such a way that they do not impair the driver's vision.
- The coat hooks must only be used for lightweight clothing. Do not leave any heavy or sharp edged objects in the pockets which may interfere with the side curtain airbag deployment and can cause personal injury in a crash.
- Do not use coat hangers for hanging clothing on the coat hooks as this can interfere with proper deployment of the side curtain airbags in an accident.
- Do not hang heavy objects on the coat hooks, as they could cause personal injury in a sudden stop.



Note

Objects located on the rear shelf that rub against the rear window could damage the heating wires for the rear window defogger.



Tips

- A vent slot is located between the shelf and the rear window. Do not block the vent with any items you may place on the rear window shelf.
- Do not place bulky items on the rear window shelf as they could restrict or block the driver's vision in the rear view mirror.

Cooler

Introduction

Applies to vehicles: with cooler

Please clean the cooler before using it for the first time ⇒ *table on page 218.*

You can only switch on the cooler if

- the temperature in the luggage compartment is below 131 °F (55 °C). The cooler switches off automatically if the temperature in the luggage compartment exceeds 131 °F (55 °C). Once the temperature falls below 131 °F (55 °C) again, the cooler switches on again automatically.
- the battery is adequately charged. The cooler switches off automatically if the vehicle battery voltage falls below a minimum level. This prevents the battery from discharging. The cooler switches back on again automatically when the battery voltage increases again (e.g. after starting the engine).

The cooler cools to 42.8 °F (+ 6 °C) and the freezer cools to 21.2 °F (- 6 °C) in optimum cooling conditions. The cooling performance is affected by the temperature in the luggage compartment. The temperature inside the cooler will be higher if the luggage compartment is hot.

WARNING

To avoid putting the occupants at any risk, please observe the following safety rules:

- The maximum capacity is 2.5 kg (5.5 lbs.).
- Never overload the cooler. This could cause injury in the event of a collision or sudden braking.
- The cooler lid must always be kept closed while you are driving. Make sure the retaining catch is securely engaged. The contents of the cooler could be thrown forward into the passenger compartment in the event of a collision or under sudden braking - risk of injury!
- Inflammable liquids, gas canisters, etc. must not be stored in the cooler - risk of explosion! This also includes any products that might emit volatile or inflammable gases.
- Liquids will freeze at temperatures at or below 32 °F (0 °C) and may cause glass bottles to burst!

Note

- The ventilation openings for the cooler are located on the back panel trim in the luggage compartment and **must** be kept clear at all times.
- If the cooler is not functioning properly, switch it off to prevent further damage. Have it checked by a qualified workshop.

Operation

Applies to vehicles: with cooler



Fig. 80 Rear center armrest

The cooler is located in the rear cabin behind the center armrest or behind the sliding cover (depending on the equipment fitted in your vehicle). The cooler and freezer only work when the ignition is on.

Opening / closing the cooler

- ▶ To open the cooler, pull the release lever **1** ⇒ *fig. 80*.
- ▶ To close the cooler, push the lid back into its original position. You should hear the release lever **1** engage if the lid is properly closed.

Switching on/off

- ▶ Press button **A** ⇒ *fig. 80* to switch the cooler on/off. The symbol in the button is lit when this function is activated.
- ▶ Press button **B** to switch the freezer on/off. The symbol in the button is lit when this function is activated.

i Tips

- Always try to leave the lid open for as short a time as possible to prevent condensation buildup.
- Do not put hot food or drinks in the cooler.

Warm and cold

Climate controls

Description

The climate control system warms, cools and adds humidity to the air in the vehicle interior. It is the most effective when the windows and sunroof* are closed. If the temperature inside the parked vehicle becomes very warm, opening the window briefly will speed up the cooling process.

In all heating mode functions except *defrost*, the blower only switches to a higher speed once the engine coolant has reached a certain temperature.

Condensation from the cooling system can drip and form a puddle of water under the vehicle. This is normal and does not mean there is a leak.

Pollutant filter

The pollutant filter removes pollutants such as dust and pollen from the air.

The air pollutants filter must be changed at the intervals specified in your Warranty & Maintenance booklet, so that the air conditioner can properly work.

If you drive your vehicle in an area with high air pollution, the filter may need to be changed more frequently than specified in your Audi Warranty & Maintenance booklet. If in doubt, ask your authorized Audi Service Advisor for advice.

Key coded settings

The climate control settings are automatically stored and assigned to the remote control key that is in use.

WARNING

Reduced visibility is dangerous and can cause accidents.

- For safe driving it is very important that all windows be free of ice, snow and condensation.
- Completely familiarize yourself with the proper use and function of the heating and ventilation system and especially how to defog and defrost the windows.
- Never use the windshield wiper/washer system in freezing weather until you have warmed the windshield first, using the heating and ventilation system. The washer solution may freeze on the windshield and reduce visibility.

Note

- If you suspect that the air conditioner has been damaged, switch the system off to avoid further damage and have it inspected by a qualified dealership.
- Repairs to the Audi air conditioner require special technical knowledge and special tools. Contact an authorized Audi dealer for assistance.

For the sake of the environment

By reducing the amount of fuel you use, you also reduce the amount of pollutants emitted into the air.

Tips

- Keep the air intake slots (in front of the windshield) free from ice, snow and debris in order to maintain the proper function of the climate control system.
- The energy management system may switch the seat heating* or rear window defroster off temporarily. These systems are available again as soon as the energy balance has been restored.
- Air escapes through vents under the rear window. When placing items of clothing on the luggage compartment cover, ensure that the openings are not covered.

Operation

We recommend pressing the **AUTO** button and setting the temperature to 72 °F (22 °C).



B4H-0656

Fig. 81 Cockpit controls



B4H-0382

Fig. 82 four zone automatic climate control: rear controls

Press the buttons to turn the functions on or off. Use the dials to adjust the temperature, the blower speed and the air distribution. The LED in a button will light up when the function is switched on. The settings are shown in the climate control display and are also shown in the MMI display for a few seconds. The driver and front passenger settings can be adjusted separately.

You can also adjust the rear left and right sides in the four zone automatic climate control* ⇒ fig. 82.

OFF Switching the climate control system on/off

The **OFF** button switches the climate control system on or off. It also switches on when you turn the dial or press any button. Airflow from

outside is blocked when the climate control system is switched off.

You can activate the residual heat function when the ignition is off by pressing and holding the  button. The residual heat from the coolant is used to heat the vehicle interior. The residual heat function switches off automatically after about 30 minutes.

A/C Switching cooling mode on/off

The air is not cooled and humidity is not removed when cooling mode is switched off. This can cause fog on the windows. Cooling mode switches off automatically when the outside temperature is below zero.

Switching recirculation mode on/off

In recirculation mode, the air inside the vehicle is circulated and filtered. This prevents the unfiltered air outside the vehicle from entering the vehicle interior. We recommend switching recirculation mode on when driving through a tunnel or when sitting in traffic ⇒ .

The **AUTO** button or  button switches recirculation mode off.

AUTO Switching automatic mode on

Automatic mode maintains a constant temperature inside the vehicle. Air temperature, ►

airflow and air distribution are controlled automatically.

Adjusting the temperature

Temperatures between 60 °F (+16 °C) and 84 °F (+28 °C) can be set. Outside of this range, **lo** or **hi** will appear in the climate control system display. At both of these settings, the climate control system runs continuously at maximum cooling or heating power. There is no temperature regulation.

Adjusting the airflow

You can adjust the airflow manually to suit your needs. To have the airflow regulated automatically, press the **AUTO** button.

Adjusting the air distribution

You can manually select the vents where the air will flow. To have the air distribution regulated automatically, press the **AUTO** button.

/ * Adjusting Seat heating/ventilation*

Pressing the button switches the seat heating/ventilation on at the highest setting (level 3). The LEDs indicate the temperature level. To reduce the temperature, press the button again. To switch the seat heating/ventilation off, press the button repeatedly until the LED turns off.

After 10 minutes, the seat heating/ventilation automatically switches from level 3 to level 2.

In vehicles without the four zone automatic climate control*, buttons in the rear center console control the seat heating for both outer rear seats*.

Switch the defroster on/off

The windshield and side windows are defrosted or cleared of condensation as quickly as possible. The maximum amount of air flows mainly from the vents below the windshield. Recirculation mode switches off. The temperature should be set to 72 °F (22 °C) or higher. The temperature is controlled automatically.

The **AUTO** button switches the defroster off.

Switching rear window heater on/off

The rear window heater only operates when the engine is running. It switches off automatically after 10 to 20 minutes, depending on the outside temperature.

To prevent the rear window heater from switching off automatically, press and hold the  button for more than 2 seconds. This remains stored until the ignition is switched off.

SYNC Synchronization*

When synchronization is switched on, the settings for the driver's side are applied to the front passenger's side (except for seat heating/ventilation*). The rear seat is also synchronized in vehicles with the 4-zone deluxe automatic climate control system*. Synchronization switches off if the settings are adjusted on the front passenger's side or in the rear*.

You can synchronize the settings in a row by pressing and holding a knob. For example, to apply the settings for the front passenger's side to the driver's side, press and hold the knob on the front passenger's side.

Air vents

You can open or close the center and rear vents in the cockpit and the vents in the rear center console and door pillars using the ridged thumbwheels. The levers adjust the direction of the airflow from the vents.

WARNING

- Do not use the recirculation mode for extended periods of time. The windows could fog up since no fresh air can enter the vehicle. If the windows fog up, press the air recirculation button again immediately to switch off the air recirculation function or select defrost.
- Individuals with reduced sensitivity to pain or temperature could develop burns when using the seat heating function. To reduce the risk of injury, these individuals should not use seat heating.

! Note

To avoid damage to the heating elements in the seats, do not kneel on the seats or place heavy loads on a small area of the seat.

Setup



The climate control system setup is accessed through the MMI.

- ▶ Select: **CAR** function button > **Car systems** control button > **A/C**.

Rear cabin settings*

When this function is selected, all settings for the rear can be adjusted through the climate control system in the cockpit. The climate control system settings cannot be adjusted in the rear seat at the same time. This function switches off after a certain period of time or when one of the dials in the cockpit is pressed.

Auto recirculation*

The sensitivity level of the automatic recirculation mode can be set at various levels from **off** to **sensitive**. The recirculation mode  is controlled on automatically. You must press the  button if fog forms on the windows.

Footwell temperature

You can adjust the footwell temperature so that it is cooler or warmer.

Windshield heat*

When the defroster  is switched on and the **Auto** setting is selected, the windshield defroster is controlled automatically.

Supplementary heater*

The supplementary heater warms the interior of vehicles with diesel engines* more quickly. The supplementary heater is controlled automatically in the **Auto** setting.

Solar roof*

Parking ventilation is controlled automatically in the **auto** setting.

When the ignition is off, solar-powered parking ventilation may switch on, as long as

- there is sufficient sunlight,
- the outside temperature is not too low,
- the sunroof is closed or tilted and
- **auto** (MMI) is selected.

Steering wheel heating

Applies to vehicles: with heated steering wheel

The steering wheel rim can be heated.

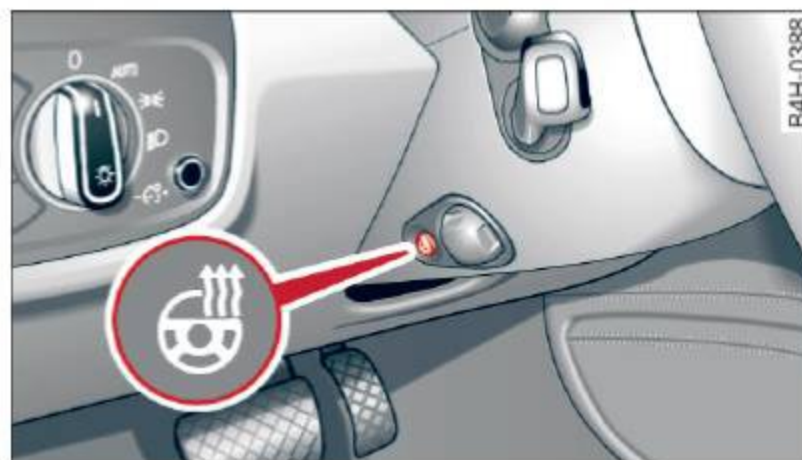



Fig. 83 Steering column: steering wheel heating button

- ▶ Press the  button to switch steering wheel heating on/off. The message **Steering wheel heating on!/Steering wheel heating off!** appears in the instrument cluster display.

The temperature is maintained at a constant level when steering wheel heating is switched on.

The steering wheel heating settings are stored automatically and assigned to the remote control key that is in use.

On the road

Steering

Adjusting steering wheel position

The steering wheel position can be adjusted for height and reach.

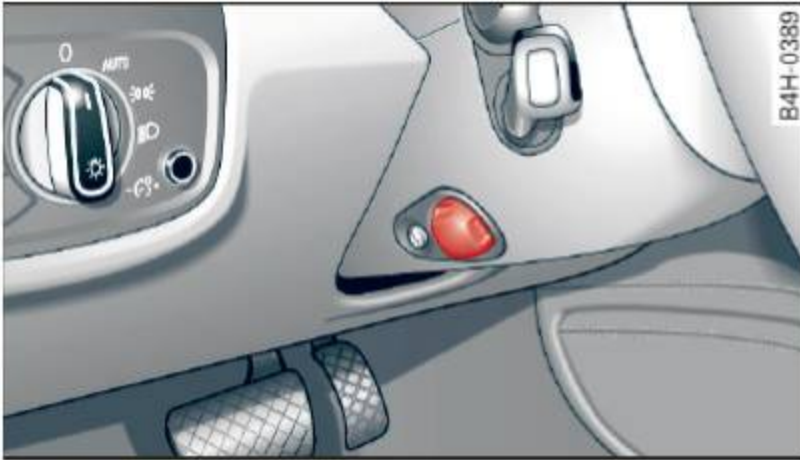

Fig. 84 Switch for steering wheel adjustment

First, adjust the driver's seat correctly.

- ▶ To adjust the height, press the switch up/down. The steering column will continue moving as long as you are pressing the switch.
- ▶ To move the steering wheel forward or back, press the switch forward/back. The steering column will continue moving as long as you are pressing the switch.

There must be at least 10 inches (25 cm) between your chest and the center of the steering wheel. If you cannot sit more than 10 inches (25 cm) from the steering wheel, see if adaptive equipment is available to help you reach the pedals and increase the distance from the steering wheel.

For detailed information on how to adjust the driver's seat, see ⇒ page 59.

In vehicles with the memory function*, the steering column settings are stored together with the seat position.

WARNING

Improper use of steering wheel adjustment and improper seating position can cause serious personal injury.

- Adjust the steering wheel column only when the vehicle is not moving to prevent loss of vehicle control.
- Adjust the driver's seat or steering wheel so that there is a minimum of 10 inches (25 cm) between your chest and the steering wheel ⇒ page 136, fig. 153. If you cannot maintain this minimum distance, the airbag system cannot protect you properly.
- If physical limitations prevent you from sitting 10 inches (25 cm) or more from the steering wheel, check with your authorized Audi dealer to see if adaptive equipment is available.
- If the steering wheel is aligned with your face, the supplemental driver's airbag cannot provide as much protection in an accident. Always make sure that the steering wheel is aligned with your chest.
- Always hold the steering wheel with your hands at the 9 o'clock and 3 o'clock positions to reduce the risk of personal injury if the driver's airbag deploys.
- Never hold the steering wheel at the 12 o'clock position or with your hands inside the steering wheel rim or on the steering wheel hub. Holding the steering wheel the wrong way can cause serious injuries to the hands, arms and head if the driver's airbag deploys.

Easy entry feature

The easy entry feature makes it easier to enter and exit the vehicle by automatically adjusting the steering wheel.

- ▶ Select in the MMI: **CAR** function button > **Car systems** control button > **Vehicle settings** > **Seats** > **Driver's seat** > **Easy entry** > **On**.

When the easy entry feature is turned on, the steering wheel moves up to the park position when you switch off the ignition. After you enter the vehicle, the steering wheel moves to

the stored position as soon as you switch on the ignition.

Starting and stopping the engine

Starting the engine

This button switches on the ignition and starts the engine.





Fig. 85 Center console: START ENGINE STOP button

Switching the ignition on/off

- ▶ To switch the ignition on/off, press the **START ENGINE STOP** button. Do not press the brake pedal while doing this. Diesel vehicles are preheated while the ignition is switched on.

Starting the engine

- ▶ Press the brake pedal ⇒ .
- ▶ Press the **START ENGINE STOP** button ⇒ *fig. 85*. The engine will start.
- ▶ It is possible that there will be a slight delay when starting the engine for diesel vehicles in colder temperatures. Therefore, you must hold the brake pedal down until the engine starts. The indicator lamp  illuminates when the engine is preheated.

If the engine does not start immediately, the starting process is automatically stopped after a short time. Repeat starting procedure.

Start-Stop-System*:

Note the information on ⇒ *page 88, Start-Stop-System*.

WARNING

- Never allow the engine to run in confined spaces - danger of asphyxiation.
- Never turn off the engine until the vehicle has come to a complete stop.
- The brake booster and power steering only work when the engine is running. If the engine is off, you have to use more force when steering or braking. Because you cannot steer and brake as you usually would, this could lead to crashes and serious injuries.

Note

- Avoid high engine rpm, full throttle and heavy engine loads until the engine has reached operating temperature - otherwise you risk engine damage.
- The engine cannot be started by pushing or towing the vehicle.

Tips

- After a cold engine is started, there may be a brief period of increased noise because oil pressure must first build up in the hydraulic valve adjusters. This is normal and not a cause for concern.
- If you leave the vehicle with the ignition switched on, the ignition will switch off after a certain period of time. Please note that electrical equipment such as exterior lights will switch off as well when that happens.

Stopping the engine

- ▶ Bring your vehicle to a complete stop.
- ▶ Move the selector lever to the P or N position.
- ▶ **Press** the **START ENGINE STOP** button ⇒ *page 84, fig. 85*.

When you stop and the Start-Stop-System* turns off the engine, the ignition remains on. Press the **START ENGINE STOP** button to switch the ignition off during a stop phase. ▶

Steering lock

The steering locks when you turn the engine off using the **START ENGINE STOP** button and open the driver's door. The locked steering helps prevent vehicle theft.

Emergency off

If necessary, the engine can be switched off with the selector lever in the R, D or S positions. The engine stops if you press the **START ENGINE STOP** button at speeds below 6 mph (10 km/h).

WARNING

- Never turn off the engine before the vehicle has come to a complete stop. The full function of the brake booster and the power steering is not guaranteed. You must use more force to turn or brake if necessary. Because you cannot steer and brake as you usually would, this could lead to crashes and serious injuries.
- For safety reasons, you should always park your vehicle with the selector lever in P. Otherwise, the vehicle could inadvertently roll away.
- After the engine has been switched off, the radiator fan can continue to run for up to 10 minutes - even with the ignition switched off. It can also switch on again after some time if the coolant temperature rises as the result of a heat buildup or if the engine is hot and the engine compartment is additionally heated by the sun's rays.

Note

Do not stop the engine immediately after hard or extended driving. Keep the engine running for approximately two minutes to prevent excessive heat build-up.

Driver message in the instrument cluster display

Turn off ignition before leaving car

This message appears and a warning tone sounds if you open the driver's door when the ignition is switched on.

Press brake pedal to start engine

This message appears if you press the **START ENGINE STOP** button to start the engine and do not depress the brake pedal. The engine can only be started if the brake pedal is depressed.

Is key in the vehicle?

If the indicator light turns on and the message appears, the remote control key was removed from the vehicle while the engine was running. If the ignition key is not in the vehicle you will not be able to switch on the ignition or restart the engine after it has been switched off. You will also not be able to lock the vehicle from the outside.

Shift to P, otherwise vehicle can roll away. Doors do not lock if lever is not in P.

This driver message appears for safety reasons if the transmission has not been shifted to the P position when you switch the ignition off. Move the selector lever to the P position. Otherwise the vehicle is not protected from rolling and cannot be locked.

Key is not recognized. Hold back of key against marked area. See owner's manual.

If the indicator light turns on and this message appears, there is a malfunction
⇒ *page 86*.

Turn off ignition before leaving car. Battery is discharging

This message appears if the driver's door is opened while the ignition is switched on. Always switch off the ignition if you are leaving the vehicle. See also ⇒ *page 90*.

Shift to P and turn off ignition before leaving car, otherwise vehicle can roll away

This message appears if the driver's door is opened while the ignition is switched on and the selector lever is not in the P position. Shift the selector lever into the P position and

switch off the ignition when you exit the vehicle. Otherwise the vehicle could roll. See also ⇒ page 90.



Starting the engine if there is a malfunction

It may not be possible to start the engine under certain circumstances, for example if the battery in the vehicle key is drained, if interference has affected the key or if there is a system malfunction.



Fig. 86 Center console/master key: starting the engine if there is a malfunction

Requirement: The message **Key not recognized. Hold back of key against marked area. See owner's manual.** must appear and the indicator light  must switch on.

- ▶ Hold the master key vertically in the location indicated  ⇒ fig. 86.
- ▶ Press the brake pedal ⇒  in *Starting the engine on page 84*.
- ▶ Press the **START ENGINE STOP** button. The engine will start.
- ▶ Drive to your authorized Audi dealer immediately to have the malfunction corrected.

Tips

You can view the message again by pressing the **START ENGINE STOP** button.



Electromechanical parking brake

Operation

The electromechanical parking brake replaces the hand brake.



Fig. 87 Center console: Parking brake

- ▶ Pull on the switch  ⇒ fig. 87  to apply the parking brake. The indicator light in the switch illuminates.
- ▶ Step on the brake pedal or the accelerator pedal and press the switch  at the same time to release the parking brake. The indicator light in the switch goes out.

Your vehicle is equipped with an electromechanical parking brake. The parking brake is designed to prevent the vehicle from rolling unintentionally and replaces the hand brake.

In addition to the normal functions of a traditional hand brake, the electromechanical parking brake provides various convenience and safety functions.



When starting from rest

- The integral starting assist helps you when driving by automatically releasing the parking brake ⇒ page 87, *Starting from rest*.
- When starting on inclines, the starting assist prevents the vehicle from unintentionally rolling back. The braking force of the parking brake is not released until sufficient driving force has been built up at the wheels.

Emergency brake function

An emergency brake ensures that the vehicle can be slowed down even if the *normal* brakes fail ⇒ *page 88, Emergency braking*.



Indicator lights



- If the parking brake is closed with the ignition **switched on** the indicator lights come on **PARK** (USA models)/ (Canada models) in the instrument cluster and in the switch.
- If the parking brake is closed with the ignition **switched off** the indicator lights come on **PARK** (USA models)/ (Canada models) in the instrument cluster and in the switch for about 20 seconds.

WARNING

Do not press the accelerator pedal inadvertently if the vehicle is stationary but the engine is running and a gear is selected. Otherwise the vehicle will start to move immediately and could result in a crash.

Note

If the symbol  in the display or the indicator light **BRAKE** (USA models)/ (Canada models) in the instrument cluster flashes, there is a malfunction in the brake system. Please refer to the detailed description of the indicator lights ⇒ *page 14*.



- If the indicator light **PARK** (USA models) /  (Canada models) or  turns on, there may be a malfunction in the parking brake ⇒ *page 15*.

Tips

- You can apply the parking brake at any time - even with the ignition switched off. The ignition must be on and the brake pedal must be pressed in order to release the parking brake.
- Occasional noises when the parking brake is applied and released are normal and are not a cause for concern.
- When the vehicle is parked, the parking brake goes through a self-test cycle at

regular intervals. Any associated noises are normal.

Parking

- ▶ Press the brake pedal to stop the vehicle.
- ▶ Pull the switch  to set the parking brake.
- ▶ Select the P selector lever position ⇒ *page 116*.
- ▶ Turn the engine off ⇒ .
- ▶ When on inclines or declines, turn the steering wheel so that your vehicle will roll into the curb if it begins to move.

WARNING

- When you leave your vehicle - even if only briefly - always take the ignition key with you. This applies particularly when children remain in the vehicle. Otherwise the children could start the engine, release the parking brake or operate electrical equipment (e.g. power windows). There is the risk of an accident.
- When the vehicle is locked, no one - particularly not children should remain in the vehicle. Locked doors make it more difficult for emergency workers to get into the vehicle - putting lives at risk.

Starting from rest

The starting assist function ensures that the parking brake is released automatically upon starting.

Stopping and applying parking brake

- ▶ Pull the switch  to apply the parking brake.

Starting and automatically releasing the parking brake

- ▶ When you start to drive as usual, the parking brake is automatically released and your vehicle begins to move.

When stopping at a traffic signal or stopping in city traffic, the parking brake can be applied. The vehicle does not have to be held

with the footbrake. The parking brake eliminates the tendency to creep with a drive range engaged. As soon as you drive off as usual, the parking brake is released automatically and the vehicle starts to move.

Starting on slopes

When starting on inclines, the starting assist prevents the vehicle from unintentionally rolling back. The braking force of the parking brake is not released until sufficient driving force has been built up at the wheels.

Tips

For safety reasons, the parking brake is released automatically only when the driver's safety belt is engaged in the buckle.

Starting off with a trailer

To prevent rolling back unintentionally on an incline, do the following:

- ▶ Keep the switch (P) pulled and depress the accelerator. The parking brake stays applied and prevents the vehicle from rolling backward.
- ▶ You can release the switch (P) once you are sure that you are developing enough forward momentum at the wheels as you depress the accelerator.

Depending on the weight of the rig (vehicle and trailer) and the severity of the incline, you may roll backwards as you start. You can prevent rolling backwards by holding the parking brake switch (P) pulled out and accelerating - just as you would when starting on a hill with a conventional hand brake.

Emergency braking

In the event that the conventional brake system fails or locks.

- ▶ In an emergency, pull the switch (P) and continue to pull it to slow your vehicle down with the parking brake.
- ▶ As soon as you release the switch (P) or accelerate, the braking process stops.

If you pull the switch (P) and hold it above a speed of about 5 mph (8 km/h), the emergency braking function is initiated. The vehicle is braked at all four wheels by activating the hydraulic brake system. The brake performance is similar to making an emergency stop ⇒ .

In order not to activate the emergency braking by mistake, an audible warning tone (buzzer) sounds when the switch (P) is pulled. As soon as the switch (P) is released, or the accelerator pedal is depressed, emergency braking stops.

WARNING

Emergency braking should only be used in an emergency, when the normal foot brake has failed or the brake pedal is obstructed. Using the parking brake to perform emergency braking will slow your vehicle down as if you had made a full brake application. The laws of physics cannot be suspended even with ESC and its associated components (ABS, ASR, EDL). In corners and when road or weather conditions are bad, a full brake application can cause the vehicle to skid or the rear end to break away - risking an accident.



Start-Stop-System

Description

Applies to vehicles: with Start-Stop-System

The Start-Stop-System can help increase fuel economy and reduce CO₂ emissions.

In the Start-Stop-mode, the engine shuts off automatically when the vehicle is stopped, such as at a traffic light. The ignition remains switched on during this stop phase. The engine will be automatically restarted when needed.

The last Start-Stop-System setting (on/off using the button ) will be restored when the ignition is turned on. The LED in the  button turns on when the Start-Stop-System is switched off manually. ▶

Basic requirements for the Start-Stop mode

- The driver's door is closed.
- The driver's seat belt is latched.
- The hood is closed.
- The vehicle must have been driven faster than 2.5 mph (4 km/h) since the last stop.
- A trailer is not hitched to the vehicle.

WARNING

- Never let the vehicle roll with the engine switched off. You could lose control over the vehicle. This can lead to a collision and serious injuries.
- The brake booster and the steering support do not work while the engine is switched off. More force is required to stop and to steer the vehicle.
- To reduce the risk of injuries, make sure that the Start-Stop-System is turned off when working in the engine compartment ⇒ page 90.

Note

Always switch off the Start-Stop-System when driving through water ⇒ page 90.

Starting/stopping the engine

Applies to vehicles: with Start-Stop-System



Fig. 88 Instrument cluster: engine switched off (stop phase)

- ▶ Slow the vehicle to a stop using the brake and keep pressing the brake pedal. The engine will switch off. The  indicator light appears in the information line in the instrument cluster display.

- ▶ When you take your foot off the brake pedal, the engine restarts. The indicator light turns off.

Additional information

The engine will switch off in the P, D, N and S positions as well as in manual mode. In the P position, the engine will also remain off if you take your foot off the brake pedal. The engine starts again when you select another selector lever position and take your foot off the brake pedal.

If you select the R position during a Stop phase, the engine will start again.

Shift from D to P quickly to prevent the engine from starting unintentionally when shifting through R.

You can determine for yourself if the engine will stop or not by reducing or increasing the amount of force you use to press the brake pedal. For example, if you only lightly press on the brake pedal in stop-and-go traffic or when turning, the engine will not switch off when the vehicle is stationary. As soon as you press the brake down harder, the engine will switch off.

General information

Applies to vehicles: with Start-Stop-System

The standard Start-Stop-mode can be cancelled for different system-related reasons.



Fig. 89 Instrument cluster: engine-Stop temporarily unavailable

Engine will not switch off

Before each stop phase, the system checks if certain conditions have been met. For example, the engine will **not** be switched off in the following situations:

- The engine has not reached the minimum required temperature for Start-Stop-mode.
- The interior temperature selected by the A/C system has not been reached.
- The outside temperature is extremely high/low.
- The windshield is being defrosted
⇒ page 82.
- The parking system* is switched on.
- The battery charge level is too low.
- The steering wheel is sharply turned or there is a steering movement.
- After engaging the reverse gear.
- On sharp inclines.

The  indicator light appears in the information line in the instrument cluster display
⇒ fig. 89.

Engine automatically restarts

The stop phase is interrupted in the following situations, for example. The engine restarts without any action by the driver.

- The interior temperature varies from the temperature selected in the A/C system.
- The windshield is being defrosted
⇒ page 82.
- The brake pedal is pressed several times in a row.
- The battery charge level becomes too low.
- High power consumption.

Switching the ignition automatically

To prevent the battery from draining, the ignition will switch off **automatically** when all of the following conditions have been met:

- The vehicle has already been driven.
- The engine has been turned off by the Start-Stop-System*.
- The driver's door is opened.
- The driver's seat belt is removed.
- The brake pedal is not pressed down.

- The vehicle is stationary.

In this case, the activated low beam will be replaced by the side marker lights. The side marker lights will switch off after approximately 30 minutes or when you lock the vehicle.

If the Start-Stop System has **not** turned off the engine or if you have switched the Start-Stop system off manually, the ignition will **not** be automatically switched off and the engine will continue to run ⇒ .

WARNING

Never allow the engine to run in confined spaces - danger of asphyxiation.

Tips

If you shift into the D, N or S positions after shifting into reverse, the vehicle must be driven faster than 6 mph (10 km/h) in order for the engine to switch off again.

Switching the Start-Stop-System on/off manually

Applies to vehicles: with Start-Stop-System

If you do not wish to use the system, you can switch it off manually.

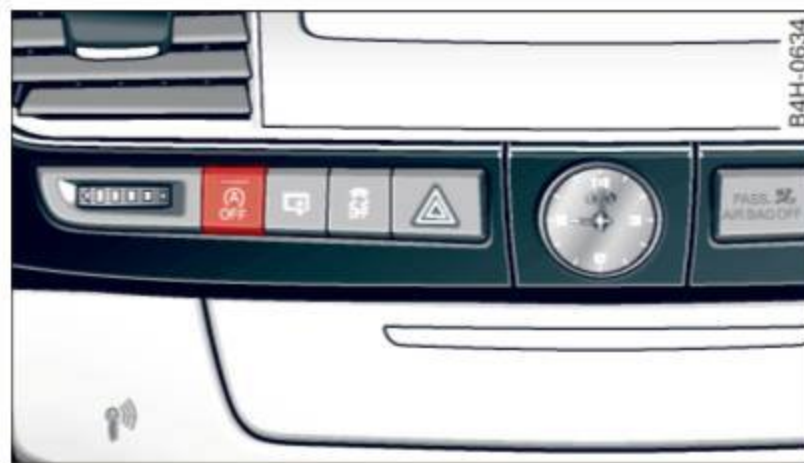



Fig. 90 Center console: Start-Stop-System button

- ▶ To switch the Start-Stop-System off/on manually, press the  button. The LED in the button turns on when the system is switched off. ▶

i Tips

If you switch the system off during a stop phase, the engine will start again automatically.

Messages in the instrument cluster display

Applies to vehicles: with Start-Stop-System

Start-Stop system deactivated: Please restart engine manually

This message appears when specific conditions are not met during a stop phase and the Start-Stop-System will **not** be able to restart the engine. If the D or R selector lever positions were engaged, P will be selected automatically. The engine must be started with the **START ENGINE STOP** button.





Start-Stop system: System fault! Function unavailable

There is a malfunction in the Start-Stop-System. Drive the vehicle to an authorized repair facility for servicing as soon as possible to correct the malfunction.

Speed warning system

Introduction

The speed warning system helps you to stay under a specified maximum speed.

The speed warning system warns you if you are exceeding the maximum speed that you have set. You will hear a warning tone when your speed exceeds the stored value by approximately 3 mph (3 km/h). An indicator light  (USA models)/ (Canada models) in the instrument cluster display also turns on at the same time. The indicator light /  turns off when the speed decreases below the stored maximum speed.

Setting a threshold is recommended if you would like to be reminded when you reach a certain maximum speed. Situations where you may want to do so include driving in a country

with a general speed limit or if there is a specified maximum speed for winter tires.

i Tips

Even though your vehicle is equipped with a speed warning system, you should still watch the speedometer to make sure you are not driving faster than the speed limit.

Setting the threshold

You can set, change and delete the threshold in the MMI.

- ▶ Select: **CAR** function button > **Car systems** control button > **Driver assist** > **Speed warning**.

You can set any threshold between 20 mph (30 km/h) and 150 mph (240 km/h). Settings can each be adjusted in increments of 5 mph (10 km/h).

Cruise control

Switching on

The cruise control system makes it possible to drive at a constant speed starting at 20 mph (30 km/h).



Fig. 91 Control lever with set button



Fig. 92 Display: Selected speed

- ▶ Pull the lever to position ① ⇒ *fig. 91* to switch the system on.
- ▶ Drive at the speed you wish to set.
- ▶ Press button (A) to set that speed.

The stored speed and the indicator light **CRUISE** (US models) /  (Canadian models) appear in the instrument cluster display ⇒ *fig. 92*. The display may vary, depending on the type of display in your vehicle.

The speed is kept constant via an engine output adjustment or active brake intervention.

WARNING

- Always pay attention to traffic even when the cruise control is switched on. You are always responsible for your speed and the distance between your vehicle and other vehicles.
- For safety reasons, the cruise control should not be used in the city, in stop-and-go traffic, on twisting roads and when road conditions are poor (such as ice, fog, gravel, heavy rain and hydroplaning) - risk of accident.
- Turn off the cruise control temporarily when entering turn lanes, highway exit lanes or in construction zones.
- Please note that inadvertently “resting” your foot on the accelerator pedal causes the cruise control not to brake. This is because the cruise control is overridden by the driver's acceleration.
- If a brake system malfunction such as overheating occurs when the cruise control system is switched on, the braking function in the system may be switched off. The other cruise control functions remain active as long as the indicator light **CRUISE** (US models) /  (Canadian models) is on.

Tips

The brake lights illuminate as soon as the brakes decelerate automatically.

Changing speed

- ▶ To increase/decrease the speed in increments, tap the lever in the ⊕/⊖ direction ⇒ *page 91, fig. 91*.
- ▶ To increase/decrease the speed quickly, hold the lever in the ⊕/⊖ direction until the desired speed is displayed.

You can also press the accelerator pedal down to increase your speed, e.g. if you want to pass someone. The speed you saved earlier will resume as soon as you release the accelerator pedal.

If, however, you exceed your saved speed by 6 mph (10 km/h) for longer than 5 minutes, the cruise control will turn off temporarily. The green symbol **CRUISE** (US models) /  in the display is replaced with a white symbol. The saved speed remains the same.

Presetting your speed

You can preset your desired speed while the vehicle is not moving.

- ▶ Switch on the ignition.
- ▶ Pull lever into position ① ⇒ *page 91, fig. 91*.
- ▶ Press the lever in the ⊕ or ⊖ direction to increase or decrease your speed.
- ▶ Release the lever to save that speed.

This function makes it possible, for example, to save the speed you want before driving on the highway. Once on the highway, activate the cruise control by pulling the lever toward ①.

Switching the system off

Temporary deactivation

- ▶ Press the brake pedal, or
- ▶ Press the lever into position ② (not clicked into place) ⇒ *page 91, fig. 91*, or
- ▶ Drive for longer than 5 minutes at more than 5 mph (10 km/h) above the stored speed.

Switching off completely

- ▶ Press lever into position ② (clicked into place), or
- ▶ Switch the ignition off.

The system retains the saved speed if you deactivate the cruise control temporarily. To resume the saved speed, release the brake pedal and pull the lever to position ①.

Switching the ignition off erases the saved speed.



WARNING

You should only return to the saved speed if it is not too fast for the current traffic conditions - risk of an accident!

Audi adaptive cruise control and braking guard

Introduction

Applies to vehicles: with Audi adaptive cruise control

The adaptive cruise control system assists the driver by regulating vehicle speed and helping to maintain a set distance to the vehicle ahead, within the limits of the system. If the system detects a moving vehicle up ahead, adaptive cruise control can brake and then accelerate your vehicle. This helps to make driving more comfortable both on long highway stretches and in stop-and-go traffic.

The braking guard system can warn you about an impending collision and initiate braking maneuvers ⇒ *page 100*.

Adaptive cruise control and braking guard have technical limitations that you must know, so please read this section carefully, understand how the system works and use them properly at all times.

General information

General information

Applies to vehicles: with Audi adaptive cruise control



Fig. 93 Front of the vehicle: sensors and video camera

The areas that contain the radar and ultrasonic sensors and the video camera ⇒ *fig. 93* must never be covered by stickers or other objects or obstructed with dirt, insects, snow or ice that will interfere with the adaptive cruise control system and braking guard. For information on cleaning, refer to ⇒ *page 216*. The

same applies for any modifications made in the front area.

The function of the adaptive cruise control system and braking guard is limited under some conditions:

- Objects can only be detected when they are within sensor range ⇒ *page 96, fig. 96*.
- The system has a limited ability to detect objects that are a short distance ahead, off to the side of your vehicle or moving into your lane.
- Some kinds of vehicles are hard to detect; for example motorcycles, vehicles with high ground clearance or overhanging loads may be detected when it is too late or they may not be detected at all.
- When driving through curves ⇒ *page 95*.
- Stationary objects ⇒ *page 95*.

WARNING

Always pay attention to traffic when adaptive cruise control is switched on and braking guard is active. As the driver, you are still responsible for starting and for maintaining speed and distance to other objects. Braking guard is used to assist you. The driver must always take action to avoid a collision. The driver is always responsible for braking at the correct time.

- Improper use of adaptive cruise control can cause collisions, other accidents and serious personal injury.
- Never let the comfort and convenience that adaptive cruise control and braking guard offer distract you from the need to be alert to traffic conditions and the need to remain in full control of your vehicle at all times,
- Always remember that the adaptive cruise control and braking guard have limits – they will not slow the vehicle down or maintain the set distance when you drive towards an obstacle or something on or near the road that is not moving, such as vehicles stopped in a traffic jam, a stalled or disabled vehicle. If registered by the radar sensors,

vehicles or obstacles that are not moving can trigger a collision warning and if confirmed by the video camera, an acute collision warning.

- For safety reasons, do not use adaptive cruise control when driving on roads with many curves, when the road surface is in poor condition and/or in bad weather (such as ice, fog, gravel, heavy rain and hydroplaning). Using the system under these conditions could result in a collision.
- Switch adaptive cruise control off temporarily when driving in turning lanes, on expressway exits or in construction zones. This prevents the vehicle from accelerating to the set speed when in these situations.
- The adaptive cruise control system will not brake by itself if you put your foot on the accelerator pedal. Doing so can override the speed and distance regulation.
- When approaching stationary objects such as stopped traffic, adaptive cruise control will not respond and braking guard will have limited function.
- The adaptive cruise control system and braking guard do not react to people, animals, objects crossing the road or oncoming objects.
- The function of the radar sensors can be affected by reflective objects such as guard rails, the entrance to a tunnel, heavy rain or ice.
- Never follow a vehicle so closely that you cannot stop your vehicle safely. The adaptive cruise control cannot slow or brake the vehicle safely when you follow another vehicle too closely. Always remember that the automatic braking function cannot bring the vehicle to a sudden or emergency stop under these conditions.
- To prevent unintended operation, always switch ACC off when it is not being used.

! Note

The sensors can be displaced by impacts or damage to the bumper, wheel housing and underbody. That could affect the adaptive cruise control system and braking guard. Have your authorized Audi dealer or authorized Audi Service Facility check their function.

In curves

Applies to vehicles: with Audi adaptive cruise control

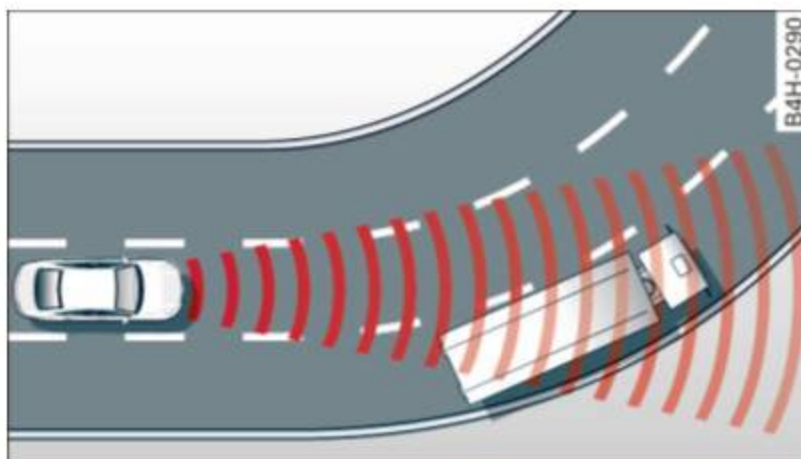

Fig. 94 Example: driving into a curve

When driving into a curve ⇒ *fig. 94* and out of a curve, the adaptive cruise control may react to a vehicle in the next lane and apply the brakes. You can override or prevent the braking by pressing the accelerator pedal briefly.

Stationary objects

Applies to vehicles: with Audi adaptive cruise control

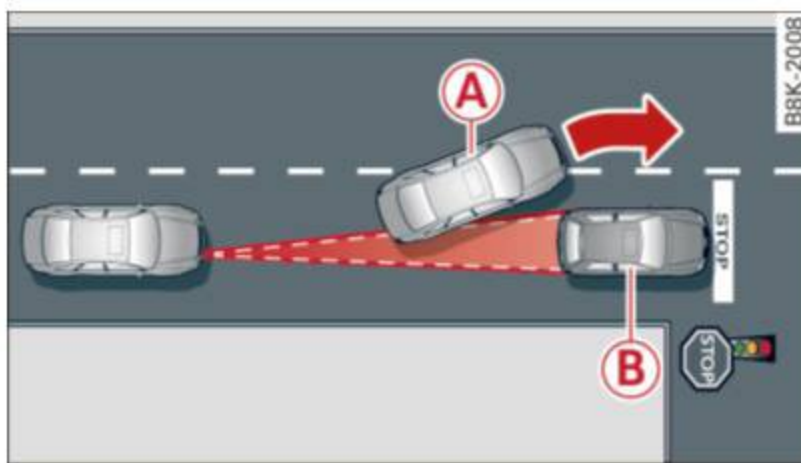

Fig. 95 Example: object changing lanes and stationary object

The adaptive cruise control system only reacts to objects that are moving or that the system has already detected as moving. For example, if a vehicle (A), which has already been detected by the adaptive cruise control, turns or changes lanes and another stationary vehicle

ⓑ is located in front of that vehicle, the system will not react to the stationary vehicle.

Audi adaptive cruise control

Description

Applies to vehicles: with Audi adaptive cruise control

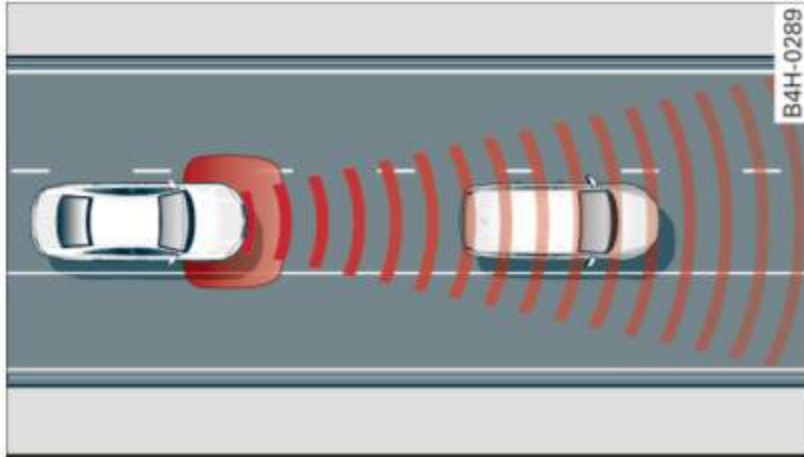

Fig. 96 Detection range

What can adaptive cruise control do?

The adaptive cruise control system uses video, radar and ultrasound. Moving vehicles ahead can be recognized up to about 650 feet (200 m) away.

On open roads with no traffic, adaptive cruise control works like a regular cruise control system. The stored speed is maintained. When approaching a moving vehicle detected up ahead, the adaptive cruise control system automatically slows down to match that vehicle's speed and then maintains the distance that the driver previously stored. As soon as the system does not detect a vehicle up ahead, adaptive cruise control accelerates back up to the stored speed.

In stop-and-go traffic, adaptive cruise control can brake until the vehicle stops and accelerate again under certain conditions and if this is possible within the system's limits and capabilities ⇒ page 98. Adaptive cruise control will not make an emergency stop.

Which functions can be controlled?

When you switch adaptive cruise control on, you can set the current speed as the "control speed" ⇒ page 96, *Switching on and off*.

When driving, you can stop cruise control ⇒ page 98 or change the speed ⇒ page 97 at any time.

You can also set the distance to the object ahead and set the adaptive cruise control driving program ⇒ page 98.

Switching on and off

Applies to vehicles: with Audi adaptive cruise control

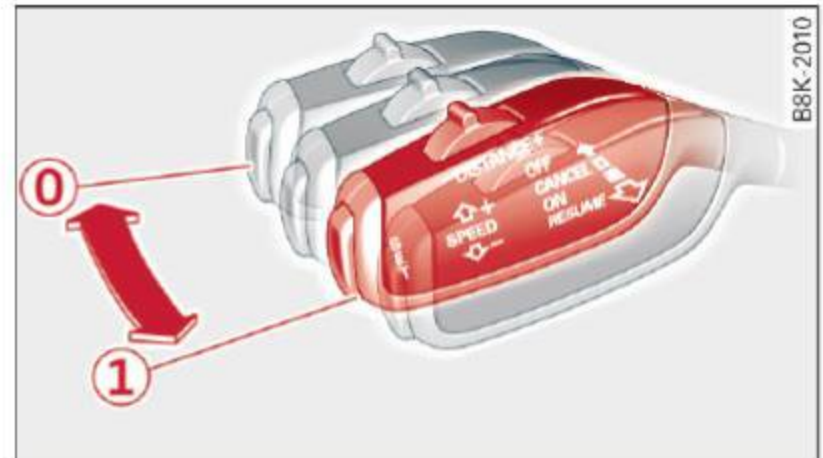

Fig. 97 Selector lever: switching on/off



Fig. 98 Instrument cluster: adaptive cruise control

You can set any speed between 20 mph and 95 mph (30 and 150 km/h).

Indicator lamps and messages in the instrument cluster display inform you about the current system status and settings.

Switching adaptive cruise control on

- ▶ Pull the lever toward you into position ① ⇒ fig. 97. **ACC standby** appears in the instrument cluster display.

Setting the speed and activating regulation

- ▶ To set the current speed, press the **SET** button ⇒ fig. 97. The set speed is shown in the tachometer (A) and is also shown briefly in the display (D) ⇒ fig. 98.

- ▶ You must also press the brake pedal when the vehicle is stopped.

Switching adaptive cruise control off

- ▶ Push the lever away from you into position **(O)** until it clicks into place. The message **ACC off** appears.

(B) Indicator lights

(D) - Adaptive cruise control is switched on. No vehicles are detected up ahead. The stored speed is maintained.

(D) - A moving vehicle is detected up ahead. The adaptive cruise control system regulates the speed and distance to the moving vehicle ahead and accelerates/brakes automatically.

(D) - Adaptive cruise control is switched on. A moving vehicle up ahead was detected. Your vehicle remains stopped.

(D) - When automatic braking is not able to keep enough distance to a previously detected moving vehicle up ahead, you must take control and brake ⇒ *page 99, Prompt for driver intervention.*

(C) Display

If adaptive cruise control is not shown in the display, you can call it up with the multifunction steering wheel buttons ⇒ *page 24.*

Based on the symbols in the display, you can determine if the system is maintaining a distance to the vehicle ahead and what that distance is.

No vehicle - No vehicle ahead was detected.

White vehicle - A vehicle ahead was detected.

Red vehicle - Prompt for the driver to take action ⇒ *page 99.*

Both **arrows** on the **scale (C)** indicate the distance to the vehicle ahead. No arrow appears when the vehicle is on an open road and there is no object ahead. If an object is detected ahead, the arrow moves on the scale.

The green zone on the scale shows the stored distance. For information on changing the

stored distance, refer to ⇒ *page 98.* If the distance selected is too close or may soon become too close, the arrows move into the red zone on the scale.

! WARNING

Improper use of the adaptive cruise control can cause collisions, other accidents and serious personal injuries.

- Pressing the **[SET]** button when driving at speeds below 20 mph (30 km/h), will automatically accelerate the vehicle to 20 mph (30 km/h), which is the minimum speed that can be set.

i Tips

- If you switch the ignition or the adaptive cruise control off, the set speed is erased from the system memory.
- You cannot switch the Electronic Stabilization Control (ESC) to the SPORT mode when adaptive cruise control is switched on.

Changing the speed

Applies to vehicles: with Audi adaptive cruise control



Fig. 99 Selector lever: changing the speed

- ▶ To increase or reduce the speed in increments, **tap** the lever up or down.
- ▶ To increase or reduce the speed quickly, **hold** the lever up or down until the red LED **(A)** reaches the desired speed ⇒ *page 96, fig. 98.*

Following any changes, the new stored speed will be displayed briefly in the display **(D)** ⇒ *page 96, fig. 98.*

Driving in stop-and-go traffic

Applies to vehicles: with Audi adaptive cruise control

The adaptive cruise control system also assists you in stop-and-go traffic. If a previous detected vehicle ahead stops, your vehicle will brake to a stop, within the limits of the system.

- ▶ To resume driving with adaptive cruise control, tap the accelerator pedal or
- ▶ Pull the lever toward you into position ② ⇒ page 98, fig. 100.

i Tips

- If adaptive cruise control is active and your vehicle does not start driving as expected after pulling the lever once, you can start out again by tapping the accelerator pedal.
- If an obstacle is detected when your vehicle starts driving, the system will prompt you to take over ⇒ page 99. Your vehicle will drive more slowly when starting. This may also happen in some situations when no obstacle is apparent.

Interrupting cruise control

Applies to vehicles: with Audi adaptive cruise control

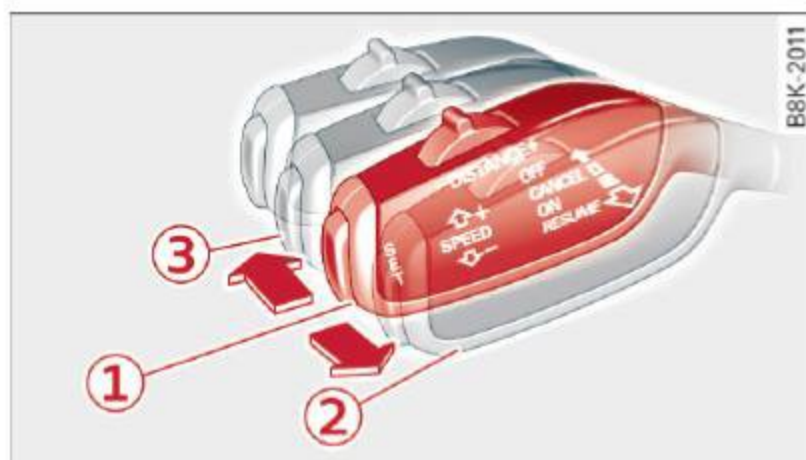

Fig. 100 Selector lever

Requirement: adaptive cruise control must be switched on.

Overriding cruise control

- ▶ To accelerate manually, pull the lever toward you into position ② and hold it there. The message **ACC override** appears. Or
- ▶ press the accelerator pedal.

- ▶ To resume cruise control, release the lever or take your foot off the accelerator pedal.

Canceling cruise control while driving

- ▶ Move the lever into position ③. The message **ACC standby** appears. Or
- ▶ press the brake pedal.
- ▶ To resume the stored speed, move the lever into position ②.

Canceling cruise control when stopped

- ▶ Push the lever away from you into position ③. The message **ACC standby** appears.
- ▶ To resume cruise control, press the brake pedal and pull the lever toward you into position ②.

! WARNING

Never resume the stored speed if the speed is too high for prevailing road, traffic or weather conditions.

Setting the distance

Applies to vehicles: with Audi adaptive cruise control



Fig. 101 Selector lever: setting the distance

- ▶ Tap the switch to display the current set distance ⇒ fig. 101.
- ▶ To increase or reduce the distance by increments, tap the switch again to the left or right. The distance between the two vehicles will change in the instrument cluster display.

When approaching a moving vehicle up ahead, the adaptive cruise control system automatically brakes to match that object's speed and ▶

then maintains the stored distance. If the vehicle ahead accelerates, adaptive cruise control will also accelerate up to the stored speed.

The higher the speed, the greater the distance in yards (meters) ⇒ . The **Distance 3** setting is recommended.

The distances provided are specified values. Depending on the driving situation and the how the vehicle ahead is driving, the actual distance may be more or less than these target distances.

The various symbols for the time increments appear briefly in the information line ⇒ *page 96, fig. 98* when you change the settings.

Distance 1: This setting corresponds to a distance of 92 feet/28 meters when traveling at 62 mph (100 km/h), or a time interval of 1 second.

Distance 2: This setting corresponds to a distance of 118 feet/36 meters when traveling at 62 mph (100 km/h), or a time interval of 1.3 seconds.

Distance 3: This setting corresponds to a distance of 164 feet/50 meters when traveling at 62 mph (100 km/h), or a time interval of 1.8 seconds.

Distance 4: This setting corresponds to a distance of 210 feet/64 meters when traveling at 62 mph (100 km/h), or a time interval of 2.3 seconds.

WARNING

Following other vehicles too closely increases the risk of collisions and serious personal injury.

- Setting short distances to the traffic ahead reduces the time and distance available to bring your vehicle to a safe stop and makes it even more necessary to pay close attention to traffic.
- Always obey applicable traffic laws, use good judgment, and select a safe follow-

ing distance for the traffic, road and weather conditions.

Tips

- **Distance 3** is set automatically each time you switch the ignition on.
- Your standard settings are automatically stored and assigned to the remote control key being used.

Selecting the driving mode

Applies to vehicles: with Audi adaptive cruise control

- ▶ Select the desired driving mode in drive select ⇒ *page 110*.

Tips

Your settings are automatically stored and assigned to the remote control key being used.

Prompt for driver intervention

Applies to vehicles: with Audi adaptive cruise control



Fig. 102 Instrument cluster: request for driver intervention

In certain situations, the system will prompt you to take action. This could happen, for example, if braking by the adaptive cruise control system is not enough to maintain enough distance to the vehicle ahead.

The indicator light and the symbol in the display will warn you about the situation ⇒ *fig. 102*. You will also hear an acoustic signal.

- Press the brake pedal to slow your vehicle down.

Audi braking guard

Description

Applies to vehicles: with Audi adaptive cruise control





Fig. 103 Instrument cluster: approach warning

Braking guard uses radar sensors and a video camera. It also functions within the limits of the system when adaptive cruise control is switched off.

What can braking guard do?

When detected in time, the system can assess situations when a vehicle ahead brakes suddenly or if your own vehicle is traveling at a high speed and approaching a vehicle up ahead that is moving more slowly. Braking guard does not react if it cannot detect the situation.

The system advises you of various situations:

- The **distance warning** is given if you are too close to the vehicle ahead for a long time. If the vehicle ahead brakes sharply, you will not be able to avoid a collision. The indicator light  in the display comes on.
- The **approach warning** is given when a detected vehicle up ahead in your lane is moving much more slowly than you are or if it brakes sharply. When this warning is given, it may only be possible to avoid a collision by swerving or braking sharply. The indicator light  and indicator in the display will warn you about the danger ⇒ *fig. 103*. You will also hear an acoustic signal.

If you do not react fast enough or do not react at all to the situation, braking guard will inter-

vene by braking and the message **braking guard intervention** will appear.

- If a collision is imminent, the system will first provide an **acute warning** by briefly and sharply applying the brakes.
- If you do not react to the acute warning, braking guard can brake with increasing force within the limits of the system. This reduces the vehicle speed in the event of a collision.
- The system can initiate maximum braking shortly before a collision¹⁾. Full deceleration at high speeds occurs only in vehicles with adaptive cruise control and side assist (pre sense plus).
- If the braking guard senses that you are not braking hard enough when a collision is imminent, it can increase the braking force.
- The pre sense functions also engage when a collision is imminent ⇒ *page 197*.

Which functions can be controlled?

You can switch braking guard and the distance/approach warning on or off in the MMI ⇒ *page 101, Settings in the MMI*.

WARNING

Lack of attention can cause collisions, other accidents and serious personal injuries. The braking guard is an assist system and cannot prevent a collision by itself. The driver must always intervene. The driver is always responsible for braking at the correct time.

- Always pay close attention to traffic, even when the braking guard is switched on. Be ready to intervene and be ready to take complete control whenever necessary. Always keep the safe and legal distance between your vehicle and vehicles up ahead.
- Braking guard works within limits and will not respond outside the system limits, for example when approaching a stopped vehicle or stationary obstacle

¹⁾ This is not available in some countries.

(end of a traffic jam or vehicle that has broken down in traffic).

- Always remember that the radar sensor for the braking guard works only within defined detection and range limits that may prevent the proper detection of other vehicles.
- The radar sensor's function and range can be reduced by rain, snow and heavy spray. Moving vehicles up ahead may not be promptly detected or may not be detected at all.
- Reflective surfaces including crash barriers or tunnel entrances may impair the function of the radar sensor.

Tips

- You can cancel the braking with increasing force that is initiated by the system by braking yourself, by accelerating noticeably or by swerving.
- Braking guard error messages ⇒ *page 101*.
- Keep in mind that braking guard can brake unexpectedly. Always secure any cargo or objects that you are transporting to reduce the risk of damage or injury.

Settings in the MMI

Applies to vehicles: with Audi adaptive cruise control

- ▶ Select: **CAR** function button > **Car systems** control button > **Driver assist** > **Audi braking guard**.

System - Switch braking guard **On** and **Off**. When you switch the ignition on, the message **Audi braking guard off** appears if the system is switched off.

Early warning - The distance and approach warnings in the display can be switched **On/Off**.

Tips

- Your settings are automatically stored and assigned to the remote control key

being used at the time the settings are made.

- If you restrict the ESC, the braking guard also switches itself off ⇒ *page 201*.
- Switch braking guard off when you are loading the vehicle onto a vehicle carrier, train, ship or other type of transportation. This can prevent undesired warnings from the braking guard system.

Messages

Applies to vehicles: with Audi adaptive cruise control

Braking guard: off

This driver message appears if the system is turned off via the infotainment. Otherwise, if the system is turned off, the information appears every time shortly after the start of the trip.

The driver message also appears if the system is not available due to a malfunction or if the ESC is not switched on ⇒ *page 201*. If this is the case, the system will not provide warnings about a possible collision.

Braking guard: activated

This driver message appears if sharp brake pressure was applied due to an acute warning.

ACC: Unavailable!

ACC and Audi braking guard: not available

The system cannot detect moving vehicles up ahead correctly and is switched off. The sensors have been displaced or are not working properly. The Audi pre sense functions may also be affected. Drive to your authorized Audi dealer or authorized Audi service facility immediately to have the malfunction corrected.

ACC: currently unavailable. No sensor vision

ACC and braking guide: currently unavailable. No sensor vision

This message appears if the sensor view is obstructed, for example by leaves, snow, heavy spray or dirt. Clean the sensors ⇒ *page 94, fig. 93*.

ACC: Currently unavailable. Gradient too steep

The road exceeds the maximum possible angle for proper adaptive cruise control operation. Adaptive cruise control is switched off.

ACC: Only available in D, S or M

Select the D/S or M selector lever position.

ACC: currently unavailable. Parking brake applied

The adaptive cruise control system switches off automatically if the parking brake is set.

ACC: Currently unavailable. Stability control (ESC) input.

This message appears if the Electronic Stabilization Control (ESC) is working to help stabilize the vehicle. In this case, adaptive cruise control switches off automatically.

ACC off: Manual control!

This message appears when adaptive cruise control cannot set the parking brake. Press the brake pedal to prevent the vehicle from rolling.

•••

Three white dots appear if a setting cannot be selected with the selector lever. For example, this happens if adaptive cruise control cannot resume driving in stop-and-go traffic because one of the conditions required for ACC to work is not present.

Door open

The adaptive cruise control system cannot switch on when a door is open.

Stationary object ahead

This message appears if you would like to switch adaptive cruise control on and there is a stationary vehicle or obstacle directly ahead of your vehicle.

Audi lane assist

Lane assist

Description

Applies to vehicles: with lane assist

Lane assist helps you keep your vehicle in your lane.

Lane assist detects lane marker lines within the limits of the system using a camera in the windshield. If you are approaching a detected lane marker line and it appears likely that you will leave the lane, the system will warn you with a light vibration. Lane assist is operable when the line marking the lane is detected on at least one side of the vehicle.

The system will not warn you before crossing a lane marker line if you have activated the turn signal. In this case, it assumes that you are changing lanes intentionally.

The system is designed for driving on free-ways and expanded highways and thus works only at speeds of 40 mph (65 km/h) or more.

WARNING

- Lane assist will not keep your vehicle in your lane. The system only warns the driver when the vehicle is leaving the lane. The driver is always responsible for keeping the vehicle in the lane.
- The camera is not able to detect all lane boundary lines and in some cases might also detect lane structures or objects as boundary lines. This can lead to incorrect warnings or warnings that fail to go off at all.
- The camera's visibility can be impaired by vehicles ahead of you, for instance, or by rain, snow, heavy spray or light shining into the camera lens. This can cause lane assist to fail to detect boundary lines.

Activating and deactivating

Applies to vehicles: with lane assist

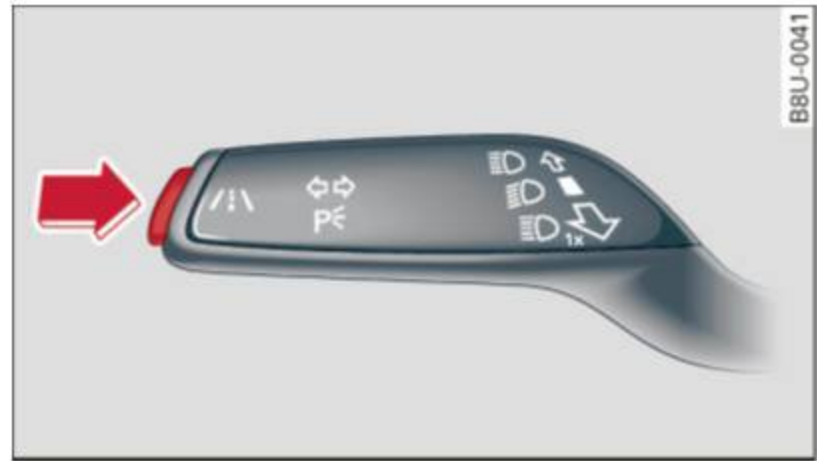

Fig. 104 Turn signal lever: Lane assist button

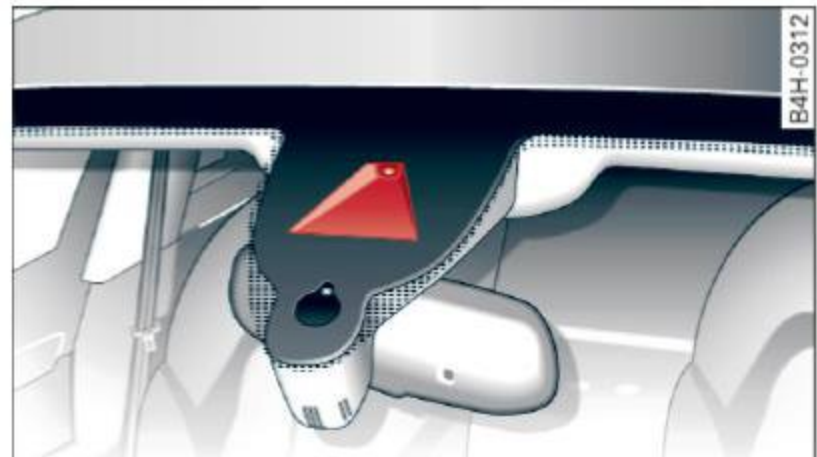







Fig. 105 Windshield: Lane assist camera viewing window

- ▶ Press the  *fig. 104* button to activate or deactivate the system. The  or  indicator light in the instrument cluster will illuminate or go out.

Instrument cluster indicator light

 **Ready:** The green indicator light shows that the system is ready to use. The system can now warn you if you are about to cross a known lane marker line.

 **Not ready:** The yellow indicator light shows that the system is turned on but unable to send a warning. This can be due to the following:

- There is no lane boundary line.
- The relevant lane marker lines are not detected (for example, markings in a construction zone or because they are obstructed by snow, dirt, water or backlighting).
- The vehicle's speed is below the speed needed to activate it, which is about 40 mph (65 km/h).
- The lane is narrower than about 8 ft. (2.5 m).

– The curve is too sharp.

i Tips

Make sure the camera's field of view ⇒ *fig. 105* is not obstructed by stickers, deposits or anything else. For information on cleaning, refer to ⇒ *page 216*.

Lane assist display in the instrument cluster

Applies to vehicles: with lane assist



Fig. 106 Instrument cluster: lane assist is switched on and is warning



Fig. 107 Instrument cluster: lane assist is switched on but not ready to provide warnings

You can call up the lane assist display using the buttons in the multifunction steering wheel ⇒ *page 24*.

When lane assist is switched on, the system indicates which lines are detected by displaying solid lines on the left and/or right side of your vehicle:

White line(s)	Lane assist is switched on and ready to provide warnings on the side that is indicated ⇒ <i>fig. 106</i> .
Red line (left or right)	Lane assist is warning you that you are about to leave your lane ⇒ <i>fig. 106</i> .
Gray line(s)	Lane assist is switched on but is not ready to provide warnings ⇒ <i>fig. 107</i> .

Messages in the instrument cluster display

When the lane assist turns off automatically, the instrument cluster indicator goes out and one of the following messages appears on the display:

Audi lane assist: currently unavailable. No camera view

This message appears if the camera is no longer functional after the system has continuously failed to detect the lane markings. This could happen if:

- The camera field of view ⇒ *page 103, fig. 105* is dirty or covered in ice. Clean the area on the windshield.
- The camera field of view is fogged over. Wait until the fog has cleared before switching lane assist on.
- The system has been unable to detect the lanes for an extended period of time due to road conditions such as lanes covered in snow. Switch lane assist back on when the lines are more visible.

Audi lane assist: Currently unavailable

A temporary malfunction is preventing lane assist from operating. Try switching lane assist on again later.

Audi lane assist: System fault!

Drive to your authorized Audi dealer soon to have the malfunction corrected.

Setting the warning point and steering wheel vibration

Applies to vehicles: with lane assist

You can adjust individual settings in the MMI.

- ▶ Select: **CAR** function button > **Car systems** control button > **Driver assist** > **Audi lane assist**.

Setting the warning point

Early: With this setting, a warning is provided before a wheel touches the detected lane boundary line. The warning depends on the angle in which the vehicle is approaching the line. The distance at which the warning is given increases as the angle becomes sharper. If you drive toward a boundary line at a very sharp angle, the warning will come just before a wheel touches the line.

Medium: With this setting, the warning point is adapted to the course of the road, the lane width and the speed. You will still be warned if you cross slightly over a dotted line when driving on curves.

Late: This setting has the same properties as **medium**. You will only be warned once a wheel crosses a detected line.

Setting the steering wheel vibration

The steering wheel vibration can be set to **Low**, **Medium** or **Strong**. Selecting each of the settings will cause the steering wheel to vibrate so you can check the strength of the vibration in that setting.

Tips

Your settings are automatically stored and assigned to the remote control key being used.

Audi side assist

Lane Change Assistant

Description

Applies to vehicles: with side assist

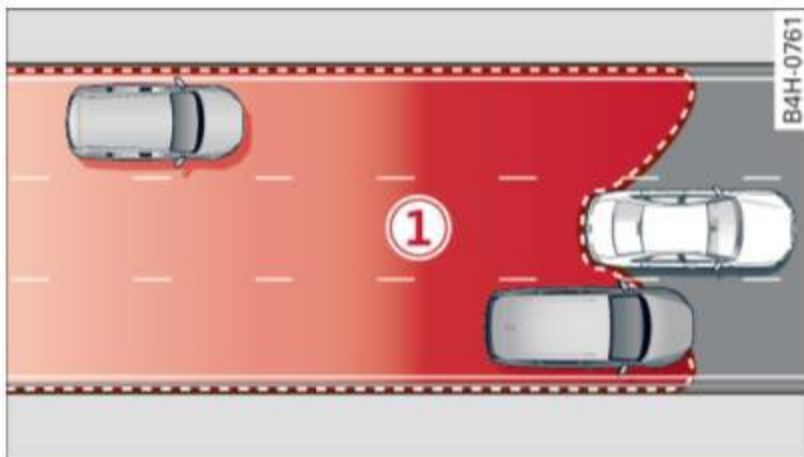

Fig. 108 Sensor detection range

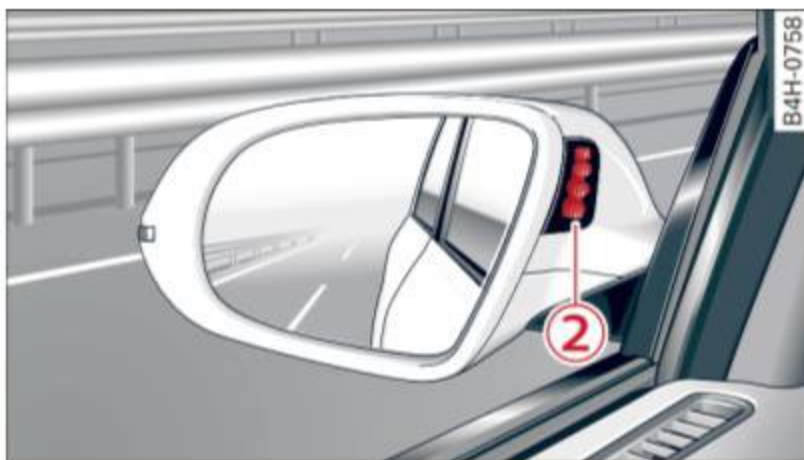

Fig. 109 Display on the exterior mirror

Side assist helps you monitor your blind spot and traffic behind your vehicle. Within the limits of the system, it warns you about vehicles that are coming closer or that are traveling with you within sensor range ① ⇒ *fig. 108*: if a lane change is classified as critical, the display ② in the exterior mirror ⇒ *fig. 109* turns on.

The display in the left exterior mirror provides assistance when making a lane change to the left, while the display in the right exterior mirror provides assistance when making a lane change to the right.

Information stage

As long as you do not activate the turn signal, side assist *informs* you about vehicles that are detected and classified as critical. The display in the respective mirror turns on, but is dim.

The display remains dim intentionally in the information stage so that your view toward the front is not disturbed.

Warning stage

If you activate the turn signal, side assist *warns* you about vehicles that are detected and classified as critical. The display in the respective mirror blinks brightly. If this happens, check traffic by glancing in the rearview mirror and over your shoulder ⇒ ⚠ in *General information on page 107*.

i Tips

- You can adjust the brightness of the display ② ⇒ *page 108*.
- Please refer to the instructions for towing a trailer located in ⇒ *page 107*.

General information

Applies to vehicles: with side assist

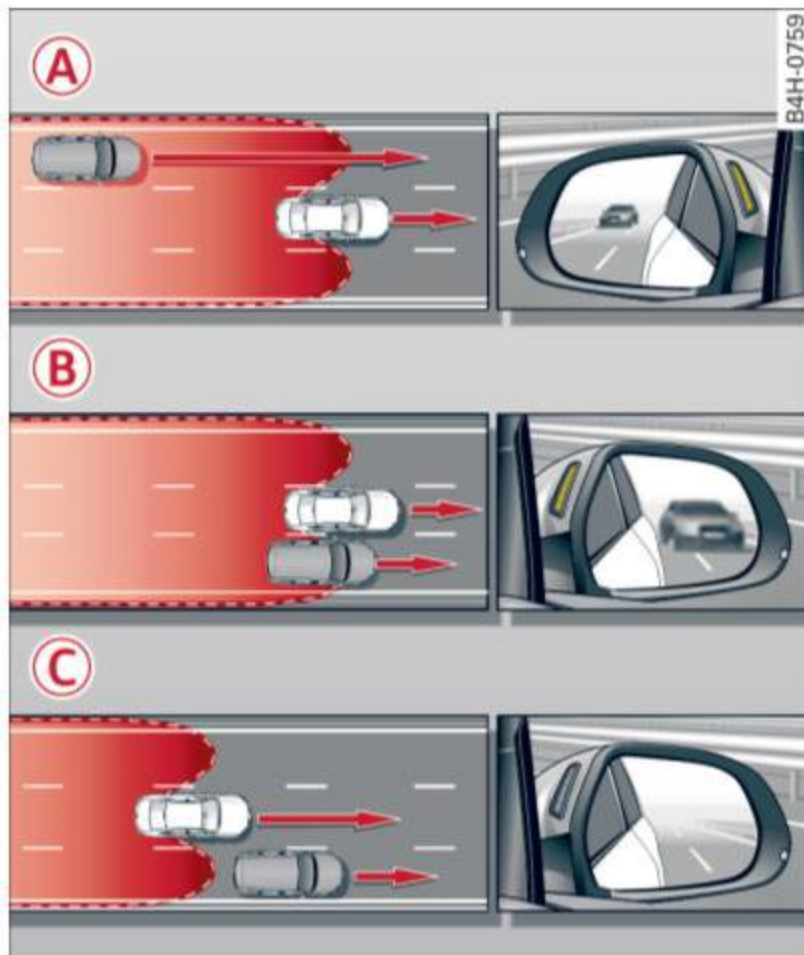

Fig. 110 Driving situations



Fig. 111 Rear of the vehicle: position of the sensors

Side assist functions at speeds above approximately 19 mph (30 km/h).

(A) Vehicles that are approaching

In certain cases, a vehicle will be classified as critical for a lane change even if it is still somewhat far away. The faster a vehicle approaches, the sooner the display in the exterior mirror will turn on.

(B) Vehicles traveling with you

Vehicles traveling with you are indicated in the exterior mirror if they are classified as critical for a lane change. All vehicles detected by side assist are indicated by the time they enter your “blind spot”, at the latest.

(C) Vehicles left behind

If you slowly pass a vehicle that side assist has detected (the difference in speed between the vehicle and your vehicle is less than 9 mph or 15 km/h), the display in the exterior mirror turns on as soon as the vehicle enters your blind spot.

The display will not turn on if you quickly pass a vehicle that side assist has detected (the difference in speed between the vehicle and your vehicle is greater than 9 mph or 15 km/h).

Functional limitations

The radar sensors are designed to detect the left and right adjacent lanes when the road lanes are the normal width. In certain situations, the display in the exterior mirror may turn on even though there is no vehicle located in the area that is critical for a lane change. For example:

- if the lanes are narrow or if you are driving on the edge of your lane. If this is the case, the system may have detected the vehicle in another lane that is *not* adjacent to your current lane.
- if you are driving through a curve. Side assist may react to a vehicle that is one lane over from the adjacent lane.
- if side assist reacts to other objects (such as high or displaced guard rails).
- In poor weather conditions. The side assist functions are limited.

Do not cover the radar sensors ⇒ *fig. 111* with stickers, deposits, bicycle wheels or other objects, because this will affect the function. Do not use side assist when towing a trailer. For information on cleaning, refer to ⇒ *page 216*.

WARNING

- Always pay attention to traffic and to the area around your vehicle. Side assist cannot replace a driver's attention. The driver alone is always responsible for lane changes and similar driving maneuvers.

- Improper reliance on the side assist system can cause collisions and serious personal injury:
 - Never rely only on side assist when changing lanes.
 - Always check rear view mirrors to make sure that it is safe to change lanes.
- Side assist cannot detect all vehicles under all conditions- danger of accident!
- Please note that side assist indicates there are approaching vehicles, or vehicles in your blind spot, only after your vehicle has reached a driving speed of at least 19 mph (30 km/h).
- In certain situations, the system may not function or its function may be limited. For example:
 - if vehicles are approaching or being left behind very quickly. The display may not turn on in time.
 - in poor weather conditions such as heavy rain, snow or heavy mist.
 - on very wide lanes, in tight curves or if there is a rise in the road surface. Vehicles in the adjacent lane may not be detected because they are outside of the sensor range.

Note

The sensors can be displaced by impacts or damage to the bumper, wheel housing and underbody. This can affect the system. Have your authorized Audi dealer or authorized Audi Service Facility check their function.

Tips

- If the window glass in the driver's door or front passenger's door has been tinted, the display in the exterior mirror may be misinterpreted.
- For Declaration of Compliance to United States FCC and Industry Canada regulations ⇒ *page 295*.

Activating and deactivating

Applies to vehicles: with side assist



Fig. 112 Driver's door: Side assist button

- ▶ Press the button ⇒  in *General information on page 107* to switch the system on/off. The LED in the button turns on when side assist is switched on.

Adjusting the display brightness

Applies to vehicles: with side assist

The brightness setting can be adjusted via the MMI.

- ▶ Select: **CAR** function button > **Car systems control button** > **Driver assist** > **Audi side assist**.

The display brightness adjusts automatically to the brightness of the surroundings, both in the information and in the warning stage. In very dark or very bright surroundings, the display is already set to the minimum or maximum level by the automatic adjustment. In such cases, you may notice no change when adjusting the brightness, or the change may only be noticeable once the surroundings change.

Adjust the brightness to a level where the display in the information stage will not disrupt your view forward. If you change the brightness, the display in the exterior mirror will briefly show the brightness level in the information stage. The brightness of the warning stage is linked to the brightness in the information stage and is adjusted along with the information stage adjustment.

i Tips

- Side assist is not active while you are making the adjustment.
- Your settings are automatically stored and assigned to the remote control key being used.

Driver messages

Applies to vehicles: with side assist

If side assist switches off by itself, the LED in the button turns off and a message will appear in the instrument cluster display:

Audi side assist: Currently unavailable. No sensor vision

The radar sensors' vision is affected. Do not cover the area in front of the sensors with bike wheels, stickers, dirt or other objects. Clean the area in front of the sensors, if necessary
⇒ *page 107, fig. 111.*

Audi side assist: Currently unavailable

Side assist cannot be switched on temporarily because there is a malfunction (for example, the battery charge level may be too low).

Audi side assist: System fault!

The system cannot guarantee that it will detect vehicles correctly and it is switched off. The sensors have been displaced or are faulty. Have the system checked by an authorized Audi dealer or authorized Audi Service Facility soon.

Audi side assist: Unavailable when towing.

Side assist switches off automatically when a factory-installed trailer hitch is connected to the electrical connector on the trailer. There is no guarantee the system will switch off when using a retrofitted trailer hitch. Do not use side assist when towing a trailer.

Audi drive select

Driving settings

Introduction

Audi drive select makes it possible to experience different types of vehicle settings in one vehicle. The driver can select three **Comfort**, **Auto** and **Dynamic** modes in the MMI to switch between a sporty and a comfortable driving mode.

You can also adjust the setting according to your preferences in the **individual** mode. For example, you can combine settings such as a sporty engine tuning with comfortable steering.



WARNING

Improper use of the Audi drive select can cause collisions, other accidents and serious personal injury.

Description

The vehicle setup in each mode depends on the vehicle's features. The engine, transmission, steering, reversible safety belt tensioners and adaptive air suspension are always involved.

Engine and transmission

Depending on the mode, the engine and the transmission respond quicker or in a more balanced manner to accelerator pedal movements. In the sporty dynamic mode, the transmission shifts at higher RPMs.

Air suspension

The adaptive air suspension/adaptive air suspension sport* (**Air suspension** in the MMI) is an electronically controlled air suspension and damping system. They are adjusted depending on the selected driving mode, the driver's steering, braking and acceleration input and the road surface, vehicle speed and load. A sporty setting is generally used in vehicles with adaptive air suspension sport*.

The vehicle clearance varies depending on the selected mode and the speed.

The highway setting is activated automatically when you drive above 75 mph (120 km/h) for more than 30 seconds in the **auto** or **dynamic** mode. The ground clearance is increased automatically if the speed drops below 44 mph (70 km/h) for more than 120 seconds.

Steering

The steering adapts in terms of steering effort and steering ratios. Indirect steering that moves easily, like the steering in comfort mode, is best suited to long drives on a highway. In contrast, dynamic mode provides sporty, direct steering.

The following applies to vehicles with dynamic steering*: the steering ratio changes based on vehicle speed in order to maintain optimum steering effort for the driver at all times. This sets the steering to be less sensitive at higher speeds in order to provide improved vehicle control. At reduced speeds, however, steering is more direct in order to keep the steering effort as minimal as possible when the driver is maneuvering the vehicle. At low and average speeds, dynamic steering additionally provides more responsive steering performance.

Sport differential*

As a component of the all wheel drive system (quattro) ⇒ *page 204*, the Sport differential* distributes the driving power to the rear axle depending on the situation. The distribution of power varies depending on the selected mode, from balanced (comfort) to agile (dynamic). The goal is a high level of agility and ability to accelerate on curves. The vehicle is very responsive to steering.

Curve light*

The curve light adapts to driving on curves. The pivoting action and the lighting are also adapted to the mode.

Adaptive cruise control*

The behavior when accelerating can be adjusted from comfortable to sporty, depending on ►

the drive select mode. Adaptive cruise control also responds to the driving behavior of the vehicle ahead in a more conservative or sporty manner.

Engine sound*

The sound of the engine is adapted to the selected mode and ranges from subtle to sporty.

! Note

- Make sure there is enough clearance above and below the vehicle when parking. The height of the vehicle can change once it is parked due to temperature fluctuations, changes to the load conditions and changes to the driving modes, which can affect clearance.
- When transporting the vehicle on a car carrier, train, ship or by other means, only tie the vehicle down at the running surface of the tires, which is the outer circumference. Securing the vehicle at the axle components, suspension struts or towing eyes is not permitted because the pressure in the air suspension struts can change during transport. The vehicle may not be secured sufficiently if this happens.
- If you are going to tow a trailer, you must activate the trailer operation mode ⇒ *page 212*.

i Tips

- In some models, the maximum vehicle speed can only be reached in the **auto** and **dynamic** modes.
- Selecting the **dynamic** mode results in sporty shifting characteristics. The S gear position engages automatically.
- In vehicles that have dynamic steering*, operating noise is heard when starting or stopping the engine. This does not indicate a problem.

- In vehicles with sport differential*, the dynamic mode is deactivated when towing a trailer.

Selecting the driving mode

You can choose between *Comfort*, *Auto*, *Dynamic* and *Individual*.



Fig. 113 MMI: Drive select

- ▶ To select the mode, select the following in the MMI: **CAR** function button > **Comfort**, **Auto**, **Dynamic** or **Individual**.

You can change the driving mode when the vehicle is stationary or while driving. If traffic permits, after changing modes, briefly take your foot off the accelerator pedal so that the recently selected mode is also activated for the engine.

comfort - provides a comfort-oriented vehicle setup and is suited for long drives on highways.

auto - provides an overall comfortable yet dynamic driving feel and is suited for every day use.

dynamic - gives the driver a sporty driving feel and is suited to a sporty driving style.

individual - ⇒ *page 112*.

! WARNING

Pay attention to traffic when operating Audi drive select to prevent potential risk of an accident.

Adjusting the Individual mode

You can adjust the vehicle settings to your personal preferences.

- ▶ Select: **CAR** function button > **Set individual** control button. You can now adjust the individual systems.

The **individual** driving mode will automatically be activated when you have finished configuring the settings.

The equipment in your vehicle will determine which settings you can adjust. The following table provides an overview of the characteristics of each driving mode.

Systems	Comfort	Auto	Dynamic
Engine and Transmission	balanced	balanced	sporty
Air suspension	comfortable	balanced	sporty
Steering	comfortable	balanced	sporty
Dynamic steering*	comfortable/indirect	balanced/direct	sporty/direct
Sport differential*	balanced	agile	sporty
Curve light*	comfortable	balanced	sporty
Belt tensioner	Standard	Standard	Deployment time adapted
Adaptive cruise control*	comfortable	balanced	sporty
Engine sound*	subtle	subtle/sporty ^{a)}	sporty

^{a)} Subtle in the driving position D and sporty in the driving position S

Tips

Your **individual** mode settings are automatically stored and assigned to the remote control key being used.

Raising/lowering the vehicle

Raising the vehicle

You can raise your vehicle temporarily, for example to drive over a tall curb.

- ▶ Select the following in the MMI: **CAR** function button > **Raise** control button.
- ▶ Wait for the arrows in the display to stop blinking and the vehicle to reach its final position.

Lowering the vehicle

- ▶ To lower the vehicle, select the following in the MMI: **CAR** function button > **Lower** control button.

- ▶ Wait for the arrows in the display to stop blinking and the vehicle to lower completely.

Note

- Remember that your vehicle is not suitable for driving offroad even when it is raised. There is not enough ground clearance.
- If the vehicle is raised, it will lower automatically when driving 62 mph (100 km/h) or faster.

Driver messages

Air suspension: vehicle currently too low. Level control running

Air suspension: vehicle currently too high. Level control running

The driver message switches off when the level control process is complete.

Night vision assistant

Description

Applies to vehicles: with night vision assistant



Fig. 114 Display: night vision assistant

“Night vision assistant with pedestrian detection” uses an infrared camera to monitor the area in front of your vehicle at night. Within the limits of the system, it can display objects up to about 1000 feet (300 meters) away. The heat image of a pedestrian detected by the camera is shown in the instrument cluster display ⇒ *fig. 114*. Warm areas appear lighter and cold areas appear darker.

Pedestrian detection

Applies to vehicles: with night vision assistant



Fig. 115 Display: yellow pedestrian marking

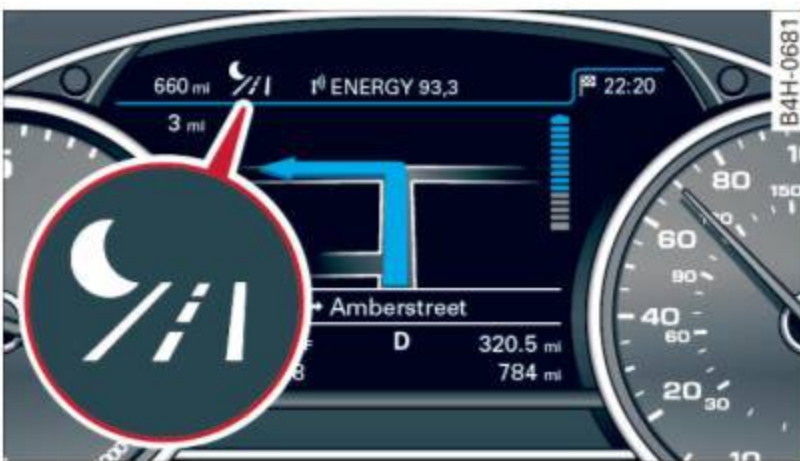



Fig. 116 Display: symbol when infrared image is not visible

Night vision assistant can detect pedestrians that are between about 50 and 300 feet (15 and 90 meters) in front of the vehicle, under ideal conditions. If a pedestrian is detected when it is dark outside and the vehicle headlights are switched on, the pedestrian is highlighted in yellow ⇒ *fig. 115*, ⇒ *page 114*, *General information*. If another display such as navigation replaces the image from the night vision assistant, the symbol  appears in a tab ⇒ *fig. 116*.

Tips

If the night vision assistant image does not appear when the system is switched on, you can access it with the buttons on the multifunction steering wheel ⇒ *page 25*.

Pedestrian warning

Applies to vehicles: with night vision assistant



Fig. 117 Display: pedestrian warning



Fig. 118 Display: pedestrian warning with another display

If a pedestrian is detected in an area in front of the vehicle that the system considers critical, the pedestrian is highlighted in red ⇒ *fig. 117* and a warning tone sounds. This area is based on the vehicle speed and

steering angle. The pedestrian warning prompts you to pay even closer attention to the area in front of the vehicle and to watch out for pedestrians.

If another display such as the trip computer replaces the image from the night vision assistant, the indicator light turns red when there is a pedestrian warning  ⇒ *fig. 118*.

Tips

The pedestrian marking and warning tone can be adjusted in the MMI ⇒ *page 115*.

General information

Applies to vehicles: with night vision assistant



Fig. 119 Front of the vehicle: night vision assistant camera

The following situations may affect the function of the night vision assistant system:

- poor visibility such as snow, rain, fog or heavy road spray
- dirty lens on the night vision assistant camera

Make sure the night vision assistant camera ⇒ *fig. 119* is not covered by stickers, deposits or any other obstructions because that can prevent the camera from working properly. For information on cleaning the lens, refer to ⇒ *page 216*.

Pedestrian detection depends on the difference in temperature between the person and the background. Pedestrians may not be detected if the temperature difference is too small. The pedestrian highlighting feature is deactivated at temperatures above 77 °F (25 °C) and when it is light outside.

WARNING

Night vision assistant has limits and cannot always detect pedestrians. Always pay close attention to traffic and the area around your vehicle even when night vision assistant is switched on.

- Night vision assistant can only warn about people located within the visual range of the infrared camera. The visual range corresponds to the image in the instrument cluster display.
- Night vision assistant may not detect people and highlight them if
 - they are not in an upright position, for example if they are sitting, crouching or lying down and/or
 - if the outline in the display is incomplete or interrupted, for example because the person is partially hidden by a parked vehicle.

Tips



- Pedestrian detection and the pedestrian warning are limited to objects that are detected as pedestrians. The system does not detect animals. Even though the shape and warmth radiated by each object detected is evaluated, the system does have limitations and it can give incorrect warnings.
- For technical reasons, the image pauses in split second intervals.

Switching on and off

Applies to vehicles: with night vision assistant



Fig. 120 Area around the light switch: night vision assistant button

- ▶ Switch the ignition on and turn the light switch to the **AUTO** position or .
- ▶ To switch night vision assistant on, press the  button ⇒ *fig. 120*. The image from the night vision camera appears in the instrument cluster display.
- ▶ Press the button  again to switch night vision assistant off.

Settings in the MMI

Applies to vehicles: with night vision assistant



Fig. 121 Display: example of pedestrian detection and warning tone switched off

- ▶ Select: **CAR** function button > **Car systems** control button > **Driver assist** > **Night vision assist**.

Highlight pedestrians - You can switch pedestrian detection **on** and **off**. If you switch pedestrian detection off, the pedestrian warning tone also switches off. The symbols  and  appear in the upper right area of the instrument cluster display ⇒ *fig. 121*.

Warning tone - You can switch the tone for the pedestrian warning **on** and **off**. When the warning tone is switched off, a yellow symbol for the deactivated warning tone with a line through it appears in the upper right of the instrument cluster display ⇒ *fig. 121*.

Contrast - When the night vision assistant is switched on and the image is visible in the instrument cluster display, you can adjust the contrast in the image from **Min** to **Max**.

Driver messages

Applies to vehicles: with night vision assistant

Night vision assistant: system malfunction!

The system cannot work properly and is switched off. See your authorized Audi dealer for assistance.

Night vision assistant: not available

The system cannot detect properly under current conditions and is switched off temporarily.

Night vision assistant: only available in darkness and with lights switched on

Night vision assistant only works when it is dark outside and the headlights are on.

Night vision assistant: pedestrian detection not available

The system has deactivated the pedestrian detection function.

Automatic Transmission

tiptronic (8-speed transmission)

Introduction

Your vehicle is equipped with an electronically controlled 8-speed automatic transmission.

Upshifting and downshifting occurs automatically and is controlled electronically. The driving style continuously influences the selection of the driving program.

When a **moderate driving style** is used, the transmission selects the most economical driving mode. It will then change up early and delay the downshifts to give better fuel economy.

The transmission switches to a sporty mode after a kick-down or when the driver uses a **sporty driving style** characterized by quick accelerator pedal movements, heavy acceleration, frequent changes in speed and traveling at the maximum speed.

If desired, the driver can also select the gears manually (**tiptronic mode**) ⇒ page 119.

Indicator in the display



Fig. 122 Display: selector lever position

(A) - The current selector lever position is displayed continuously. The gear is also displayed in manual mode M.

(B) - This indicator appears temporarily if you change the selector lever position or if you press the button on the selector lever

⇒ page 116, fig. 123. The current selector lever position is shown with a white background.

Selecting a selector lever position



Fig. 123 Selector lever

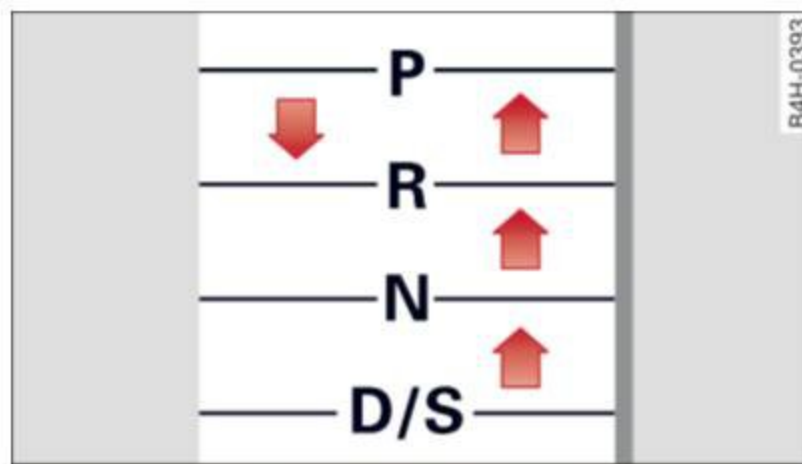

Fig. 124 Pressing the button on the selector lever

The current selector lever position is displayed on the selector lever ⇒ fig. 123.

- ▶ You may need to release the selector lever lock depending on which selector lever position is selected and which one you would like to select ⇒ page 117, *Selector lever lock*.
- ▶ To engage the nearest selector lever position, move the selector lever forward/back until you feel the first pressure point. The selector lever will return to its original position.
- ▶ To skip over one (or two) selector lever positions, move the selector lever past the first (and second) pressure point into the desired position. The selector lever will return to its original position.

For example, to move directly from the D selector lever position to P when stopping the vehicle, you can shift past the N and R selector lever positions. ▶

Selector lever lock

The selector lever lock prevents you from selecting a position unintentionally, causing the vehicle to roll. When engaging some selector lever positions, you must press the button on the selector lever ⇒ *fig. 123* and/or press the brake pedal.

You must press the brake pedal to engage a selector lever position when the engine is running while the vehicle is stationary. The arrows ⇒ *fig. 124* indicate when you need to press the button on the selector lever.

The selector lever does not lock if you shift from D to R within one second. This allows you to “rock” the vehicle to free it when it is stuck.

P - Park

The wheels are locked in this position. Only shift into park when the vehicle is stationary ⇒ . To engage the P selector lever position, press the button on the selector lever and shift into the P position.

You can only shift out of park when the engine is running and you are pressing the brake pedal. Press the button on the selector lever to release the parking lock and select the desired selector lever position.

P engages automatically when you switch the engine off while D, S or R is engaged or in manual mode.

If you switch the engine off when N is engaged, the transmission remains in N for approximately 30 minutes and then P is engaged.

You must use the emergency release procedure to release the parking lock before towing the vehicle ⇒ *page 121*.

R – Reverse

The reverse gear is engaged in this position. Only select reverse when the vehicle is stationary and the engine is running at idle speed ⇒ . To engage the R selector lever position, press the button on the selector lever, press

the brake pedal and move the selector lever into the R position.

The back-up lights turn on when you select the R selector lever position while the engine is running.

N - Neutral



The transmission is in idle in this position. To engage the N selector lever position, press the button on the selector lever and shift into the N position.

If you switch the engine off when N is engaged, the transmission remains in N for approximately 30 minutes and then P is engaged.

You cannot select the N position when the ignition is switched off. When driving through an automatic car wash, first select the N position and then switch the engine off ⇒ *table on page 218*.

The vehicle cannot be locked when the selector lever is in the N position.

D/S - Position for driving forward

In the D/S position, the transmission can be operated either in the normal mode D or in the sport mode S. You can only select the S selector lever position when D is engaged. Move the selector lever back to engage the S selector lever position. To select the D selector lever position again when S is engaged, move the selector lever back ⇒ . To shift from N to D when traveling at speeds below 1 mph (2km/h), press the brake pedal and select the D selector lever position ⇒ .

In the **normal mode** D, the transmission automatically selects the suitable gear ratio. It depends on engine load, vehicle speed and driving style.

Select the **sport mode** S for sporty driving. The vehicle makes full use of the engine's power. Shifting may become noticeable when accelerating.

The S selector lever position engages automatically when you select the dynamic mode in Audi drive select. ▶

! WARNING

- Never engage R or P while driving. It could cause a crash.
- Power is still transmitted to the wheels when the engine is running at idle. To prevent the vehicle from “creeping”, you must keep your foot on the brake in all selector lever positions except P and N when the engine is running. Do not inadvertently press the accelerator pedal when the vehicle is stationary. Otherwise the vehicle will start to move immediately. This could happen even if the parking brake is activated.
- Before opening the hood, select the P selector lever position and set the parking brake. This reduces the risk of a crash. Always read and follow the applicable warnings ⇒ *page 231*.
- Never get out of the driver’s seat when the engine is running.
- If you must get out of the vehicle, move the selector lever securely into the P position and apply the parking brake.

i Tips

- If you unintentionally shift into the N selector lever position while driving, take your foot off the accelerator pedal and wait for the engine to slow down until it is idling before you shift into D or S.

Driving tips

The gears shift automatically.

Starting from a stop

- ▶ Press and hold the brake pedal.
- ▶ Start the engine ⇒ *page 84*.
- ▶ Press the button on the selector lever and select the D, S or R selector lever position ⇒ *page 116*.
- ▶ Wait a moment until the transmission shifts. You will notice a slight movement when the gear engages.
- ▶ Release the brake pedal and press the accelerator pedal ⇒ .

Stopping temporarily

- ▶ Press the brake pedal to stop the vehicle, for example at a traffic light. Do not press the accelerator pedal when doing this.
- ▶ To prevent the vehicle from rolling when you start driving, set the parking brake when stopping on large inclines ⇒ .
- ▶ The parking brake will release automatically and the vehicle will start moving once you press the accelerator pedal.

Parking

If the selector lever is not in the P position when you open the driver’s door, the vehicle could roll. The message **Transmission: Car may roll! Shift to park!** appears.

- ▶ Press and hold the brake pedal ⇒ .
- ▶ Set the parking brake.
- ▶ To engage the P selector lever position, press the button on the selector lever and shift into the P position ⇒ *page 116*.

Under certain conditions such as driving in the mountains or when towing a trailer, it may be helpful to switch to manual mode temporarily to shift *manually* to adapt to the driving conditions ⇒ *page 119*.

On slopes, activate the parking brake first and then move the selector lever to the P position. This prevents too much stress from being placed on the locking mechanism.

! WARNING

Read and follow all WARNINGS ⇒  in *Selecting a selector lever position on page 118*.

- The vehicle can also roll when the engine is stopped.
- Do not press the accelerator pedal when changing the selector lever position while the vehicle is stationary and the engine is running. This could result in a crash.
- Never engage R or P while driving. It could cause a crash.
- Power is still transmitted to the wheels when the engine is running at idle. To

prevent the vehicle from “creeping”, you must keep your foot on the brake in all selector lever positions except P and N when the engine is running. Do not inadvertently press the accelerator pedal when the vehicle is stationary. Otherwise the vehicle will start to move immediately, even if the parking brake is set. This could result in a crash.

- Do not ride the brakes or press the brake pedal too often or too long when driving down a hill. Constant braking causes the brakes to overheat and substantially reduces braking performance, increases braking distance or causes complete failure of the brake system.

Hill descent control

The hill descent control system assists the driver when driving down declines.

Hill descent control is activated when the selector lever is in D/S and you press the brake pedal. The transmission automatically selects a gear that is suitable for the incline. Hill descent control tries to maintain the speed achieved at the time of braking, within physical and technical limitations. It may still be necessary to adjust the speed with the brakes.

Hill descent control switches off once the decline levels out or you press the accelerator pedal.

Hill descent control is also activated when the speed is set by starting the cruise control system ⇒ *page 91*.

WARNING







Hill descent control cannot overcome physical limitations, so it may not be able to maintain a constant speed under all conditions. Always be ready to apply the brakes.

Shifting manually

The shift paddles allow the driver to shift the gears manually.



Fig. 125 Steering wheel: shifting manually

- ▶ To shift to a higher or lower gear temporarily, tap the  or  shift paddle ⇒ *fig. 125*.
- ▶ To switch manual mode on, press the  button. An M and the gear that is currently engaged appear in the instrument cluster display  ⇒ *page 116, fig. 122*.
- ▶ To shift up one gear, tap the right shift paddle .
- ▶ To shift down one gear, tap the left shift paddle .
- ▶ To switch manual mode off, press the  button again, or
- ▶ Move the selector lever back and release it.

The transmission automatically shifts up or down before critical engine speed is reached.

The transmission only allows manual shifting when the engine speed is within the permitted range.

The engine braking effect increases when you downshift when going downhill.

Kick-down

Kick-down enables maximum acceleration.

When you press the accelerator pedal down beyond the resistance point, the automatic transmission downshifts into a lower gear, depending on vehicle speed and engine RPM. It shifts up into the next higher gear once the maximum specified engine RPM is reached. ▶

! WARNING

Please note that the wheels could spin on slick or slippery roads when kick-down is active.

Transmission malfunction**! Transmission: please press the brake pedal and select the position again**

Press the brake pedal and select the desired selector lever position again. You can then continue driving.

! Transmission hot: please modify driving style

The transmission temperature has increased significantly due to the sporty driving manner. Drive in a less sporty manner until the temperature returns to the normal range and the indicator light switches of.

! Gearbox malfunction: you can continue driving

There is a system malfunction in the transmission. You may continue driving. Drive to your authorized Audi dealer or qualified repair facility soon to have the malfunction corrected.

! / R Gearbox malfunction: you can continue driving in D only until engine is off

There is a system malfunction in the transmission. The transmission is switching to emergency mode. If you turn the engine off, you will not be able to select any other selector lever positions after starting the engine again. Drive to your authorized Audi dealer or qualified repair facility immediately to have the malfunction corrected.

! Gearbox malfunction: you can continue driving (limited functionality)

There is a system malfunction in the transmission. The transmission is switching to emergency mode. This mode only shifts into certain gears or will not longer shift at all. The engine may stall. Drive to your authorized Audi dealer or qualified repair facility immediately to have the malfunction corrected.

! / R Gearbox malfunction: no reverse gear (you can continue driving)

There is a system malfunction in the transmission. The transmission is switching to emergency mode. This mode only shifts into certain gears or will not longer shift at all. You cannot engage the reverse gear. Drive to your authorized Audi dealer immediately to have the malfunction corrected.

! Vehicle may roll! Cannot shift to P. Please apply parking brake

- The parking lock was released using the emergency release ⇒ *page 121*. Or
- The parking brake cannot engage automatically. Drive to your authorized Audi dealer or qualified repair facility immediately to have the malfunction corrected.

! Gearbox malfunction: Stop and shift to P

Do not continue driving. Select the P selector lever position and see your authorized Audi dealer or qualified repair facility for assistance.

Parking lock emergency release

The parking lock must be released using the emergency release before towing the vehicle.



Fig. 126 Driver's side footwell: releasing the parking lock using the emergency release



Fig. 127 Driver's side footwell: resetting the parking lock

The emergency release is located under the floor mat on the driver's side. You operate the emergency release from the driver's seat.

Releasing the parking lock using the emergency release

- ▶ To prevent the vehicle from rolling unintentionally, set the parking brake (P) ⇒ page 86 or press the brake pedal.
- ▶ There are two slits on the cover. Position the screwdriver from the vehicle tool kit in one of the slits on the cover and pry the cover off.
- ▶ Pull the band (A) in the direction of the arrow until the release lever locks in place ⇒ fig. 126.
- ▶ Fold the upper section of the release lever down into the recess.

Resetting the parking lock

- ▶ Press the button (B) and the release lever at the same time. You can now push the lever

back into its original position. Make sure the lever locks in place ⇒ fig. 127.

- ▶ Install the cover.

The indicator light  and the N position indicator in the instrument cluster turn on when the parking lock is released using the emergency release. The message **Risk of rolling! P not possible. Please set the parking brake** also appears.

WARNING

If you release the parking lock using the emergency release, secure your vehicle with the parking brake or the brake pedal if the parking brake is not working. The vehicle can roll away if it is not secured and cause a crash.

Parking systems

General information

Applies to vehicles: with parking system plus/rear view camera/peripheral cameras

Depending on your vehicle's equipment, various parking aids will help you when parking and maneuvering.

The **advanced parking system with rear view camera** assists you when parking by audibly and visually indicating objects detected *in front of* and *behind* the vehicle. The rear view camera shows the area behind the vehicle in the Infotainment display. This display assists you when you are cross or parallel parking ⇒ *page 123*.

The **peripheral cameras** assist you with parking and maneuvering. You are aided by various cameras depending on the vehicle equipment level ⇒ *page 127*. In addition, you are assisted by the functions from the sensors ⇒ *page 123, Sensors*, ⇒ *page 125, Visual display*.

WARNING

- Always look for traffic and check the area around your vehicle by looking at it directly as well. The parking system cannot replace the driver's attention. The driver is always responsible for safety during parking and for all other maneuvers.
- Please note that some surfaces, such as clothing, are not detected by the system.
- Sensors and cameras have blind spots in which people and objects cannot be detected. Be especially cautious of children and animals.
- The sensors can be displaced by impacts or damage to the radiator grille, bumper, wheel housing and the underbody. The parking systems may become impaired as a result. Have your authorized Audi dealer or qualified workshop check their function.
- Make sure the sensors are not covered by stickers, deposits or any other obstructions as it may impair the sensor func-

tion. For information on cleaning, refer to ⇒ *page 216*.

Note

- Some objects are not detected by the system under certain circumstances:
 - Objects such as barrier chains, trailer draw bars, vertical poles or fences
 - Objects above the sensors such as wall extensions
 - Objects with specific surfaces or structures such as chain link fences or powder snow.
- If you continue driving closer to a low-lying object, it may disappear from the sensor range. Note that you will no longer be warned about this obstacle.

Tips

- The system may provide a warning even though there are no obstacles in the coverage area in some situations, such as:
 - certain road surfaces or for long grass.
 - external ultrasonic sources e.g. from cleaning vehicles.
 - heavy rain, snow or thick vehicle exhaust.
- We recommend that you practice parking in a traffic-free location or parking lot to become familiar with the system. When doing this, there should be good light and weather conditions.
- You can change the volume and pitch of the signals as well as the display ⇒ *page 132*.
- Please refer to the instructions for towing a trailer ⇒ *page 132*.
- What appears in the infotainment display is somewhat time-delayed.

Advanced parking system with rear view camera

Introduction

Applies to vehicles: with advanced parking system with rear view camera

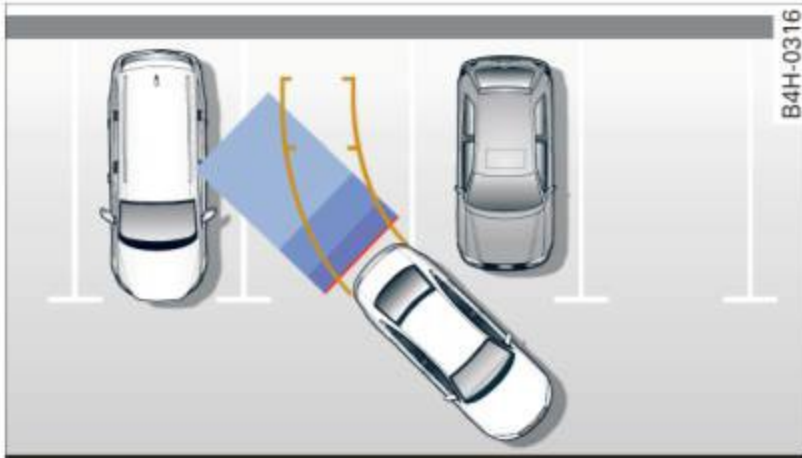

Fig. 128 Illustration: Cross parking

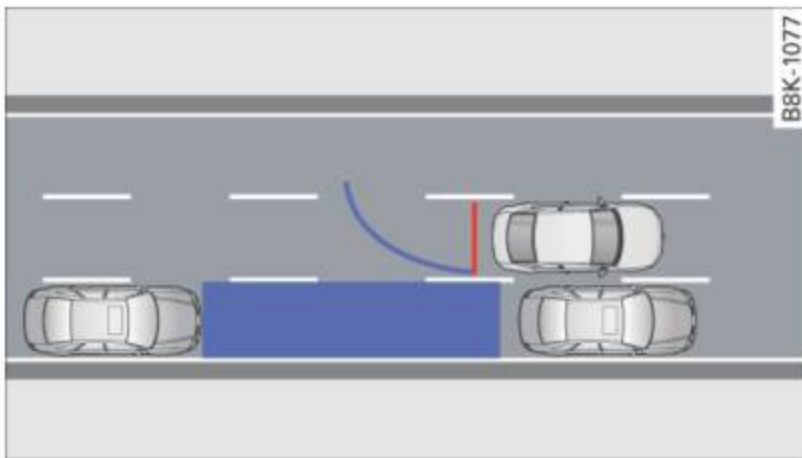

Fig. 129 Illustration: parallel parking

Vehicles with the parking system advanced are equipped with a rear view camera in addition to the acoustic and visual parking system.

You can use *cross parking* for example, to park in a parking space or in a garage ⇒ *fig. 128*. You can use *parallel parking* if you would like to park on the side of the road ⇒ *fig. 129*.

General information

Applies to vehicles: with advanced parking system with rear view camera

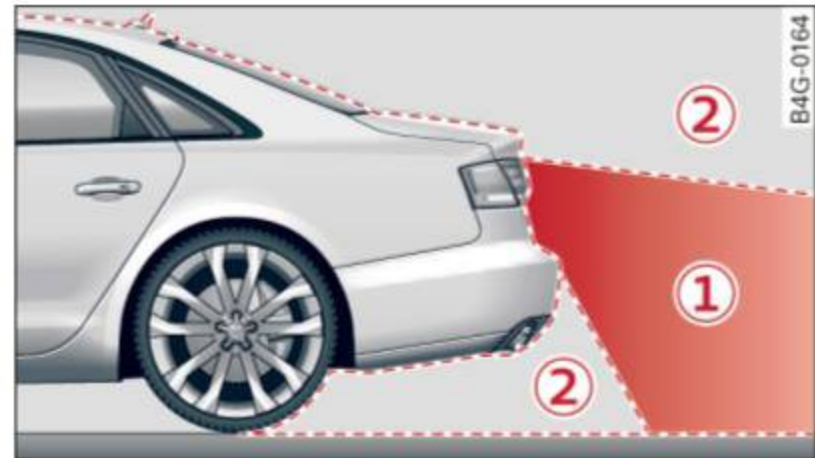

Fig. 130 Area covered (1) and area not covered (2) by the rear view camera



Fig. 131 Rear lid: Location of the rear view camera

Sensors

Sensors are located in the front and rear bumpers. If these detect an obstacle, visual and in some situations audible signals warn you.

Make sure the sensors are not covered by stickers, deposits or any other obstructions as it may impair the sensor function. For information on cleaning, refer to ⇒ *page 216*.

The display field begins approximately at:

front	side	3 ft (0.90 m)
	center	4 ft (1.20 m)
rear	side	2 ft (0.60 m)
	center	5.2 ft (1.60 m)

The closer you get to the obstacle, the shorter the interval between the audible signals. A continuous tone sounds when the obstacle is less than approximately 1 ft (0.30 m) away. Do not continue driving farther ⇒ ⚠ in *General information on page 122*, ⇒ ⚠ in *General information on page 122!*

If the distance to an obstacle remains constant, the volume of the distance warning gradually drops after about four seconds (this does not apply in the continuous tone range).

Rear view camera

The rear view camera is located above the rear license plate bracket. Make sure that the lens for the parking system ⇒ *fig. 131* is not covered by deposits or any other obstructions because this can affect the function of the parking system. For information on cleaning, refer to ⇒ *page 216*.

The rear view camera coverage area includes ① ⇒ *fig. 130*. Only this area is shown in the Infotainment display. Objects that are outside of this area ② are not displayed.

The accuracy of the orientation lines and the blue surfaces is reduced if the adaptive air suspension* is faulty, if the vehicle is lifted or if the **dynamic** mode is activated ⇒ *page 110*.

WARNING

- Always read and follow the applicable warnings ⇒  in *General information on page 122*.
- If the position and the installation angle of the rear view camera was changed, for example, after a collision, do not continue to use the system for safety reasons. Have it checked by your authorized Audi dealership or authorized repair facility.
- Only use the rear view camera to assist you if it shows a good, clear picture. For example, the image may be affected by the sun shining into the lens, dirt on the lens or if there is a system fault.
- Use the rear view camera only if the luggage compartment lid is completely closed. Make sure any objects you may have mounted on the luggage compartment lid do not block the rear view camera.
- The camera lens enlarges and distorts the field of vision. The object appears both altered and inaccurate on the screen.

- In certain situations, people or objects in the display appear closer or further away:
 - objects that do not touch the ground, such as the bumper of a parked vehicle, a trailer hitch or the rear of a truck. Do not use the help lines in this case.
 - If driven from a level surface onto an incline, or a downward slope.
 - If driven toward protruding objects.
 - If the vehicle is carrying too much load in the rear.

Note

- Always read and follow the applicable warnings ⇒  in *General information on page 122*.
- The orange colored orientation lines in the Infotainment display show the vehicle path depending on the steering wheel angle. The front of the vehicle front swings out more than the rear of the vehicle. Maintain plenty of distance so that your outside mirror or a corner of your vehicle does not collide with any obstacles.

Switching on/off

Applies to vehicles: with advanced parking system with rear view camera



Fig. 132 Center console: Parking system switch



Fig. 133 Infotainment: visual distance display

Switching on

- ▶ Shift into reverse or
- ▶ press the **P** button in the center console ⇒ *fig. 132*. A short confirmation tone sounds and the LED in the button turns on.

Switching between the rear view camera and optical display

- ▶ Press the **Graphic** control button (5) ⇒ *page 125, fig. 134* to see the optical display.
- ▶ Press the **Rearview** control button to see the rear view camera image.

Switching off

- ▶ Drive forward faster than 6 mph (10 km/h), or
- ▶ Press the **P** button, or
- ▶ Switch the ignition off.

Visual display

Using the segments, you can estimate the distance to an object in front of or behind the vehicle ⇒ *fig. 133*. The red lines mark the ex-

pected direction of travel according to the steering angle. A white segment indicates an identified obstacle that is outside of the vehicle's path. Red segments show identified obstacles that are in your vehicle's path. As your vehicle comes closer to the obstacle, the segments move closer to the vehicle. At the latest the collision area has been reached when the next to last segment is displayed. Obstacles in the collision area, including those outside of the vehicle's path, are shown in red. Do not continue driving farther forward or in reverse ⇒ ⚠ in *General information on page 122*, ⇒ ⚠ in *General information on page 122*.

i Tips

The visual display in the left part of the display should help you detect the critical vehicle areas.

Cross parking

Applies to vehicles: with advanced parking system with rear view camera

This view may be used when parking in a garage or in a parking space.

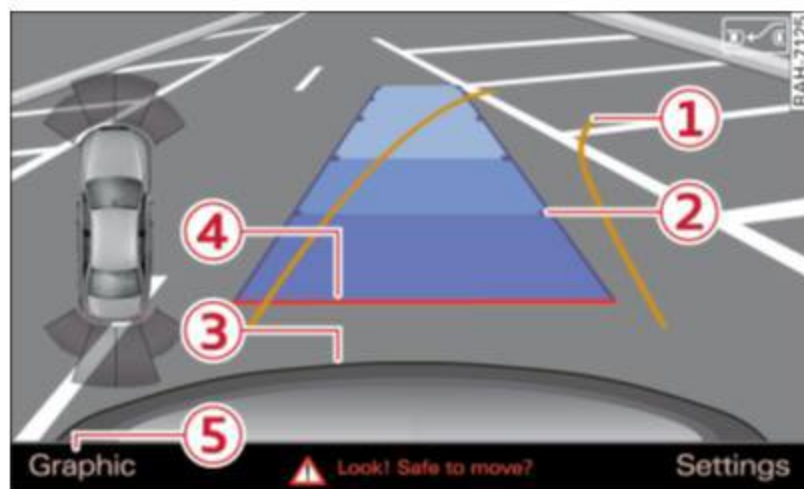

Fig. 134 Infotainment: aiming at a parking space

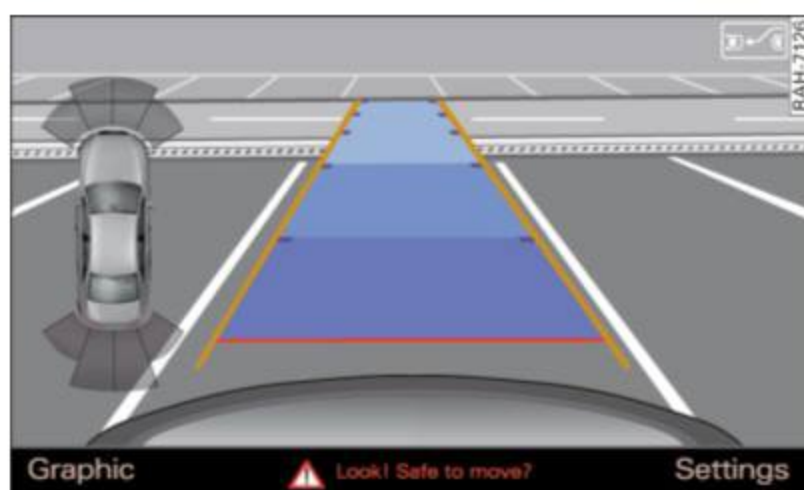

Fig. 135 Infotainment: aligning the vehicle

- ▶ Turn the Infotainment on and shift into reverse gear.
- ▶ The orange colored orientation lines ① show the direction of travel of the vehicle. Turn the steering wheel until the orange orientation lines appear in the parking space ⇒ *fig. 134*. Use the markings ② to help you estimate the distance from an obstacle. Each marking represents about 3 ft (1 m). The blue area represents an extension of the vehicle's outline by approximately 16 ft (5 m) to the rear.
- ▶ While driving in reverse gear, adjust the steering wheel angle to fit the parking space with the aid of the orange orientation lines ⇒ ⚠ in *General information on page 124*, ⇒ ! in *General information on page 124*. ③ marks the rear bumper. Stop the vehicle when the red orientation line ④ borders an object.

Parallel parking

Applies to vehicles: with advanced parking system with rear view camera

This view may be used when parallel parking along the side of a street.

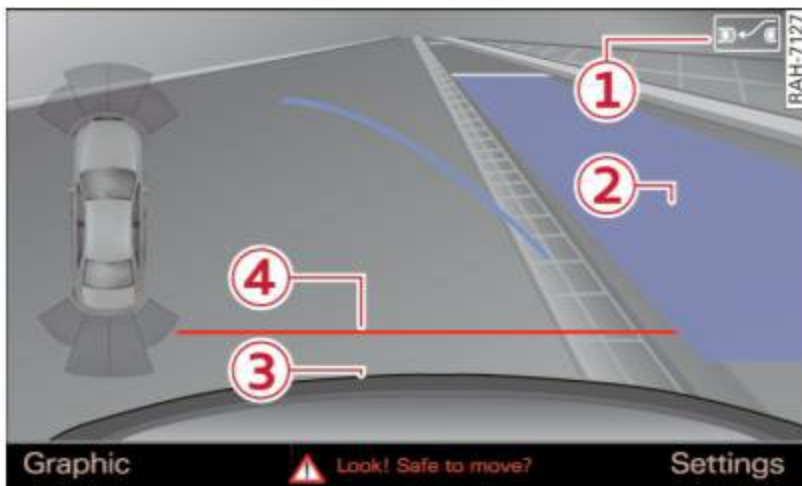

Fig. 136 Infotainment: blue surface aligned in the parking space

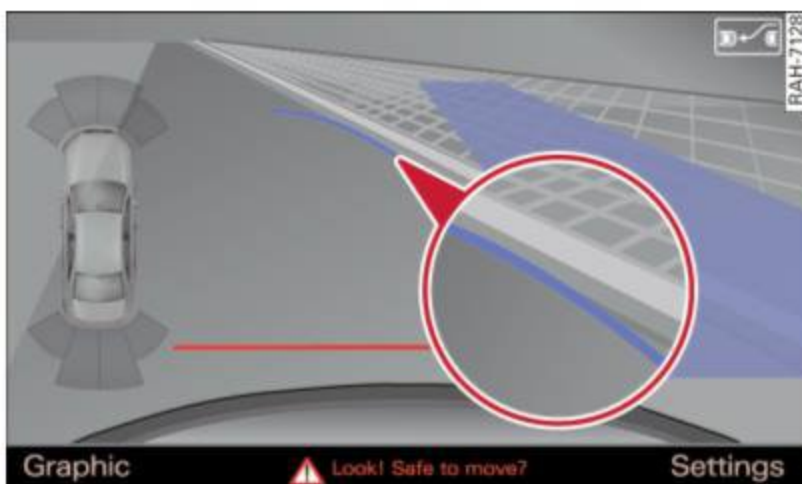

Fig. 137 Infotainment: contact of the blue curved line with the curb

Parking on the right is described here. It is identical when parking on the left.

If there is an obstacle next to the parking space (such as a wall), refer to information for "Parking next to obstacles" ⇒ *page 126*.

- ▶ Activate the turn signal.
- ▶ Position your vehicle next to a parked vehicle in front of the desired parking space. The distance to this vehicle should be approximately 3 ft (1 m).
- ▶ Turn the Infotainment on and shift into reverse gear. The parking system is turned on and the *cross parking* indicator is displayed.
- ▶ Press the control button on the Infotainment unit ① ⇒ *fig. 136*. The *parallel parking* indicator is displayed.
- ▶ Back up and align your vehicle so the blue area ② borders on the rear end of the vehicle behind you or on the parking space line ⇒ ⚠ in *General information on page 124*, ⇒ ! in *General information on page 124*. The blue area represents an extension of the vehicle's outline by approximately 16 ft (5 m) to the rear. The long side of the blue area should be on the curb. The entire blue area must fit into the parking space.
- ▶ With the vehicle stopped, turn the steering wheel to the right as far as it will go.
- ▶ Back into the parking space until the blue curve ⇒ *fig. 137* touches the curb ⇒ ⚠ in *General information on page 124*, ⇒ ! in *General information on page 124*. Stop the vehicle.
- ▶ With the vehicle stopped, turn the steering wheel to the left as far as it will go.
- ▶ Continue to back into the parking space until the vehicle is parked parallel to the curb ⇒ ⚠ in *General information on page 124*, ⇒ ! in *General information on page 124*. ③ marks the rear bumper. Stop the vehicle, at the latest, when the red orientation line ④ borders an object. Keep an eye on the front of your vehicle while doing this.

Parking next to obstacles

If there is an obstacle (such as a wall) next to the parking space, position the vehicle so there is more space on that side. Position the

long side of the blue surface so that there is sufficient space from the obstacle. The surface must not be touching. You will also need to start turning the steering wheel much earlier. The blue curve ⇒ *fig. 137* must **not** touch the obstacle and should have sufficient room.

i Tips

The left or right orientation lines and surfaces will be displayed, depending on the turn signal being used.

Peripheral cameras

Introduction

Applies to vehicles: with top view camera system

In addition to the functions from the sensors ⇒ *page 123, Sensors*, ⇒ *page 125, Visual display*, this parking system contains peripheral cameras. Depending on the vehicle equipment, you are assisted by various views such as peripheral view, corner views at the front and rear of the vehicle, and views directly in front of or behind the vehicle.

General information

Applies to vehicles: with top view camera system

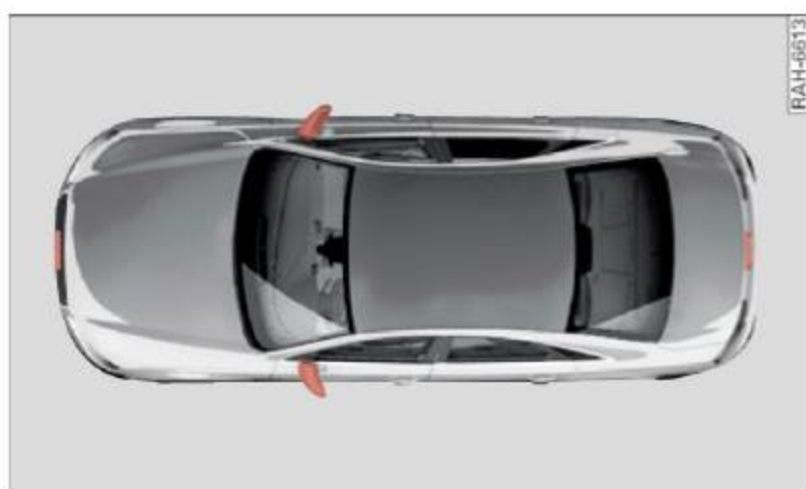

Fig. 138 Location of peripheral cameras

Depending on the vehicle equipment, the peripheral cameras are found in the radiator grille, in the luggage compartment lid and on both exterior mirrors ⇒ *fig. 138*. Make sure that the lenses are not covered by deposits or any other obstructions as it may impair the system. For information on cleaning, refer to ⇒ *page 216*.

In the **top view** mode, black corners are shown in the vehicle silhouette. Objects in these areas are outside of the camera's field of view and are not detected.

The accuracy of the orientation lines and the blue surfaces is reduced if the adaptive air suspension* is faulty, if the vehicle is lifted or if the **dynamic** mode is activated ⇒ *page 110*.

! WARNING



- Always read and follow the applicable warnings ⇒ **!** in *General information on page 122*.
- If the position or the installation angle of a camera was changed, after a collision for example, do not continue to use the system for safety reasons. Have it checked by your authorized Audi dealership.
- Keep in mind that the image in the display is distorted if the exterior mirror housing has been manually adjusted.
- Use the **rear** mode and the **corner view (rear)** mode only when the luggage compartment lid is fully closed. Otherwise the image in the display will be distorted.
- The vehicle surroundings are shown using the camera images. The vehicle image is shown by the system. Objects and obstacles above the camera are not displayed.
- Camera lenses enlarge and distort the field of vision. The objects appear both altered and inaccurate on the screen.

! Note

- Always read and follow the applicable warnings ⇒ **!** in *General information on page 122*.
- The Infotainment display shows the direction in which the rear of the vehicle is traveling based on the steering wheel angle. The front of the vehicle front swings out more than the rear of the vehicle. Maintain plenty of distance so that

your outside mirror or a corner of your vehicle does not collide with any obstacles.

i Tips

If the / /  symbol appears in the display and the respective display area is grayed out, then the power exterior mirrors were folded in or the driver's door/ front passenger's door/luggage compartment lid was opened.

Switching on or off

Applies to vehicles: with top view camera system



Fig. 139 Center console: P button

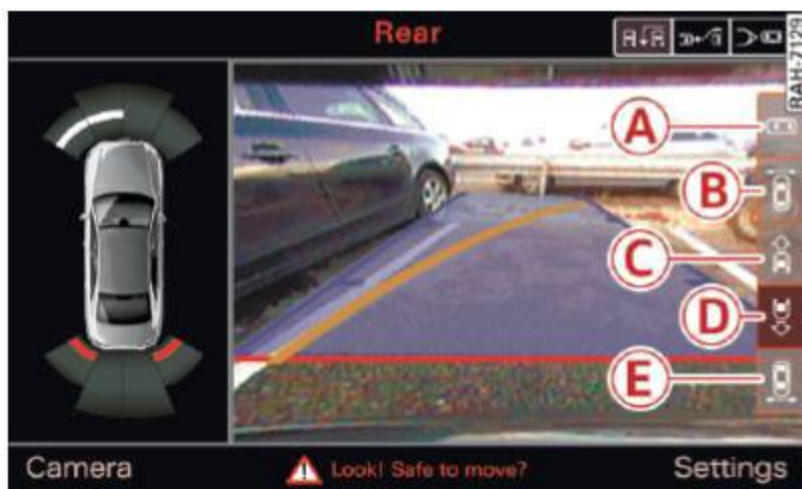

Fig. 140 Infotainment: selecting the mode

Switching on

- ▶ Shift into reverse, or
- ▶ Press the P button in the center console ⇒ *fig. 139*. A short confirmation tone sounds and the LED in the button turns on.

Selecting the mode

- ▶ Turn the control knob to the symbol for the desired mode (A) through (E) ⇒ *fig. 140*.

Switching off

- ▶ Drive forward faster than 6 mph (10 km/h), or
- ▶ Press the P button, or
- ▶ Switch the ignition off.

You may select from the following modes:

- (A) - Top view* ⇒ *page 128*
- (B) - Corner view (front)* ⇒ *page 129*
- (C) - Front* ⇒ *page 129*
- (D) - Rear* ⇒ *page 129*
- (E) - Corner view (rear)* ⇒ *page 129*

Top view

Applies to vehicles: with top view camera system and top view mode



Fig. 141 Infotainment: top view mode

This view is ideal for maneuvering. The vehicle surroundings are shown using the camera images. The vehicle image is shown by the system.

Selecting top view

- ▶ Select the (A) symbol with the control knob.

Switching between optical view and camera image¹⁾

- ▶ To display the camera image, press the **camera** control button (G).
- ▶ Press the **Graphic** control button to see the optical display.

¹⁾ The camera image is not shown for all versions.

Corner view (front/rear)

Applies to vehicles: with top view camera system and corner view (front/rear) mode

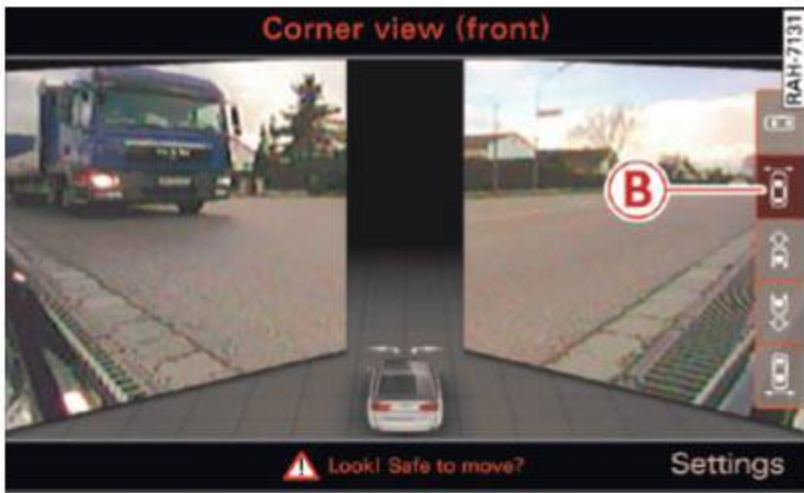

Fig. 142 Infotainment: corner view (front) mode



Fig. 143 Infotainment: corner view (rear) mode

This view can assist you for example, when you are exiting from an area with poor visibility. The area at the front or rear sides of the vehicles is displayed.

- ▶ To see the corner view (front), select the **(B)** symbol with the control knob ⇒ fig. 142.
- ▶ To see the corner view (rear), select the **(E)** symbol with the control knob ⇒ fig. 143.

Front

Applies to vehicles: with top view camera system and front mode

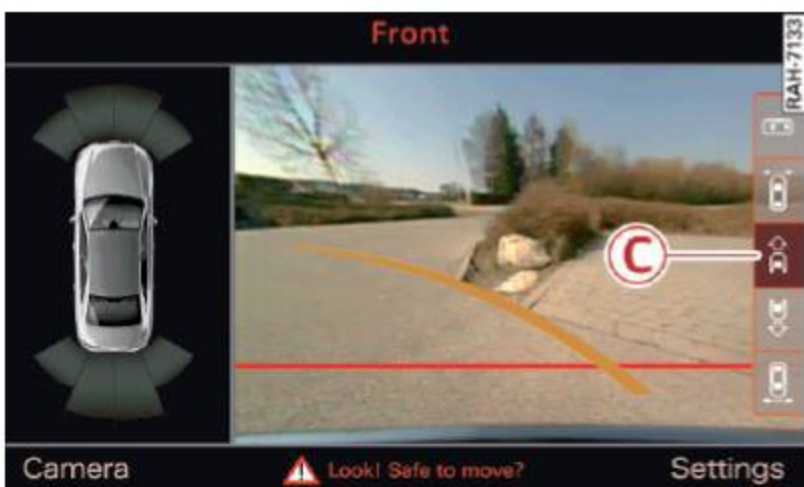

Fig. 144 Infotainment: front mode

This view assists you for example, in using the full maneuvering range in front of the vehicle. The area in front of the vehicle is displayed. The vehicle surroundings are shown in the left area of the display. You can switch between optical display and camera image* ⇒ page 128.

- ▶ Select the **(C)** symbol with the control knob. The orange colored orientation line* denotes the expected direction of travel. Stop the vehicle at the latest when the red orientation line* borders an object ⇒ **(A)** in General information on page 127.

Rear

Applies to vehicles: with top view camera system and rear mode



Fig. 145 Infotainment: rear mode

This view assists you for example, in using the full maneuvering range behind the vehicle. The area behind the vehicle is displayed. The vehicle surroundings are shown in the left area of the display. You can switch between optical display and camera image* ⇒ page 128.

- ▶ Select the **(D)** symbol with the control knob. You can choose between three different views in this mode.
- ▶ To cross park, parallel park, or position the vehicle in front of a trailer, press the **(F)** control button on the unit repeatedly until the symbol for the desired mode is selected.

Cross parking

Applies to vehicles: with top view camera system and rear mode

This view may be used when parking in a garage or in a parking space.



Fig. 146 Infotainment: aiming at a parking space



Fig. 147 Infotainment: aligning the vehicle

Requirement: cross parking is selected
⇒ page 129.

- ▶ The orange colored orientation lines ① show the direction of travel of the vehicle. Turn the steering wheel until the orange orientation lines appear in the parking space ⇒ fig. 146. Use the markings ② to help you estimate the distance from an obstacle. Each marking represents about 3 ft (1 m). The blue area represents an extension of the vehicle's outline by approximately 16 ft (5 m) to the rear.
- ▶ While driving in reverse gear, adjust the steering wheel angle to fit the parking space with the aid of the orange orientation lines ⇒ ⚠ in General information on page 127, ⇒ ! in General information on page 127. ③ marks the rear bumper. Stop the vehicle when the red orientation line ④ borders an obstacle ⇒ ⚠ in General information on page 124.

Parallel parking

Applies to vehicles: with top view camera system and rear mode

This view may be used when parallel parking along the side of a street.



Fig. 148 Infotainment: blue surfaces aligned in the parking space



Fig. 149 Infotainment: contact of the blue curved line with the curb

Parking on the right is described here. It is identical when parking on the left.

If there is an obstacle next to the parking space (such as a wall), refer to information for "Parking next to obstacles" ⇒ page 131.

- ▶ Activate the turn signal.
- ▶ Position your vehicle next to a parked vehicle in front of the desired parking space. The distance to this vehicle should be approximately 3 ft (1 m).
- ▶ Turn the Infotainment on and shift into reverse gear. The parking system is turned on and the *parallel parking* indicator is displayed.
- ▶ Press the ① ⇒ page 126, fig. 136 control button on the Infotainment unit repeatedly until the *cross parking* view is displayed.
- ▶ Back up and align your vehicle so the blue area ② borders on the rear end of the

vehicle or on the parking space line ⇒ ⚠ in *General information on page 127*, ⇒ ⚠ in *General information on page 127*. The blue area represents an extension of the vehicle's outline by approximately 16 ft (5 m) to the rear. The long side of the blue area should be on the curb. The entire blue area must fit into the parking space.

- ▶ With the vehicle stopped, turn the steering wheel to the right as far as it will go.
- ▶ Back into the parking space until the blue curve ⇒ *page 126, fig. 137* touches the curb ⇒ ⚠ in *General information on page 127*, ⇒ ⚠ in *General information on page 127*. Stop the vehicle.
- ▶ With the vehicle stopped, turn the steering wheel to the left as far as it will go.
- ▶ Continue to back into the parking space until the vehicle is parked parallel to the curb ⇒ ⚠ in *General information on page 127*, ⇒ ⚠ in *General information on page 127*. ③ marks the rear bumper. Stop the vehicle, at the latest, when the red orientation line ④ borders an object. Keep an eye on the front of your vehicle while doing this.

Parking next to obstacles

When there is an obstacle (such as a wall) next to the parking space, choose a space with more space on the sides. Position the long side of the blue area so that there is sufficient space from the curb. The area must not be on the curb. You will also need to start turning the steering wheel much earlier. There should be a sufficient amount of space between the curb and the blue curve, and the blue curve ⇒ *page 126, fig. 137* must **not** touch the curb.

i Tips

The left or right orientation lines and surfaces will be displayed, depending on the turn signal being used.

Trailer view

Applies to vehicles: with top view camera system and trailer hitch

This view assists you in positioning the vehicle in front of a trailer.



Fig. 150 Infotainment: rear mode

Requirement: the trailer mode is selected ⇒ *page 129*.

- ▶ Now you can position your vehicle in front of the trailer ⇒ ⚠ in *General information on page 127*, ⇒ ⚠ in *General information on page 127*. The orange colored orientation line denotes the expected path toward the trailer hitch. Use the blue lines to help you estimate the distance to the trailer hitch.

Setting the mode

Applies to vehicles: with top view camera system

- ▶ Select: **CAR** function button > **Car systems** control button > **Driver assist** > **Parking aid** > **Change to front/rear** > **Auto** or **Manual**.

Auto - This view behind the vehicle (**Rear** mode) is displayed automatically when you shift into reverse. This view in front of the vehicle (**Front** mode) is displayed automatically when you shift into the forward gears.

Manual - This view behind the vehicle (**Rear** mode) is always displayed when you turn on the system.

Adjusting the display and the warning tones

Applies to vehicles: with advanced parking system with rear view camera/top view camera system

The display and warning tones can be adjusted in the Infotainment.

- ▶ Select: **CAR** function button > **Car systems** control button > **Driver assist** > **Parking aid**.

Display

On* - optical display is shown for the parking system plus, rear view camera image is shown for parking system plus with rear view camera*.

Off - when the parking system is switched off, only audible signals are given.

Warning tones

Front volume - Volume for the front area

Rear volume - Volume for the rear area

Front frequency - Frequency for the front area

Rear frequency - Frequency for the rear area

Music volume while parking - When the parking system is turned on, the volume of the audio/video source is lowered.

The newly adjusted value is briefly heard from the signal generator.

Tips

- The warning tones can also be adjusted directly from the visual display or the rear view camera* image. Simply press the **Settings** control button.
- Changed settings are activated when the parking system is switched on again.
- The settings are automatically stored and assigned to the remote control key that is in use.

Error messages

Applies to vehicles: with advanced parking system with rear view camera/top view camera system

There is an error in the system if the LED in the **P** button is blinking and you hear a con-

tinuous alarm for a few seconds after switching on the parking system or when the parking system is already activated. If the error is not corrected before you switch off the ignition, the LED in the **P** button will blink the next time you switch on the parking system by shifting into reverse.

If a sensor is faulty, the **P** symbol will appear in front of/behind the vehicle in the Infotainment display. If a rear sensor is faulty, only obstacles that are in the front detection area are shown. If a front sensor is faulty, only obstacles that are in the rear area are shown.

Peripheral cameras*

There is also a system error if:

- the **✖** symbol appears in the display and the corresponding display area is shown in blue. The camera is not working in this area.
- all segments around the vehicles are red or if no segments are displayed.

Drive to your authorized Audi dealer or authorized repair facility immediately to have the malfunction corrected.

Trailer hitch

Applies to vehicles: with advanced parking system with rear view camera/top view camera system

For vehicles using the trailer socket, the parking system rear sensors do not turn on when you shift into reverse gear or when you press the **P** button. This results in the following restrictions:

There is no distance warning for the rear. The front sensors remain activated. The visual display switches to the trailer towing mode. The rear view camera image will not show the orientation lines and the blue surfaces.

Tips

Trailer hitches that are not installed at the factory may cause the parking system to malfunction or they may restrict its function.

HomeLink

Universal remote control

General information

Applies to vehicles: with HomeLink universal remote control

The HomeLink universal remote control can be programmed with hand-held transmitters from existing equipment.

Using the HomeLink universal remote control, you can operate equipment such as garage doors, property gates and house lights from inside your vehicle.

Using the HomeLink universal remote control, you can replace up to three separate hand-held transmitters for equipment on your property with just one universal remote control. Most of these transmitters are used to operate garage doors and property gates. The individual transmitters are programmed at the front bumper. That is where the control module is located.

The transmitters must be programmed first in order to operate systems using the HomeLink universal remote control.

WARNING

- Never use the HomeLink transmitter with any garage door opener that does not have the safety stop and reverse feature as required by federal safety standards. This includes any garage door opener model manufactured before April 1, 1982.
- A garage door opener which cannot detect an object, signaling the door to stop and reverse does not meet current federal safety standards. Using a garage door opener without these features increases risk of serious injury or death.
- For safety reasons never release the parking brake or start the engine while anyone is standing in front of the vehicle.
- A garage door or an estate gate may sometimes be set in motion when the

HomeLink remote control is being programmed. If the device is repeatedly activated, this can overstrain motor and damage its electrical components - an overheated motor is a fire hazard!

- To avoid possible injuries or property damage, please always make absolutely certain that no persons or objects are located in the range of motion of any equipment being operated.

Tips

- If you would like additional information on the HomeLink Universal Transceiver, HomeLink compatible products, or to purchase other accessories such as the HomeLink Lighting Package, please contact HomeLink at 1-800-355-3515 or on the Internet at www.homelink.com.
- For Declaration of Compliance to United States FCC and Industry Canada regulations ⇒ *page 295*.



Operation

Applies to vehicles: with HomeLink



Fig. 151 Control unit in the headliner

Requirement: The buttons must be programmed ⇒ *page 134*.

- ▶ Press the programmed button ⇒  in *General information on page 133* to open the garage door. The light  will blink or turn on.
- ▶ Press the button again to close the garage door ⇒  in *General information on page 133*.

i Tips

To open the garage door, press the button, but do not press it for longer ten seconds or the HomeLink module will switch to programming mode.

Programming transmitters

Applies to vehicles: with HomeLink



Fig. 152 Left front area of the bumper

You can program both fixed code and rolling code systems using these instructions.

Programming a button

- ▶ Make sure your vehicle is within operating range of the remote controlled garage door opener.
- ▶ Set the parking brake ⇒  in *General information on page 133*.
- ▶ Switch the ignition on. Do not start the engine!
- ▶ There are two ways to program a button: press the button that you would like to program. The MMI will display instructions to guide you through the programming. Or
- ▶ Select: **CAR** function button > **Car systems control button** > **Vehicle settings** > **Garage door opener** > **Program garage door opener**.
- ▶ Select the button that you would like to program.
- ▶ Follow the instructions in the MMI.
- ▶ If the garage door opening must also be synchronized with the HomeLink module, refer to the owner's manual for the garage door opener.

Erasing the button programming

- ▶ Select: **CAR** function button > **Car systems function key** > **Vehicle settings** > **Garage door opener** > **Clear program settings** > **Yes**.

Displaying the version/status/country code

- ▶ Select: **CAR** function button > **Car systems control button** > **Vehicle settings** > **Garage door opener** > **Version information**.

Programming a button

The required distance between the handheld transmitter and the HomeLink module in the bumper depends on the system that you are programming. When programming a new device, keep the button pressed for at least 15 seconds before trying again with the transmitter in a different position.

Each of the buttons can be reprogrammed individually. The procedure is the same as for initial programming. ⇒ *page 134, Programming a button*.

Erasing the button programming

Individual buttons can be reprogrammed. Follow the same steps used when first programming the button.

If you would like to erase all programmed buttons at the same time, select Erase button programming.

i Tips

- To ensure your safety, erasing the programmed HomeLink buttons before selling the vehicle is recommended.
- Depending on the model of the garage door opener, you may need to release the button on the remote and press it again when programming.

Driving Safely

General notes

Safe driving habits

Please remember - safety first!

This chapter contains important information, tips, instructions and warnings that you need to read and observe for your own safety, the safety of your passengers and others. We have summarized here what you need to know about safety belts, airbags, child restraints as well as child safety. Your safety is for us *priority number 1*. Always observe the information and warnings in this section - for your own safety as well as that of your passengers.

The information in this section applies to all model versions of your vehicle. Some of the features described in this sections may be standard equipment on some models, or may be optional equipment on others. If you are not sure, ask your authorized Audi dealer.

WARNING

- Always make sure that you follow the instructions and heed the WARNINGS in this Manual. It is in your interest and in the interest of your passengers.
- Always keep the complete Owner's Literature in your Audi when you lend or sell your vehicle so that this important information will always be available to the driver and passengers.
- Always keep the Owner's literature handy so that you can find it easily if you have questions.

Safety equipment

The safety features are part of the occupant restraint system and work together to help reduce the risk of injury in a wide variety of accident situations.

Your safety and the safety of your passengers should not be left to chance. Advances in technology have made a variety of features available to help reduce the risk of injury in an

accident. The following is a list of just a few of the safety features in your Audi:

- sophisticated safety belts for driver and all passenger seating positions,
- safety belt pretensioners,
- safety belt force limiters for the front seats,
- safety belt height adjustment systems for the front seats,
- front airbags,
- knee airbags for the front seats
- side airbags in the front seats and outer rear seats,
- side curtain airbags,
- special LATCH anchorages for child restraints,
- head restraints for each seating position,
- adjustable steering column.

These individual safety features, can work together as a system to help protect you and your passengers in a wide range of accidents. These features cannot work as a system if they are not always correctly adjusted and correctly used.

Safety is everybody's responsibility!

Important things to do before driving

Safety is everybody's job! Vehicle and occupant safety always depends on the informed and careful driver.

For your safety and the safety of your passengers, **before driving always:**

- ▶ Make sure that all lights and signals are operating correctly.
- ▶ Make sure that the tire pressure is correct.
- ▶ Make sure that all windows are clean and afford good visibility to the outside.
- ▶ Secure all luggage and other items carefully ⇒ page 70, ⇒ page 75.
- ▶ Make sure that nothing can interfere with the pedals.
- ▶ Adjust front seat, head restraint and mirrors correctly for your height.
- ▶ Instruct passengers to adjust the head restraints according to their height. ▶

- ▶ Make sure to use the right child restraint correctly to protect children ⇒ *page 177, Child Safety.*
- ▶ Sit properly in your seat and make sure that your passengers do the same ⇒ *page 58, General recommendations.*
- ▶ Fasten your safety belt and wear it properly. Also instruct your passengers to fasten their safety belts properly ⇒ *page 145.*

What impairs driving safety?

Safe driving is directly related to the condition of the vehicle, the driver as well as the driver's ability to concentrate on the road without being distracted.

The driver is responsible for the safety of the vehicle and all of its occupants. If your ability to drive is impaired, safety risks for everybody in the vehicle increase and you also become a hazard to everyone else on the road ⇒ ⚠.

Therefore:

- ▶ Do not let yourself be distracted by passengers or by using a cellular telephone.
- ▶ NEVER drive when your driving ability is impaired (by medications, alcohol, drugs, etc.).
- ▶ Observe all traffic laws, rules of the road and speed limits and plain common sense.
- ▶ ALWAYS adjust your speed to road, traffic and weather conditions.
- ▶ Take frequent breaks on long trips. Do not drive for more than two hours at a stretch.
- ▶ Do NOT drive when you are tired, under pressure or when you are stressed.

⚠ WARNING

Impaired driving safety increases the risk of serious personal injury and death whenever a vehicle is being used.

Proper occupant seating positions

Proper seating position for the driver

The proper driver seating position is important for safe, relaxed driving.

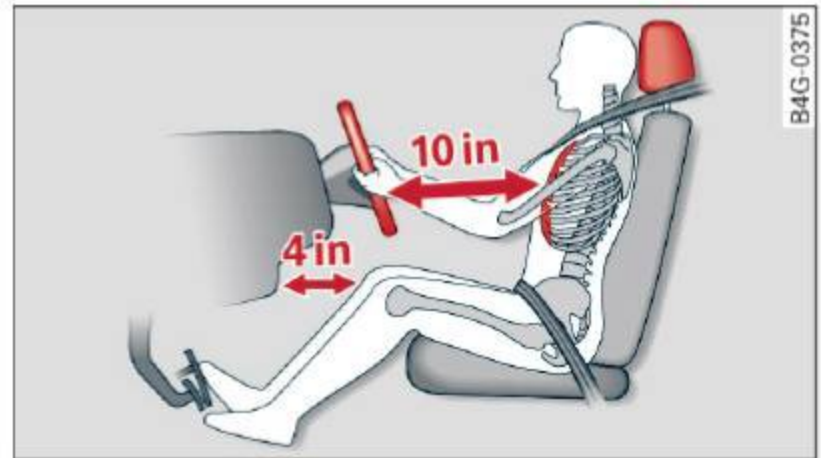

Fig. 153 Correct seating position

For your own safety and to reduce the risk of injury in the event of an accident, we recommend that you adjust the driver's seat to the following position:

- ▶ Adjust the driver's seat so that you can easily push the pedals all the way to the floor while keeping your knee(s) slightly bent ⇒ ⚠.
- ▶ Adjust the angle of the seatback so that it is in an upright position so that your back comes in full contact with it when you drive.
- ▶ Adjust the steering wheel so that there is a distance of at least 10 inches (25 cm) between the steering wheel and your breast bone ⇒ *fig. 153*. If not possible, see your authorized Audi dealership about adaptive equipment.
- ▶ Adjust the steering wheel so that the steering wheel and airbag cover points at your chest and not at your face.
- ▶ Grasp the top of the steering wheel with your elbow(s) slightly bent.
- ▶ Adjust the head restraint so the upper edge is as even as possible with the top of your head. If that is not possible, try to adjust the head restraint so that it is as close to this position as possible.
- ▶ Fasten and wear safety belts correctly ⇒ *page 148.*

- ▶ Always keep both feet in the footwell so that you are in control of the vehicle at all times.

For detailed information on how to adjust the driver's seat, see ⇒ *page 59*.

WARNING

Drivers who are unbelted, out of position or too close to the airbag can be seriously injured by an airbag as it unfolds. To help reduce the risk of serious personal injury:

- Always adjust the driver's seat and the steering wheel so that there are at least 10 inches (25 cm) between your breastbone and the steering wheel.
- Always adjust the driver's seat and the steering wheel so that there are at least 4 inches (10 cm) between the knees and the lower part of the instrument panel.
- Always hold the steering wheel on the outside of the steering wheel rim with your hands at the 9 o'clock and 3 o'clock positions to help reduce the risk of personal injury if the driver's airbag inflates.
- Never hold the steering wheel at the 12 o'clock position or with your hands at other positions inside the steering wheel rim or on the steering wheel hub. Holding the steering wheel the wrong way can cause serious injuries to the hands, arms and head if the driver's airbag inflates.
- Pointing the steering wheel toward your face decreases the ability of the supplemental driver's airbag to protect you in a collision.
- Always sit in an upright position and never lean against or place any part of your body too close to the area where the airbags are located.
- Before driving, always adjust the front seats and head restraints properly and make sure that all passengers are properly restrained.
- Never adjust the seats while the vehicle is moving. Your seat may move unexpect-

edly and you could lose control of the vehicle.

- Never drive with the backrest reclined or tilted far back! The farther the backrests are tilted back, the greater the risk of injury due to incorrect positioning of the safety belt and improper seating position.
- Children must always ride in child seats ⇒ *page 177*. Special precautions apply when installing a child seat on the front passenger seat ⇒ *page 153*.

Proper seating position for the front passenger

The proper front passenger seating position is important for safe, relaxed driving.

For your own safety and to reduce the risk of injury in the event of an accident, we recommend that you adjust the seat for the front passenger to the following position:

- ▶ Adjust the angle of the seatback so that it is in an upright position and your back comes in full contact with it whenever the vehicle is moving.
- ▶ Adjust the head restraint so the upper edge is as even as possible with the top of your head. If that is not possible, try to adjust the head restraint so that it is as close to this position as possible ⇒ *page 139*.
- ▶ Keep both feet flat on the floor in front of the front passenger seat.
- ▶ Fasten and wear safety belts correctly ⇒ *page 148*.

For detailed information on how to adjust the front passenger's seat, see ⇒ *page 58*.

WARNING

Front seat passengers who are unbelted, out of position or too close to the airbag can be seriously injured or killed by the airbag as it unfolds. To help reduce the risk of serious personal injury:

- Passengers must always sit in an upright position and never lean against or place any part of their body too close to the area where the airbags are located.
- Passengers who are unbelted, out of position or too close to the airbag can be seriously injured by an airbag as it unfolds with great force in the blink of an eye.
- Always make sure that there are at least 10 inches (25 cm) between the front passenger's breastbone and the instrument panel.
- Always make sure that there are at least 4 inches (10 cm) between the front passenger's knees and the lower part of the instrument panel.
- Each passenger must always sit on a seat of their own and properly fasten and wear the safety belt belonging to that seat.
- Before driving, always adjust the front passenger seat and head restraint properly.
- Always keep your feet on the floor in front of the seat. Never rest them on the seat, instrument panel, out of the window, etc. The airbag system and safety belt will not be able to protect you properly and can even increase the risk of injury in a crash.
- Never drive with the backrest reclined or tilted far back! The farther the backrests are tilted back, the greater the risk of injury due to incorrect positioning of the safety belt and improper seating position.
- Children must always ride in child seats ⇒ *page 177*. Special precautions apply when installing a child seat on the front passenger seat ⇒ *page 153*.

Proper seating positions for passengers in rear seats

Rear seat passengers must sit upright with both feet on the floor consistent with their physical size and be properly restrained whenever the vehicle is in use.

To reduce the risk of injury caused by an incorrect seating position in the event of a sudden braking maneuver or an accident, your passengers on the rear bench seat must always observe the following:

- ▶ Adjust the head restraint so the upper edge is as even as possible with the top of your head. If that is not possible, try to adjust the head restraint so that it is as close to this position as possible ⇒ *page 139*.
- ▶ Keep both feet flat in the footwell in front of the rear seat.
- ▶ Fasten and wear safety belts properly ⇒ *page 148*.
- ▶ Make sure that children are always properly restrained in a child restraint that is appropriate for their size and age ⇒ *page 177*.

WARNING

Passengers who are improperly seated on the rear seat can be seriously injured in a crash.

- Each passenger must always sit on a seat of their own and properly fasten and wear the safety belt belonging to that seat.
- Safety belts only offer maximum protection when the safety belts are properly positioned on the body and securely latched. By not sitting upright, a rear seat passenger increases the risk of personal injury from improperly positioned safety belts!
- Always adjust the head restraint properly so that it can give maximum protection.

Proper adjustment of head restraints

Correctly adjusted head restraints are an important part of your vehicle's occupant restraint system and can help to reduce the risk of injuries in accident situations.

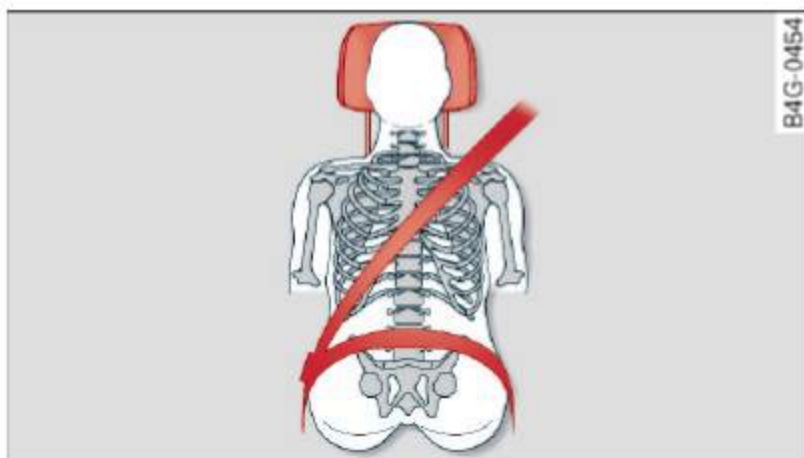

Fig. 154 Head restraint: viewed from the front

The head restraints must be correctly adjusted to achieve the best protection.

- For adjustable head restraints: adjust the head restraint so the upper edge is as even as possible with the top of your head. If that is not possible, try to adjust the head restraint so that it is as close to this position as possible. ⇒ fig. 154.

Adjusting head restraints ⇒ page 65.

Crash - active head restraints

In the event of a rear-end collision, it is possible that the crash-active head restraints on the driver's seat and front passenger's seat¹⁾ are triggered. On head restraints that have been triggered, the padding protrudes forwards by several centimeters. Drive the vehicle to your authorized Audi dealer without delay and have the function of the active head restraints restored.

WARNING

Driving without head restraints or with head restraints that are not properly adjusted increases the risk of serious or fatal neck injury dramatically. To help reduce the risk of injury:

- Always drive with the head restraints in place and properly adjusted.
- Every person in the vehicle must have a properly adjusted head restraint.
- Always make sure each person in the vehicle properly adjusts their head restraint. Adjust the head restraint so the upper edge is as even as possible with the top of your head. If that is not possible, try to adjust the head restraint so that it is as close to this position as possible.
- Never attempt to adjust head restraint while driving. If you have driven off and must adjust the driver headrest for any reason, first stop the vehicle safely before attempting to adjust the head restraint.
- Children must always be properly restrained in a child restraint that is appropriate for their age and size ⇒ page 177.

Examples of improper seating positions

The occupant restraint system can only reduce the risk of injury if vehicle occupants are properly seated.

Improper seating positions can cause serious injury or death. Safety belts can only work when they are properly positioned on the body. Improper seating positions reduce the effectiveness of safety belts and will even increase the risk of injury and death by moving the safety belt to critical areas of the body. Improper seating positions also increase the risk of serious injury and death when an airbag deploys and strikes an occupant who is not in the proper seating position. A driver is responsible for the safety of all vehicle occupants and especially for children. Therefore:

- Never allow anyone to assume an incorrect seating position when the vehicle is being used ⇒ .

¹⁾ Vehicles with reclining rear seat: This function is not available for the front passenger's seat.

The following bulletins list only some sample positions that will increase the risk of serious injury and death. Our hope is that these examples will make you more aware of seating positions that are dangerous.

Therefore, whenever the vehicle is moving:

- never stand up in the vehicle
- never stand on the seats
- never kneel on the seats
- never ride with the seatback reclined
- never lie down on the rear seat
- never lean up against the instrument panel
- never sit on the edge of the seat
- never sit sideways
- never lean out the window
- never put your feet out the window
- never put your feet on the instrument panel
- never rest your feet on the seat cushion or back of the seat
- never ride in the footwell
- never ride in the cargo area

 **WARNING**

Improper seating positions increase the risk of serious personal injury and death whenever a vehicle is being used.

- Always make sure that all vehicle occupants stay in a proper seating position and are properly restrained whenever the vehicle is being used.

Driver and passenger side footwell

Important safety instructions

 **WARNING**

Always make sure that the knee airbag can inflate without interference. Objects between yourself and the airbag can increase the risk of injury in an accident by interfering with the way the airbag deploys or by being pushed into you as the airbag deploys.

- No persons (children) or animals should ride in the footwell in front of the passenger seat. If the airbag deploys, this can result in serious or fatal injuries.
- No objects of any kind should be carried in the footwell area in front of the driver's or passenger's seat. Bulky objects (shopping bags, for example) can hamper or prevent proper deployment of the airbag. Small objects can be thrown through the vehicle if the airbag deploys and injure you or your passengers.

Pedal area

Pedals

The pedals must always be free to move and must never be interfered with by a floor mat or any other object.

Make sure that all pedals move freely without interference and that nothing prevents them from returning to their original positions.

Only use floor mats that leave the pedal area free and can be secured with floor mat fasteners.

If a brake circuit fails, increased brake pedal travel is required to bring the vehicle to a full stop.

 **WARNING**

Pedals that cannot move freely can cause loss of vehicle control and increase the risk of serious injury.

- Never place any objects in the driver's footwell. An object could get into the pedal area and interfere with pedal function. In case of sudden braking or an accident, you would not be able to brake or accelerate!
- Always make sure that nothing can fall or move into the driver's footwell.

Floor mats on the driver side

Always use floor mats that can be securely attached to the floor mat fasteners and do not interfere with the free movement of the pedals.

- ▶ Make sure that the floor mats are properly secured and cannot move and interfere with the pedals ⇒ .

Use only floor mats that leave the pedal area unobstructed and that are firmly secured so that they cannot slip out of position. You can obtain suitable floor mats from your authorized Audi Dealer.

Floor mat fasteners are installed in your Audi.

Floor mats used in your vehicle must be attached to these fasteners. Properly securing the floor mats will prevent them from sliding into positions that could interfere with the pedals or impair safe operation of your vehicle in other ways.

WARNING

Pedals that cannot move freely can result in a loss of vehicle control and increase the risk of serious personal injury.

- Always make sure that floor mats are properly secured.
- Never place or install floor mats or other floor coverings in the vehicle that cannot be properly secured in place to prevent them from slipping and interfering with the pedals or the ability to control the vehicle.
- Never place or install floor mats or other floor coverings on top of already installed floor mats. Additional floor mats and other coverings will reduce the size of the pedal area and interfere with the pedals.
- Always properly reinstall and secure floor mats that have been taken out for cleaning.
- Always make sure that objects cannot fall into the driver footwell while the vehicle is moving. Objects can become

trapped under the brake pedal and accelerator pedal causing a loss of vehicle control.

Stowing luggage

Loading the luggage compartment

All luggage and other objects must be properly stowed and secured in the luggage compartment.

Loose items in the luggage compartment can shift suddenly, changing vehicle handling characteristics. Loose items can also increase the risk of serious personal injury in a sudden vehicle maneuver or in a collision.

- ▶ Distribute the load evenly in the luggage compartment.
- ▶ Always place and properly secure heavy items in the luggage compartment as far forward as possible.
- ▶ Secure luggage items using the tie-downs provided ⇒ *page 70, Luggage compartment*.

WARNING

Improperly stored luggage or other items can fly through the vehicle causing serious personal injury in the event of hard braking or an accident. To help reduce the risk of serious personal injury:

- Always put objects, for example, luggage or other heavy items in the luggage compartment.
- Always secure objects in the luggage compartment using the tie-down hooks and suitable straps.

WARNING

Heavy loads will influence the way your vehicle handles. To help reduce the risk of a loss of control leading to serious personal injury:

- Always keep in mind when transporting heavy objects, that a change in the center of gravity can also cause changes in vehicle handling:

- Always distribute the load as evenly as possible.
- Place heavy objects as far forward in the luggage compartment as possible.
- Never exceed the Gross Axle Weight Rating or the Gross Vehicle Weight Rating specified on the safety compliance sticker on the left door jamb. Exceeding permissible weight standards can cause the vehicle to slide and handle differently.
- Please observe information on safe driving ⇒ *page 135*.

WARNING

- To help prevent poisonous exhaust gas from being drawn into the vehicle, always keep the rear lid closed while driving.
- Never transport objects larger than those fitting completely into the luggage area because the rear lid cannot be fully closed.
 - If you absolutely must drive with the rear lid open, observe the following notes to reduce the risk of poisoning:
 - Close all windows,
 - Close the power roof,
 - Open all air outlets in the instrument panel,
 - Switch off the air recirculation,
 - Set the fresh air fan to the highest speed.

WARNING

- Always make sure that the doors, all windows, the power roof and the rear lid are securely closed and locked to reduce the risk of injury when the vehicle is not being used.
- After closing the rear lid, always make sure that it is properly closed and locked.
 - Never leave your vehicle unattended especially with the rear lid left open. A child could crawl into the vehicle through the luggage compartment and close the rear lid becoming trapped and unable to get out. Being trapped in a vehicle can lead to serious personal injury.

- Never let children play in or around the vehicle.
- Never let passengers ride in the luggage compartment. Vehicle occupants must always be properly restrained in one of the vehicle's seating positions.

Tips

- Air circulation helps to reduce window fogging. Stale air escapes to the outside through vents in the trim panel, on the left side of the luggage compartment. Be sure to keep these slots free and open.
- The tire pressure must correspond to the load. The tire pressure is shown on the tire pressure label. The tire pressure label is located on the driver's side B-pillar. The tire pressure label lists the recommended cold tire inflation pressures for the vehicle at its maximum capacity weight and the tires that were on your vehicle at the time it was manufactured. For recommended tire pressures for normal load conditions, please see chapter ⇒ *page 252*.

Tie-downs

The luggage compartment is equipped with four tie-downs to secure luggage and other items.

Use the tie-downs to secure your cargo properly ⇒ *page 141, Loading the luggage compartment*.

In a collision, the laws of physics mean that even smaller items that are loose in the vehicle will become heavy missiles that can cause serious injury. Items in the vehicle possess energy which vary with vehicle speed and the weight of the item. Vehicle speed is the most significant factor.

For example, in a frontal collision at a speed of 30 mph (48 km/h), the forces acting on a 10-lb (4.5 kg) object are about 20 times the normal weight of the item. This means that the weight of the item would suddenly be

about 200 lbs. (90 kg). You can imagine the injuries that a 200 lbs. (90 kg) item flying freely through the passenger compartment could cause in a collision like this.

 **WARNING**

Weak, damaged or improper straps used to secure items to tie-downs can fail during hard braking or in a collision and cause serious personal injury.

- Always use suitable mounting straps and properly secure items to the tie-downs in the luggage compartment to help prevent items from shifting or flying forward as dangerous missiles.
- Never attach a child safety seat tether strap to a tie-down.

Reporting Safety Defects

Applicable to U.S.A.

If you believe that your vehicle has a defect which could cause a crash or could cause injury or death, you should immediately inform the National Highway Traffic Safety Administration (NHTSA) in addition to notifying Audi of America, Inc.

If NHTSA receives similar complaints, it may open an investigation, and if it finds that a safety defect exists in a group of vehicles, it may order a recall and remedy campaign. However, NHTSA cannot become involved in individual problems

between you, your dealer, or Audi of America, Inc.

To contact the NHTSA, you may either call:

Tel.: 1-888-327-4236 (TTY: 1-800-424-9153) or 1-800-424-9393

or you may write to:

NHTSA
U.S. Department of Transportation
1200 New Jersey Ave., S.E.
West Building
Washington, DC 20590

You can also obtain other information about motor vehicle safety from:

<http://www.safercar.gov>

Applicable to Canada

If you live in Canada and you believe that your vehicle has a defect that could cause a crash, injury or death, you should immediately inform Transport Canada, Defect Investigations and Recalls. You should also notify Volkswagen Group Canada, Inc. ▶

Canadian customers who wish to report a safety-related defect to Transport Canada, Defect Investigations and Recalls, may either call Transport Canada toll-free at:

Tel.: 1-800-333-0510 or

Tel.: 1-819-994-3328 (Ottawa region and from other countries)

TTY for hearing impaired: Tel.: 1-888-675-6863

or contact Transport Canada by mail at:

Transport Canada
Motor Vehicle Safety Investigations Laboratory
80 Noel Street
Gatineau, QC
J8Z 0A1

For additional road safety information, please visit the Road Safety website at:

<http://www.tc.gc.ca/eng/roadsafety/menu.htm>

Safety belts

General notes

Always wear safety belts!

Wearing safety belts correctly saves lives!

This chapter explains why safety belts are necessary, how they work and how to adjust and wear them correctly.

- ▶ Read all the information that follows and heed all of the instructions and WARNINGS.

WARNING

Not wearing safety belts or wearing them improperly increases the risk of serious personal injury and death.

- Safety belts are the single most effective means available to reduce the risk of serious injury and death in automobile accidents. For your protection and that of your passengers, always correctly wear safety belts when the vehicle is moving.
- Pregnant women, injured, or physically impaired persons must also use safety belts. Like all vehicle occupants, they are more likely to be seriously injured if they do not wear safety belts. The best way to protect a fetus is to protect the mother - throughout the entire pregnancy.

Number of seats

Your Audi has a total of five seating positions: two in the front and three in the rear. In some vehicles, there are four seating positions: two in the front and two in the rear. Each seating position has a safety belt.

WARNING

Not wearing safety belts or wearing them improperly increases the risk of serious personal injury and death.

- Never strap more than one person, including small children, into any belt. It is especially dangerous to place a safety belt over a child sitting on your lap.

- Never let more people ride in the vehicle than there are safety belts available.
- Be sure everyone riding in the vehicle is properly restrained with a separate safety belt or child restraint.

Safety belt warning light

Your vehicle has a warning system for the driver and front seat passenger to remind you about the importance of buckling-up.



Fig. 155 Safety belt warning light in the instrument cluster - enlarged

Before driving off, always:

- ▶ Fasten your safety belt and make sure you are wearing it properly.
- ▶ Make sure that your passengers also buckle up and properly wear their safety belts.
- ▶ Protect children with a child restraint system appropriate for the size and age.

The warning light  in the instrument cluster lights up when the ignition is on as a reminder to fasten the safety belts. In addition, you will hear a warning tone for a certain period of time.

Fasten your safety belt and make sure that your passengers also properly put on their safety belts.

WARNING

- Safety belts are the single most effective means available to reduce the risk of serious injury and death in automobile accidents. For your protection and that of your passengers, always correctly wear safety belts when the vehicle is moving.

- Failure to pay attention to the warning light that come on, could lead to personal injury.

Why safety belts?

Frontal collisions and the law of physics

Frontal crashes create very strong forces for people riding in vehicles.

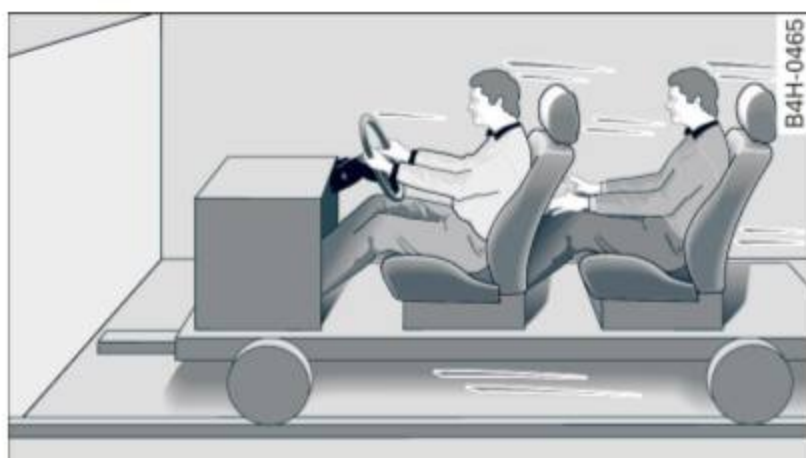

Fig. 156 Unbelted occupants in a vehicle heading for a wall



Fig. 157 The vehicle crashes into the wall

The physical principles are simple. Both the vehicle and the passengers possess energy which varies with vehicle speed and body weight. Engineers call this energy “kinetic energy.”

The higher the speed of the vehicle and the greater the vehicle's weight, the more energy that has to be “absorbed” in the crash.

Vehicle speed is the most significant factor. If the speed doubles from 15 to 30 mph (25 to 50 km/h), the energy increases 4 times!

Because the passengers of this vehicle are not using safety belts ⇒ *fig. 156*, they will keep moving at the same speed the vehicle was moving just before the crash, until something stops them - here, the wall ⇒ *fig. 157*.

The same principles apply to people sitting in a vehicle that is involved in a frontal collision. Even at city speeds of 20 to 30 mph (30 to 50 km/h), the forces acting on the body can reach one ton (2,000 lbs, or 1,000 kg) or more. At greater speeds, these forces are even higher.

People who do not use safety belts are also not attached to their vehicle. In a frontal collision they will also keep moving forward at the speed their vehicle was travelling just before the crash. Of course, the laws of physics don't just apply to frontal collisions, they determine what happens in all kinds of accidents and collisions.

What happens to occupants not wearing safety belts?

In crashes unbelted occupants cannot stop themselves from flying forward and being injured or killed. Always wear your safety belts!



Fig. 158 A driver not wearing a safety belt is violently thrown forward



Fig. 159 A rear passenger not wearing a safety belt will fly forward and strike the driver

Unbelted occupants are not able to resist the tremendous forces of impact by holding tight or bracing themselves. Without the benefit of safety restraint systems, the unrestrained

occupant will slam violently into the steering wheel, instrument panel, windshield, or whatever else is in the way ⇒ *fig. 158*. This impact with the vehicle interior has all the energy they had just before the crash.

Never rely on airbags alone for protection. Even when they deploy, airbags provide only additional protection. Airbags are not supposed to deploy in all kinds of accidents. Although your Audi is equipped with airbags, all vehicle occupants, including the driver, must wear safety belts correctly in order to minimize the risk of severe injury or death in a crash.

Remember too, that airbags will deploy only once and that your safety belts are always there to offer protection in those accidents in which airbags are not supposed to deploy or when they have already deployed. Unbelted occupants can also be thrown out of the vehicle where even more severe or fatal injuries can occur.

It is also important for the rear passengers to wear safety belts correctly. Unbelted passengers in the rear seats endanger not only themselves but also the driver and other passengers ⇒ *fig. 159*. In a frontal collision they will be thrown forward violently, where they can hit and injure the driver and/or front seat passenger.

Safety belts protect

People think it's possible to use the hands to brace the body in a minor collision. It's simply not true!



Fig. 160 Driver is correctly restrained in a sudden braking maneuver

Safety belts used properly can make a big difference. Safety belts help to keep passengers in their seats, gradually reduce energy levels applied to the body in an accident, and help prevent the uncontrolled movement that can cause serious injuries. In addition, safety belts reduce the danger of being thrown out of the vehicle.

Safety belts attach passengers to the car and give them the benefit of being slowed down more gently or “softly” through the “give” in the safety belts, crush zones and other safety features engineered into today’s vehicles. By “absorbing” the kinetic energy over a longer period of time, the safety belts make the forces on the body more “tolerable” and less likely to cause injury.

Although these examples are based on a frontal collision, safety belts can also substantially reduce the risk of injury in other kinds of crashes. So, whether you’re on a long trip or just going to the corner store, always buckle up and make sure others do, too. Accident statistics show that vehicle occupants properly wearing safety belts have a lower risk of being injured and a much better chance of surviving an accident. Properly using safety belts also greatly increases the ability of the supplemental airbags to do their job in a collision. For this reason, wearing a safety belt is legally required in most countries including much of the United States and Canada.

Although your Audi is equipped with airbags, you still have to wear the safety belts provided. Front airbags, for example, are activated only in some frontal collisions. The front airbags are not activated in all frontal collisions, in side and rear collisions, in roll overs or in cases where there is not enough deceleration through impact to the front of the vehicle. The same goes for the other airbag systems in your Audi. So, always wear your safety belt and make sure everybody in your vehicle is properly restrained!

Important safety instructions about safety belts

Safety belts must always be correctly positioned across the strongest bones of your body.

- ▶ Always wear safety belts as illustrated and described in this chapter.
- ▶ Make sure that your safety belts are always ready for use and are not damaged.

WARNING

Not wearing safety belts or wearing them improperly increases the risk of serious personal injury and death. Safety belts can work only when used correctly.

- Always fasten your safety belts correctly before driving off and make sure all passengers are correctly restrained.
- For maximum protection, safety belts must always be positioned properly on the body.
- Never strap more than one person, including small children, into any belt.
- Never place a safety belt over a child sitting on your lap.
- Always keep feet in the footwell in front of the seat while the vehicle is being driven.
- Never let any person ride with their feet on the instrument panel or sticking out the window or on the seat.
- Never remove a safety belt while the vehicle is moving. Doing so will increase your risk of being injured or killed.
- Never wear belts twisted.
- Never wear belts over rigid or breakable objects in or on your clothing, such as eye glasses, pens, keys, etc., as these may cause injury.
- Never allow safety belts to become damaged by being caught in door or seat hardware.
- Do not wear the shoulder part of the belt under your arm or otherwise out of position.

- Several layers of heavy clothing may interfere with correct positioning of belts and reduce the overall effectiveness of the system.
- Always keep belt buckles free of anything that may prevent the buckle from latching securely.
- Never use comfort clips or devices that create slack in the shoulder belt. However, special clips may be required for the proper use of some child restraint systems.
- Torn or frayed safety belts can tear, and damaged belt hardware can break in an accident. Inspect belts regularly. If webbing, bindings, buckles, or retractors are damaged, have belts replaced by an authorized Audi dealer or qualified workshop.
- Safety belts that have been worn and loaded in an accident must be replaced with the correct replacement safety belt by an authorized Audi dealer. Replacement may be necessary even if damage cannot be clearly seen. Anchorages that were loaded must also be inspected.
- Never remove, modify, disassemble, or try to repair the safety belts yourself.
- Always keep the belts clean. Dirty belts may not work properly and can impair the function of the inertia reel ⇒ *table Cleaning interior on page 218.*

Safety belts

Fastening safety belts

Safety first - everybody buckle up!



Fig. 161 Belt buckle and tongue on the driver's seat

To provide maximum protection, safety belts must always be positioned correctly on the wearer's body.

- ▶ Adjust the front seat and head restraint properly ⇒ *page 58, General recommendations.*
- ▶ Hold the belt by the tongue and pull it evenly across the chest and pelvis ⇒ .
- ▶ Insert the tongue into the correct buckle of your seat until you hear it latch securely ⇒ *fig. 161.*
- ▶ Pull on the belt to make sure that it is securely latched in the buckle.

Automatic safety belt retractors

Every safety belt is equipped with an automatic belt retractor on the shoulder belt. This feature locks the belt when the belt is pulled out fast, during hard braking and in an accident. The belt may also lock when you drive up or down a steep hill or through a sharp curve. During normal driving the belt lets you move freely.

Safety belt pretensioners

The safety belts are equipped with a belt pretensioner that helps to tighten the safety belt and remove slack when the pretensioner is activated ⇒ *page 151.* The function of the pretensioner is monitored by a warning light ⇒ *page 18.*

Switchable locking feature

Every safety belt except the one on the driver seat is equipped with a switchable locking feature that **must** be used when the safety belt is used to attach a child seat. Be sure to read the important information about this feature ⇒ *page 187.*

WARNING

Improperly positioned safety belts can cause serious injury in an accident ⇒ *page 149, Safety belt position.*

- Safety belts offer optimum protection only when the seatback is upright and belts are properly positioned on the body.

- Never attach the safety belt to the buckle for another seat. Attaching the belt to the wrong buckle will reduce safety belt effectiveness and can cause serious personal injury.
- A passenger who is not properly restrained can be seriously injured by the safety belt itself when it moves from the stronger parts of the body into critical areas like the abdomen.
- Always lock the convertible locking retractor when you are securing a child seat in the vehicle ⇒ *page 189.*

Tips

For information on safety belt pretensioners, refer to ⇒ *page 151.*

Safety belt position

Correct belt position is the key to getting maximum protection from safety belts.

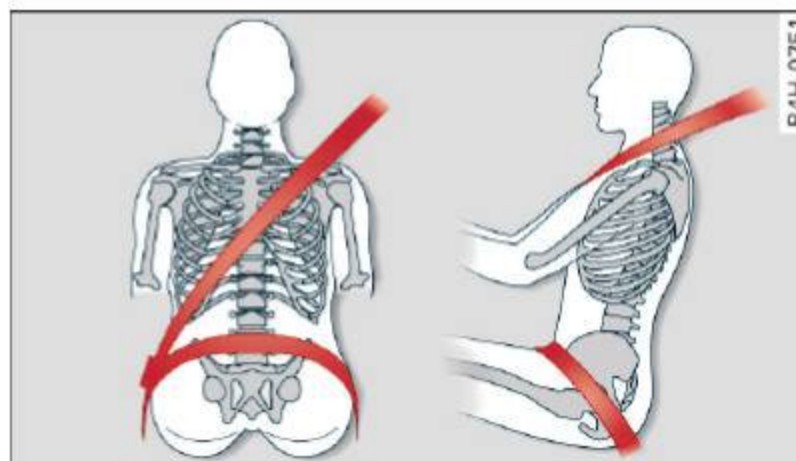

Fig. 162 Safety belt position

Use the height adjustment to change the position of the shoulder belt of the front safety belts.

WARNING

Improperly positioned safety belts can cause serious personal injury in an accident.

- The shoulder belt should lie as close to the center of the collar bone as possible and should fit well on the body. Hold the belt above the latch tongue and pull it evenly across the chest so that it sits as low as possible on the pelvis and there is no pressure on the abdomen. The belt

should always fit snugly ⇒ *fig. 162*. Pull on the belt to tighten if necessary.

- A loose-fitting safety belt can cause serious injuries by shifting its position on your body from the strong bones to more vulnerable, soft tissue and cause serious injury.
- Always read and heed all WARNINGS and other important information ⇒ *page 148*.

Pregnant women must also be correctly restrained

The best way to protect the fetus is to make sure that expectant mothers always wear safety belts correctly - throughout the pregnancy.



Fig. 163 Safety belt position during pregnancy

To provide maximum protection, safety belts must always be positioned correctly on the wearer's body ⇒ *page 149*.

- ▶ Adjust the front seat and head restraint correctly ⇒ *page 58, General recommendations*.
- ▶ Hold the belt by the tongue and pull it evenly across the chest and pelvis ⇒ *fig. 163*, ⇒ .
- ▶ Insert the tongue into the correct buckle of your seat until you hear it latch securely ⇒ *page 148, fig. 161*.
- ▶ Pull on the belt to make sure that it is securely latched in the buckle.

WARNING

Improperly positioned safety belts can cause serious personal injury in an accident.

- Expectant mothers must always wear the lap portion of the safety belt as low as possible across the pelvis and below the rounding of the abdomen.
- Always read and heed all WARNINGS and other important information ⇒  in *Fastening safety belts on page 149*.

Unfastening safety belts

Unbuckle the safety belt with the red release button only after the vehicle has stopped.



Fig. 164 Releasing the tongue from the buckle

- ▶ Push the red release button on the buckle ⇒ *fig. 164*. The belt tongue will spring out of the buckle ⇒ .
- ▶ Let the belt wind up on the retractor as you guide the belt tongue to its stowed position.

WARNING

Never unfasten safety belt while the vehicle is moving. Doing so will increase your risk of being injured or killed.

Adjusting safety belt height

You can adjust the height of the driver's and front passenger's safety belts.

The safety belt height adjusters for the front seats can be used to adjust the height of the shoulder portion of the safety belt so that it is positioned correctly. ▶

The shoulder belt should lie as close to the center of the collar bone as possible and should fit well on the body ⇒  in *Safety belt position on page 149*.

Power safety belt height adjustment*

You can adjust the height of the safety belts using the multifunction button on the driver or front passenger seat ⇒ *page 60*.

WARNING

Always read and heed all WARNINGS and other important information ⇒ *page 148*.

Tips

You can also adjust the height of the front seats to change the position of the safety belts.

Improperly worn safety belts

Incorrectly positioned safety belts can cause severe injuries.

Wearing safety belts improperly can cause serious injury or death. Safety belts can only work when they are correctly positioned on the body. Improper seating positions reduce the effectiveness of safety belts and will even increase the risk of injury and death by moving the safety belt to critical areas of the body. Improper seating positions also increase the risk of serious injury and death when an airbag deploys and strikes an occupant who is not in the correct seating position. A driver is responsible for the safety of all vehicle occupants and especially for children. Therefore:

- ▶ Never permit anyone to assume an incorrect sitting position in the vehicle while traveling ⇒ .

WARNING

Improperly worn safety belts increase the risk of serious personal injury and death whenever a vehicle is being used.

- Always make sure that all vehicle occupants are correctly restrained and stay in a correct seating position whenever the vehicle is being used.
- Always read and heed all WARNINGS and other important information ⇒ *page 148*.

Safety belt pretensioners

How safety belt pretensioners work

In front, side and rear-end collisions above a particular severity and in a rollover, safety belts are tensioned automatically.

Reversible safety belt tensioners

The safety belts on the front seats are equipped with power reversible tensioners. The following functions are available when the driver's/front passenger's safety belts are fastened:

- Automatic tensioners: at the start of a drive, the safety belts automatically adjust to the passenger after a certain time period or vehicle speed. To switch the automatic tensioners off, select the following in the MMI: **CAR** function button > **Car systems** > **Vehicle settings** > **Seats** > **Driver's seat** or **Passenger's seat** > **Automatic belt tensioner** > **Off**.
- In certain driving situations, the safety belts may tighten with a reversible tensioning function ⇒ *page 197*.
- The safety belts may also tighten with this reversible tensioning function in minor collisions.

Pyrotechnic safety belt pretensioners

The safety belts are equipped with safety belt pretensioners. The system is activated by sensors in front, side and rear-end collisions of great severity and in a rollover. This tightens the belt and takes up belt slack ⇒  in *Service and disposal of safety belt pretensioner on page 152*. Taking up the slack helps to reduce ▶

forward occupant movement during a collision.

WARNING

- It is possible for the pretensioners to deploy incorrectly.
- The pyrotechnic system can only provide protection for one collision. If the pyrotechnic pretensioners deploy, the pretensioning system must be replaced.

Tips

The pyrotechnic safety belt pretensioners can only deploy once.

- The safety belt pretensioners do not deploy in minor frontal and side collisions, in rear-end collisions, in rollovers and in collisions involving very little impact force.
- A fine dust is released when the pyrotechnic safety belt pretensioners deploy. This is normal and is not caused by a fire in the vehicle.
- The relevant safety requirements must be observed when the vehicle or components of the system are scrapped. A qualified dealership is familiar with these regulations and will be pleased to pass on the information to you.
- Be sure to observe all safety, environmental and other regulations if the vehicle or individual parts of the system, particularly the safety belt or airbag, are to be disposed. We recommend you have your authorized Audi dealer perform this service for you.

Service and disposal of safety belt pretensioner

The safety belt pretensioners are parts of the safety belts on your Audi. Installing, removing, servicing or repairing of belt pretensioners can damage the safety belt system and prevent it from working correctly in a collision.

There are some important things you have to know to make sure that the effectiveness of

the system will not be impaired and that discarded components do not cause injury or pollute the environment.

WARNING

Improper care, servicing and repair procedures can increase the risk of personal injury and death by preventing a safety belt pretensioner from activating when needed or activating it unexpectedly:

- The belt pretensioner system can be activated only once. If belt pretensioners have been activated, the system must be replaced.
- Never repair, adjust, or change any parts of the safety belt system.
- Safety belt systems including safety belt pretensioners cannot be repaired. Special procedures are required for removal, installation and disposal of this system.
- For any work on the safety belt system, we strongly recommend that you see your authorized Audi dealer or qualified technician who has an Audi approved repair manual, training and special equipment necessary.

For the sake of the environment

Undeployed airbag modules and pretensioners might be classified as Perchlorate Material -special handling may apply, see www.dtsc.ca.gov/hazardouswaste/perchlorate. When the vehicle or parts of the restraint system including airbag modules safety belts with pretensioners are scrapped, all applicable laws and regulations must be observed. Your authorized Audi dealer is familiar with these requirements and we recommend that you have your dealer perform this service for you.

Airbag system

Important things to know

Importance of wearing safety belts and sitting properly

Airbags are only supplemental restraints. For airbags to do their job, occupants must always properly wear their safety belts and be in a proper seating position.

For your safety and the safety of your passengers, before driving off, always:

- ▶ Adjust the driver's seat and steering wheel properly ⇒ *page 136*,
- ▶ Adjust the front passenger's seat properly ⇒ *page 59*,
- ▶ Wear safety belts properly ⇒ *page 148*,
- ▶ Always properly use the proper child restraint to protect children ⇒ *page 177*.

In a collision, airbags must inflate within the blink of an eye and with considerable force. The supplemental airbags can cause injuries if the driver or the front seat passenger is not seated properly. Therefore in order to help the airbag to do its job, it is important, both as a driver and as a passenger to sit properly at all times.

By keeping room between your body and the steering wheel and the front of the passenger compartment, the airbag can inflate fully and completely and provide supplemental protection in certain frontal collisions ⇒ *page 136*, *Proper occupant seating positions*. For details on the operation of the seat adjustment controls ⇒ *page 59*.

It's especially important that children are properly restrained ⇒ *page 177*.

There is a lot that the driver and the passengers can and must do to help the individual safety features installed in your Audi work together as a system.

Proper seating position is important so that the front airbag on the driver side can do its job. If you have a physical impairment or con-

dition that prevents you from sitting properly on the driver seat with the safety belt properly fastened and reaching the pedals, or if you have concerns with regard to the function or operation of the Advanced Airbag System, please contact your authorized Audi dealer or qualified workshop, or call Audi Customer Relations at 1-800-822-2834 for possible modifications to your vehicle.

When the airbag system deploys, a gas generator will fill the airbags, break open the padded covers, and inflate between the steering wheel and the driver and between the instrument panel and the front passenger. The airbags will deflate immediately after deployment so that the front occupants can see through the windshield again without interruption.

All of this takes place in the blink of an eye, so fast that many people don't even realize that the airbags have deployed. The airbags also inflate with a great deal of force and nothing should be in their way when they deploy. Front airbags in combination with properly worn safety belts slow down and limit the occupant's forward movement. Together they help to prevent the driver and front seat passenger from hitting parts of the inside of the vehicle while reducing the forces acting on the occupant during the crash. In this way they help to reduce the risk of injury to the head and upper body in the crash. Airbags do not protect the arms or the lower parts of the body.

Both front airbags will not inflate in all frontal collisions. The triggering of the airbag system depends on the vehicle deceleration rate caused by the collision and registered by the electronic control unit. If this rate is below the reference value programmed into the control unit, the airbags will not be triggered, even though the car may be badly damaged as a result of the collision. Vehicle damage, repair costs or even the lack of vehicle damage is not necessarily an indication of whether an airbag should inflate or not. ▶

Since the circumstances will vary considerably between one collision and another, it is not possible to define a range of vehicle speeds that will cover every possible kind and angle of impact that will always trigger the airbags. Important factors include, for example, the nature (hard or soft) of the object which the car hits, the angle of impact, vehicle speed, etc. The front airbags will also not inflate in side or rear collisions, or in roll-overs.

Always remember: Airbags will deploy only once, and only in certain kinds of collisions. Your safety belts are always there to offer protection in those situations in which airbags are not supposed to deploy, or when they have already deployed; for example, when your vehicle strikes or is struck by another vehicle after the first collision.

This is just one of the reasons why an airbag is a supplementary restraint and is not a substitute for a safety belt. The airbag system works most effectively when used with the safety belts. Therefore, always properly wear your safety belts ⇒ *page 145*.

WARNING

- Sitting too close to the steering wheel or instrument panel will decrease the effectiveness of the airbags and will increase the risk of personal injury in a collision.
- Never sit closer than 10 inches (25 cm) to the steering wheel or instrument panel.
 - If you cannot sit more than 10 inches (25 cm) from the steering wheel, investigate whether adaptive equipment may be available to help you reach the pedals and increase your seating distance from the steering wheel.
 - If you are unrestrained, leaning forward, sitting sideways or out of position in any way, your risk of injury is much higher.
 - You will also receive serious injuries and could even be killed if you are up against the airbag or too close to it when it inflates - even with an Advanced Airbag.

- To reduce the risk of injury when an airbag inflates, always wear safety belts properly ⇒ *page 148, Safety belts*.
- Always make certain that children age 12 or younger always ride in the rear seat. If children are not properly restrained, they may be severely injured or killed when an airbag inflates.
- Never let children ride unrestrained or improperly restrained in the vehicle. Adjust the front seats properly.
- Never ride with the backrest reclined.
- Always sit as far as possible from the steering wheel or the instrument panel ⇒ *page 136*.
- Always sit upright with your back against the backrest of your seat.
- Never place your feet on the instrument panel or on the seat. Always keep both feet on the floor in front of the seat to help prevent serious injuries to the legs and hips if the airbag inflates.
- Never recline the front passenger's seat to transport objects. Items can also move into the area of the side airbag or the front airbag during braking or in a sudden maneuver. Objects near the airbags can become projectiles and cause injury when an airbag inflates.

WARNING

- Airbags that have deployed in a crash must be replaced.
- Use only original equipment airbags approved by Audi and installed by a trained technician who has the necessary tools and diagnostic equipment to properly replace any airbag in your vehicle and assure system effectiveness in a crash.
 - Never permit salvaged or recycled airbags to be installed in your vehicle.

Child restraints on the front seat – some important things to know

- ▶ Be sure to read the important information and heed the WARNINGS for important details about children and Advanced Airbags ⇒ *page 177*.

Even though your vehicle is equipped with an Advanced Airbag System, make certain that all children, especially those 12 years and younger, always ride in the back seat properly restrained for their age and size. The airbag on the passenger side makes the front seat a potentially dangerous place for a child to ride. The front seat is not the safest place for a child in a forward-facing child seat. It can be a very dangerous place for an infant or a child in a rearward-facing seat.

The Advanced Airbag System in your vehicle has been certified to comply with the requirements of United States Federal Motor Vehicle Safety Standard 208 as applicable at the time your vehicle was manufactured.

The Standard requires the front airbag on the passenger side to be turned off (“suppressed”) if a child up to about one year of age restrained in one of the rear-facing or forward-facing infant restraints listed in Federal Motor Vehicle Safety Standard 208 with which the Advanced Airbag System in your vehicle was certified has been installed on the front passenger seat. For a listing of the child restraints that were used to certify compliance with the US Safety Standard ⇒ *page 179*.

The **PASSENGER AIR BAG OFF** light in the instrument panel tells you when the front Advanced Airbag on the passenger side has been turned off by the electronic control unit.

Each time you switch on the ignition, the **PASSENGER AIR BAG OFF** light will come on for a few seconds and:

- will stay on if the front passenger seat is not occupied,
- will stay on if there is a small child or child restraint on the front passenger seat,

- will go off if the front passenger seat is occupied by an adult as registered by the weight-sensing mat ⇒ *page 164, Monitoring the Advanced Airbag System*.

The **PASSENGER AIR BAG OFF** light comes on when the control unit detects a total weight on the front passenger seat that requires the front airbag to be turned off.

If the total weight on the front passenger seat is more than that of a typical 1 year-old child but less than the weight of a small adult, the front airbag on the passenger side can deploy (the **PASSENGER AIR BAG OFF** light does not come on). If the **PASSENGER AIR BAG OFF** light does not come on, the front airbag on the passenger side has not been turned off by the electronic control unit and can deploy if the control unit senses an impact that meets the conditions stored in its memory.

For example, the airbag may deploy if:

- a small child that is heavier than a typical 1 year-old child is on the front passenger seat (regardless of whether the child is in one of the child seats listed ⇒ *page 179*), or
- a child who has outgrown child restraints is on the front passenger seat.

If the front passenger airbag is turned off, the **PASSENGER AIR BAG OFF** light comes on in the instrument cluster and stays on.

The front airbag on the passenger side may *not* deploy (the **PASSENGER AIR BAG OFF** light does not illuminate and stay lit) even if a small adult or teenager, or a passenger who is not sitting upright with their back against a non-reclined backrest with their feet on the vehicle floor in front of the seat is on the front passenger seat ⇒ *page 136, Proper seating position for the driver*.

If the front passenger airbag deploys, the Federal Standard requires the airbag to meet the “low risk” deployment criteria to reduce the risk of injury through interaction with the airbag. “Low risk” deployment occurs in those crashes that take place at lower decelerations ▶

as defined in the electronic control unit
 ⇒ *page 164, PASSENGER AIR BAG OFF light.*

Always remember, a child seat or infant carrier installed on the front seat may be struck and knocked out of position by the rapidly inflating passenger's airbag in a frontal collision. The airbag could greatly reduce the effectiveness of the child restraint and even seriously injure the child during inflation.

For this reason, and because the back seat is the safest place for children - when properly restrained according to their age and size - we strongly recommend that children always sit in the back seat ⇒ *page 177, Child Safety.*

WARNING

A child in a rearward-facing child seat installed on the front passenger seat will be seriously injured and can be killed if the front airbag inflates - even with an Advanced Airbag System.

- The inflating airbag will hit the child seat or infant carrier with great force and will smash the child seat and child against the backrest, center armrest, door or roof.
- Always install rear-facing child seats on the rear seat.
- If you must install a rearward facing child seat on the front passenger seat because of exceptional circumstances and the **PASSENGER AIR BAG OFF** light does not come on and stay on, immediately install the rear-facing child seat in a rear seating position and have the airbag system inspected by your Audi dealer.
- Forward-facing child seats installed on the front passenger's seat may interfere with the deployment of the airbag and cause serious personal injury to the child.

WARNING

If, in exceptional circumstances, you must install a forward-facing child restraint on the front passenger's seat:

- Always make sure the forward-facing seat has been designed and certified by its manufacturer for use on a front seat with a passenger front and side airbag.
- Never put the forward-facing child restraint up against or very near the instrument panel.
- Always move the passenger seat into its rearmost position in the seat's fore and aft adjustment range, as far away from the airbag as possible before installing the forward-facing child restraint. The backrest must be adjusted to an upright position.
- Make sure that the **PASSENGER AIR BAG OFF** light comes on and stays on all the time whenever the ignition is switched on.

WARNING

To reduce the risk of serious injury, make sure that the **PASSENGER AIR BAG OFF** light will be displayed whenever a child restraint is installed on the front passenger seat and the ignition is switched on.

- If the **PASSENGER AIR BAG OFF** light does not stay on, perform the checks described ⇒ *page 164, Monitoring the Advanced Airbag System.*
- Take the child restraint off the front passenger seat and install it properly at one of the rear seat positions if the **PASSENGER AIR BAG OFF** light does not stay on.
- Have the airbag system inspected by your Audi dealer immediately.
- Always carefully follow instructions from child restraint manufacturers when installing child restraints.

WARNING

If, in exceptional circumstances, you must install a forward or rearward-facing child restraint on the front passenger's seat:

- Improper installation of child restraints can reduce their effectiveness or even prevent them from providing any protection.

- An improperly installed child restraint can interfere with the airbag as it deploys and seriously injure or even kill the child – even with an Advanced Airbag System.
- Always carefully follow the manufacturer's instructions provided with the child seat or carrier.
- Never place additional items on the seat that can increase the total weight registered by the weight-sensing mat and can cause injury in a crash.

Front airbags

Description of front airbags

The airbag system can provide supplemental protection to properly restrained front seat occupants.



Fig. 165 Location of driver airbag: in steering wheel



Fig. 166 Location of front passenger's airbag: in the instrument panel

Your vehicle is equipped with an “Advanced Airbag System” in compliance with United States Federal Motor Vehicle Safety Standard (FMVSS) 208 as applicable at the time your vehicle was manufactured. The system senses the position of the front seats and controls front airbag inflation with a valve, depending

on the distance between the respective seat and the steering wheel or instrument panel. The safety belts for the seats have “pretensioners” that help to take slack out of the belt system. The pretensioners are also activated by the electronic control unit for the airbag system.

The front safety belts also have load limiters to help reduce the forces applied to the body in a crash.

The airbag for the driver is in the steering wheel hub ⇒ *fig. 165* and the airbag for the front passenger is in the instrument panel ⇒ *fig. 166*. The general location of the airbags is marked “AIRBAG”.

There is a lot you need to know about the airbags in your vehicle. We urge you to read the detailed information about airbags, safety belts and child safety in this and the other chapters that make up the owner's literature. Please be sure to heed the WARNINGS - they are extremely important for your safety and the safety of your passengers, especially infants and small children.

WARNING

- Never rely on airbags alone for protection.
- Even when they deploy, airbags provide only supplemental protection.
- Airbag work most effectively when used with properly worn safety belts.
- Therefore, always wear your safety belts and make sure that everybody in your vehicle is properly restrained.

WARNING

- A person on the front passenger seat, especially infants and small children, will receive serious injuries and can even be killed by being too close to the airbag when it inflates.
- Although the Advanced Airbag System in your vehicle is designed to turn off the front passenger airbag if an infant or a small child is on the front passenger seat, nobody can absolutely guarantee

that deployment under these special conditions is impossible in all conceivable situations that may happen during the useful life of your vehicle.

- The Advanced Airbag System can deploy in accordance with the “low risk” option under the U.S. Federal Standard if a child that is heavier than the typical one-year old child is on the front passenger seat and the other conditions for airbag deployment are met.
- Accident statistics have shown that children are generally safer in the rear seat area than in the front seating position.
- For their own safety, all children, especially 12 years and younger, should always ride in the back properly restrained for their age and size.

Advanced front airbag system

Your vehicle is equipped with a front Advanced Airbag System in compliance with United States Federal Motor Vehicle Safety Standard 208 as applicable at the time your vehicle was manufactured.

The front Advanced Airbag System supplements the safety belts to provide additional protection for the driver's and front passenger's heads and upper bodies in frontal crashes. The airbags inflate only in frontal impacts when the vehicle deceleration is high enough.

The front Advanced Airbag System for the front seat occupants is not a substitute for your safety belts. Rather, it is part of the overall occupant restraint system in your vehicle. Always remember that the airbag system can only help to protect you, if you are sitting upright, wearing your safety belt and wearing it properly. This is why you and your passengers must always be properly restrained, not just because the law requires you to be.

The Advanced Airbag System in your vehicle has been certified to meet the “low risk” requirements for 3 and 6 year-old children on the passenger side and very small adults on the driver side. The low risk deployment crite-

ria are intended to help reduce the risk of injury through interaction with the front airbag that can occur, for example, by being too close to the steering wheel and instrument panel when the airbag inflates.

In addition, the system has been certified to comply with the “suppression” requirements of the Safety Standard, to turn off the front airbag for infants 12 months old and younger who are restrained on the front passenger seat in child restraints that are listed in the Standard ⇒ *page 179, Child restraints and Advanced Airbags*.

“Suppression” requires the front airbag on the passenger side to be turned off if:

- a child up to about one year of age is restrained on the front passenger seat in one of the rear-facing or forward-facing infant restraints listed in Federal Motor Vehicle Safety Standard 208 with which the Advanced Airbag System in your vehicle was certified. For a listing of the child restraints that were used to certify your vehicle's compliance with the US Safety Standard ⇒ *page 179*,
- weight less than a threshold level stored in the control unit is detected on the front passenger seat.

When a person is detected on the front passenger seat, weighing more than the total weight of a child that is about 1 year old restrained in one of the rear-facing or forward-facing infant restraints (listed in Federal Motor Vehicle Safety Standard 208 with which the Advanced Airbag System in your vehicle was certified), the front airbag on the passenger side may or may not deploy.

The **PASSENGER AIR BAG OFF** light comes on when the electronic control unit detects a total weight on the front passenger seat that requires the front airbag to be turned off. If the **PASSENGER AIR BAG OFF** light does not come on, the front airbag on the passenger side has not been turned off by the control unit and can deploy if the control unit senses ►

an impact that meets the conditions stored in its memory.

If the total weight on the front passenger seat is more than that of a typical 1 year-old, but less than the weight of a small adult, the front airbag on the passenger side may deploy (the **PASSENGER AIR BAG OFF** light does not come on).

For example, the airbag may deploy if:

- a small child that is heavier than a typical 1 year-old child is on the front passenger seat (regardless of whether the child is in one of the child seats listed ⇒ *page 179*),
- a child who has outgrown child restraints is on the front passenger seat.

If the front passenger airbag is turned off, the **PASSENGER AIR BAG OFF** light in the center of the instrument panel will come on and stay on.

The front airbag on the passenger side may *not* deploy (the **PASSENGER AIR BAG OFF** light does not illuminate and stay lit) if:

- a small adult or teenager is on the front passenger seat
- a passenger who is not sitting upright with their back against a non-reclined backrest with their feet on the vehicle floor in front of the seat is on the front passenger seat.

If the front passenger airbag deploys, the Federal Standard requires the airbag to meet the “low risk” deployment criteria to help reduce the risk of injury through interaction with the airbag. “Low risk” deployment occurs in those crashes that take place at lower decelerations as defined in the electronic control unit ⇒ *page 164*.

Always remember: Even though your vehicle is equipped with Advanced Airbags, the safest place for children is properly restrained on the back seat. Please be sure to read the important information in the sections that follow and be sure to heed all of the WARNINGS.

WARNING

To reduce the risk of injury when an airbag inflates, always wear safety belts properly.

- If you are unrestrained, leaning forward, sitting sideways or out of position in any way, your risk of injury is much higher.
- You will also receive serious injuries and could even be killed if you are up against the airbag or too close to it when it inflates - even with an Advanced Airbag ⇒ *page 153*.

WARNING

A child in a rearward-facing child seat installed on the front passenger seat will be seriously injured and can be killed if the front airbag inflates - even with an Advanced Airbag System.

- Although the Advanced Airbag System in your vehicle is designed to turn off the front airbag when a rearward-facing child restraint has been installed on the front passenger seat, nobody can absolutely guarantee that deployment is impossible in all conceivable situations that may happen during the useful life of your vehicle.
- The inflating airbag will hit the child seat or infant carrier with great force and will smash the child seat and child against the backrest, center armrest, door, or roof.
- Always install rearward-facing child restraints on the rear seat.
- If you must install a rearward facing child seat on the front passenger seat because of exceptional circumstances and the **PASSENGER AIR BAG OFF** light does not come on and stay on, immediately install the rear-facing child seat in a rear seating position and have the airbag system inspected by your Audi dealer.

WARNING

If, in exceptional circumstances, you must install a forward-facing child restraint on the front passenger's seat:

- Always make sure the forward-facing seat has been designed and certified by its manufacturer for use on a front seat with a passenger front and side airbag.
- Never put the forward-facing child restraint up against or very near the instrument panel.
- Always move the passenger seat into its rearmost position in the seat's fore and aft adjustment range, as far away from the airbag as possible, before installing the forward-facing child restraint. The backrest must be adjusted to an upright position.
- Make sure that the **PASSENGER AIR BAG OFF** light comes on and stays on all the time whenever the ignition is switched on.

Advanced Airbag System components

The front passenger seat in your vehicle has a lot of very important parts of the Advanced Airbag System in it. These parts include the weight-sensing mat, sensors, wiring, brackets, and more. The function of the system in the front passenger seat is checked by the electronic control unit when the ignition is on. The control unit monitors the Advanced Airbag System and turns the airbag indicator light on when a malfunction in the system components is detected. The function of the airbag indicator light is described in greater detail below. Because the front passenger seat contains important parts of the Advanced Airbag System, you must take care to prevent it from being damaged. Damage to the seat may prevent the Advanced Airbag for the front passenger seat from doing its job in a crash.

The front Advanced Airbag System consists of the following:

- Crash sensors in the front of the vehicle that measure vehicle acceleration/deceleration to provide information to the Advanced Airbag System about the severity of the crash.
- An electronic control unit, with integrated crash sensors for front and side impacts. The control unit “decides” whether to fire the front airbags based on the information received from the crash sensors. The control unit also “decides” whether the safety belt pretensioners should be activated.
- An Advanced Airbag with gas generator and control valve for the driver inside the steering wheel hub.
- An Advanced Airbag with gas generator and control valve inside the instrument panel for the front passenger.
- A weight-sensing mat under the upholstery padding of the front passenger seat cushion that measures the total weight on the seat. The information registered is sent continuously to the electronic control unit to regulate deployment of the front Advanced Airbag on the passenger side.
- An airbag monitoring system and indicator light in the instrument cluster ⇒ *page 164*.
- A sensor in each front seat registers the distance between the respective seat and the steering wheel or instrument panel. The information registered is sent continuously to the electronic control unit to regulate deployment of the front Advanced Airbags.
- The **PASSENGER AIR BAG OFF** light comes on and stays on in the center of the instrument panel ⇒ *page 164, fig. 168* and tells you when the front Advanced Airbag on the passenger side has been turned off.
- A sensor below the safety belt latch for the front seat passenger to measure the tension on the safety belt. The tension on the safety belt and the weight registered by the weight-sensing mat help the control unit “decide” whether the front airbag for the front passenger seat should be turned off or not ⇒ *page 155, Child restraints on the front seat – some important things to know*.
- A sensor in the safety belt latch for the driver and for the front seat passenger that senses whether that safety belt is latched or not and transmits this information to the electronic control unit.

! WARNING

Damage to the front passenger seat can prevent the front airbag from working properly.

- Improper repair or disassembly of the front passenger and driver seat will prevent the Advanced Airbag System from functioning properly.
- Repairs to the front passenger seat must be performed by qualified and properly trained workshop personnel.
- Never remove the front passenger or driver seat from the vehicle.
- Never remove the upholstery from the front passenger seat.
- Never disassemble or remove parts from the seat or disconnect wires from it.
- Never carry sharp objects in your pockets or place them on the seat. If the weight-sensing mat in the passenger seat is punctured it cannot work properly.
- Never carry things on your lap or carry objects on the passenger seat. Such items can increase the weight registered by the weight-sensing mat and send the wrong information to the airbag control unit.
- Never store items under the front passenger seat. Parts of the Advanced Airbag System under the passenger seat could be damaged, preventing them and the airbag system from working properly.
- Never place seat covers or replacement upholstery that have not been specifically approved by Audi on the front seats.
- Seat covers can prevent the Advanced Airbag System from recognizing child restraints or occupants on the front passenger seat and prevent the side airbag in the seat backrest from deploying properly.
- Never use cushions, pillows, blankets or similar items on the front passenger seat. The additional padding will prevent the weight-sensing mat in the seat from accurately registering the child restraint

or person on the seat and prevent the Advanced Airbag System from functioning properly.

- If you must use a child restraint on the front passenger seat and the child restraint manufacturer's instructions require the use of a towel, foam cushion or something else to properly position the child restraint, make certain that the **PASSENGER AIR BAG OFF** light comes on and stays on whenever the child restraint is installed on the front passenger seat.
- If the **PASSENGER AIR BAG OFF** light does not come on and stay on, immediately install child restraint in a rear seating position and have the airbag system inspected by your Audi dealer.

How the Advanced Airbag System components work together

The front Advanced Airbag System and the side airbags supplement the protection offered by the front three-point safety belts with pretensioners and load limiters and the adjustable head restraints to help reduce the risk of injury in a wide range of accident and crash situations. Be sure to read the important information about safety and heed the WARNINGS in this chapter.

Deployment of the Advanced Airbag System and the activation of the safety belt pretensioners depend on the deceleration measured by the crash sensors and registered by the electronic control unit. The amount of inflation of the front airbags can also be adapted to the front seat position, depending on the distance between the respective front seat and the steering wheel or instrument panel as registered by sensors in the seats. Crash severity depends on speed and deceleration as well as the mass and stiffness of the vehicle or object involved in the crash.

On the passenger side, regardless of safety belt use, the airbag will be turned off if the weight on the passenger seat is less than the ▶

amount programmed in the electronic control unit. The front airbag on the passenger side will also be turned off if one of the child seats that has been certified under Federal Motor Vehicle Safety Standard 208 has been recognized on the seat. The **PASSENGER AIR BAG OFF** light comes on and stays on to tell you when the front Advanced Airbag on the passenger side has been turned off ⇒ *page 155, Child restraints on the front seat – some important things to know.*

WARNING

To reduce the risk of injury when an airbag inflates, always wear safety belts properly.

- If you are unrestrained, leaning forward, sitting sideways or out of position in any way, your risk of injury is much higher.
- You will also receive serious injuries and could even be killed if you are up against the airbag or too close to it when it inflates - even with an Advanced Airbag ⇒ *page 153.*

More important things to know about front airbags



Fig. 167 Inflated front airbags

Safety belts are important to help keep front seat occupants in the proper seated position so that airbags can unfold properly and provide supplemental protection in a frontal collision.

The front airbags are designed to provide additional protection for the chest and face of the driver and the front seat passenger when:

- safety belts are worn properly,

- the seats have been positioned so that the occupant is properly seated as far as possible from the airbag,
- and the head restraints have been properly adjusted.

Because airbags inflate in the blink of an eye with great force, things you have on your lap or have placed on the seat could become dangerous projectiles, and be pushed into you if the airbag inflates.

When an airbag deploys, fine dust is released. This is normal and is not caused by a fire in the vehicle. This dust is made up mostly of a powder used to lubricate the airbags as they deploy. It could irritate skin.

It is important to remember that while the supplemental airbag system is designed to reduce the likelihood of serious injuries, other injuries, for example swelling, bruising and minor abrasions, can also happen when airbags inflate. Airbags do not protect the arms or the lower parts of the body. Front airbags supplement the three-point safety belts only in some frontal collisions in which the vehicle deceleration is high enough to deploy the airbags.

Front airbags will not deploy:

- if the ignition is switched off when a crash occurs,
- in side collisions,
- in rear-end collisions,
- in rollovers,
- when the crash deceleration measured by the airbag system is less than the minimum threshold needed for airbag deployment as registered by the electronic control unit.

The front passenger airbag also will not deploy:

- when the front passenger seat is not occupied,
- when the weight on the front passenger seat as sensed by the Advanced Airbag System indicates that the front airbag on the passenger side has to be turned off by the

electronic control unit (the **PASSENGER AIR BAG OFF** light comes on and stays on).

WARNING

Sitting in the wrong position can increase the risk of serious injury in crashes.

- To reduce the risk of injury when the airbags inflate, the driver and passengers must always sit in an upright position, must not lean against or place any part of their body too close to the area where the airbags are located.
- Occupants who are unbelted, out of position or too close to the airbag can be seriously injured by an airbag as it unfolds with great force in the blink of an eye
⇒ page 155.

WARNING

A child in a rearward-facing child seat installed on the front passenger seat will be seriously injured and can be killed if the front airbag inflates - even with an Advanced Airbag System.

- The inflating airbag will hit the child seat or infant carrier with great force and will smash the child seat and child against the backrest, center armrest, door or roof.
- Always install rear-facing child seats on the rear seat.
- If you must install a rearward facing child seat on the front passenger seat because of exceptional circumstances and the **PASSENGER AIR BAG OFF** light does not come on and stay on, immediately install the rear-facing child seat in a rear seating position and have the airbag system inspected by your Audi dealer.

WARNING

Objects between you and the airbag will increase the risk of injury in a crash by interfering with the way the airbag unfolds or by being pushed into you as the airbag inflates.

- Never hold things in your hands or on your lap when the vehicle is in use.
- Never transport items on or in the area of the front passenger seat. Objects could move into the area of the front airbags during braking or other sudden maneuvers and become dangerous projectiles that can cause serious personal injury if the airbags inflate.
- Never place or attach accessories or other objects (such as cup holders, telephone brackets, large, heavy or bulky objects) on the doors, over or near the area marked "AIRBAG" on the steering wheel, instrument panel, seat backrests or between those areas and yourself. These objects could cause injury in a crash, especially when the airbags inflate.
- Never recline the front passenger's seat to transport objects. Items can also move into the area of the side airbag or the front airbag during braking or in a sudden maneuver. Objects near the airbags can become projectiles and cause injury, particularly when the seat is reclined.

WARNING



The fine dust created when airbags deploy can cause breathing problems for people with a history of asthma or other breathing conditions.

- To reduce the risk of breathing problems, those with asthma or other respiratory conditions should get fresh air right away by getting out of the vehicle or opening windows or doors.
- If you are in a collision in which airbags deploy, wash your hands and face with mild soap and water before eating.
- Be careful not to get the dust into your eyes, or into any cuts or scratches.
- If the residue should get into your eyes, flush them with water.

Monitoring the Advanced Airbag System

(USA models) / (Canada models) Airbag monitoring indicator light

Two separate indicators monitor the function of the Advanced Airbag System: the airbag monitoring indicator light and the **PASSENGER AIR BAG OFF** light.

The Advanced Airbag System (including the electronic control unit, sensor circuits and system wiring) is monitored continuously to make sure that it is functioning properly whenever the ignition is on. Each time you switch on the ignition, the airbag monitoring indicator light  (USA models) /  (Canada models) will come on for a few seconds (self diagnostics).

The system must be inspected when the indicator light  (USA models) /  (Canada models):

- does not come on when the ignition is switched on,
- does not go out a few seconds after you have switched on the ignition, or
- comes on while driving.

If an airbag system malfunction is detected, the indicator light will first start flashing to catch the driver's attention and then stay on continuously to serve as a constant reminder to have the system inspected immediately.

If a malfunction occurs that turns the front airbag on the passenger side off, the **PASSENGER AIR BAG OFF** light will come on and stay on whenever the ignition is on.

WARNING

An airbag system that is not functioning properly cannot provide supplemental protection in a frontal crash.

- If the airbag indicator light ⇒ *page 18* comes when the vehicle is being used, have the system inspected immediately by your authorized Audi dealer. It is pos-

sible that the airbag will inflate when it is not supposed to, or will not inflate when it should.

PASSENGER AIR BAG OFF light



Fig. 168 Section from the instrument panel: **PASSENGER AIR BAG OFF** light

The **PASSENGER AIR BAG OFF** light is located in the center of the instrument panel ⇒ *fig. 168*.

The **PASSENGER AIR BAG OFF** light will come on and stay on to tell you when the front Advanced Airbag on the passenger side has been turned off by the electronic control unit. Each time you switch on the ignition, the **PASSENGER AIR BAG OFF** light will flash for a few seconds and:

- will stay on if the front passenger seat is not occupied,
- will stay on if there is a small child or child restraint on the front passenger seat,
- will go out if the front passenger seat is occupied by an adult as registered by the weight-sensing mat.

The **PASSENGER AIR BAG OFF** light **must come on and stay on** if the ignition is on and

- a car bed has been installed on the front seat, or
- a rearward-facing child restraint has been installed on the front passenger seat, or
- a forward-facing child restraint has been installed on the front passenger seat, or

- the weight registered on the front passenger seat is equal to or less than the combined weight of a typical 1 year-old restrained in one of the rear-facing or forward-facing infant restraints listed in Federal Motor Vehicle Safety Standard 208 with which the Advanced Airbag System in your vehicle was certified.

If the front passenger seat is not occupied, the front airbag will not deploy, and the **PASSENGER AIR BAG OFF** light will stay on. Never install a rearward-facing child restraint on the front passenger seat, the safest place for a child in any kind of child restraint is at one of the seating positions on the rear seat
 ⇒ *page 155, Child restraints on the front seat – some important things to know* and
 ⇒ *page 177, Child Safety.*

If the PASSENGER AIR BAG OFF light comes on when one of the conditions listed above is met, be sure to check the light regularly to make certain that the **PASSENGER AIR BAG OFF** light stays on continuously whenever the ignition is on. If the **PASSENGER AIR BAG OFF** light does not appear on and does not stay on all the time, stop as soon as it is safe to do so and

- reactivate the system by switching the ignition off and then switching it on again;
- remove and reinstall the child restraint. Make sure that the child restraint is properly installed and that the safety belt for the front passenger seat has been correctly routed through the child restraint as described in the child restraint manufacturer's instructions;
- make sure that the convertible locking feature on the safety belt for the front passenger seat has been activated and that the safety belt has been pulled tight. The belt must not be loose or have loops of slack so that the sensor below the safety belt latch on the seat can do its job ⇒ *page 187.*
- make sure that things that may increase the weight of the child and child seat are not being transported on the front passenger seat;

- make sure that the safety belt tension sensor is not blocked. Shake the safety belt latch on the front passenger seatback and forth;
- If a strap or tether is being used to tie the child seat to the front passenger seat, make sure that it is not so tight that it causes the weight-sensing mat to measure more weight than is actually on the seat.

If the PASSENGER AIR BAG OFF light still does not come on and does not stay on continuously (when the ignition is switched on),

- take the child restraint off the front passenger seat and install it properly at one of the rear seat positions. Have the airbag system inspected by your Audi dealer immediately.
- move the child to a rear seat position and make sure that the child is properly restrained in a child restraint that is appropriate for its size and age.

The **PASSENGER AIR BAG OFF** light should NOT come on when the ignition is on and an adult is sitting in a proper seating position on the front passenger seat. If the **PASSENGER AIR BAG OFF** light comes on and stays on or flashes for about 5 seconds while driving, under these circumstances, make sure that:

- the adult on the front passenger seat is properly seated on the center of the seat cushion with his or her back up against the backrest and the backrest is not reclined
 ⇒ *page 136, Proper occupant seating positions,*
- the adult is not taking weight off the seat by holding on to the passenger assist handle above the front passenger door or supporting their weight on the armrest,
- the safety belt is being properly worn and that there is not a lot of slack in the safety belt webbing,
- accessory seat covers or cushions or other things that may cause an incorrect reading or impression on the weight-sensing mat under the upholstery of the seat have been removed from the front passenger seat, ▶

- a safety belt extender has not been left in the safety belt latch for the front passenger seat.

In addition to the **PASSENGER AIR BAG OFF** light in the center of the instrument panel, the message **PASSENGER AIR BAG OFF** or **PASSENGER AIR BAG ON** will briefly appear in the instrument cluster display. This is to inform the driver of the current front passenger airbag status.

Important safety instructions on monitoring the Advanced Airbag System

WARNING

An airbag system that is not functioning properly cannot provide supplemental protection in a frontal crash.

- If the airbag indicator light ⇨ *page 18* comes when the vehicle is being used, have the system inspected immediately by your authorized Audi dealer. It is possible that the airbag will inflate when it is not supposed to, or will not inflate when it should.

WARNING

If the front airbag inflates, a child without a child restraint, or in a rearward-facing child safety seat, or in a forward-facing child restraint that has not been properly installed will be seriously injured and can be killed.

- Even though your vehicle is equipped with an Advanced Airbag System, make certain that all children, especially 12 years and younger, always ride on the back seat properly restrained for their age and size.
- Always install forward or rear-facing child seats on the rear seat – even with an Advanced Airbag System.
- If you must install a rearward-facing child seat on the front passenger seat because of exceptional circumstances and the **PASSENGER AIR BAG OFF** light does not appear and stay on, immediate-

ly install the rear-facing child seat in a rear seating position and have the airbag system inspected by your Audi dealer.

- A tight tether or other strap on a rearward-facing child restraint attached to the front passenger seat can put too much pressure on the weight-sensing mat in the seat and register more weight than is actually on the seat. The heavier weight registered can make the system work as though an adult were on the seat and deploy the Advanced Airbag when it must be suppressed causing serious or even fatal injury to the child.
- If, in exceptional circumstances, you must install a forward-facing child restraint on the front passenger seat, always move the seat into its rearmost position in the seat's fore and aft adjustment range, as far away from the airbag as possible. The backrest must be adjusted to an upright position. Make sure that the **PASSENGER AIR BAG OFF** light comes on and stays on all the time whenever the ignition is switched on.

WARNING

- If the **PASSENGER AIR BAG OFF** light does not go out when an adult is sitting on the front passenger seat after taking the steps described above, make sure the adult is properly seated and restrained at one of the rear seating positions.
- Have the airbag system inspected by your Audi dealer before transporting anyone on the front passenger seat.

Tips

If the weight-sensing mat in the front passenger seat detects an empty seat, the front airbag on the passenger side will be turned off, and the **PASSENGER AIR BAG OFF** light will stay on.

Repair, care and disposal of the airbags

Parts of the airbag system are installed at many different places on your Audi. Installing, ►

removing, servicing or repairing a part in an area of the vehicle can damage a part of an airbag system and prevent that system from working properly in a collision.

There are some important things you have to know to make sure that the effectiveness of the system will not be impaired and that discarded components do not cause injury or pollute the environment.

WARNING

Improper care, servicing and repair procedures can increase the risk of personal injury and death by preventing an airbag from deploying when needed or deploying an airbag unexpectedly:

- Never cover, obstruct, or change the steering wheel horn pad or airbag cover or the instrument panel or modify them in any way.
- Never attach any objects such as cup holders or telephone mountings to the surfaces covering the airbag units.
- For cleaning the horn pad or instrument panel, use only a soft, dry cloth or one moistened with plain water. Solvents or cleaners could damage the airbag cover or change the stiffness or strength of the material so that the airbag cannot deploy and protect properly.
- Never repair, adjust, or change any parts of the airbag system.
- All work on the steering wheel, instrument panel, front seats or electrical system (including the installation of audio equipment, cellular telephones and CB radios, etc.) must be performed by a qualified technician who has the training and special equipment necessary.
- For any work on the airbag system, we strongly recommend that you see your authorized Audi dealer or qualified workshop.
- Never modify the front bumper or parts of the vehicle body.
- Always make sure that the side airbag can inflate without interference:

- Never install seat covers or replacement upholstery over the front seat-backs that have not been specifically approved by Audi.
- Never use additional seat cushions that cover the areas where the side airbags inflate.
- Damage to the original seat covers or to the seam in the area of the side airbag module must always be repaired immediately by an authorized Audi dealer.
- The airbag system can be activated only once. After an airbag has inflated, it must be replaced by an authorized Audi dealer or qualified technician who has the technical information, training and special equipment necessary.
- The airbag system can be deployed only once. After an airbag has been deployed, it must be replaced with new replacement parts designed and approved especially for your Audi model version. Replacement of complete airbag systems or airbag components must be performed by qualified workshops only. Make sure that any airbag service action is entered in your Audi Warranty & Maintenance booklet under *AIRBAG REPLACEMENT RECORD*.
- For safety reasons in severe accidents, the alternator and starter are separated from the vehicle battery with a pyrotechnic circuit interrupter.
 - Work on the pyrotechnic circuit interrupter must only be performed by a qualified dealer - risk of an accident!
 - If the vehicle or the circuit interrupter is scrapped, all applicable safety precautions must be followed.



For the sake of the environment

Undeployed airbag modules and pretensioners might be classified as Perchlorate Material - special handling may apply, see www.dtsc.ca.gov/hazardouswaste/perchlorate. When the vehicle or parts of the restraint system including airbag modules

and safety belts with pretensioners are scrapped, all applicable laws and regulations must be observed. Your authorized Audi dealer is familiar with these requirements and we recommend that you have your dealer perform this service for you.

Other things that can affect Advanced Airbag performance

Changing the vehicle's suspension system can change the way that the Advanced Airbag System performs in a crash. For example, using tire-rim combinations not approved by Audi, lowering the vehicle, changing the stiffness of the suspension, including the springs, suspension struts, shock absorbers etc. can change the forces that are measured by the airbag sensors and sent to the electronic control unit. Some suspension changes can, for example, increase the force levels measured by the sensors and make the airbag system deploy in crashes in which it would not deploy if the changes had not been made. Other kinds of changes may reduce the force levels measured by the sensors and prevent the airbag from deploying when it should.

The sensors in the safety belt buckle for the driver and front passenger seat tell the electronic control module if the safety belt is latched or not. If the safety belt is being used, the front airbag will deploy at a slightly higher rate of vehicle deceleration than if the safety belt is not being used. Therefore, in a particular collision, it is possible that an airbag will not deploy at a seating position where the safety belt is being used but will inflate at the position where the safety belt is not being used. It is important that nothing interfere with the safety belt buckles so that the sensors can send the correct information about safety belt use to the electronic control unit.

WARNING

Changing the vehicle's suspension including use of unapproved tire-rim combinations can change Advanced Airbag per-

formance and increase the risk of serious personal injury in a crash.

- Never install suspension components that do not have the same performance characteristics as the components originally installed on your vehicle.
- Never use tire-rim combinations that have not been approved by Audi.

WARNING

Items stored between the safety belt buckle and the center console can cause the sensors in the buckle to send the wrong information to the electronic control module and prevent the Advanced Airbag System from working properly.

- Always make sure that nothing can interfere with the safety belt buckles and that they are not obstructed.

Knee airbags

Description of knee airbags

The knee airbag system can provide supplemental protection to properly restrained front seat occupants.



Fig. 169 Driver's knee airbag

The driver knee airbag is in the instrument panel underneath the steering wheel ⇒ *fig. 169*, the airbag for the passenger is at about the same height in the instrument panel underneath the glove compartment.

The knee airbag offers additional protection to the driver's and passenger's knees and upper and lower thigh areas and supplements the protection provided by the safety belts. ▶

If the front airbags deploy, the knee airbags also deploy in frontal collisions when the deployment threshold stored in the control unit is met ⇒ *page 162, More important things to know about front airbags.*

In addition to their normal safety function, safety belts help keep the driver or front passenger in position in a frontal collision so that the airbags can provide supplemental protection.

The airbag system is not a substitute for your safety belt. Rather, it is part of the overall occupant restraint system in your vehicle. Always remember that the airbag system can only help to protect you if you are wearing your safety belt and wearing it properly. This is why you should always wear your safety belt, not just because the law requires you to do so ⇒ *page 145, General notes.*

The safety belt buckle for the driver and front seat passenger have switches that tell the airbag control module if the safety belt is being used or not. If the safety belt is being used, the knee airbag will deploy at a slightly higher rate of deceleration than if the belt is not being used. Therefore, in a particular collision, it is possible that an airbag will not deploy at a seating position where the safety belt is being used but will inflate at the position where the safety belt is not being used.

Remember too, airbags will deploy only once and only in certain kinds of accidents - your safety belts are always there to offer protection in those accidents in which airbags are not supposed to deploy or when they have already deployed, for example when your vehicle strikes or is struck by another after the first collision.

This is just one of the reasons why an airbag is not a substitute for the safety belt. The airbag system works most effectively when used with the safety belts. Therefore, always wear your safety belts correctly.

It is important to remember that while the supplemental knee airbag system is designed to reduce the likelihood of serious injuries,

other injuries, for example, swelling, bruising and minor abrasions and friction burns can also occur when an airbag inflates.

The knee airbag system basically consists of:

- The electronic control module
- Two inflatable airbags (airbag and gas generator), one for the driver and one for the front passenger
- The airbag indicator light in the instrument panel

The knee airbag system will not deploy:

- when the ignition is switched off
- in frontal collisions when the deceleration measured by the control unit is too low
- in side collisions
- in rear-end collisions
- in rollovers
- in the event of a system malfunction (warning/indicator light is on) ⇒ *page 18.*



WARNING

- Safety belts and the airbag system can only provide protection when occupants are in the proper seating position ⇒ *page 162.*
- If the airbag indicator light ⇒ *page 18* comes when the vehicle is being used, have the system inspected immediately by your authorized Audi dealer. It is possible that the airbag will inflate when it is not supposed to, or will not inflate when it should.

How knee airbags work

The risk of injury to the leg area can be reduced by fully inflated knee airbags.

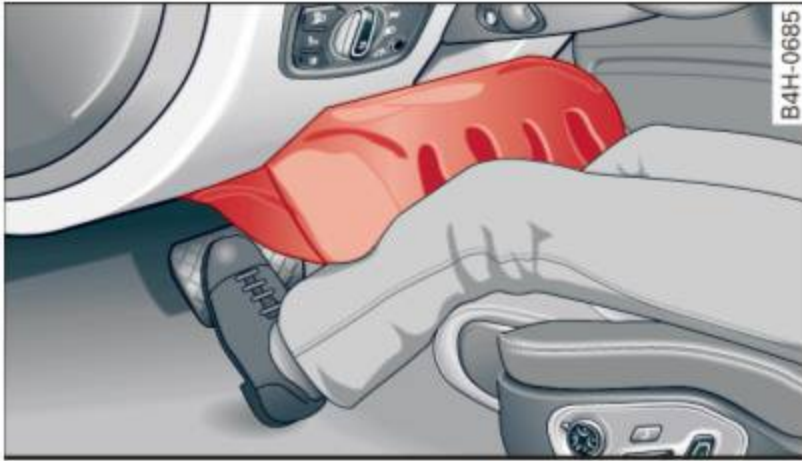

Fig. 170 Inflated airbags protecting in a frontal collision

The knee airbag system has been designed so that the airbags for the driver and front passenger deploy in certain but not all frontal collisions.

If the front airbags deploy, the knee airbags also deploy in frontal collisions when the deployment threshold stored in the control unit is met.

When the system deploys, the airbags fill with a propellant gas, and inflate between the lower part of the instrument panel and the driver and the lower part of the instrument panel and the front passenger ⇒ *page 162, fig. 167.*

Although they are not a soft pillow, they can “cushion” the impact and in this way they can help to reduce the risk of injury to the lower extremities.

All of this takes place in the blink of an eye, so fast that many people don't even realize that the airbags have deployed. The airbags also inflate with a great deal of force and it is important for occupant safety that nothing should be in their way when they deploy.

Fully inflated airbags in combination with properly worn safety belts slow down and limit the occupant's forward movement and help to reduce the risk of injury.

Important safety instructions on the knee airbag system

Airbags are only supplemental restraints. Always wear safety belts correctly and ride in a proper seating position.

There is a lot that you and your passengers must know and do to help the safety belts and airbags to provide supplemental protection.

WARNING

An inflating knee airbag can cause serious injury. Wearing safety belts incorrectly and improper seating positions increase the risk of serious personal injury and death whenever a vehicle is being used.

- The knee airbag system cannot protect you properly if you are seated too close to any of the airbag locations. When adjusting their seat positions, it is important that both the driver and the front passenger keep their upper bodies and knees at the following minimum safe distances:
 - at least 10 inches (25 cm) between the chest and the steering wheel/instrument panel.
 - at least 4 inches (10 cm) between the knees and the lower part of the instrument panel.
- The risk of personal injury increases if you lean forward or to the side, or if the seat is improperly positioned and you are not wearing your safety belt. The risk increases even more should the airbag deploy.
- Always make sure that the knee airbag can inflate without interference. Objects between you and the airbag can increase the risk of injury in an accident by interfering with the way the airbag deploys or by being pushed into you as the airbag deploys.
 - Never let anybody, especially children or animals ride in the footwell in front

of the passenger seat. If the airbag deploys, this can result in serious or fatal injuries.

- Never carry objects of any kind in the footwell area in front of the driver's or passenger's seat. Bulky objects (shopping bags, for example) can interfere with or prevent proper deployment of the airbag. Small objects can be thrown through the vehicle if the airbag deploys and injure you or your passengers.
- Make sure there are no cracks, deep scratches or other damage in the area of the instrument panel where the knee airbags are located.
- If children are incorrectly seated, their risk of injury increases in a collision
⇒ page 177, *Child Safety*.

Side airbags

Description of side airbags

The airbag system can provide supplemental protection to properly restrained occupants.



Fig. 171 Side airbag location in the driver's seat

The side airbags are located in the sides of the front seat backrests ⇒ *fig. 171* and the rear backrest facing the doors. They are identified by the word "AIRBAG".

The side airbag system basically consists of:

- the electronic control module and external side impact sensors
- the two side airbags located in the sides of the front backrests
- two rear side airbags

- the airbag warning light in the instrument cluster.

The airbag system is monitored electronically to make certain that it is functioning properly at all times. Each time you switch on the ignition, the airbag system indicator light will come on for a few seconds (self diagnostics).

The side airbag system supplements the safety belts and can help to reduce the risk of injury to the driver's, front and rear passenger's upper torso on the side of the vehicle that is struck in a side collision. The airbag deploys only in side impacts and only when the vehicle acceleration registered by the control unit is high enough. If this rate is below the reference value programmed into the control unit, the side airbags will not be triggered, even though the car may be badly damaged as a result of the collision. It is not possible to define an airbag triggering range that will cover every possible angle of impact, since the circumstances will vary considerably between one collision and another. Important factors include, for example, the nature (hard or soft) of the impacting object, the angle of impact, vehicle speed, etc. ⇒ page 173, *Important safety instructions on the side airbag system*.

Aside from their normal safety function, safety belts work to help keep the driver or front passenger in position in the event of a side collision so that the side airbags can provide protection.

The airbag system is *not* a substitute for your safety belt. Rather, it is part of the overall occupant restraint system in your vehicle. Always remember that the side airbag system can only help to protect you if you are wearing your safety belt and wearing it properly. This is another reason why you should always wear your safety belts, not just because the law requires you to do so ⇒ page 145, *General notes*.

It is important to remember that while the supplemental side airbag system is designed to reduce the likelihood of serious injuries, other injuries, for example, swelling, bruising, ►

and minor abrasions can also be associated with deployed side airbags. Remember too, side airbags will deploy only once and only in certain kinds of accidents - your safety belts are always there to offer protection.

Vehicle damage, repair costs or even the lack of vehicle damage are not necessarily an indication of over-sensitive or failed airbag activation. In some collisions, both front and side airbags may inflate. Remember too, that airbags will deploy only once and only in certain kinds of collisions - your safety belts are always there to offer protection in those accidents in which airbags are not supposed to deploy or when they have already deployed.

The side airbag system will not deploy:

- when the ignition is switched off
- in side collisions when the acceleration measured by the sensor is too low
- in front-end collisions
- in rear-end collisions
- in rollovers.

In some types of accidents the front airbags, side curtain airbags and side airbags may be triggered together.

! WARNING

- Safety belts and the airbag system will only provide protection when occupants are in the proper seating position ⇒ *page 173*.
- If the airbag indicator light ⇒ *page 18* comes when the vehicle is being used, have the system inspected immediately by your authorized Audi dealer. It is possible that the airbag will inflate when it is not supposed to, or will not inflate when it should.

How supplemental side airbags work

Side airbags deploy instantly and can help reduce the risk of upper torso injuries for occupants who are properly restrained.

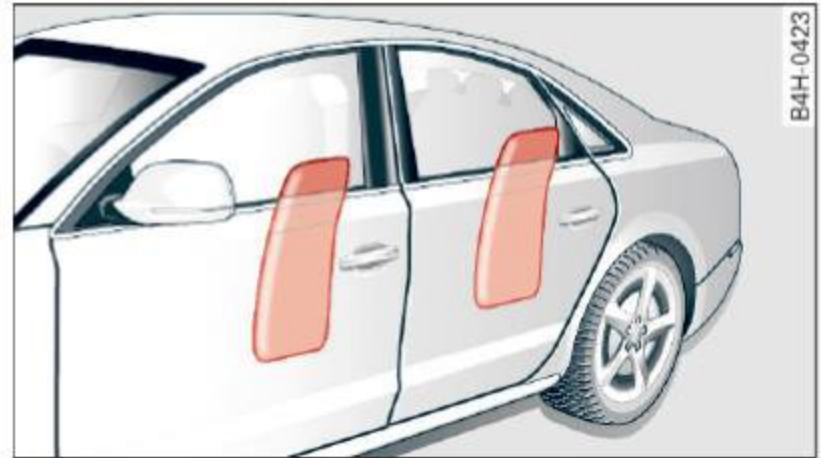

Fig. 172 Inflated side airbags on left side of vehicle, rear side airbag

When the system is triggered, the airbag is filled with propellant gas and breaks through a seam in the seat surface area marked "AIR-BAG". It expands between the side trim panel and the passenger. In order to help provide this additional protection, the side airbag must inflate within a fraction of a second at very high speed and with great force. The supplemental side airbag could injure you if your seating position is not proper or upright or if items are located in the area where the supplemental side airbag expands. This applies especially to children ⇒ *page 177, Child Safety*. Supplemental side airbags inflate between the occupant and the door panel on the side of the vehicle that is struck in certain side collision ⇒ *fig. 172*.

Although they are not a soft pillow, they can "cushion" the impact and in this way they can help to reduce the risk of injury to the upper part of the body.

A fine dust may develop when the airbag deploys. This is normal and does not mean there is a fire in the vehicle.

Important safety instructions on the side airbag system

Airbags are only supplemental restraints. Always properly wear safety belts and ride in a proper seating position.

There is a lot that you and your passengers must know and act accordingly to help the safety belts and airbags do their job to provide supplemental protection.

WARNING

An inflating side airbag can cause serious or fatal injury. Improperly wearing safety belts and improper seating positions increase the risk of serious personal injury and death whenever a vehicle is being used.

- In order to reduce the risk of injury when the supplemental side airbag inflates:
 - Always sit in an upright position and never lean against the area where the supplemental side airbag is located.
 - Never let a child or anyone else rest their head against the side trim panel in the area where the supplemental side airbag inflates.
 - Always make sure that safety belts are worn correctly,
 - Do not let anyone sitting in the front seat put their hand or any other parts of their body out of the window.
- Always make sure that the side airbag can inflate without interference.
 - Never install seat covers or replacement upholstery over the front seat-backs that have not been specifically approved by Audi.
 - Never use additional seat cushions that cover the areas where the side airbags deploy.
 - Damage to the original seat covers or to the seam in the area of the side airbag module must always be repaired immediately by an authorized Audi dealer.

- Objects between you and the airbag can increase the risk of injury in an accident by interfering with the way the airbag unfolds or by being pushed into you as the airbag inflates.
- Never place or attach accessories or other objects (such as cup holders, telephone brackets, or even large, bulky objects) on the doors, over or near the area marked “AIRBAG” on the seat backrests.
- Such objects and accessories can become dangerous projectiles and cause injury when the supplemental side airbag deploys.
- Never carry any objects or pets in the deployment space between them and the airbags or allow children or other passengers to travel in this position.
- Always use the built-in coat hooks only for lightweight clothing. Never leave any heavy or sharp-edged objects in the pockets that may interfere with side airbag deployment and can cause personal injury in an accident.
- Always prevent the side airbags from being damaged by heavy objects knocking against or hitting the sides of the seat-backs.
- The airbag system can only be triggered once. If the airbag has been triggered, the system must be replaced by an authorized Audi dealership.
- Damage (cracks, deep scratches etc.) to the original seat covers or to the seam in the area of the side airbag module must always be repaired immediately by an authorized Audi dealer.
- If children are seated improperly, their risk of injury increases in the case of an accident ⇒ *page 177, Child Safety*.
- Never attempt to modify any components of the airbag system in any way.
- In a side collision, side airbags will not function properly if sensors cannot correctly measure increasing air pressure inside the doors when air escapes through

larger, unclosed openings in the door panel.

- Never drive with interior door trim panels removed.
- Never drive when parts have been removed from the inside door panel and the openings they leave have not been properly closed.
- Never drive when loudspeakers in the doors have been removed unless the speaker holes have been properly closed.
- Always make certain that openings are covered or filled if additional speakers or other equipment is installed in the inside door panels.
- Always have work on the doors done by an authorized Audi dealer or qualified workshop.

Side curtain airbags

Description of side curtain airbags

The side curtain airbag system can provide supplemental protection to properly restrained occupants.

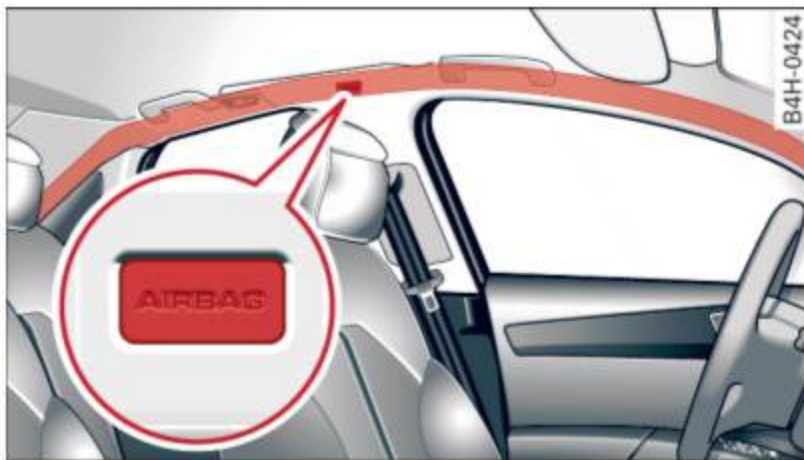

Fig. 173 Side curtain airbags, driver's side: side curtain airbag location

The side curtain airbags are located on both sides of the interior above the front and rear side windows ⇒ *fig. 173*. They are identified by the word “AIRBAG” on the windshield frame and the center roof pillar.

The side curtain airbag system supplements the safety belts and can help to reduce the risk of injury for occupants' heads and upper torso on the side of the vehicle that is struck

in a side collision. The side curtain airbag inflates in side impacts and only when the vehicle acceleration registered by the control unit is high enough. If this rate is below the reference value programmed into the control unit, the side airbags will not be triggered, even though the car may be badly damaged as a result of the collision. It is not possible to define an airbag triggering range that will cover every possible angle of impact, since the circumstances will vary considerably between one collision and another. Important factors include, for example, the nature (hard or soft) of the impacting object, the angle of impact, vehicle speed, etc. ⇒ *page 175, How side curtain airbags work*.

Aside from their normal safety function, safety belts work to help keep the driver or front passenger in position in the event of a collision so that the side curtain airbags can provide protection.

The airbag system is not a substitute for your safety belt. Rather, it is part of the overall occupant restraint system in your vehicle. Always remember that the airbag system can only help to protect you if you are wearing your safety belt and wearing it properly. This is another reason why you should always wear your safety belts, not just because the law requires you to do so ⇒ *page 145, General notes*.

It is important to remember that while the side curtain airbag system is designed to help reduce the likelihood of serious injuries, other injuries, for example, swelling, bruising, and minor abrasions can also be associated with these airbags upon deployment. Remember too, these airbags will deploy only once and only in certain kinds of accidents - your safety belts are always there to offer protection.

The side curtain airbag system basically consists of:

- The electronic control module and external side impact sensors
- The side curtain airbags above the front and rear side windows

- The airbag indicator light in the instrument panel

The airbag system is monitored electronically to make certain it is functioning properly at all times. Each time you switch on the ignition, the airbag system indicator light will come on for a few seconds (self diagnostics).

The side curtain airbag is not activated:

- if the ignition is switched off,
- in side collisions when the acceleration measured by the sensor is too low,
- in rear-end collisions,
- in rollovers.

WARNING

- Safety belts and the airbag system will only provide protection when occupants are in the proper seating position ⇒ *page 58, General recommendations.*
- If the airbag indicator light ⇒ *page 18* comes when the vehicle is being used, have the system inspected immediately by your authorized Audi dealer. It is possible that the airbag will inflate when it is not supposed to, or will not inflate when it should.

How side curtain airbags work

Side curtain airbags can work together with side airbags to help reduce the risk of head and upper torso injuries for occupants who are properly restrained.

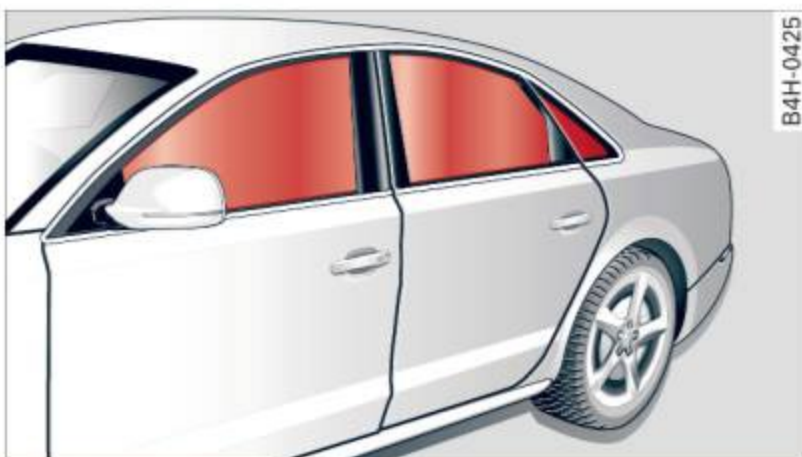

Fig. 174 Illustration of principle: Inflated side curtain airbags on the left side

The side curtain airbags inflate between the occupant and the windows on the side of the

vehicle that is struck in a side collision ⇒ *fig. 174.*

When the system is triggered, the side curtain airbag is filled with propellant gas and breaks through a seam above the front and rear side windows identified by the AIRBAG label. In order to help provide this additional protection, the side curtain airbag must inflate within the blink of an eye at very high speed and with great force. The side curtain airbag could injure you if your seating position is not proper or upright or if items are located in the area where the supplemental side curtain airbag inflates. This applies especially to children ⇒ *page 177.*

Although they are not a soft pillow, side curtain airbags can “cushion” the impact and in this way they can help to reduce the risk of injury to the head and the upper part of the body.

A fine dust may develop when the airbag deploys. This is quite normal and does not mean there is a fire in the vehicle.

Important safety instructions on the side curtain airbag system

Airbags are only supplemental restraints. Always properly wear safety belts and ride in a proper seating position.

There is a lot that you and your passengers must know and do to help the safety belts and airbags do their job to provide supplemental protection.

WARNING

- Improperly wearing safety belts and improper seating positions increase the risk of serious personal injury and death whenever a vehicle is being used.
- Never let occupants place any parts of their bodies in the area from which the side curtain airbags inflate.
- Always make sure that the side curtain airbags can inflate without interference. Unsuitable accessories fitted inside the

expansion range of a side curtain airbag can dangerously interfere with its function. A deploying head airbag develops enough force to catapult any piece of add-on component out of its path of inflation and into the passenger compartment. An occupant hit by such a projectile can suffer serious injury or death
⇒ *page 295, Technical Modifications.*

- Do not swivel the sun visors to the side if you have any objects clipped onto them (for example pens). If the airbag should deploy, you could be injured by these objects.
- Use the built-in coat hooks only for lightweight clothing. Never leave any heavy or sharp-edged objects in the pockets that may interfere with airbag deployment and can cause personal injury in an accident.
- Never use hangers to hang clothing from the hooks.
- Only use factory-installed sun shades or, in the case of shades installed after the vehicle leaves the factory, only Audi roll-up sunscreens may be used ⇒ *page 294, Additional accessories and parts replacement.*
- Always sit in proper seating position and wear safety belts while traveling so that the side curtain airbags can help provide protection.
- The airbag system can only be triggered once. If the airbag has been triggered, the system must be replaced by an authorized Audi dealer or qualified workshop.
- Always have work involving the side curtain airbag system, removal and installation of the airbag components, or other repairs performed by a qualified dealership. Otherwise the airbag system may not work correctly.
- Never attempt to modify any components of the airbag system in any way.

Child Safety

Important things to know

Introduction

The rear seat is generally the safest place in a collision.

The physical principles of what happens when your vehicle is in a crash apply also to children ⇒ *page 146, What happens to occupants not wearing safety belts?*. But unlike adults and teenagers, their muscles and bones are not fully developed. In many respects children are at greater risk of serious injury in crashes than adults.

Because children's bodies are not fully developed, they require restraint systems especially designed for their size, weight, and body structure. Many countries and all states of the United States and provinces of Canada have laws requiring the use of approved child restraint systems for infants and small children.

In a frontal crash at a speed of 20-35 mph (30-56 km/h) the forces acting on a 13-pound (6 kg) infant will be more than 20 times the weight of the child. This means the weight of the child would suddenly be more than 260 pounds (120 kg). Under these conditions, only an appropriate child restraint properly used can reduce the risk of serious injury. Child restraints, like adult safety belts, must be used properly to be effective. Used improperly, they can increase the risk of serious injury in an accident.

Consult the child safety seat manufacturer's instructions in order to be sure the seat is right for your child's size ⇒ *page 180, Important safety instructions for using child safety seats*. Please be sure to read and heed all of the important information and WARNINGS about child safety, Advanced Airbags, and the installation of child restraints in this chapter.

There is a lot you need to know about the Advanced Airbags in your vehicle and how they work when infants and children in child re-

straints are on the front passenger seat. Because of the large amount of important information, we cannot repeat it all here. We urge you to read the detailed information in this owner's manual about airbags and the Advanced Airbag System in your vehicle and the very important information about transporting children on the front passenger seat. Please be sure to heed the WARNINGS - they are extremely important for your safety and the safety of your passengers, especially infants and small children.

WARNING

- Accident statistics have shown that children are generally safer in the rear seat area than in the front seating position. Always restrain any child age 12 and under in the rear.
- All vehicle occupants and especially children must be restrained properly whenever riding in a vehicle. An unrestrained or improperly restrained child could be injured by striking the interior or by being ejected from the vehicle during a sudden maneuver or impact. An unrestrained or improperly restrained child is also at greater risk of injury or death through contact with an inflating airbag.
- A suitable child restraint properly installed and used at one of the rear seating positions provides the highest degree of protection for infants and small children in most accident situations.

WARNING

- Children on the front seat of any car even with Advanced Airbags can be seriously injured or even killed when an airbag inflates. A child in a rearward-facing child safety seat installed on the front passenger seat will be seriously injured and can be killed if the front airbag inflates.
- The inflating airbag will hit the child safety seat or infant carrier with great force and will smash the child safety seat and child against the backrest, center armrest, or door.

- Always install rear-facing child safety seats on the rear seat.
- If you must install a rearward facing child safety seat on the front passenger seat in exceptional circumstances and the **PASSENGER AIR BAG OFF** light does not come on and stay on, immediately install the rear-facing child safety seat in a rear seating position and have the air-bag system inspected immediately by your Audi dealer.

WARNING

If, in exceptional circumstances, you must install a forward-facing child restraint on the front passenger's seat:

- Always make sure the forward-facing seat has been designed and certified by its manufacturer for use on a front seat with a passenger front and side airbag.
- Always follow the manufacturer's instructions provided with the child safety seat or carrier.
- Always move the passenger seat into its rearmost position in the seat's fore and aft adjustment range, as far away from the airbag as possible before installing the child restraint. The backrest must be adjusted to an upright position.
- Always make sure that the **PASSENGER AIR BAG OFF** light comes on and stays on all the time whenever the ignition is switched on.

Tips

Always replace child restraints that were installed in a vehicle during a crash. Damage to a child restraint that is not visible could cause it to fail in another collision situation.

Advanced front airbag system and children

Your vehicle is equipped with a front “Advanced Airbag System” in compliance with United States Federal Motor Vehicle Safety

Standard (FMVSS) 208 as applicable at the time your vehicle was manufactured.

The Advanced Airbag system in your vehicle has been certified to meet the “low-risk” requirements for 3- and 6-year old children on the passenger side and small adults on the driver side. The low risk deployment criteria are intended to reduce the risk of injury through interaction with the airbag that can occur, for example, by being too close to the steering wheel and instrument panel when the airbag inflates. In addition, the system has been certified to comply with the “suppression” requirements of the Safety Standard, to turn off the front airbag for infants up to 12 months who are restrained on the front passenger seat in child restraints that are listed in the Standard.

Even though your vehicle is equipped with an Advanced Airbag system, all children, especially those 12 years and younger, should always ride in the back seat properly restrained for their age and size. The airbag on the passenger side makes the front seat a potentially dangerous place for a child to ride. The front seat is not the safest place for a child in a forward-facing child safety seat. It can be a very dangerous place for an infant or a larger child in a rearward-facing seat.

Advanced Airbags and the weight-sensing mat in the front seat

The Advanced Airbag System in your vehicle detects the presence of an infant or child in a child restraint on the front passenger seat using the weight-sensing mat in the seat cushion and the sensor below the safety belt latch on the front passenger seat that measures the tension on the safety belt.

The weight-sensing mat measures total weight of the child and the child safety seat and a child blanket on the front passenger seat. The weight on the front passenger seat is related to the design of the child restraint and its “footprint”, the size and shape of the bottom of the child restraint as it sits on the

seat. The weight of a child restraint and its “footprint” vary for different kinds of child restraints and for the different models of the same kind of child restraint offered by child restraint manufacturers.

The weight ranges for the individual types, makes and models of child restraints that the NHTSA has specified in the Safety Standard together with the weight ranges of typical infants and typical 1 year-old child have been stored in the control unit of the Advanced Airbag System. When a child restraint is being used on the front passenger seat with a typical 1 year-old child, the Advanced Airbag System compares the weight measured by the weight sensing mat with the information stored in the electronic control unit.

The electronic control unit also registers the tension on the front passenger safety belt. The tension on the safety belt for the front passenger seat will be different for an adult who is properly using the safety belt as compared to the tension on the belt when it is used to attach a child restraint to the seat. The sensor below the latch for the safety belt for the front seat passenger measures the tension on the belt. The input from this sensor is then used with the weight to “decide”, whether there is a child restraint with a typical 1 year-old child on the front passenger seat and whether or not the airbag must be turned off.

Child restraints and Advanced Airbags

Regardless of the child restraint that you use, make sure that it has been certified to meet United States Federal Motor Vehicle Safety Standards and has been certified by its manufacturer for use with an airbag. Always be sure that the child restraint is properly installed at one of the rear seating positions. If in exceptional circumstances you must use it on the front passenger seat, carefully read all of the information on child safety and Advanced Airbags and heed all of the applicable WARNINGS. Make certain that the child restraint is correctly recognized by the weight-sensing

mat inside the front passenger seat, that the front passenger airbag is turned off and that the airbag status is always correctly signaled by the **PASSENGER AIR BAG OFF** light.

Many types and models of child restraints have been available over the years, new models are introduced regularly incorporating new and improved designs and older models are taken out of production. Child restraints are not standardized. Child restraints of the same type typically have different weights and sizes and different 'footprints,' the size and shape of the bottom of the child restraint that sits on the seat, when they are installed on a vehicle seat. These differences make it virtually impossible to certify compliance with the requirements for advanced airbags with each and every child restraint that has ever been sold in the past or will be sold over the course of the useful life of your vehicle.

For this reason, the United States National Highway Traffic Safety Administration has published a list of specific type, makes and models of child restraints that must be used to certify compliance of the Advanced Airbag System in your vehicle with the suppression requirements of Federal Motor Vehicle Safety Standard 208. These child restraints are:

Subpart A – Car bed child restraints

Model	Manufactured on or after
Angel Guard Angel Ride AA2403FOF	September 25, 2007

Subpart B – Rear-facing child restraints

Model	Manufactured on or after
Century SmartFit 4543	December 1, 1999
Cosco Arriva 22-013PAW and base 22-999WHO	September 25, 2007
Evenflo Discovery Adjust Right 212	December 1, 1999

Model	Manufactured on or after
Evenflo First Choice 204	December 1, 1999
Graco Infant 8457	December 1, 1999
Graco Snugride	September 25, 2007
Peg Perego Primo Viaggio SIP IMUN00US	September 25, 2007

Subpart C – Forward-facing and convertible child restraints

Model	Manufactured on or after
Britax Roundabout E9L02xx	September 25, 2007
Cosco Touriva 02519	December 1, 1999
Cosco Summit Deluxe High Back Booster 22-262	September 25, 2007
Cosco High Back Booster 22-209	September 25, 2007
Evenflo Tribute V 379xxxx	September 25, 2007
Evenflo Medallion 254	December 1, 1999
Evenflo Generations 352xxxx	September 25, 2007
Graco ComfortSport	September 25, 2007
Graco Toddler Safety Seat Step 2	September 25, 2007
Graco Platinum Cargo	September 25, 2007

WARNING

To reduce the risk of serious injury, make sure that the **PASSENGER AIR BAG OFF** light comes on and stays on whenever a child restraint is installed on the front passenger seat and the ignition is switched on.

- Take the child restraint off the front passenger seat and install it properly at one of the rear seat positions if the **PASSENGER AIR BAG OFF** light does not stay on.

- Have the airbag system inspected by your authorized Audi dealer immediately.

Tips

The child seats listed in categories A to C have been statically tested by Audi only for the Advanced Airbag function.

Important safety instructions for using child safety seats

Correct use of child safety seats substantially reduces the risk of injury in an accident!

As the driver, you are responsible for the safety of everybody in the vehicle, especially children:

- ▶ Always use the right child safety seat for each child and always use it properly ⇒ *page 183*.
- ▶ Always carefully follow the child safety seat manufacturer's instructions on how to route the safety belt properly through the child safety seat.
- ▶ When using the vehicle safety belt to install a child safety seat, you must first activate the convertible locking retractor on the safety belt to prevent the child safety seat from moving ⇒ *page 187*.
- ▶ Push the child safety seat down with your full weight to get the safety belt really tight so that the seat cannot move forward or sideways more than one inch (2.5 cm).
- ▶ If a strap or tether is being used to tie the child safety seat to the front passenger seat, make sure that it is not so tight that it causes the weight-sensing mat to measure more weight than is actually on the seat.
- ▶ Secure unused safety belts on the rear seat ⇒ *page 182*.

Always remember: Even though your vehicle is equipped with an Advanced Airbag system, all children, especially those 12 years and younger, should always ride in the back seat properly restrained for their age and size. ▶

! WARNING

Not using a child safety seat, using the wrong child safety seat or improperly installing a child restraint increases the risk of serious personal injury and death.

- All vehicle occupants and especially children must always be restrained properly whenever riding in a vehicle.
 - An unrestrained or improperly restrained child can be injured or killed by being thrown against the inside of the vehicle or by being ejected from it during a sudden maneuver or impact.
 - An unrestrained or improperly restrained child is at much greater risk of injury or death by being struck by an inflating airbag.
- Commercially available child safety seats are required to comply with U.S. Federal Motor Vehicle Safety Standard (FMVSS) 213 (in Canada CMVSS 213).
 - When buying a child restraint, select one that fits your child and the vehicle.
 - Only use child restraint systems that fully contact the flat portion of the seat cushion. The child restraint must not tip or lean to either side. Audi does not recommend using child safety seats that rest on legs or tube-like frames. They do not provide adequate contact with the seat.
 - Always heed all legal requirements pertaining to the installation and use of child safety seats and carefully follow the instructions provided by the manufacturer of the seat you are using.
- Never allow children under 57 inches (1.45 meters) to wear a normal safety belt. They must always be restrained by a proper child restraint system. Otherwise, they could sustain injuries to the abdomen and neck areas during sudden braking maneuvers or accidents.
- Never let more than one child occupy a child safety seat.

- Never let babies or older children ride in a vehicle while sitting on the lap of another passenger.
 - Holding a child in your arms is never a substitute for a child restraint system.
 - The strongest person could not hold the child with the forces that exist in an accident. The child will strike the interior of the vehicle and can also be struck by the passenger.
 - The child and the passenger can also injure each other in an accident.
- Never install rear-facing child safety seats or infant carriers on the front passenger seat. A child will be seriously injured and can be killed when the passenger airbag inflates – even with an Advanced Airbag System.
- The inflating airbag will hit the child safety seat or infant carrier with great force and will smash the child safety seat and child against the backrest, center armrest, door or roof.
- Always install rear-facing child safety seats or infant carriers on the rear seat.
- Forward-facing child safety seats installed on the front passenger's seat can interfere with the airbag when it inflates and cause serious injury to the child. Always install forward-facing child safety seats on the rear seat.
- If exceptional circumstances require the use of a forward-facing child restraint on the front passenger's seat, the child's safety and well-being require that the following special precautions be taken:
 - Make sure the forward-facing seat has been designed and certified by its manufacturer for use on a front seat with a passenger front and side airbag.
 - Always carefully follow the manufacturer's instructions provided with the child safety seat or carrier.
 - Always move the front passenger seat into the rearmost position of the passenger seat's fore and aft adjustment range, and as far away from the airbag

as possible before installing the child restraint.

- Always make sure that nothing prevents the front passenger's seat from being moved to the rearmost position in its fore and aft adjustment range.
- Always make sure that the backrest is in the upright position.
- Always buckle the child safety seat firmly in place even if a child is not sitting in it. A loose child safety seat can fly around during a sudden stop or in a collision.
- Always read and heed all WARNINGS whenever using a child restrained in a vehicle is being used ⇒ *page 145, Safety belts*, ⇒ *page 153, Airbag system* and ⇒ *page 177, Child Safety*.

WARNING

- To reduce the risk of serious injury, make sure that the **PASSENGER AIR BAG OFF** light comes on and stays on whenever a child restraint is installed on the front passenger seat and the ignition is switched on.
- Take the child restraint off the front passenger seat and install it properly at one of the rear seat positions if the **PASSENGER AIR BAG OFF** light does not stay on.
 - Have the airbag system inspected by your authorized Audi dealer immediately.

Secure unused safety belts on the rear seat



Fig. 175 Schematic overview: keep unused safety belts away from children in child safety seats. **A** - outer rear safety belt, **B** - center rear safety belt

If a child safety seat is used on the rear bench, especially with LATCH universal lower anchorages, the unused safety belts **must** be secured so that the child in the child restraint cannot reach them ⇒ .

- Guide the safety belt webbing behind the head restraint of the adjacent seat ⇒ *fig. 175*. When doing so, do not engage the switchable locking retractor! You should not hear a “clicking” sound when winding up the safety belt.
- Let the belt retractor wind up the safety belt webbing.

WARNING

A child in a child safety seat installed with the LATCH lower anchorages or with the standard safety belt or a child in a booster seat on the rear seat could play with unused rear seat safety belts and become entangled. This could cause the child serious personal injury and even death.

- Always secure unused rear seat safety belts out of reach of children in child seats such as by properly routing them around the head restraint of the seat where the child restraint is installed.
- Never activate the switchable locking retractor when routing the safety belts around the head restraints.
- Never let anyone sit at the center rear seating position if the center rear safety belt has been routed around a rear head restraint.

Child safety seats

Infant seats

Babies and infants up to about one year old and 20 lbs. or 9 kg need special rearward-facing child restraints that support the back, neck and head in a crash.

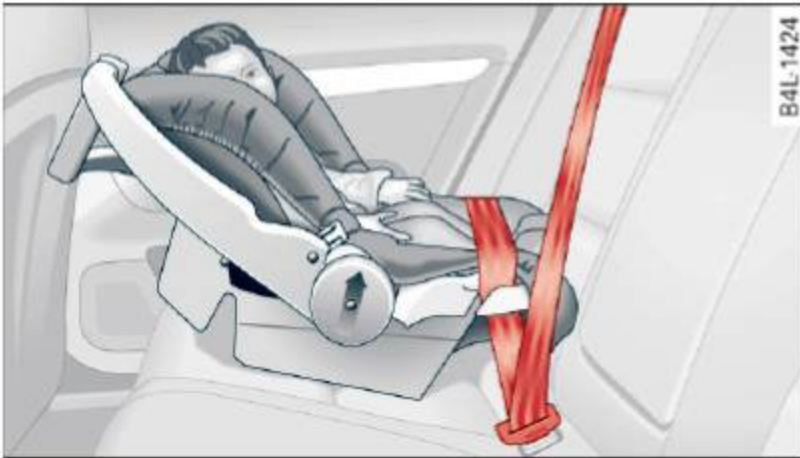

Fig. 176 Schematic overview: rearward-facing infant seat, properly installed on the rear seat

- ▶ When using the vehicle safety belt to install a child safety seat, you must first activate the convertible locking retractor on the safety belt to prevent the child safety seat from moving ⇒ *page 187* or install the seat using the LATCH attachments.
- ▶ Push the child safety seat down with your full weight to get the safety belt really tight so that the seat cannot move forward or sideways more than one inch (2.5 cm).
- ▶ Secure unused safety belts on the rear seat ⇒ *page 182*.

Infants up to about one year (20 lbs. or 9 kg) are best protected in special infant carriers and child safety seats designed for their age group. Many experts believe that infants and small children should ride only in special restraints in which the child faces the back of the vehicle. These infant seats support the baby's back, neck and head in a crash ⇒ *fig. 176*.

The airbag on the passenger side makes the front seat a potentially dangerous place for a child to ride. The front seat is not the safest place for a child in a forward-facing child seat. It is a very dangerous place for an infant or a larger child in a rearward-facing seat.

WARNING

Not using a child safety seat, using the wrong child safety seat or improperly installing a child restraint increases the risk of serious personal injury and death in a crash.

- Never install rear-facing child safety seats or infant carriers on the front passenger seat - even with an Advanced Airbag System. A child will be seriously injured and can be killed when the inflating airbag hits the child safety seat or infant carrier with great force and smashes the child safety seat and child against the backrest, center armrest, door or roof ⇒ *page 155, Child restraints on the front seat - some important things to know*.
- Always install rear-facing child safety seats or infant carriers on the rear seat.
- Never install a rear-facing child restraint in the forward-facing direction. Such restraints are designed for the special needs of infants and very small children and cannot protect them properly if the seat is forward-facing.
- If you must install a rearward facing child safety seat on the front passenger seat because of exceptional circumstances and the **PASSENGER AIR BAG OFF** light does not come on and stay on, immediately install the rear-facing child safety seat in a rear seating position and have the airbag system inspected by your Audi dealer.
- Always read and heed all WARNINGS whenever using a child restrained in a vehicle is being used ⇒ *page 145, Safety belts*, ⇒ *page 153, Airbag system* and ⇒ *page 177, Important things to know*.

Convertible child safety seats

Properly used convertible child safety seats can help protect toddlers and children over age one who weigh between 20 and 40 lbs. (9 and 18 kg) in a crash.



Fig. 177 Schematic overview: installation of the attachments applicable to a LATCH seat

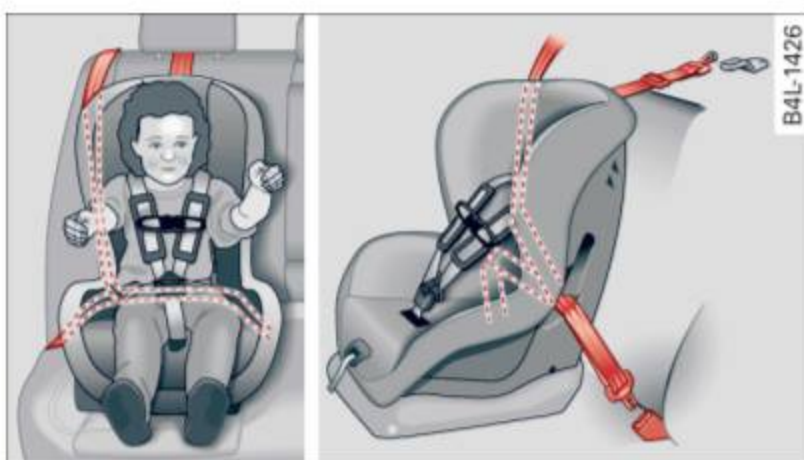

Fig. 178 Schematic overview: installation of the seat using the vehicle's safety belt system

- ▶ When using the vehicle safety belt to install a child safety seat, you must first activate the convertible locking feature on the safety belt to prevent the child safety seat from moving ⇒ *page 187* or install the seat using the LATCH attachments.
- ▶ Push the child safety seat down with your full weight to get the safety belt really tight so that the seat cannot move forward or sideways more than one inch (2.5 cm) ⇒ *page 187*.
- ▶ If the child safety seat is equipped with a tether strap, attach it to the tether anchors ⇒ *page 194*.
- ▶ Secure unused safety belts on the rear seat ⇒ *page 182*.

A toddler or child is usually too large for an infant restraint if it is more than one year old and weighs more than 20 lbs. (9 kg).

Toddlers and children who are older than one year up to about 4 years old and weigh more than 20 lbs (9 kg) up to 40 lbs. (18 kg) must always be properly restrained in a child safety seat certified for their size and weight ⇒ *fig. 177* and ⇒ *fig. 178*.

The airbag on the passenger side makes the front seat a potentially dangerous place for a child to ride. The front seat is not the safest place for a child in a forward-facing child safety seat. It is a very dangerous place for an infant or a larger child in a rearward-facing seat.

! WARNING

Not using a child safety seat, using the wrong child safety seat or improperly installing a child restraint increases the risk of serious personal injury and death in a collision or other emergency situation.

- Children on the front seat of any car, even with Advanced Airbags, can be seriously injured or even killed when an airbag inflates. A child in a rearward-facing child safety seat installed on the front passenger seat will be seriously injured and can be killed if the front airbag inflates – even with an Advanced Airbag System.
- The inflating airbag will hit the child safety seat or infant carrier with great force and will smash the child safety seat and child against the backrest, center arm rest, door or roof.
- Always install rear-facing child safety seats on the rear seat.
- If you must install a rearward facing child safety seat on the front passenger seat because of exceptional circumstances and the **PASSENGER AIR BAG OFF** light does not come on and stay on, immediately install the rear-facing child safety seat in a rear seating position and have the airbag system inspected by your Audi dealer.
- The rear side of the child safety seat should be positioned as close as possible

to the backrest on the vehicle seat. Adjust the rear seat head restraint if it is difficult to install the child seat with the head restraint in place ⇒ *page 139*. Driving with head restraints that are not properly adjusted increases the risk of serious or fatal neck injury dramatically.

- Always read and heed all **WARNINGS** whenever using a child restrained in a vehicle is being used ⇒ *page 145, Safety belts*, ⇒ *page 153, Airbag system* and ⇒ *page 177, Important things to know*.

WARNING

If exceptional circumstances require the use of a forward-facing child restraint on the front passenger's seat, the child's safety and well-being require that the following special precautions be taken:

- Make sure the forward-facing seat has been designed and certified by its manufacturer for use on a front seat with a passenger front and side airbag.
- Always follow the manufacturer's instructions provided with the child safety seat or infant carrier.
- Always move the front passenger seat into the rearmost position of the passenger seat's fore and aft adjustment range, and as far away from the airbag as possible before installing the child restraint.
- Always make sure that nothing prevents the front passenger's seat from being moved to the rearmost position in its fore and aft adjustment range.
- Always make sure the backrest is in an upright position.
- Make sure that the **PASSENGER AIR BAG OFF** light comes on and stays on all the time whenever the ignition is switched on.
- If the light does not stay on, perform the checks ⇒ *page 164, Monitoring the Advanced Airbag System*.
- Take the child restraint off the front passenger seat and install it properly at one of the rear seat positions if the **PASSEN-**

GER AIR BAG OFF light does not stay on whenever the ignition is switched on.

Booster seats and safety belts

Properly used booster seats can help protect children weighing between about 40 lbs. and 80 lbs. (18 kg and 36 kg) who are less than 4 ft. 9 in. (57 inches/1.45 meters) tall.



Fig. 179 Rear seat: child properly restrained in a booster seat

The vehicle's safety belts alone will not fit most children until they are at least 4 ft. 9 in. (57 inches/1.45 meters) tall and weigh about 80 lbs. (36 kg). Booster seats raise these children up so that the safety belt will pass properly over the stronger parts of their bodies and the safety belt can help protect them in a crash.

- ▶ Do not use the convertible locking retractor when using the vehicle's safety belt to restrain a child on a booster seat.
- ▶ The shoulder belt must lie as close to the center of the child's collar bone as possible and must lie flat and snug on the upper body. It must never lie across the throat or neck. The lap belt must lie across the pelvis and never across the stomach or abdomen. Make sure the belt lies flat and snug. Pull on the belt to tighten if necessary.
- ▶ If you must transport an older child in a booster seat on the front passenger seat, you can use the safety belt height adjustment to help adjust the shoulder portion properly.
- ▶ Secure unused safety belts on the rear seat ⇒ *page 182*.

Children up to at least 8 years old (over 40 lbs or 18 kg) are best protected in child safety seats designed for their age and weight. Experts say that the skeletal structure, particularly the pelvis, of these children is not fully developed, and they must not use the vehicle safety belts without a suitable child restraint.

It is usually best to put these children in appropriate booster seats. Be sure the booster seat meets all applicable safety standards.

Booster seats raise the seating position of the child and reposition both the lap and shoulder parts of the safety belt so that they pass across the child's body in the right places. The routing of the belt over the child's body is very important for the child's protection, whether or not a booster seat is used. Children age 12 and under must always ride in the rear seat.

Children who are at least 4 ft. 9 in. (57 inches/1.45 meters) tall can generally use the vehicle's three point lap and shoulder belts. Never use the lap belt portion of the vehicle's safety belt alone to restrain any child, regardless of how big the child is. Always remember that children do not have the pronounced pelvic structure required for the proper function of lap belt portion of the vehicle's three point lap and shoulder belts. The child's safety absolutely requires that a lap belt portion of the safety belt be fastened snugly and as low as possible around the pelvis. Never let the lap belt portion of the safety belt pass over the child's stomach or abdomen.

In a crash, airbags must inflate within a blink of an eye and with considerable force. In order to do its job, the airbag needs room to inflate so that it will be there to protect the occupant as the occupant moves forward into the airbag.

A vehicle occupant who is out of position and too close to the airbag gets in the way of an inflating airbag. When an occupant is too close, he or she will be struck violently and will receive serious or possibly even fatal injury.

In order for the airbag to offer protection, it is important that all vehicle occupants, especially any children, who must be in the front seat because of exceptional circumstances, be properly restrained and as far away from the airbag as possible. By keeping room between the child's body and the front of the passenger compartment, the airbag can inflate completely and provide supplemental protection in certain frontal collisions.

 **WARNING**

Not using a booster seat, using the booster seat improperly, incorrectly installing a booster seat or using the vehicle safety belt improperly increases the risk of serious personal injury and death in a collision or other emergency situation. To help reduce the risk of serious personal injury and/or death:

- The shoulder belt must lie as close to the center of the child's collar bone as possible and must lie flat and snug on the upper body. It must never lie across the throat or neck. The lap belt must lie across the pelvis and never across the stomach or abdomen. Make sure that the belt lies flat and snug. Pull on the belt to tighten if necessary.
- Failure to properly route safety belts over a child's body will cause severe injuries in an accident or other emergency situation ⇒ *page 145*.
- The rear side of the child safety seat should be positioned as close as possible to the backrest on the vehicle seat. Adjust the rear seat head restraint if it is difficult to install the child seat with the head restraint in place ⇒ *page 139*. Driving with head restraints that are not properly adjusted increases the risk of serious or fatal neck injury dramatically.
- Children on the front seat of any car, even with Advanced Airbags, can be seriously injured or even killed when an airbag inflates.
- Never let a child stand or kneel on any seat, for example the front seat.

- Never let a child ride in the cargo area of your vehicle.
- Always remember that a child leaning forward, sitting sideways or out of position in any way during an accident can be struck by a deploying airbag. This will result in serious personal injury or death.
- If you must install a booster seat on the front passenger seat because of exceptional circumstances the **PASSENGER AIR BAG OFF** light must come on and stay on, whenever the ignition is switched on.
- If the **PASSENGER AIR BAG OFF** light does not come on and stay on, perform the checks described ⇒ *page 164, Monitoring the Advanced Airbag System*.
- Take the child restraint off the front passenger seat and install it properly at one of the rear seat positions if the **PASSENGER AIR BAG OFF** light does not stay on whenever the ignition is switched on.
- Always read and heed all WARNINGS whenever using a child restrained in a vehicle is being used ⇒ *page 145, Safety belts*, ⇒ *page 153, Airbag system* and ⇒ *page 177, Important things to know*.

Installing a child safety seat

Securing a child safety seat using a safety belt

Safety belts for the rear seats and the front passenger can be locked with the convertible locking retractor to properly secure child safety seats.

The safety belts emergency locking retractors for the rear seats safety belts and for the front passenger's seat safety belt have a convertible locking retractor for child restraints. The safety belt must be locked so that belt webbing cannot unreel. The retractor can be activated to lock the safety belt and prevent the safety belt webbing from loosening up during normal driving. A child safety seat can only be properly installed when the safety belt

is locked so that the child and child safety seat will stay in place.

Always remember: Even though your vehicle is equipped with an Advanced Airbag system, all children, especially those 12 years and younger, should always ride in the back seat properly restrained for their age and size.



WARNING

Improperly installed child safety seats increase the risk of serious personal injury and death in a collision.

- Always make sure that the safety belt retractor is locked when installing a child safety seat. An unlocked safety belt retractor cannot hold the child safety seat in place during normal driving or in a crash.
- Always buckle the child safety seat firmly in place even if a child is not sitting in it. A loose child safety seat can fly around during a sudden stop or in a collision.
- Always make sure that the rear seat backrest to which the center rear safety belt is attached is securely latched whenever the rear center safety belt is being used to secure a child restraint.
- If the backrest is not securely latched, the child and the child restraint will be thrown forward together with the backrest and will strike parts of the vehicle interior. The child can be seriously injured or killed.
- Never install rear-facing child safety seats or infant carriers on the front passenger seat. A child will be seriously injured and can be killed when the passenger airbag inflates.
- The inflating airbag will hit the child safety seat or infant carrier with great force and will smash the child safety seat and child against the backrest, center armrest, door or roof.
- Always install rear-facing child safety seats or infant carriers on the rear seat.

- Forward-facing child safety seats or infant carriers installed on the front passenger's seat may interfere with the deployment of the airbag and cause serious injury to the child.
- It is safer to install a forward-facing child safety seat on the rear seat.
- Always read and heed all WARNINGS whenever using a child restrained in a vehicle is being used ⇒ *page 177*. Special precautions apply when installing a child safety seat on the front passenger seat ⇒ *page 155, Child restraints on the front seat – some important things to know*.

 **WARNING**

- Always take special precautions if you must install a forward or rearward-facing child restraint on the front passenger's seat in exceptional situations:
- Whenever a forward or rearward-facing child restraint is installed on the front passenger seat, the **PASSENGER AIR BAG OFF** light must come on and stay on whenever the ignition is switched on.
 - If the **PASSENGER AIR BAG OFF** light does not come on and stay on, perform the checks described ⇒ *page 164, Monitoring the Advanced Airbag System*.
 - Take the child restraint off the front passenger seat and install it properly at one of the rear seat positions if the **PASSENGER AIR BAG OFF** light does not stay on whenever the ignition is switched on.
 - Improper installation of child restraints can reduce their effectiveness or even prevent them from providing any protection.
 - An improperly installed child restraint can interfere with the airbag as it deploys and seriously injure or even kill the child.
 - Always carefully follow the manufacturer's instructions provided with the child safety seat or carrier.
 - Never place additional items on the seat that can increase the total weight regis-

tered by the weight-sensing mat and can cause injury in a crash.

 **WARNING**

Forward-facing child restraints:

- Always make sure the forward-facing seat has been designed and certified by its manufacturer for use on a front seat with a passenger front and side airbag.
- Never put the forward-facing child restraint up, against or very near the instrument panel.
- Always move the passenger seat into its rearmost position in the seat's fore and aft adjustment range, as far away from the airbag as possible before installing the forward-facing child restraint. The backrest must be adjusted to an upright position.
- Make sure that the **PASSENGER AIR BAG OFF** light comes on and stays on all the time whenever the ignition is switched on.

 **WARNING**

Rearward-facing child restraints:

- A child in a rearward-facing child safety seat installed on the front passenger seat will be seriously injured and can be killed if the front airbag inflates - even with an Advanced Airbag System.
- The inflating airbag will hit the child safety seat or infant carrier with great force and will smash the child safety seat and child against the backrest, center armrest, door or roof.
- Always be especially careful if you must install a rearward facing child safety seat on the front passenger seat in exceptional circumstances.
- A tight tether strap on a rearward-facing child restraint attached to the front passenger seat can put too much pressure on the weight-mat in the seat and register a heavier weight in the Advanced Airbag System. The heavier weight registered can make the system work as

though an adult were on the seat and deploy the Advanced Airbag when it must be suppressed causing serious or even fatal injury to the child.

- Make sure that the **PASSENGER AIR BAG OFF** light comes on and stays on all the time whenever the ignition is switched on.
- If the **PASSENGER AIR BAG OFF** light does not come on and stay on, immediately install the rear-facing child safety seat in a rear seating position and have the airbag system inspected by your Audi dealer.

Activating the convertible locking retractor

Use the convertible locking retractor to secure a child restraint.

Always heed the child safety seat manufacturer's instructions when installing a child restraint in your vehicle. To activate the convertible locking retractor:

- ▶ Place the child restraint on a seat, preferably on the rear seat.
- ▶ Slowly pull the belt **all the way out**.
- ▶ Route it around or through the child restraint belt path ⇒ .
- ▶ Push the child safety seat down with your full weight to get the safety belt really tight.
- ▶ Insert the belt tongue into the buckle for that seating position.
- ▶ Guide the safety belt back into the retractor until the belt lies flat and snug on the child safety seat.
- ▶ You should hear a “clicking” noise as the belt winds back into the inertia reel. Test the convertible locking retractor by pulling on the belt. You should no longer be able to pull the belt out of the retractor. The convertible locking retractor is now activated.
- ▶ Make sure that the red release button is facing away from the child restraint so that it can be unbuckled quickly.
- ▶ Pull on the belt to make sure the safety belt is properly tight and fastened so that the

seat cannot move forward or sideways more than one inch (2.5 cm).

WARNING

Using the wrong child restraint or an improperly installed child restraint can cause serious personal injury or death in a crash.

- Always make sure that the safety belt retractor is locked when installing a child safety seat. An unlocked safety belt retractor cannot hold the child safety seat in place during normal driving or in a crash.
- Always buckle the child safety seat firmly in place even if a child is not sitting in it. A loose child safety seat can fly around during a sudden stop or in a crash.
- Always make sure the seat backrest to which the child restraint is installed is in an upright position and securely latched into place and cannot fold forward. Otherwise, the seatback with the child safety seat attached to it could fly forward in the event of an accident or other emergency situation.
- Always read and heed all WARNINGS whenever using a child restrained in a vehicle is being used ⇒ *page 177*. Special precautions apply when installing a child safety seat on the front passenger seat ⇒ *page 155, Child restraints on the front seat – some important things to know*.

Deactivating the convertible locking retractor

The convertible locking retractor for child restraints will be deactivated automatically when the belt is wound all the way back into the retractor.

- ▶ Press the red button on the safety belt buckle. The belt tongue will pop out of the buckle.
- ▶ Guide the safety belt all the way back into its stowed position.

Always let the safety belt retract completely into its stowed position. The safety belt can

now be used as an ordinary safety belt without the convertible locking retractor for child restraints.

If the convertible locking retractor should be activated inadvertently, the safety belt must be unfastened and guided completely back into its stowed position to deactivate this feature. If the convertible locking retractor is not deactivated, the safety belt will gradually become tighter and uncomfortable to wear.

WARNING

Improperly installed child safety seats increase the risk of serious personal injury and death in a collision.

- Never unfasten the safety belt to deactivate the convertible locking retractor for child restraints while the vehicle is moving. You would not be restrained and could be seriously injured in an accident.
- Always read and heed all WARNINGS whenever using a child restrained in a vehicle is being used ⇒ *page 177*. Special precautions apply when installing a child safety seat on the front passenger seat ⇒ *page 155, Child restraints on the front seat – some important things to know*.

LATCH Lower anchorages and tethers for children

Child Restraint System anchors and how are they related to child safety

To provide a simpler and more practicable way to attach the child restraint on the vehicle seat, Federal regulations require special lower anchorages in vehicles and devices on new child restraints to attach to the vehicle anchorages.

The combination of the tether anchorages and the lower anchorages is now generally called the **LATCH** system for “**L**ower **A**nchorages and **T**ethers for **C**hildren.”

Forward-facing child restraints manufactured after September 1, 1999, are required by U.S.

federal regulations to comply with new child head movement performance requirements. These new performance requirements make a tether necessary on most new child seats.

Installing a child restraint that requires a top tether without one can seriously impair the performance of the child restraint and its ability to protect the child in a collision. Installing a child restraint that requires a top tether without the top tether may be a violation of state law.

Child restraint manufacturers offer LATCH lower anchorages on their child seats with hook-on or push-on connectors attached to adjustable straps.

In addition to the LATCH lower anchorages, these child restraint systems usually require the use of tether straps to help keep the child restraint firmly in place.

WARNING

Improper installation of child restraints will increase the risk of injury and death in a crash.

- Always follow the instructions provided by the manufacturer of the child restraint you intend to install in your vehicle.
- Never install a child restraint without a properly attached top tether strap if the child restraint manufacturer’s instructions require the top tether strap to be used.
- Improper use of child restraint LATCH lower anchorage points can lead to injury in a collision. The LATCH lower anchorage points are designed to withstand only those loads imposed by correctly fitted child restraints.
- Never mount two child restraint systems on one LATCH lower anchorage point.
- Never secure or attach any luggage or other item to the LATCH lower anchorages.

i Tips

- In Canada, the terms “top tether” with “lower universal anchorages” (or “lower universal anchorage bars”) are used to describe the system.
- In other countries, the term “ISOFIX” is used to describe the lower anchorages.

Location

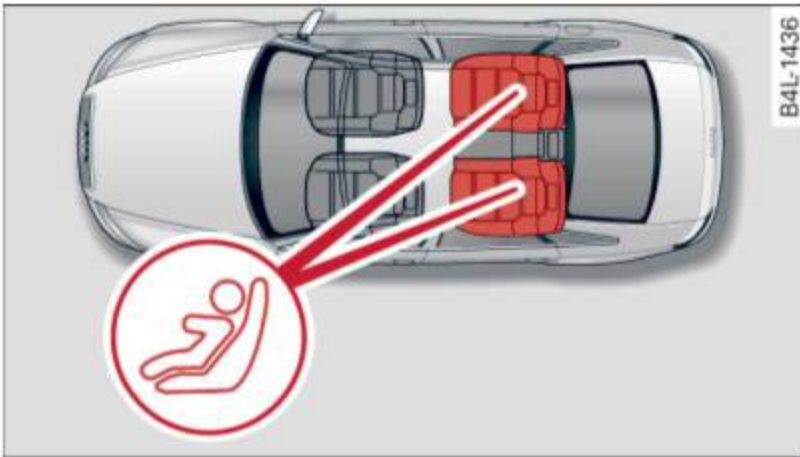

Fig. 180 Schematic overview: LATCH anchorage point locations

The illustration shows the seating locations in your vehicle which are equipped with the lower anchorages system.

Description

The lower anchorage positions are marked for quick locating.



Fig. 181 Rear seatbacks: locator buttons for lower anchorages

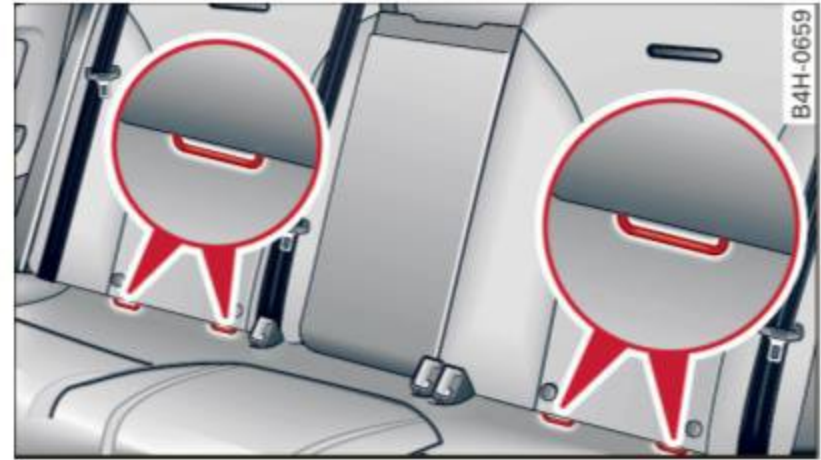

Fig. 182 Rear seats: lower anchorage bracket locations

Attachment locator markers for lower anchorages

Circular locator buttons on the rear seatback indicate the lower anchorage locations on the rear seating positions ⇒ *fig. 181*.

Lower anchorages

The lower anchorage attachment points are located between the rear seatback and rear seat cushion ⇒ *fig. 182*.

Lower anchorages secure the child restraint in the seat without using the vehicle's safety belts. Anchorages provide a secure and easy-to-use attachment and minimize the possibility of improper child restraint installation.

All child restraints manufactured after September 1, 2002, must have lower anchorage attachments for the LATCH system.

Remember that the lower anchorage points are only intended for installation and attachment of child restraints specifically certified for use with LATCH lower anchorages. Child restraints that are not equipped with the lower anchorage attachments can still be installed in compliance with the child restraint manufacturer's instructions on using vehicle safety belts.

⚠ WARNING

Improper use of LATCH lower anchorages can cause serious personal injury in an accident.

- Always carefully follow the child restraints manufacturer's instructions for proper installation of the child restraint

and proper use of the lower anchorages or safety belts in your vehicle.

- Never secure or attach any luggage or other items to the *LATCH* lower anchorages.
- Always read and heed the important information about child restraints in this chapter and WARNINGS ⇒ page 177, *Child Safety*.

Guidance fixtures for lower anchorages

Special guidance fixtures increase the convenience of the lower anchorages and are available from your authorized Audi dealer.



Fig. 183 Outer rear seats: installing the guidance fixtures

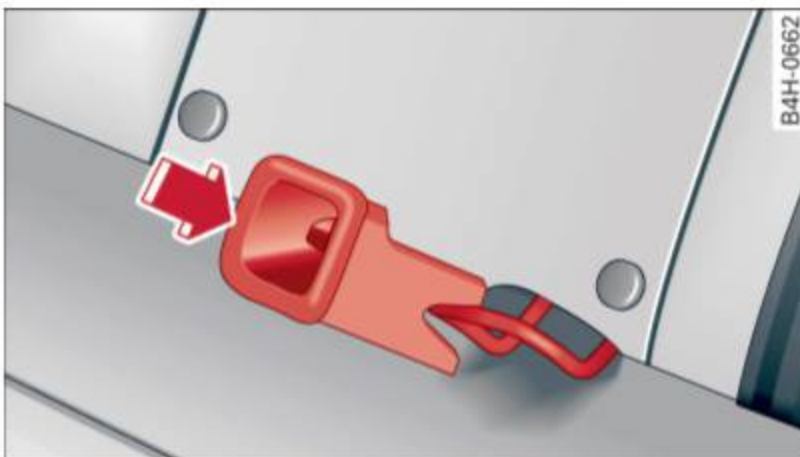

Fig. 184 Close-up: fitting the guidance fixture over the lower anchorage bracket

The lower anchorage attachment points are located on the rear seats between the seat-back and the seat cushion. Special guidance fixtures increase the convenience of the lower anchorages and help protect the seat material from possible damage when installing child restraints.

Installing the guidance fixtures

- ▶ Push down on the seat cushion so that the lower anchorages are visible.

- ▶ Hold the guidance fixture with the part number facing downward and push it in the direction of the arrow onto the anchorage ⇒ fig. 184.
- ▶ Make sure that each of the two guidance fixtures per seat snaps into place.

Removing the guidance fixtures

- ▶ Remove the child restraint according to the child restraint manufacturer's instructions.
- ▶ Push down on the seat cushion so that the lower anchorages are visible.
- ▶ Pull off the guidance fixtures from the lower anchorages.
- ▶ Always remove the guidance fixtures and keep them in a safe place when not in use.

You may find it easier to install child restraints equipped with hooks attached to straps without the guidance fixtures in place. If this is the case, remove the guidance fixtures by pulling them off the anchorages. However, the guidance fixtures can help you to locate the *LATCH* anchorages.

WARNING

Improper use of tether anchorages or lower anchorages can cause serious personal injury in a crash.

- Always carefully follow the child restraint manufacturer's instructions for proper installation and use of child restraint systems.
- Never use the *LATCH* or tether anchorages to attach safety belts or other kinds of occupant restraints.
- Child restraint tether attachments and lower attachments are only designed to secure a child restraint that has been equipped to use these anchorages.
- Tether anchorages and lower anchorages are designed to withstand only those loads imposed by correctly fitted child restraints. Under no circumstances can they be used safely for adult or child safety belts or harnesses.

- Never mount more than one child restraint to a single tether or to a lower anchorage point. Attaching two child restraints to a single anchorage point can cause the anchorage to fail and cause serious personal injury in a crash.

! Note

- Remove the guidance fixtures before folding the rear seatback to prevent damaging the seat cushion.
- To attach the child restraint securely, the seat must be moved to the farthest rear position, the seat height set to the lowest position and the head restraint must be adjusted to the vertical position ⇒ *page 61*.
- If you leave the guidance fixtures installed for several days, they could leave a mark on the upholstery on the seat cushion and backrest in the area that the guidance fixtures were installed. The upholstery would also be permanently stretched around the guidance fixtures. This applies especially to leather seats.

Installing a child restraint with LATCH lower anchorages

Whenever you install a child restraint always follow the child restraint manufacturer's instructions.

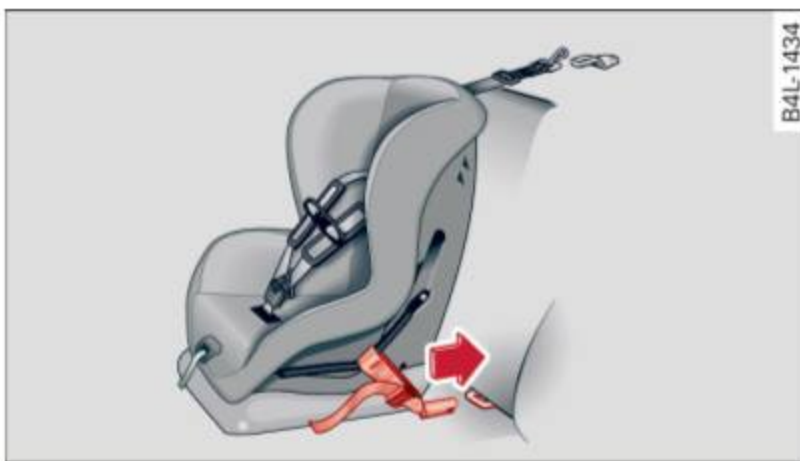

Fig. 185 Lower anchorages: proper mounting

Mounting

- ▶ Make sure the seatback of the rear seat bench is in the upright position and securely latched in place.

- ▶ Attach both hook-on connectors with the spring catch release on the child safety seat onto the LATCH lower anchorage so that the connectors lock into place ⇒ *fig. 185*.
- ▶ Pull on the connector attachments to make sure they are properly attached to the LATCH lower anchorage.
- ▶ Pull straps tight following the child restraint manufacturer's instructions.

Releasing

- ▶ Loosen the tension on the straps following the child restraint manufacturer's instructions.
- ▶ Depress the spring catches to release the anchorage hooks from the lower anchorages.

Remember: Use tether straps to help keep the child restraint firmly in place.

! WARNING

Improper use of the LATCH system can increase the risk of serious personal injury and death in an accident.

- These anchors were developed only for child safety seats using the "LATCH" system.
- Never attach other child safety seats, belts or other objects to these anchors.
- Always make sure that you hear a click when latching the seat in place. If you do not hear a click the seat is not secure and could fly forward and hit the interior of the vehicle, or be ejected from the vehicle.

! WARNING

Improper installation of child restraints will increase the risk of injury in an accident.

- Always follow the child restraint system manufacturer's instructions for proper installation of the child restraint system and proper use of tether straps as well as the lower anchorages or safety belts in your vehicle.

- Always read and heed the important information and WARNINGS about child safety and the installation of child restraint systems ⇒ *page 177, Child Safety*.

! Note

On vehicles with power adjustable rear seats* some criteria must be observed when attaching the child restraint using the **LATCH** system:

- To attach the child restraint securely, the seat must be moved to the farthest rear position, the seat height set to the lowest position and the head restraint must be adjusted to the vertical position ⇒ *page 61*.
- If a child safety seat is attached to one of the rear seats, this seat must not be adjusted using the power controls under any circumstances. The **Entry assistance** for this seat must also be deactivated in the MMI ⇒ *page 64*. The child safety seat as well as the rear seat can be damaged by the adjustment process.

Tether anchors and tether straps

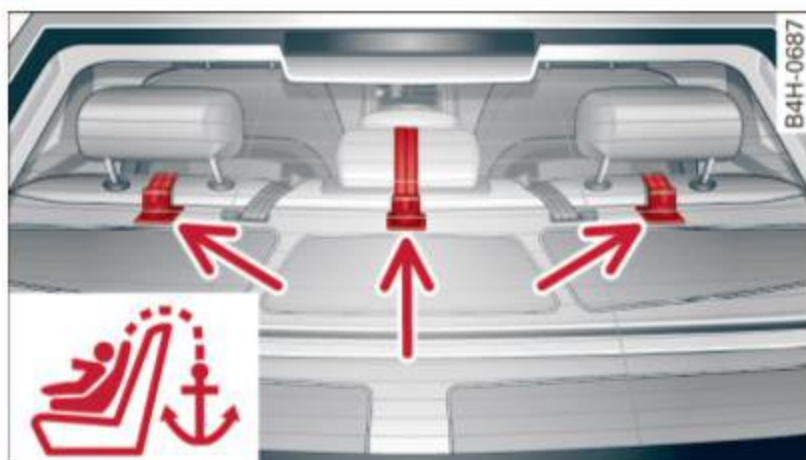

Fig. 186 Tether anchors: recess flaps behind the rear seatbacks

The tether anchors for the two*/three rear seating positions are located in recesses in the rear window shelf ⇒ *fig. 186*. Vehicles with two rear seating positions* are equipped with two tether anchors.

A tether is a straight or V-shaped strap that attaches the top part of a child restraint to special anchorage points in the vehicle.

The purpose of the tether is to reduce the forward movement of the child restraint in a crash, in order to help reduce the risk of head injury that could be caused by striking the vehicle interior.

Forward facing child restraints manufactured after September 1, 1999, are required by U.S. federal regulations to comply with new child head movement performance requirements. These new performance requirements make a tether necessary on most new child safety seats.

! WARNING

Improper installation of child restraints will increase the risk of injury and death in a crash.

- Always follow the instructions provided by the manufacturer of the child restraint you intend to install in your Audi.
- Improper use of child restraint anchors (including tether anchors) can lead to injury in a collision. The anchors are designed to withstand only those loads imposed by correctly fitted child restraints.
- Never mount two child restraint systems on one LATCH lower anchor point.
- Never attach two child restraint systems to one tether strap or tether anchorage.
- Never attach a tether strap to a tie-down hook in the luggage compartment.
- Never use child restraint tether anchorages to secure safety belts or other kinds of occupant restraints.
- Never secure or attach any luggage or other items to the LATCH lower anchorages or to the tether anchors.
- If a tether or other strap is used to attach a child restraint to the front passenger seat, make sure that it is not so tight, that it causes the weight-sensing mat to measure more weight than is actually on the seat.
- The heavier weight registered can make the Advanced Airbag System work as though an adult were on the seat and deploy the Advanced Airbag when it must

be suppressed causing serious or even fatal injury to the child.

- If you must install a rearward facing child safety seat on the front passenger seat because of exceptional circumstances and the **PASSENGER AIR BAG OFF** light does not come on and stay on, immediately install the rear-facing child safety seat in a rear seating position and have the airbag system inspected by your Audi dealer.

Installing the upper tether strap on the anchorage

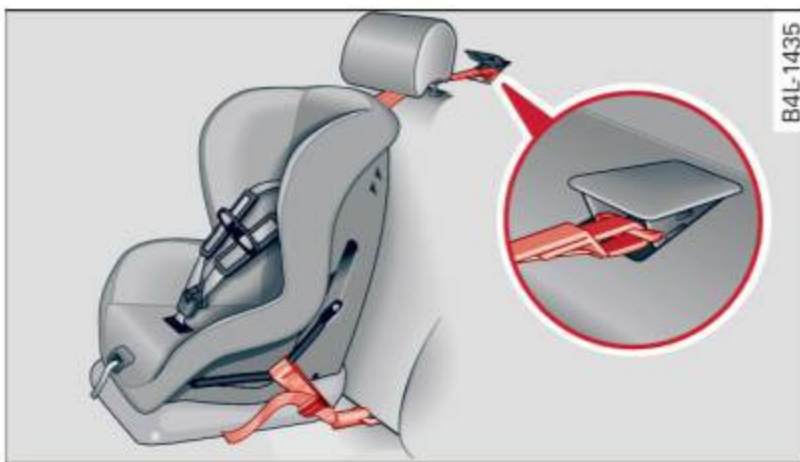

Fig. 187 Tether strap: proper routing and mounting

Installing the tether strap

- ▶ Release or deploy the tether strap on the child restraint according to the child restraint manufacturer's instructions.
- ▶ Guide the upper tether strap **under** the rear head restraint ⇒ *fig. 187* (raise the head restraint if necessary).
- ▶ Center seating position*: Guide the upper tether strap over the rear head restraint.
- ▶ Tilt the recess flap up to expose the anchor bracket.
- ▶ Attach the tether strap anchorage hook into the opening of the tether anchorage.
- ▶ Pull on the tether strap hook so that the spring catch of the hook engages.
- ▶ Tighten the tether strap firmly following the child restraint manufacturer's instructions.

Releasing the tether strap

- ▶ Loosen the tension following the child restraint manufacturer's instructions.
- ▶ Depress the spring catch on the hook and release it from the anchorage.

! Note

If you leave the child restraint with the tether strap firmly installed for several days, this could leave a mark on the upholstery on the seat cushion and backrest in the area where the tether strap was installed. The upholstery would also be permanently stretched around the tether strap. This applies especially to leather seats.

Using tether straps on rearward-facing child restraints

Currently, few rear-facing child restraint systems come with a tether. Please read and heed the child restraint system manufacturer's instructions carefully to determine how to properly install the tether.

! WARNING

A child in a rearward-facing child safety seat installed on the front passenger seat will be seriously injured and can be killed if the front airbag inflates - even with an Advanced Airbag System.

- The inflating airbag will hit the child safety seat or infant carrier with great force and will smash the child safety seat and child against the backrest, center armrest, or door.
- A tight tether or other strap on a rearward-facing child restraint attached to the front passenger seat can put too much pressure on the weight-mat in the seat and register a heavier weight in the Advanced Airbag System. The heavier weight registered can make the system work as though an adult were on the seat and deploy the Advanced Airbag when it must be suppressed causing serious or even fatal injury to the child.
- If you must install a rearward facing child safety seat on the front passenger seat because of exceptional circumstances and the **PASSENGER AIR BAG OFF**

light does not come on and stay on, immediately install the rear-facing child safety seat in a rear seating position and have the airbag system inspected by your Audi dealer.

Additional Information

Sources of information about child restraints and their use

There are a number of sources of additional information about child restraint selection, installation and use:

NHTSA advises that the best child safety seat is the one that fits your child and fits in your vehicle, and that you will use correctly and consistently.

Try before you buy!

U.S National Highway Traffic Safety Administration

Tel.: 1-888-327-4236 (TTY: 1-800-424-9153)
www.nhtsa.gov

National SAFE KIDS Campaign

Tel.: (202) 662-0600
www.safekids.org

Safety BeltSafe U.S.A

Tel.: (800) 745-SAFE (English)
Tel.: (800) 747-SANO (Spanish)
www.carseat.org

Transport Canada Information Centre

Tel.: 1-800-333-0371 or call
1-613-998-8616 if you are in the Ottawa area
<http://www.tc.gc.ca/eng/roadsafety/menu.htm>

Audi Customer Relations

Tel.: (800) 822-2834

Audi pre sense

Preventative passenger protection

Applies to vehicles: with Audi pre sense

Audi pre sense can initiate steps to help protect vehicle occupants in certain situations. The functions described depend on equipment installed in your vehicle:

Audi pre sense basic

The following functions can be triggered in certain driving situations:

- Tightening of the safety belts (for example, during heavy braking): the front safety belts have reversible belt pretensioners. If a collision does not occur, the safety belts loosen slightly and are ready to be tightened again.
- Closing the windows and the sunroof*: the windows and the sunroof* close leaving a small open gap.

Audi pre sense basic functions can be triggered at speeds above 20 mph (30 km/h).

Vehicles with Audi drive select*: the deployment time is adapted in dynamic mode.

Audi pre sense front (vehicles with adaptive cruise control*)

Audi pre sense front includes the functions in Audi pre sense basic. In addition, within the limits of the system, the likelihood of a collision with the vehicle immediately ahead is also calculated. If the system senses an imminent collision the following functions can be triggered:

- Braking guard ⇒ *page 100*
- Tightening the safety belts
- Closing the windows and the sunroof* (leaving a small open gap)

Audi pre sense rear (vehicles with Audi side assist*)

Audi pre sense rear includes the functions in Audi pre sense basic. In addition, the likelihood of a rear-end collision with the vehicle coming from behind is also calculated. If the

risk of a collision is detected, the following functions can be triggered:

- Tightening the safety belts
- Closing the windows and the sunroof* (leaving a small open gap)
- Adjusting the seats: the settings for the power head restraints, the upper sections of the backrests and the pneumatic side bolsters* are optimized for the front seats and the outboard rear seats*. If a collision does not occur, the previous seat settings are restored.

Audi pre sense plus

Audi pre sense plus includes the functions in Audi pre sense front and Audi pre sense rear.

Error message

Audi pre sense: not available

Preventative passenger protection is not available. See your authorized Audi dealer immediately to have the malfunction corrected.

WARNING

Audi pre sense cannot overcome the laws of physics. It cannot prevent a collision. Do not let the increased safety provided tempt you to take risks. This will increase the risk of a collision and serious personal injuries.

- The sensors cannot always detect all objects. This increases the risk of a collision.
- Audi pre sense does not detect people or animals or objects that are crossing the vehicle's path ⇒ *page 94*.
- The radar sensor's vision can be reduced by heavy rain, ice, snow, heavy road spray and reflections from guard rails, tunnel entrances, etc. These and similar conditions can prevent vehicles from being accurately detected and in some cases they may not be detected at all.

! Note

The sensors can be displaced by impacts or damage to the bumper, wheel housing and underbody. This can affect the function of the Audi pre sense system. Have your authorized Audi dealer check to make sure that the system is working properly.

i Tips

- Certain Audi pre sense functions are not available when ASR is switched off (sport mode) or when driving in reverse.
- The Audi pre sense functions may not be available if there is a malfunction in the ESC system or the airbag control module.
- The Audi pre sense front/plus functions are not available if there is a malfunction in the adaptive cruise control* system
⇒ *page 101*.
- The Audi pre sense rear/plus functions are not available if there is a malfunction in the Audi side assist* system
⇒ *page 101*.

Intelligent technology

Notice about data recorded by vehicle control modules

Your vehicle is not equipped with an Event Data Recorder (EDR), installed by some manufacturers for the express purpose of capturing data for retrieval after an accident or crash event. EDR's are sometimes called "crash recorders".

Some state laws restrict the retrieval or downloading of data stored by EDR's that were installed in a vehicle for the express purpose of retrieving data after an accident or crash event without the owner's consent.

Although your vehicle is not equipped with an EDR, it is equipped with a number of electronic control modules for various vehicle systems such as, for example, engine function, emission control, as well as for the airbags and safety belts.

These electronic control modules also record vehicle-related data during normal vehicle operation for diagnostic and repair purposes. The recording capacity of the electronic control modules is limited to data (no sound is recorded) and only a small amount of data is actually recorded over a very limited period of time and stored when a system fault or other condition is sensed by a control unit. Some of the data then stored may relate to vehicle speed, direction, braking as well as restraint system use and performance in the event of a crash or other condition. Stored data can only be read and downloaded with special equipment.

Electronic Stabilization Control (ESC)

Description

ESC helps to improve road holding and vehicle dynamics to help reduce the probability of skidding and loss of vehicle control. It works only when the engine is running. ESC detects

certain difficult driving situations, including when the vehicle is beginning to spin (yaw) out of control and helps you to get the vehicle back under control by selectively braking the wheels, and/or reducing engine power and providing steering assistance to help hold the vehicle on the driver's intended course. The indicator light  in the instrument cluster blinks when ESC is taking action to help you control the vehicle.

ESC has limitations. It is important to remember that ESC cannot overcome the laws of physics. It will not always be able to help out under all conditions you may come up against. For example, ESC may not always be able to help you master situations where there is a sudden change in the coefficient of friction of the road surface. When there is a section of dry road that is suddenly covered with water, slush or snow, ESC cannot perform the same way it would on the dry surface. If the vehicle hydroplanes (rides on a cushion of water instead of the road surface), ESC will not be able to help you steer the vehicle because contact with the pavement has been interrupted and the vehicle cannot be braked or steered. During fast cornering, particularly on winding roads, ESC cannot always deal as effectively with difficult driving situations than at lower speeds. When towing a trailer, ESC is not able to help you regain control as it would if you were not towing a trailer.

Always adjust your speed and driving style to road, traffic and weather conditions. ESC cannot override the vehicle's physical limits, increase the available traction, or keep a vehicle on the road if road departure is a result of driver inattention. Instead, ESC improves the possibility of keeping the vehicle under control and on the road during extreme maneuvers by using the driver's steering inputs to help keep the vehicle going in the intended direction. If you are traveling at a speed that causes you to run off the road before ESC can provide any assistance, you may not experience the benefits of ESC. ►

ESC includes and/or works together with the anti-lock braking system (ABS), brake assist system, anti-slip regulation (ASR), electronic differential lock (EDL), dynamic steering* and electronic interaxle differential lock*. ESC is switched on all the time. In certain situations when you need less traction, you can switch off ASR by pressing the button above ⇒ *page 201, fig. 188* the selector lever. Be sure to switch ASR on again when you no longer need less traction.

Anti-lock braking system (ABS)

ABS prevents the wheels from locking up when braking. The vehicle can still be steered even during hard braking. Apply steady pressure to the brake pedal. Do not pump the pedal. A pulsing in the brake pedal indicates that the system is helping you to brake the vehicle.

Brake assist system

The brake assist system can decrease braking distance. It increases braking power when the driver presses the brake pedal quickly in emergency situations. You must press and hold the brake pedal until the situation is over. In vehicles with adaptive cruise control*, the brake assist system is more sensitive if the distance detected to the vehicle ahead is too small.

Anti-slip regulation (ASR)

ASR reduces engine power when the drive wheels begin to spin and adapts the force to the road conditions. This makes it easier to start, accelerate and drive up hills.

Electronic differential lock (EDL)

The EDL brakes wheels that are spinning and transfers the drive power to the other drive wheel or wheels if the vehicle is equipped with all wheel drive*. This function is available up to about 75 mph (120 km/h).

In extreme cases, EDL automatically switches off to help keep the brake on the braked wheel from overheating. EDL will switch on again automatically when conditions have returned to normal.

Dynamic steering*

On vehicles with dynamic steering, ESC helps stabilize the steering in certain situations.

Electronic interaxle differential lock function*



The electronic interaxle differential lock function activates when driving through curves. Braking is targeted toward the wheels on the inside of the curve as needed. This helps to minimize front wheel skid, improves traction and allows for more precise driving through curves.

WARNING

- ESC, ABS, ASR, EDL, dynamic steering* and the electronic interaxle differential lock function* cannot overcome the laws of physics. This is especially important on slippery or wet roads. If the systems begin acting to stabilize your vehicle, you should immediately change your speed to match the road and traffic conditions. Do not let the increased safety provided by these systems tempt you to take risks. Doing so will increase the risk of a loss of vehicle control, collision and serious personal injuries.
- Always adapt your speed to road, traffic and weather conditions. The risk of losing control of the vehicle increases when driving too fast, especially through curves and on slippery or wet roads, and when driving too close to vehicles up ahead. ESC, ABS, the brake assist system, EDL, ASR, dynamic steering* and the electronic interaxle differential lock function* cannot prevent collisions.
- Always accelerate with special care on even, smooth surfaces such as those that are wet or covered with ice and snow. The drive wheels can spin even with these assistance systems that cannot always help to reduce the risk of loss of vehicle control.

i Tips

- ABS and ASR only work correctly when all four wheels are equipped with identical tires. Different tire sizes can lead to a reduction in engine power.
- You may hear noises when the systems described are working.

- If the indicator light  or **ABS** (USA models)/ (Canada models) appears, there may be a malfunction ⇒ *page 19*, ⇒ *page 18*.

Switching on and off

ESC turns on automatically when you start the engine.

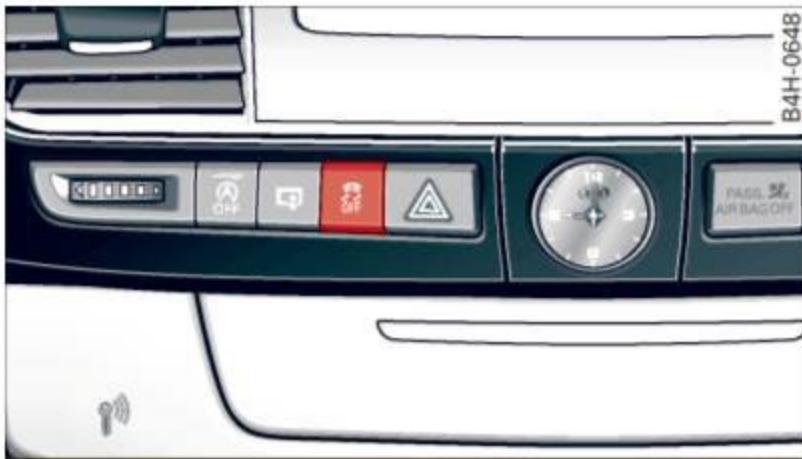

Fig. 188 Center console with ESC OFF button

The following situations are exceptions where it may be useful to switch on sport mode to allow the wheels to spin:

- Rocking the vehicle to free it when it is stuck
- Driving in deep snow or on loose ground
- Driving with snow chains

ESC levels

	Sport mode on	Sport mode off
Behavior	The ESC and ASR stabilization functions are limited ⇒  .	The full stabilization function of the ESC and ASR is available again.
Operation	Press the  button.	Press the  button again.
Indicator lights	 turns on.	 turns off.
Driver messages	Stabilization control (ESC): Sport Warning! Reduced stability	Stabilization control (ESC): On

! WARNING

- You should only switch sport mode on if your driving abilities and road conditions permit.
- The stabilization function is limited when sport mode is switched on. The driving wheels could spin and the vehicle could swerve, especially on slick or slippery road surfaces.

i Tips

Sport mode cannot be switched on when adaptive cruise control* is switched on.

Braking

General information

What affects braking efficiency?

Operating conditions and driving habits

The brakes on today’s automobiles are still subject to wear, depending largely on operating conditions and driving habits ⇒ . On vehicles that are either driven mostly in stop-and-go city traffic or are driven hard, the brake pads should be checked by your authorized Audi dealer more often than specified in the **Warranty & Maintenance booklet**. Failure ▶

to have your brake pads inspected can result in reduced brake performance.

On steep slopes, you should use the braking effect of the engine. This way, you prevent unnecessary wear on the brake system. If you must use your brakes, do not hold the brakes down continuously. Pump the brakes at intervals.

Operating noise

Noises may occur when braking depending on the speed, braking force and outside conditions such as temperature and humidity.

Effect of water and road salt

In certain situations, for example after driving through water, in heavy rain, after overnight condensation or after washing your car, the braking effect can be reduced by moisture or ice on the brake rotors and brake pads. The brakes must be dried first with a few careful brake applications.

At higher speeds and with the windshield wipers turned on, the brake pads press against the brake rotors for a short amount of time. This occurs at regular intervals without the driver noticing and provides for better brake response time under wet conditions.

The effectiveness of the brakes can be reduced when the vehicle is driven on a salt-covered road and the brakes are not used. Likewise, you clean off accumulated salt coating from brake discs and pads with a few cautious applications of the brake ⇒ ⚠.

Corrosion

There may be a tendency for dirt to build up on the brake pads and corrosion to form on the discs if the car is not driven regularly or only for short trips with little use of the brakes.

If the brakes are not used frequently, or if corrosion has formed on the discs, it is advisable to clean off the pads and discs by braking firmly a few times from a moderately high speed ⇒ ⚠.

Faults in the brake system

If you should notice a *sudden* increase in brake pedal travel, then one of the two brake circuits may have failed ⇒ ⚠.

Low brake fluid level

Malfunctions can occur in the brake system if the brake fluid level is too low. The brake fluid level is monitored electronically.

Brake lining wear status

Brake lining wear may be checked by visual inspection of the condition of the brake pads through the openings in the wheel. If necessary, the wheel may be removed for this inspection ⇒ *page 272, Changing a wheel.*

WARNING

- You should perform braking maneuvers for the purpose of cleaning the brake system only if road conditions permit. Other road users must not be put at risk - you may cause an accident!
- Before descending a steep grade, reduce speed and shift transmission into a lower gear or lower driving range. Do not ride the brakes or hold the pedal down too long or too often. This could cause the brakes to get hot and diminish braking efficiency.
- Do not “ride the brakes” by resting your foot on the pedal when you do not intend to brake. This may cause the brakes to overheat, premature wear and increased stopping distance.
- Under certain climatic and operating conditions such as passing through water, driving in heavy rain or after washing the vehicle, the effectiveness of the brakes can be reduced. In winter, ice can accumulate on the brake pads, linings, discs and drums. Carefully apply brakes for a test. Brakes will dry and ice coatings will be cleaned off after a few careful brake applications.
- Driving for an extended period of time on salt-covered roads without using your brakes can also affect braking efficiency.

Clean off accumulated salt coating from brake discs and pads with a few careful brake applications.

- If you damage the front spoiler, or if you install a different spoiler, be sure the air flow to the front brakes is not obstructed. Otherwise the brake system could overheat reducing the effectiveness of the entire brake system.
- Failure of one brake circuit will impair the braking capability resulting in an increased stopping distance. Avoid driving the vehicle and have it towed to the nearest Audi dealer or qualified workshop.
- Never let the vehicle roll to a stop with the engine shut off.
- If the brake booster is not working, the brake pedal must be pressed considerably harder to make up for the lack of booster assistance.

Brake booster

The brake booster adds extra braking power.

The brake booster works with vacuum pressure which is created only when the engine is running ⇒ .

WARNING

- Never let the vehicle roll to a stop with the engine shut off.
- If the brake booster is not working, for example when towing your vehicle, or because the brake booster has somehow been damaged, the brake pedal must be pressed considerably harder to make up for the lack of booster assistance.

Servotronic - advanced power steering system

The power steering systems use the power of the running engine to allow precise steering with little effort.

The advanced *Servotronic* power steering system senses the road speed and electronically adjusts power assistance to provide comforta-

ble and safe steering response exactly matched to the vehicle speed.

Power steering will not work if the engine is off. As a result, the steering wheel will be hard to turn.

The power steering fluid level is checked during the scheduled maintenance services.

Note

If there is an electronic malfunction, *servotronic* will still function like a conventional power steering system, providing a constant steering support force that is no longer proportionate to the vehicle speed. This is most noticeable when turning the steering wheel at low speeds (for example when parking), - more effort will be required than usual.

- Be aware of the different than usual steering response and adjust your steering force accordingly.
- Have the problem checked and set right by an Audi dealer as soon as possible.

Tips

- When the engine is running, never hold the steering wheel turned all the way to the right or to the left for longer than 15 seconds. The power steering pump will overheat the hydraulic fluid if you keep holding the steering wheel turned all the way. This is likely to damage the power steering system.
- If the power steering system should fail entirely, or if the engine is not running (for example, while being towed), you will still be able to steer the vehicle. However, *considerably* more effort will be required to do so.
- If the power steering system should have a leak, or is not functioning properly, contact your authorized Audi dealer immediately.
- The power steering system requires a specially formulated hydraulic fluid. The power steering fluid reservoir is located in the engine compartment ⇒ *page 233*.

The correct fluid level in the reservoir is important for proper functioning of the power steering.

Driving with your quattro

With All Wheel Drive, all four wheels are driven.

General information

With All Wheel Drive, power is distributed to all four wheels. This happens automatically depending on your driving style and the road conditions at the time. See also ⇒ *page 199*. With the sport differential*, power distribution to the rear wheels is variable and can be adjusted with Audi drive select* ⇒ *page 110*. Always read and follow safety precautions ⇒ .

Winter tires

When driving in the winter, your vehicle with All Wheel Drive has an advantage, even with regular tires. In winter road conditions it may be advisable to mount winter tires (or all-season tires) for improved driveability and braking: these tires must be mounted on **all four wheels**. See also ⇒ *page 263, Winter tires*.

Snow chains

Where snow chains are mandatory on certain roads, this normally also applies to vehicles with All Wheel Drive ⇒ *page 264, Snow chains*.

Replacing wheels/tires

Vehicles with All Wheel Drive must always have tires of the same size. Also avoid tires with different tread depths. For details see *page 259, New tires and replacing tires and wheels*.

Off-Road driving?

Your Audi does not have enough ground clearance to be used as an off-road vehicle. It is therefore best to avoid rough tracks and uneven terrain as much as possible. Also refer to ⇒ *page 209*.

WARNING

Always adjust your driving to road and traffic conditions. Do not let the extra safety afforded by All Wheel Drive tempt you into taking extra risks.

- Although the All Wheel Drive is very effective, always remember that braking capacity is limited by tire traction. You should therefore not drive at excessive speeds on icy or slippery road surfaces.
- On wet road surfaces, be careful not to drive too fast because the front wheels could begin to slide on top of the water (aquaplaning). If this should occur, you will have no warning from a sudden increase in engine speed as with a front-wheel drive vehicle. Always drive at speeds which are suited to the road conditions – risk of crash.

Energy management

Starting ability is optimized

Energy management controls the distribution of electrical energy and thus optimizes the availability of electrical energy for starting the engine.

If a vehicle with a conventional energy system is not driven for a long period of time, the battery is discharged by idling current consumers (e.g. immobilizer). In certain circumstances it can result in there being insufficient energy available to start the engine.

Intelligent energy management in your vehicle handles the distribution of electrical energy. Starting ability is markedly improved and the life of the battery is extended.

Basically, energy management consists of **battery diagnosis, idling current management** and **dynamic energy management**.

Battery diagnosis

Battery diagnosis continuously determines the state of the battery. Sensors determine battery voltage, battery current and battery

temperature. This determines the current state of charge and the power of the battery.

Idling current management



Idling current management reduces energy consumption while the vehicle is standing. With the ignition switched off, it controls the energy supply to the various electrical components. Data from battery diagnosis is considered.

Depending on the battery's state of charge, individual consumers are gradually turned off to prevent excessive discharge of the battery and thus maintain starting capability.

Dynamic energy management

While the vehicle is being driven, dynamic energy management distributes the energy generated according to the needs of the individual components. It regulates consumption, so that more electrical energy is not being used than is being generated and ensures an optimal state of charge for the battery.

Tips

- But even energy management cannot negate the limits of physics. Consider that the power and life of a battery are limited.
- If starting ability is threatened, the indicator light  appears ⇒ *page 16*,  *Battery*.

What you should know

The highest priority is given to maintaining starting capability.

The battery is severely taxed in short-distance driving, in city traffic and during the cold time of year. Abundant electrical energy is required, but only a little is generated. It is also critical if the engine is not running and electrical components are turned on. In this instance energy is being consumed but none is being generated.

It is in precisely these situations that you will notice energy management actively regulating the distribution of energy.

Vehicle stands for an extended period

If you do not drive your vehicle over a period of several days or weeks, electrical components are gradually cut back or switched off. This reduces energy consumption and maintains starting capability over a longer period. Some of the convenience functions may not operate, such as the interior lights or the power seat adjustment. The convenience functions will be available again when you switch on the ignition and start the engine.

With the engine turned off

If you listen to the radio, for example, with the engine turned off or use other MMI functions, the battery is being discharged.

If starting capability is jeopardized due to energy consumption, the following warning appears in the MMI display:

Please start the engine soon or the system will be turned off.

The warning indicates that the system will be turned off automatically after 3 minutes. If you wish to continue using the functions, you have to start the engine.

With the engine running

Although electrical energy is generated when the vehicle is being driven, the battery can become discharged. This happens mostly when little energy is being generated and a great deal consumed and the battery's state of charge is not optimal.

To bring the energy balance back into equilibrium, consumers which require especially large amounts of energy are temporarily cut back or switched off. Heating systems in particular require a great deal of energy. If you notice, for example, that the heated seats* or the heated rear window are not heating, they have been temporarily cut back or switched

off. These systems will be available again as soon as the energy balance has been restored.

You will also notice that engine idle speed has been increased slightly. This is normal and not a cause for concern. By increasing engine idle speed the additional energy required is generated and the battery is charged.

Driving and environment

The first 1,000 miles (1,500 km) and afterwards

New engine

The engine needs to be run-in during the first 1,000 miles (1,500 km).

For the first 600 miles (1,000 kilometers):

- ▶ Do not use full throttle.
- ▶ Do not drive at engine speeds that are more than 2/3 of the maximum permitted RPM.
- ▶ Avoid high engine speeds.

From 600 to 1,000 miles (1,000 to 1,500 kilometers):

- ▶ Speeds can *gradually* be increased to the maximum permissible road or engine speed.

During and after break-in period

- ▶ Do not rev the engine up to high speeds when it is cold. This applies whether the transmission is in N (Neutral) or in gear.

After the break-in period

- ▶ Do not exceed maximum engine speed under any circumstances.
- ▶ Upshift into the next higher gear *before* reaching the red area at the end of the tachometer scale ⇒ *page 10*.

During the first few hours of driving, the engine's internal friction is higher than later when all the moving parts have been broken in. How well this break-in process is done depends to a considerable extent on the way the vehicle is driven during the first 1,000 miles (1,500 kilometers).

Note

Extremely high engine speeds are automatically reduced. However, these rpm limits are programmed for an engine well run-in, not a new engine.



For the sake of the environment

Do not drive with unnecessarily high engine speeds - upshifting early saves fuel, reduces noise and protects the environment.

New tires

If your vehicle is running on new tires, drive particularly careful for the first 350 miles (500 kilometers) after fitting.



WARNING

New tires tend to be slippery and must also be "broken-in". Be sure to remember this during the first 350 miles (500 kilometers). Brake gently. Avoid following closely behind other vehicles or other situations that might require sudden, hard braking.

New brake pads

Remember that new brake pads do not have a full braking effect during the first 250 miles (400 kilometers) after they are installed.

New brake pads have to be "broken in" before they have optimal grab ⇒ .

During the break-in period, you should avoid putting severe loads on the brakes. Severe loads include, for example, sudden hard braking, in particular at very high speeds or, for example, on mountain passes.



WARNING

New brake pads don't have the best stopping power and must be "broken-in" during the initial 100 to 150 miles (150 to 200 kilometers) of normal city driving. You can compensate for this by pressing the brake pedal more firmly. This also applies later when new pads are installed.

Catalytic converter

Applies to vehicles: with gasoline engine

It is very important that your emission control system (catalytic converter) is functioning properly to ensure that your vehicle is running in an environmentally sound manner.

- ▶ Always use lead-free gasoline ⇒ *page 222, Fuel supply.*
- ▶ Never run the tank down all the way to empty.
- ▶ Never put too much motor oil in your engine ⇒ *page 237, Adding engine oil* .
- ▶ Never try to push- or tow-start your vehicle.

The catalytic converter is an efficient “clean-up” device built into the exhaust system of the vehicle. The catalytic converter burns many of the pollutants in the exhaust gas before they are released into the atmosphere.

The exclusive use of unleaded fuel is critically important for the life of the catalytic converter and proper functioning of the engine.



WARNING

The temperature of the exhaust system is high, both when driving and after stopping the engine.

- Never touch the exhaust tail pipes once they have become hot. This could result in burns.
- Do not park or operate the vehicle in areas where the hot exhaust system may come in contact with dry grass, brush, fuel spill or other material which can cause a fire.
- Do not apply additional undercoating or rustproofing on or near the exhaust manifold, exhaust pipes, catalytic converter or heat shields. During driving, the substance used for undercoating could overheat and cause a fire.



Note

- Be aware that just one tank filling with **leaded** fuel will already seriously degrade the performance of the catalytic converter.

- Do not exceed the correct engine oil level ⇒ *page 237.*
- Do not drive until the fuel tank becomes completely empty. The engine could misfire. Unburned fuel could also get into the exhaust system and this could cause the catalytic converter to overheat.
- Do not switch off the ignition while the vehicle is moving.
- Do not continue to operate your vehicle under these conditions, as otherwise fuel can reach the catalytic converter. This could result in overheating of the converter, requiring its replacement.
- To assure efficient operation of the Emission Control System:
 - Have your vehicle maintained properly and in accordance with the service recommendations in your Warranty & Maintenance booklet.
 - Lack of proper maintenance as well as improper use of the vehicle will impair the function of the emission control system and could lead to damage.



For the sake of the environment

Even when the Emission Control System is operating properly, the exhaust gas can have a sulfur-like exhaust gas smell under some operating states. This depends on the sulfur content of the fuel being used. Using a different brand of fuel may help, or filling the tank with lead-free super grade gasoline.

Diesel particulate filter

Applies to vehicles: with diesel engine

The diesel particulate filter filters nearly all of the soot particles out of the exhaust. The filter cleans itself automatically under normal driving conditions. If the filter cannot clean itself (for example, because you are only driving short distances), the filter becomes clogged with soot and the  symbol for the diesel particulate filter illuminates ⇒ *page 21.* ▶

! WARNING

- Do not park your vehicle over flammable materials such as grass or leaves because the high temperature of the diesel particulate filter could start a fire.
- Do not apply an underbody protectant in the exhaust system area or a fire could start.

Shutting down vehicle

If you would like your vehicle to remain inoperative for a longer period of time, contact an Audi or other specialized dealer. They can advise you on necessary precautions e.g. corrosion prevention, maintenance and storage. Pay attention to additional information concerning the battery. Refer to ⇨ *page 243*.

Avoid damaging the vehicle

When you are driving on poor roads, or over curbs, steep ramps, etc., make certain that low-lying parts such as spoilers and exhaust system parts do not bottom out and get damaged.

This is especially true for vehicles with low-slung chassis (sports chassis)* and fully loaded vehicles.

Driving through water on roads

Note the following to avoid vehicle damage when driving through water, for example on flooded roads:

- The water must not be any higher than the bottom of the vehicle body.
- Do not drive faster than walking speed.

! WARNING

After driving through water, mud, slush, etc., the brakes may be slow to take effect because of wet brake rotors and pads. Dry

the brakes first by braking carefully to restore the full braking effect.

! Note

- Vehicle components such as the engine, transmission, suspension or electrical system can be severely damaged by driving through water.
- Always switch off the Start-Stop-System when driving through water ⇨ *page 88*.

i Tips

- Check the depth of the water before driving through it.
- Do not stop the vehicle, drive in reverse or switch the engine off when driving through water.
- Keep in mind that oncoming vehicles may create waves that raise the water level and make it too deep for your vehicle to drive through safely.
- Avoid driving through salt water because it can cause corrosion.

Operate your vehicle economically and minimize pollution

General

Your personal style of driving will determine the economy of your vehicle, as well as exhaust and noise levels.

Fuel economy, environmental impact, and wear on your engine, brakes and tires largely depend on three factors:

- your personal driving style
- operating conditions
- technical limitations

If you anticipate what you need to do next and drive economically, you can easily cut your fuel consumption by 10-15 percent. This section will give you some tips on how you can help the environment and your pocketbook. ▶

i Tips

The consumption estimates as published by ENVIRONMENTAL PROTECTION AGENCY (EPA) and Transport Canada may not correspond to your actual consumption on the road, which will vary depending upon vehicle load and speed, road and weather conditions, trip length, etc.

Drive smoothly and keep a lookout ahead

Vehicles use the most fuel when they are accelerating.

- ▶ Avoid unnecessary accelerating and braking.

Vehicles use the most fuel when they are accelerating. If you anticipate what is going to happen next, you will need to brake less and, thus, accelerate less. Let the vehicle coast whenever possible - for example when you see that the next traffic light is red.

Avoid full throttle

Driving at moderate speeds saves fuel and improves your mileage.

- ▶ Try and keep well below your car's maximum speed.

Accelerating gently reduces fuel consumption, engine wear, and does not disturb the environment.

Fuel consumption, exhaust emissions and engine noise increase disproportionately at high speeds. If you drive at approximately three quarters of top speed, fuel consumption will be reduced by one half. Never drive faster than the posted speed limit and weather conditions permit.

Reducing unnecessary idling

Even when your car is just idling it burns up fuel.

- ▶ Shut the engine off when you are not driving the vehicle.

- ▶ Do not warm up the vehicle by letting the engine run at idle.

The idling phase is automatically reduced for vehicles with the Start/Stop system. It is efficient to switch off the engine in vehicles without the Start-Stop-System when stopped at railroad crossings and long red lights. Turning the engine off for just 30-40 seconds saves more fuel than is burned by starting the engine again.

It takes a long time for the engine to warm up fully when it is running at idle. However, wear and noxious emissions are especially high when the engine is warming up. So you should drive away as soon as you start the engine and avoid running at high rpms while the engine is still warming up.

! Note

Do not leave engine idling unattended after starting. If warning lights should come on to indicate improper operation, they would go unheeded. Extended idling also produces heat, which could result in overheating or other damage to the vehicle or other property.

Regular maintenance

A badly tuned engine unnecessarily wastes a lot of fuel.

- ▶ Have your vehicle serviced at regular intervals.

By having your vehicle regularly serviced by an Audi dealer helps to ensure that it runs properly and economically. The condition of your vehicle not only affects its safety and ability to hold its value, it also affects **fuel consumption**.

Check your oil each time you fill your tank.

The amount of oil used is related to engine load and speed.

It is normal for the oil consumption of a new engine to reach its lowest value after a certain mileage has been driven. ▶

You must drive your vehicle about 3,000 miles (5,000 kilometers) before you can properly assess oil consumption.

This also applies to fuel consumption and engine output.

Note

- Have your vehicle maintained properly and in accordance with the service recommendations in your Warranty & Maintenance booklet. Lack of proper maintenance as well as improper use of the vehicle will impair the function of the emission control system and could lead to damage.
- Do not alter or remove any component of the Emission Control System unless approved by the manufacturer.
- Do not alter or remove any device, such as heat shields, switches, ignition wires, valves, which are designed to protect your vehicle's Emission Control System and other important vehicle components.

Fewer short trips

Fuel consumption will always be relatively high on short trips.

- ▶ Try to avoid driving short distances with a cold engine.

The engine and catalytic converter have to reach their optimal **operating temperature** to reduce fuel consumption and noxious emissions effectively.

Just after starting, a cold engine in a mid-size car only achieves a fuel economy of 6-8 miles per gallon (30-40 l/100 km). After about a half a mile, fuel economy climbs to 12 mpg (20 l/100 km). After about 2.5 miles (4 km), the engine is at its proper operating temperature and fuel economy has reached a normal level. So you can see that you should avoid short trips whenever possible.

The **outside temperature** is also critical in this regard. Your car consumes more fuel in the winter than in the summer.

Trailer towing

Driving with a trailer

General information

Your Audi was designed primarily for passenger transportation.

If you plan to tow a trailer, please remember that the additional load will affect durability, economy and performance.

Trailer towing not only places more stress on the vehicle, it also calls for more concentration from the driver.

For this reason, always follow the operating and driving instructions provided and use common sense.

Note

If you are going to tow a trailer, you must activate the trailer operation mode
⇒ page 212, Operating instructions.

Technical requirements

Trailer hitch

Use a weight-carrying hitch conforming to the gross trailer weight. The hitch must be suitable for your vehicle and trailer and must be mounted securely on the vehicle's chassis at a *technically sound* location. Use only a trailer hitch with a removable ball mount. Always check with the trailer hitch manufacturer to make sure that you are using the correct hitch.

Do not use a bumper hitch.

The hitch must be installed in such a way that it does not interfere with the impact-absorbing bumper system. No modifications should be made to the vehicle exhaust and brake systems. From time to time, check that all hitch mounting bolts remain securely fastened.

When you are not towing a trailer, remove the trailer hitch ball mount. This prevents the hitch from causing damage should your vehicle be struck from behind ⇒ .

Trailer brakes

If your trailer is equipped with a braking system, check to be sure that it conforms to all regulations.

The trailer hydraulic brake system must not be directly connected to the vehicle's hydraulic brake system.

Safety chains

Always use safety chains between your vehicle and the trailer.

Trailer lights

Trailer lights must meet all regulations. Be sure to check with your Audi dealer for correct wiring, switches and relays.

Mirrors

If you are unable to see the traffic behind you using the regular outside mirrors, then you *must* install extended mirrors. It is important that you *always* have clear vision to the rear.

WARNING

After removing the trailer hitch, do not store it in your vehicle. In case of sudden braking, the hitch could fly forward and injure you or your passengers.

Operating instructions

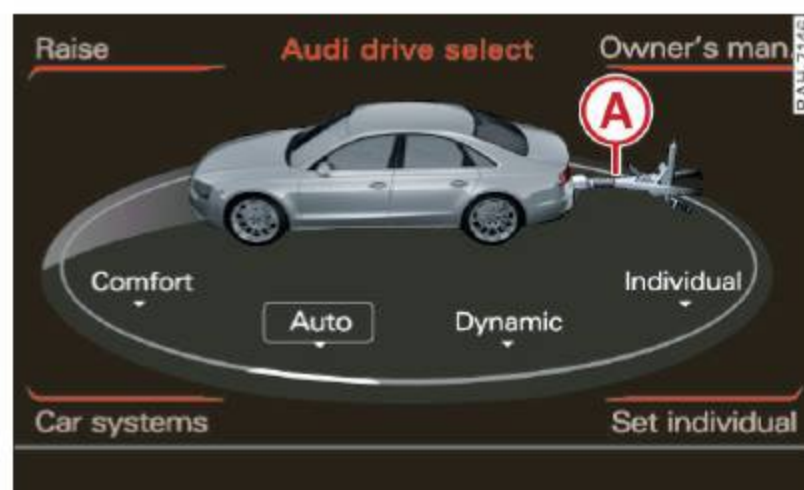

Fig. 189 MMI display: towing mode on

Maximum trailer weight

A trailer for your vehicle is limited to a typical class 1 or class 2 trailer. ►

Trailer load distribution

Be sure the load in the trailer is held securely in place to prevent it from shifting forward, backward or sideways.

Never allow a passenger to ride in a trailer
⇒ ⚠ in *Driving instructions* on page 214.

Engine cooling system

Towing a trailer makes the engine work harder. It is important that the cooling system's performance is up to the additional load. Make sure that the cooling system has enough fluid.

Tire pressure

When towing a trailer, inflate the tires of your vehicle to the cold tire pressure listed under "Full load" on the label located on the driver's side B-pillar (visible when the door is open). Inflate trailer tires to trailer and tire manufacturers' specifications.

Lights

Check to make sure both vehicle and trailer lights are working properly.

Safety chains

Be sure trailer safety chains are properly connected from the trailer to the hitch on the vehicle. Leave enough slack in the chains to permit turning corners. When you install safety chains, make sure they will not drag on the road when you are driving.

The chains should cross under the trailer tongue to prevent it from dropping in case of separation from the hitch.

Adjusting the Audi drive select

Make sure the vehicle is on a level surface **before** hitching up the trailer and **before** adjusting the tongue weight. The vehicle must be in **auto** or **comfort** driving mode and not raised ⇒ page 110, ⇒ ⚠.

Make sure that the vehicle is lowered. In Infotainment, select: CAR function button > **Lower** control button.

If you must drive under poor road conditions, you can raise the vehicle **after** coupling the trailer or **after** adjusting the tongue weight ⇒ page 112.

⚠ Note

- Changes in temperature or load can affect the height of the vehicle.
- Always select auto or comfort mode. Otherwise, the tongue load specified for your vehicle will no longer be applicable.

Driving instructions

Driving with a trailer always requires extra care and consideration.

To obtain the best possible handling of vehicle and trailer, please note the following:

- ▶ Do not tow a loaded trailer when your car itself is not loaded.
- ▶ Be especially careful when passing other vehicles.
- ▶ Observe speed limits.
- ▶ Do not drive at the maximum permissible speed.
- ▶ Always apply brakes early.
- ▶ Monitor the temperature gauge.

Weight distribution

Towing a loaded trailer with an empty car results in a highly unstable distribution of weight. If this cannot be avoided, drive at very low speeds only to avoid the risk of losing steering control.

A "balanced" rig is easier to operate and control. This means that the tow vehicle should be loaded to the extent possible and permissible, while keeping the trailer as light as possible under the circumstances. Whenever possible, transfer some cargo to the luggage compartment of the tow vehicle while observing tongue load requirements and vehicle loading considerations.

Speed

The higher the speed, the more difficult it becomes for the driver to control the rig. Do not ▶

drive at the maximum permissible speed. Reduce your speed even more if load, weather or wind conditions are unfavorable - particularly when going downhill.

Reduce vehicle speed **immediately** if the trailer shows the slightest sign of swaying. **Do not try to stop the swaying by accelerating.**

Observe speed limits. In some areas, speeds for vehicles towing trailers are lower than for regular vehicles.

Always apply brakes early. When driving downhill, shift into a lower gear to use the engine braking effect to slow the vehicle. Use of the brakes alone can cause them to overheat and fail.

Coolant temperature

The coolant temperature gauge ⇒ *page 10* must be observed carefully. The coolant temperature can increase if you drive on long inclines in a low gear at high engine speeds. Reduce your speed immediately if the LEDs in the top part of the display turn on.

For more information about indicator lights, refer to  ⇒ *page 16*.

WARNING

Anyone not properly restrained in a moving vehicle is at a much greater risk in an accident. Never let anyone ride in your car who is not properly wearing the restraints provided by Audi.

Trailer towing tips

Important to know

Your vehicle handles differently when towing a trailer because of the additional weight and different weight distribution. Safety, performance and economy will greatly depend on how carefully you load your trailer and operate your rig.

Before you actually tow your trailer, practice turning, stopping and backing up in an area away from traffic. Keep practicing until you

have become completely familiar with the way your vehicle-trailer combination behaves and responds.

Backing up is difficult and requires practice. Backing up with a trailer generally requires steering action opposite to that when backing up your vehicle without a trailer.

Maintain a greater distance between your vehicle and the one in front of you. You will need more room to stop. To compensate for the trailer, you will need a larger than normal turning radius.

When passing, remember that you cannot accelerate as fast as you normally would because of the added load. Make sure you have enough room to pass. After passing, allow plenty of room for your trailer before changing lanes again.

Avoid jerky starts, sharp turns or rapid lane changes.

Tips

- Do not tow a trailer during the break-in period of your vehicle.
- If you tow a trailer, your Audi may require more frequent maintenance due to the extra load ⇒ *page 292*.

Parking on a slope

Do not park on a slope with a trailer. If it cannot be avoided, do so only after doing the following:

When parking:

- ▶ Apply the foot brake.
- ▶ Have someone place chocks under both the vehicle and the trailer wheels.
- ▶ With chocks in place, slowly release the brakes until the wheel chocks absorb the load.
- ▶ Turn the wheels towards the curb.
- ▶ Apply the parking brake.
- ▶ Select the P selector lever position.

When restarting after parking:

- ▶ Apply the foot brake.

- ▶ Start the engine.
- ▶ Select the D selector lever position.
- ▶ Release the parking brake and slowly pull out and away from the wheel chocks.
- ▶ Stop and have someone retrieve the wheel chocks.

Tips

If you move the selector lever of the automatic transmission to P before applying the parking brake and before blocking the wheels, you may have to use more force later to move the lever out of the P position.

Vehicle care and cleaning

General information

Regular, proper care helps to maintain your vehicle's value. It can also be a requirement when submitting warranty claims for corrosion damage and paint defects on the body.

The required cleaning and care products can be obtained from your authorized Audi dealer or a qualified workshop. Read and follow the instructions for use on the packaging.



WARNING

- Using cleaning and care products incorrectly can be dangerous to your health.
- Always store cleaning and care products out of reach of children to reduce the risk of poisoning.



For the sake of the environment

- Preferably use environmentally-friendly products when buying cleaning agents.
- Do not dispose of leftover cleaning and care products with household trash.

Car washes

The longer that deposits such as insects, bird droppings, tree sap or road salt remain on the vehicle, the more the surface can be damaged. High temperatures such as those caused by sunlight increase the corrosive effect.

Before washing, wet heavy deposits with plenty of water.

Also, wash the underside of your vehicle once road salt stops being used for the season.

Pressure washers

When washing your vehicles with a pressure washer, always follow the operating instructions provided with the pressure washer. This is especially important in regard to the pressure and spraying distance. Do not aim the spray directly at seals on side windows, doors,

the hood, the rear lid or the sunroof* or at tires, rubber hoses, insulating material, sensors* or camera lenses*. Keep a distance of at least 16 inches (40 cm).

Do not remove snow and ice with a pressure washer.

Never use rotary nozzles or high pressure nozzles.

The water temperature must not be above 140 °F (60 °C).

Automatic car washes

Spray off the vehicle before washing.

Make sure that the windows and roof* are closed and the windshield wipers are off. Follow instructions from the car wash operator, especially if there are accessories attached to your vehicle.

If possible, use car washes that do not have brushes.

Only use car washes where the vehicle remains stationary and the washing equipment moves around the vehicle when washing and drying. Car washes that move the vehicle through the car wash using a chain are not recommended.

Washing by hand

Clean the vehicle starting from the top and working down using a soft sponge or cleaning brush. Use solvent-free cleaning products.

Washing vehicles with matte finish paint by hand

To avoid damaging the paint when washing, first remove dust and large particles from your vehicle. Insects, grease spots and fingerprints are best removed with a special cleaner for matte finish paint.

Apply the product using a microfiber cloth. To avoid damaging the paint surface, do not use too much pressure.

Rinse the vehicle thoroughly with water. Then clean using a neutral shampoo and a soft microfiber cloth. ►

Rinse the vehicle thoroughly again and let it air dry. Remove any water residue using a shammy.

Stubborn deposits such as bird droppings or tree sap are best removed with plenty of water and a microfiber cloth.

! WARNING

- Only wash the vehicle when the ignition is off and follow the instructions from the car wash operator to reduce the risk of accidents.
- To reduce the risk of cuts, protect yourself from sharp metal components when washing the underbody or the inside of the wheel housings.
- After washing the vehicle, the braking effect may be delayed due to moisture on the brake rotors or ice in the winter. The brakes must be dried first with a few careful brake applications.

! Note

- If you wash the vehicle in an automatic car wash, you must fold the exterior mirrors in to reduce the risk of damage to the mirrors. Power folding exterior mir-

- rors* must only be folded in and out using the power folding function.
- To prevent paint damage, do not wash the vehicle in direct sunlight.
- To reduce the risk of damage to the surface, do not use insect removing sponges, kitchen sponges or similar items.
- Matte finish painted vehicle components:
 - To reduce the risk of damage to the surface, do not use polishing agents or hard wax.
 - Never use car wash cycles that apply protective wax. It can destroy the matte finish effect.
 - Do not place any stickers or magnetic signs on vehicle parts painted with matte finish paint. The paint could be damaged when the stickers or magnets are removed.



For the sake of the environment

Only wash the vehicle in facilities specially designed for that purpose. This will reduce the risk of dirty water contaminated with oil from entering the sewer system.

Cleaning and care information

When cleaning and caring for individual vehicle components, refer to the following table. The information contained there is simply recommendations. For questions or for compo-

nents that are not listed, refer to an authorized Audi dealer or a qualified workshop. Also follow the information found in ⇒ .

Cleaning exterior

Component	Situation	Solution
Wiper blades	Dirty	⇒ page 54, <i>Cleaning windshield wiper blades</i>
Headlights/ tail lights	Dirty	Soft sponge with a mild soap solution ^{a)}
Sensors/ camera lenses	Dirty	Sensors: soft cloth with a solvent-free cleaning product Camera lenses: soft cloth with an alcohol-free cleaning solution
	Snow/ice	Hand brush/solvent-free de-icing spray
Wheels	Road salt	Water
	Brake dust	Acid-free special cleaning solution

Component	Situation	Solution
Exhaust tail pipes	Road salt	Water, cleaning solution suitable for stainless steel, if necessary
Decorative parts/trim	Dirty	Mild soap solution ^{a)} , a cleaning solution suitable for stainless steel, if necessary
Paint	Paint damage	Refer to the paint number on the vehicle data label, repair with touch up paint ⇒ <i>page 289</i>
	Spilled fuel	Rinse with water immediately
	Rust film	Rust film remover, then protect with hard wax; for questions, refer to an authorized Audi dealer or a qualified workshop
	Corrosion	Have it removed by an authorized Audi dealer or a qualified workshop
	Water no longer beads on the surface of clean paint	Protect with hard wax (at least twice per year)
	No shine even though paint has been protected/paint looks poor	Treat with suitable polish; then apply paint protectant if the polish that was used does not contain any protectant
Carbon parts	Dirty	Clean the same way as painted parts ⇒ <i>page 216, Car washes</i>

^{a)} Mild soap solution: maximum two tablespoons neutral soap in a liter of water

Cleaning interior

Component	Situation	Solution
Windows	Dirty	Glass cleaner, then wipe dry
Decorative parts/trim	Dirty	Mild soap solution ^{a)}
Plastic parts	Dirty	Damp cloth
	Heavily soiled	Mild soap solution ^{a)} , solvent-free plastic cleaning solution, if necessary
Displays	Dirty	Soft cloth with LCD cleaner
Controls	Dirty	Soft brush, then a soft cloth with a mild soap solution ^{a)}
Safety belts	Dirty	Mild soap solution ^{a)} , allow to dry before letting them retract

Component	Situation	Solution
Textiles, Vinyl, Alcantara	Stains adhering to the surface	Vacuum cleaner
	Water-based stains such as coffee, tea, blood, etc.	Absorbent cloth and mild soap solution ^{a)}
	Oil-based stains such as oil, make-up, etc.	Apply a mild soap solution ^{a)} , blot away the dissolved oil or dye, treat afterward with water, if necessary
	Special stains such as ballpoint pen, nail polish, latex paint, shoe polish, etc.	Special stain remover, blot with absorbent material, treat afterward with mild soap solution ^{a)} , if necessary
Natural leather	Fresh stains	Cotton cloth with a mild soap solution ^{a)}
	Water-based stains such as coffee, tea, blood, etc.	Fresh stains: absorbent cloth Dried stains: stain remover suitable for leather
	Oil-based stains such as oil, make-up, etc.	Fresh stains: absorbent cloth and stain remover suitable for leather dried stains: Oil cleaning spray
	Special stains such as ballpoint pen, nail polish, latex paint, shoe polish, etc.	Stain remover suitable for leather
	Care	Regularly apply conditioning cream that protects from light and penetrates into the material. Use specially-colored conditioning cream, if necessary.
Cooler	Dust and dirt	Clean the ventilation openings in the luggage compartment
	Dirty	Lukewarm water, mild soap solution ^{a)} if necessary, then dry
	Defrosting	Empty the refrigerator, switch it off and let it thaw with the door open, then dry
Carbon parts	Dirty	Clean the same way as plastic parts

^{a)} Mild soap solution: maximum two tablespoons neutral soap in a liter of water

 **WARNING**

The windshield may not be treated with water-repelling windshield coating agents. Unfavorable conditions such as wetness, darkness, or low sun can result in increased glare. Wiper blade chatter is also possible.

 **Note**

- **Headlights/tail lights**
- Never clean headlights or tail lights with a dry cloth or sponge.
- Do not use any cleaning product that contains alcohol, because they could cause cracks to form.

– Wheels

- Never use any paint polish or other abrasive materials.
- Damage to the protective layer on the rims such as stone chips or scratches must be repaired immediately.

– Sensors/camera lenses

- Never use warm or hot water to remove snow or ice from the camera lens. This could cause the lens to crack.
- Never use abrasive cleaning materials or alcohol to clean the camera lens. This could cause scratches and cracks.

– Windows

- Remove snow and ice on windows and exterior mirrors with a plastic scraper. To avoid scratches, move the scraper only in one direction and not back and forth.
- Never remove snow or ice from windows and mirrors using warm or hot water because this could cause cracks to form.
- To avoid damage to the rear window defogger, do not apply any stickers on the heating wires on the inside of the window.

– Decorative parts/trim

- Never use chrome care or cleaning products.

– Paint

- To reduce the risk of scratches, the vehicle must be free of dirt and dust before polishing or waxing.
- To prevent paint damage, do not polish or wax the vehicle in direct sunlight.
- To reduce the risk of paint damage, do not polish away rust film.

– Trim

- To reduce the risk of damage, do not treat the trim around the panorama sunroof with paint polish.

– Decorative decals

- To reduce the risk of damage, do not use any rough powder or abrasive cleaning products.

- To reduce the risk of damage, do not polish decorative parts that have a matte finish.

– Displays

- To avoid scratches, do not use dry cleaning methods on displays.

– Controls

- Make sure that no fluids enter the controls, because this could cause damage.

– Safety belts

- Do not remove the safety belts to clean them.
- Never clean safety belts or their components chemically or with corrosive fluids or solvents and never allow sharp objects to come into contact with the safety belts. This could cause damage to the belt webbing.
- If there is damage to the webbing, the connections, the retractors or the buckles, have them replaced by an authorized Audi dealer or a qualified workshop.

– Textiles/Vinyl/Alcantara

- Never treat Vinyl/Alcantara with leather care products, solvents, floor polish, shoe polish, stain remover or similar products.
- To avoid damage, have stubborn stains removed by an authorized Audi dealer or a qualified workshop.
- Never use steam cleaners, brushes, hard sponges, etc. when cleaning.
- Objects with sharp edges such as zippers, rivets on clothing or belts can cause damage to the surface.
- Open hook and loop fasteners, for example on clothing, can damage seat covers. Make sure hook and loop fasteners are closed.

– Natural leather

- Never treat leather with solvents, floor polish, shoe polish, stain remover or similar products.

- Objects with sharp edges such as zippers, rivets on clothing or belts can cause damage to the surface.
- Never use steam cleaners, brushes, hard sponges, etc. when cleaning.
- To help prevent the leather from fading, do not leave the vehicle in direct sunlight for long periods of time. If leaving the vehicle parked for long periods of time, you should cover the leather to protect it from direct sunlight.
- **Cooler**
 - Do not try to speed up the defrosting process by applying heat.
 - To help prevent health risks or damage to the cooler, do not use any abrasive cleaners, solvents, wax or strongly scented or aggressive cleaning products.
 - Do not clean the cooler with rough cleaning tools such as steel wool.

Tips

- Insects are easier to remove from paint that has been freshly waxed.
- Regular waxing can prevent rust film from forming.

Fuel supply and filling your fuel tank

Gasoline

Fuel supply

Applies to vehicles: with gasoline engine

Using the right fuel helps keep the environment clean and prevents engine damage.

Fuel recommendation

The fuel recommended for your vehicle is **unleaded premium** grade gasoline. Audi recommends using TOP TIER Detergent Gasoline with a minimum octane rating of 91 AKI (95 RON). For more information on TOP TIER Detergent Gasoline, please go to the official website (www.toptiergas.com).

The recommended gasoline octane rating for your engine can also be found on a label located on the inside of the fuel filler flap. This rating may be specified as AKI or RON.

Your vehicle may also be operated using unleaded regular gasoline with a minimum octane rating of 87 AKI/91 RON. However, using 87 AKI/91 RON octane fuel will slightly reduce engine performance.

Use unleaded gasoline only. Unleaded gasoline is available throughout the USA, Canada, and in most European countries. We recommend that you do not take your vehicle to areas or countries where unleaded gasoline may not be available.

For more information on refueling your vehicle, see ⇒ *page 224*.

Octane rating

Octane rating indicates a gasoline's ability to resist engine damaging "knock" caused by premature ignition and detonation. Therefore, buying the correct grade of gasoline is very important to help prevent possible engine damage and a loss of engine performance.

Gasoline most commonly used in the United States and Canada has the following octane

ratings that can usually be found on the filler pump:

- Premium Grade: 91 - 96 AKI
- Regular Grade: 87 - 90 AKI

Explanation of the abbreviations:

AKI = **A**nti **K**nock **I**ndex = (R+M)/2 = (RON +MON)/2

RON = **R**esearch **O**ctane **N**umber

MON = **M**otor **O**ctane **N**umber.

Note

- Do not use any fuel with octane ratings lower than 87 AKI or 91 RON otherwise expensive engine damage will occur.
- Do **not** use leaded gasoline. The use of leaded gasoline will severely damage your vehicle's catalytic converter and its ability to control exhaust emissions.

Blended gasoline

Applies to vehicles: with gasoline engine

Use of gasoline containing alcohol or MTBE (methyl tertiary butyl ether)

You may use unleaded gasoline blended with alcohol or MTBE (commonly referred to as oxygenates) if the blended mixture meets the following criteria:

Blend of gasoline methanol (wood alcohol or methyl alcohol)

- Anti-knock index must be 87 AKI or higher.
- Blend must contain no more than 3% methanol.
- Blend must contain more than 2% co-solvents.

Blend of gasoline and ethanol (grain alcohol or ethyl alcohol)

- Anti-knock index must be 87 AKI or higher.
- Blend must not contain more than 10% ethanol.

Blend of gasoline and MTBE

- Anti-knock index must be 87 AKI or higher. ►

- Blend must contain not more than 15% MTBE.

Seasonally adjusted gasoline

Many gasoline grades are blended to perform especially well for winter or summer driving. During seasonal change-over, we suggest that you fill up at busy gas stations where the seasonal adjustment is more likely to be made in time.

Note

- Methanol fuels which do not meet these requirements may cause corrosion and damage to plastic and rubber components in the fuel system.
- Do not use fuels that fail to meet the specified criteria in this chapter.
- If you are unable to determine whether or not a particular fuel blend meets the specifications, ask your service station or its fuel supplier.
- Do not use fuel for which the contents cannot be identified.
- Fuel system damage and performance problems resulting from the use of fuels different from those specified are not the responsibility of Audi and are not covered under the New Vehicle or the Emission Control System Warranties.
- If you experience a loss of fuel economy or driveability and performance problems due to the use of one of these fuel blends, we recommend that you switch to unblended fuel.

Gasoline additives

Applies to vehicles: with gasoline engine

A major concern among many auto manufacturers is carbon deposit build-up caused by the type of gasoline you use.

Although gasoline grades differ from one manufacturer to another, they have certain things in common. All gasoline grades contain substances that can cause deposits to collect on vital engine parts, such as fuel injectors and intake valves. Although most gasoline

brands include additives to keep engine and fuel systems clean, they are not equally effective.

Audi recommends using TOP TIER Detergent Gasoline. For more information on TOP TIER Detergent Gasoline, please go to the official website (www.toptiergas.com).

After an extended period of using inadequate fuels, carbon deposit build-ups can rob your engine of peak performance.

Note

Damage or malfunction due to poor fuel quality is not covered by the Audi New Vehicle Limited Warranty.

Diesel fuel

Applies to vehicles: with diesel engine

Always use ULSD (Ultra Low Sulfur Diesel) sulfur content 15 ppm or less.

The ULSD (Ultra Low Sulfur Diesel) meets the ASTM-D-975 (grade 2).

Diesel fuel with a higher concentration than ULSD-Diesel No. 2 ASTM D975 and Bio-diesel with a higher concentration than 5 % like B11, B20 or B100 are strictly prohibited.

Service station fuel pumps are labeled with the correct fuel information for easy recognition by the user. If the diesel fuel pump is not labeled ask the station operator what fuel is being dispensed before filling up your vehicle.

Service stations offering Diesel fuel are generally located on truck routes or major highways. Directories of Diesel fuel stations are usually available at Diesel fuel stations.

Some states in the USA require permits to purchase Diesel fuel. Check with your State Motor Vehicle Department.

Diesel fuel may not be available outside the USA and Canada. Be sure to check before traveling to other countries. ▶

Winter operation

At temperatures below 20° F (-7° C), Diesel fuel No. 2 loses its fluidity due to wax separation, which may clog the fuel filter or tank filter and keep the engine from running.

To help the filter from being clogged by wax, the fuel filter in your vehicle is automatically preheated. Preheating the fuel filter makes operation of your vehicle possible with Diesel fuel No. 2 down to -10° F (-24° C).

If you expect temperatures below 5° F (-15° C) ask your fuel dealer whether their Diesel fuel No. 2 is sufficiently winterized for the prevailing and expected temperatures.

If not winterized or insufficiently winterized Diesel fuel has already thickened to the extent that the engine will not start, warm the vehicle up by leaving it in a heated garage.

It is normal that the engine noise level (dieseling) is louder during the warm-up period in winter. It is also normal when whitish-blue smoke comes out of the tailpipe after starting and during warm-up. The amount of smoke depends on the outside temperature.

Do not let your Diesel engine idle unnecessarily after a cold start. Driving off slowly will shorten the warm-up period.

WARNING

- Never use “starting assist fluids.” They may be potentially explosive or cause a “run-away” engine condition. This could result in serious engine damage and personal injury.
- Never use fuel line anti-freeze offered for gasoline engines.

Note

- Your Diesel engine has been specifically designed to operate only on Ultra Low Sulfur Diesel fuel. Therefore, never use home heating oil or regular gasoline. The properties of these fuels may cause serious damage to the fuel injection system and to the engine. Using these fuels can

cause expensive engine repairs and will also adversely affect your New Vehicle Limited Warranty.

- If Diesel fuel should get on any rubber hose, it must be wiped off immediately. Then wash the contaminated hose portion with soap and warm water. Do not allow Diesel fuel to remain on connecting hoses. They may develop leaks and cause serious damage.

Fuel tank

Fuel filler neck

The fuel filler neck is located on the right rear side panel behind the fuel filler flap.

If the power locking system should fail, you can still open the flap manually - for detailed instructions see ⇒ *page 227*.

You can find the fuel tank capacity of your vehicle in ⇒ *page 290*.

The label on the inside of the fuel filler flap tells you the correct fuel for your vehicle. For more information about fuel specifications, see ⇒ *page 222*.

Your vehicle fuel tank has an onboard refueling vapor recovery system. This feature helps to prevent fuel vapors from escaping from the tank and polluting the environment while you refuel your vehicle. In order to fill the tank properly while protecting the environment, please follow this refueling procedure carefully.

WARNING

Under normal operating conditions, never carry additional fuel containers in your car. Gas canisters and other containers used to transport fuel can be dangerous. Such containers, full or empty, may leak and could cause a fire in a collision. If you must transport fuel to use for your lawn mower, snow blower, etc., be very careful and always observe local and state laws regarding the use, transportation and storage of such fuel containers. Make certain the

container meets industry standards (ANSI/ASTM F852 - 86).

! Note

Never drive your vehicle until the fuel tank is completely empty. The irregular supply of fuel can cause misfiring. Gasoline could enter the exhaust system and damage the catalytic converter.

Refuelling



Fig. 190 Right rear vehicle side: Opening the fuel filler flap



Fig. 191 Fuel filler flap with attached fuel cap

When activating the central locking, the fuel filler flap is automatically unlocked or locked. Refuel the vehicle with the ignition switched off.

Taking the fuel cap off

- ▶ Press the left side of the fuel filler flap to open it ⇒ *fig. 190* - arrow -.
- ▶ Unscrew fuel filler cap counter-clockwise and hang it on the fuel filler flap ⇒ *fig. 191*.
- ▶ Check the label on the inside of the fuel filler flap to determine if the vehicle must be fueled with gasoline or diesel fuel.

Refuelling procedure

- ▶ Insert the fuel nozzle from the gasoline pump into the fuel filler neck as far as it will go.
- ▶ Select a medium refuelling rate so that the nozzle switches off automatically when the tank is full.

Putting the fuel cap back on

- ▶ After filling your tank, twist the fuel filler cap clockwise as far as it will go.
- ▶ Close the fuel filler flap.

To avoid fuel spilling or evaporating from the fuel tank always close fuel filler cap properly and completely. An improperly closed fuel filler cap may also cause the MIL lamp ⇒ *page 29* to come on (only vehicles with gasoline engine).

! WARNING

Improper refueling or handling of fuel can cause fire, explosion and severe burns.

- Fuel is highly flammable and can cause severe burns and other injuries.
- Failure to shut the engine off while refueling and/or to insert the pump nozzle fully into the fuel filler neck could cause fuel to spray out of filler neck or to overflow. Fuel spray and overflowing fuel can cause a fire.
- Never use a cellular telephone while refueling. The electromagnetic radiation can cause sparks that can ignite fuel vapors and cause a fire.
- Never get back into your vehicle while refueling. If in exceptional circumstances you must get back in your vehicle while refueling, make certain that you close the door and touch metal to discharge static electricity before touching the filler nozzle again. Static electricity can cause sparks that can ignite fuel vapors released during refueling.
- Never smoke or have an open flame anywhere in or near your vehicle when refueling or filling a portable fuel container.

- For your safety, we strongly recommend that you do not travel with a portable fuel container in your vehicle. The container, full or empty may leak and could cause a fire, especially in a crash.
- If, under exceptional circumstances, you must transport a portable fuel container, please observe the following:
 - Never fill a portable fuel container while it is anywhere in or on the vehicle (for example, in the luggage compartment, or on the trunk). Static electricity can build up while filling and can ignite fuel vapors causing a fire.
 - Always place a portable fuel container on the ground before filling.
 - Always keep the filler nozzle completely inside the portable container before and during filling.
 - If filling a portable container made of metal, the filler nozzle must always be in contact with the container. This will help prevent static electricity from discharging and cause a fire.
 - Never spill fuel inside the vehicle or luggage compartment. Fuel vapors are highly flammable.
 - Always observe local and state/provincial laws regarding the use, storage and transportation of fuel containers.
 - Make certain the fuel container meets industry standards (ANSI / ASTM F852-86).

Note

If any fuel has spilled onto the car, it should be removed immediately to prevent damage to the paint.

For the sake of the environment

As soon as the correctly operated nozzle switches off automatically for the first time, the tank is full. Do not try to add more fuel because fuel may spill out. In addition, the expansion space in the fuel tank will be filled - causing the fuel to

overflow when it becomes warm and pollute the environment.

Tips

- Running your engine while refuelling may cause vapors to escape or even cause fuel to spill out of the tank. This would then shut off the fuel nozzle before the tank is full.
- Do not refuel your vehicle with the ignition switched on. The fuel gauge may otherwise not indicate the correct fuel level after refuelling.
- Diesel vehicles* are equipped with a diesel misfueling protector. It allows the vehicle to be fueled only with a diesel fuel pump nozzle. A worn or damaged nozzle or a nozzle that is too small may not be able to open the diesel misfueling protector. If this is the case, try turning the nozzle before inserting it in the fuel filler neck, use a different fuel pump or see your authorized Audi dealer or authorized repair facility for assistance.
- The fuel filler flap of your vehicle is not locked when you lock the vehicle from the inside.

Fuel filler flap emergency release

You can open the fuel filler flap by hand if the power locking system should fail.

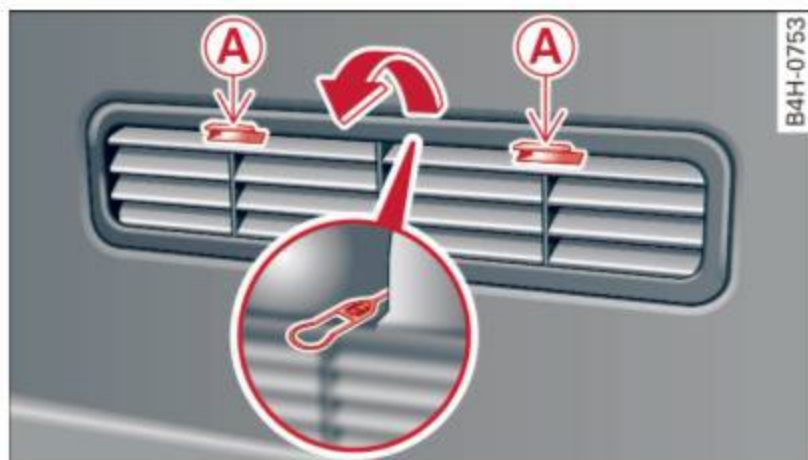

Fig. 192 Vehicles with selective catalytic reduction: Right side trim panel



Fig. 193 Right side trim panel in the luggage compartment: emergency release mechanism

The emergency release mechanism is located behind the right side trim panel in the luggage compartment. In vehicles with selective catalytic reduction*, remove the vent grille first:

- ▶ Press both tabs **A** ⇒ fig. 192 and tilt the vent grille downward. You can then remove the grille upward.
- ▶ Loosen the loop ⇒ fig. 193 from the retainer and then pull on the loop carefully ⇒ **!**.
- ▶ Press on the left side of the fuel filler door to open ⇒ page 225, fig. 190.

! Note

Only pull on the loop until you feel resistance. You will not hear it release. Otherwise you could damage the emergency release mechanism.

Selective catalytic reduction

General information

Applies to vehicles: with diesel engine

On vehicles with selective catalytic reduction, an urea solution (AdBlue) is injected into the exhaust system before a nitrogen oxide catalytic converter to reduce nitrogen emissions.

The AdBlue is stored in a separate tank in the vehicle. The AdBlue usage accounts for approximately 0.5% to 1.2% of the diesel fuel that is used.

You must refill the AdBlue or have it refilled by your authorized Audi dealer or qualified workshop as soon as the AdBlue refill message appears in the instrument cluster ⇒ page 229.

! WARNING

Failure to heed AdBlue refill information in the instrument cluster can prevent the vehicle from being started and driven. If the vehicle cannot be driven and an emergency arises, personal injury can occur.

- Always have the AdBlue tank refilled well before the tank runs dry.

i Tips

- The instrument cluster display indicates the distance remaining that can be driven ⇒ page 228. If the AdBlue tank is completely empty, the engine will not start again after the ignition is switched off.
- AdBlue is required by law to operate this vehicle.

Indicator in the instrument cluster display

Applies to vehicles: with diesel engine

The display indicates if the AdBlue level is low or if it was filled incorrectly.



Fig. 194 Instrument cluster: indicator in the display

AdBlue level low

You will be informed if the AdBlue in the tank drops below a certain level.

Please refill AdBlue. Range 1500 miles (2400 km)

This indicator appears when there is only enough AdBlue left to drive the distance indicated in the driver information system. Please add AdBlue.

AdBlue Refill AdBlue! Cannot start engine in 600 miles (1000 km)! See owner's manual

This indicator appears when there is only enough AdBlue left to drive the distance indicated in the driver information system. Please add AdBlue. Otherwise the engine will not start again if you stop it once the distance indicated has been driven.

AdBlue Refill AdBlue! No restart! See owner's manual

This message appears when the AdBlue tank is empty. Please add AdBlue. Otherwise you will not be able to start the engine again once you stop it.

When the minimum AdBlue level has been reached, you must add AdBlue ⇒ page 229.

Filling incorrectly

If the AdBlue tank was filled with a different fluid than AdBlue and the system detects that it is incorrect, a message will appear.

AdBlue AdBlue: System fault No restart in 600 miles (1000 km)! See owner's manual

This message appears when it is only possible to drive the distance indicated in the driver information system. Drive to the nearest qualified workshop to have the malfunction repaired. Otherwise the engine will not start again if you stop it once the distance indicated has been driven.

AdBlue AdBlue: System fault No restart! See owner's manual

This message appears if the system detects it was filled incorrectly. Drive immediately to the nearest qualified workshop to have the malfunction repaired. Otherwise you will not be able to start the engine again once you stop it.

Filling AdBlue

Applies to vehicles: with diesel engine

A special refill bottle must be used to fill the AdBlue.



Fig. 195 Right rear vehicle side: removing the AdBlue cap

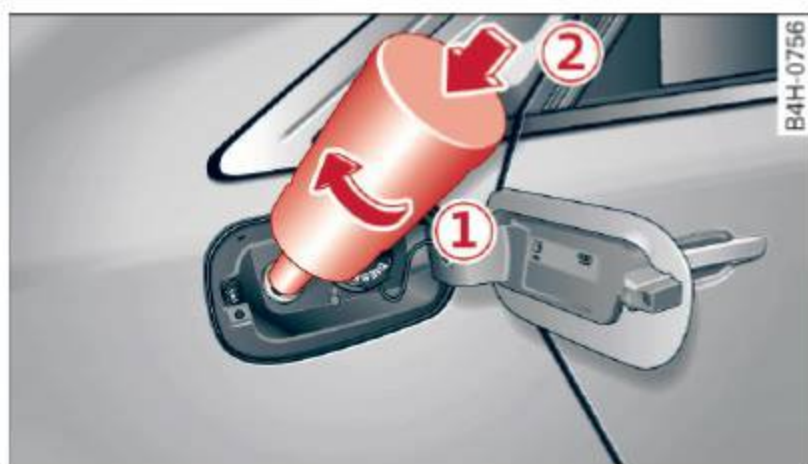

Fig. 196 AdBlue filler tube: inserting the refill bottle

The AdBlue filler tube is located near the diesel filler tube. Always add 1 gallon (3.8 liters) of AdBlue (two bottles). This is the minimum amount required to ensure the system detects the refilling and to start the engine. The AdBlue tank capacity is approximately 6 gallons (23 liters).

Opening the filler tube and adding AdBlue

Requirement: The request to add AdBlue must appear in the instrument cluster display.

- ▶ Switch the ignition off.
- ▶ Open the tank cover ⇒ *page 225*.
- ▶ Turn the cap counterclockwise with the lug wrench from the vehicle tool kit to remove it ⇒ *fig. 195*.
- ▶ Remove the cap from the refill bottle.
- ▶ Position the refill bottle on the filler tube and turn the bottle clockwise until it stops turning ① ⇒ *fig. 196*.

- ▶ Press lightly against the bottom of the bottle ② to empty it. Continue pressing the bottom of the bottle until it is empty or until fluid stops flowing into the tank.
- ▶ Turn the bottle to the left without pressing on the bottom.

Closing the filler tube

- ▶ Turn the cap clockwise on the filler tube with the lug wrench until you hear it tighten completely.
- ▶ Close the tank cover.

After filling

The vehicle must be driven. The system may take up to two minutes to detect that the AdBlue has been filled.

- ▶ If there was no AdBlue left in the tank and a range of **0 mi (0 km)** was displayed in the instrument cluster, switch the ignition on for about 15 seconds before starting the engine.

⚠ WARNING

AdBlue can irritate the skin, eyes and respiratory system. If there is contact with the fluid, flush immediately with plenty of water. Consult a physician if necessary.

! Note

- Only use AdBlue that conforms to the standard ISO 22241-1. Do not mix any additives with the AdBlue and do not dilute it with water.
- AdBlue is not a diesel additive. Do not add it to the diesel tank. If AdBlue is mixed with diesel fuel, it can lead to damage to the engine and the AdBlue tank system. The Limited New Vehicle Warranty does not cover such damage.
- AdBlue attacks surfaces such as painted vehicle components, plastic and carpet. Remove the fluid as quickly as possible with a damp cloth and plenty of cold water. If the AdBlue has already crystallized, use warm water and a sponge.

AdBlue residue that is not removed will crystallize and can damage the affected surface.

- Do not store the refill bottle in the vehicle. If it leaks, the escaping AdBlue could damage the vehicle interior.
- Do not allow AdBlue to come into contact with clothing. If there is contact with the fluid, flush immediately with plenty of water.



Tips

- You can obtain refill bottles from any authorized Audi dealer or other qualified workshop.
- Follow the AdBlue manufacturer's instructions for usage and storage.

Checking and filling

Engine hood

Releasing the engine hood

The engine hood is released from inside the vehicle.

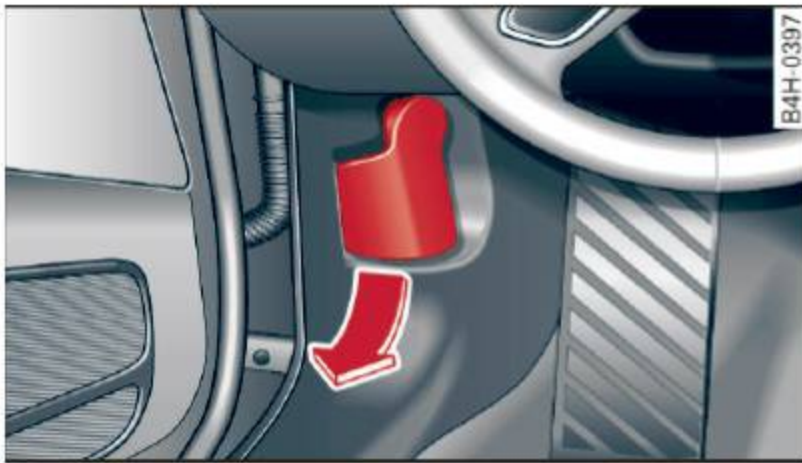

Fig. 197 Driver footwell: release lever



Fig. 198 Rocker switch under the hood

Make sure the wiper arms are not raised up from the windshield. Otherwise the paint could be damaged.

- ▶ Pull the lever under the instrument panel in the direction of the arrow ⇒ *fig. 197*.
- ▶ Raise the hood slightly ⇒ ⚠.
- ▶ Press the rocker switch under the hood upward ⇒ *fig. 198*. This releases the catch.
- ▶ Open the hood.

⚠ WARNING

Hot engine coolant can burn you.

- To reduce the risk of being burned, never open the hood if you see or hear steam or coolant escaping from the engine compartment. Wait until no steam or coolant can be seen or heard before carefully opening the hood.

Working in the engine compartment

Be especially careful whenever you work in the engine compartment.

Whenever you must perform any work in the engine compartment, for example checking and filling different fluids, there is a risk of injury, burns and accidents. To prevent personal injury always observe the following **WARNINGS**. The engine compartment of any vehicle is a hazardous area ⇒ ⚠.

⚠ WARNING

To help avoid injury, before you check anything under the hood:

- Turn off the engine.
- Switch off the ignition.
- Apply the parking brake.
- Move selector lever to “P” (Park).
- Always let the engine cool down. Hot components will burn skin on contact.
- To reduce the risk of being burned, never open the hood if you see or hear steam or coolant escaping from the engine compartment. Wait until no steam or coolant can be seen or heard before carefully opening the hood.
- Keep children away from the engine compartment.
- Never spill fluids on hot engine components. They can cause a fire.
- Never touch the radiator fan. The auxiliary electric fan is temperature controlled and can switch on suddenly.
- Never open the coolant reservoir cap when the engine is still warm. The coolant system is pressurized and hot coolant could spray out.
- Protect your face, hands and arm from steam or hot engine coolant by placing a thick rag over the cap when you open the coolant reservoir.
- Do not remove the engine cover under any circumstances. This increases the risk of burns.
- If work on the fuel system or the electrical system is necessary:

- Always disconnect the battery.
- Never smoke or work near heaters or open flames. Fluids in the engine compartment could start a fire.
- Keep an approved fire extinguisher immediately available.
- To avoid electrical shock and personal injury while the engine is running or being started, never touch:
 - Ignition cables
 - Other components of the high voltage electronic ignition system.
- If you must perform a check or repair with the engine running:
 - First, fully apply the parking brake, move selector lever to “P” (Park).
 - Always use extreme caution to prevent clothing, jewelry, or long hair from getting caught in the radiator fan, V-belts or other moving parts, or from contacting hot parts. Tie back hair before starting, and do not wear clothing that will hang or droop into the engine.
- Minimize exposure to emission and chemical hazards ⇒ ⚠.

WARNING

- California Proposition 65 Warning:
- Engine exhaust, some of its constituents, and certain vehicle components contain or emit chemicals known to the State of California to cause cancer and birth defects and reproductive harm. In addition, certain fluids contained in vehicles and certain products of component wear contain or emit chemicals known to the State of California to cause cancer and birth defects or other reproductive harm.

- Battery posts, terminals and related accessories contain lead and lead compounds, chemicals known to the State of California to cause cancer and reproductive harms. Wash hands after handling.

Note

When adding fluids, always make sure that they are poured into the proper container or filler opening, otherwise serious damage to vehicle systems will occur.

For the sake of the environment

To detect leaks in time, inspect the vehicle floor pan from underneath regularly. If you see spots from oil or other vehicle fluids, have your vehicle inspected by an authorized Audi dealer.

Closing the engine hood

- ▶ Pull the hood down until the pressure from the struts is reduced.
- ▶ Let the hood *drop down* and latch in place. *Do not try to push it shut*; it may fail to engage ⇒ ⚠.

WARNING

- A hood that is not completely latched could fly up and block your view while driving.
- When you close the engine hood, check it to make sure the safety catch has properly engaged. The hood should be flush with the surrounding vehicle body parts.
 - If you notice while driving that the hood is not secured properly, stop at once and close it.

Engine compartment

Engine compartment overview

These are the most important items that you can check.

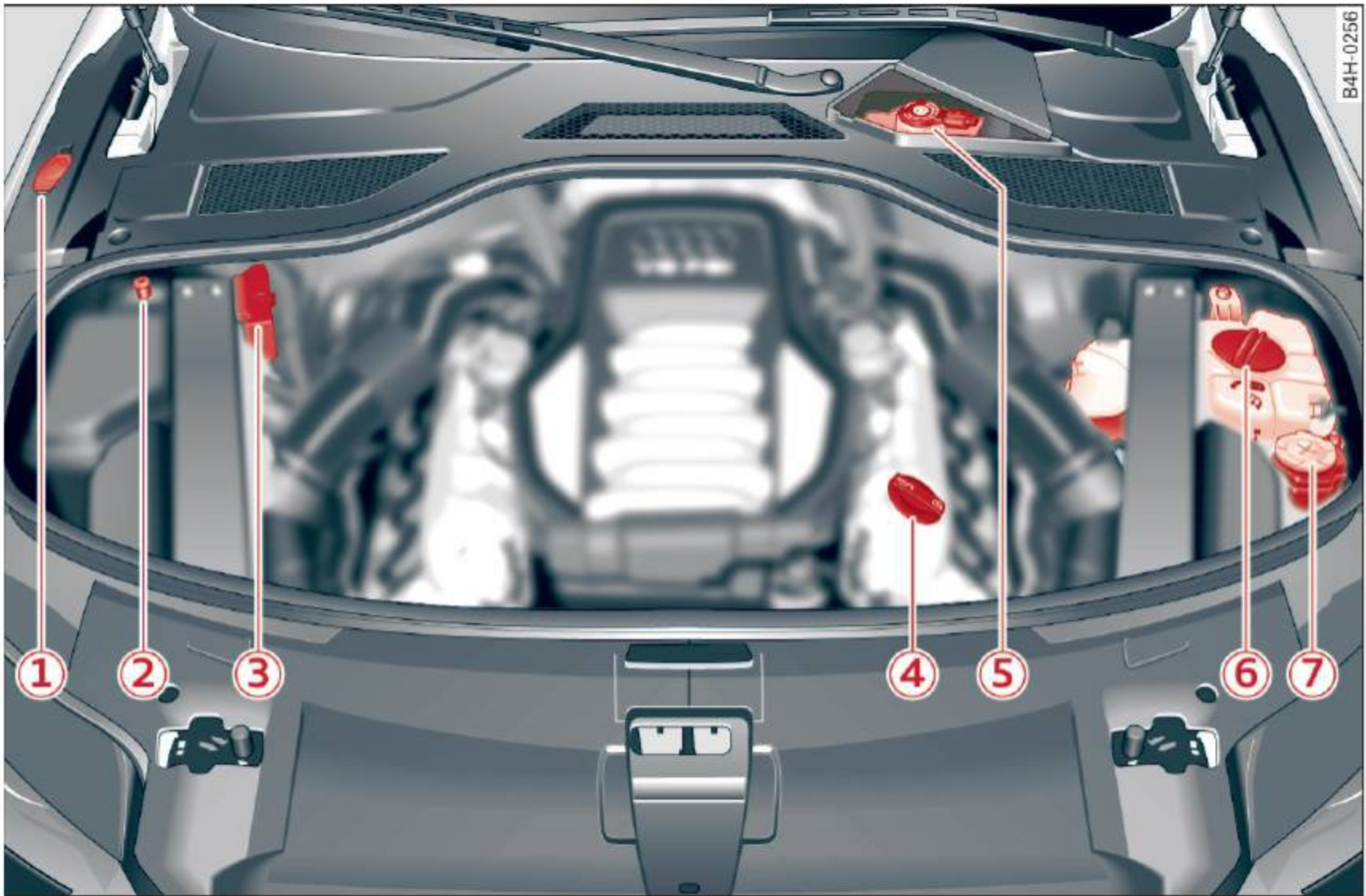

B4H-0256

Fig. 199 Typical layout for containers and engine oil filler cap

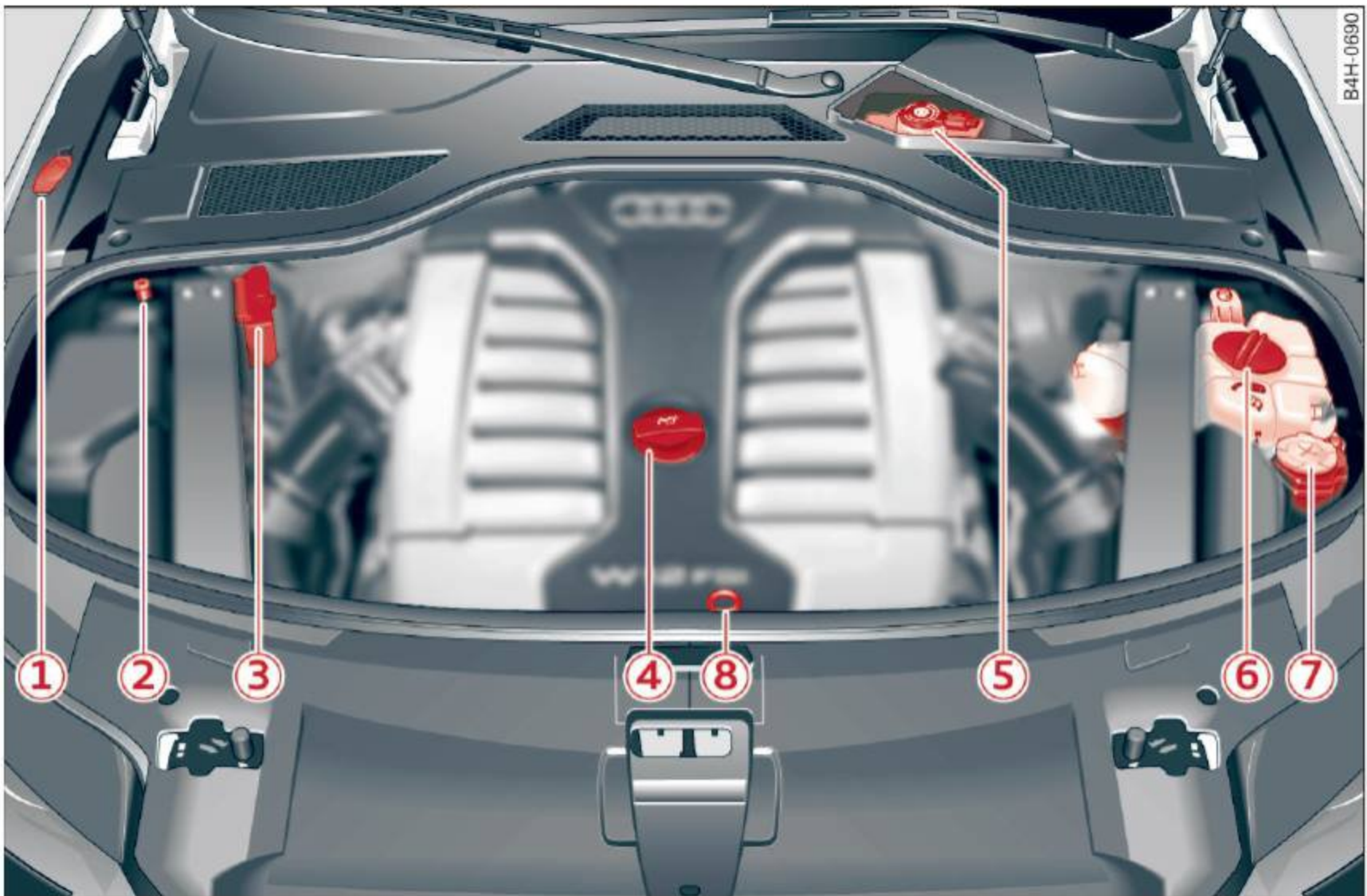

B4H-0690

Fig. 200 Layout of the reservoir, engine oil filling opening and oil dipstick for the W12 engine

- | | | |
|---|---|----------|
| ① | Windshield/headlight washer container (☞) | 247 |
| ② | Jump start point (-) with hex head screw | 245, 283 |
| ③ | Jump start point (+) under a cover | 245, 283 |
| ④ | Engine oil filler cap (☞) | 237 |
| ⑤ | Brake fluid reservoir (☞) | 242 |
| ⑥ | Coolant expansion tank (☞) | 240 |
| ⑦ | Power steering reservoir | 203 |
| ⑧ | Oil dipstick | 237 |

The engine oil filler neck (item ④) may be located in a different area depending on the version of the engine.



WARNING

Before you check anything in the engine compartment, always read and heed all WARNINGS ⇒ in *Working in the engine compartment* on page 231.

Engine oil

Engine oil specifications

The engine oil used in your Audi needs the right kind of oil.

The engine in your Audi is a sophisticated powerplant that was built to exacting specifications. This engine needs the right kind of engine oil that meets specifications regarding quality and viscosity so that it can run smoothly and reliably. Choosing the right oil and changing oil within the time and mileage intervals printed in your vehicle's Warranty & Maintenance booklet matters a lot more today than it did years ago. Audi has developed a special quality standard for engine oil that will help assure that your vehicle's engine will get the lubrication it needs for proper operation.

Modern engine lubrication has taken a quantum leap in the last few years. Many synthetic oils available today provide better engine lubrication that can outlast traditional petrole-

um-based oils, making them a smart choice for use throughout the life of your Audi.

Whether you use synthetic or petroleum-based engine oil, the oil that you use must conform to Audi's oil quality standard VW 502 00 (vehicles with gasoline engine) or VW 507 00 (vehicles with diesel engine) to help keep your vehicle's engine running smoothly and help prevent the formation of harmful deposits, sometimes called "sludge," that over time can lead to expensive repairs.

At the time of printing, engine oils available in the U.S. and Canada that meet the exacting specifications of Audi oil standard VW 502 00 (vehicles with gasoline engine) or VW 507 00 (vehicles with diesel engine) are synthetic engine oils. This does not mean, however, that every synthetic engine oil will meet Audi oil standard VW 502 00 (vehicles with gasoline engine) or VW 507 00 (vehicles with diesel engine). So always be sure that you use an approved oil.

To help prevent the formation of harmful deposits use only oil with the following specifications printed on the oil container:

- **Audi oil standard VW 502 00 (gasoline engine)**
- **Audi oil standard VW 507 00 (diesel engine)**

Oil container labels may carry the specification singly or in combination with other designations and oil quality standards.

Viscosity

Engine oils are graded according to their viscosity. The proper viscosity grade oil for your engine depends on climactic or seasonal conditions where you drive. You can use oil with a viscosity grade of SAE 5W40 across all temperature ranges for normal driving conditions.

However, if engine oil viscosity grade SAE 5W40 is not available, you can also use viscosity grade SAE 5W-30 or SAE 0W-40 as long as it meets Audi oil quality standard VW 502 00 (vehicles with gasoline engine) or VW 507 00 (vehicles with diesel engine) specifications. ►

Because engine oil that meets the Audi oil standard may not be available everywhere when you need it, we strongly recommend that you always carry with you an extra quart (liter) of oil that expressly conforms to the VW 502 00 (vehicles with gasoline engine) or VW 507 00 (vehicles with diesel engine) specification, in case you have to top off the oil while on the road.

Applies to vehicles with gasoline engine only: Only if the level of the oil is at or below the minimum mark on the oil dipstick - and no oil that expressly conforms to Audi oil standard VW 502 00 specifications is available - may you top off with a high quality engine oil, preferably synthetic-based, that meets ACEA A3 or API SM specifications, but even then, only in viscosity grades SAE 5W-40, SAE 5W-30, or SAE 0W-40. However, during the entire time between oil change intervals, never top off with more than a total of 0.5 qt/liter engine oil that does not conform to Audi oil specification VW 502 00.

Applies to vehicles with diesel engine only: Only if the level of the oil is at or below the minimum mark on the oil dipstick - and no oil that expressly conforms to Audi oil standard VW 507 00 specifications is available - may you top off with a high quality engine oil, that meets ACEA C3 or API CF specifications, but even then, only in viscosity grades SAE 5W-40, SAE 5W-30, or SAE 0W-40. However, during the entire time between oil change intervals, never top off with more than a total of 0.5 qt/liter engine oil that does not conform to Audi oil specification VW 507 00.

For more information about engine oil that has been approved for your vehicle, please contact either your authorized Audi dealer or Audi Customer Relations at 1 (800) 822-2834 or visit our web site at www.audiusa.com or www.audicanada.ca. Here you will also find a current list of oils (manufacturers, brand names etc.) that conform to Audi oil standard VW 502 00 (vehicles with gasoline engine) or VW 507 00 (vehicles with diesel engine).

Changing the engine oil

The engine oil and oil filter must be changed according to the mileage (kilometers) and time intervals specified in your vehicle's Warranty & Maintenance booklet. Do not exceed these intervals - harmful deposits from old engine oil can reduce engine performance and can lead to expensive engine repairs.

Changing the oil at the recommended intervals is so very important because the lubricating properties of oil decrease gradually during normal vehicle use. If you are not sure when you have your oil changed, ask your authorized Audi Service Advisor.

Under some circumstances the engine oil should even be changed more frequently. Change oil more often if you drive mostly short distances, operate the vehicle in dusty areas or mostly under stop-and-go traffic conditions, or when you use your vehicle where temperatures stay below freezing point for long periods.

Detergent additives in the oil will make fresh oil look dark after the engine has been running for a short time. This is normal and is not a reason to change the oil more often than recommended.

Damage or malfunctions due to lack of maintenance

It is essential that you change your oil at the recommended intervals using only engine oil that complies with Audi oil standard VW 502 00 (vehicles with gasoline engine) or VW 507 00 (vehicles with diesel engine). Your Limited New Vehicle Warranty does not cover damage or malfunctions due to failure to follow recommended maintenance and use requirements as set forth in the Audi Owner's Manual and Warranty & Maintenance booklet. Your dealer will have to deny warranty coverage unless you present to the dealer proof in the form of Service or Repair Orders that all scheduled maintenance was performed in a timely manner.

Engine oil consumption

The engine in your vehicle depends on an adequate amount of oil to lubricate and cool all of its moving parts.

In order to provide effective lubrication and cooling of internal engine components, all internal combustion engines consume a certain amount of oil. Oil consumption varies from engine to engine and may change significantly over the life of the engine. Typically, engines with a specified break-in period (see ⇒ page 207) consume more oil during the break-in period than they consume after oil consumption has stabilized.

Under normal conditions, the rate of oil consumption depends on the quality and viscosity of the oil, the RPM (revolutions per minute) at which the engine is operated, the ambient temperature and road conditions. Further factors are the amount of oil dilution from water condensation or fuel residue and the oxidation level of the oil. As any engine is subject to wear as mileage builds up, the oil consumption may increase over time until replacement of worn components may become necessary.

With all these variables coming into play, no standard rate of oil consumption can be established or specified. There is no alternative to regular and frequent checking of the oil level, see **Note**.

If the yellow engine oil level warning symbol in the instrument cluster  lights up, you should check the oil level as soon as possible ⇒ page 236 or ⇒ page 237. Top off the oil at your earliest convenience ⇒ page 237.

WARNING

Before you check anything in the engine compartment, always read and heed all WARNINGS ⇒  in *Working in the engine compartment* on page 231.

Note

Driving with an insufficient oil level is likely to cause severe damage to the engine.

Tips

- The oil pressure warning display  is not an indicator of the oil level. Do not rely on it. Instead, check the oil level in your engine at regular intervals, preferably each time you refuel, and always before going on a long trip.
- If you have the impression your engine consumes excessive amounts of oil, we recommend that you consult your Audi dealer to have the cause of your concern properly diagnosed. Keep in mind that the accurate measurement of oil consumption requires great care and may take some time. Your Audi dealer has instructions about how to measure oil consumption accurately.

Checking the engine oil level

Applies to vehicles: with oil level indicator

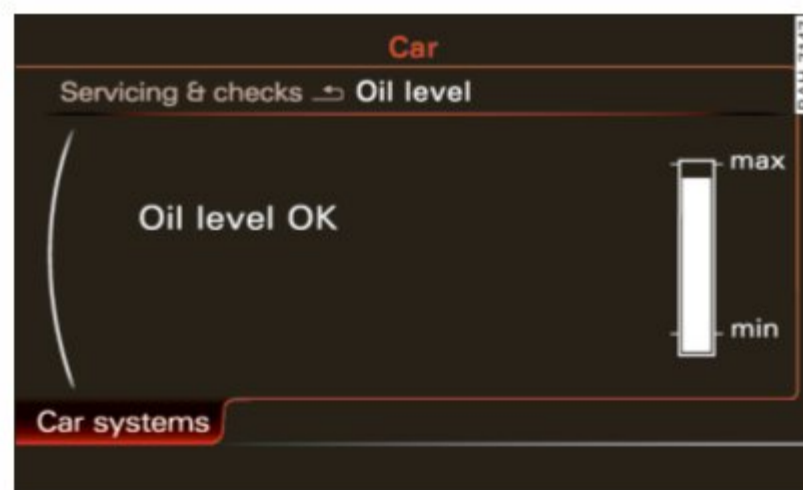

Fig. 201 Display: oil level indicator

- ▶ Park your vehicle on a level surface.
- ▶ Shut the engine off when it is warm.
- ▶ Switch only the ignition back on.
- ▶ Wait approximately two minutes.
- ▶ Select: **CAR** function button > **Car systems** control button > **Servicing & checks** > **Oil level**.
- ▶ Check the oil level in the display ⇒ fig. 201. Add engine oil if the bar of the oil level indicator is near “min” ⇒ page 237.

Depending on the way the vehicle is driven and the operating conditions, oil consumption can be up to 1/2 quart per 600 miles (0.5 liter per 1,000 km). Consumption may be higher within the first 3,000 miles (5,000 km). ▶

i Tips

The oil level indicator in the MMI Display is only an information display. If the oil level is low, a minimum oil warning appears in the instrument cluster. Add oil ⇒ *page 237*. If the hood has been opened, the current oil level is shown in the instrument cluster the next time the ignition is switched on.

Checking the engine oil level

Applies to vehicles: with oil dipstick

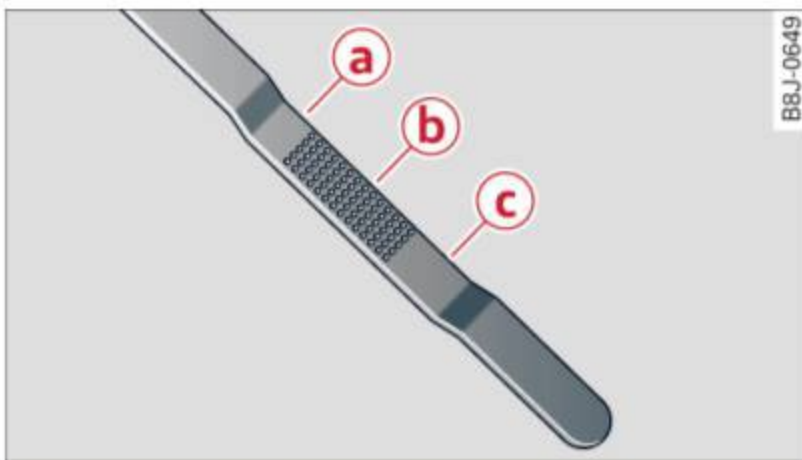

Fig. 202 Oil dipstick: marking fields

Before you check anything in the engine compartment, **always read and heed all WARNINGS** ⇒ *page 231*.

Determining the oil level

- ▶ Park your vehicle on a level surface.
- ▶ Let the engine run in idle briefly while it is at operating temperature and then shut the engine off.
- ▶ Wait approximately two minutes.
- ▶ Remove the oil dipstick. Wipe off the oil dipstick with a clean cloth and insert it all the way in again.
- ▶ Remove the dipstick again and then read the oil level ⇒ *fig. 202*. Add engine oil if necessary ⇒ *page 237*.

Oil level in the **a** area

- ▶ Do not add any oil.

Oil level in the **b** area

- ▶ You may add oil. After adding oil, the level should be in the **a** area.

Oil level in the **c** area

- ▶ You must add oil. After adding oil, the level should be in the **a** area.

Depending on the way the vehicle is driven and the operating conditions, oil consumption can be up to 1/2 quart per 600 miles (0.5 liter per 1,000 km). Consumption may be higher within the first 3,000 miles (5,000 km). Because of this, the engine oil level must be checked regularly. It would be best to check each time you refuel your vehicle and before long drives.

Adding engine oil



Fig. 203 Engine compartment: cover on the engine oil filler neck

Before you check anything in the engine compartment, **always read and heed all WARNINGS** ⇒  *in Working in the engine compartment on page 231*.

- ▶ Shut the engine off.
- ▶ Unscrew the cap  to the engine oil filling hole ⇒ *fig. 203*, ⇒ *page 233*.
- ▶ Carefully top off with 0.5 quarts (0.5 liters) of the appropriate oil ⇒ *page 234*.
- ▶ Check the oil level again after two minutes ⇒ *page 236, Checking the engine oil level* or ⇒ *page 237, Checking the engine oil level*.
- ▶ Top off the oil again, if necessary.
- ▶ Screw the cap back on the filling hole.

WARNING

- While topping off, the oil must not come in contact with hot engine parts - fire hazard!

- The oil filler cap must be properly secured to prevent oil from being sprayed on the hot engine and exhaust system when the engine is running - fire hazard!
- If your skin has come in contact with the engine oil, you must subsequently cleanse it thoroughly.

Note

- Check the oil level. If the message **Please reduce oil level** appears, contact your authorized Audi dealer or other qualified workshop to have excess oil extracted if necessary.
- **Audi does not recommend the use of oil additives. They may damage the engine and adversely affect your New Vehicle Warranty.**

For the sake of the environment

- Under no circumstances can the oil come in contact with the sewage network or the soil.
- Observe and follow legal regulations when disposing of empty oil containers.

Changing the engine oil

We recommend that have your oil changed by an authorized Audi dealer or a qualified service station.

Before you check anything in the engine compartment, **always read and heed all WARNINGS** ⇒  in *Working in the engine compartment on page 231.*

The engine oil must be changed according to the intervals specified in your Warranty & Maintenance booklet. This is very important because the lubricating properties of oil diminish gradually during normal vehicle use.

Under some circumstances the engine oil should be changed more frequently. Change oil more often if you drive mostly short distances, operate the vehicle in dusty areas or under predominantly stop-and-go traffic conditions, or have your vehicle where tempera-

tures remain below freezing for extended periods.

Detergent additives in the oil will make fresh oil look dark after the engine has been running for a short time. This is normal and is not a reason to change the oil more often than recommended.

Because of the problem of proper disposal, along with the special tools and necessary expertise required, we strongly recommend that you have your oil changed by an authorized **Audi dealer** or a qualified service station.

If you choose to change your oil yourself, please note the following important information:

WARNING

To reduce the risk of personal injury if you must change the engine oil in your vehicle yourself:

- Wear eye protection.
- To reduce the risk of burns from hot engine oil, let the engine cool down to the touch.
- When removing the oil drain plug with your fingers, stay as far away as possible. Always keep your forearm parallel to the ground to help prevent hot oil from running down your arm.
- Drain the oil into a container designed for this purpose, one large enough to hold at least the total amount of oil in your engine.
- Engine oil is poisonous. Keep it well out of the reach of children.
- Continuous contact with used engine oil is harmful to your skin. Always protect your skin by washing oil off thoroughly with soap and water.

Note

Never mix oil additives with your engine oil. These additives can damage your engine and adversely affect your Audi Limited New Vehicle Warranty.

**For the sake of the environment**

- Before changing your oil, first make sure you know where you can properly dispose of the used oil.
- Always dispose of used engine oil properly. Do not dump it on garden soil, wooded areas, into open streams or down sewage drains.
- Recycle used engine oil by taking it to a used engine oil collection facility in your area, or contact a service station.

Engine cooling system

Coolant

The engine coolant performs two functions: it keeps the engine from overheating and it protects the engine from freezing in the winter.

The cooling system is sealed and generally requires little attention.

The cooling system has been filled at the factory with a permanent coolant which does not need to be changed. The coolant consists of a mixture of specially conditioned water and the manufacturer's glycol-based coolant additive G13 antifreeze with anticorrosion additives (50% for USA models; 60% for Canadian models). This mixture both assures the necessary frost protection and protects metal components in the engine's cooling system from corrosion and scaling. It also raises the boiling point of the coolant.

Do not reduce the concentration of the coolant in the summer by adding plain water. **The proportion of coolant additive must be at least 50% but not more than 60%** to maintain antifreeze protection and cooling efficiency. If the coolant frost protection is too low, the coolant could freeze and damage the vehicle heating and engine cooling system.

For year-round driving, antifreeze is added at the factory for temperatures down to:

- - 31 °F (- 35 °C) USA
- - 40 °F (- 40 °C) Canada.

If you must add coolant, use a mixture of water and coolant additive. Mixing the coolant additive with distilled water is recommended.

**WARNING**

Before you check anything in the engine compartment, always read and heed all WARNINGS ⇒ *in Working in the engine compartment on page 231.*

**Note**

- Before winter sets in, have the coolant checked to see if the coolant additive in your vehicle is sufficient to meet the climate conditions. This is especially important if you live in a region where the winter is extremely cold. If necessary, increase the proportion of coolant additive to 60%.
- When adding coolant additive to your cooling system, remember:
 - We recommend using only coolant additive G12++ or G13 for your vehicle. This coolant additive is available at authorized Audi dealers. Other types of antifreeze can significantly reduce corrosion protection. The resulting corrosion can cause a loss of coolant and serious engine damage.
 - Do not add any type of radiator leak sealant to your vehicle's engine coolant. Adding radiator repair fluid may adversely affect the function and performance of your cooling system and could result in damage not covered by your New Vehicle Limited Warranty.

Checking the engine coolant level

The engine coolant level can be checked with a quick glance.



Fig. 204 Engine compartment: cover on the coolant expansion tank

Before you check anything in the engine compartment, **always read and heed all WARNINGS** ⇒ ⚠ in *Working in the engine compartment* on page 231.

Park your vehicle on a level surface.

- ▶ Switch off the ignition.
- ▶ Read the engine coolant level from the coolant expansion tank ⇒ *fig. 204*, ⇒ *page 233*. With a cold engine, the coolant level should be between the “min” and “max” markings. When the engine is warm, the level may be slightly above the “max” marking.

The location of the coolant expansion tank can be seen in the engine compartment illustration ⇒ *page 233*.

To obtain an accurate reading, the engine must be switched off.

The expansion tank in your vehicle is equipped with an electric coolant level sensor.

When the coolant level is too low, the warning light in the Auto-Check System ⇒ *page 16* will illuminate until you add coolant and the level has been restored to normal. Even though there is an electric coolant level sensor, we still recommend you check the coolant level from time to time.

Coolant loss

Coolant loss may indicate a **leak** in the cooling system. In the event of coolant loss, the cool-

ing system should be inspected immediately by your authorized Audi dealer. It is not enough merely to add coolant.

In a **sealed** system, losses can occur only if the boiling point of the coolant is exceeded as a result of overheating.

⚠ WARNING

The cooling system is under pressure and can get very hot. Reduce the risk of scalding from hot coolant by following these steps.

- Turn off the engine and allow it to cool down.
- Protect your face, hands and arms from escaping fluid and steam by covering the cap with a large, thick rag.
- Turn the cap slowly and very carefully in a counter-clockwise direction while applying light, downward pressure on the top of the cap.
- To avoid being burned, do not spill anti-freeze or coolant on the exhaust system or hot engine parts. Under certain conditions, the ethylene glycol in engine coolant can catch fire.

⚠ Note

Do not add any type of radiator leak sealant to your vehicle's engine coolant. Adding radiator repair fluid may adversely affect the function and performance of your cooling system and could result in damage not covered by your New Vehicle Limited Warranty.

Adding coolant

Be very careful when adding engine coolant.

Before you check anything in the engine compartment, **always read and heed all WARNINGS** ⇒ ⚠ in *Working in the engine compartment* on page 231.

- ▶ Turn off the engine.
- ▶ Let the engine cool down.

- ▶ Place a thick rag over the coolant expansion tank ⇒ *page 240, fig. 204* and **carefully** twist the cap counter-clockwise ⇒ .
- ▶ Add coolant mixed in the correct ratio ⇒ *page 239, Coolant*.
- ▶ Twist the cap on again *tightly*.

Replacement engine coolant must conform to exact specifications ⇒ *page 239, Coolant*.

We recommend using only coolant additive G12++, G13 or in an emergency G12+. Do **not** use a different additive. In an emergency use plain water until you can get the correct additive and can restore the correct ratio. This should be done as soon as possible.

If you have lost a considerable amount of coolant, then you should add cold antifreeze and cold water only when the engine is cold.

Always use *new* engine coolant when refilling.

Do not fill coolant above the "MAX" mark. Excess coolant will be forced out through the pressure relief valve in the cap when the engine becomes hot.

WARNING

- The cooling system is under pressure and can get very hot. Reduce the risk of scalding from hot coolant by following these steps.
 - Turn off the engine and allow it to cool down.
 - Protect your face, hands and arms from escaping fluid and steam by covering the cap with a large, thick rag.
 - Turn the cap slowly and very carefully in a counter-clockwise direction while applying light, downward pressure on the top of the cap.
 - To avoid being burned, do not spill antifreeze or coolant on the exhaust system or hot engine parts. Under certain conditions, the ethylene glycol in engine coolant can catch fire.
- Antifreeze is poisonous. Always store antifreeze in its original container and well out of the reach of children.

- If you drain the coolant, it must be caught and safely stored in a proper container clearly marked "poison".

Note

- Coolant pollutes the environment and could cause an engine fire. Excess coolant will be forced out through the pressure relief valve in the cap when the engine becomes hot.
- If, in an emergency, only water can be added, the correct ratio between water and antifreeze ⇒ *page 239* must be restored as soon as possible.

For the sake of the environment

Drained coolant should not be reused. Always dispose of used coolant while observing all environmental regulations.

Radiator fan

The radiator fan switches on automatically by itself.

The radiator fan is driven by the engine via the V-belt. The viscous clutch regulates the speed of the fan according to the temperature of the coolant.

An auxiliary electric radiator fan* switches on and off depending on coolant temperature and other vehicle operating conditions.

After you switch the engine off, the auxiliary fan can continue running for up to 10 minutes - even with the ignition off. It can even switch on again later by itself ⇒ , if

- the temperature of the engine coolant rises due to the heat build-up from the engine in the engine compartment, or
- the engine compartment heats up because the vehicle is parked in intense sunlight.

WARNING

- To reduce the risk of personal injury never touch the radiator fan.

- The auxiliary electric fan is temperature controlled and can switch on suddenly even when the engine is not running.
- The auxiliary radiator fan switches on automatically when the engine coolant reaches a certain temperature and will continue to run until the coolant temperature drops.

Brake fluid

Checking brake fluid level

The brake fluid level can be checked with a quick glance.



Fig. 205 Engine compartment: cover on the brake fluid reservoir

Before you check anything in the engine compartment, **always read and heed all WARNINGS** ⇒  in *Working in the engine compartment* on page 231.

- ▶ Read the brake fluid level from the brake fluid reservoir ⇒ *fig. 205*, ⇒ *page 233*. The brake fluid level must be between the “MIN” and “MAX” markings.

The location of the brake fluid reservoir can be seen in the engine compartment illustration ⇒ *page 233*.

The fluid level may drop *slightly* after some time due to the automatic adjustment of the brake pads. This is not cause for alarm.

If the brake fluid level falls *considerably* below the “MIN” mark, the brake warning/indicator light **BRAKE** (U.S. models)/ (Canadian models) will come on ⇒ *page 14*. Do not continue to operate the vehicle. The complete brake system should be thoroughly checked

by an authorized Audi dealer or other qualified facility and the cause corrected. If the brake fluid level is too low, the brake warning/indicator light will illuminate. Contact an authorized Audi dealer **immediately**.

Changing brake fluid

Have the brake fluid changed by an experienced technician.

Brake fluid absorbs moisture from the air. If the water content in the brake fluid is too high, corrosion in the brake system may result after a period of time. The boiling point of the brake fluid will also decrease considerably and decrease braking performance.

Therefore, the brake fluid must be changed **every two years**. Always use new brake fluid which conforms to Federal Motor Vehicle Standard “FMVSS 116 DOT 4”.

The brake fluid reservoir can be difficult to reach, therefore, we recommend that you have the brake fluid changed by your authorized **Audi dealer**. Your dealer has the correct tools, the right brake fluid and the know-how to do this for you.

WARNING

- Brake fluid is poisonous. It must be stored only in the closed original container out of the reach of children!
- Brake failure can result from old or inappropriate brake fluid. Observe these precautions:
 - Use only brake fluid that meets SAE specification J 1703 and conforms to Federal Motor Vehicle Standard 116. Always check with your authorized Audi dealer to make sure you are using the correct brake fluid. The correct type of brake fluid is also indicated on the brake fluid reservoir.
 - The brake fluid must be new. Heavy use of the brakes can cause a vapor lock if the brake fluid is left in the system too

long. This can seriously affect the efficiency of the brakes as well as your safety. This could result in an accident.

Note

Brake fluid will damage the paint of your vehicle.

For the sake of the environment

Because of the problem of proper disposal of brake fluid as well as the special tools required and the necessary expertise, we recommend that you have the brake fluid changed by your authorized Audi dealer.

Battery

General information

Under **normal** operating conditions, the battery in your Audi does not need any maintenance. With *high* outside temperatures or long daily drives we recommend that you have the electrolyte level checked by a service facility. The electrolyte level should also be checked each time the battery is charged ⇒ *page 245*.

Have the battery checked when you take your vehicle in for service. You are well advised to replace a battery that is older than 5 years.

With certain types of airbag deployment, the battery is disconnected from the vehicle electrical system for safety reasons ⇒  *in Repair, care and disposal of the airbags on page 167*.

Disconnecting the battery terminals

Some vehicle functions (power window regulators, for example) are lost if the battery terminals are disconnected. These functions have to be relearned after the battery terminals are connected again. To prevent this, the battery should only be disconnected from the vehicle electrical system when absolutely necessary for repairs.

Vehicles not driven for long periods

If you do not drive your vehicle over a period of several days or weeks, electrical components are gradually cut back or switched off. This reduces energy consumption and maintains starting capability over a longer period ⇒ *page 204*. Some of the convenience functions may not operate, such as the interior lights or the power seat adjustment. The convenience functions will be available again when you switch on the ignition and start the engine.

Winter operation

During the winter months, battery capacity tends to decrease as temperatures drop. This is because more power is also consumed while starting, and the headlights, rear window defogger, etc., are used more often.

Avoid unnecessary power consumption, particularly in city traffic or when traveling only short distances. Let your authorized Audi dealer check the capacity of the vehicle battery before winter sets in ⇒ *page 245*. A well charged battery will not only prevent starting problems when the weather is cold, but will also last longer.

Tips

If your vehicle is left standing for several weeks at extremely low temperatures, the vehicle battery should be removed and stored where it will not freeze. This will prevent it from being damaged and having to be replaced.





Working on the battery

Be especially careful when working on or near the battery.

The battery is located in the luggage compartment under the floor. Before you check anything in the luggage compartment, **read and heed all WARNINGS** ⇒ .

Always heed the **safety warnings**, when working on the vehicle battery or the vehicle electrical system to prevent injury.

The following **WARNINGS** are very important when working on the battery:

Always heed the following WARNING SYMBOLS and safety precautions when working on the battery.	
	Always wear eye protection.
	Battery acid contains sulfuric acid. Always wear gloves and eye protection.
	No - sparks - flames - smoking.
	When a battery is charged, it produces hydrogen gas which is explosive and could cause personal injury.
	Always keep the battery well out of reach of children.

WARNING

Whenever working on the battery or on the electrical system, there is the risk of injury, accident and even fire. Read and heed the following **WARNINGS**:

- Always wear eye protection. Do not let battery acid or any lead particles get on your skin or clothing. Shield your eyes. Explosive gases can cause blindness or other injury.
- Battery acid contains sulfuric acid. Sulfuric acid can cause blindness and severe burns.
- Always wear gloves and eye protection. Do not tilt the battery because acid could leak out of the ventilation openings.
- If you get battery acid in your eyes or on your skin, immediately rinse with cold water for several minutes and get medical attention.
- If you should ingest any battery acid, seek medical attention immediately.
- Do not expose the battery to an open flame, electric sparks or an open light.
- Do not smoke.

- Do not interchange the positive and negative cables.
- When working on the battery, be sure not to short-circuit the terminals with tools or other metal objects. This would cause the battery to heat up very quickly, which could lead to damage or explosion and personal injury.
- When a battery is charged, it produces hydrogen gas which is explosive and could cause personal injury.
- Always keep the battery well out of the reach of children.
- Before work is done on the electrical system, disconnect the negative ground cable.
- Before performing any work on the electrical system, switch off the engine and ignition as well as any electrical equipment. The negative cable on the battery must be disconnected. If you are just going to replace a light bulb, then it is enough to switch off the lights.
- Before disconnecting the battery, switch off the anti-theft alarm system! Otherwise you will set off the alarm.
- When disconnecting the battery, first disconnect the negative cable and then the positive cable.
- Before reconnecting the battery, make sure all electrical consumers are switched off. Reconnect the positive cable first and then the negative cable. Never interchange the cables - this could start a fire!
- Never charge a frozen or a thawed-out battery. It could explode! If a battery has frozen, then it must be replaced. A discharged battery can freeze over at 32 °F (0 °C).
- Make sure the vent hose is always attached to the opening on the side of the battery.
- Never use batteries which are damaged. There is the danger of an explosion! Always replace a damaged battery.

WARNING

California Proposition 65 Warning:

- Battery posts, terminals and related accessories contain lead and lead compounds, chemicals known to the State of California to cause cancer and reproductive problems. Wash hands after handling.

Note

- Do not disconnect the vehicle battery when the ignition is on or when the engine is running, otherwise, you will damage electronic components in the electrical system.
- If your vehicle is going to stand for a long period of time without being driven, protect the battery from “freezing”, otherwise it will be damaged and will then have to be replaced.

Battery charging

Starting the engine requires a well charged battery.

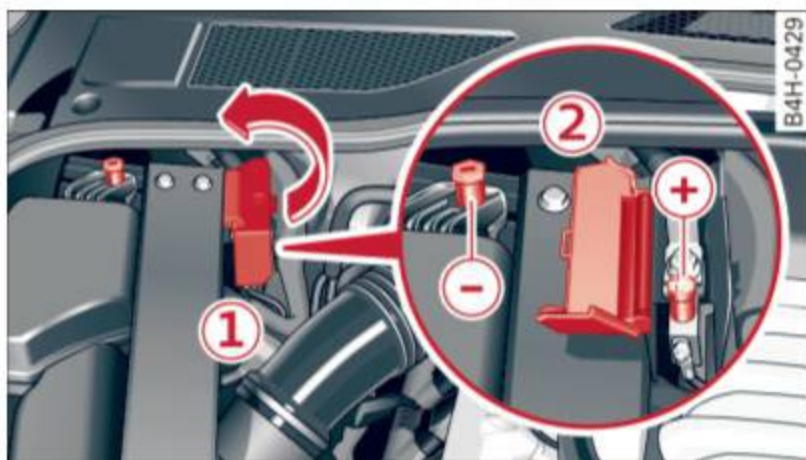





Fig. 206 Engine compartment: connectors for a charger and jump start cables

Always read and heed all **WARNINGS** below ⇒  and ⇒  in *Working on the battery* on page 244.

- ▶ Switch off the ignition and all electrical consumers.
- ▶ Make sure the area is well ventilated when you charge the battery.
- ▶ Open the engine hood ⇒ page 231.
- ▶ Remove the cover **1** by pressing on the arrow ⇒ fig. 206.

- ▶ Open the cover **2** on the positive terminal.
- ▶ Connect the charger connectors according to the instructions to the **jump start bolts**. (Bolts under the red cover = “positive”, Bolts with hex head = “negative”).
- ▶ Only now plug the mains lead for the charging equipment into the wall outlet and turn it on ⇒ .
- ▶ **Make sure the charging rate is not over 30 amps/14.8 Volt.**
- ▶ When the battery is fully charged: Turn the charging equipment off and remove the mains lead from the wall outlet.
- ▶ Now remove the clamps for the charging equipment.
- ▶ Close the red cover on the positive pole.
- ▶ Close the hood ⇒ page 232.

A discharged battery can **freeze** at temperatures of only 32 F° (0 °C). Allow a frozen battery to thaw completely before attempting to charge it ⇒ . However, we recommend not using a thawed battery again because the battery casing can be cracked due to ice formation and can leak battery acid.

Battery charging (Maximum charging rate of 30 amps/14.8 Volt)

When charging at *low* voltages (e.g. with a **trickle charger**), the battery cables do not have to be disconnected first. The battery caps should *not* be opened when charging a battery.

It is not necessary to remove the battery from the luggage compartment, and it is also not necessary to disconnect the cables.

Fast charging the battery (charging rate above 14.8 Volts)

For technical reasons do not use a battery charger that uses voltage greater than 14.8 Volts to charge your vehicle's battery.

WARNING

- Charging a battery can be dangerous.
- Always follow the operating instructions provided by the battery charger manufacturer when charging your battery.

- Never charge a frozen battery. It may explode because of gas trapped in the ice. Allow a frozen battery to thaw out first.
- Do not reuse batteries which were frozen. The battery housing may have cracked and weakened when the battery froze.
- Charge the battery in a well ventilated area. Keep away from open flame or electrical spark. Do not smoke. Hydrogen gas generated by the battery is explosive.
- To reduce the danger of explosion, never connect or disconnect charger cables while the charger is operating.
- Fast charging a battery is dangerous and should only be attempted by a competent technician with the proper equipment.
- Battery acid that may spill during charging should be washed off with a solution of warm water and baking soda to neutralize the acid.

Note

Never use a fast charger as a booster to start the engine. This will seriously damage sensitive electronic components, such as control units, relays, radio, etc., as well as the battery charger.

Battery replacement

The new battery must have the same specifications and dimensions as the original equipment battery.

Intelligent energy management in your vehicle is responsible for distributing the electrical energy throughout your vehicle ⇒ *page 204*. The intelligent energy management system will keep the engine battery charged better than vehicles without this system. To make sure the additional electrical energy is available once again after you have changed the battery, we recommend that you install batteries of the same type and manufacture only (the same as those installed at the time your vehicle was delivered). Specific-

cations are listed on the battery housing. Your authorized dealer must code the battery in the energy management system to enable you to use the energy management functions correctly after replacing the battery.

The new battery must have the same capacity, voltage (12 volts), amperage, construction and plug sealing.

When installing the battery, make sure the ignition and all electrical consumers are switched off.

Note

- Make sure the ventilation hose on the side of the battery is connected, otherwise fumes or battery acid can leak out.
- Vehicles with the Start-Stop-System* are equipped with a special cycle-proof AGM battery. Installing a different type of battery can cause problems in the vehicle electrical system. When replacing the vehicle battery, always install one with the same specifications as the original battery.
- Battery mounts and clamps must always be secured correctly.
- Read and follow the warnings under ⇒ *page 243, Working on the battery* before performing any work on the battery.

For the sake of the environment

Because of the problem of proper disposal of a battery, we recommend your authorized Audi dealer change the battery for you. Batteries contain sulfuric acid and lead and must always be disposed of properly in compliance with all environmental regulations. Disposing of vehicle batteries improperly is very dangerous to the environment.

Windshield/headlight washer container



Fig. 207 Engine compartment: cover on the windshield washer fluid reservoir

The washer fluid container is marked with the symbol  on its cap ⇒ *fig. 207*, ⇒ *page 233*.

- ▶ Before you check anything in the engine compartment, **always read and heed all WARNINGS** ⇒  in *Working in the engine compartment on page 231*.
- ▶ Lift the filler cap tongue to add washer fluid. You can fill the container to the top.
- ▶ Press the cap back onto the filler neck after filling the container.

You can find the reservoir **capacity** in the table in ⇒ *page 290*.

Clean water should be used when filling up. If possible, use soft water to prevent scaling on washer jets. Always add a glass cleaner solution (with frost protection in the winter).

Note

Do not mix engine coolant antifreeze or any other additives to fill up the windshield washer reservoir.

Tires and wheels

Tires

General notes

Tires may be the least appreciated and most abused parts of a motor vehicle.

Tires may be the least appreciated and most abused parts of a motor vehicle. Tires are, however, one of the most important parts of a vehicle, particularly considering the comparatively small patch of rubber on each tire that assures that all-important contact between you, your vehicle and the road.

Maintaining the correct tire pressure, making sure that your vehicle and its tires do not have to carry more weight than they can safely handle, avoiding damage from road hazards and regularly inspecting tires for damage including cuts, slashes irregular wear and overall condition are the most important things that you can do to help avoid sudden tire failure including tread separation and blowouts.

Avoiding damage

If you have to drive over a curb or similar obstacle, drive very slowly and as close as possible at a right angle to the curb.

Always keep chemicals including grease, oil, gasoline and brake fluid off the tires.

Inspect the tires regularly for damage (cuts, cracks or blisters, etc.). Remove any foreign bodies embedded in the treads.

Storing tires

Mark tires when you remove them to indicate the direction of rotation. This ensures you to be able to mount them correctly when you re-install them.

When removed, the wheels or tires should be stored in a cool, dry and preferably dark place.

Store tires in a vertical position if they are not mounted on rims, in a horizontal position if they are mounted on rims.

New tires

New tires have to be broken in ⇒ .

The tread depth of new tires may vary, according to the type and make of tire and the tread pattern.

Hidden damage

Damage to tires and rims is often not readily visible. If you notice unusual vibration or the vehicle pulls to one side, this may indicate that one of the tires has been damaged. The tires must be checked immediately by an authorized Audi dealer or qualified workshop.

Unidirectional tires

A unidirectional tire can be identified by arrows on the sidewall, that point in the direction the tire is designed to rotate. You must follow the specified direction of rotation. This is necessary so that these tires can develop their optimum characteristics regarding grip, road noise, wear and hydroplaning resistance. For more information ⇒ *page 277*.



WARNING

New tires or tires that are old, worn or damaged cannot provide maximum control and braking ability.

- New tires tend to be slippery and must be broken in. To reduce the risk of losing control, a collision and serious personal injuries, drive with special care for the first 350 miles (560 km).
- Driving with worn or damaged tires can lead to loss of control, sudden tire failure, including a blowout and sudden deflation, crashes and serious personal injuries. Have worn or damaged tires replaced immediately.
- Tires age even if they are not being used and can fail suddenly, especially at high speeds. Tires that are more than 6 years old can only be used in an emergency and then with special care and at low speed.

- Never mount used tires on your vehicle if you are not sure of their “previous history.” Old used tires may have been damaged even though the damage cannot be seen that can lead to sudden tire failure and loss of vehicle control.
- If you notice unusual vibration or if the vehicle pulls to one side when driving, always stop as soon as it is safe to do so and check the wheels and tires for damage.

Note

Please note that summer and winter tires are designed for the conditions that are

typical in those seasons. Audi recommends using winter tires during the winter months. Low temperatures significantly decrease the elasticity of summer tires, which affects traction and braking ability. If summer tires are used in very cold temperatures, cracks can form on the tread bars, resulting in permanent tire damage that can cause loud driving noise and unbalanced tires. Audi is not responsible for this type of damage.

Glossary of tire and loading terminology

Accessory weight

means the combined weight (in excess of those standard items which may be replaced) of automatic transmission, power steering, power brakes, power windows, power seats, radio, and heater, to the extent that these items are available as factory-installed equipment (whether installed or not).

Aspect ratio

means the ratio of the height to the width of the tire in percent. Numbers of 55 or lower indicate a low sidewall for improved steering response and better overall handling on dry pavement.

Bead

means the part of the tire that is made of steel wires, wrapped or reinforced by ply cords and that is shaped to fit the rim.

Bead separation

means a breakdown of the bond between components in the bead.

Cord

means the strands forming the plies in the tire.

Cold tire inflation pressure

means the tire pressure recommended by the vehicle manufacturer for a tire of a designated size that has not been driven for more than a couple of miles (kilometers) at low speeds in the three hour period before the tire pressure is measured or adjusted.

Curb weight

means the weight of a motor vehicle with standard equipment including the maximum capacity of fuel, oil, and coolant, air conditioning and additional weight of optional equipment.

Extra load tire

means a tire design to operate at higher loads and at higher inflation pressures than the corresponding standard tire. Extra load tires may be identified as “XL”, “xl”, “EXTRA LOAD”, or “RF” on the sidewall.

Gross Axle Weight Rating (“GAWR”)

means the load-carrying capacity of a single axle system, measured at the tire-ground interfaces.

Gross Vehicle Weight Rating (“GVWR”)

means the maximum total loaded weight of the vehicle. ▶

Groove

means the space between two adjacent tread ribs.

Load rating (code)

means the maximum load that a tire is rated to carry for a given inflation pressure. You may not find this information on all tires because it is not required by law.

Maximum load rating

means the load rating for a tire at the maximum permissible inflation pressure for that tire.

Maximum loaded vehicle weight

means the sum of:

- (a) Curb weight
- (b) Accessory weight
- (c) Vehicle capacity weight, and
- (d) Production options weight

Maximum (permissible) inflation pressure

means the maximum cold inflation pressure to which a tire may be inflated. Also called “maximum inflation pressure.”

Normal occupant weight

means 150 lbs. (68 kilograms) times the number of occupants seated in the vehicle up to the total seating capacity of your vehicle.

Occupant distribution

means distribution of occupants in a vehicle.

Outer diameter

means the overall diameter of an inflated new tire.

Overall width

means the linear distance between the exteriors of the sidewalls of an inflated tire, including elevations due to labeling, decorations, or protective bands or ribs.

Ply

means a layer of rubber-coated parallel cords.

Production options weight

means the combined weight of those installed regular production options weighing over 5 lbs. (2.3 kg) in excess of those standard items which they replace, not previously considered in curb weight or accessory weight, including heavy duty brakes, ride levelers, roof rack, heavy duty battery, and special trim.

Radial ply tire

means a pneumatic tire in which the ply cords that extend to the beads are laid at substantially 90 degrees to the centerline of the tread.

Recommended inflation pressure

see ⇒ *page 249, Cold tire inflation pressure.*

Reinforced tire

means a tire design to operate at higher loads and at higher inflation pressures than the corresponding standard tire. Reinforced tires may be identified as “XL”, “xl”, “EXTRA LOAD”, or “RF” on the sidewall.

Rim

means a metal support for a tire or a tire and tube assembly upon which the tire beads are seated.

Rim diameter

means nominal diameter of the bead seat. If you change your wheel size, you will have to purchase new tires to match the new rim diameter.

Rim size designation

means rim diameter and width.

Rim width

means nominal distance between rim flanges.

Sidewall

means that portion of a tire between the tread and bead. ►

Speed rating (letter code)

means the speed at which a tire is designed to be driven for extended periods of time. The ratings range from 93 mph (150 km/h) to 186 mph (298 km/h) ⇒ *page 260*. You may not find this information on all tires because it is not required by law.

The speed rating letter code, where applicable, is molded on the tire sidewall and indicates the maximum permissible road speeds ⇒  in *Winter tires on page 264*.

Tire pressure monitoring system*

means a system that detects when one or more of a vehicle's tires are underinflated and illuminates a low tire pressure warning tell-tale.

Tread

means that portion of a tire that comes into contact with the road.

Tread separation

means pulling away of the tread from the tire carcass.

Treadwear indicators (TWI)

means the projections within the principal grooves designed to give a visual indication of the degrees of wear of the tread. See ⇒ *page 258, Tread Wear Indicator (TWI)* for more information on measuring tire wear.

Uniform Tire Quality Grading

is a tire information system developed by the United States National Highway Traffic Safety Administration (NHTSA) that is designed to help buyers make relative comparisons among tires. The UTQG is not a safety rating and not a guarantee that a tire will last for a prescribed number of miles (kilometers) or perform in a certain way. It simply gives tire buyers additional information to combine with other con-

siderations, such as price, brand loyalty and dealer recommendations. Under UTQG, tires are graded by the tire manufacturers in three areas: treadwear, traction, and temperature resistance. The UTQG information on the tires, molded into the sidewalls.

U.S. DOT Tire Identification Number (TIN)

This is the tire's "serial number" It begins with the letters "DOT" and indicates that the tire meets all federal standards. The next two numbers or letters indicate the plant where it was manufactured, and the last four numbers represent the week and year of manufacture. For example,

DOT ... 2213 ...

means that the tire was produced in the 22nd week of 2013. The other numbers are marketing codes that may or may not be used by the tire manufacturer. This information is used to contact consumers if a tire defect requires a recall.

Vehicle capacity weight

means the rated cargo and luggage load plus 150 lbs. (68 kilograms) times the vehicle's total seating capacity as listed on the label located on the driver's side B-pillar.

Vehicle maximum load on the tire

means that load on an individual tire that is determined by distributing to each axle its share of the maximum loaded vehicle weight and dividing by two.

Vehicle normal load on the tire

means that load on an individual tire that is determined by distributing to each axle its share of the curb weight, accessory weight, and normal occupant weight (distributed in accordance with table below ⇒ *page 252*) and dividing by two. ▶

Occupant loading and distribution for vehicle normal load for various designated seating capacities

Designated seating capacity, number of occupants	Vehicle normal load, number of occupants	Occupant distribution in a normally loaded vehicle
4	2	2 in front
5	3	2 in front, 1 in back seat

Cold tire inflation pressure

Tire pressure affects the overall handling, performance and safety of a vehicle.

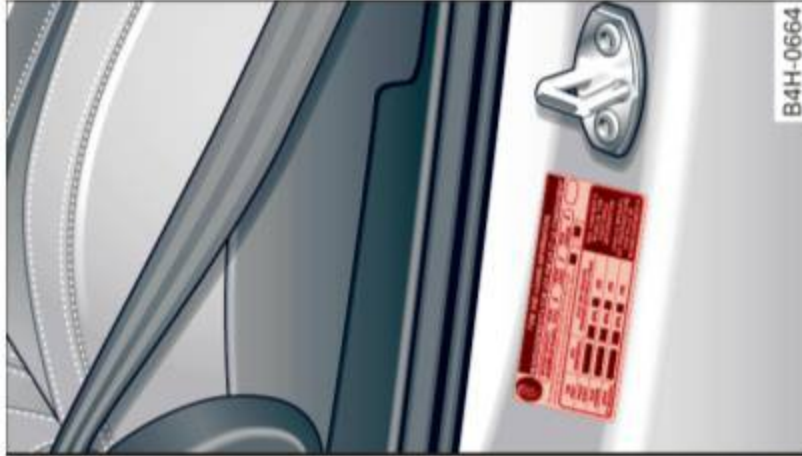

Fig. 208 Tire pressure label: located on driver's side B-pillar

Tire pressure generally refers to the amount of air in a tire that it needs it to do its job and safely carry the combined load of the entire vehicle and its contents. Tire pressure is measured in kilopascals (kPa), the international measuring unit and in pounds per square inch (PSI). Tire pressure is based in part on the vehicle's design and load limit – the greatest amount of weight that the vehicle can carry safely and the tire size. The proper tire pressure is frequently referred to as the “recommended cold tire inflation pressure.” Air in the tires expands when the tire heats up because of internal friction when it flexes in use. The tire pressure is higher when the tire has warmed up than when it is “cold.” It is the inflation pressure in a “cold” tire that counts. Therefore, you should never let air out of a warm tire to match “cold tire inflation pressure” recommendations. The tires would then be underinflated and could fail suddenly.

Maintaining proper tire pressure is one of the most important things you can do to help avoid sudden tire failure. Underinflated tires are a major cause of sudden tire failure. Keeping tires at the right pressure is also impor-

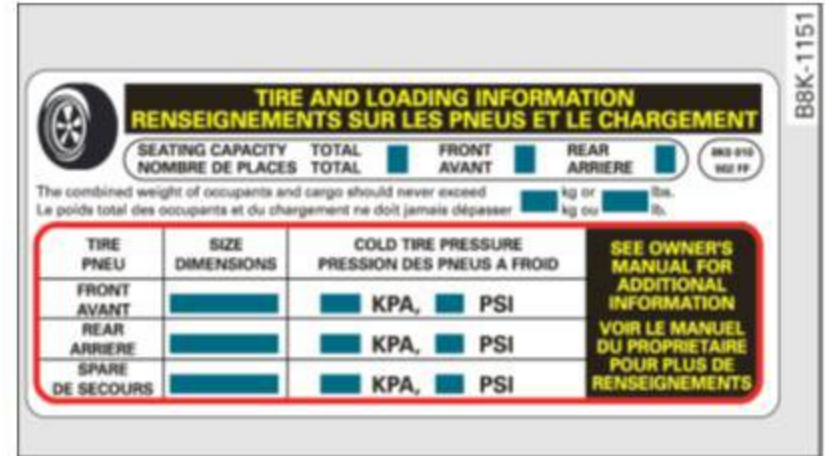

Fig. 209 Tire pressure label

tant for safe and responsive vehicle handling, traction, braking and load carrying. **Tire pressures are particularly important when the vehicle is being driven at higher speeds, and then especially when heavily loaded even within the permissible load-carrying capacities approved for your vehicle.**

The recommended tire pressures for your Audi depend on the kind of tires on your vehicle and the number of passengers and/or amount of luggage you will be transporting.

The tire pressure label is located on the driver's side B-pillar. The tire pressure label lists the recommended cold tire inflation pressures for the vehicle at its maximum capacity weight and tires that were on your vehicle at the time it was manufactured.

If you wish to improve comfort when operating the vehicle at normal load (up to 2*/3 occupants), you can adjust tire pressures to those specified for normal vehicle load. Before operating the vehicle at maximum load, you must increase the tire pressures to those specified for maximum vehicle load → ⚠.

Bear in mind that the tire pressure monitoring system* can only monitor the tire pressures you have stored. The system does not recognize the load condition of your vehicle.

The effectiveness of the tire pressure monitoring system* will be impaired if you store normal load pressures but then operate the vehicle at its maximum load ⇒ ⚠.

See the illustration ⇒ *fig. 208* for the location of the label on driver's side B-pillar (color of the actual label and exact location on the vehicle will vary slightly).

Note that the following table is accurate at the time of going to press and is subject to change. In the event of discrepancies, the tire pressure label is located on the driver's side B-pillar always takes precedence.

The table below lists the recommended cold tire inflation pressures for the Audi model covered by your Owner's Literature at the vehicle's capacity weight and the tire sizes installed on the respective models as original equipment, or as a factory option.

Model/Engine	Tire designation	Tire pressure							
		normal load condition				full load condition			
		front ^{a)}		rear ^{a)}		front		rear	
		PSI	kPA	PSI	kPA	PSI	kPA	PSI	kPA
A8/A8 L: 3.0 liter 6-cylinder	235/55 R18 104H	35	240	32	220	36	250	38	260
	255/45 R19 104H	35	240	32	220	36	250	38	260
	265/40 R20 104H	35	240	32	220	36	250	38	260
	265/40 R20 104Y	33	230	32	220	33	230	35	240
	275/35 R21 103Y XL	35	240	32	220	36	250	35	240
A8/A8 L: 4.0 liter 8-cylinder	235/55 R18 104H	35	240	32	220	38	260	38	260
	255/45 R19 104H	35	240	32	220	38	260	38	260
	265/40 R20 104H	35	240	32	220	38	260	38	260
	265/40 R20 104Y	33	230	32	220	35	240	35	240
	275/35 R21 103Y XL	35	240	32	220	38	260	38	260
A8 L: 6.3 liter 12-cylinder	265/40 R20 104Y	35	240	32	220	36	250	35	240
	255/45 R19 104H	36	250	32	220	39	270	38	260
	265/40 R20 104H	36	250	32	220	39	270	38	260
	275/35 R21 103Y XL	35	240	32	220	36	250	35	240
S8: 4.0 liter 8-cylinder	265/40 R20 104Y	36	250	32	220	39	270	38	260
	265/35 R21 101Y	39	270	35	240	44	300	42	290
	275/35 R21 103Y XL	39	270	35	240	44	300	42	290

XL = reinforced or extra load tire. It may also appear as xl, EXTRA LOAD, or RF on the tire sidewall.

^{a)} normal load condition ⇒ *page 252*.

The correct tire pressure for the *spare wheel* is located on a label on the driver's side B-pillar.

Because technical changes may be made to vehicle equipment during the model year, always compare the tire size designation on the

tire pressure label on your vehicle with the tires on your vehicle. Make sure that the tire size information on the vehicle label is the same as the size of the tires on the vehicle. This is especially important if the vehicle belongs to someone else or you bought the

vehicle with different rims/tires or you bought the vehicle as a previously owned vehicle.

Remember, your safety and that of your passengers also depends on making sure that load limits are not exceeded. Vehicle load includes everybody and everything in and on the vehicle. These load limits are technically referred to as the vehicle's Gross Vehicle Weight Rating ("GVWR"). The Gross Axle Weight Rating ("GAWR") is the maximum load that can be applied at each of the vehicle's two axles. The Gross Vehicle Weight Rating and the Gross Axle Weight Rating are listed on the safety compliance sticker label located on the driver's side B-pillar. The tire pressure label on your Audi lists the maximum combined weight of all of the occupants and luggage or other cargo that the vehicle can carry. For the location of the tire pressure label ⇒ *fig. 208*.

WARNING

Overloading a vehicle can cause loss of vehicle control, a crash or other accident, serious personal injury, and even death.

- Carrying more weight than your vehicle was designed to carry will prevent the vehicle from handling properly and increase the risk of a loss of vehicle control.
- The brakes on a vehicle that has been overloaded may not be able to stop the vehicle within a safe distance.
- Tires on a vehicle that has been overloaded can fail suddenly causing loss of control and a crash.
- Always make sure that the total load being transported – including the weight of a trailer hitch and the tongue weight of a loaded trailer – does not make the vehicle heavier than the vehicle's Gross Vehicle Weight Rating.

WARNING

- Incorrect tire pressures and/or underinflation can lead to a serious or fatal accident.

- Incorrect tire pressures and/or underinflation cause increased tire wear and can affect the handling of the vehicle.
- Incorrect tire pressures and/or underinflation can also lead to sudden tire failure, including a blowout and sudden deflation, causing loss of vehicle control.

Checking tire pressure

The correct tire pressure for the tires originally installed on your vehicle is listed on the tire pressure label located on driver's side B-pillar.

The recommended tire pressures are on the tire pressure label and in the table ⇒ *page 252, Cold tire inflation pressure*. This means that the pressure must be checked and adjusted when the tire has not been driven for more than a couple of miles (kilometers) at low speeds during the previous three hours. Air in the tires expands when the tire heats up as a result of internal friction as it flexes in use. The tire pressure is higher when the tire has warmed up than when it is "cold."

It is the inflation pressure in a "cold" tire that counts. Therefore, you should never let air out of a warm tire to match "Cold tire inflation pressure" recommendations ⇒ *page 252*. The tires would then be underinflated and could fail suddenly.

The tire pressure label on your Audi lists the recommended cold tire inflation pressures at maximum capacity for the new, original equipment tires that were on your vehicle at the time it was manufactured. For the location of the label ⇒ *page 252, fig. 208*.

Most tires lose air naturally over time. They can also lose some air if you drive over a pothole or hit a curb while parking. It is usually not possible to see whether the radial tires used today are underinflated just by looking at them.

Therefore, be sure to check tire pressures at least once a month and always before going on a long trip. Make sure to take the number

of people and the amount of luggage into account when adjusting tire pressure for a trip – even one that you would not consider to be “long.” See ⇒ *page 256, Tires and vehicle load limits* for more important information.

Always use an accurate tire pressure gauge when checking and adjusting inflation pressures. Check all of the tires and be sure not to forget the spare tire. If the pressure in any tire is too high when the tire is “cold,” let air out of the tire slowly with the edge of the tire gauge and keep checking the pressure until you reach the pressure that is correct for the load (passengers and luggage) and kind of driving you plan to do.

If the pressure in any tire is too low, note the difference between the pressure in the cold tire and the pressure you need and add the air that you need to reach the correct pressure for the vehicle load (passengers and luggage) for the tires on your vehicle as listed on the on your vehicle and in this manual and the kind of driving you plan to do.

Never exceed the maximum inflation pressure listed on the tire sidewall for any reason.

Remember that the vehicle manufacturer, not the tire manufacturer, determines the correct tire pressure for the tires on your vehicle.

It is important to check the tire pressure when the tires are cold.

- Read the required tire pressure from the tire pressure label. The tire pressure label is located on the driver's side B-pillar.
- Turn the valve stem cap counter-clockwise to remove it from the tire valve.
- Place the air pressure gauge on the valve.
- The tire pressures should only be checked and adjusted when the tires are cold. The slightly raised pressures of warm tires must not be reduced.
- Adjust the tire pressure to the load you are carrying.
- Reinstall the valve stem cap on the valve.

When should I check the tire pressure?

The correct tire pressure is especially important at high speeds. The pressure should therefore be checked at least once a month and always before starting a journey. Do not forget to check the tire pressure for the spare wheel ⇒ *page 271*.

When should I adjust the tire pressures?

Adjust the tire pressure to the load you are carrying. After changing a wheel **or** replacing wheels you have to adjust the tire pressures on all wheels. In addition, you must then store the new tire pressures in the tire pressure monitoring system* ⇒ *page 266*.

WARNING

Incorrect tire pressures and/or underinflation can lead sudden tire failure, loss of control, collision, serious personal injury or even death.

- When the warning symbol  appears in the instrument cluster, stop and inspect the tires.
- Incorrect tire pressure and/or underinflation can cause increased tire wear and can affect the handling of the vehicle and stopping ability.
- Incorrect tire pressures and/or underinflation can also lead to sudden tire failure, including a blowout and sudden deflation, causing loss of vehicle control.
- The driver is responsible for the correct tire pressures for all tires on the vehicle. The applicable pressure values are located on a sticker on the driver's side B-pillar.
- Only when all tires on the vehicle are filled to the correct pressure, the tire pressure monitoring* system can work correctly.
- The use of incorrect tire pressure values can lead to accidents or other damage. Therefore it is essential that the driver observe the specified tire pressure values for the tires and the correct pressures for

the function of the tire pressure monitoring system*.

- Always inflate tires to the recommended and correct tire pressure before driving off.
- Driving with underinflated tires bend more, letting them get too hot resulting in tread separation, sudden tire failure and loss of control.
- Excessive speed and/overloading can cause heat build-up, sudden tire failure and loss of control.
- If the tire pressure is too low or too high, the tires will wear prematurely and the vehicle will not handle well.
- If the tire is not flat and you do not have to change a wheel immediately, drive at reduced speed to the nearest service station to check the tire pressure and add air as required.

Note

Driving without valve stem caps can cause damage to the tire valves. To prevent this, always make sure that factory installed valve stem caps on all wheels are securely mounted on the valve.

For the sake of the environment

Underinflated tires will also increase the fuel consumption.

Tires and vehicle load limits

There are limits to the amount of load or weight that any vehicle and any tire can carry. A vehicle that is overloaded will not handle well and is more difficult to stop. Overloading can not only lead to loss of vehicle control, but can also damage important parts of the vehicle and can lead to sudden tire failure, including a blowout and sudden deflation that can cause the vehicle to crash.

Your safety and that of your passengers also depends on making sure that load limits are not exceeded. Vehicle load includes everybody and everything in and on the vehicle. These

load limits are technically referred to as the vehicle's **Gross Vehicle Weight Rating** ("GVWR").

The "GVWR" includes the weight of the basic vehicle, all factory installed accessories, a full tank of fuel, oil, coolant and other fluids plus maximum load. The maximum load includes the number of passengers that the vehicle is intended to carry ("seating capacity") with an assumed weight of 150 lbs (68 kg) for each passenger at a designated seating position and the total weight of any luggage in the vehicle. If you tow a trailer, the weight of the trailer hitch and the tongue weight of the loaded trailer must be included as part of the vehicle load.

The **Gross Axle Weight Rating** ("GAWR") is the maximum load that can be applied at each of the vehicle's two axles.

The Gross Vehicle Weight Rating and the Gross Axle Weight Rating are listed on the safety compliance sticker label located on the driver's side B-pillar. Your Audi has 5 seating positions, 2 in the front and 3 in the rear for total seating capacity of 5. Vehicles with power individual rear seats* have 4 seating positions, 2 in the front and 2 in the rear for total seating capacity of 4. Each seating position has a safety belt ⇒ *page 145, Safety belts*.

The fact that there is an upper limit to your vehicle's Gross Vehicle Weight Rating means that the total weight of whatever is being carried in the vehicle (including the weight of a trailer hitch and the tongue weight of the loaded trailer) is limited. The more passengers in the vehicle or passengers who are heavier than the standard weights assumed mean that less weight can be carried as luggage.

The tire pressure label on your Audi also lists the maximum combined weight of all of the occupants and luggage or other cargo that the vehicle can carry. For the location of the label ⇒ *page 252, fig. 208*.

! WARNING

Overloading a vehicle can cause loss of vehicle control, a crash or other accident, serious personal injury, and even death.

- Carrying more weight than your vehicle was designed to carry will prevent the vehicle from handling properly and increase the risk of the loss of vehicle control.
- The brakes on a vehicle that has been overloaded may not be able to stop the vehicle within a safe distance.
- Tires on a vehicle that has been overloaded can fail suddenly, including a blowout and sudden deflation, causing loss of control and a crash.
- Always make sure that the total load being transported – including the weight of a trailer hitch and the tongue weight of a loaded trailer – does not make the vehicle heavier than the vehicle’s Gross Vehicle Weight Rating.

Determining correct load limit

Use the example below to calculate the total weight of the passengers and luggage or other things that you plan to transport so that you can make sure that your vehicle will not be overloaded.

Steps for Determining Correct Load Limit

1. Locate the statement “THE COMBINED WEIGHT OF OCCUPANTS AND CARGO SHOULD NEVER EXCEED XXX KG OR XXX LBS” on your vehicle’s placard (tire inflation pressure label) ⇒ *page 252, fig. 208.*
2. Determine the combined weight of the driver and passengers that will be riding in your vehicle.
3. Subtract the combined weight of the driver and passengers from “XXX” kilograms or “XXX” pounds shown on the sticker ⇒ *page 252, fig. 208.*
4. The resulting figure equals the available amount of cargo and luggage load capacity. For example, if the “XXX” amount equals 1400 lbs. and there will be five 150 lbs. passengers in your vehicle, the amount of available cargo and luggage load capacity is 650 lbs. ($1400 - 750 (5 \times 150) = 650$ lbs.)
5. Determine the combined weight of luggage and cargo being loaded on the vehicle. That weight may not safely exceed the available cargo and luggage load capacity calculated in Step 4.
6. If your vehicle will be towing a trailer, load from your trailer will be transferred to your

vehicle. Consult this manual to determine how this reduces the available cargo and luggage load capacity of your vehicle.

- ▶ Check the tire sidewall (⇒ *page 259, fig. 212*) to determine the designated load rating for a specific tire.

Tire service life

The service life of tires depends on a lot of different things including proper installation and balancing, correct tire pressure and driving style.

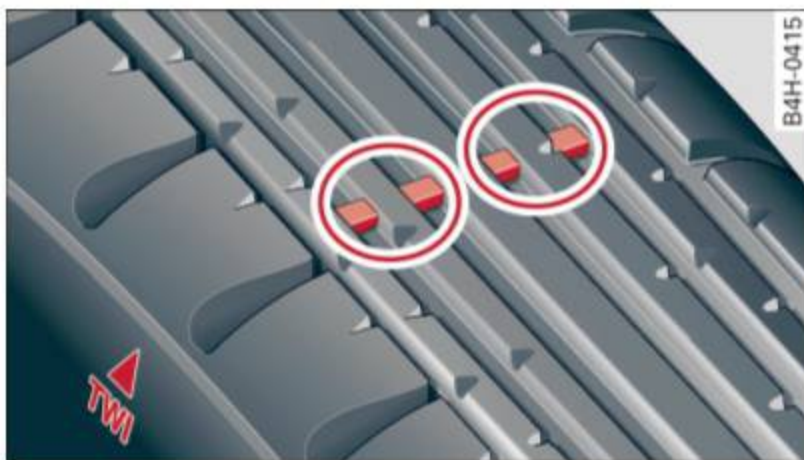

Fig. 210 Tire tread: tread wear indicators (TWI)

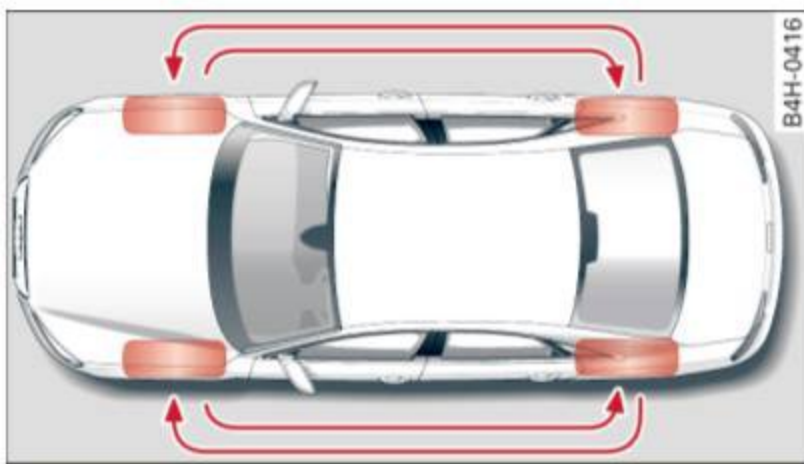

Fig. 211 Rotating tires for more even wear

Tread Wear Indicator (TWI)

The original tires on your vehicle have 1/16 inch (1.6 mm) high “wear indicators” ⇒ *fig. 210* running across the tread. Depending on the make, there will be six to eight of them evenly placed around the tire. Marks on the tire sidewall (for example “TWI” or other

symbols) indicate the positions of the tread wear indicators. Worn tires must be replaced. Different figures may apply in other countries ⇒ ⚠.

Tire pressure

Incorrect tire pressure causes premature wear and can cause sudden tire blow-out. For this reason, tire pressure must be checked at least once a month ⇒ *page 254*.

Driving style

Driving fast around curves, heavy acceleration and hard braking increase tire wear.

Rotating tires for more even wear

For all four tires on your vehicle to have the same service life, we recommend that the front and rear tires are rotated according to the tire manufacturer's suggested tire rotation intervals. Please remember the following:

- Tire rotation intervals may differ from the vehicle service intervals outlined in your Warranty & Maintenance booklet.
- The longer one tire is used in one location on the vehicle, the more it wears at certain points; therefore, we recommend that you follow the tire manufacturer's suggested tire rotation intervals.
- Vehicles with front-wheel drive experience more tread wear on the front wheels compared to all-wheel drive (quattro).
- Please rotate tires as shown ⇒ *fig. 211*.
- Extra care must be taken when rotating direction-specific tires ⇒ *page 277*.

Wheel balancing

The wheels on new vehicles are balanced. However, various situations during everyday driving can cause them to become unbalanced, resulting in vibrations you can usually feel through the steering wheel.

Unbalanced wheels must be rebalanced to avoid excessive wear on steering, suspension and tires. A wheel must also be rebalanced when a new tire is installed. ▶

Incorrect wheel alignment

Incorrect wheel alignment can cause excessive tire wear, impairing the safety of the vehicle. If tires show excessive wear, have the wheel alignment checked by an authorized Audi dealer or qualified workshop.

All Wheel Drive

Vehicles with quattro must always have tires of the same size, construction and tread type. For details see ⇒ page 204.

WARNING

- Sudden tire failure can lead to loss of control, a crash and serious personal injury!
- Never drive a vehicle when the tread on any tire is worn down to the wear indicators.
 - Worn tires are a safety hazard, they do not grip well on wet roads and increase your risk of “hydroplaning” and loss of control.
 - Always keep chemicals that can cause tire damage, such as grease, oil, gasoline and brake fluid away from tires.
 - Tires age even if they are not being used and can fail suddenly, especially at high speeds. Tires that are more than 6 years old can only be used in an emergency and then with special care and at lower speeds.
 - Never mount used tires on your vehicle if you are not sure of their “previous history.” Old used tires may have been damaged even though the damage cannot be seen that can lead to sudden tire failure and loss of vehicle control.

New tires and replacing tires and wheels

New tires and wheels have to be broken in.

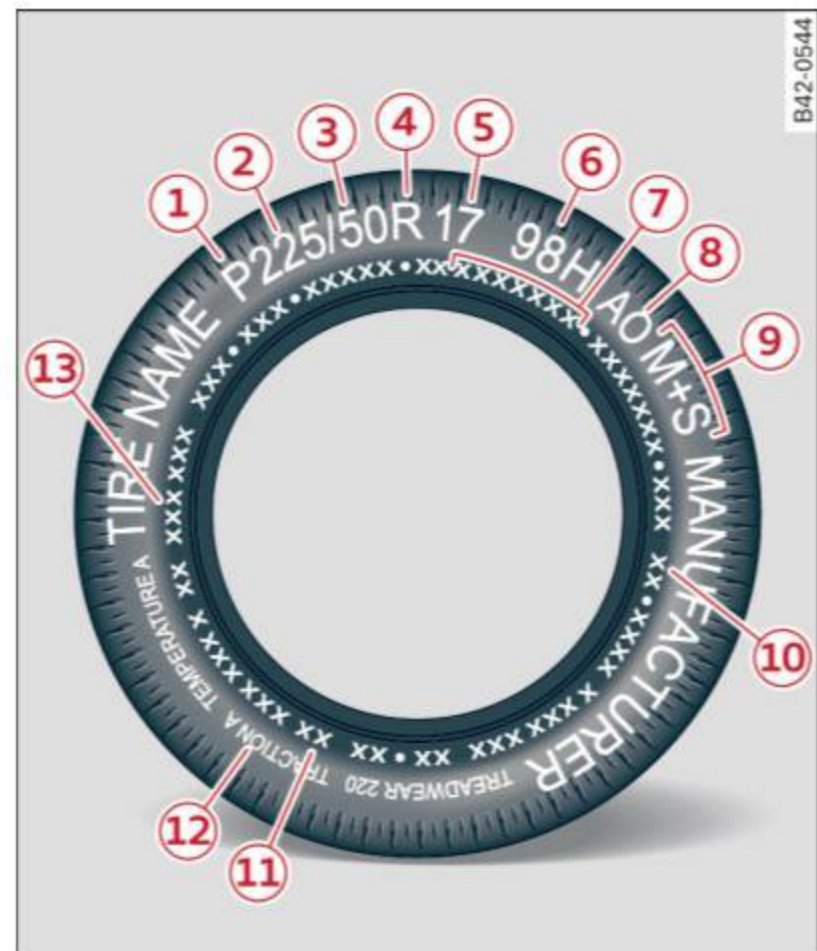



Fig. 212 Tire specification codes on the sidewall of a tire

No.	Description
①	Passenger car tire (where applicable)
②	Nominal width of tire in millimeters
③	Ratio of height to width (aspect ratio)
④	Radial
⑤	Rim diameter code
⑥	Load index and speed rating
⑦	U.S. DOT tire identification number
⑧	Audi Original tire
⑨	Sever snow conditions
⑩	Tire ply composition and materials used
⑪	Maximum load rating
⑫	Treadwear, traction and temperature grades
⑬	Maximum permissible inflation pressure

The tires and rims are essential parts of the vehicle's design. The tires and rims approved by Audi are specially matched to the characteristics of the vehicle and can make a major

contribution to good road holding and safe handling when in good condition and properly inflated ⇒ .

We recommend that all work on tires and wheels be performed by an authorized Audi dealer. They are familiar with recommended procedures and have the necessary special tools and spare parts as well as the proper facilities for disposing of the old tires.

Authorized Audi dealers have the necessary information about technical requirements for installing or changing tires and rims.

Replacing tires and wheels

Tires should be replaced at least in pairs and not individually (for example both front tires or both rear tires together).

Be sure to read and heed the information to the tire pressure monitoring system* ⇒ *page 266*.

Always buy replacement radial tires that have the same specifications as the tires approved for your vehicle by Audi. Replacement tires must always have the same load rating specification as the original equipment or approved optional tires listed in the table ⇒ *page 252*.

Audi-approved specification tires are specially matched to your vehicle and its load limits, and can contribute to the important roadholding, driving characteristics, and safety of the vehicle. The table (⇒ *page 252*) lists specifications of the tires approved for the Audi models covered by your Owner's Literature.

The tire pressure label located on driver's side B-pillar (⇒ *page 252, fig. 209*) lists the specifications of the original equipment tires installed on your vehicle at the time it was manufactured.

Federal law requires tire manufacturers to place standardized information on the sidewall of all tires ⇒ *fig. 212*. This information identifies and describes the fundamental characteristics, the quality grade of the tire and also provides a tire identification number

for safety standard certification and in case of a recall.

Tire specifications

Knowledge of tire specifications makes it easier to choose the correct tires. Radial tires have the tire specifications marked on the sidewall, for example:

255/45 R 19 104 H

This contains the following information:

- P** Indicates the tire is for passenger cars (where applicable)
- 255** Nominal tire width in mm of the tire from sidewall edge to sidewall edge. In general, the larger the number, the wider the tire
- 45** Height/width ratio in percent (aspect ratio)
- R** Tire construction: **Radial**
- 19** Rim diameter code (in inches)
- 104** Load rating code
- H** Speed rating letter code
- XL** (or "xl", "EXTRA LOAD" or "RF") Indicates that the tire is a "Reinforced" or an "Extra Load" tire
- M+S** (or "M/S") Indicates that the tire has some mud and snow capability

The tires could also have the information of direction of rotation ⇒ *page 248*.

Tire manufacturing date

The manufacturing date is also indicated on the tire sidewall (possibly only on the *inner* side of the wheel):

"DOT ... 2213..." means, for example, the tire was produced in the 22nd week of 2013.

Speed rating (letter code)

The speed rating letter code on the wheels indicates the maximum permissible road speeds ⇒  in *Winter tires on page 264*.

- P** up to 93 mph (150 km/h)
- Q** up to 99 mph (158 km/h)
- R** up to 106 mph (170 km/h)
- S** up to 110 mph (180 km/h)



- T up to 118 mph (190 km/h)
- U up to 124 mph (200 km/h)
- H up to 130 mph (210 km/h)
- V up to 149 mph (240 km/h)¹⁾
- Z over 149 mph (240 km/h)¹⁾
- W up to 168 mph (270 km/h)¹⁾
- Y up to 186 mph (298 km/h)¹⁾

Your vehicle is normally factory equipped with tires, which possess excellent driving characteristics and give your Audi optimum driving comfort. An electronic speed limiter ⇒ *page 30* will normally prevent your vehicle from going faster than the tire speed rating ⇒ .

U.S. DOT Tire Identification Number (TIN) and tire manufacture date

This is the tire's "serial number". It begins with the letters "DOT" and indicates that the tire meets all federal standards. The next two numbers or letters indicate the plant where it was manufactured, and the last four numbers represent the week and year of manufacture. For example, the numbers 2213 mean the tire was produced in the 22nd week of 2013. The other numbers are marketing codes that may or may not be used by the tire manufacturer. This information is used to contact consumers if a tire defect requires a recall.

Audi original tire

Tires with the identification "AO" or "RO" have been specially matched with your Audi. We recommend using only these tires because they meet the highest standards regarding safety and driving characteristics when used correctly. Your authorized Audi dealer will gladly provide you with more information.

Tire ply composition and materials used

The number of plies indicates the number of layers of rubber-coated fabric in the tire. In general, the greater the number of plies, the more weight a tire can support. Tire manufac-

turers also must indicate the materials in the tire, which include steel, nylon, polyester, and others.

Maximum Load Rating

This number indicates the maximum load in kilograms and pounds that can be carried by the tire.

Tire quality grading for treadwear, traction, and temperature resistance

Tread wear, traction and temperature grades ⇒ *page 262*.

Maximum Permissible Inflation Pressure

This number is the greatest amount of air pressure that should ever be put in the tire under normal driving conditions.



WARNING

- Using incorrect or unmatched tires and / or wheels or improper tire and wheel combinations can lead to loss of control, collision and serious personal injury.
- Always use tires, rims and wheel bolts that meet the specifications of original factory-installed tires or other combinations that have been specifically approved by the vehicle manufacturer.
- Tires age even if they are not being used and can fail suddenly, especially at high speeds. Tires that are more than 6 years old can only be used in an emergency and then with special care and at lower speeds.
- Never mount used tires on your vehicle if you are not sure of their "previous history." Old used tires may have been damaged even though the damage cannot be seen that can lead to sudden tire failure and loss of vehicle control.
- All four wheels must be fitted with radial tires of the same type, size (rolling circumference) and the same tread pattern.

¹⁾ For tires with a maximum speed capability over 149 mph (240 km/h), tire manufacturers sometimes use the letters "ZR."

Driving with different tires reduces vehicle handling and can lead to a loss of control.

- If the spare tire is not the same as the tires that are mounted on the vehicle - for example with winter tires - only use the spare tire for a short period of time and drive with extra care. Refit the normal road wheel as soon as safely possible.
- Never drive faster than the maximum speed for which the tires on your vehicle are rated because tires that are driven faster than their rated speed can fail suddenly.
- Overloading tires cause heat build-up, sudden tire failure, including a blowout and sudden deflation and loss of control.
- Temperature grades apply to tires that are properly inflated and not over or underinflated.
- For technical reasons it is not always possible to use wheels from other vehicles - in some cases not even wheels from the same vehicle model.
- If you install wheel trim discs on the vehicle wheels, make sure that the air flow to the brakes is not blocked. Reduced air-flow to the brakes can lead them to overheat, increasing stopping distances and causing a collision.
- Run flat tires may only be used on vehicles that were equipped with them at the factory. The vehicle must have a chassis designed for run flat tires. Incorrect use of run flat tires can lead to vehicle damage or accidents. Check with an authorized Audi dealer or tire specialist to see if your vehicle can be equipped with run flat tires. If run flat tires are used, they must be installed on all four wheels. Mixing tire types is not permitted.

Note

- For technical reasons, it is not generally possible to use the wheel rims from oth-

er vehicles. This can hold true for wheels of the same vehicle type.

- If the spare tire is different from the tires that you have mounted on your vehicle (for example winter tires or wide profile tires), then use the spare tire for a short period of time only and drive with extra care. Replace the flat tire with the tire matching the others on your vehicle as soon as possible.
- Never drive without the valve stem cap. The valves could get damaged.



For the sake of the environment

Dispose of old tires in accordance with the local requirements.

Uniform tire quality grading

- Tread wear
- Traction AA A B C
- Temperature A B C

Quality grades can be found where applicable on the tire side wall between tread shoulder and maximum section width ⇒ *page 259, fig. 212.*

For example: Tread wear **200**, Traction **AA**, Temperature **A**.

All passenger car tires must conform to Federal Safety Requirements in addition to these grades.

Tread wear

The *tread wear* grade is a comparative rating based on the wear rate of the tire when tested under controlled conditions on a specified government test course.

For example, a tire graded 150 would wear one and one half (1 1/2) times as well on the government course as a tire graded 100.

The relative performance of tires depends upon the actual conditions of their use, however, and may depart significantly from the norm due to variations in driving habits, service practices and differences in road characteristics and climate.

Traction

The *traction* grades, from highest to lowest, are AA, A, B and C. Those grades represent the tire's ability to stop on wet pavement as measured under controlled conditions on specified government test surfaces of asphalt and concrete. A tire marked C may have poor traction performance ⇒ ⚠.

Temperature

The *temperature* grades are A (the highest), B, and C, representing the tire's resistance to the generation of heat and its ability to dissipate heat when tested under controlled conditions on a specified indoor laboratory test wheel.

Sustained high temperature can cause the material of the tire to degenerate and reduce tire life, and excessive temperature can lead to sudden tire failure ⇒ ⚠.

The grade C corresponds to a level of performance which all passenger car tires must meet under the Federal Motor Vehicle Safety Standard No. 109. Grades B and A represent higher levels of performance on the laboratory test wheel than the minimum required by law.

⚠ WARNING

The traction grade assigned to this tire is based on straight-ahead braking traction tests, and does not include acceleration, cornering, hydroplaning or peak traction characteristics.

⚠ WARNING

The temperature grade for this tire is established for a tire that is properly inflated and not overloaded. Excessive speed, underinflation, or excessive loading, either separately or in combination, can cause heat buildup and possible tire failure.

Winter tires

Winter tires can improve vehicle handling on snow and ice. At temperatures below 45 °F (7 °C) we recommend changing to winter tires.

In some heavy snow areas, local governments may require true winter or “snow” tires, those with very deeply cut tread. These tires should only be used in pairs and be installed on all four wheels. Make sure you purchase snow tires that are the same size and construction type as the other tires on your vehicle.

If your vehicle is equipped with all-wheel drive*, this will improve traction during winter driving, even with the standard tires. However, we strongly recommend that you always equip all four wheels on your vehicle with correctly fitted winter tires or all-season tires, when winter road conditions are expected. This also improves the vehicle's braking performance and reduces stopping distances.

Summer tires provide less grip on ice and snow.

Winter tires (snow tires) must always be fitted on all four wheels.

Ask your authorized Audi dealer or qualified workshop for permitted **winter tire sizes**. Use only radial winter tires.

Winter tires lose their effectiveness when the tread is worn down to a depth of 0.157 inch (4 mm).

Only drive with winter tires under winter conditions. Summer tires handle better when there is no snow or ice on the roads and the temperature is above 45 °F (7 °C).

If you have a flat tire, see notes on spare wheel ⇒ *page 259*.

Please always remember that winter tires may have a lower speed rating than the tires originally installed on your vehicle at the time it was manufactured. Please see ⇒ *page 260, Speed rating (letter code)* for a listing of the speed rating letter codes and the maximum speed at which the tires can be driven. ▶

The speed rating letter code (⇒ page 251) is on the side wall of the tire ⇒ page 259.

WARNING

Winter tires have maximum speed limits that may be lower than your vehicle's maximum speed. Always know the maximum speed before driving off. Never drive faster than the speed permitted for your specific winter tires. This will cause damage to the tires leading to an accident and serious personal injury to you and your passengers.

WARNING

Driving faster than the maximum speed for which the winter tires on your vehicle were designed can cause tire failure including a blowout and sudden deflation, loss of control, crashes and serious personal injuries. Have worn or damaged tires replaced immediately.

- Winter tires have maximum speed rating that may be lower than your vehicle's maximum speed.
- Never drive faster than the speed for which the winter or other tires installed on your vehicle are rated.

WARNING

Always adjust your driving to the road and traffic conditions. Never let the good acceleration of the winter tires and all-wheel drive tempt you into taking extra risks. Always remember:

- When braking, an all-wheel drive vehicle handles in the same way as a front drive vehicle.
- Drive carefully and reduce your speed on icy and slippery roads, even winter tires cannot help under black ice conditions.

For the sake of the environment

Use summer tires when weather conditions permit. They are quieter, do not wear as quickly and reduce fuel consumption.

Snow chains

Snow chains may be fitted only to the front wheels, and only to certain tire sizes. Ask your authorized Audi dealer on which tire sizes snow chains can be used.

If you are going to use snow chains, then you must install them on the front wheels at least.

The snow chains must have low-profile links and must not be thicker than 0.4 inch (10,5 mm), including the lock.

Remove wheel center covers and trim discs before putting snow chains on your vehicle ⇒ . For safety reasons cover caps must then be fitted over the wheel bolts. These are available from authorized Audi dealers.

WARNING

Using the wrong snow chains for your vehicle or installing them incorrectly can increase the risk of loss of control leading to serious personal injury.

- Snow chains are available in different sizes. Always make sure to follow the instructions provided by the snow chain manufacturer.
- When driving with snow chains never drive faster than the speed permitted for your specific snow chains.
- Always observe local regulations.

Note

- Remove snow chains before driving on roads not covered with snow to avoid damaging tires and wearing the snow chains down unnecessarily.
- Snow chains, which come into direct contact with the wheel rim, can scratch or damage it. Therefore, make sure that the snow chains are suitably covered. Check the position of the snow chains after driving a few yards and correct if necessary. Follow the instructions from the snow chain manufacturer when doing so.
- If the Adaptive Air Suspension should malfunction, do not mount or use snow

chains because the vehicle will be extremely low. If you do drive with snow chains on while the vehicle is at this level, the snow chains might severely damage the wheelhouse and other parts of the vehicle.

Tips

Where snow chains are mandatory on certain roads, this normally also applies to vehicles with All Wheel Drive.

Wheel bolts

Wheel bolts must always be tightened to the correct torque.

The design of wheel bolts is matched to the factory installed rims. If different rims are fitted, the correct wheel bolts with the right length and correctly shaped bolt heads must be used. This ensures that wheels are fitted securely and that the brake system functions correctly.

In certain circumstances, you may not use wheel bolts from a different vehicle – even if it is the same model ⇒ *page 294*.

WARNING

Improperly tightened or maintained wheel bolts can become loose causing loss of control, a collision and serious personal injury.

- Always keep the wheel bolts and the threads in the wheel hubs clean so the wheel bolts can turn easily and be properly tightened.
- Never grease or oil the wheel bolts and the threads in the wheel hubs. They can become loose while driving if greased or oiled, even if tightened to the specified torque.
- Only use wheel bolts that belong to the rim being installed.
- Never use different wheels bolts on your vehicle.
- Always maintain the correct tightening torque for the wheel bolts to reduce the

risk of a wheel loss. If the tightening torque of the wheel bolts is too low, they can loosen and come out when the vehicle is moving. If the tightening torque is too high, the wheel bolts and threads can be damaged and the wheel can become loose.

Note

The specified torque for the wheel bolts is 90 ft lb (120 Nm) with a tolerance of $\pm 7,4$ ft lb (± 10 Nm). Torque wheel bolts diagonally. After changing a wheel, the torque must be checked as soon as possible with a torque wrench – preferably by an authorized Audi dealer or qualified workshop.

Low aspect ratio tires

Your Audi is factory-equipped with low aspect ratio tires. These tires have been thoroughly tested and been selected specifically for your model for their superb performance, road feel and handling under a variety of driving conditions. Ask your authorized Audi dealer for more details.

The low aspect ratio of these tires is indicated by a numeral of **55 or less** in the tire's size designation. The numeral represents the ratio of the tire's sidewall height in relation to its tread width expressed in percentage. Conventional tires have a height/width ratio of 60 or more.

The performance of low-aspect-ratio tires is particularly sensitive to improper inflation pressure. It is therefore important that low aspect ratio tires are inflated to the specified pressure and that the inflation pressure is regularly checked and maintained. Tire pressures should be checked at least once a month and always before a long trip ⇒ *page 254, Checking tire pressure*.

What you can do to avoid tire and rim damage

Low aspect ratio tires can be damaged more easily by impact with potholes, curbs, gullies ▶

or ridges on the road, particularly if the tire is underinflated.

In order to minimize the occurrence of impact damage to the tires of your vehicle, we recommend that you observe the following precautions:

- Always maintain recommended inflation pressures. Check your tire pressure every 2,000 miles (3,000 km) and add air if necessary.
- Drive carefully on roads with potholes, deep gullies or ridges. The impact from driving through or over such obstacles can damage your tires. Impact with a curb may also cause damage to your tires.
- After any impact, immediately inspect your tires or have them inspected by the nearest authorized Audi dealer. Replace a damaged tire as soon as possible.
- Inspect your tires every 2,000 miles (3,000 km) for damage and wear. Damage is not always easy to see. Damage can lead to loss of air and underinflation, which could eventually cause tire failure. If you believe that a tire may have been damaged, replace the tire as soon as possible.
- These tires may wear more quickly than others.
- Please also remember that, while these tires deliver responsive handling, they may ride less comfortably and make more noise than other choices.

Reduced performance in winter/cold season conditions

All tires are designed for certain purposes. The low aspect ratio, ultra high performance tires originally installed on your vehicle are intended for maximum dry and wet road performance and handling. They are not suitable for cold, snowy or icy weather conditions. If you drive under those circumstances, you should equip your vehicle with all-season or winter tires, which offer better traction under those conditions. We suggest you use the recommended snow or all-season tires specified for your vehicle, or their equivalent.

Refer to ⇒ *page 263* for more detailed information regarding winter tires.

Tire pressure monitoring system

(!) General notes

Applies to vehicles: with tire pressure monitoring system

Each tire, including the spare (if provided), should be checked monthly when cold and inflated to the inflation pressure recommended by the vehicle manufacturer on the vehicle placard or tire inflation pressure label. (If your vehicle has tires of a different size than the size indicated on the vehicle placard or tire inflation pressure label, you should determine the proper tire inflation pressure for those tires).

As an added safety feature, your vehicle has been equipped with a tire pressure monitoring system (TPMS) that illuminates a low tire pressure telltale when one or more of your tires is significantly under-inflated. Accordingly, when the low tire pressure telltale illuminates, you should stop and check your tires as soon as possible, and inflate them to the proper pressure. Driving on a significantly under-inflated tire causes the tire to overheat and can lead to tire failure. Under-inflation also reduces fuel efficiency and tire tread life, and may affect the vehicle's handling and stopping ability.

Please note that the TPMS is not a substitute for proper tire maintenance, and it is the driver's responsibility to maintain correct tire pressure, even if under-inflation has not reached the level to trigger illumination of the TPMS low tire pressure telltale.

Your vehicle has also been equipped with a TPMS malfunction indicator to indicate when the system is not operating properly. The TPMS malfunction indicator is combined with the low tire pressure telltale. When the system detects a malfunction, the telltale will flash for approximately one minute and then ►

remain continuously illuminated. This sequence will continue upon subsequent vehicle start-ups as long as the malfunction exists.

When the malfunction indicator is illuminated, the system may not be able to detect or signal low tire pressure as intended. TPMS malfunctions may occur for a variety of reasons, including the installation of replacement or alternate tires or wheels on the vehicle that prevent the TPMS from functioning properly. Always check the TPMS malfunction telltale after replacing one or more tires or wheels on your vehicle to ensure that the replacement or alternate tires and wheels allow the TPMS to continue to function properly.

Tire pressure indicator appears

Applies to vehicles: with tire pressure monitoring system

The tire pressure indicator in the instrument cluster informs you if the tire pressure is too low or if there is a system malfunction.



Fig. 213 Display: underinflation warning



Fig. 214 Display: System malfunction

Using the ABS sensors, the tire pressure monitoring system compares the tire tread circumference and vibration characteristics of the individual tires. If the pressure decreases in one or more tires, this is indicated in the instru-



ment cluster with a warning symbol  and a message ⇒ *fig. 213*.

The tire pressure monitoring system must be reset via MMI each time the pressures are adjusted (e. g. when switching between partial and full load pressure) or after changing or replacing a tire on your vehicle ⇒ *page 268*. The TPMS indicator only monitors the tire pressure that you have previously stored. You can find the recommended tire pressures for your vehicle on the label on driver's side B-pillar ⇒ *page 252*.

Tire tread circumference and vibration characteristics can change and cause a tire pressure warning if:

- the tire pressure in one or more tires is too low,
- the tire has structural damage,
- the tire pressure was changed, wheels rotated or replaced but the TPMS was not reset ⇒ *page 268*.

Warning symbols

 Loss of pressure in at least one tire ⇒ . Check the tire or tires and replace or repair if necessary. The indicator light  in the instrument cluster also illuminates ⇒ *page 11*. Check/correct the pressures of all four tires and reset TPMS via MMI.

TPMS (Tire Pressure Monitoring System) **Tire pressure! System malfunction.**

If **TPMS** appears after switching the ignition on or while driving ⇒ *fig. 214* and the indicator light  in the instrument cluster blinks for approximately one minute and then stays on, there is a system malfunction.

Attempt to store the correct tire pressure ⇒ *page 268*. If the indicator light does not turn off or if it turns on shortly thereafter, immediately drive your vehicle to an authorized Audi dealer or authorized repair facility to have the malfunction corrected. ▶

 **WARNING**

- If the tire pressure indicator appears in the instrument cluster display, one or more of your tires is significantly under-inflated. Reduce your speed immediately and avoid any hard steering or braking maneuvers. Stop as soon as possible and check the tires and their pressures. Inflate the tire pressure to the proper pressure as indicated on the vehicle's tire pressure label ⇒ *page 252*. Driving on a significantly under-inflated tire causes the tire to overheat and can lead to tire failure. Under-inflation also is likely to impair the vehicle's handling and stopping ability.
- The driver is responsible for maintaining the correct tire pressures. You must check the tire pressures regularly.
- Under certain conditions (such as a sporty driving style, winter conditions or unpaved roads), the pressure monitor indicator may be delayed.
- Ask your authorized Audi dealer if run-flat tires may be used on your vehicle. Your vehicle registration becomes invalid if you use these tires when not permitted. Damage to your vehicle or accidents could also result.

 **Tips**

- The tire pressure monitoring system stops working when there is an ESC/ABS malfunction.
- Using snow chains may result in a system malfunction.
- The tire pressure monitoring system on your Audi was developed using tires with the “AO” or “RO” identification on the tire sidewall ⇒ *page 259*. We recommend using these tires.

Reset tire pressure monitoring system

Applies to vehicles: with tire pressure monitoring system

If the tire pressure is adjusted, wheels are rotated or changed, the TPMS must be reset via MMI.

- ▶ Switch on the ignition.
- ▶ Select in the MMI: **CAR** function button > **Car systems** control button > **Servicing & checks** > **Tire pressure monitoring** > **Store tire pressures** > **Yes, store now**.

 **Tips**

Do not store the tire pressure if there are snow chains on the tire.

What do I do now?

Trunk escape handle

In case of an emergency, the rear lid can be opened from the inside using the trunk escape handle.



Fig. 215 Trunk escape handle: View from inside the closed trunk

To open rear lid

- ▶ Pull the handle down towards the bumper
⇒ fig. 215.

The trunk escape handle inside the rear lid is made of fluorescent material to glow in the dark.

WARNING

The trunk escape handle is to be used only in an emergency.

Tips

The emergency release lever should *never* be used as a handle for closing the rear lid.

Emergency warning triangle

Applies to vehicles: with emergency warning triangle

The warning triangle is located on the inside of the trunk lid.



Fig. 216 Trunk lid: Warning triangle

- ▶ To remove the warning triangle, press the retainer in the direction of the arrow
⇒ fig. 216 and fold the holder down.

The rear lid is only designed to hold the warning triangle offered by the original accessories program. If you would like to retrofit your vehicle with a warning triangle, please contact your authorized Audi dealer.

Vehicle tool kit

Vehicle tool kit and jack

The vehicle tool kit is located in the luggage compartment under the cargo floor cover.



Fig. 217 Luggage compartment: cargo floor cover folded upward

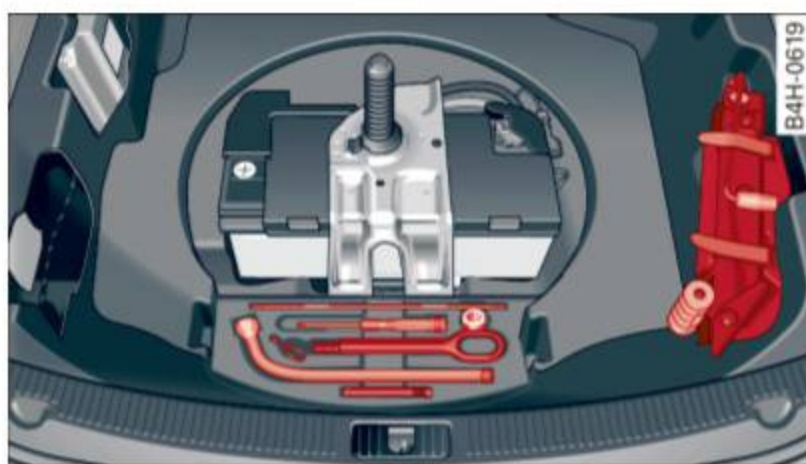

Fig. 218 Trunk lid: Vehicle tool kit

- ▶ Lift the cargo floor by the plastic handle.
- ▶ Hook the handle into the luggage compartment weather strip ⇒ *fig. 217*.
- ▶ Remove the spare wheel to reach the vehicle tool kit.
- ▶ Remove the foam piece.

The onboard tool kit includes:

- Hooks to remove the wheel covers* or wheel hub covers
- Plastic hook to remove wheel bolt covers*
- Wheel bolt wrench
- Alignment pin for changing wheels
- Screwdriver with reversible blade
- Towing loop
- Jack

Before storing the jack, make sure it is wound back down as far as it will go.

WARNING

Improper use of the vehicle jack can cause serious personal injuries.

- Never use the screw driver hex head to tighten wheel bolts, since the bolts cannot attain the necessary tightening torque if you use the hex head, potentially causing an accident.
- The factory-supplied jack is intended only for your vehicle model. Under no circumstances should it be used to lift heavy vehicles or other loads; you risk injuring yourself.
- Never start the engine when the vehicle is raised, which could cause an accident.
- Support the vehicle securely with appropriate stands if work is to be performed underneath the vehicle; otherwise, there is a potential risk for injury.
- Never use the jack supplied with your Audi on another vehicle, particularly on a heavier one. The jack is only suitable for use on the vehicle it came with.

Tips

- Some of the onboard items listed above are provided on certain models only or are optional extras.
- Before you can raise your vehicle using the jack, you must activate the jacking mode ⇒ *page 275*.

Space-saving spare tire (compact spare tire)*

Applies to vehicles: with space-saving spare tire

The spare tire/wheel is located in the luggage compartment under the cargo floor cover. It is intended for short-term use only.

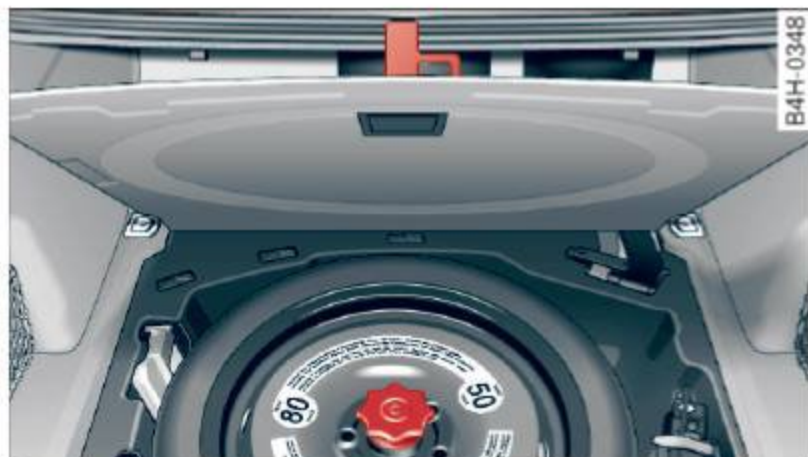

Fig. 219 Spare tire

Taking out the spare tire

- ▶ Lift the cargo floor by the plastic handle ⇒ *fig. 219*.
- ▶ Hook the handle into the luggage compartment weather strip.
- ▶ Turn the large screw ⇒ *fig. 219* counterclockwise.
- ▶ Take out the spare tire.
- ▶ Always store the vehicle tool kit, the jack* and the replaced tire in the luggage compartment ⇒ *page 141*.
- ▶ Unhook the cargo floor before closing the rear lid.

Using the spare tire (compact spare tire)

The compact spare tire is only intended for emergencies until you can reach a repair shop. Replace it as quickly as possible with a standard wheel and tire.

There are some restrictions on the use of the compact spare tire. The compact spare tire has been designed specifically for your type of vehicle. It must not be swapped with a compact spare tire from another type of vehicle.

Snow chains

For technical reasons, the use of snow chains on the compact spare tire is **not permitted**.

If you do have to drive with snow chains and a *front tire* fails, mount the spare wheel with

tire instead of a rear tire. Install the snow chains on the rear tire and use it to replace the defective front tire.

WARNING

- Never use the spare tire if it is damaged or if it is worn down to the tread wear indicators.
- If the spare tire is more than 6 years old, use it only in an emergency and with extreme caution and careful driving.
- The spare tire is intended only for temporary and short-term use. It should be replaced as soon as possible with the normal wheel and tire.
- After mounting the compact spare tire, the tire pressure must be checked as soon as possible. The tire pressure of the compact spare tire must be 4.2 bar; otherwise, you risk having an accident.
- Do not drive faster than 50 mph (80 km/h). You risk having an accident.
- Avoid full-throttle acceleration, heavy braking, and fast cornering. You risk having an accident.
- Never drive using more than one spare wheel and tire. You risk having an accident.
- Normal summer or winter tires must not be mounted on the compact spare wheel rim.
- For technical reasons, the use of tire chains on the spare tire is not permitted. If it is necessary to drive with tire chains, the spare wheel must be mounted on the front axle in the event of a flat in a rear tire. The newly available front wheel must then be installed in place of the rear wheel with the flat tire. Installing the tire chain before mounting the wheel and tire is recommended.
- Loose items in the passenger compartment can cause serious personal injury during hard braking or in an accident. Never store the inflatable spare tire or jack and tools in the passenger compartment.

Spare wheel

Applies to vehicles: with spare wheel

The spare wheel is stored in the wheel well underneath the floor panel in the luggage compartment.

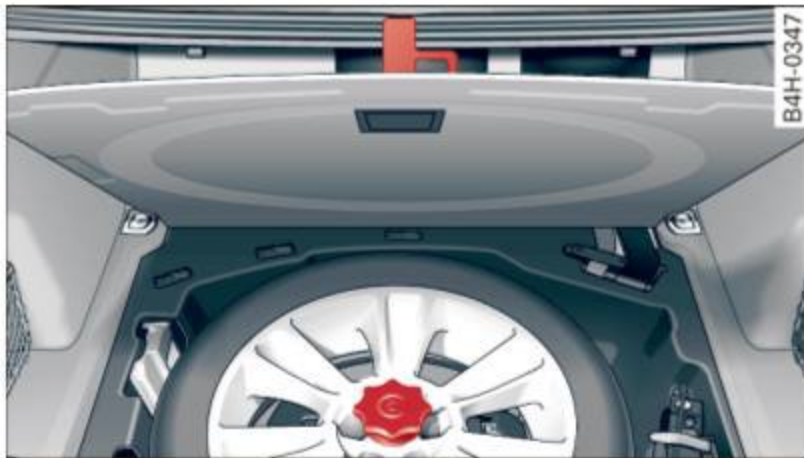

Fig. 220 Luggage compartment: spare wheel

Taking out the spare wheel

- ▶ Lift the cargo floor by the plastic handle ⇒ *fig. 220*.
- ▶ Hook the handle into the luggage compartment weather strip.
- ▶ Turn the large screw ⇒ *fig. 220* counter-clockwise.
- ▶ Take out the spare tire.
- ▶ Always store the vehicle tool kit, the jack* and the replaced tire in the luggage compartment ⇒ *page 141*.
- ▶ Unhook the cargo floor before closing the rear lid.

WARNING

Loose items in the passenger compartment can cause serious personal injury during hard braking or in an accident.

- Never store the spare wheel or jack and tools in the passenger compartment.





Tips

Check the inflation pressure of the spare tire periodically to keep the tire ready for use.

Changing a wheel

Before changing a wheel

Observe the following precautions for your own and your passenger's safety when changing a wheel.

- ▶ After you experience a tire failure, pull the car well away from moving traffic and try to reach **level** ground before you stop ⇒ .
- ▶ All passengers should **leave the car** and move to a safe location (for instance, behind the guardrail) ⇒ .
- ▶ Engage the **parking brake** to prevent your vehicle from rolling unintentionally ⇒ .
- ▶ Move **selector lever to position P** ⇒ .
- ▶ If you are towing a trailer, unhitch the trailer from your vehicle.
- ▶ Take the **jack** and the **spare tire** out of the luggage compartment ⇒ *page 270*, ⇒ *page 271*.

WARNING

You or your passengers could be injured while changing a wheel if you do not follow these safety precautions:

- If you have a flat tire, move a safe distance off the road. Turn off the engine, turn the emergency flashers on and use other warning devices to alert other motorists.
- Make sure that passengers wait in a safe place away from the vehicle and well away from the road and traffic.
- To help prevent the vehicle from moving suddenly and possibly slipping off the jack, always fully set the parking brake and block the wheel diagonally opposite the wheel being changed. When one front wheel is lifted off the ground, placing the Automatic Transmission in “P” (Park) will *not* prevent the vehicle from moving.
- Before you change a wheel, be sure the ground is level and firm. If necessary, use a sturdy board under the jack.

– Always store the vehicle tool kit, the jack and the replaced tire in the luggage compartment ⇒ *page 141*.

i Tips

Before changing the wheel, you must activate the jacking mode, so that the automatic controls for the Adaptive Air Suspension do not make it more difficult to lift the vehicle with the jack ⇒ *page 275*.

Changing a wheel

When you change a wheel, follow the sequence described below step-by-step and in exactly that order.

1. Activate the vehicle jack mode ⇒ *page 275*.
2. Remove the **decorative wheel cover***. For more details see also ⇒ *page 273, Decorative wheel covers* or ⇒ *page 274, Wheels with wheel bolt caps*.
3. Loosen the **wheel bolts** ⇒ *page 274*.
4. Locate the proper mounting point for the jack and align the jack below that point ⇒ *page 275*.
5. **Raise** the car with the jack ⇒ *page 275*.
6. Remove the **wheel with the flat tire** and then install **the spare** ⇒ *page 276*.
7. Tighten all wheel bolts lightly.
8. **Lower** the vehicle with the jack.
9. Use the wheel bolt wrench and **firmly** tighten all wheel bolts ⇒ *page 274*.
10. Replace the decorative **wheel cover***.
11. Deactivate the vehicle jack mode in the MMI: **CAR** function button > **Car systems** control button > **Servicing & checks** > **Air susp.: jack mode** > **Off**.

The vehicle jack mode switches off automatically at speeds above 10 km/h.

! WARNING

Always read and follow all WARNINGS and information ⇒ **!** in *Raising the vehicle on page 275* and ⇒ *page 277*.

After changing a wheel

A wheel change is not complete without the doing the following.

- ▶ Always store the vehicle tool kit, the jack* and the replaced tire in the luggage compartment ⇒ *page 141*.
- ▶ Check the **tire pressure** on the spare wheel immediately after mounting it.
- ▶ As soon as possible, have the **tightening torques** on all wheel bolts checked with a torque wrench. The correct tightening torque is 90 ft lb (120 Nm).
- ▶ Have the flat tire **replaced** as soon as possible.

i Tips

- If you notice that the wheel bolts are corroded and difficult to turn while changing a tire, they should be replaced before you check the tightening torque.
- Drive at reduced speed until you have the tightening torques checked.
- After changing a wheel, the tire pressure in all four tires must be checked/corrected and the tire pressure monitoring indicator must be stored in the MMI ⇒ *page 268*.

Decorative wheel covers

Applies to vehicles: with decorative wheel covers

The decorative wheel covers must be removed first to access the wheel bolts.

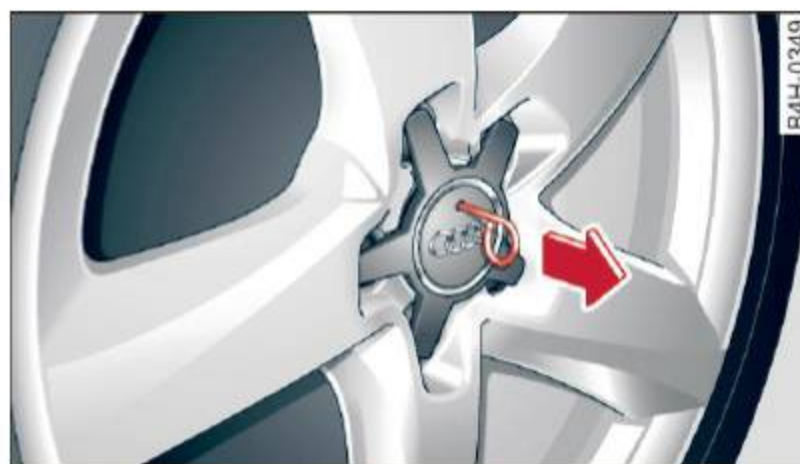

Fig. 221 Changing a wheel: Removing the wheel cover

Removing

- ▶ Insert the **hook** (provided with the vehicle tool kit) in the hole in the wheel hub cover. ▶

- ▶ Pull off the **decorative wheel cover**
⇒ *fig. 221.*

Wheels with wheel bolt caps

Applies to vehicles: with wheel bolts with caps

The caps must be removed first from the wheel bolts before the bolts can be unscrewed.



Fig. 222 Changing a wheel: removing the wheel bolt caps

Removing

- ▶ Push the **plastic clip** (provided with the vehicle tool kit) over the wheel bolt cap until the inner retainers on the clip align with the edge of the cover.
- ▶ Remove the cap with the **plastic clip** (vehicle tool kit) ⇒ *fig. 222.*

Refitting

- ▶ Place the caps over the wheel bolts and push them back on.

The caps are to protect and keep the wheel bolts clean.

Loosening and tightening the wheel bolts

The wheel bolts must be loosened before raising the vehicle.



Fig. 223 Changing a wheel: loosening the wheel bolts

Loosening

- ▶ Slide the **wheel wrench** onto the wheel bolt as far as it will go.
- ▶ Take tight hold of the *end* of the wrench handle and turn the wheel bolts **counter-clockwise** about *one single* turn in the direction of arrow ⇒ *fig. 223.*

Tightening

- ▶ Slide the wheel wrench onto the wheel bolt as far as it will go.
- ▶ Take tight hold of the *end* of the wrench handle and turn each wheel bolt **clockwise** until it is seated.

⚠ WARNING

- Do not use force or hurry when changing a wheel - you can cause the vehicle to slip off the jack and cause serious personal injuries.
- *Do not* loosen the wheel bolts *more than one turn* before you raise the vehicle with the jack. - You risk an injury.

📄 Tips

- Never use the hexagonal socket in the handle of the screwdriver to loosen or tighten the wheel bolts.
- If a wheel bolt is very tight, you may find it easier to loosen by carefully pushing down on the end of the wheel bolt wrench with *one foot only*. As you do so,

hold on to the car to keep your balance and take care not to slip.

Raising the vehicle

The vehicle must be lifted with the jack first before the wheel can be removed.

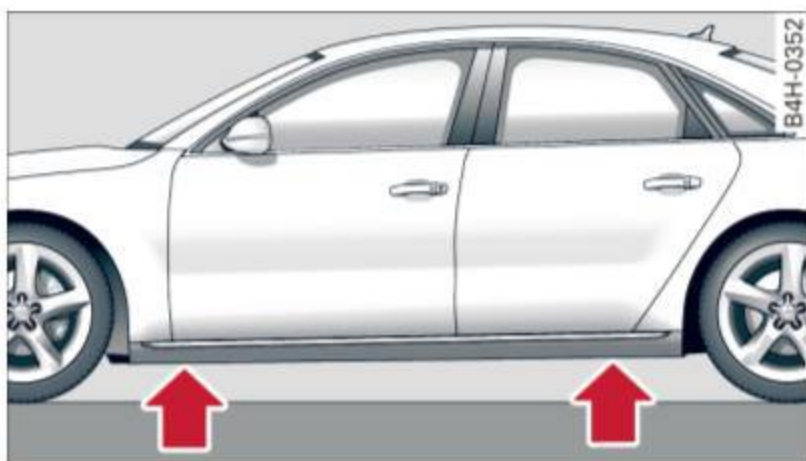

Fig. 224 Sill panels: markings

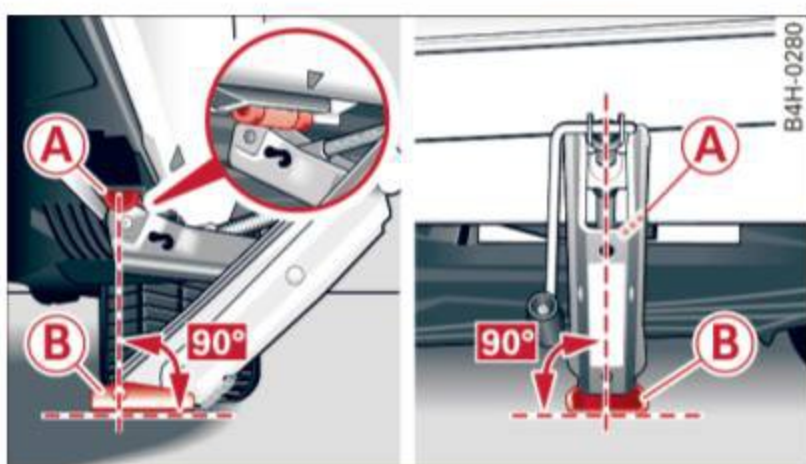

Fig. 225 Sill: positioning the vehicle jack

- ▶ Activate the vehicle jack mode in the MMI: **CAR** function button > **Car systems** control button > **Servicing & checks** > **Air susp.:** **jack mode** > **On**.
- ▶ Engage the **parking brake** to prevent your vehicle from rolling unintentionally.
- ▶ Move the **selector lever to position P**.
- ▶ Find the **marking** (imprint) on the sill that is nearest the wheel that will be changed ⇒ *fig. 224*. Behind the marking, there is a **lifting point** on the sill for the vehicle jack.
- ▶ Turn the **vehicle jack** located under the lifting point on the sill to raise the jack until its arm **(A)** ⇒ *fig. 225* is located under the designated plastic mount ⇒ ⚠ ⇒ !.
- ▶ Align the jack so that its arm **(A)** ⇒ *fig. 225* engages in the designated lifting point in the door sill and the movable base **(B)** lies flat on the ground. The base **(B)** must be **vertical** under the lifting point **(A)**.

- ▶ Wind the jack up further until the flat tire comes off the ground ⇒ ⚠.

Position the vehicle jack **only** under the designated lifting points on the sill ⇒ *fig. 224*. There is exactly **one** location for each wheel. The jack must not be positioned at any other location ⇒ ⚠ ⇒ !.

An **unstable surface** under the jack can cause the vehicle to slip off the jack. Always provide a firm base for the jack on the ground. If necessary place a sturdy board or similar support under the jack. On **hard, slippery surfaces** (such as tiles) use a rubber mat or similar to prevent the jack from slipping ⇒ ⚠.

⚠ WARNING

- You or your passengers could be injured while changing a wheel if you do not follow these safety precautions:
 - Position the vehicle jack only at the designated lifting points and align the jack. Otherwise, the vehicle jack could slip and cause an injury if it does not have sufficient hold on the vehicle.
 - A soft or unstable surface under the jack may cause the vehicle to slip off the jack. Always provide a firm base for the jack on the ground. If necessary, use a sturdy board under the jack.
 - On hard, slippery surface (such as tiles) use a rubber mat or similar to prevent the jack from slipping.
- To help prevent injury to yourself and your passengers:
 - Do not raise the vehicle until you are sure the jack is securely engaged.
 - Passengers must not remain in the vehicle when it is jacked up.
 - Make sure that passengers wait in a safe place away from the vehicle and well away from the road and traffic.
 - Make sure jack position is correct, adjust as necessary and then continue to raise the jack.
 - Changes in temperature or load can affect the height of the vehicle.

! Note

Do not lift the vehicle by the sill. Position the vehicle jack only at the designated lifting points on the sill. Otherwise, your vehicle will be damaged.

i Tips

The vehicle jack mode switches off automatically at speeds above 10 km/h.

Taking the wheel off/installing the spare

Follow these instructions step-by-step for changing the wheel.



Fig. 226 Changing a wheel: using the screwdriver handle (with the blade removed) to turn the bolts

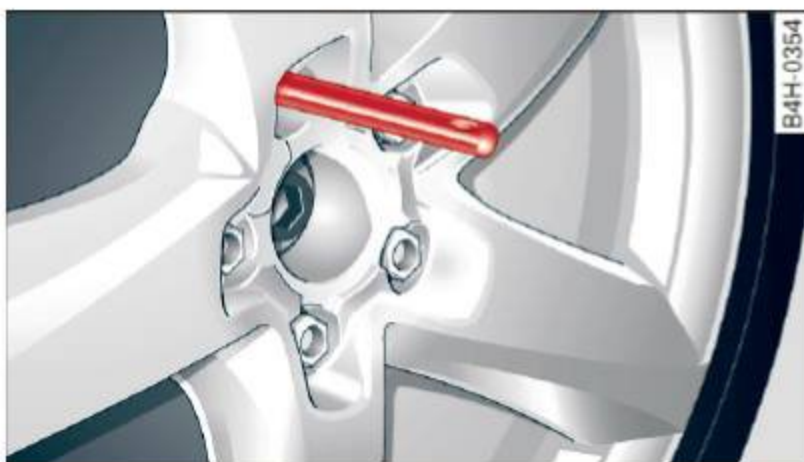

Fig. 227 Changing a wheel: alignment pin inside the top hole

After you have loosened all wheel bolts and raised the vehicle off the ground, remove and replace the wheel as follows:

Removing the wheel

- ▶ Use the **hexagonal socket in the screwdriver handle** to completely remove the top-most wheel bolt and set it aside on a *clean* surface ⇒ *fig. 226*.

- ▶ Screw the threaded end of the **alignment pin** from the tool kit hand-tight into the empty bolt hole ⇒ *fig. 227*.
- ▶ Then remove the other wheel bolts as described above.
- ▶ Take off the wheel leaving the alignment pin in the bolt hole ⇒ **!**

Putting on the spare wheel

- ▶ Lift the spare wheel and carefully slide it over the alignment pin to guide it in place ⇒ **!**
- ▶ Use the hexagonal socket in the screwdriver handle to screw in and tighten all wheel bolts *slightly*.
- ▶ Remove the alignment pin and insert and tighten the remaining wheel bolt slightly like the rest.
- ▶ Turn the jack handle counter-clockwise to lower the vehicle until the jack is fully released.
- ▶ Use the wheel bolt wrench to tighten all wheel bolts firmly ⇒ *page 274*. Tighten them *crosswise*, from one bolt to the (approximately) opposite one, to keep the wheel centered.

! Note

When removing or installing the wheel, the rim could hit the brake rotor and damage the rotor. Work carefully and have a second person help you.

i Tips

Never use the hexagonal socket in the handle of the screwdriver to loosen or tighten the wheel bolts.

- Pull the reversible blade from the screwdriver before you use the hexagonal socket in the handle to turn the wheel bolts.
- When mounting tires with **unidirectional tread design** make sure the tread pattern is pointed the right way ⇒ *page 277*.
- The wheel bolts should be clean and easy to turn. Check for dirt and corrosion on the mating surfaces of both the wheel

and the hub. Remove all dirt from these surfaces before remounting the wheel.

Tires with unidirectional tread design

Tires with unidirectional tread design must be mounted with their tread pattern pointed in the right direction.

Using a spare tire with a tread pattern intended for use in a specific direction

When using a spare tire with a tread pattern intended for use in a specific direction, please note the following:

- The direction of rotation is marked by an arrow on the side of the tire.
- If the spare tire has to be installed in the incorrect direction, use the spare tire only temporarily since the tire will not be able to achieve its optimum performance characteristics with regard to aquaplaning, noise and wear.
- We recommend that you pay particular attention to this fact during wet weather and that you adjust your speed to match road conditions.
- Replace the flat tire with a new one and have it installed on your vehicle as soon as possible to restore the handling advantages of a unidirectional tire.

Notes on wheel changing

Please read the information ⇒ *page 259, New tires and replacing tires and wheels* if you are going to use a spare tire which is different from the tires on your vehicle.

After you change a tire:

- **Check the tire pressure on the spare immediately after installation.**
- **Have the wheel bolt tightening torque checked with a torque wrench as soon as possible by your authorized Audi dealer or a qualified service station.**
- **With steel and alloy wheel rims, the wheel bolts are correctly tightened at a torque of 90 ft lb (120 Nm).**

- **If you notice that the wheel bolts are corroded and difficult to turn while changing a tire, they should be replaced before you check the tightening torque.**
- **Replace the flat tire with a new one and have it installed on your vehicle as soon as possible. Remount the wheel cover.**

Until then, drive with extra care and at reduced speeds.

WARNING

- If you are going to equip your vehicle with tires or rims which differ from those which were factory installed, then be sure to read the information ⇒ *page 259, New tires and replacing tires and wheels*.
- Always make sure the damaged wheel or even a flat tire and the jack and tool kit are properly secured in the luggage compartment and are not loose in the passenger compartment.
- In an accident or sudden maneuver they could fly forward, injuring anyone in the vehicle.
- Always store damaged wheel, jack and tools securely in the luggage compartment. Otherwise, in an accident or sudden maneuver they could fly forward, causing injury to passengers in the vehicle.

Fuses and bulbs

Fuses

Replacing fuses

Fuses that have blown will have metal strips that have burned through.

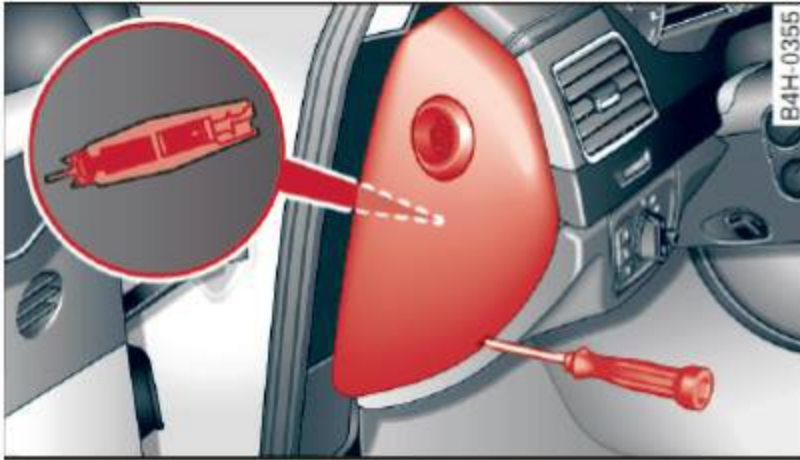

Fig. 228 Driver side of the cockpit: fuse panel cover

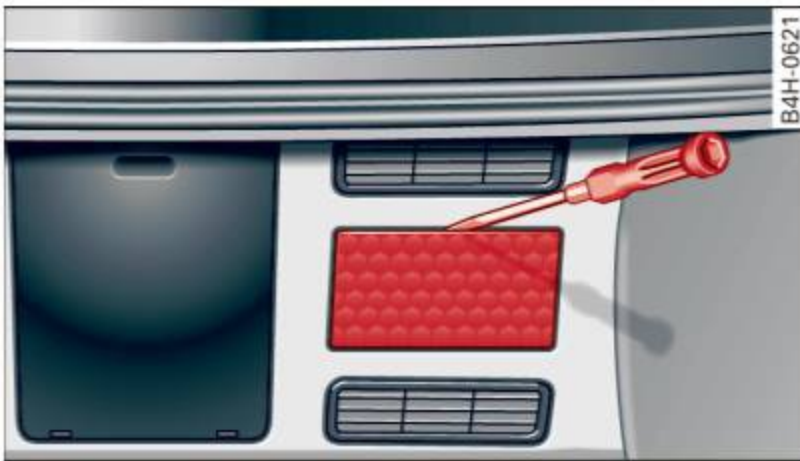

Fig. 229 Luggage compartment: fuse panel cover

The fuses are located on the left and right front sides of the cockpit and in the luggage compartment behind the rear seat trim panel.

- ▶ Switch the ignition and the affected electrical equipment off.
- ▶ Check the following table to see which fuse belongs to the consumer.
- ▶ Remove the appropriate cover.
- ▶ To remove the purple plastic clip if necessary ¹⁾, hold onto it at the small side and pull it out of the fuse panel ⇒ *page 278, fig. 230.*
- ▶ Remove the clamp from the rear side of the fuse cover ⇒ *fig. 228.*
- ▶ Remove the fuse using the clamp and replace the blown fuse with an identical new one.

¹⁾ You can dispose of the plastic clip after removing it.

⚠ WARNING

Do not repair fuses and never replace a blown fuse with one that has a higher amp rating. This can cause damage to the electrical system and a fire.

! Note

If a new fuse burns out again shortly after you have installed it, have the electrical system checked by your authorized Audi dealer.

i Tips

- The following table does not list fuse locations that are not used.
- Some of the equipment items listed are optional or only available on certain model configurations.

Driver side cockpit fuse assignment

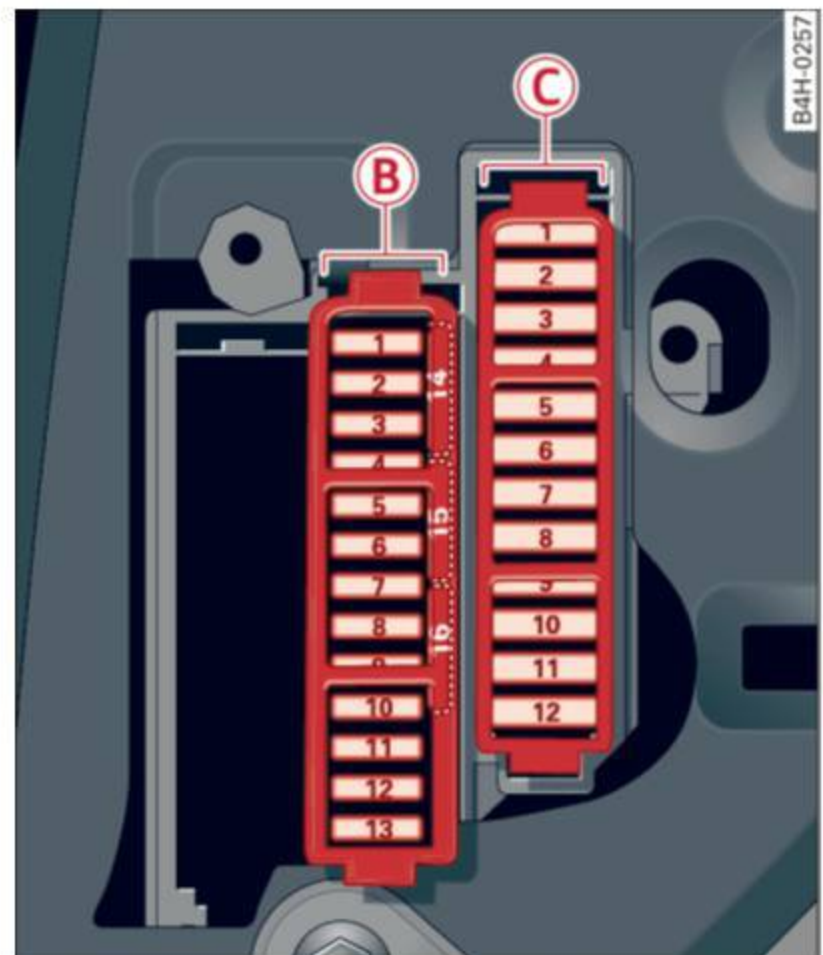

Fig. 230 Driver side cockpit: fuse panel with plastic bracket

Fuse panel (B) (brown)

No.	Equipment	Amps
1	Headlight control switch	5
2	Emergency start coil (key identification)	5
3	Rear door control module (driver's side)	7,5
5	Horn	15
6	Interior lights (headliner)	7,5
8	Steering column lever, multifunction steering wheel controls, steering wheel heating	10/5
10	Electric steering column lock	5
11	Driver door control module	7,5
12	Diagnostic connector, light/rain sensor	10
14	Power steering column adjustment	25
15	Power steering, A/C compressor	20
16	Brake booster	15

Fuse panel (C) (black)

No.	Equipment	Amps
1	Front seat heating	30
2	Windshield wiper	30
3	Front exterior lighting	30
4	Sun roof	20
5	Driver power window	30
6	Driver seat (pneumatic)	7,5
7	Panoramic sunroof	20
8	Dynamic steering	35
9	Front exterior lighting	30
10	Windshield/headlight washer system	35
11	Rear power window (driver's side)	30
12	Panoramic sunroof	40

Front passenger side cockpit fuse assignment

Fig. 231 Front passenger side cockpit: fuse panel with plastic bracket

Fuse panel (B) (black)

No.	Equipment	Amps
1	Anti-theft alarm system	5
2	Transmission control module	15
3	Front climate control fan	40
4	Engine supply	35
6	Engine control module	5
7	Front passenger door control module	7,5
8	Front passenger power window	30
9	ESC control module	10
10	ESC control module	25
11	Right rear power window	30
12	Front passenger seat (pneumatics)	7,5

Luggage compartment fuse assignment

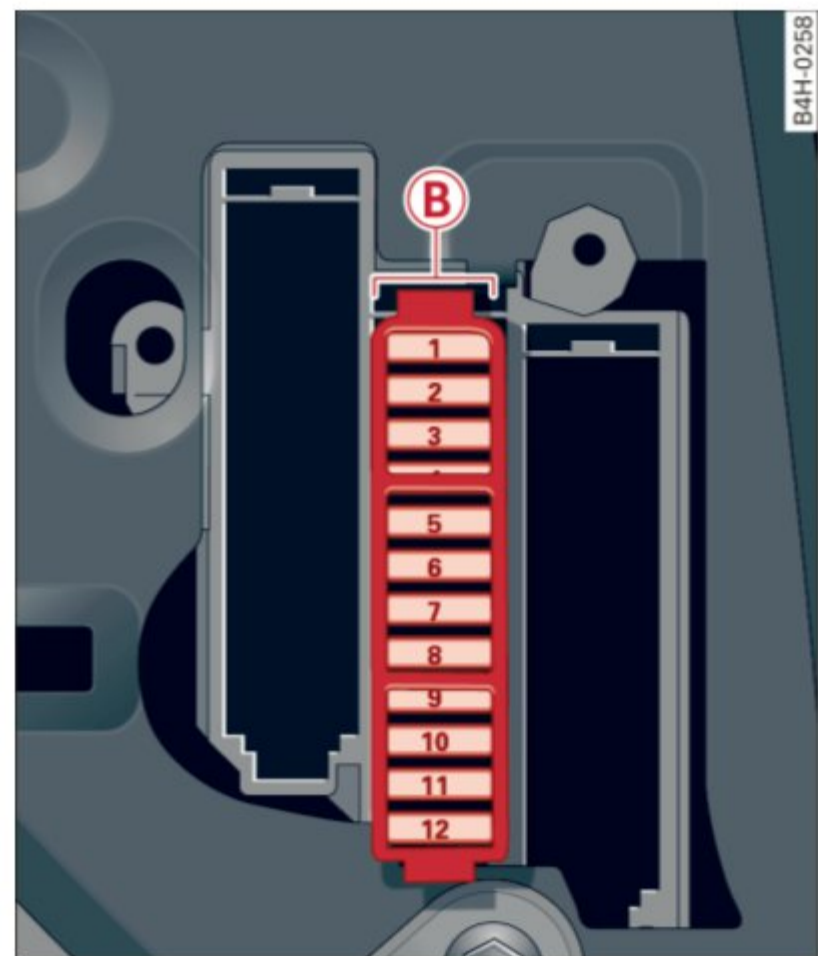
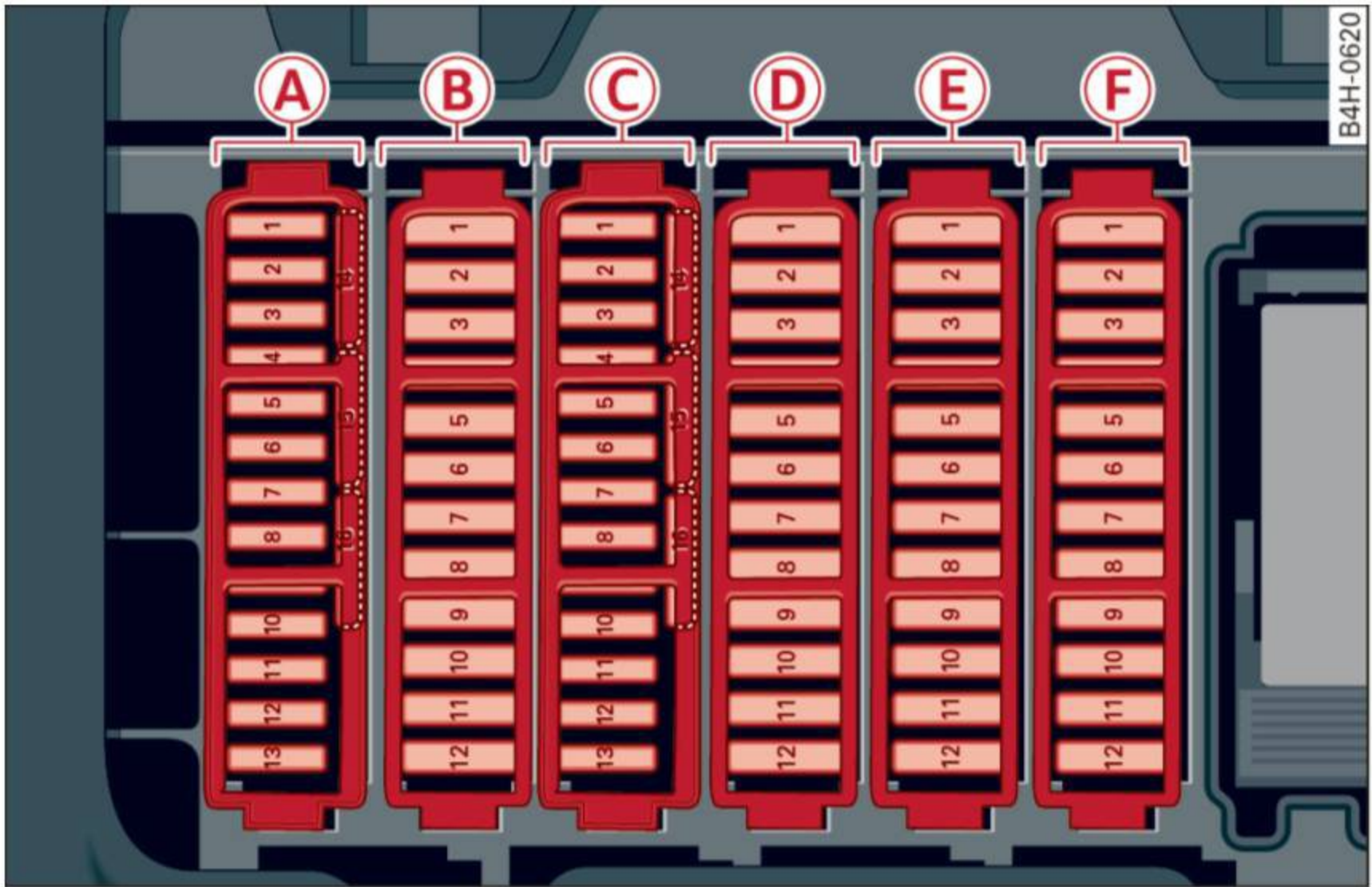

Fig. 232 Luggage compartment: fuse panel with plastic bracket

Fuse panel **A** (black)

No.	Equipment	Amps
1	ESC button, data logger, diagnostic connector, BCM - 1, adaptive lighting system	5
2	Networking gateway	5
3	adaptive air suspension	5
4	Parking system	5
5	Steering column lever	5
6	Suspension control system sensor	5
7	Belt tensioners, airbag control module	5
8	Heated washer fluid nozzles, HomeLink (garage door opener), night vision system control module, sport differential, ionizer	5
9	Electromechanical parking brake control module	5
10	Rear seat heating, cooler, interior rearview mirror	5

No.	Equipment	Amps
11	Dynamic steering	5
12	Selector lever, BCM-2	5
13	Audi side assist	5
14	Engine control module	5
15	Starter	40
16	Left headlight/Headlight range control system	10/5

Fuse panel **B** (red)

No.	Equipment	Amps
1	Left reversible belt tensioner	25
2	Right reversible belt tensioner	25
3	Starter diagnosis, DC/DC converter (Start-Stop-System)	5
4	DC/DC converter (Start-Stop-System)	7,5
5	Image processing	7,5

No.	Equipment	Amps
6	Right headlight (headlight with adaptive light)	10
7	ESC control module	5
8	Sound actuator, AEM control module	7,5
9	Adaptive cruise control	10
10	Transmission control module	5
11	Climate control system sensors	5

Fuse panel **(C)** (brown)

No.	Equipment	Amps
1	Electromechanical parking brake	5
2	Suspension control system sensor	5
3	Right rear door control module	7,5
4	Smart modul tank	5
5	Front climate control system controls	15
6	Rear climate control system controls	10
7	Networking gateway	5
8	Cooler	15
9	Interface for special functions	5
10	Cell phone adapter, Bluetooth handset	5
11	AEM control module	15
12	Selector lever	10
13	Ambient lighting	10
14	Rear exterior lighting	20
15	Fuel pump	25
16	Electromechanical parking brake	30

Fuse panel **(D)** (black)

No.	Equipment	Amps
1	Automatic luggage compartment lid	5
3	Rear sockets	20
5	adaptive air suspension	15
6	115-V socket	25
7	Electromechanical parking brake	30
8	Rear seat heating	25
9	Rear exterior lighting	20
10	Rear climate control system blower	20
11	Rear sun shade, closing aid, luggage compartment lock, convenience key, fuel filler door	20
12	Luggage compartment lid control module	30

Fuse panel **(E)** (red)

No.	Equipment	Amps
1	Rear seat adjustment buttons	5
3	Left rear seat (pneumatics)	7,5
5	Trailer hitch control module*	20
6	Left rear seat	30
7	Right rear seat	30
8	Trailer hitch control module*	20
9	Trailer hitch control module*	15
10	Right rear seat (pneumatics)	7,5

Fuse panel **(F)** (brown)

No.	Equipment	Amps
1	Start-Stop-System, Radio receiver/sound amplifier	30
2	Sound amplifier	30
3	Start-Stop-System, Rear Seat Entertainment, radio receiver/sound amplifier	7,5
5	Automatic dimming interior rearview mirror	5
6	DVD changer	5

No.	Equipment	Amps
7	TV tuner	5
8	Infotainment unit/drives	7,5
9	Instrument cluster, analog clock	5
10	MMI Display	5
11	Radio receiver	7,5
12	Rearview camera (parking aid), Top view	5

Bulbs

Replacing light bulbs

For your safety, we recommend that you have your authorized Audi dealer replace burned out bulbs for you.

It is becoming increasingly more and more difficult to replace vehicle light bulbs since in many cases, other parts of the car must first be removed before you are able to get to the bulb. This applies especially to the light bulbs in the front of your car which you can only reach through the engine compartment.

Sheet metal and bulb holders can have sharp edges that can cause serious cuts, and parts must be correctly taken apart and then properly put back together to help prevent breakage of parts and long term damage from water that can enter housings that have not been properly resealed.

For your safety, we recommend that you have your authorized Audi dealer replace any bulbs for you, since your dealer has the proper tools, the correct bulbs and the expertise.

Gas discharge lamps (Xenon lights):

Due to the high electrical voltage, have the bulbs replaced by a qualified technician. Headlights with Xenon light can be identified by the high voltage sticker.

LED headlights* require no maintenance. Please contact your authorized Audi dealer if a bulb needs to be replaced.

WARNING

Contact with high-voltage components of the electrical system and improper replacement of gas discharge (Xenon) headlight bulbs can cause serious personal injury and death.

- Xenon bulbs are pressurized and can explode when being changed.
- Changing Xenon lamps requires the special training, instructions and equipment.
- Only an authorized Audi dealer or other qualified workshop should change the bulbs in gas discharge lamps.

WARNING

There are parts with sharp edges on the openings and on the bulb holders that can cause serious cuts.

- If you are uncertain about what to do, have the work performed by an authorized Audi dealer or other qualified workshop. Serious personal injury may result from improperly performed work.

Tips

- If you must replace the light bulbs yourself, always remember that the engine compartment of any vehicle is a hazardous area to work in. Always read and heed all WARNINGS ⇒ page 231.
- It is best to ask your authorized Audi dealer whenever you need to change a bulb.

Emergency situations

General

This chapter is intended for trained emergency crews and working personnel who have the necessary tools and equipment to perform these operations.

Starting by pushing or towing

Note

Vehicles with an automatic transmission cannot be started by pushing or towing.

Starting with jumper cables

If necessary, the engine can be started by connecting it to the battery of another vehicle.

If the engine should fail to start because of a discharged or weak battery, the battery can be connected to the battery of *another* vehicle, using a **pair of jumper cables** to start the engine.

Jumper cables

Use *only* jumper cables of sufficiently large **cross section** to carry the starter current safely. Refer to the manufacturer's specifications.

Use only jumper cables with *insulated* terminal clamps which are distinctly marked:

plus (+) cable in most cases colored **red**

minus (-) cable in most cases colored **black**.

WARNING

Batteries contain electricity, acid, and gas. Any of these can cause very serious or fatal injury. Follow the instructions below for safe handling of your vehicle's battery.

- Always shield your eyes and avoid leaning over the battery whenever possible.
- A discharged battery can freeze at temperatures just below 32 °F (0 °C). Before

connecting a jumper cable, you must thaw the frozen battery completely, otherwise it could explode.

- Do not allow battery acid to contact eyes or skin. Flush any contacted area with water immediately.
- Improper use of a booster battery to start a vehicle may cause an explosion.
- Vehicle batteries generate explosive gases. Keep sparks, flame and lighted cigarettes away from batteries.
- Do not try to jump start any vehicle with a low acid level in the battery.
- The voltage of the booster battery must also have a 12-Volt rating. The capacity (Ah) of the booster battery should not be lower than that of the discharged battery. Use of batteries of different voltage or substantially different "Ah" rating may cause an explosion and personal injury.
- Never charge a frozen battery. Gas trapped in the ice may cause an explosion.
- Never charge or use a battery that has been frozen. The battery case may have been weakened.
- Use of batteries of different voltage or substantially different capacity (Ah) rating may cause an explosion and injury. The capacity (Ah) of the booster battery should not be lower than that of the discharged battery.
- Before you check anything in the engine compartment, always read and heed all **WARNINGS** ⇨ *page 231*.

Note

- Applying a higher voltage booster battery will cause expensive damage to sensitive electronic components, such as control units, relays, radio, etc.
- There must be no electrical contact between the vehicles as otherwise current could already start to flow as soon as the positive (+) terminals are connected.

i Tips

- The discharged battery must be properly connected to the vehicle's electrical system. When jump starting or charging the battery, never connect the negative ground cable to the battery negative post because the battery manager system must be able to detect the battery's state of charge. Always connect the negative ground cable to the negative ground post of the battery manager control unit.

Use of jumper cables

Make sure to connect the jumper cable clamps in exactly the order described below!

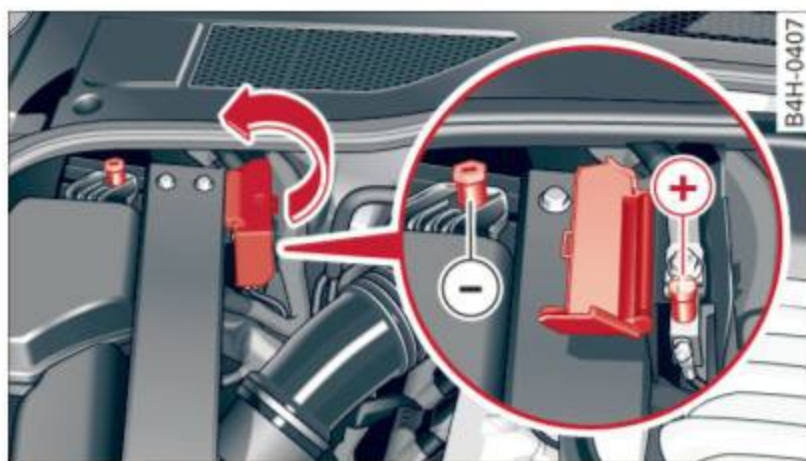

Fig. 233 Engine compartment: connectors for jump start cables and charger

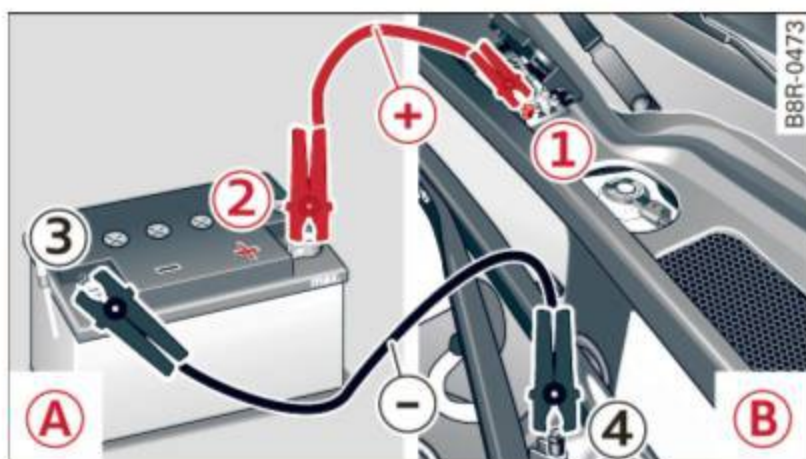

Fig. 234 Jump starting with the battery of another vehicle: (A) – booster battery, (B) – discharged vehicle battery

The procedure described below for connecting jumper cables is intended to provide a jump start for your vehicle.

Vehicle with discharged battery:

- ▶ Turn off lights and accessories, move lever of automatic transmission to N (Neutral) or P (Park) and set parking brake.

Connect POSITIVE (+) to POSITIVE (+) (red)

- ▶ Open the red cover on the positive terminal ⇒ fig. 233.
1. Connect one end of the red positive cable on the **jump start bolt** ⇒ fig. 234 (1) (bolt under the red cover = “positive”) of the vehicle to be started (B).
 2. Connect the other end to the positive terminal (2) of the booster battery (A).

Connect NEGATIVE (-) to NEGATIVE (-) (black)

3. Connect one end of the black negative cable to the negative terminal (3) of the booster battery (A).
4. Connect the other end to the **jump start pin** (4) (bolts with hex head bolt = “negative”) of the vehicle to be started (B).

Starting the engine

- ▶ Start the engine of the vehicle with the booster battery (A). Run the engine at a moderate speed.
- ▶ Start engine with discharged vehicle battery (B) in the usual manner.
- ▶ If the engine fails to start, do not keep the starter cranking for longer than 10 seconds. Wait for about 30 seconds and then try again.
- ▶ With engine running, remove jumper cables from both vehicles in the exact reverse order.
- ▶ Close the red cover on the positive terminal.

The battery is vented to the outside to prevent gases from entering the vehicle interior. Make sure that the jumper clamps are well connected with their metal parts in full contact with the battery terminals.

! WARNING

To avoid serious personal injury and damage to the vehicle, heed all warnings and instructions of the jumper cable manufacturer. If in doubt, call for road service.

- Jumper cables must be long enough so that the vehicles do not touch.

- When connecting jumper cables, make sure that they cannot get caught in any moving parts in the engine compartment.
- Before you check anything in the engine compartment, always read and heed all WARNINGS ⇒ page 231.

! Note

Improper hook-up of jumper cables can ruin the generator.

- Always connect POSITIVE (+) to POSITIVE (+), and NEGATIVE (-) to NEGATIVE (-) ground post of the battery manager control unit.
- Check that all screw plugs on the battery cells are screwed in firmly. If not, tighten plugs prior to connecting clamp on negative battery terminal.
- Please note that the procedure for connecting a jumper cable as described above applies specifically to the case of your vehicle being jump started. When you are giving a jump start to another vehicle, do *not* connect the negative (-) cable to the negative (-) terminal on the discharged battery ④ ⇒ fig. 234. Instead, securely connect the negative (-) cable to either a solid metal component that is firmly bolted to the engine block or to the engine block itself. If the battery that is being charged does not vent to the outside, escaping battery gas could ignite and explode!

Emergency towing with commercial tow truck

General hints

Your Audi requires special handling for towing.

The following information is to be used by commercial tow truck operators who know how to operate their equipment safely.

- **Never tow your Audi. Towing will cause damage to the engine and transmission.**
- **Never wrap the safety chains or winch cables around the brake lines.**
- **To prevent unnecessary damage, your Audi must be transported with a flat bed truck.**
- **To load the vehicle on to the flat bed, use the towing loop found in the vehicle tools and attach to the front or rear anchorage ⇒ page 285 and ⇒ page 286.**

! WARNING

A vehicle being towed is not safe for passengers. Never allow anyone to ride in a vehicle being towed, for any reason.

Front towing loop

Only install the front towing loop when it is needed.



Fig. 235 Front bumper: cover



Fig. 236 Front bumper: screwing in the towing loop

The towing loop fits into the threaded hole located on the right side of the front bumper and covered by a small cover when not in use.

- ▶ Remove the towing loop from the vehicle tool kit.

- ▶ Press inward strongly on the left side of the cap to remove it from the bumper ⇒ *fig. 235*.
- ▶ Screw the towing loop in the threaded opening and tighten it until it stops ⇒ *fig. 236*.

Remove the towing loop when you are done using it and place it back in the vehicle tool kit. Install the cover in the bumper. Always keep the towing loop in the vehicle.

WARNING

If you do not screw the towing loop completely, it could come out of the threaded hole while the vehicle is being towed causing damage to the vehicle and possible serious personal injury.

Rear towing loop

Only install the rear towing loop when it is needed.

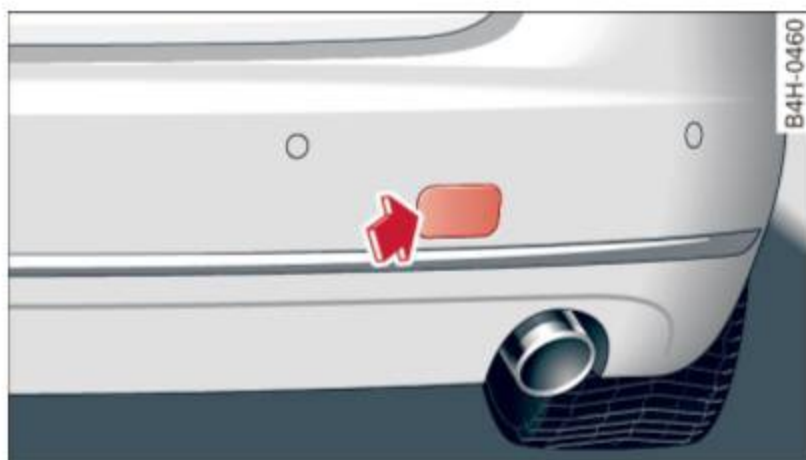

Fig. 237 Rear bumper: cover

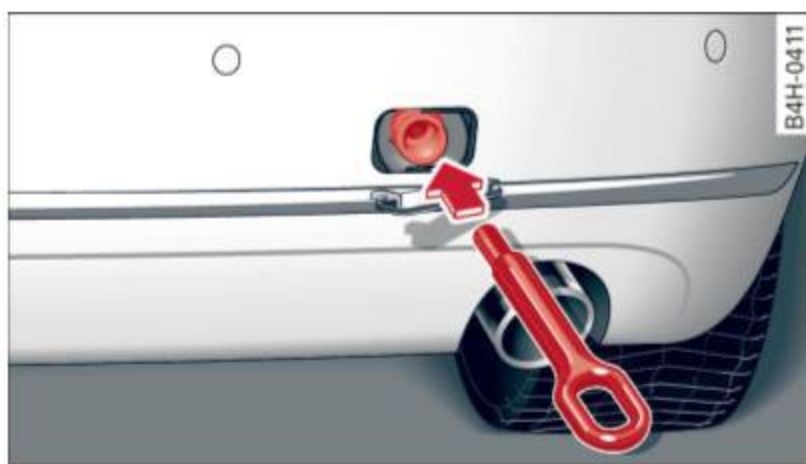

Fig. 238 Rear bumper: screwing in towing loop

There are threads located behind the right side of the rear bumper where a towing loop can be installed. The threads are located behind a cover.

- ▶ Remove the towing loop from the vehicle tool kit.
- ▶ Press inward strongly on the left side (A8)/ upper side (S8) of the cap to remove it from the bumper ⇒ *fig. 237*.
- ▶ Screw the towing loop in the threaded opening and tighten it until it stops. The indicator marking must be flush with the bumper ⇒ *fig. 238*.

Remove the towing loop when you are done using it and place it back in the vehicle tool kit. Always keep the towing loop in the vehicle.

WARNING

If you do not screw the towing loop completely, it could come out of the threaded hole while the vehicle is being towed causing damage to the vehicle and possible serious personal injury.

Loading the vehicle onto a flat bed truck



Fig. 239 Vehicle on flat bed truck

Front hook up

- ▶ Align the vehicle with the centerline of the car carrier ramp.
- ▶ Attach the winch hook to the front towline eye previously installed.

Rear hook up

- ▶ Align the vehicle with the centerline of the car carrier ramp.
- ▶ Attach the winch hook to the rear towline eye previously installed.

i Tips

Check carefully to make sure the hook-up is secure before moving the car up the flat-bed truck ramp.

Vehicle transport

Whenever you have your vehicle transported, be sure to note the following:

! Note

Mount the tie-down chains/cables over the running surface (circumference) of the tires. Never secure the vehicle by the axle, the suspension struts or the front or rear towline eye. For technical reasons, the pressure in the suspension struts may change during the transport and this will adversely affect vehicle handling.

Lifting vehicle**Lifting with workshop hoist and with floor jack**

The vehicle may only be lifted at the lifting points illustrated.

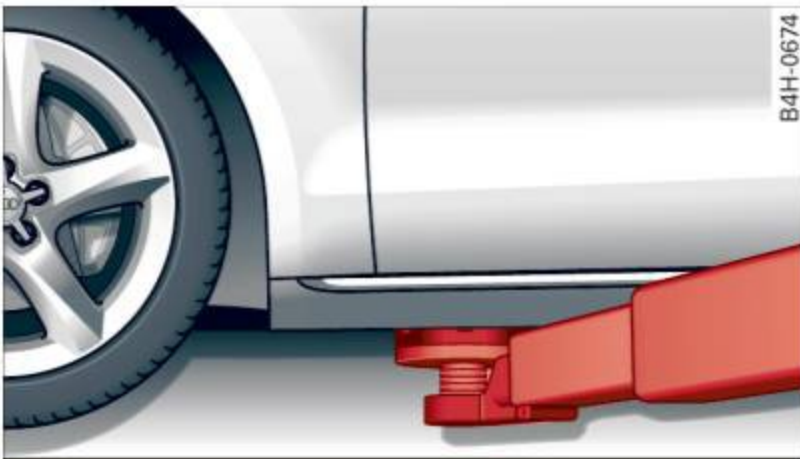

Fig. 240 Front lifting point

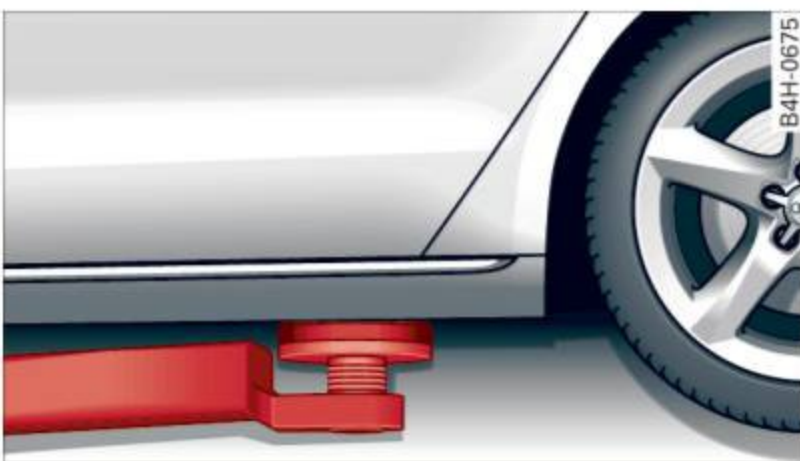

Fig. 241 Rear lifting point

- ▶ Read and heed WARNING ⇨

- ▶ Activate the vehicle jack mode in the MMI: **CAR** function button > **Car systems** control button > **Servicing & checks** > **Air susp.: jack mode** > **On**.
- ▶ Locate lifting points ⇨ *fig. 240* and ⇨ *fig. 241*.
- ▶ Adjust lifting arms of workshop hoist or floor jack to match vehicle lifting points.
- ▶ Insert a rubber pad between the floor jack/workshop hoist and the lifting points.

The vehicle jack mode must be activated so that the automatic adjustment of the Adaptive Air Suspension does not make it more difficult to raise the vehicle with the floor jack.

If you must lift your vehicle with a floor jack to work underneath, be sure the vehicle is safely supported on stands intended for this purpose.

Front lifting point

The lifting point is located on the floor pan reinforcement about at the same level as the jack mounting point ⇨ *fig. 240*. **Do not lift the vehicle at the vertical sill reinforcement.**

Rear lifting point

The lifting point is located on the vertical reinforcement of the lower sill for the on-board jack ⇨ *fig. 241*.

Lifting with vehicle jack

Refer to ⇨ *page 275*.

! WARNING

- To reduce the risk of serious injury and vehicle damage.
- Always lift the vehicle only at the special workshop hoist and floor jack lift points illustrated ⇨ *fig. 240* and ⇨ *fig. 241*.
- Failure to lift the vehicle at these points could cause the vehicle to tilt or fall from a lift if there is a change in vehicle weight distribution and balance. This might happen, for example, when heavy components such as the engine block or transmission are removed.

- When removing heavy components like these, anchor vehicle to hoist or add corresponding weights to maintain the center of gravity. Otherwise, the vehicle might tilt or slip off the hoist, causing serious personal injury.

! **Note**

- Be aware of the following points before lifting the vehicle:
 - **The vehicle should never be lifted or jacked up from underneath the engine oil pan, the transmission housing, the front or rear axle or the body side members. This could lead to serious damage.**
 - **To avoid damage to the underbody or chassis frame, a rubber pad must be inserted between the floor jack and the lift points.**
 - **Before driving over a workshop hoist, check that the vehicle weight does not exceed the permissible lifting capacity of the hoist.**
 - **Before driving over a workshop hoist, ensure that there is sufficient clearance between the hoist and low parts of the vehicle.**

Technical Data

Vehicle identification



Fig. 242 Vehicle Identification Number (VIN) plate: location on driver's side dash panel

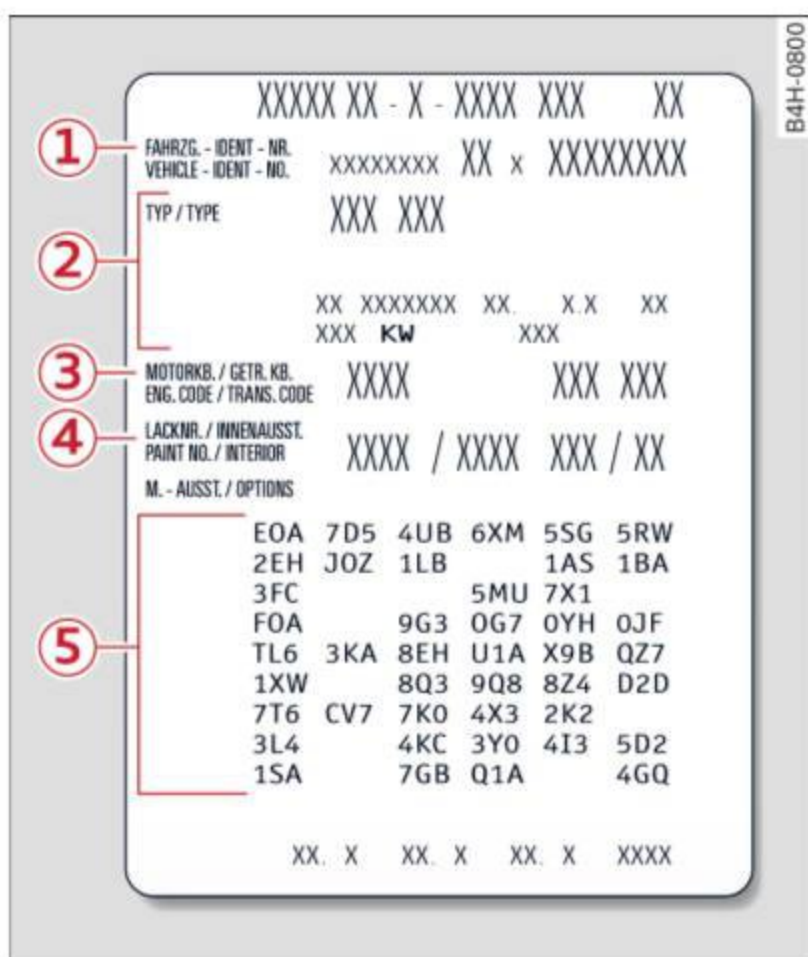

Fig. 243 The vehicle identification label - inside the luggage compartment

Vehicle Identification Number (VIN)

The Vehicle Identification Number is located in different places:

- under the windshield on the driver's side ⇒ *fig. 242*.
- in the MMI: Select: Function button **CAR** > **Car systems** > **VIN number**.
- on the vehicle identification label.

Vehicle identification label

The vehicle identification label is located in the luggage compartment in the spare wheel well.

The label ⇒ *fig. 243* shows the following vehicle data:

- 1 Vehicle Identification Number (VIN)
- 2 Vehicle type, engine output, transmission
- 3 Engine and transmission code
- 4 Paint number and interior
- 5 Optional equipment numbers

The information of the vehicle identification label can also be found in your Warranty & Maintenance booklet.

Safety compliance sticker

The safety compliance sticker is your assurance that your new vehicle complies with all applicable Federal Motor Vehicle Safety Standards which were in effect at the time the vehicle was manufactured. You can find this sticker on the door jamb on the driver's side. It shows the month and year of production and the vehicle identification number of your vehicle (perforation) as well as the Gross Vehicle Weight Rating (GVWR) and the Gross Axle Weight Rating (GAWR).

High voltage warning label

The high voltage warning label is located in the engine compartment next to the engine hood release. The spark ignition system complies with the Canadian standard ICES-002.

Weights

Gross Vehicle Weight Rating

The Gross Vehicle Weight Rating (GVWR), and the Gross Axle Weight Rating (GAWR) for front and rear are listed on a sticker on the door jamb on the driver's side.

The Gross Vehicle Weight Rating includes the weight of the basic vehicle plus full fuel tank, oil and coolant, plus maximum load, which includes passenger weight (150 lbs/68 kg per designated seating position) and luggage weight ⇒ .

Gross Axle Weight Rating

The Gross Axle Weight Rating is the maximum load that can be applied at each axle of the vehicle ⇒ ⚠.

Vehicle capacity weight

The vehicle capacity weight (max. load) is listed either on the driver's side B-pillar or inside the fuel filler flap.

WARNING

- The actual Gross Axle Weight Rating at the front and rear axles should not exceed the permissible weights, and their combination must not exceed the Gross Vehicle Weight Rating.

- Exceeding permissible weight ratings can result in vehicle damage, accidents and personal injury.

Note

- The vehicle capacity weight figures apply when the load is distributed evenly in the vehicle (passengers and luggage). When transporting a heavy load in the luggage compartment, carry the load as near to the rear axle as possible so that the vehicle's handling is not impaired.
- Do not exceed the maximum permissible axle loads or the maximum gross vehicle weight. Always remember that the vehicle's handling will be affected by the extra load. Therefore, adjust your speed accordingly.
- Always observe local regulations.

Dimensions

		A8	S8	A8L
Length	in (mm)	202.4 (5137)	202.2 (5136)	207.52 (5267)
Width	in (mm)	76.7 (1949)	76.7 (1949)	76.7 (1949)
Width (across mirrors)	in (mm)	83.17 (2111)	83.17 (2111)	83.17 (2111)
Height (unloaded) ^{a)}	in (mm)	57.52 (1460)	57.4 (1458)	57.96 (1471)
Turning circle diameter	ft (m)	40.35 (12.3)	40.35 (12.3)	41.67 (12.7)

^{a)} The height of the vehicle depends on the tires and the suspension.

When driving up steep ramps, on rough roads, over curbs, etc. it is important to remember that some parts of your vehicle, such as spoil-

ers or exhaust system components, may be close to the ground. Be careful not to damage them.

Capacities

Fuel tank: total capacity	gal (liters)	approx. 23.8 (90.0)
Windshield and headlight* washer fluid container	quarts (liters)	approx. 5.29 (5.0)

Gasoline engines

A8 3.0, 6 cylinder

Maximum output SAE net	hp @ rpm	333 @ 5500 - 6500
Maximum torque SAE net	lb-ft @ rpm	325 @ 2900 - 5300
Displacement	CID (cm ³)	182.7 (2995)
Engine oil with filter change	quarts (liters)	7.19 (6.8)
Fuel	Premium unleaded (91 AKI) , ⇨ <i>page 222, Gasoline</i>	

A8 4.0, 8 cylinder

Maximum output SAE net	hp @ rpm	420 @ 5000
Maximum torque SAE net	lb-ft @ rpm	444 @ 1500
Displacement	CID (cm ³)	243.57 (3993)
Engine oil with filter change	quarts (liters)	8.77 (8.3)
Fuel	Premium unleaded (91 AKI) , ⇨ <i>page 222, Gasoline</i>	

S8 4.0, 8 cylinder

Maximum output SAE net	hp @ rpm	520 @ 6000
Maximum torque SAE net	lb-ft @ rpm	479 @ 1700 - 5500
Displacement	CID (cm ³)	243.57 (3993)
Engine oil with filter change	quarts (liters)	8.77 (8.3)
Fuel	Premium unleaded (91 AKI) , ⇨ <i>page 222, Gasoline</i>	

A8 6.3, 12 cylinder

Maximum output SAE net	hp @ rpm	500 @ 6200
Maximum torque SAE net	lb-ft @ rpm	463 @ 4750
Displacement	CID (cm ³)	384.39 (6299)
Engine oil with filter change	quarts (liters)	12.16 (11.5)
Fuel	Premium unleaded (91 AKI) , ⇨ <i>page 222, Gasoline</i>	

Diesel engine

A8 3.0 TDI, 6 cylinder

Maximum output SAE net	hp @ rpm	240 @ 3550 - 6500
Maximum torque SAE net	lb-ft @ rpm	407 @ 1750 - 2000
Displacement	CID (cm ³)	181.03 (2967)
Engine oil with filter change	quarts (liters)	6.8 (6.4)
Fuel	ULSD-Diesel No. 2 , ⇨ <i>page 223, Diesel fuel</i>	

Consumer Information

Warranty coverages

Your Audi is covered by the following warranties:

- *New Vehicle Limited Warranty*
- *Limited Warranty Against Corrosion Perforation*
- *Emissions Control System Warranty*
- *Emissions Performance Warranty*
- *California Emissions Control Warranty (USA vehicles only)*
- *California Emissions Performance Warranty (USA vehicles only)*

Detailed information regarding your warranties can be found in your **Warranty & Maintenance booklet**.

Operating your vehicle outside the U.S.A. or Canada

Government regulations in the United States and Canada require that automobiles meet specific emission regulations and safety standards. Therefore, vehicles built for the U.S.A. and Canada differ from vehicles sold in other countries.

If you plan to take your vehicle outside the continental limits of the United States or Canada, there is the possibility that:

- unleaded fuels for vehicles with catalytic converter may not be available;
- fuel may have a considerably lower octane rating. Improper fuel may cause engine damage;
- service may be inadequate due to lack of proper service facilities, tools or testing equipment;
- replacement parts may not be readily available.
- Navigation systems for vehicles built for the U.S.A. and Canada will not necessarily work in Europe, and may not work in other countries outside North America.

Note

Audi cannot be responsible for mechanical damage that could result from inadequate fuel, service or parts availability.

Audi Service Repair Manuals and Literature

Audi Official Factory Service Manuals and Literature are published as soon as possible after model introduction. Service manuals and literature are available to order from the Audi Technical Literature Ordering Center at:

www.audi.techliterature.com

Maintenance

General

Your vehicle has been designed to help keep maintenance requirements to a minimum. However, a certain amount of regular maintenance is still necessary to assure your vehicle's safety, economy and reliability. For detailed vehicle maintenance consult your Warranty & Maintenance booklet.

Under difficult operating conditions, for example at extremely low outside temperatures, in very dusty regions, when towing a trailer very frequently, etc., some service work should be performed between the intervals specified. This applies particularly to:

- oil changes, and
- cleaning or replacing the air filter.

For the sake of the environment

By regularly maintaining your vehicle, you help make sure that emission standards are maintained, thus minimizing adverse effects on the environment.

Important considerations for you and your vehicle

The increasing use of electronics, sophisticated fuel injection and emission control systems, and the generally increasing technical

complexity of today's automobiles, have steadily reduced the scope of maintenance and repairs which can be carried out by vehicle owners. **Also, safety and environmental** concerns place very strict limits on the nature of repairs and adjustments to engine and transmission parts which an owner can perform.

Maintenance, adjustments and repairs usually require special tools, testing devices and other equipment available to specially trained workshop personnel in order to assure proper performance, reliability and safety of the vehicle and its many systems.

Improper maintenance, adjustments and repairs can impair the operation and reliability of your vehicle and even void your vehicle warranty. Therefore, proof of servicing in accordance with the maintenance schedule may be a condition for upholding a possible warranty claim made within the warranty period.

Above all, operational safety can be adversely affected, creating unnecessary risks for you and your passengers.

If in doubt about any servicing, have it done by your authorized Audi dealer or any other properly equipped and qualified workshop. We strongly urge you to give your authorized Audi dealer the opportunity to perform all scheduled maintenance and necessary repairs. Your dealer has the facilities, original parts and trained specialists to keep your vehicle running properly.

Performing limited maintenance yourself

The following pages describe a limited number of procedures which can be performed on your vehicle with ordinary tools, should the need arise and trained personnel be unavailable. Before performing any of these procedures, always thoroughly read all of the applicable text and carefully follow the instructions given. Always rigorously observe the **WARNINGS** provided.

Before you check anything in the engine compartment, always read and heed all

WARNINGS ⇒ ⚠ and ⇒ ⚠ in *Working in the engine compartment* on page 231.

WARNING

- Serious personal injury may occur as a result of improperly performed maintenance, adjustments or repairs.
- Always be extremely careful when working on the vehicle. Always follow commonly accepted safety practices and general common sense. Never risk personal injury.
- Do not attempt any of the maintenance, checks or repairs described on the following pages if you are not fully familiar with these or other procedures with respect to the vehicle, or are uncertain how to proceed.
- Do not do any work without the proper tools and equipment. Have the necessary work done by your authorized Audi dealer or another properly equipped and qualified workshop.
- The engine compartment of any motor vehicle is a potentially hazardous area. Never reach into the area around or touch the radiator fan. It is temperature controlled and can switch on suddenly - even when the engine is off. The radiator fan switches on automatically when the coolant reaches a certain temperature and will continue to run until the coolant temperature drops.
- Always switch off the ignition before anyone gets under the vehicle.
- Always support your vehicle with safety stands if it is necessary to work underneath the vehicle. The jack supplied with the vehicle is not adequate for this purpose and could collapse causing serious personal injury.
- If you must work underneath the vehicle with the wheels on the ground, always make sure the vehicle is on level ground, that the wheels are always securely blocked and that the engine cannot be started.

- Always make sure the transmission selector lever (automatic transmission) is in “P” (Park position) and the park brake is applied.



For the sake of the environment

- Changing the engine settings will adversely affect emission levels. This is detrimental to the environment and increases fuel consumption.
- Always observe environmental regulations when disposing of old engine oil, used brake fluid, dirty engine coolant, spent batteries or worn out tires.
- Undeployed airbag modules and pretensioners might be classified as Perchlorate Material -special handling may apply, see www.dtsc.ca.gov/hazardous-waste/perchlorate. When the vehicle or parts of the restraint system including airbag modules safety belts with pretensioners are scrapped, all applicable laws and regulations must be observed. Your authorized Audi dealer is familiar with these requirements and we recommend that you have your dealer perform this service for you.

Additional accessories, modifications and parts replacement

Additional accessories and parts replacement

Always consult an authorized Audi dealer before purchasing accessories.

Your vehicle incorporates the latest safety design features ensuring a high standard of active and passive safety.

This safety could be compromised by non-approved changes to the vehicle. For this reason, if parts have to be replaced, please observe the following points when installing additional accessories:

Approved Audi accessories and genuine Audi parts are available from authorized Audi dealers.

These dealers also have the necessary facilities, tools and trained specialists to install the parts and accessories properly.



WARNING

- Using the wrong spare parts or using non-approved accessories can cause damage to the vehicle and serious personal injury.
- Use only accessories expressly approved by Audi and genuine Audi spare parts
 - These parts and accessories have been specially designed to be used on your vehicle.
 - Never install accessories such as telephone cradles or beverage holders on airbag covers or within the airbag deployment zones. Doing so will increase the risk of injury if airbags are triggered in an accident!
 - Before you check anything in the engine compartment, always read and heed all WARNINGS ⇨ *page 231*.



Note

- If items other than genuine Audi spare parts, add-on equipment and accessory items are used or if repair work is not performed according to specified methods, this can result in severe damage to your vehicle's engine and body (such as corrosion) and adversely affect your vehicle's warranty.
- The innovative aluminium concept of your Audi A8 means that all servicing, repairs or other work on the vehicle body must be carried out exclusively by an Audi workshop.
- If emergency repairs must be performed elsewhere, have the vehicle examined by an authorized Audi dealer as soon as possible.
- The manufacturer cannot be held liable for damage which occurs due to failure to comply with these stipulations.

Technical Modifications

Our guidelines must be complied with when technical modifications are made.

Always consult an authorized Audi dealer **before** starting work on any modifications.

This will help ensure that vehicle function, performance and safety are not impaired ⇒ ⚠.

Attempting to work on electronic components and the software used with them can cause malfunctions. Because of the way electronic components are interconnected with each other, such malfunctions can also have an adverse affect on other systems that are not directly involved. This means that you risk both a substantial reduction in the operational safety of your vehicle and an increased wear of vehicle parts ⇒ ⚠.

Authorized Audi dealers will perform this work in a professional and competent manner or, in special cases, refer you to a professional company that specializes in such modifications.

WARNING

Improper repairs and modifications can change the way vehicle systems work and cause damage to the vehicle and serious personal injury.

Note

If emergency repairs must be performed elsewhere, have the vehicle examined by an authorized Audi dealer as soon as possible.

Declaration of Compliance, Telecommunication or Electronic Systems

Radio Frequency Devices and Radiocommunication Equipment User Manual Notice.

The manufacturer is not responsible for any radio or TV interference caused by unauthorized modifications to this equipment.

Devices

The following devices each comply with FCC Part 15.19, FCC 15.21 and RSS-Gen Issue 1:

- Adaptive cruise control
- Audi side assist
- Cell phone package
- Convenience key
- Electronic immobilizer
- Head phones
- HomeLink universal remote control
- Remote control key

FCC Part 15.19

This device complies with part 15 of the FCC Rules. Operation is subject to the following two conditions:

- (1) This device may not cause harmful interference, and
- (2) this device must accept any interference received, including interference that may cause undesired operation.

FCC Part 15.21

CAUTION:

Changes or modifications not expressly approved by the party responsible for compliance could void the user's authority to operate the equipment.

RSS-Gen Issue 1

Operation is subject to the following two conditions:

- (1) this device may not cause interference, and

(2) this device must accept any interference, including interference that may cause undesired operation of the device.

- A**
- A/C (automatic climate control) 80
- ABS
refer to Anti-lock braking system 199
- Accessories 294
- Adaptive air suspension/sport 110
- Adaptive cruise control 94
 Cleaning the sensor 217
 Messages 101
 Request for driver intervention 99
 Stop-and-go traffic 98
- Adaptive Light (defective) 22
- AdBlue 227
 Filling 229
 Messages in the instrument cluster display 228
- Adding
 Engine coolant 240
 Engine oil 237
 Windshield washer fluid 247
- Additives
 Engine oil 237
- Adjustable steering column 83
- Adjusting
 Air distribution (automatic climate control) 81
 Front seats 58
 Instrument illumination 51
 Steering column 83
 Temperature (automatic climate control) 81
- Airbag system 153, 172
 Advanced Airbag System 157
 Advanced Airbag System components . 160
 Care 166
 Children 178
 Child restraints 179
 Components (front airbags) 160
 Danger of fitting a child seat on the front passenger seat 155
 Disposal 166
 Front airbags 157, 158
 How do the front airbags work? 162
 How many airbags does my vehicle have? 160
 How the Advanced Airbag System components work together 161
- Important safety instructions on the knee airbag system 170
- Important things to know 153
- Knee airbags 168
- Monitoring 164
- PASSENGER AIR BAG OFF light 164
- Repairs 166
- Safety instructions 166
- Side airbags 171
- Side curtain airbags 174
- Warning/indicator lights 18
- Warning/Indicator lights 164
- Weight-sensing mat 178
- When must the system be inspected? . 164
- Aircraft
 Transporting your vehicle 287
- Alcantara
 Cleaning 219
- All Wheel Drive 204
 Winter tires 263
- Alternator
refer to Generator 16
- Ambience lighting 50
- Anti-freeze
refer to Engine coolant 239
- Anti-lock braking system 199
 Warning/indicator lights 18, 19
- Anti-slip regulation 199
 Warning/indicator lights 18
- Anti-theft systems
 Electronic immobilizer 32
- ASR
refer to Anti-slip regulation 199
- Audi braking guard
refer to Braking guard 94
- Audi drive select
refer to Drive select 110
- Audi Service Repair Manuals and Literature 292
- AUTO
 Automatic climate control 80
 Automatic headlights 46
- Auto Lock 33
- Automatic belt retractor 148
- Automatic climate control
 Air vents 81
 Automatic recirculation 82

Operation	80
Setup	82
Automatic climate control system	
synchronizing	81
Automatic transmission	116
Automatic transmission (tiptronic)	
Emergency mode	120
Kick-down	119
Manual shifting	119
Parking lock emergency release	121
Selector lever positions	116
Automatic wipers	53
Auto Safety Hotline	143
Average consumption	25
Average speed	25
Avoid damaging the vehicle	209

B

Battery	243
Charging	245
Important warnings	243
Location	243
low	204
Replacing the battery	246
State of charge	204
Winter operation	243
Working on the battery	243
Before driving	135
Blended gasoline	222
Blower (automatic climate control)	81
Booster seats	185
Brake fluid	
Changing the brake fluid	242
Checking the brake fluid level	242
What is the correct brake fluid level?	242
What should I do if the brake fluid warning light comes on?	242
Brake system	
Anti-lock braking system	19
Brake assist system	199
Brake booster	203
Brake fluid	242
Brake fluid specifications for refill and replacement	242
Brake light defective	22
Brake pads	207
Electromechanical parking brake	86

Fluid reservoir	242
How does moisture or road salt affect the brakes?	201
Warning/indicator lights	14
Worn brake pads symbol	20
braking guard	
Messages	101
Braking guard	94
Settings	101
Break-in period	207
Brake pads	207
Tires	207
Bulbs	282

C

California Proposition 65 Warning	232
Battery specific	245
Capacities	290
Engine oil	234
Carbon parts	
Cleaning	218, 219
Car carrier	
Transporting your vehicle	287
Care	216
Cargo area	
<i>refer to</i> Luggage compartment	141
Catalytic converter	208
Center armrest	
Cockpit	61
Rear	68
Central locking	33
Emergency locking	37
Certification	295
Changing a wheel	272
Changing engine oil	238
Checking	
Engine coolant level	240
Tire pressure	254
Child restraints	
Danger of using child restraints in the front seat	155
Where can I get additional information about child restraints and their use?	196
Child restraint system anchors	190

- Child safety 177
 - Convertible locking retractor 187
 - Guidance fixtures for lower anchorages 192
 - Important safety instructions for using child safety seats 180
 - Important things to know when driving with children 177
 - Tether anchors 194
 - Tether straps 194
 - Child safety lock
 - Rear doors (mechanical) 41
 - Rear doors (power) 41
 - Child safety seat
 - Unused safety belts on the rear seat . . 182
 - Child safety seats 183
 - Booster seats 185
 - Convertible child seats 184
 - Convertible locking retractor 187
 - How do I properly install a child safety seat in my vehicle? 180
 - Infant seats 183
 - Installing 187
 - Installing a child restraint using the LATCH system 193
 - LATCH system 193
 - Lower anchorages 191
 - Mounting and releasing the anchorage hook 193
 - Safety instructions 180
 - Cleaning 216
 - Climate controls 79
 - Climate control system
 - Supplementary heater 82
 - Clock 27
 - Closing
 - Panoramic sunroof 44
 - Sliding/tilting sunroof 43
 - Sun shade (panoramic sunroof) 45
 - Cold tire inflation pressure 252
 - Coming home 48
 - Compact spare tire 271
 - Compartments 75
 - Compass in the mirror 56
 - Compliance 295
 - Consumer Information 143, 292
 - Consumption (fuel) 25
 - Contacting NHTSA 143
 - Controls
 - Cleaning 218
 - Convenience key 35
 - Starting the engine 84
 - Stopping the engine (START ENGINE STOP button) 84
 - Switching the ignition on 84
 - Unlocking and locking vehicle 35
 - Convertible child safety seats 184
 - Convertible locking retractor
 - Activating 189
 - Deactivating 189
 - Using to secure a child safety seat 187, 189
 - Coolant
 - refer to* Engine coolant 239
 - Cooler 76
 - Cleaning 219
 - Operation 76
 - Cooling mode (automatic climate control) 80
 - Cruise control
 - Changing speed 92
 - Presetting your speed 92
 - Switching off 92
 - Switching on 91
 - Cupholder 75
 - Curve light 110
 - Cylinder on demand System 27
- D**
- Data recorder 199
 - Date display 27
 - Daytime running lights 46
 - Declaration of compliance
 - Adaptive cruise control 295
 - Audi side assist 295
 - Cell phone package 295
 - Convenience key 295
 - Electronic immobilizer 295
 - HomeLink universal remote control . . . 295
 - Remote control key 295
 - Decorative parts/trim
 - Cleaning 218
 - DEF
 - What does this mean when it appears in the trip odometer display? 27
 - Defective light bulb warning 22

- Defrosting (windows) 81
- Deluxe automatic climate control 80
- Determining correct load limit 257
- Diesel fuel 223
- Diesel particulate filter 21, 208
- Digital compass 56
- Dimensions 290
- Dimming the rearview mirror 56
- Displays
- Cleaning 218
- Distance 25
- Door/rear lid warning 24
- Doors
- Mechanical child safety lock 41
 - Power child safety lock 41
- Driver information system
- CD/radio display 24
 - Door/rear lid warning 24
 - Efficiency program 26
 - Exterior temperature display 24
 - On-board computer 25
- Driver seating position 136
- drive select
- adaptive air suspension/sport 110
 - Adaptive dampers 110
 - Curve light 110
 - Dynamic steering 110
 - Engine sound 110
 - Safety belt tensioner 110
 - Sport differential 110
- Drive select 110
- Driving safely 135
- Driving through water 209
- Driving time 25
- Duplicate key 31
- Dust filter
- refer to* Pollutant filter (automatic A/C system) 79
- Dynamic steering 22, 110
- E**
- Easy entry feature 83
- EDL
- refer to* Electronic differential lock 199
- Efficiency program 26
- Fuel economy messages 26
 - Other equipment 26
- Electrical accessories (sockets) 68, 74
- Electromechanical parking brake
- Emergency braking 88
 - Operation 86
 - Parking 87
 - Releasing and closing 86
 - Starting assist 87
 - Starting from rest 87
 - Starting off with a trailer 88
 - Warning/indicator lights 15
- Electronic differential lock 199
- Warning/indicator lights 18
- Electronic differential lock (EDL)
- Warning/indicator lights 19
- Electronic immobilizer 27, 32
- Electronic power control (EPC)
- warning/indicator light 20
- Electronic speed limiter 30
- Electronic Stabilization Control (ESC) 199
- Warning/indicator lights 18
- Emergency actuation
- Doors 37
 - Luggage compartment lid 40
 - Parking lock 121
 - Power sunroof 44
- Emergency braking 88
- Emergency flasher 47
- Warning/indicator lights 23
- Emergency operation
- Panoramic sunroof 45
 - Sun shade (roof) 45
- Emergency starting 283
- Emergency towing 285
- Emergency warning triangle 269
- Energy management 204
- Engine
- Compartment 233
 - Coolant 239
 - Data 291
 - Start-Stop-System 88
 - starting 84
 - Starting with jumper cables 283
 - Stopping 84

- Engine compartment 233
 Closing the hood 232
 Opening the hood 231
 Safety instructions 231
 Working in the engine compartment . . 231
- Engine coolant 239
 Adding coolant 240
 Checking the engine coolant level 240
 Expansion tank 240
 Malfunction symbol 16
 Radiator fan 241
 Temperature gauge 10
- Engine oil 234
 Adding 237
 Additives 237
 Changing 238
 Checking oil level 237
 Checking the engine oil level 236
 Consumption 237
 Indications and conditions requiring extra checking 236
 Indicator light 17
 Oil consumption 236
 Oil grades 234
 Pressure malfunction 17
 Recommended oil check intervals 236
 Sensor defective 21
 Specification and viscosity 234
- Engine sound 110
- Engine speed limitation 21
- Engine start-stop mode
refer to Start-Stop-System 90
- Entry assistance 64
- Environment
 Break-in period 207
 Catalytic converter 208
 Diesel particulate filter 208
 Disposing of your vehicle battery 246
 Driving at high speeds 210
 Driving to minimize pollution and noise 209
 Fuel 225
 Fuel economy 209
 Leaks under your vehicle 231
 Letting the vehicle stand and warm up . 210
 Proper disposal of drained brake fluid . 242
 Proper disposal of drained engine coolant 240
 Proper disposal of drained engine oil 237, 238
 Recycling used engine oil 237
 Unleaded fuel 222
 What should I do with an old battery? . 246
- EPC
refer to Electronic power control (EPC) . . 20
- ESC
refer to Electronic Stabilization Control (ESC) 199
- Event Data Recorder (EDR) 199
- Exhaust tail pipes
 Cleaning 218
- Expansion tank 240
- Exterior lighting 46
- Exterior mirrors
 Adjusting 55
 Dimming 56
 Heating 55
- Exterior temperature display 24
- F**
- Fastening
 Booster seats 185
 Convertible child safety seats 184
 Infant seats 183
- Floor mats 141
- Folding table 69
- Foot pedals 140
- For the sake of the environment
 Gasoline fumes and the environment . . 225
 Reducing engine noise by early upshifting 10
 Refuelling 225
 Saving fuel by early upshifting 10
- Four zone automatic climate control 80
- Front airbags
 Description 157
 How they work 162
- Frontal collisions and the laws of physics 146
- Front passenger seat adjustment 64
- Front seats 58
 Adjusting 137
 Child restraints in the front seat 155

- Fuel
- Additives 222
 - Blended gasoline 222
 - Current consumption 25
 - Economy messages (efficiency program) 26
 - Fuel filler flap emergency release 227
 - Fuel filler neck 224
 - Fuel gauge 11
 - Gasoline 222
 - Gasoline additives 223
 - Low fuel level symbol 21
 - Octane rating 222
 - Recommendation 222
 - Refuelling 225
 - Reserve 11
 - Tank capacity 11, 290
- Fuses
- Assignment 278
 - Replacing 278
- G**
- Garage door opener (HomeLink) 133
 - Garment hooks 76
 - Gas discharge lamps 282
- Gauges
- Engine coolant temperature 10
 - Fuel gauge 11
 - Speedometer 27
 - Tachometer 11
 - Trip odometer 27
- General illustration 8
 - Generator 16
 - Glossary of tire and loading terminology 249
 - Glove compartment (cooled) 75
 - Glow plug system
 - Indicator light 20
 - Gross Vehicle Weight Rating (GVWR) . . . 289
- H**
- Headlights
- Cleaning 217
 - Cleaning system 53
 - Defective 22
 - Headlight range control 22, 46
 - High beam assist 49
 - Washer reservoir 247
- Head restraints 65, 139
 - Adjusting 139
 - Heated
 - exterior mirrors 55
 - rear window 81
 - seats 81
 - windshield washer spray nozzles 53
 - Heating 79
 - Heavy clothing and safety belts 148
 - High beam 48
 - High voltage warning label 289
 - Hill descent control 119
 - HomeLink universal remote control 133
 - Hood (release lever) 231
 - Horn 8
 - How are child restraint system anchors related to child safety 190
 - How many airbags does my vehicle have? 160
 - How often should I check my tire pressures? 255
 - How safety belt pretensioners work 151
 - Hydroplaning 259
- I**
- Ignition
- Indicator lights 18
 - Switching on/off 84
- Immobilizer 27
 - Important things to do before driving . . 135
 - Improperly worn safety belts 151
 - Indicator lights
 - refer to* Warning/indicator lights 11
 - Infant seats 183
 - Installing child safety seats
 - Safety belts 187
 - Installing the upper tether strap on the anchorage 195
 - Instruments
 - Adjusting the lighting 51
 - Instruments and controls
 - General illustration 8
 - Instrument cluster 10
 - Interior lighting
 - Ambience lighting 50
 - Front and rear 50
 - Intermittent (windshield wipers) 53

- J**
- Jack 270
 - Jump-starting 283
 - Jumper cables 284
- K**
- Key 31
 - Battery replacement master key 32
 - Emergency key 31
 - Key not recognized 86
 - Key replacement 31
 - Master key 31
 - Mechanical key 32
 - Valet key 31
 - Kick-down (automatic transmission) 119
 - Knee airbags 168
 - Description 168
 - How they work 170
 - Important safety instructions 170
- L**
- Lane assist
 - Activating and deactivating 103
 - Cleaning the camera area 217
 - Description 103
 - Instrument cluster indicator light 103
 - Messages 104
 - Notes on instrument cluster display ... 103
 - Setting the steering wheel vibration ... 105
 - Setting the warning point 105
 - Lane Change Assistant
 - refer to Side assist* 106
 - LATCH 190
 - Description 191
 - Guidance fixtures for lower anchorages 192
 - Installing a child restraint 193
 - Location 191
 - Mounting and releasing the anchorage hook 193
 - Leather cleaning/protection 219
 - Leaving home 48
 - Lifting jack 275
 - Lifting vehicle 287
 - Light
 - Ambience lighting 50
 - Coming/Leaving home 48
 - Daytime running lights 46
 - Emergency flashers 47
 - Exterior lighting 46
 - Headlight range control 46
 - High beam 48
 - High beam assist 49
 - Low beam 46
 - Rear fog lights 46
 - Side marker lights 46
 - Turn signals 48
 - Light/rain sensor
 - Headlights 46
 - Intermittent (windshield wipers) 53
 - Sensor defective 22
 - Loading the roof rack 73
 - Locking
 - Luggage compartment lid 37
 - Power locking switch 36
 - Remote control 35
 - Using the key 36
 - Low beams 46
 - Lower universal anchorages (Canada) ... 190
 - Luggage compartment
 - Luggage compartment net 70
 - Pass-through with ski sack 71
 - Stowing luggage 141
 - Tie-downs 70
 - Luggage compartment lid
 - Automatic operation 38
 - Emergency release 40
 - Movement-activated opening 40
 - Opening and closing 37
 - Lumbar support
 - Front seats 60
 - Rear seats 61
- M**
- Maintenance 292
 - Malfunction Indicator Lamp (MIL) .. 20, 29
 - Massage function
 - Front seats 60
 - Rear seats 61
 - Reclining rear seat 64
 - Matte finish paint cleaning 216
 - Mechanical key 32

- Mirrors
- Adjusting the exterior mirrors 55
 - Compass 56
 - dimming 56
 - Vanity mirrors 51, 52
- Monitoring the Advanced Airbag System 164
- Multifunction steering wheel 25
- N**
- Natural leather
- Cleaning 219
- New tires and wheels 259
- NHTSA
- Contacting 143
- Night vision assistant 113
- Cleaning camera lenses 217
- Nitrogen oxide (NOx) catalytic converter
- refer to* AdBlue 227
- Number of seats 145
- O**
- Occupant seating positions 136
- Octane rating 222
- Odometer 27
- OFF (automatic climate control) 80
- Oil
- refer to* Engine oil 234
- On-board computer 25
- On-Board Diagnostic System (OBD)
- Data Link Connector (DLC) 29
 - Electronic speed limiter 30
 - Malfunction Indicator Lamp (MIL) 29
- Open door/hood/rear lid warning 29
- Opening
- Hood 231
 - Luggage compartment lid 38, 40
 - Panoramic sunroof 44
 - Power windows 41
 - Sliding/tilting sunroof 43
 - Sun shades 45, 52
- Operate your vehicle economically and minimize pollution 209
- Other equipment (efficiency program) . . . 26
- Outside mirrors
- refer to* Exterior mirrors 55
- P**
- Paint damage 218
- Paint No. 289
- Panoramic sunroof 44
- Sun shade 45
- Parking 87
- Valet parking 42
- Parking brake 86
- also refer to* Electromechanical parking brake 86
- Parking system
- Adjusting the display/warning tone . . . 132
 - Cleaning sensors/camera lenses 217
 - Cleaning the rear view camera 123
 - Malfunction 132
 - Peripheral cameras 127
 - Trailer hitch 132
- Parking systems 122
- Particle filter
- refer to* Diesel particulate filter 21
- Parts replacement 294
- Pass-through with ski sack 71
- PASSENGER AIR BAG OFF light 164
- Passenger protection 197
- Passive safety system 135
- Pedals 140
- Physical principles of a frontal collision . 146
- Plastic parts
- Cleaning 218
- Polishing 218
- Pollen filter
- refer to* Pollutant filter (automatic A/C system) 79
- Pollutant filter (automatic A/C system) . . 79
- Power locking system 33
- Locking/unlocking the vehicle from inside 36
 - Luggage compartment lid 37
 - Selective unlock feature 34
 - Settings 34
 - Unlocking and locking vehicle 35
- Power seat adjustment
- Front seats 59
 - Rear seats 61
- Power steering (servotronic) 203

- Power windows 41
 malfunction 42
- Pregnant women
 Special considerations when wearing a
 safety belt 150
- pre sense 197
- Preventative passenger protection 197
- Programming the HomeLink universal re-
 mote control 133
- Proper occupant seating positions 136
- Proper safety belt position 149
- Proper seating position
 Front passenger 137
 Occupants 136
 Rear passengers 138
- Protecting 218
- Q**
- quattro
refer to All Wheel Drive 204
- Question
 What happens to unbelted occupants? 146
 Why safety belts? 145
- R**
- Radiator fan 241
- Radio clock 27
- Rain/light sensor
 Headlights 46
 Intermittent (windshield wipers) 53
 Sensor defective 22
- Range (fuel level) 25
- Reading lights 50
- Rear fog lights 46
- Rear lid
 Escape handle 269
- Rear light
 Defective 22
- Rear seats
 Adjusting individual seats 61
 Entry assistance 64
 Front passenger seat adjustment 64
 Reclining rear seat 63
- Rear view mirror 56
- Rear window heating 81
- Recirculation mode (automatic climate
 control) 80
- Reclining rear seat 63
- Refuelling 225
- Remote control
 Garage door opener (HomeLink) 133
 Massage function 64
 Unlocking and locking 35
- Remote luggage compartment lid release 37
- Repair manuals 292
- Repairs
 Airbag system 166
- Replacing
 Fuses 278
 Light bulbs 282
 Tires and wheels 260
 Windshield wiper blades 54
- Reporting Safety Defects 143
- Reset button 27
- Retractor 148
- Reverse 116
- Rims
 Cleaning 217
- Roof rack 72
 Loading 73
 Roof weight 73
- S**
- SAFE 27
- Safe driving habits 135
- Safety belt position 149
 Safety belts worn by pregnant women . 150
- Safety belt pretensioner 151
 Service and disposal 152
- Safety belt pretensioners
 Pre sense 197
- Safety belts 148
 Adjusting 150
 Cleaning 218
 Danger to passengers who do not wear a
 safety belt 146
 Fastening 148
 Improperly worn 151
 Not worn 146
 Safety belt position 149
 Safety instructions 148

- Securing child safety seats 187
- Special considerations for pregnant women 150
- Unfastening 150
- Warning/indicator light 145
- Warning light 16
- Why YOU MUST wear them 145
- Worn properly 147
- Safety belt tensioner
 - drive select 110
- Safety belt warning light 145
- Safety compliance sticker 289
- Safety equipment 135
- Safety features for occupant restraint and protection 135
- Safety guidelines
 - Seat adjustment 58
- Safety instructions
 - Engine compartment 231
 - for side curtain airbags 175
 - for using child safety seats 180
 - for using safety belts 148
 - Monitoring the Advanced Airbag System 166
- Safety systems
 - Warning/indicator lights 18
- Seat adjustment
 - Controls (front seats) 59
 - Controls (rear seats) 61
 - Driver's seat 58
 - Front passenger's seat 59
 - Front seats 58
 - Head restraints 65, 139
 - Reclining rear seat 62
 - Safety guidelines 58
- Seat belts
 - Why YOU MUST wear them 145
- Seat covers
 - Cleaning 219
- Seat heating/ventilation 81
- Seating position
 - Driver 136
 - Front passenger 137
 - How to adjust the front seats 137
 - Incorrect seat position 139
 - Occupants 136
 - Rear passengers 138
- Seat memory 66
- Seats
 - Comfort seat side view 67
 - Seat symmetry 67
- Seats (number) 145
- Selective catalytic reduction
 - refer to AdBlue* 227
- Selective unlock feature 34
- Selector lever 116
- Service and disposal
 - Safety belt pretensioner 152
- Service interval display 28
- Service position
 - refer to Windshield wipers* 54
- Servotronic (power steering system) 203
- Shift paddles 119
- Ship (transporting your vehicle) 287
- Shutting down vehicle 209
- Side airbags
 - Description 171
 - How they work 172
- Side assist 106
 - Activating and deactivating 108
 - Adjusting the brightness 108
 - Cleaning the sensors 217
 - Sensor range 107
- Side curtain airbags 174
 - Description 174
 - How they work 175
 - Safety instructions 175
- Side marker lights 46
- Ski sack
 - refer to Pass-through with ski sack* 71
- Sliding/tilting sunroof
 - Emergency closing 44
 - Emergency operation 45
 - Opening and closing 43
 - Panoramic sunroof 44
- Snow chains 264
- Sockets 68, 74
- Solar operation (automatic climate control) 82
- Sources of information about child restraints and their use 196
- Space-saving spare tire 271

- Spare tire
refer to Compact spare tire 271
- Spare wheel 272
- Speedometer 27
- Speed rating letter code 260
- Speed warning system 91
- Sport differential 110
 Indicator light 23
- Start-Stop-System 88
 Engine does not switched off 89
 Engine starts automatically 89
 Indicator lights 89
 Messages 91
 Starting/stopping the engine 89
 switching off/on 90
- START ENGINE STOP button 84
- Starting from rest 87
- Starting off with a trailer 88
- Starting the engine 84
- Steering wheel
 Adjusting steering column 83
 Easy entry feature 83
 Indicator light 17, 22
 Shift paddles 119
 Steering wheel heating 82
- Steps for determining correct load limit 257
- Stopping the engine 84
- Storage 75
- Sunroof 43
- Sun shades
 Emergency closing (roof) 45
 Panoramic sunroof 45
 Rear doors 52
 Rear window 52
- Sun visors 51
- Symbols
refer to Warning/Indicator lights 11
- T**
- Tachometer 11, 24
- Tail lights
 Cleaning 217
- TDI clean diesel
refer to AdBlue 227
- Technical data 289
- Technical modifications 295
- Temperature display 24
- Tether anchors 194
- Tether strap 194
- Textiles
 Cleaning 219
- The first 1,000 miles (1,500 km) and afterwards 207
- Tie-downs 70, 142
- Tips for the environment
 Saving fuel 73
- tiptronic (automatic transmission) 116
- Tire pressure 254
- Tire pressure monitoring system 266
 Loss of air pressure 267
 Malfunction 267
 Resetting tire pressures 268
- Tires 248
 Service life 258
 speed rating letter code 260
 Tire manufacturing date 260
 Tire specifications 260
 Tread depth 258
 Uniform tire quality grading 262
 Winter tires 263
- Tires and vehicle load limits 256
- Tires and wheels
 Checking tire pressure 254
 Cold tire inflation pressure 252
 Dimensions 259
 General notes 248
 Glossary of tire and loading terminology 249
 Low aspect ratio tires 265
 New tires and wheels 259
 Replacing 260
 Snow chains 264
 Tires and vehicle load limits 256
 Wheel bolts 265
 Winter tires 263
- Tire service life 258
- Tools 270
- Torn or frayed safety belts 148
- Towing
 Tow truck procedures 285
- TPMS
 Tire pressure monitoring system 267

- Trailer towing 212
 Operating instructions 212
 Parking system 132
 Technical requirements 212, 213
 Trailer towing tips 214
- Train (transporting your vehicle) 287
- Transmission 116
- Transmission malfunction (indicator light) 120
- Transport Canada 143
- Transporting your vehicle 287
- Tread Wear Indicator (TWI) 258
- Trip odometer 27
 What does it mean when DEF appears in the trip odometer display? 27
- Trunk
refer to Luggage compartment lid 37
- Trunk escape handle 269
- Turn signals 48
 Warning/indicator lights 23
- U**
- Unfastening safety belts 150
- Unidirectional tires 248
- Uniform tire quality grading 262
- Unlocking
 Luggage compartment lid 37
 Power locking switch 36
 Remote control 35
 Using the key 36
- V**
- Valet parking 42
- Vanity mirrors 51, 52
- Vehicle
 care/cleaning 216
- Vehicle electrical system 16
- Vehicle identification label 289
- Vehicle Identification Number (VIN) 289
- Vehicle jack 270, 275
- Vehicle literature 5
- Vehicle shutt-down 209
- Vehicle transport 287
- Ventilation 79
- Vinyl
 Cleaning 219
- W**
- Warning/indicator lights 11
 Airbag system 18
 Anti-lock braking system (ABS) 19
 Brake system 14
 Electromechanical parking brake 15
 Electronic power control 20
 Electronic Stabilization Control (ESC) ... 18
 Generator 16
 Glow plug system 20
 Instrument cluster 10
 Malfunction Indicator Lamp (MIL) 20
 Safety belt 16
 Turn signals 23
- Warning/Indicator lights
 Airbag system 164
 Dynamic steering 22
 PASSENGER AIR BAG OFF 164
- Warranty coverages 292
- Washer reservoir 247
- Wear indicator 258
- Weights 289
- What happens if you wear your safety belt too loose? 149
- What happens to unbelted occupants? .. 146
- What impairs driving safety? 136
- What should I do after changing a wheel? 255
- What should I do after replacing wheels? 255
- Wheel bolts
 Torque 265
- Wheels 248
 Checking tire pressure 254
 Cleaning 217
 Cold tire inflation pressure 252
 General notes 248
 Glossary of tire and loading terminology 249
 New tires and wheels 259
 Tires and vehicle load limits 256
- When must a safety belt be replaced? .. 148
- When must the airbag system be inspected? 164

- When should I adjust the tire pressures? 255
- When should I check the tire pressures? . 255
- Where are lower anchorages located? . . . 191
- Where can I find the tire pressures for my car? 254
- Why safety belts? 145, 146
- Windows
- Cleaning/removing ice 218
 - defrosting 81
- Windshield
- Cleaning 53
 - defrosting 81
- Windshield washer system 53
- Washer fluid level 21
 - Washer reservoir 247
- Windshield wipers
- Cleaning 54
 - Folding up 54
 - Indicator light 22
 - Replacing windshield wiper blades 54
 - Switching on/off 53
- Winter operation
- Battery 243
 - Car washes 216
 - Cooling system 239
 - Defrosting windows 81
 - Removing ice from windows 218
 - Seat heating 81
 - Steering wheel heating 82
 - Tires 204
- Winter tires 263
- All-wheel drive 263
- X**
- Xenon-Lights 282
- Xenon plus headlights 46

It has always been Audi's policy to continuously improve its products. Audi, therefore, reserves the right to make changes in design and specifications, and to make additions or improvements in its products, without incurring any obligation to install them on products previously manufactured.

Text, illustrations and specifications in this manual are based on the most up-to-date information available at the time of printing.

All rights reserved. May not be reproduced or translated in whole or in part without the

written consent of AUDI AG. Specifications are subject to change without notice.

Editorial deadline: 03/19/2013



For the sake of the environment

Printed on environmentally friendly paper
(bleached without chlorine, recyclable).

Printed in Germany

© 2013 AUDI AG

Owner's Manual
2014 Audi A8
2014 Audi S8
Englisch Nordamerika 05.2013
142.561.4H0.21



1425614H021

www.audi.com