

Contents

A-Z

THE BMW i3.
OWNER'S MANUAL.

BMW i. 



BMW i SUSTAINABILITY.

AUTOMOBILITY.
REINVENTED.

THE SUSTAINABLE PRODUCT LIFE CYCLE OF BMW i.



01. DEVELOPMENT

- Redefine design principles for purpose-built e-mobility.
- Reshape aerodynamics for less drag.
- Replace traditional materials with recycled and renewable materials.

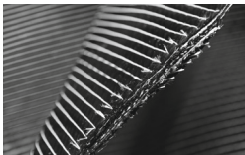
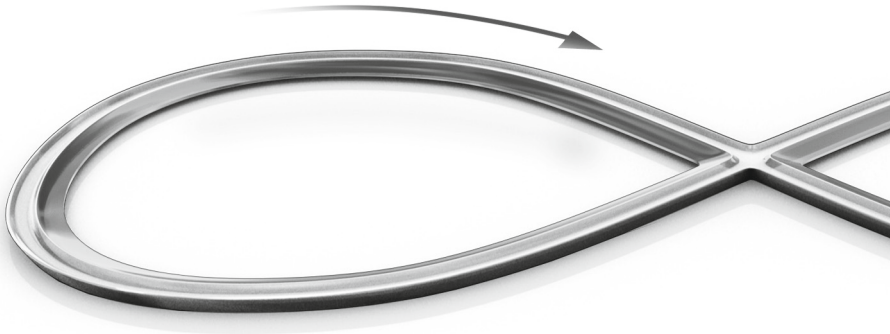

04. RECYCLING

- Retain used batteries as temporary storage units, e.g. for solar energy.
- Recycle carbon fibers by returning them to the production process.



03. UTILIZATION

- Recharge battery with innovative BMW eDrive technology.
- Receive power from clean energy producers for zero emission driving.
- Reduce CO₂ emissions by 50% throughout the product life cycle by using energy from renewable sources.



02. PRODUCTION

- Use clean electric power for BMW i plants.
- Reduce energy consumption in BMW i production.

01. DEVELOPMENT

FOR OVER THREE QUARTERS OF A CENTURY, THE BASIC IDEA BEHIND THE CAR WAS LEFT UNTOUCHED.

Until now. Today, the BMW i3 introduces a wealth of new ways to create the ultimate sustainable electric car. One key innovation is LifeDrive: the first serial production passenger cell made of light and extremely robust carbon fiber. It substantially reduces the weight of the vehicle for maximum electric range. Moreover, streamflow aerodynamics reduce drag and energy consumption.

The interior of the BMW i3 features natural-fiber based raw materials in the instrument panel and door trim surfaces. Textiles for the seats are made of up to 100% recycled materials. The leather components are tanned with natural olive leaf extract, which gives the leather a unique, fresh scent. The interior wood panels are made of open-pore eucalyptus wood. All wood is sourced from responsible forestry and certified by the Forest Stewardship Council® (FSC®).

Innovation is also built into the BMW i3 product development process itself: To ensure a truly sustainable product, measurable targets were already set in the early strategic phase of development to define environmental guidelines for the entire product life cycle – from the sourcing of raw materials to production, utilization and recycling. These were agreed to and monitored throughout the development phase of the vehicle. The life cycle assessment process and the results have been certified by a third party according to ISO 14040/14044. Further details can be found online at bmw-i.com.

The Life module is made of ultra-light carbon fiber.



30%
lighter than aluminum.

50%
lighter than steel.

The interior of the BMW i3 includes a variety of premium-quality, sustainable materials. Approximately 25% of the thermoplastics used are composed of recyclates or have been replaced by renewable materials.

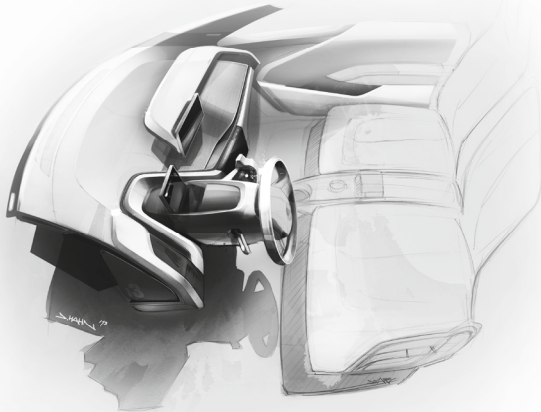

The mark of
responsible forestry
FSC® N002012

02. PRODUCTION

THE BMW i3: FORGED BY THE POWER OF WIND AND WATER.

The BMW i3 not only produces zero emissions while driving; all electricity that goes into its production in Leipzig is generated from renewables. BMW factories have been leading the way in sustainable production for a long time now, but BMW i has gone even further and significantly improved its facilities. The BMW i factory in Leipzig produces its own renewable energy – right on the premises – and operates on 100% clean electric power at zero emissions. It also consumes significantly less resources.

And consider the unique approach to carbon fiber production: It has been located in Moses Lake, USA, so that all operations can be powered completely by renewable energy from the numerous hydro-electric plants nearby.

For BMW i, sustainable production is not only an environmental consideration but also a social one, creating future-proof job profiles and training BMW i's suppliers to comply with advanced sustainability standards.

-50%

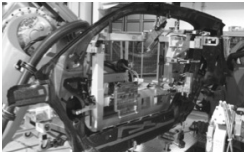

energy input

-70%



water consumption

100%



renewable energy

Energy and resource
consumption per
BMW i3 produced*

* compared to the industry-
leading BMW average

03. UTILIZATION

THE ORIGIN OF EMISSION-FREE DRIVING: POWER FROM RENEWABLE RESOURCES.

With zero local emissions while driving, the BMW i3 helps reduce air pollution in urban areas. When charged with clean power – generated from renewables – the positive impact is greater still. This is because, throughout the entire product life cycle, driving the new BMW i3 on energy from renewable sources can potentially reduce emissions (CO₂ equivalents) by up to 50%, when compared to a highly efficient vehicle of the same class with a combustion engine. That's why BMW i recommends clean energy producers, to help make an even bigger difference. Further details can be found online at bmw-i.com/sustainability.

As if that weren't enough, the innovative eDrive technology of the BMW i3 also features all sorts of efficiency enhancers: from state-of-the-art brake energy recuperation to range-increasing ECO PRO+ driving mode, which can boost the driving range by up to 40km at the touch of a button.

In terms of its performance throughout the entire product life cycle – from the sourcing of raw materials to production, use and recycling – how does the BMW i3 compare to a vehicle with a high-efficiency combustion engine?



50%

fewer CO₂ equivalents when driving on electricity from renewable sources.

30%

fewer CO₂ equivalents when driving with EU-25 or comparable energy mixes.

04. RECYCLING

AT BMW i WE NOT ONLY PIONEER NEW MATERIALS, WE ALSO TAKE CARE OF THEIR RECYCLING.

Recycling is a given at BMW i. Production residues from carbon fiber production, carbon components and body parts, for instance, are valuable materials. That's why they are either reused as secondary raw materials for the in-house BMW i production cycle or recycled for other automotive or non-automotive applications. And the early production stage of a BMW i3 marks a first for the automotive industry – the first time recycled carbon fiber is being used for a vehicle passenger cell. Together with partners, BMW i is pioneering closed loops for up to 100% of carbon fiber from production residues or end-of-life vehicles.

BMW i is also branching out in new directions when it comes to the recycling of other components and materials. For example, there are many possible ways to reuse the high-capacity BMW i lithium ion battery pack. A very simple and effective one is as temporary energy storage for solar power or wind energy to make renewably produced energy available when it is needed.

100%



of used battery packs could, for example, be reused as temporary storage units for solar power equipment and wind energy systems.

To find out more about the sustainability philosophy behind your BMW i, please visit: [**bmw-i.com/sustainability**](http://bmw-i.com/sustainability)

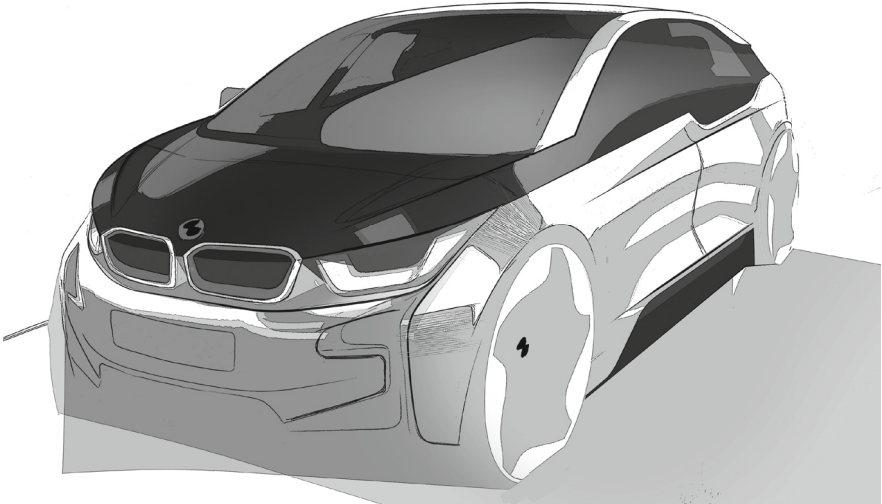

i3 Owner's Manual for Vehicle

Thank you for choosing a BMW i.

The more familiar you are with your vehicle, the better control you will have on the road. We therefore strongly suggest:

Read this Owner's Handbook before starting off in your new BMW i. Also use the Integrated Owner's Manual in your vehicle. It contains important information on vehicle operation that will help you make full use of the technical features available in your BMW i. The manual also contains information designed to enhance operating reliability and road safety, and to contribute to maintaining the value of your BMW i.

Any updates made after the editorial deadline can be found in the appendix of the Owner's Handbook for Vehicle.

We wish you a safe and enjoyable ride.

BMW AG

© 2014 Bayerische Motoren Werke
Aktiengesellschaft
Munich, Germany

Reprinting, including excerpts, only with the written
consent of BMW AG, Munich.

US English X/14, 11 14 490

Printed on environmentally friendly paper, bleached
without chlorine, suitable for recycling.

Contents

The fastest way to find information on a particular topic or item is by using the index, refer to page 208.

6 Notes

At a glance

- 14 Cockpit
- 18 iDrive
- 26 Voice activation system
- 29 Integrated Owner's Manual in the vehicle
- 31 BMW eDRIVE

Controls

- 36 Opening and closing
- 51 Adjusting
- 58 Transporting children safely
- 62 Driving
- 74 Displays
- 89 Lights
- 92 Safety
- 106 Driving stability control systems
- 109 Driving comfort
- 127 Climate control
- 134 Interior equipment
- 138 Storage compartments

Driving tips

- 144 Things to remember when driving
- 148 Loading
- 150 Increase range

Mobility

- 156 Charging vehicle
- 165 Refueling
- 168 Fuel
- 170 Wheels and tires
- 179 Under the hood
- 181 Engine oil
- 183 Coolant
- 185 Maintenance
- 187 Replacing components
- 193 Breakdown assistance
- 198 Care

Reference

- 204 Technical data
- 206 Appendix
- 208 Everything from A to Z

Notes

The special features of your BMW i

High-voltage system

Your BMW i is an electric vehicle. The vehicle features a high-voltage system that consists of an electric motor and a high-voltage battery among other things. Optionally, the vehicle has a combustion engine that generates electrical energy via a generator and thereby increases the range. This combustion engine is called the Range Extender.

Carbon body

The vehicle consists of two different functional units: the drive module made from aluminum and the life module made from carbon fiber reinforced plastic (carbon).

Using this Owner's Manual

Orientation

The fastest way to find information on a particular topic is by using the index.

An initial overview of the vehicle is provided in the first chapter.

Updates made after the editorial deadline

Any updates made after the editorial deadline can be found in the appendix of the printed Owner's Handbook for Vehicle.

User's manual for Navigation, Entertainment, Communication

The topics Navigation, Entertainment, Communication and the short commands of the voice activation system can be retrieved on the Control Display via the Integrated Owner's Handbook.

Symbols

 Indicates precautions that must be followed precisely in order to avoid the possibility of personal injury and serious damage to the vehicle.

◀ Marks the end of a specific item of information.

 Refers to measures that can be taken to help protect the environment.

"..." Identifies display texts in vehicle used to select individual functions.

>...< Verbal instructions to use with the voice activation system.

»...« Identifies the answers generated by the voice activation system.

Symbols on vehicle components

 Indicates that you should consult the relevant section of this Owner's Manual for information on a particular part or assembly.

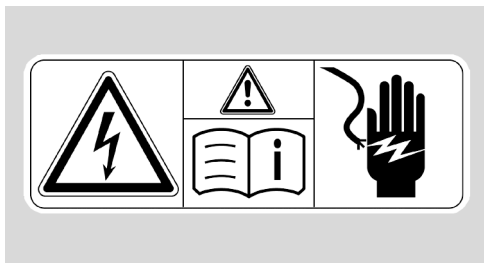

Indicates, on certain parts or assemblies, that incorrect use of high-voltage equipment or of orange-colored high-voltage components results in the risk of life-threatening injury from electric shock.

Vehicle features and options

This Owner's Manual describes all models and all standard, country-specific and optional

equipment that is offered in the model series. Therefore, in this Owner's Manual, we also describe and illustrate features that are not available in your vehicle, e.g., because of the selected optional features or the country-specific version.

This also applies to safety-related functions and systems.

On right-hand drive vehicles, some controls are arranged differently from what is shown in the illustrations.

Status of the Owner's Manual

Basic information

The manufacturer of your vehicle pursues a policy of constant development that is conceived to ensure that our vehicles continue to embody the highest quality and safety standards. In rare cases, therefore, the features described in this Owner's Manual may differ from those in your vehicle.

Updates made after the editorial deadline

Any updates made after the editorial deadline can be found in the appendix of the printed Owner's Handbook for Vehicle.

For your own safety

Warranty

Your vehicle is technically configured for the operating conditions and registration requirements applying in the country of first delivery - homologation. If your vehicle is to be operated in a different country it might be necessary to adapt your vehicle to potentially differing operating conditions and permit requirements. If your vehicle does not comply with the homologation requirements in a certain country you cannot lodge warranty claims for your vehicle

there. Further information can be obtained from your Service Centre.

Working on the vehicle, maintenance and repairs

Advanced technology, especially the use of high-performance high-voltage electronics and modern materials such as carbon, requires special knowledge when making modifications to and working on the vehicle, as well as customized maintenance and repair work.

Modifications and work on the vehicle, especially maintenance and repairs to the high-voltage system and carbon body as well as the retrofitting of accessories, may only be carried out by an authorized BMW i service center or one that operates according to BMW i specifications with personnel trained accordingly.



Body work and working on the high-voltage system

Do not perform any modifications or work on the vehicle, especially maintenance and repair work on the high-voltage system and the carbon body and avoid retrofitting accessories.

If work is not carried out properly, there is the risk of fire and fatal injury from electrocution due to the high-voltage system's high voltage.

Modifications and work on the vehicle may only be carried out by an authorized BMW i service center or one that operates according to BMW i specifications with personnel trained accordingly. ◀

Parts and accessories

BMW recommends using parts and accessories approved by BMW for this purpose.

Your BMW center is the right contact for genuine BMW parts and accessories, other products approved by BMW and related qualified advice.

BMW has tested these products for safety and suitability in relation to BMW vehicles.

BMW can assume responsibility for them. However, we cannot assume any responsibility whatsoever for parts and accessories that have not been specifically approved by BMW.

BMW cannot evaluate whether each individual product from another manufacturer can be used with BMW vehicles without presenting a safety hazard. This guarantee is also not applicable when country-specific government approval has been granted. Testing of this kind may fail to embrace the entire range of potential operating conditions to which components might be exposed on BMW vehicles. Such products could conceivably fail to comply with BMW's own stringent quality standards.

California Proposition 65 Warning

California laws require us to state the following warning:

Engine exhaust and a wide variety of automobile components and parts, including components found in the interior furnishings in a vehicle, contain or emit chemicals known to the State of California to cause cancer and birth defects and reproductive harm. In addition, certain fluids contained in vehicles and certain products of component wear contain or emit chemicals known to the State of California to cause cancer and birth defects or other reproductive harm. Battery posts, terminals and related accessories contain lead and lead compounds. Wash your hands after handling. Used engine oil contains chemicals that have caused

cancer in laboratory animals. Always protect your skin by washing thoroughly with soap and water.

Service and warranty

We recommend that you read this publication thoroughly. Your vehicle is covered by the following warranties:

- ▷ New Vehicle Limited Warranty.
- ▷ Rust Perforation Limited Warranty.
- ▷ Federal Emissions System Defect Warranty.
- ▷ Federal Emissions Performance Warranty.
- ▷ California Emission Control System Limited Warranty.

Detailed information about these warranties is listed in the Service and Warranty Information Booklet for US models or in the Warranty and Service Guide Booklet for Canadian models.

Your vehicle has been specifically adapted and designed to meet the particular operating conditions and homologation requirements in your country and continental region in order to deliver the full driving pleasure while the vehicle is operated under those conditions. If you wish to operate your vehicle in another country or region, you may be required to adapt your vehicle to meet different prevailing operating conditions and homologation requirements. You should also be aware of any applicable warranty limitations or exclusions for such country or region. In such case, please contact Customer Relations for further information.

Maintenance

Maintain the vehicle regularly to sustain the road safety, operational reliability and the New Vehicle Limited Warranty.

Specifications for required maintenance measures:

- ▷ BMW Maintenance system
- ▷ Service and Warranty Information Booklet for US models

- ▷ Warranty and Service Guide Booklet for Canadian models

If the vehicle is not maintained according to these specifications, this could result in serious damage to the vehicle. Such damage is not covered by the BMW New Vehicle Limited Warranty.

Data memory

Many electronic components on your vehicle are equipped with data memories that temporarily or permanently store technical information about the condition of the vehicle, events and faults. This technical information generally records the state of a component, a module, a system or the environment:

- ▷ Operating mode of system components, fill levels for instance.
- ▷ Status messages for the vehicle and from its individual components, e.g., wheel rotation speed/vehicle speed, deceleration, transverse acceleration.
- ▷ Malfunctions and faults in important system components, e.g., lights and brakes.
- ▷ Responses by the vehicle to special situations such as airbag deployment or engaging the stability control system.
- ▷ Ambient conditions, such as temperature.

This data is purely technical in nature and is used to detect and correct faults and to optimize vehicle functions. Motion profiles over routes traveled cannot be created from this data. When service offerings are used, e.g., repair services, service processes, warranty claims, quality assurance, this technical information can be read out from the event and fault memories by the service personnel, including the manufacturer, using special diagnostic tools. You can obtain further information there if you need it. After an error is corrected, the information in the fault memory is deleted or overwritten on a continuous basis.

With the vehicle in use there are situations where you can associate these technical data with individuals if combined with other information, e.g., an accident report, damage to the vehicle, eye witness accounts — possibly with the assistance of an expert.

Additional functions that are contractually agreed with the customer - such as vehicle emergency locating - you can transmit certain vehicle data from the vehicle.

Event Data Recorder EDR

This vehicle is equipped with an event data recorder EDR. The main purpose of an EDR is to record, in certain crash or near crash-like situations, such as an air bag deployment or hitting a road obstacle, data that will assist in understanding how a vehicle's systems performed. The EDR is designed to record data related to vehicle dynamics and safety systems for a short period of time, typically 30 seconds or less.

The EDR in this vehicle is designed to record such data as:

- ▷ How various systems in your vehicle were operating.
- ▷ Whether or not the driver and passenger safety belts were fastened.
- ▷ How far, if at all, the driver was depressing the accelerator and/or brake pedal.
- ▷ How fast the vehicle was traveling.

These data can help provide a better understanding of the circumstances in which crashes and injuries occur.

EDR data are recorded by your vehicle only if a nontrivial crash situation occurs; no data are recorded by the EDR under normal driving conditions and no personal data, e.g., name, gender, age, and crash location, are recorded.

However, other parties, such as law enforcement, could combine the EDR data with the

type of personally identifying data routinely acquired during a crash investigation.

To read data recorded by an EDR, special equipment is required, and access to the vehicle or the EDR is needed. In addition to the vehicle manufacturer, other parties, such as law enforcement, that have the special equipment, can read the information if they have access to the vehicle or the EDR.

Vehicle identification number

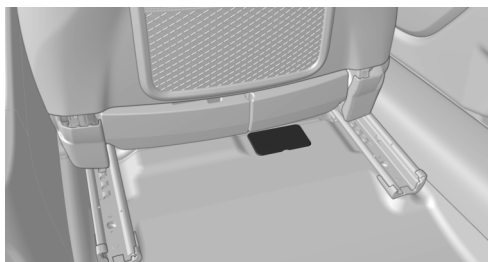

The vehicle identification number can be found under a cover under the front passenger seat.

The vehicle identification number can also be found behind the windshield.

Reporting safety defects

For US customers

The following only applies to vehicles owned and operated in the US.

If you believe that your vehicle has a defect which could cause a crash or could cause injury or death, you should immediately inform the National Highway Traffic Safety Administration NHTSA, in addition to notifying BMW of North America, LLC, P.O. Box 1227, Westwood, New Jersey 07675-1227, Telephone 1-800-831-1117.

If NHTSA receives similar complaints, it may open an investigation, and if it finds that a

safety defect exists in a group of vehicles, it may order a recall and remedy campaign.

However, NHTSA cannot become involved in individual problems between you, your dealer, or BMW of North America, LLC.

To contact NHTSA, you may call the Vehicle Safety Hotline toll-free at 1-888-327-4236 (TTY: 1-800-424-9153); go to <http://www.safercar.gov>; or write to: Administrator, NHTSA, 400 Seventh Street, SW., Washington, DC 20590. You can also obtain other information about motor vehicle safety from <http://www.safercar.gov>.

For Canadian customers

Canadian customers who wish to report a safety-related defect to Transport Canada, Defect Investigations and Recalls, may call the toll-free hotline 1-800-333-0510. You can also obtain other information about motor vehicle safety from <http://www.tc.gc.ca/roadsafety>.



At a glance

These overviews of buttons, switches and displays are intended to familiarize you with your vehicle. You will also become quickly acquainted with the available control concepts and options.

Cockpit

Vehicle features and options

This chapter describes all standard, country-specific and optional features offered with the series. It also describes features that are not

necessarily available in your car, e. g., due to the selected options or country versions. This also applies to safety-related functions and systems.

All around the steering wheel

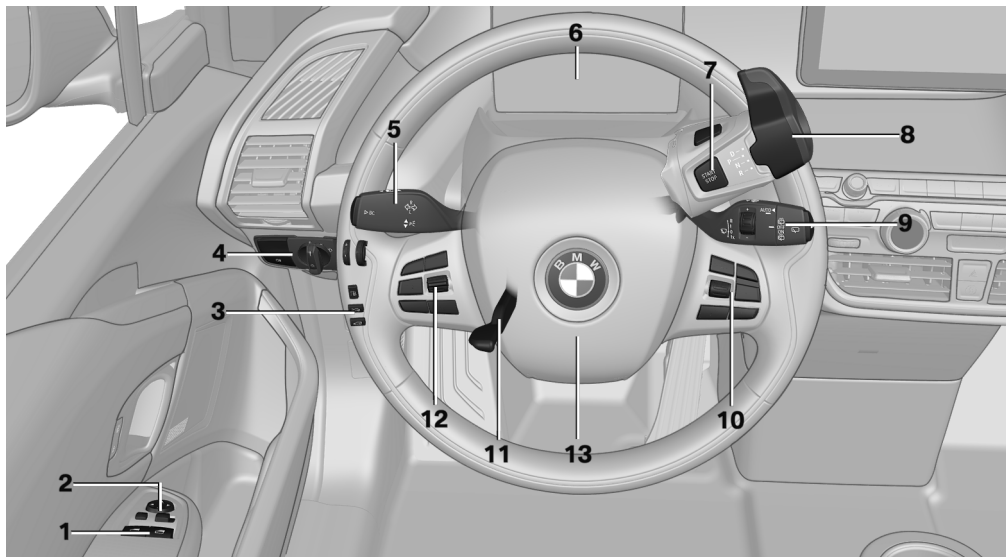

- 1 Power windows 48
- 2 Exterior mirror operation 55
- 3 Unlocking hood 42
Unlock tailgate 43
With Range Extender: vent fuel tank 165

4 Lights



Parking lights 89



Low beams 89



Automatic headlight control 90

Daytime running lights 90



Instrument lighting 90















5 Left steering column stalk



Turn signal 69





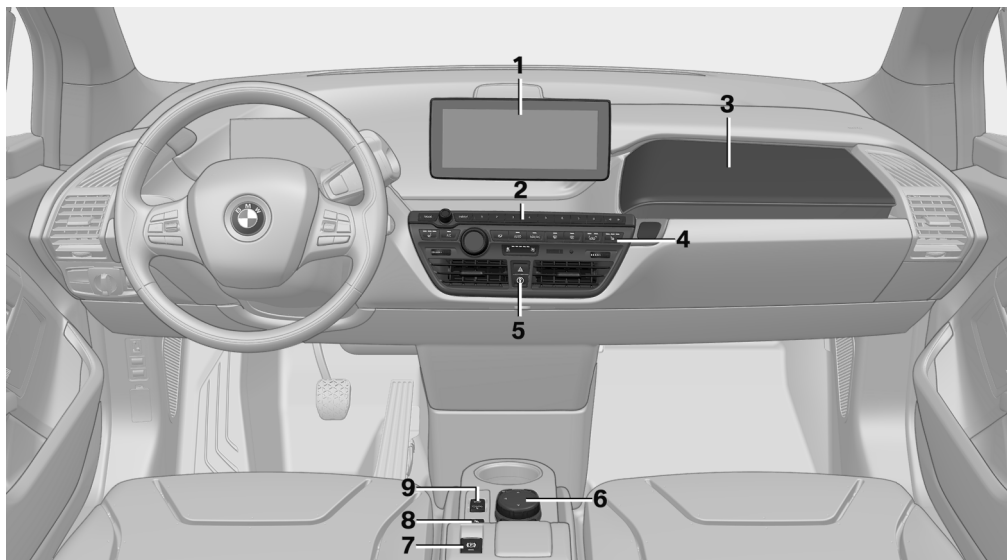

High beams, headlight flasher 69

-  Roadside parking lights 90
-  Computer 85
- 6** Instrument cluster 74
- 7**  Switch drive readiness on and off 62
- 8** Selector lever 64
- 9** Right steering column stalk
-  Wiper 70
-  Rain sensor 71
-  Clean the windshields and headlights 71
- 10** Steering wheel buttons, right
-  Entertainment source
-  Volume
-  Voice activation 26
-  Telephone
- Thumbwheel for selection lists 84
- 11** Adjust steering wheel 57
- 12** Steering wheel buttons, left
-  Store speed 115
-  Resume speed 117
-  Cruise control on/off, interrupting 116
-  Active Cruise Control on/off, interrupting 109
-  Cruise control, adjust distance 109
- Cruise control rocker reel 116
- 13** Horn, total area





All around the center console



- | | |
|---|--|
| <p>1 Control Display 18</p> <p>2 Radio/Multimedia, refer to Integrated Owner's Handbook</p> <p>3 Glove compartment 138</p> <p>4 Climate control 127</p> <p>5  Hazard warning system 193</p> <p> Intelligent Safety 99</p> | <p>6 Controller with buttons 18</p> <p>7 Parking brake 68</p> <p>8  PDC Park Distance Control 117
Rearview camera 120
Parking assistant 122</p> <p>9  Driving Dynamics Control 107</p> |
|---|--|

All around the roofliner



- | | | | | | |
|---|---|--|---|---|--------------------|
| 1 |  | Intelligent Emergency Request 193 | 4 |  | Reading lights 91 |
| 2 |  | Glass sunroof, powered 49 | 5 |  | Interior lights 91 |
| 3 |  | Indicator lamp, front-seat passenger airbag 94 | | | |

iDrive

Vehicle features and options

This chapter describes all standard, country-specific and optional features offered with the series. It also describes features that are not necessarily available in your car, e. g., due to the selected options or country versions. This also applies to safety-related functions and systems.

The concept

The iDrive combines the functions of many switches. Thus, these functions can be operated from a central location.

 Using the iDrive during a trip
To avoid becoming distracted and posing an unnecessary hazard to your vehicle's occupants and to other traffic, never attempt to use the controls or enter information unless traffic and road conditions allow it. ◀

Control elements at a glance

Control elements

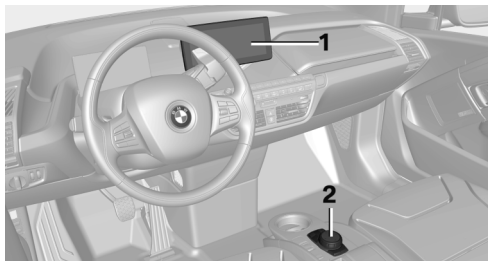

- 1 Control Display
- 2 Controller with buttons and, depending on the equipment version, with touchpad

Control Display

Hints

- ▶ To clean the Control Display, follow the care instructions.
- ▶ Do not place objects close to the Control Display; otherwise, the Control Display or other surfaces can be damaged.
- ▶ In the case of very high temperatures on the Control Display, e.g. due to intense solar radiation, the brightness may be reduced down to complete deactivation. Once the temperature is reduced, e.g. through shadow or climate control system, the normal functions are re-established.

Switching on

1. Turn on operations.
2. Press the controller.

Switch off

1.  Press button.
2. "Turn off control display"

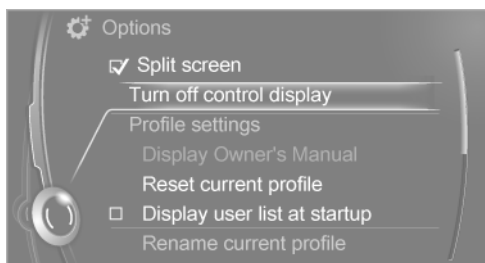

Controller

The buttons can be used to open the menus directly. The controller can be used to select menu items and enter the settings.

Some iDrive functions can be operated using the touchpad on the controller.

1. Turn.

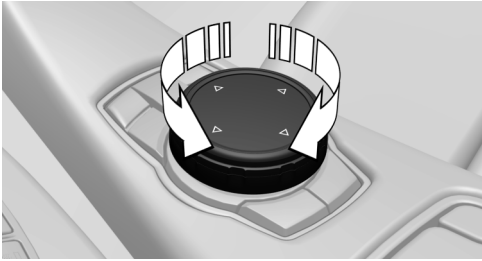

2. Press.



3. Move in four directions.

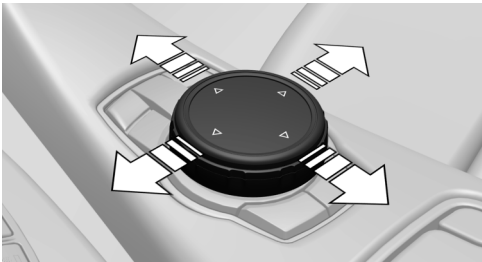

Buttons on controller

Press button	Function
MENU	Open the main menu.
RADIO	Opens the Radio menu.
MEDIA	Opens the Multimedia menu.
NAV	Opens the Navigation menu.
TEL	Opens the phone menu.

Press button	Function
BACK	Displays the previous panel.
OPTION	Opens the Options menu.

Operating concept

Opening the main menu

 Press button.

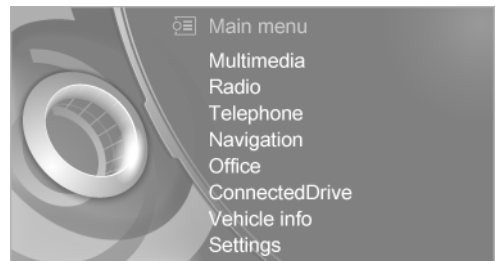

The main menu is displayed.

All iDrive functions can be called up via the main menu.

Selecting menu items

Highlighted menu items can be selected.

1. Turn the controller until the desired menu item is highlighted.



2. Press the controller.

Menu items in the Owner's Manual

In the Owner's Manual, menu items that can be selected are set in quotation marks, e.g., "Settings".

Changing between panels

After a menu item is selected, e.g., "Radio", a new panel is displayed. Panels can overlap.

- ▷ Move the controller to the left.
 - Closes current display and shows previous display.
 - Reopens previous display by pressing BACK button. In this case, the current panel is not closed.
- ▷ Move the controller to the right.
 - Opens new display on top of previous screen.

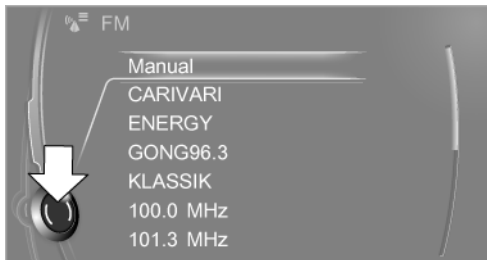

White marks to the left or right indicate that additional panels can be opened.

Display of an opened menu

When selecting a menu, it generally opens with the panel that was last selected in that menu. To display the first panel of a menu:

- ▷ Move the controller to the left repeatedly until the first panel is displayed.
- ▷ Press the menu button on the controller twice.

Opening the Options menu



Press button.

The "Options" menu is displayed.

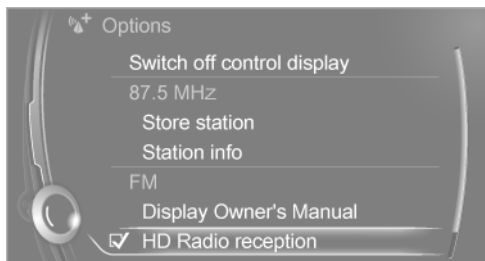

Additional options: move the controller to the right repeatedly until the "Options" menu is displayed.

Options menu

The "Options" menu consists of various areas:

- ▷ Screen settings, e.g., "Split screen".
 - This area remains unchanged.
- ▷ Control options for the selected main menu, e.g., for "Radio".
- ▷ If applicable, further operating options for the selected menu, e.g., "Store station".

Changing settings

1. Select a field.
2. Turn the controller until the desired setting is displayed.

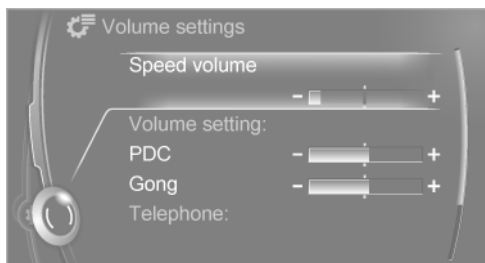

3. Press the controller.

Activating/deactivating the functions

Several menu items are preceded by a checkbox. It indicates whether the function is activated or deactivated. Selecting the menu item activates or deactivates the function.

Function is activated.

- Function is deactivated.

Touchpad

Some iDrive functions can be operated using the touchpad on the controller:

Selecting functions

1. "Settings"
2. "Touchpad"
3. Select the desired function.
 - ▷ "Speller": enter letters and numbers.
 - ▷ "Interactive map": viewing the interactive map.
 - ▷ "Browser": enter Internet addresses.
 - ▷ "Audio feedback": pronounces entered letters and numbers.

Entering letters and numbers

Entering letters requires some practice at the beginning. When entering, pay attention to the following:

- ▷ For the input of upper/lower case letters and numbers, it may be necessary to reel via the controller to the corresponding Input mode, refer to page 24, e.g. when the spelling of upper and lower case letters is identical.
- ▷ Enter characters as they are displayed on the Control Display.
- ▷ Always enter associated characters, such as accents or periods so that the letter can be clearly recognized. Possible input depends on the set language. Where necessary, enter special characters via the controller.
- ▷ To delete a character, slide to the left on the touchpad.
- ▷ To enter a blank space, slide to the right in the center of the touchpad.
- ▷ To enter a hyphen, slide to the right in the upper area of the touchpad.

- ▷ To enter an underscore, swipe to the right in the lower area of the touchpad.

Using interactive map and Internet

Via touch-pad move the interactive map in the navigation system and Internet sites.

Function	Controls
Move interactive map or Internet sites.	Swipe into respective direction.
Enlarge/shrink interactive map or Internet sites.	Drag in or out on the touchpad with fingers.
Display the menu or open a link in the Internet.	Tap once.

Changing settings

You may change control display settings via touchpad. Swipe left or right accordingly.

Example: setting the clock

Setting the clock

On the Control Display:

1.  Press button. The main menu is displayed.
2. Turn the controller until "Settings" is highlighted, and then press the controller.



3. If necessary, move the controller to the left to display "Time/Date".

- Turn the controller until "Time/Date" is highlighted, and then press the controller.

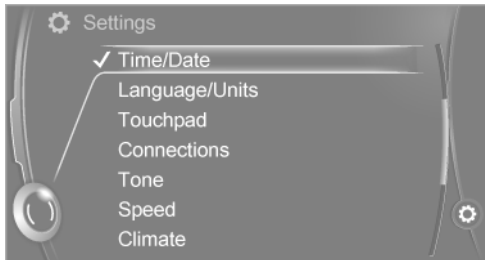

- Turn the controller until "Time:" is highlighted, and then press the controller.

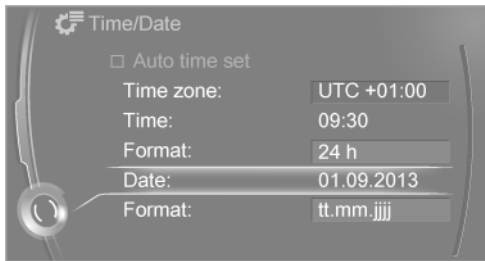

- Turn the controller to set the hours and press the controller.
- Turn the controller to set the minutes and press the controller.

Status information

Status field

The following information is displayed in the status field at the top right:

- ▷ Time.
- ▷ Current entertainment source.
- ▷ Sound output, on/off.
- ▷ Locating the vehicle.
- ▷ Wireless network reception strength.
- ▷ Phone status.
- ▷ Traffic bulletin reception.











Status field symbols

The symbols are grouped as follows.



Radio symbols

Symbol	Meaning
	HD radio station is being received.



Telephone symbols

Symbol	Meaning
	Incoming or outgoing call.
	Missed call.
	Wireless network reception strength. Symbol flashes: network search.
	Wireless network is not available.
	Bluetooth is switched on.
	Roaming is active.
	Text message was received.
	Check the SIM card.
	SIM card is blocked.
	SIM card is missing.
	Enter PIN.

Entertainment symbols

Symbol	Meaning
	Music collection.
	Gracenote® database.
	AUX-IN port.

Additional symbols

Symbol	Meaning
	Spoken instructions are turned off.
	Check the current vehicle position.

Split screen

General information

Additional information can be displayed on the right side of the split screen, e.g., information from the computer.

In the divided screen view, the so-called split screen, this information remains visible even when you change to another menu.

Switching the split screen on and off

-  Press button.
- "Split screen"

Selecting the display

-  Press button.
- "Split screen"
- Move the controller until the split screen is selected.
- Press the controller or select "Split screen content".
- Select the desired menu item.

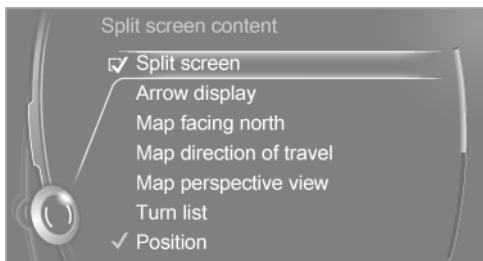



Programmable memory buttons

General information



The iDrive functions can be stored on the programmable memory buttons and called up directly, e.g., radio stations, navigation destinations, phone numbers and menu entries.

Settings are stored for the profile currently in use.

Saving a function

- Highlight the function via the iDrive.
- ... Press and hold the desired button, until a signal sounds.

Running a function

- ... Press button.
The function will work immediately.
This means, e.g., that the number is dialed when a phone number is selected.

Displaying the button assignment

Touch buttons with bare fingers. Do not wear gloves or use objects.

The key assignment is displayed at top edge of screen.



Deleting the button assignments

- Press buttons 1 and 8 simultaneously for approx. five seconds.
- "OK"

Deleting personal data in the vehicle

The concept

Depending on the usage, the vehicle saves personal data, such as stored radio stations. These personal data can be permanently deleted through iDrive.

General information

Depending on the equipment package, the following data can be deleted:

- ▷ Personal Profile settings.
- ▷ Stored radio stations.
- ▷ Stored Favorites buttons.
- ▷ Travel and computer information.
- ▷ Music collection.
- ▷ Navigation, e.g. stored destinations.
- ▷ Phone book.
- ▷ Online data, e.g. Favorites, cookies.
- ▷ Voice notes.
- ▷ Login accounts.
- ▷ RemoteApp smartphone tethering.

Altogether, the deletion of the data can take up to 30 minutes.

Functional requirement

Data can only be deleted while stationary.

Deleting data

Heed and follow the instructions on the Control Display.



1. Turn on operations.
2. "Settings"
3. Open "Options".
4. "Delete personal data"
5. "Continue"
6. "OK"

Entering letters and numbers

General information

On the Control Display:

1. Turn the controller: select letters or numbers.
2. Select additional letters or numbers if needed.
3. "OK": confirm the entry.

Symbol	Function
	Press the controller: delete the letter or number.
	Press the controller for an extended period: delete all letters or numbers.

Switching between cases, letters and numbers

Depending on the menu, you can reel between entering upper and lower case, letters and numbers:

Symbol	Function
A^BC	Enter the letters.
1@+	Enter the numbers.
abc or ABC	Tip controller up.

Without navigation system

@^A A^a a[@] Select the symbol.

Entry comparison

Entering names and addresses: choice is narrowed down with every letter entered and letters may be added automatically.

Entries are continuously compared with data stored in the vehicle.

- ▷ Only those letters are offered during input for which data is available.

- ▶ Target search: names of locations may be entered in languages available through Control Display.

Voice activation system

Vehicle features and options

This chapter describes all standard, country-specific and optional features offered with the series. It also describes features that are not necessarily available in your car, e. g., due to the selected options or country versions. This also applies to safety-related functions and systems.

The concept

- ▷ Most functions displayed on the Control Display can be operated by voice commands via the voice activation system. The system supports you with announcements during input.
- ▷ Functions that can only be used when the vehicle is stationary cannot be used via the voice activation system.
- ▷ The system uses a special microphone on the driver's side.
- ▷ ...« Verbal instructions in the Owner's Manual to use with the voice activation system.

Requirements

Via the Control Display, set a language that is also supported by the voice activation system so that the spoken commands can be identified.

Set the language, refer to page 87.

Using voice activation

Activating the voice activation system

1.  Press button on the steering wheel.
2. Wait for the signal.
3. Say the command.

A command that is recognized by the voice activation system is announced and displayed in the instrument cluster.

 This symbol in the instrument cluster indicates that the voice activation system is active. If no other commands are available, use function via iDrive.

Terminating the voice activation system

 Briefly press the button on the steering wheel or »Cancel«.

Possible commands

Most menu items on the Control Display can be voiced as commands.

The available commands depend on the menu that is currently displayed on the Control Display.

There are short commands for many functions. You may select lists such as phone lists via voice activation. Read these lists out loud exactly as they show in the respective list.

Having possible commands read aloud

You can have available commands read out loud for you: »Voice commands«

E. g. if the "Settings" menu is displayed, the commands for the settings are read out loud.

Executing functions using short commands

Execute functions on the main menu via short commands. It almost doesn't matter which menu item is selected, e.g., ›Vehicle status‹.

Help dialog for the voice activation system

Calling up help dialog: ›Help‹

Additional commands for the help dialog:

- ▷ ›Help with examples‹: announces information about the current operating options and the most important commands for them.
- ▷ ›Help with voice activation‹: information about the principle of operation for the voice activation system is announced.

One example: open the tone settings

Via the main menu

The commands of the menu items are spoken just as they are selected via the controller.

1. Turn on the Entertainment sound output if needed.
2.  Press button on the steering wheel.
3. ›Radio‹
4. ›Tone‹

Via short command

The desired tone settings can also be started via a short command.

1. Turn on the Entertainment sound output if needed.
2.  Press button on the steering wheel.
3. ›Tone‹

Setting the voice dialog

Set system to standard dialog or use a short version.

The short version of the voice dialog plays back short messages in abbreviated form.

1. "Settings"
2. "Language/Units"
3. "Speech type:"
4. Select setting.

Adjusting the volume

Turn the volume button while giving an instruction until the desired volume is set.

- ▷ The volume remains constant even if the volume of other audio sources is changed.
- ▷ The volume is stored for the profile currently in use.

Hints on Emergency Requests

Do not use the voice activation system to initiate an Emergency Request. In stressful situations, the voice and vocal pitch can change. This can unnecessarily delay the establishment of a phone connection.

Instead, use the SOS button, refer to page 193, close to the interior mirror.

Environmental conditions

- ▷ Say the commands, numbers, and letters smoothly and with normal volume, emphasis, and speed.
- ▷ Always say commands in the language of the voice activation system.
- ▷ Keep the doors, windows, and glass sunroof closed to prevent noise interference.

- ▶ Avoid making other noise in the vehicle while speaking.

Integrated Owner's Manual in the vehicle

Vehicle features and options

This chapter describes all standard, country-specific and optional features offered with the series. It also describes features that are not necessarily available in your car, e. g., due to the selected options or country versions. This also applies to safety-related functions and systems.

Integrated Owner's Manual in the vehicle

The Integrated Owner's Manual can be displayed on the Control Display. It specifically describes features and functions found in the vehicle.

Components of the Integrated Owner's Manual

The Integrated Owner's Manual consists of three parts, which offer various levels of information or possible access.

Quick Reference Guide

The Quick Reference Guide provides information how to operate the car, how to use basic vehicle functions or what to do in case of a breakdown. This information can also be displayed while driving.

Search by images

Image search provides information and descriptions. This is helpful when the terminology for a feature is not at hand.

Owner's Manual

Search for information and descriptions by entering terms selected from the index.

Select components

1.  Press button.
2. Turn the controller: open "Vehicle info".
3. Press the controller.
4. Selecting desired range:
 - ▷ "Quick reference"
 - ▷ "Search by pictures"
 - ▷ "Owner's Manual"

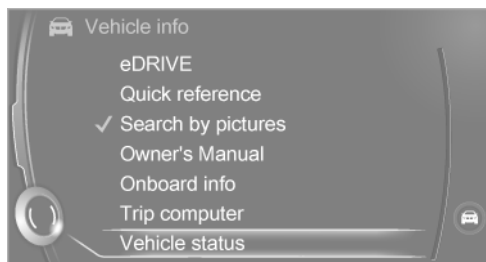

Leafing through the Owner's Manual

Page by page with link access

Turn the controller until the next or previous page is displayed.

Page by page without link access

Scroll through the pages directly while skipping the links.

Highlight the symbol once. Now simply press the controller to browse from page to page.



Scroll back.



Scroll forward.

Context help - Owner's Manual to the temporarily selected function

You may open the relevant information directly.

Opening via the iDrive

To move directly from the application on the Control Display to the Options menu:

1.  Press button or move the controller to the right repeatedly until the "Options" menu is displayed.
2. "Display Owner's Manual"



Opening when a Check Control message is displayed

Directly from the Check Control message on the Control Display:

"Display Owner's Manual"

Changing between a function and the Owner's Manual

To reel from a function, e. g., radio, to the Owner's Manual on the Control Display and to alternate between the two displays:

1.  Press button or move the controller to the right repeatedly until the "Options" menu is displayed.
2. "Display Owner's Manual"
3. Select the desired page in the Owner's Manual.
4.  Press button again to return to last displayed function.
5.  Press button to return to the page of the Owner's Manual displayed last.



To alternate permanently between the last displayed function and the Owner's Manual repeat steps 4 & 5. Opens a new display every time.

Programmable memory buttons



General information

The Owner's Manual can be stored on the programmable memory buttons and called up directly.

Storing

1. "Owner's Manual" Select via the iDrive.
2. ... Press selected button for more than 2 seconds.

Executing

- ... Press button.
The Owner's Manual is displayed immediately.

BMW eDRIVE

Vehicle features and options

This chapter describes all standard, country-specific and optional features offered with the series. It also describes features that are not necessarily available in your car, e. g., due to the selected options or country versions. This also applies to safety-related functions and systems.

BMW eDRIVE

At a glance

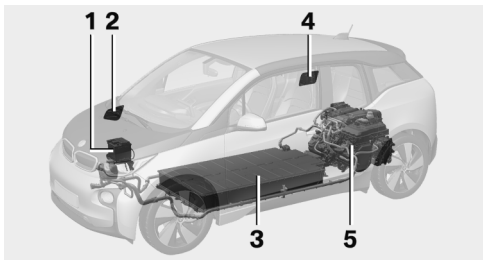

- 1 Vehicle battery
- 2 Fuel filler flap
- 3 High-voltage battery
- 4 Charging port
- 5 Drive unit

The concept

The vehicle can be operated completely emissions free using its electrical drive system.

The special high-voltage battery supplies the electric motor as well as the comfort features with power.

The high-voltage battery is charged via a charging cable, e.g., when parked or while driving by energy recovery.

Charging can be done especially quickly via special power connections. However, charging

via conventional power supply - at home - is also possible.

On the go, the energy recovery ensures that only little energy is lost when braking.

When the vehicle decelerates, the electric motor assumes the function of a generator and completely or partially converts the freed up motion energy into electrical power.

As a result the high-voltage battery is partially recharged in order to reach maximum range.

An optional Range Extender can supply the drive system with power and thus increase the range of the vehicle.

Functions

Electric driving: eDRIVE

The vehicle is powered exclusively by the electric motor. The accelerator pedal can be used not just for acceleration, but also for deceleration. In this case, the electric motor works like a generator and charges the high voltage battery. With a sensible driving style, this function can be used for especially efficient energy recovery and comfortable driving, using just the accelerator pedal.

Coasting

An especially efficient operating point is so-called coasting. In this case, the vehicle is decelerated only by driving resistance and no energy flows between high-voltage battery and electric motor. In order to coast, depress the accelerator pedal far enough that the mark in the instrument cluster, refer to page 74, is exactly in the center.

Energy recovery: CHARGE

The high-voltage battery is charged while driving through energy recovery.

The electric motor acts as a generator and converts the kinetic energy of the vehicle into electric current.

Charging can take place in various situations while the vehicle is in motion:

- ▷ As soon as the gas pedal is only slightly depressed.
- ▷ During vehicle braking.

The mark in the instrument cluster is located within the CHARGE range.

Sensible driving and early speed reduction are important to make full use of the energy recovery feature.

Display

The eDRIVE displays, refer to page 74, provide information about the current state of the drive and visualize the system's use in a diagram.

Maximize energy-saving driving and range

Energy-saving driving is the basic prerequisite for as large a range as possible. eDRIVE provides various functions that assist with an energy-saving driving style and in the process help to monitor the range and if needed to increase it. The following instructions provide an overview of the available functions and the personal measures.

Before driving

eDRIVE allows using the air conditioner even before driving off. The stationary climate control, refer to page 132, provides more range than full air conditioning while driving.

Parked car ventilation during the charging process can provide maximum range when driving off.

Trip planning and special functions of the navigation system

Enter your destination and the following functions will be available:

- ▷ ECO PRO routing for efficient route planning.
- ▷ ECO PRO+ mode for economical driving with limited comfort features.
- ▷ Charging assistant helps to find and include public charging stations.
- ▷ Range assistant automatically checks the radius of action, see Integrated Owner's Manual.
- ▷ Intermodal routing for trip planning using public transportation, refer to Integrated Owner's Manual.
- ▷ Monitoring of a charging station, whose reachability is automatically checked, see Integrated Owner's Manual.

During driving

- ▷ General driving tips, refer to page 150, for increasing the range.
- ▷ Use the eDRIVE system efficiently, refer to page 144, for an optimized driving style.
- ▷ ECO PRO driving style analysis, refer to page 153, for driving style analysis.
- ▷ ECO PRO and ECO PRO+ mode, refer to page 151, for increasing the range.
- ▷ Display of the Fuel consumption history, refer to page 76.
- ▷ Display of secondary functions and the potential range, refer to page 77.

After the trip

- ▷ Charge vehicle, refer to page 156, and plan next trip.
- ▷ Prepare for long downtimes, refer to page 201.

BMW i Remote app

A special BMW i Remote App allows to control and display certain vehicle functions using a smartphone.

Safety information

Read the information on safe handling of the high-voltage system, refer to page 196.

Long-term

Follow the instructions for vehicle storage and for longer idle periods, refer to page 201.





Controls

This chapter is intended to provide you with information that will give you complete control of your vehicle. All features and accessories that are useful for driving and your safety, comfort and convenience are described here.

Opening and closing

Vehicle features and options

This chapter describes all standard, country-specific and optional features offered with the series. It also describes features that are not necessarily available in your car, e. g., due to the selected options or country versions. This also applies to safety-related functions and systems.

Remote control/key

General information

The vehicle is supplied with two remote controls with integrated key.

Every remote control holds a replaceable battery.

You may set the key functions depending on the optional features and country-specific version. For Settings, refer to page 45.

The vehicle stores personal settings for every remote control. Personal Profile, refer to page 37.

The remote controls hold information on required maintenance. Service data in the remote control, refer to page 185.

At a glance



- 1 Unlocking
- 2 Locking

- 3 Unlocking hood
- 4
 - ▶ With alarm system: panic mode
 - ▶ Without panic mode: 

Adjustable function: headlight courtesy delay feature, stationary air conditioning or unlock tailgate.

Integrated key

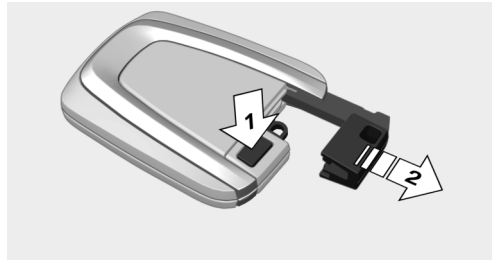

Press button on the remote control, arrow 1, and pull out the key, arrow 2.

The integrated key fits the driver's door lock.

Replacing the battery

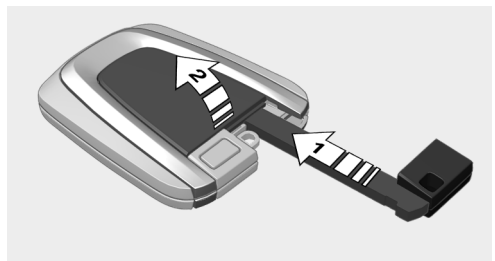

1. Remove integrated key from remote control.
2. Raise the cover of the battery compartment, arrow 1.
3. Remove the cover of the battery compartment, arrow 2.

4. Insert a battery of the same type with the positive side facing up.
5. Press the cover closed.



Take the used battery to a recycling center or to your service center.

New remote controls

New remote controls are available from the service center.

Loss of the remote controls

Lost remote controls can be disabled by your service center.

Emergency detection of remote control

Also in the following situations, radio-ready state and drive readiness can be established:

- ▷ Interference of radio transmission to remote control by external sources e.g., by radio masts.
- ▷ Empty battery in remote control.
- ▷ Interference from radio transmissions through mobile devices in close proximity to remote control.
- ▷ Interference of radio transmission by charger while charging items such as mobile devices in the vehicle.

A Check Control message is displayed if one attempts to turn on the radio-ready state or activate engine readiness.

Activation of drive readiness via emergency detection of the remote control

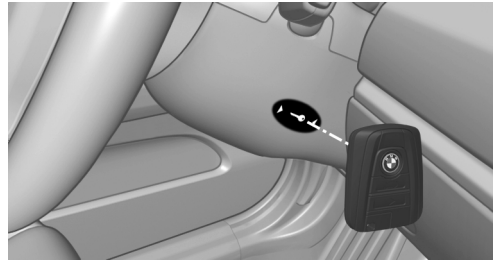

If a respective Check Control message appears, hold the remote control with its back against the marked area on the steering column. The BMW logo on the remote control should be at the same height as the marked area. Press the Start/Stop button within 10 seconds while pressing the brake pedal.

If the remote control is not recognized: slightly change the height position of the remote control and repeat the procedure.

Personal Profile

The concept

Individual settings in the vehicle are saved in personal profiles. Every remote control is assigned the last active profile.

Three personal profiles and a guest profile can be created.

- ▷ Changes to the settings are automatically saved in the profile currently activated.
- ▷ Unlocking the car activates the profile that is stored in the remote control.
- ▷ Your personal settings will be recognized and activated even if the vehicle had been operated with another remote control.

Adjusting

The settings for the following systems and functions are saved in the active profile. The

scope of storable settings is country- and equipment-dependable.

- ▷ Unlocking and locking.
- ▷ Lights.
- ▷ Climate control.
- ▷ Radio.
- ▷ Instrument cluster.
- ▷ Programmable memory buttons.
- ▷ Volumes, tone.
- ▷ Control Display.
- ▷ Navigation.
- ▷ Park Distance Control PDC.
- ▷ Rearview camera
- ▷ Driving Dynamics Control.
- ▷ Cruise control.
- ▷ Intelligent Safety.

Profile management

Opening profiles

Regardless of the remote control in use a different profile may be activated.

1. "Settings"
2. "Profiles"
3. Select a profile.

The activated profile is assigned to the currently used remote control.

Renaming profiles

1. "Settings"
2. "Profiles"
3. "Options"
4. "Rename current profile"

Resetting profiles

The settings of the active profile are reset to their default values.

1. "Settings"
2. "Profiles"
3. "Options"
4. "Reset current profile"

Exporting profiles

Most settings of the active profile and the saved contacts can be exported.

This can be helpful for securing and retrieving personal settings, before delivering the vehicle to a workshop, e.g. Profiles can be taken to another vehicle equipped with the Personal Profile function.

The following export options are available:

- ▷ Via BMW Online.
- ▷ Via the USB port to a USB device.

Popular file systems for USB devices are supported. FAT32 and exFAT are the recommended formats for profile export. Other formats may not support the export.

1. "Settings"
2. "Profiles"
3. "Export profile"
4. BMW Online: "BMW Online"
USB port: "USB device"

Importing profiles

Profiles exported via BMW Online can also be imported via BMW Online.

Profiles stored on a USB device can be imported via the USB interface.

Existing settings and contacts are overwritten with the imported profile.

1. "Settings"
2. "Profiles"
3. "Import profile"
4. BMW Online: "BMW Online"

USB interface: "USB device"

Using the guest profile

The guest profile is for individual settings that are saved in none of the three personal profiles.

This can be useful for drivers who are using the vehicle temporarily and do not have their own profile.

1. "Settings"
2. "Profiles"
3. "Guest"

The guest profile cannot be renamed. It is not assigned to the current remote control.

Display profile list during start

The profile list can be displayed during each start to select the desired profile.

1. "Settings"
2. "Profiles"
3. "Options"
4. "Display user list at startup"

Using the remote control

Note



Take the remote control with you

People or animals left unattended in a parked vehicle can lock the doors from the inside. Always take the remote control with you when leaving the vehicle so that the vehicle can then be opened from the outside. ◀

Unlocking



Press button on the remote control.

- ▷ All doors and the tailgate are unlocked.
- ▷ Interior lamps and courtesy lamps are activated. This function is not available, if the interior lamps were switched off manually.

- ▷ The welcome lamps are switched on, if this function was activated.
- ▷ Exterior mirrors folded through convenient closing are folded open.

You can set how the vehicle is to be unlocked. For Settings, refer to page 45.

The alarm system, refer to page 46, is disarmed.

Convenient opening



Press and hold this button on the remote control after unlocking.

The windows and the glass sunroof are opened, as long as the button on the remote control is pressed.

Locking



Locking from the outside

Do not lock the vehicle from the outside with people inside the car, as the vehicle cannot be unlocked from inside without special knowledge. ◀



Press button on the remote control.

All doors and the tailgate are locked.

The alarm system, refer to page 46, is armed.

Switching on interior lights and courtesy lights



Press button on the remote control with the vehicle locked.

This function is not available, if the interior lamps were switched off manually.

If the button is pressed again within 10 seconds after vehicle was locked, the interior motion sensor and tilt alarm sensor of the anti-theft warning system, refer to page 47, are turned off. After locking, wait 10 seconds before pressing the button again.

Unlocking hood



Press button on the remote control for approx. 1 second.

Depending on the features and the country version, it is also possible to have door unlocked. Create the settings, refer to page 45.

If the doors were not unlocked, the hood is locked again as soon as it is pushed closed.



Do not place the remote control under the hood

Take the remote control with you and do not leave it under the hood; otherwise, the remote control is locked inside the vehicle when the hood is closed. ◀

Without alarm system: unlocking the tailgate

The Tailgate function must be set for the remote control button. For Settings, refer to page 45.



Press button on the remote control for approx. 1 second.

The tailgate opens slightly, regardless of whether the vehicle was previously locked or unlocked.

Depending on the features and the country version, it is also possible to have door unlocked. Create the settings, refer to page 45.

If the doors were not unlocked, the tailgate is locked again as soon as it closes.



Do not place the remote control in the cargo area

Take the remote control with you and do not leave it in the cargo area; otherwise, the remote control is locked inside the vehicle when the tailgate is closed. ◀



Provide edge protection

Sharp objects or those with edges can hit the rear window while driving and damage the heat conductors of the rear window. Provide edge protection. ◀

Without alarm system: switching the headlamp courtesy delay feature on

The headlight courtesy delay feature function must be set for the remote control button. For Settings, refer to page 45.



Briefly press the button on the remote control.

The duration can be set in the Control Display.

With alarm system: panic mode

You can trigger the alarm system if you find yourself in a dangerous situation.



Press button on the remote control for at least 3 seconds.

To reel off the alarm: press any button.

Malfuction

Remote control detection by the vehicle can among others be malfunctioning under the following circumstances:

- ▷ Interference of the radio connection from transmission towers or other equipment with high transmit power.
- ▷ Shielding of the remote control due to metal objects.
- ▷ Interference of the radio connection from mobile phones or other electronic devices in direct proximity.

Do not transport the remote control together with metal objects or electronic devices.

In the case of interference, the vehicle can also be unlocked and locked from the outside without remote control, refer to page 41.

For US owners only

The transmitter and receiver units comply with part 15 of the FCC/Federal Communication Commission regulations. Operation is governed by the following:

FCC ID:

- ▷ LX8766S.
- ▷ LX8766E.
- ▷ LX8CAS.
- ▷ LX8CAS2.
- ▷ MYTCAS4.

Compliance statement:

This device complies with part 15 of the FCC Rules. Operation is subject to the following two conditions:

- ▷ This device may not cause harmful interference, and
- ▷ this device must accept any interference received, including interference that may cause undesired operation.

Any unauthorized modifications or changes to these devices could void the user's authority to operate this equipment.

Without remote control

From the outside



Locking from the outside

Do not lock the vehicle from the outside with people inside the car, as the vehicle cannot be unlocked from inside without special knowledge. ◀



Remove the key before pulling the door handle

Before pulling the outside door handle, remove the key to avoid damaging the paintwork and the key. ◀

Unlock or lock the driver's door via the door lock using the integrated key, refer to page 36.

The other doors must be unlocked or locked from the inside.

1. Remove lid on the door lock.

To do this, slide the integrated key into the opening from below and unlock the lid.

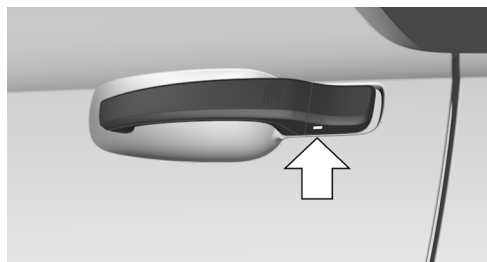

2. Unlock or lock door lock.

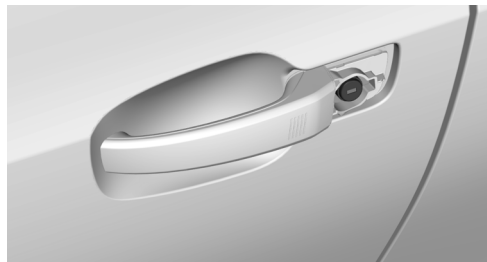

Alarm system

The alarm system is not armed if the vehicle is locked with the integrated key.

The alarm system is triggered when the door is opened, if the vehicle was unlocked via the door lock.



In order to terminate this alarm, unlock vehicle with the remote control or establish radio-ready state, if needed, through emergency detection of the remote control, refer to page 37.

From the inside

Unlocking and locking



Via the buttons for the central locking system.

- ▶  By pressing the button, the vehicle is locked with the doors closed.
- ▶  Pressing the button unlocks the vehicle.

The vehicle is not secured against theft when locking.

The vehicle locks automatically after you drive off.

In the event of a severe accident, the vehicle is automatically unlocked. The hazard warning system and interior lights come on.

Unlocking and opening

- ▶  Press the central locking system button to unlock the doors together, and then pull the door handle above the armrest.
- ▶ Pull the door opener on the door to be opened. The other door remain locked.

Rear doors

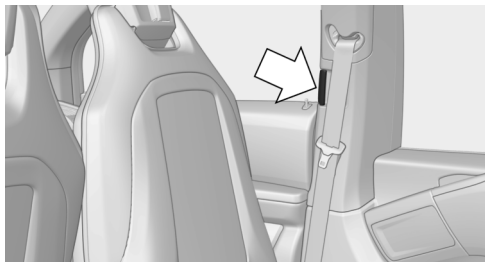

The rear doors can only be opened using the handle on the inside, arrow. The corresponding front door must be opened.

To better reach the front door's handle fold the front seat's backrests, refer to page 52, down.

Before exiting the vehicle, make sure that the front safety belt is completely wound up.

When closing, make sure that the corresponding front door is far enough open.

Hood

Opening from the outside



Press button on the remote control for approx. 1 second.

The hood is unlocked and slightly raised.

As the case may be, the doors are also unlocked. Unlocking with the remote control, refer to page 40.

Opening from the inside



With the vehicle is stationary, press the button in the driver's footwell.

The hood is unlocked and slightly raised.

Manual opening

For example, in case of an electrical malfunction.

1. Remove cover underneath the unlock buttons.

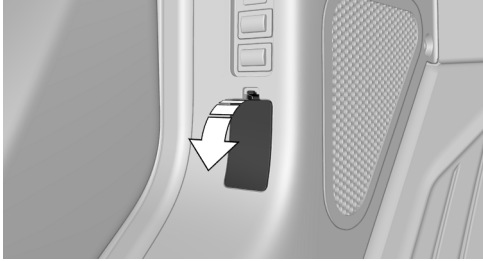

2. Remove wire cable and pull it back.
The hood is unlocked.

Tailgate

Opening

The tailgate swings back and up when it opens.

Ensure that adequate clearance is available before opening.

Opening from the outside



- ▷ Press button next to the tailgate.
- ▷  Without alarm system: press button on the remote control for approx. 1 second.

The Tailgate function must be set for the remote control button. For Settings, refer to page 45.

As the case may be, the doors are also unlocked. Unlocking with the remote control, refer to page 40.

The tailgate is unlocked and can be swung upward.

Opening from the inside



With the vehicle is stationary, press the button in the driver's footwell.

Closing

Hints

 Keep the closing path clear
Make sure that the closing path of the tailgate is clear; otherwise, injuries may result. ◀

 Do not place the remote control in the cargo area

Take the remote control with you and do not leave it in the cargo area; otherwise, the remote control is locked inside the vehicle when the tailgate is closed. ◀

 Provide edge protection
Sharp objects or those with edges can hit the rear window while driving and damage the heat conductors of the rear window. Provide edge protection. ◀

Closing



Recessed grips on the inside trim of the tailgate can be used to conveniently pull down the tailgate.

Comfort Access

The concept

The vehicle can be accessed without activating the remote control.

All you need to do is to have the remote control with you, such as in your pants pocket.

The vehicle automatically detects the remote control when it is in close proximity or in the car's interior.

Comfort Access supports the following functions:

- ▷ Unlocking/locking of the vehicle.
- ▷ Convenient closing.
- ▷ Separate unlocking of the tailgate.
- ▷ Establish drive readiness.

Functional requirements

- ▷ There are no external sources of interference nearby.
- ▷ To lock the vehicle, the remote control must be located outside of the vehicle.
- ▷ The next unlocking and locking cycle is not possible until after approx. 2 seconds.
- ▷ Drive readiness can only be established if the remote control is in the vehicle.

Unlocking



Grasp the door handle on the driver's or front passenger door completely, arrow.

This corresponds with pressing the button on the remote control. 

Locking

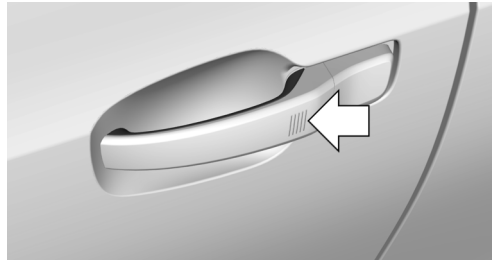

Touch the surface on the door handle of the driver's or front passenger door, arrow, with your finger for approx. 1 second without grasping the door handle.

This corresponds with pressing the button on the remote control. 

To save battery power, ensure that all power consumers are turned off before locking the vehicle.

Convenient closing



Monitor closing

Monitor closing to ensure that no one becomes trapped. ◀

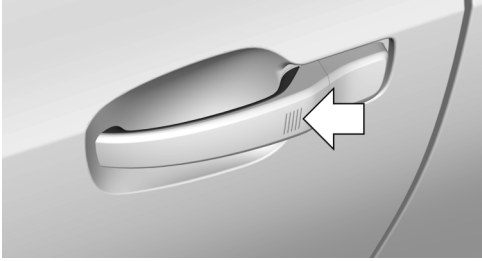

Touch the surface on the door handle of the driver's or front passenger door, arrow, with your finger and hold it there without grasping the door handle.

This corresponds to pressing and holding  the remote control button.

In addition to locking, the windows and the glass sunroof close and the exterior mirrors fold in.

Unlocking the tailgate separately

Press button on tailgate's exterior

Without alarm system: This corresponds with pressing the button on the remote control , if the tailgate function is set.

The situation of the doors does not change.

 Note the opening height of the tailgate

The tailgate swings back and up when it opens. Ensure that there is sufficient clearance when the tailgate opens; otherwise, damage may result. ◀

 Do not place the remote control in the cargo area

Take the remote control with you and do not leave it in the cargo area; otherwise, the remote control is locked inside the vehicle when the tailgate is closed. ◀

Malfunction

Remote control detection by the vehicle can among others be malfunctioning under the following circumstances:

- ▷ Interference of the radio connection from transmission towers or other equipment with high transmit power.
- ▷ Shielding of the remote control due to metal objects.
- ▷ Interference of the radio connection from mobile phones or other electronic devices in direct proximity.

Do not transport the remote control together with metal objects or electronic devices.

In the case of a malfunction, unlock and lock the vehicle using the buttons of the remote control or using the integrated key, refer to page 41.

Adjusting

Unlocking

The settings are saved in the active profile, refer to page 37.

Doors

1. "Settings"
2. "Doors/key"
3.  Select the symbol.
4. Select the desired function:
 - ▷ "Driver's door only"

Only the driver's door is unlocked. Pressing again unlocks the entire vehicle.
 - ▷ "All doors"

The entire vehicle is unlocked.

Hood

Depending on optional features and country version, this setting is not offered in some cases.

1. "Settings"
2. "Doors/key"

3.  Select the symbol.
4. Select the desired function:
 - ▷ "Front compartment lid"
The hood is unlocked.
 - ▷ "Front lid and door(s)"
The hood and the doors are unlocked.

Without alarm system: tailgate

Depending on optional features and country version, this setting is not offered in some cases.

1. "Settings"
2. "Doors/key"
3.  Select the symbol.
4. Select the desired function:
 - ▷ "Tailgate"
The tailgate is unlocked.
 - ▷ "Tailgate + door(s)"
The tailgate and the doors are unlocked.

Confirmation signals from the vehicle

The settings are saved in the active profile, refer to page 37.

1. "Settings"
2. "Doors/key"
3. Deactivate or activate the desired confirmation signals.
 - ▷ "Acoustic sig. lock/unlock"
 - ▷ "Flash when lock/unlock"

Automatic locking

The settings are saved in the active profile, refer to page 37.

1. "Settings"
2. "Doors/key"
3. Select the desired function:
 - ▷ "Lock if no door is opened"

The vehicle locks automatically after a short period of time if no door is opened.

Without alarm system: headlamp courtesy delay feature/standing climate control

The settings are saved in the active profile, refer to page 37.

1. "Settings"
2. "Doors/key"
3.  Select the symbol.
4. Select the desired function:
 - ▷ "Pathway lighting"
Headlight courtesy delay feature
 - ▷ "Comfort climate control"
Stationary climate control

Alarm system

The concept

When the vehicle is locked, the vehicle alarm system responds to:

- ▷ Opening a door, the hood or the tailgate.
- ▷ Movements in the interior.
- ▷ Changes in the vehicle tilt, e. g., during attempts at stealing a wheel.
- ▷ Disconnected battery voltage.

The alarm system briefly signals tampering:

- ▷ By sounding an acoustic alarm.
- ▷ By switching on the hazard warning system.
- ▷ By flashing the daytime running lights.

Arming and disarming the alarm system

When you unlock or lock the vehicle, either with the remote control or via the Comfort Access, the alarm system is disarmed or armed at the same time.

Door lock and armed alarm system

The alarm system is triggered when the door is opened, when the vehicle is unlocked via the door lock.

Tailgate and armed alarm system

The tailgate can be opened even when the alarm system is armed.

After the tailgate is closed, it is locked and monitored again when the doors are locked. The hazard warning system flashes once.

Panic mode

You can trigger the alarm system if you find yourself in a dangerous situation.



Press button on the remote control for at least 3 seconds.

To reel off the alarm: press any button.

Indicator lamp on the interior rearview mirror

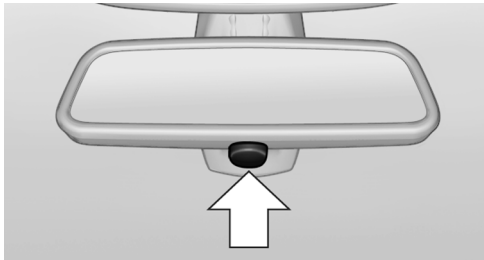

- ▷ The indicator lamp flashes briefly every 2 seconds:
The system is armed.
- ▷ The indicator lamp flashes after locking:
The doors, hood or tailgate is not closed properly, but the rest of the vehicle is secured.
After 10 seconds, the indicator lamp flashes continuously. Interior motion sensor and tilt alarm sensor are not active.

When the still open access is closed, interior motion sensor and tilt alarm sensor will be switched on.

- ▷ The indicator lamp goes out after unlocking:
The vehicle has not been tampered with.
- ▷ The indicator lamp flashes after unlocking until the radio-ready state is switched on, but no longer than approx. 5 minutes:
An alarm has been triggered.

Tilt alarm sensor

The tilt of the vehicle is monitored.

The alarm system responds in situations such as attempts to steal a wheel.

Interior motion sensor

The windows and glass sunroof must be closed for the system to function properly.

Avoiding unintentional alarms

The tilt alarm sensor and interior motion sensor can be switched off together, such as in the following situations:

- ▷ In automatic car washes.
- ▷ In duplex garages.
- ▷ During transport on trains carrying vehicles, at sea or on a trailer.
- ▷ With animals in the vehicle.

Switching off the tilt alarm sensor and interior motion sensor



Press the remote control button again within 10 seconds as soon as the vehicle is locked.

The indicator lamp lights up for approx. 2 seconds and then continues to flash.

The tilt alarm sensor and interior motion sensor are turned off, until the vehicle is locked again.

Switching off the alarm

- ▷ Unlock vehicle with the remote control or establish radio-ready state, if needed through emergency detection of remote control, refer to page 37.
- ▷ With Comfort Access: If you are carrying the remote control on your person, grasp the driver side or front passenger side door handle completely.



Power windows

General information

-  Take the remote control with you
Take the remote control with you when leaving the vehicle so that children, e.g., cannot operate the power windows and injure themselves. ◀





Opening

- ▷  Press the button to the resistance point.
The window opens while the reel is held.
- ▷  Press the reel beyond the resistance point.
The window opens automatically. Pressing the reel again stops the motion.

See also: Convenient opening, refer to page 39, via remote control.

Closing

-  Keep the closing path clear
Monitor closing and make sure that the closing path of the window is clear; otherwise, injuries may result. ◀
- ▷  Pull the reel to the resistance point.
The window closes while the reel is held.
- ▷  Pull the reel beyond the resistance point.
The window closes automatically. Pulling again stops the motion.

See also: closing by means of Comfort Access, refer to page 44.

Pinch protection system

-  Danger of jamming even with pinch protection

Even with the pinch protection system, check that the window's closing path is clear; otherwise, the closing action may not stop in certain situations, e.g., if thin objects are present. ◀

-  No window accessories
Do not install any accessories in the window's range of movement; otherwise, the pinch protection system will be impaired. ◀

If closing force exceeds a specific margin as a window closes, closing is interrupted.

The window reopens slightly.

Closing without the pinch protection system

-  Keep the closing path clear
Monitor closing and make sure that the closing path of the window is clear; otherwise, injuries may result. ◀

E.g. danger from the outside or ice might prevent window from closing properly - proceed as follows:

1. Pull the reel past the resistance point and hold it there.
The pinch protection is limited and the window reopens slightly if the closing force exceeds a certain margin.
2. Pull the reel past the resistance point again within approx. 4 seconds and hold it there.
The window closes without jam protection.

Glass sunroof, powered

General information

The glass sunroof is operational when the ignition is switched on.

 Keep the closing path clear

Monitor closing and make sure that the closing path of the glass sunroof is clear; otherwise, injuries may result. ◀

 Take the remote control with you

Take the remote control with you when leaving the vehicle so that children, e.g., cannot operate the glass sunroof and injure themselves. ◀



Tilting the glass sunroof

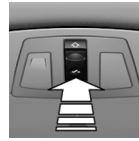

- Push switch briefly upward.
- ▷ The closed glass sunroof is tilted.
 - ▷ The opened glass sunroof closes until it is in its tilted position. The sliding visor does not move.

Opening/closing the glass sunroof and sliding visor together

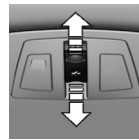

- ▷ Press the reel in the desired direction to the resistance point and hold it there.
The glass sunroof moves as long as the reel is held down.
 - ▷ Press the reel in the desired direction past the resistance point.
The glass sunroof moves automatically.
Pressing the reel upward stops the motion.
 - ▷ Open and close the sliding visors manually.
- Additional options:
- ▷ Convenient opening, refer to page 39, via the remote control.
 - ▷ Closing by means of Comfort Access, refer to page 44.

Comfort position

If the glass sunroof is not automatically completely opened, the comfort position has been attained. In this position the wind noises in the interior are the least.

If desired, continue the movement by pressing the reel.

Pinch protection system

If the glass sunroof while closing exceeds a certain value, the closing operation is interrupted at roughly the center of the roof opening.

The glass sunroof reopens slightly.

 Danger of jamming even with pinch protection

Despite the pinch protection system, check that the glass sunroof's closing path is clear; otherwise, the closing action may not be interrupted in certain extreme situations, such as when thin objects are present. ◀

Closing from the open position without pinch protection

E. g. if there is an external danger, proceed as follows:

1. Press the reel forward beyond the resistance point and hold.
The pinch protection is limited and the glass sunroof reopens slightly if the closing force exceeds a certain margin.
2. Press the reel forward again beyond the resistance point and hold until the glass sunroof closes without jam protection. Make sure that the closing area is clear.

Closing from the raised position without pinch protection

If there is an external danger, push the reel forward past the resistance point and hold it.

The glass sunroof closes without jam protection.

Initializing after a power failure

After a power failure during the opening or closing process, the glass sunroof can only be operated to a limited extent.

Initializing the system

The system can be initialized when the vehicle is stationary and drive readiness is established.

During the initialization, the glass sunroof closes without jam protection.



Keep the closing path clear

Monitor closing and make sure that the closing path of the glass sunroof is clear; otherwise, injuries may result. ◀

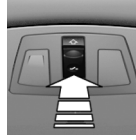

Press the reel up and hold it until the initialization is complete:

- ▶ Initialization begins within 15 seconds and is completed when the glass sunroof is completely closed.
- ▶ The glass sunroof closes without jam protection.

Adjusting

Vehicle features and options

This chapter describes all standard, country-specific and optional features offered with the series. It also describes features that are not necessarily available in your car, e. g., due to the selected options or country versions. This also applies to safety-related functions and systems.

Sitting safely

The ideal seating position can make a vital contribution to relaxed, fatigue-free driving.

The seating position plays an important role in an accident in combination with:

- ▷ Safety belts, refer to page 53.
- ▷ Head restraints, refer to page 54.
- ▷ Airbags, refer to page 92.

Seats

Hints

 Do not adjust the seat while driving
Do not adjust the driver's seat while driving, or the seat could respond with unexpected movement and the ensuing loss of vehicle control could lead to an accident. ◀

 Do not incline the backrest too far to the rear

Also on the front passenger side, do not incline the backrest on the front passenger side too far to the rear while driving, or there is a risk of slipping under the safety belt in the event of an accident. This would eliminate the protection normally provided by the belt. ◀



Keep the movement area unobstructed
When changing the seat position, keep the seat's area of movement unobstructed; otherwise, people might get injured or objects damaged. ◀

Adjusting seats

At a glance



- 1 Forward/backward 51
- 2 Height 52
- 3 Backrest tilt 52

Forward/backward

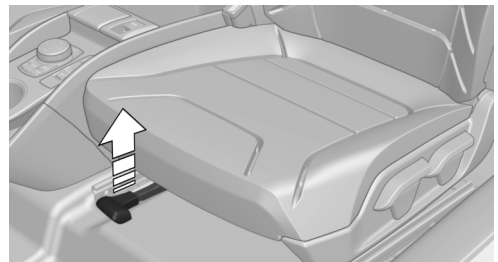

Pull the lever and slide the seat in the desired direction.

After releasing the lever, move the seat forward or back slightly making sure it engages properly.

Height

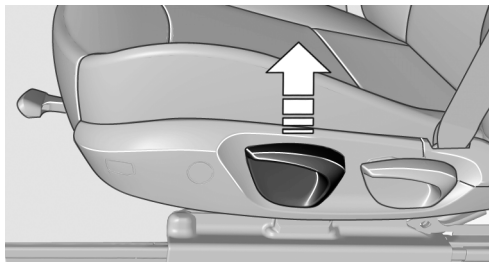

Pull the lever and apply your weight to the seat or lift it off, as necessary.

Backrest tilt

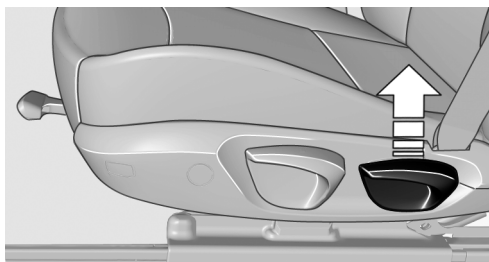

Pull the lever and apply your weight to the backrest or lift it off, as necessary.

Backrest

Note



Folding back and locking the backrest
Before driving off, fold back and lock the backrests; otherwise, an unexpected seat movement may cause an accident. ◀

Fold down seat back

1. Pull lever up to the stop.

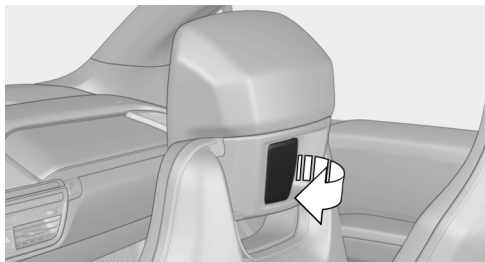

2. Fold backrest forward.

Backrest returns to its initial position after release.

Front seat heating



Switching on



Press button once for each temperature level.

The maximum temperature is reached when three LEDs are lit.

If the journey is continued within approx. 15 minutes, the seat heating is activated automatically with the temperature selected last.

If ECO PRO+, refer to page 151, is activated, the seat heating is deactivated.

Switch off



Press button longer.

The LEDs go out.

Safety belts

Seats with safety belt

The vehicle has four seats, each of which is equipped with a safety belt.

Number of safety belts

Your vehicle has been fitted with four safety belts for your and your passengers' safety. However, they can only offer protection when adjusted correctly.

General information

Always make sure that safety belts are being worn by all occupants before driving off.

For the occupants' safety the belt locking mechanism triggers early. Slowly guide the belt out of the holder when applying it.

Although airbags enhance safety by providing added protection, they are not a substitute for safety belts.

The upper shoulder strap's anchorage point will be correct for adult seat occupants of every build if the seat is correctly adjusted.

Hints

 One person per safety belt
Never allow more than one person to wear a single safety belt. Never allow infants or small children to ride on a passenger's lap. ◀

 Putting on the belt
Lay the belt, without twisting, snugly across the lap and shoulders, as close to the body as possible. Make sure that the belt lies low around the hips in the lap area and does not press on the abdomen. Otherwise, the belt can slip over the hips in a frontal impact and injure the abdomen.

The safety belt must not lie across the neck, rub on sharp edges, be routed over breakable objects, or be pinched. ◀

 What reduces the restraining effect
Avoid wearing bulky clothing, and pull the shoulder belt periodically to readjust the tension. Make sure that the belt is not jammed; otherwise, the belt can be damaged and the restraining effect is reduced. ◀

Buckling the belt

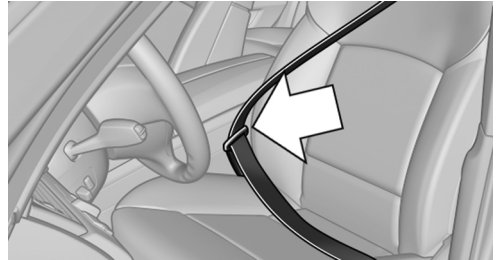

Make sure you hear the latch plate engage in the belt buckle.

Unbuckling the belt

1. Hold the belt firmly.
2. Press the red button in the belt buckle.
3. Guide the belt back into its roll-up mechanism.

Safety belt reminder for driver's and passenger's seat



The indicator lamp lights up and a signal sounds. Make sure that the safety belts are positioned correctly. The safety belt reminder is active at speeds above approx. 6 mph/10 km/h. It can also be activated if objects are placed on the front passenger seat.

Damage to safety belts

Wear and tear after accidents or when damaged otherwise:

Have the safety belts, including the safety belt tensioners, replaced and have the belt anchors checked.



Check and replace safety belts

This should only be done by your service center; otherwise, this safety feature might not work properly. ◀

Front head restraints

Distance

The spacing is adjusted to the back of the head using the incline of the seat backrest.

Adjust the distance so that the head restraint is as close as possible to the back of the head.

Removing

The head restraints cannot be removed.

Rear head restraints

Correctly adjusted head restraint

A correctly adjusted head restraint reduces the risk of injury to cervical vertebrae in the event of an accident.



Adjusting the head restraint

Adjust the head restraints of all occupied seats properly; otherwise, there is an increased risk of injury in an accident. ◀

Height

Adjust the head restraint so that its center is approximately at ear level.

Adjusting the height

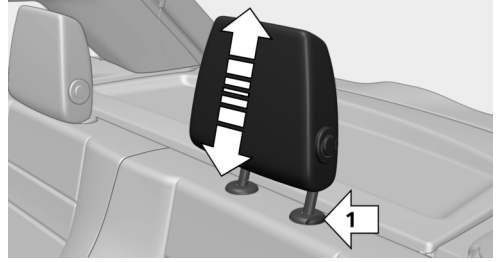

- ▷ To raise: push.
- ▷ To lower: press button, arrow 1, and push headrest down.

Folding down head restraints



Extending/retracting head restraint

Only fold down head restraint if no passengers are in the rear. Fold out retracted headrests again if passengers are being carried in the rear; otherwise, there is increased risk of injury in the event of an accident. ◀

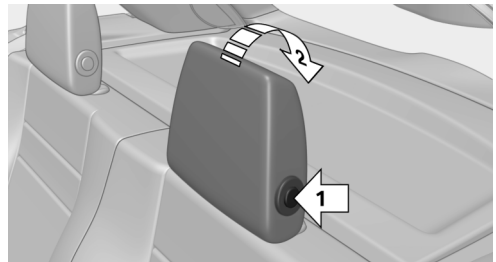

- ▷ To lower flaps: press the button, arrow 1, and press down the head restraint, arrow 2.
- ▷ Fold back up: pull up head restraints.

Removing

Only remove the head restraint if no one will be sitting in the seat in question.

Fold the seat down, refer to page 136, before removing the head restraint, otherwise the head restraint cannot be removed.

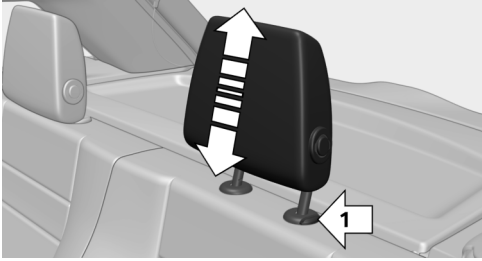

1. Raise the head restraint up against the resistance.
2. Press button, arrow 1, and pull the head restraint out completely.

 Before transporting passengers
Reinstall the head restraint before transporting anyone in the seat; otherwise, the protective function of the head restraint is unavailable. ◀

Mirrors

Exterior mirrors

General information

The mirror on the passenger side is more curved than the driver's side mirror.

Depending on the vehicle equipment, the mirror setting is stored for the profile currently in use. When the vehicle is unlocked via the remote control, the position is automatically retrieved if this function is active.

Note

 Estimating distances correctly
Objects reflected in the mirror are closer than they appear. Do not estimate the distance to the traffic behind you based on what you see in the mirror, as this will increase your risk of an accident. ◀

At a glance



- 1 Adjusting 55
- 2 Left/right, Automatic Curb Monitor, Automatic cornering adjustment
- 3 Fold in and out 56

Selecting a mirror

 To change over to the other mirror:
Slide the switch.

Adjusting electrically

 The setting corresponds to the direction in which the button is pressed.

Adjusting manually

In case of electrical malfunction press edges of mirror.

Automatic Curb Monitor

The concept

If reverse gear is engaged, the mirror glass on the front passenger side is tilted downward. This improves your view of the curb and other low-lying obstacles when parking, e.g.

Activating

1.  Slide the switch to the driver's side mirror position.
2. Engage selector lever position R.

Deactivating

Slide the switch to the passenger side mirror position.

Automatic cornering adjustment

The concept

During right-hand turns, the mirror glass is turned. Provides a better view of the vehicle sideways.

Note

 Personal responsibility

The system does not serve as a substitute for the driver's personal judgment of the traffic situation.

Be aware of the traffic situation and the vehicle's surroundings at all times, otherwise accidents are still possible depending on the situation. ◀

Requirements

- ▷ Vehicle moving.
- ▷ Speed less than 12 mph/20 km/h.
- ▷ Turn signal is set.

Activating

 Slide the switch to the driver's side mirror position.

Deactivating

Slide the switch to the passenger side mirror position.

Fold in and out

 Press button.

Possible at speeds up to approx. 15 mph/20 km/h.

E. g. this is advantageous

- ▷ In car washes.

- ▷ In narrow streets.
- ▷ For folding mirrors back out that were folded away manually.

Mirrors that were folded in are folded out automatically at a speed of approx. 25 mph/40 km/h.

 Fold in the mirror in a car wash
Before washing the car in an automatic car wash, fold in the exterior mirrors by hand or with the button; otherwise, the mirrors could be damaged, depending on the width of the vehicle. ◀

Automatic heating

Both exterior mirrors are automatically heated whenever drive readiness is switched on.

Automatic dimming feature

Both exterior mirrors are automatically dimmed. Photocells are used to control the Interior rearview mirror, refer to page 57.

Interior rearview mirror, manually dimmable

Flip lever

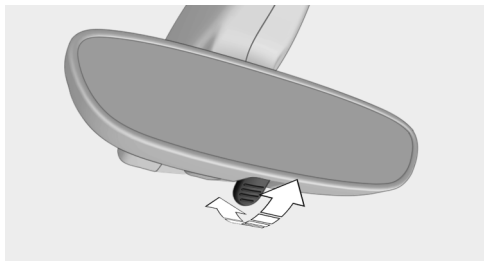

To reduce the blinding effect of the interior rear view mirror, flip the lever forward.

Interior rearview mirror, automatic dimming feature

The concept

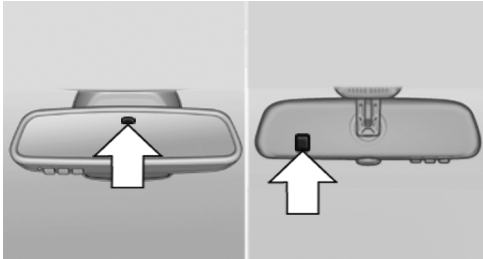

Photocells are used for control:

- ▷ In the mirror glass.
- ▷ On the back of the mirror.

Functional requirement

For proper operation:

- ▷ Keep the photocells clean.
- ▷ Do not cover the area between the inside rearview mirror and the windshield.

Steering wheel

Note



Do not adjust while driving

Do not adjust the steering wheel while driving; otherwise, an unexpected movement could result in an accident. ◀

Adjusting

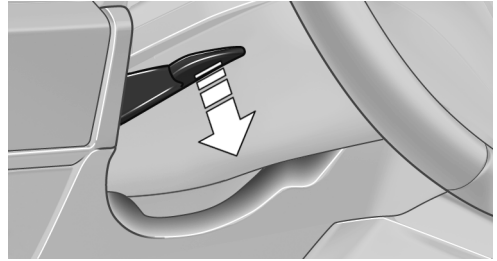

1. Fold the lever down.
2. Move the steering wheel to the preferred height and angle to suit your seating position.
3. Fold the lever back.

Transporting children safely

Vehicle features and options

This chapter describes all standard, country-specific and optional features offered with the series. It also describes features that are not

necessarily available in your car, e. g., due to the selected options or country versions. This also applies to safety-related functions and systems.

The right place for children

Note



Children in the vehicle

Do not leave children unattended in the vehicle; otherwise, they could endanger themselves and other persons, e.g., by opening the doors. ◀

Children should always be in the rear

Accident research shows that the safest place for children is in the back seat.



Transporting children in the rear

Only transport children younger than 13 years of age or shorter than 5 ft/150 cm in the rear in child restraint systems provided in accordance with the age, weight and size of the child; otherwise, there is an increased risk of injury in an accident.

Children 13 years of age or older must wear a safety belt as soon as a suitable child restraint system can no longer be used due to their age, weight and size. ◀

Children on the front passenger seat

Should it ever be necessary to use a child restraint system in the front passenger seat, make sure that the front, knee and side airbags on the front passenger side are deactivated. Automatic deactivation of front-seat passenger airbags, refer to page 94.

Note



Deactivating the front-seat passenger airbags

If a child restraint system is used in the front passenger seat, deactivate the front-seat passenger airbags; otherwise, there is an increased risk of injury to the child when the airbags are activated, even with a child restraint system. ◀

Installing child restraint systems

Hints



Manufacturer's information for child restraint systems

To select, mount and use child restraint systems, observe the information provided by the system manufacturer; otherwise, the protective effect can be lost. ◀



Ensuring the stability of the child seat

When installing child restraint systems, make sure that the child seat is securely fastened to the backrest of the seat. Angle and headrest of the backrest might need to be adjusted or possibly be removed. Make sure that all backrests are securely locked. Otherwise the stability of the child seat can be affected, and there is an increased risk of injury because

of unexpected movement of the rear seat backrest. ◀

On the front passenger seat

Deactivating airbags

 Deactivating the front-seat passenger airbags

If a child restraint system is used in the front passenger seat, deactivate the front-seat passenger airbags; otherwise, there is an increased risk of injury to the child when the airbags are activated, even with a child restraint system. ◀

After installing a child restraint system in the front passenger seat, make sure that the front, knee and side airbags on the front passenger side are deactivated.

Deactivate the front-seat passenger airbags automatically, refer to page 94.

Seat position and height

Before installing a child restraint system, move the front passenger seat as far back as possible and adjust its height to the highest and thus best possible position for the belt and to offer optimal protection in the event of an accident.

If the upper anchorage of the safety belt is located in front of the belt guide of the child seat, move the passenger seat carefully forward un-

til the best possible belt guide position is reached.

Child seat security



The rear safety belts and the front passenger safety belt can be permanently locked to fasten child restraint systems.

Locking the safety belt

1. Pull out the strap completely.
2. Secure the child restraint system with the belt.
3. Allow the strap to be pulled in and pull it tight against the child restraint system. The safety belt is locked.

Unlocking the safety belt

1. Unbuckle the belt buckle.
2. Remove the child restraint system.
3. Allow the strap to be pulled in completely.

LATCH child restraint system

LATCH: Lower Anchors and Tether for Children.

Note

 Follow manufacturer's information for LATCH child restraint systems

To mount and use the LATCH child restraint systems, observe the operating and safety information from the system manufacturer; oth-

erwise, the level of protection may be reduced. ◀

Mounts for the lower LATCH anchors

The lower anchors may be used to attach the CRS to the vehicle seat up to a combined child and CRS weight of 65 lb/30 kg when the child is restrained by the internal harnesses.



Properly engage the lower LATCH anchors

Make sure that the lower LATCH anchors have properly engaged and that the child restraint system is resting snugly against the backrest; otherwise, the degree of protection may be reduced. ◀

Before mounting the LATCH child restraint system, pull the belt away from the child restraint system.



The corresponding symbol shows the mounts for the lower LATCH anchors.



Position

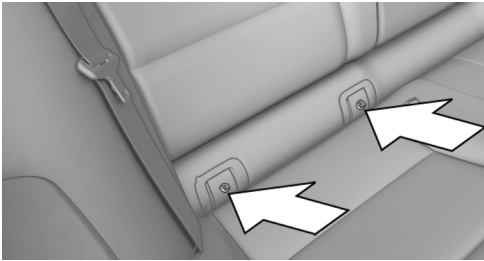

Attach to the lower LATCH anchors located behind the indicated covers.

Assembly of LATCH child restraint systems

1. Mount the child restraint system; refer to the user's manual of the system.
2. Ensure that both LATCH anchors are properly connected.

Child restraint fixing system with a tether strap

Mounting points

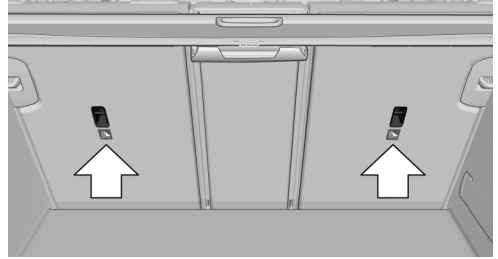

There are two mounting points on the rear seat backrest for child restraint systems with upper retaining strap.



The mounting point for the upper retaining strap is marked with a Top Tether symbol.

Note



Mounting eyelets

Use the mounting eyes only for the upper retaining strap to secure child restraint systems; otherwise, the mounting eyes could be damaged. ◀

Retaining strap guide



Retaining strap

Make sure that the upper retaining strap is not passed over the head restraints or sharp edges and is not twisted up to the upper mounting points; otherwise, the belt cannot properly secure the child restraint system in an accident. ◀

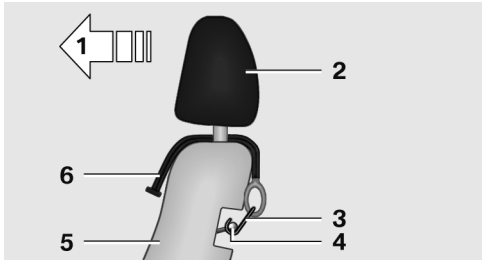

- 1 Direction of travel
- 2 Head restraint
- 3 Hook for upper retaining strap
- 4 Mounting point/eye
- 5 Seat backrest
- 6 Upper retaining strap

Attaching the upper retaining strap to the mounting point

1. Raise the head restraint if needed.
2. Guide the upper retaining strap between the supports of the head restraint.
3. If there is a retaining strap, run it between the backrest and the cargo cover.
4. Attach the hook of the retaining strap to the mounting eye.
5. Tighten the retaining strap by pulling it down.
6. Lower and lock head restraints as needed.

Driving

Vehicle features and options

This chapter describes all standard, country-specific and optional features offered with the series. It also describes features that are not necessarily available in your car, e. g., due to the selected options or country versions. This also applies to safety-related functions and systems.

Start/Stop button

At a glance

Button in the vehicle

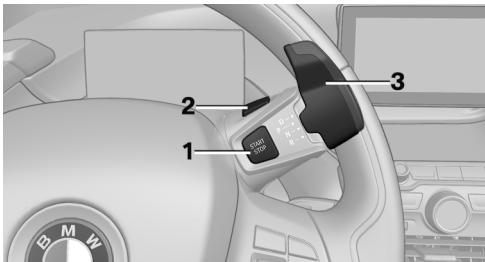

- 1 Start/Stop button
- 2 Park P
- 3 Selector lever

The concept



Pressing the Start/Stop button switches drive readiness on or off.

Drive readiness starts with the brake pedal pressed when you press the Start/Stop button.

Pressing the Start/Stop button again switches drive readiness back off and radio-ready state is switched back on.

Radio ready state

Some electronic systems/power consumers are ready for operation.

The radio-ready state is switched off automatically:

- ▷ After approx. 8 minutes.
- ▷ When the vehicle is locked using the central locking system.
- ▷ If the charging state of the batteries is low.

The radio-ready state remains active if, e.g., the drive readiness is automatically switched off for the following reasons:

- ▷ Opening or closing the driver's door.
- ▷ Unfastening of the driver's safety belt.
- ▷ When automatically switching from low beams to parking lights.

Radio ready state is switched back on if the on/off button on the radio is pressed when the vehicle is parked.

Operating readiness

All electronic systems/power consumers are ready for operation. Odometer and trip odometer are displayed in the instrument cluster.

To preserve the battery, use operating readiness and activated power features only as long as absolutely necessary.

Operating readiness is switched off:

- ▷ When locking the vehicle, even if the low beams are activated.
- ▷ When opening or closing the driver door, if the driver's safety belt is unbuckled and the low beams are turned off.
- ▷ While the driver's safety belt is unbuckled with driver's door open and low beams off.
- ▷ When the batteries' state of charge is low, if the low beams are turned off.

- ▷ The low beams reel to parking lights after approx. 15 minutes of no use.

Drive readiness

If drive readiness is switched on, the vehicle ready to drive and the READY signal, refer to page 63, is displayed in the instrument cluster.

All vehicle systems are ready for operation.

Most of the indicator and warning lights in the instrument cluster light up for a varied length of time.

Activated drive readiness is the equivalent of a running engine in conventional vehicles. Deactivated engine readiness is equivalent to switching the ignition off.

To save battery power when parking, reel off drive readiness and any unnecessary electronic systems/power consumers.

Drive readiness is switched off automatically:

- ▷ When opening or closing the driver door, if the driver's safety belt is unbuckled.

Note

If drive readiness is switched on, the system automatically switches to the radio-ready state when the door is opened and the driver's safety belt is unbuckled, or if the lights are turned off or the daytime running lights are activated.

- ⚠ Selector lever position P with drive readiness switched off

When drive readiness is switched off, selector lever position P is automatically engaged.

When in an automatic car wash, e.g., ensure that the drive readiness is not switched off accidentally, otherwise, wheels can lock up. ◀

Drive readiness in detail

Hints

- ⚠ Do not leave the vehicle unattended
- ⚠ Do not leave the vehicle unattended with drive readiness switched on; otherwise, it may pose a risk. ◀

- ⚠ Before leaving the vehicle
- Before leaving the vehicle, with drive readiness switched on engage lever in position P P and set the parking brake; otherwise, the vehicle is not secured against rolling away. ◀

Switching on drive readiness

1. Close the driver's door.
2. Depress the brake pedal.
3. Press the Start/Stop button.

Drive readiness is switched on.

Display in the instrument cluster

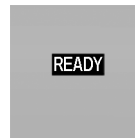

The READY display indicates that the vehicle is ready for driving.

Display on the Start/Stop button

General information

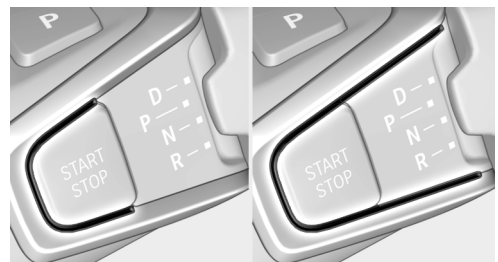

Drive readiness is also displayed through light indicators on the Start/Stop button.

Lighting pulses orange

- ▷ After unlocking and opening the door.
- ▷ After switching off drive readiness.

When the brake pedal is depressed, the lighting becomes more intense.

Lighting lights up steady blue

After drive readiness is switched on, light turns blue. The vehicle is ready to drive. The READY indicator lights up in the instrument cluster. In addition, a signal sounds.

Lighting off

Drive readiness, operating readiness and radio-ready state are turned off. The vehicle is in the idle state. The charging cable may be connected.

Driving off

Requirements

Driving is possible under the following conditions:

- ▷ The high-voltage battery is sufficiently charged.
- ▷ The driver's door is closed.

sDriving

1. Switch on drive readiness.
2. Apply the brake and engage lever in position P D or R.
3. Release the parking brake.
4. Depress the accelerator pedal to drive.

Selector lever positions

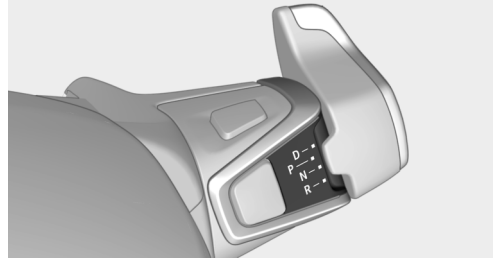

The engaged selector lever position is displayed on the selector lever.

D Drive

Position for normal vehicle operation.

R is Reverse

Select only when the vehicle is stationary.

N is Neutral

Use in automatic car washes, e.g. The vehicle may roll.

P Park

Engage only while the vehicle is stationary and the brake is applied. The drive wheels are blocked.

P is engaged automatically:

- ▷ If the belt on the driver's seat is off, the driver's door is open and neither brake nor accelerator pedal are depressed while drive readiness is switched on and selector lever position D or R is set.
- ▷ After switching off drive readiness via the Start/Stop button, if selector lever position D or R is set.
- ▷ With operating readiness turned off.

Before exiting the vehicle, make sure that selector lever position P is set. Otherwise, the vehicle may begin to move. On uphill slopes, also Set parking brake, refer to page 68.

Engaging selector lever positions

General information

- ▷ Interlock: the selector lever position P can be exited only with drive readiness engaged.
- ▷ Shift lock: with the vehicle stationary, press on the brake pedal before shifting out of P or N; otherwise, the shift command will not be executed.
- ▷ Shift lock: before shifting out of P, remove the charging cable from the vehicle; otherwise, the shift command will not be executed.

Engaging N, D, R

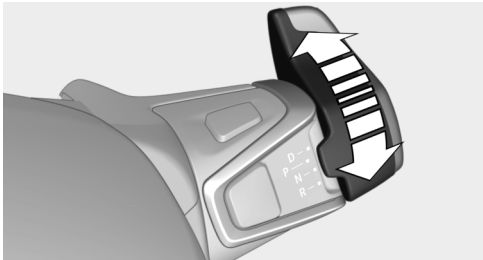

Turn the selector lever in the desired direction. The engaged selector lever position is displayed on the selector lever.

Engaging P

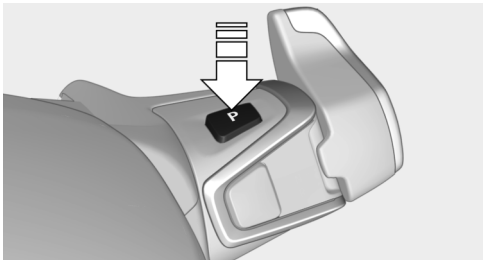

Press button P.

Electronic unlocking of the transmission lock

General information

Electronically unlock the transmission lock to maneuver vehicle from the danger area.

Unlocking is possible, if the started can spin the engine.

Engaging selector lever position N

1. Press and hold the Start/Stop button.
2. Depress the brake pedal.
3. Turn and hold the selector lever in position N.

A corresponding Check Control message is displayed.

4. Turn the selector lever again into position N within approx. 2 seconds. Position N is indicated on the selector lever.
5. Release Start/Stop button and brake.
6. Maneuver the vehicle from the danger area and secure it against moving on its own.

Switch off drive readiness

Park the car. Noises from the electrical system such as for cooling the high-voltage system might still be audible.

After stopping the vehicle:

1. Apply brake and engage lever in position P P.
2. Set the parking brake.
3. Press the Start/Stop button.

The READY indicator goes out and a signal sounds.

In case of longer idle times, follow the instructions in the Care chapter, refer to page 201.

Before driving into a car wash

So that the vehicle can roll into a car wash observe instructions for going into an automatic car wash, refer to page 198.

Driving in detail: eDRIVE

Hints

 Awareness of vehicle reduced when driven in electric mode

When driving in electric mode, note that, due to the lack of engine noise, pedestrians and other traffic might pay less attention to the vehicle due to missing engine noises. Please take special care when parking or leaving a parking space. ◀

 Cautiously remove your foot from the accelerator pedal

Cautiously remove your foot from the accelerator pedal because the braking effect of the electric motor can be stronger than with a combustion engine. Otherwise, abrupt braking and slow-down may confuse other traffic. ◀

Accelerator pedal positions

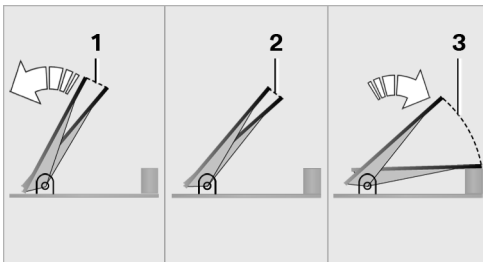

- 1 Deceleration
- 2 Coasting
- 3 Acceleration or constant speed: ePOWER

Deceleration

The deceleration depends on the position of the accelerator pedal. The less the actuation of

the accelerator pedal, the greater the deceleration. In this way energy is recovered and the high-voltage battery is charged.

Releasing the accelerator pedal causes deceleration similar to cautious braking. Additionally, the brake lights will come on without hitting the brakes.

Energy recovery: CHARGE

The high-voltage battery is recharged in part through energy recovery. The electric motor acts as a generator when decelerating and converts the kinetic energy into electrical energy.

Energy can be recovered if the following conditions are met:

- ▷ The vehicle is moving.
- ▷ Speed higher than approx. 12 mph/20 km/h.
- ▷ Selector lever position D or R is set.
- ▷ Gas pedal is not actuated or only pressed down 1/3 of the way.

Energy cannot be recovered in the following situations:

- ▷ Selector lever position N is set.
- ▷ While drive stability control systems, e.g. DTC, are active and control the vehicle, even though this is not indicated by an indicator light.
- ▷ The high-voltage battery is fully charged.
- ▷ When temperature of the high-voltage battery is very low or very high.

In winter it might be possible that the energy recovery is temporarily unavailable after startup.

 Always be ready to apply the brake
Always be ready to apply the brake, because without energy recovery there is also no braking action through the electric drive unit.

The vehicle could roll further than anticipated. This may constitute a danger for other traffic. ◀

Exemplary traffic situations

If a deceleration operation is foreseeable while driving, this can be used for energy recovery.

The following exemplary driving situations may show that:

- ▶ Decelerating downhill.
- ▶ Deceleration before a red light.

Avoid late or abrupt braking. Instead, decelerate the vehicle using energy recovery.

Coasting

The electric drive makes it possible to roll without consuming energy. This driving condition is referred to as coasting.

Proactive driving reduces energy consumption and increases the range.

With vehicle rolling, READY is displayed in the instrument cluster. With vehicle rolling, no energy is recovered.

Exemplary traffic situations

If a route can be traveled without anticipated need for braking, it is advantageous to roll.

The following exemplary driving situations may show that:

- ▶ Rolling on a straight downhill route without obstacles.
- ▶ Coasting on a route without obstacles.

Avoid late or abrupt braking.

Range Extender

Increase range

If the charging state of the high-voltage battery drops during travel to a minimum value, the Range Extender starts and supplies the required electrical energy for driving on.

∇ The symbol on the charging state indicator designates a Range Extender reel-on time.

The Range Extender controls its output automatically, turns itself off and restarts according to the driving situation.

The high-voltage battery will not be charged by the Range Extender.

Automatic maintenance run

To ensure that the Range Extender functions properly even during longer periods of non-use, the Range Extender is automatically activated for a few minutes at certain intervals during the trip. Respective Check Control messages indicate the dry run. Should that occur at an unfavorable time you may cancel the dry run by pressing the Start/Stop button. It postpones the dry run.

Should the high-voltage battery be fully charged or if there is not enough gas in the tank then a dry run will not be executed.

Heavily discharged high-voltage battery

If the high-voltage battery is heavily discharged during the trip, the performance and some comfort features are reduced step-by-step to extend the range.

Heated high-voltage battery

With a stationary dirt

In exceptional cases, it is possible that the high-voltage battery heats up sharply when the vehicle is stationary. E. g. with extreme external temperatures and direct solar radiation. With an overheated high-voltage battery, drive readiness cannot be switched on.

A Check Control message is displayed.

Another message will indicate when drive readiness is available again.

While driving

If the high-voltage battery overheats during the trip, the performance is reduced step-by-step in order to cool down the battery. The ePOWER performance display in the instrument cluster returns in the process. When temperature increases further, park the vehicle until the

high-voltage batter has cooled down. Should the performance display fall to 0, drive readiness is switched off and the vehicle comes to a stop.

Parking brake

The concept

The parking brake is used to prevent the vehicle from rolling when it is parked.





Setting

 Apply parking brake and further secure the vehicle if needed.

Set the parking brake firmly when parking; otherwise, the vehicle could roll. On steep upward and downward inclines, further secure the vehicle, e.g., by turning the steering wheel in the direction of the curb. ◀

 Take the remote control with you
Take the remote control with you when leaving the vehicle so that children, e.g., cannot release the parking brake. ◀

 Pull the reel.
The LED lights up.

 The indicator lamp lights up red. The parking brake is set.

While driving

Use as emergency brake while driving:

Pull the reel and hold it. The vehicle brakes hard while the reel is being pulled.

 The indicator lamp lights up red, a signal sounds and the brake lights light up.

A Check Control message is displayed.

If the vehicle is slowed down down to a speed of approx. 2 mph/3 km/h the parking brake is set.

Releasing

With drive readiness switched on:

 Press the reel while stepping on the brake pedal or selector lever position P is set.

The LED and indicator lamp go out.

The parking brake is released.

Automatic release

For automatic release, step on the accelerator pedal.

The LED and indicator lamp go out.

The parking brake is automatically released when you step on the accelerator:

- ▶ Drive readiness switched on.
- ▶ Drive mode engaged.
- ▶ Driver buckled in and doors closed.

 Inadvertent operation of the accelerator pedal

Make sure that the accelerator pedal is not operated unintentionally; otherwise, the vehicle is set in motion and there is a risk of an accident. ◀

Malfunction

In the event of a failure or malfunction of the parking brake, secure the vehicle against rolling using a wheel chock, e.g., when leaving it.

After a power failure

Putting the parking brake into operation

1. Switch on the ignition.
2.  Press the reel while stepping on the brake pedal or selector lever position P is set.

It may take several seconds for the brake to be put into operation. Any sounds associated with this are normal.

 The indicator lamp in the instrument cluster goes out as soon as the parking brake is ready for operation.

Hold function

The concept

The system holds the vehicle automatically when gear is engaged. This prevents rolling against the direction of travel.

In selector lever position D, the vehicle cannot roll backwards. In selector lever position R, it cannot roll forward. The brake pedal does not have to be pressed.

Hints

To reduce energy consumption when the hold function is activated, activate the parking brake or engage lever in position P P when the vehicle is stopped for long periods of time.

The hold function can be by the vehicle's load and the road incline. If needed a Check Control message will appear and position P will be selected automatically.

Turn signal, high beams, headlight flasher

Turn signal

Hints

 Do not adjust the exterior mirrors
Do not adjust the exterior mirror while driving and when blinker/hazards are on, or else the additional blinker lights in the exterior mirror are out of position and can't be seen. ◀

Using turn signals

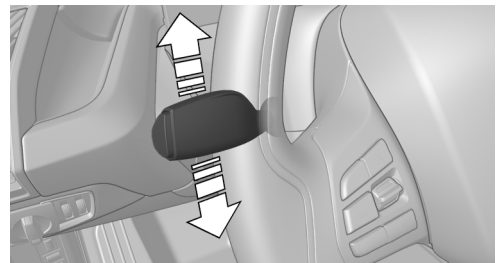

Press the lever beyond the resistance point.
To reel off manually, press the lever to the resistance point.

Unusually rapid flashing of the indicator lamp indicates that a turn signal bulb has failed.

Triple turn signal activation

Press the lever to the resistance point.
The turn signal flashes three times.
The function can be activated or deactivated.
On the Control Display:

1. "Settings"
2. "Lighting"
3. "Triple turn signal"

Settings are stored for the profile currently in use.

Signaling briefly

Press the lever to the resistance point and hold it there for as long as you want the turn signal to flash.

High beams, headlight flasher

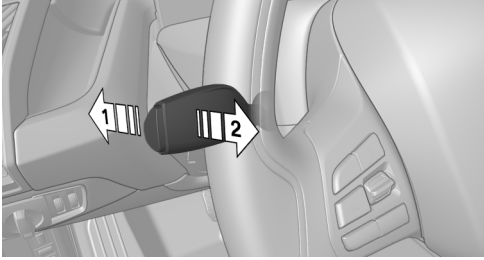

- ▷ High beams, arrow 1.
- ▷ Headlight flasher, arrow 2.

Washer/wiper system

Switching the wipers on/off and brief wipe

Hints

 Do not activate wipers if frozen to windshield

Do not reel on the wipers if they are frozen to the windshield; otherwise, the wiper blades and the wiper motor may be damaged. ◀

 Do not activate wipers on dry windshield
Do not use the wipers if the windshield is dry, as this may damage the wiper blades or cause them to become worn more quickly. ◀

Switching on

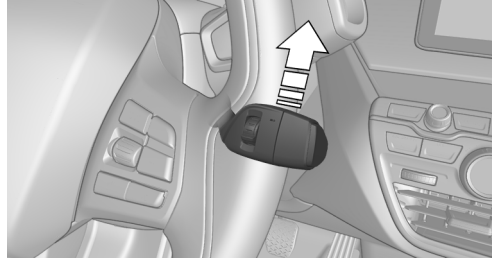

Push wiper lever up.

The lever automatically returns to its initial position when released.

- ▷ Normal wiper speed: push up once.
The wipers reel to intermittent operation when the vehicle is stationary.
- ▷ Fast wiper speed: press up twice or press once beyond the resistance point.
Wipers change to normal speed when vehicle comes to standstill.

Switch off and brief wipe

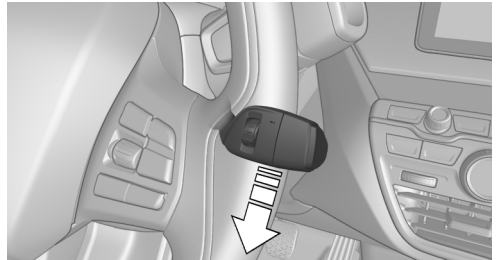

Push wiper lever down.

The lever automatically returns to its initial position when released.

- ▷ Single wipe: press down once.
- ▷ To reel off normal wipe: press down once.
- ▷ To reel off fast wipe: press down twice.

Intermittent operation or rain sensor

The concept

Without the rain sensor, the frequency of the wiper operation is preset.

The rain sensor automatically controls the time between wipes depending on the intensity of the rainfall. The sensor is located on the windshield, directly behind the interior rearview mirror.

Activating/deactivating

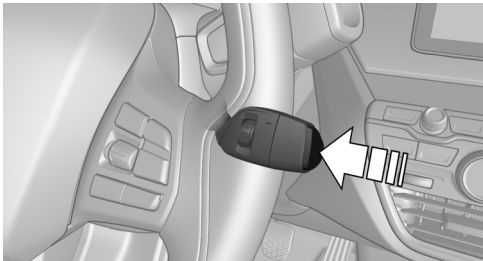

Press button on the wiper lever.

Wiping is started. If the vehicle is equipped with a rain sensor: LED in wiper lever lights up.

When wipers are frozen to windshield, wiper operation is deactivated.

 Deactivate the rain sensor in car washes
Deactivate the rain sensor when passing through an automatic car wash; otherwise, unintentional wiping can cause damages. ◀

Setting the frequency or sensitivity of the rain sensor

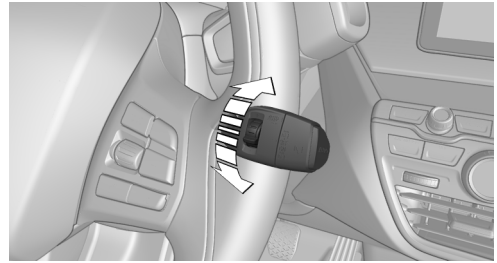

Turn the thumbwheel.

Clean the windshield

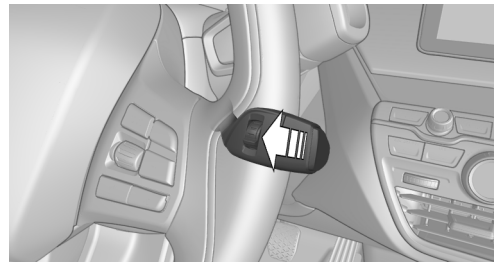

Pull the wiper lever towards you.

The system sprays washer fluid on the windshield and activates the wipers briefly.

 Do not use the washer system at freezing temperatures

Do not use the washers if fluid could freeze onto the windshield which might impede your viewing field. Therefore use antifreeze fluid.

Avoid using the washer when the reservoir is empty; operation might damage pump. ◀

Windshield washer nozzles

The windshield washer nozzles are automatically heated while operating readiness is switched on.

Rear window wiper

Switching on the rear window wiper

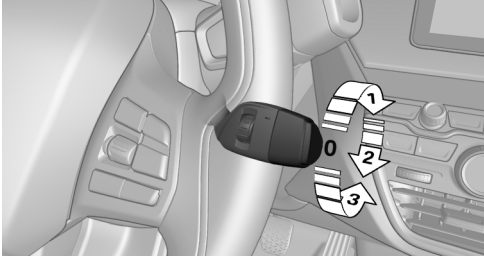

Turn the switch from idle position 0 upward, arrow 1: interval mode. When reverse gear is engaged, the system switches to continuous operation.

Cleaning rear window

In interval mode: turn the reel further, arrow 2. The reel automatically returns to its interval position when released.

In idle position: turn reel downward, arrow 3. The reel automatically returns to its idle position when released.

Fold-out position of the wipers

Fold wipers back when you want to change the blades or with pending low temperatures.

1. Switch operating readiness on and off again.
2. With icy conditions make sure that blades are not frozen to the windshield.
3. Press the wiper lever up beyond the point of resistance and hold it for approx. 3 seconds, until the wiper remains in a nearly vertical position.

After the wipers are folded back down, the wiper system must be reactivated.



Folding wipers back down

Before switching operating readiness on, fold the wipers back down to the windshield; otherwise, the wipers may become damaged when they are activated. ◀

1. Turn on operations.
2. Push wiper lever down. Wipers move to their resting position and are ready again for operation.

Washer fluid

General information



Antifreeze for washer fluid

Antifreeze is flammable and can cause injury if it is used incorrectly.

Therefore, keep it away from possible sources of ignition.

Only keep it in the closed original container and inaccessible to children.

Follow the notes and instructions on the container.

United States: The washer fluid mixture ratio is regulated by the U.S. EPA and many individual states; do not exceed the allowable washer fluid dilution ratios limits that apply. Follow the usage instructions on the washer fluid container. Use BMW's Windshield Washer Concentrate or the equivalent. ◀

Washer fluid reservoir

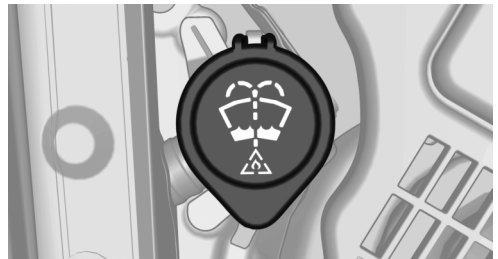

All washer nozzles are supplied from one reservoir.

Fill with a mixture of windshield washer concentrate and tap water and – if required – with a washer antifreeze, according to the manufacturer's recommendations.

Mix the washer fluid before adding to find the right mixture.

Do not add windshield washer concentrate and antifreeze undiluted and do not fill with pure water; this could damage the wiper system.

Do not mix window washer concentrates of different manufacturers because they can clog the windshield washer nozzles.

Recommended minimum fill quantity:
0.2 US gal/1 liter.

Displays

Vehicle features and options

This chapter describes all standard, country-specific and optional features offered with the series. It also describes features that are not

necessarily available in your car, e. g., due to the selected options or country versions. This also applies to safety-related functions and systems.

Instrument cluster

The concept

The instrument cluster is a variable display. Some of the displays in the instrument cluster

may differ from the way they are shown in this Owner's Handbook.

At a glance

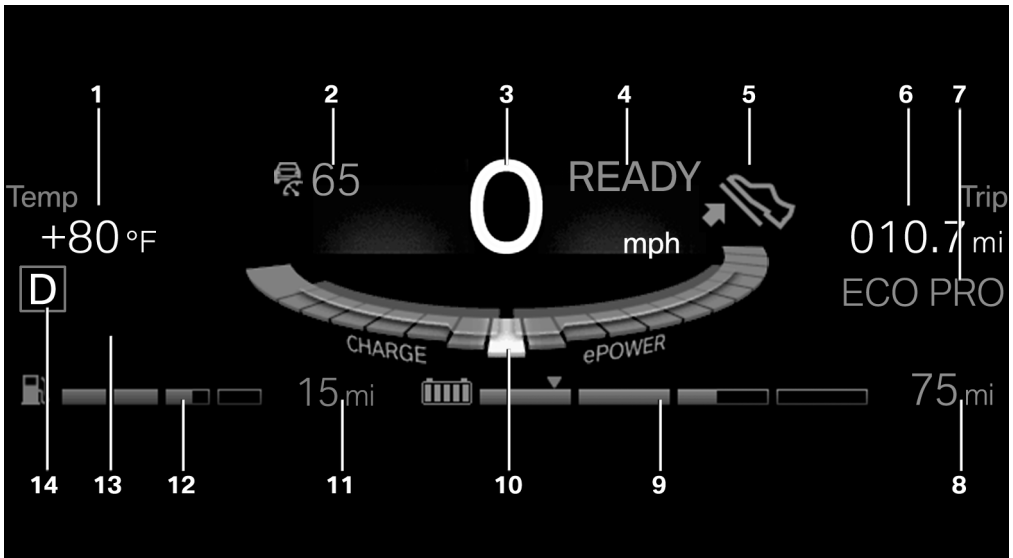

- | | |
|---|--|
| 1 Computer 85 | 8 Range for electric driving 82 |
| 2 Driver assistance systems | 9 Battery charge indicator 76 |
| 3 Speedometer | 10 Performance display 76 |
| 4 Drive readiness indicator 63 | Selection list, such as for the radio 84 |
| 5 ECO PRO tips 151 | 11 Range Extender range 82 |
| 6 Trip odometer 81 | 12 Range Extender fuel gauge 81 |
| 7 Driving Dynamics Control program 107 | 13 Messages, e.g. Check Control |

14 Display, drive mode 64

Charging screen

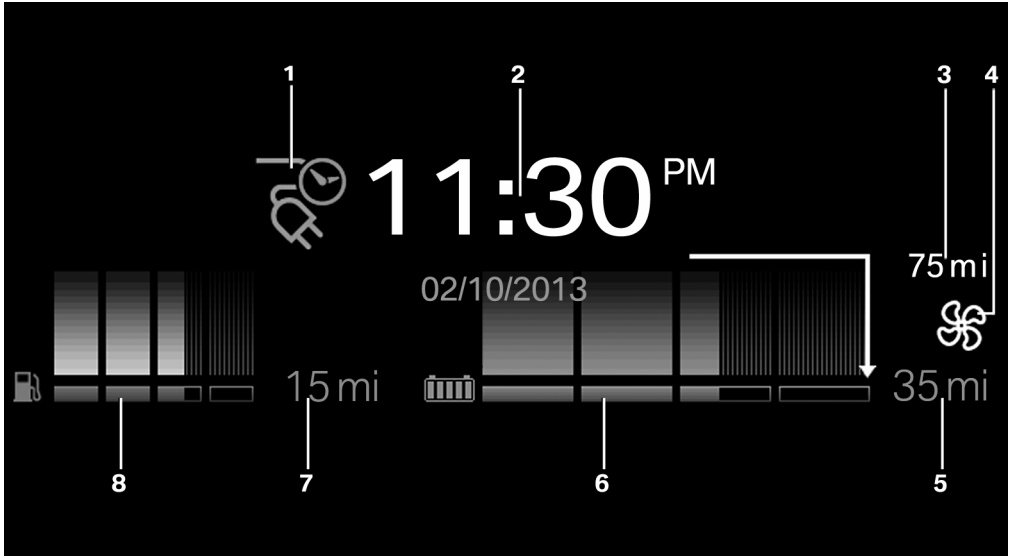

- | | | | | | |
|---|----------------------------|-----|---|---------------------------------|-----|
| 1 | Charging screen | 162 | 5 | Range for electric driving | 162 |
| 2 | End of charging time | 162 | 6 | Charging state | 76 |
| | Departure time with timer | 163 | 7 | Range Extender range | 82 |
| 3 | Maximum electrical range | 162 | 8 | With Range Extender: fuel gauge | 81 |
| 4 | Stationary climate control | 163 | | | |

Displaying the eDRIVE system

- ▶ Drive readiness: READY.

Displays in the instrument cluster

The concept

The display depends on the system's operating condition. The following functions of the eDRIVE system are shown in the instrument cluster:

- ▶ High-voltage battery charge indicator.
- ▶ Electric driving: ePOWER.
- ▶ Energy recovery: CHARGE.

High-voltage battery charge indicator

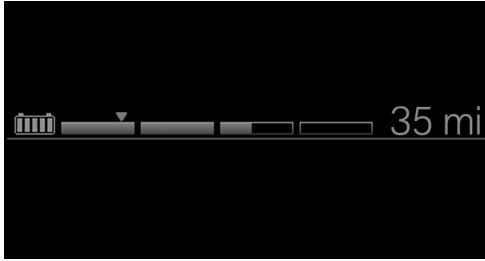

High voltage

Even if no bars are displayed in the battery symbol, the high-voltage system is still under high voltage. ◀

The fill level bars indicate the available charging state of the high-voltage battery when operating readiness and drive readiness are switched on.

With a low range the color of the charging status indicator switches from blue to yellow.

In addition, the range for electric driving is displayed.

With Range Extender: maintaining charging state

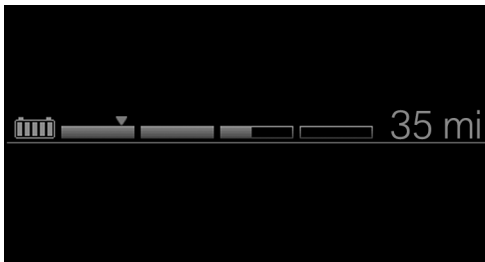

▽ The arrow on the charging state indicator designates the Range Extender reel-on time. If Range Extender is activated, the current charging state of the high-voltage battery is maintained.

- ▷ Gray arrow: Range Extender deactivated.
- ▷ White arrow: Range Extender activated.

Manual activating/deactivating the Maintaining charging state function.

Performance display

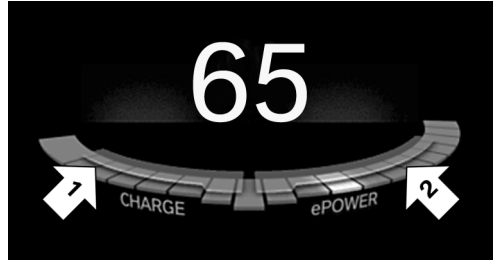

The accelerator pedal indicator in the performance display indicates the current efficiency of the driving style. The efficient range of the performance display is colored blue.

Accelerator pedal indicator in the CHARGE range, arrow 1: display for energy recovered by coasting or when decelerating.

Accelerator pedal indicator in the ePOWER range, arrow 2: display when accelerating.

Use eDRIVE efficiently, refer to page 144.

Drive readiness: READY

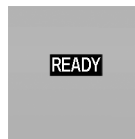

The READY display indicates that the vehicle is ready for driving. Drive readiness in detail, refer to page 63.

Indications on the Control Display

Fuel consumption history

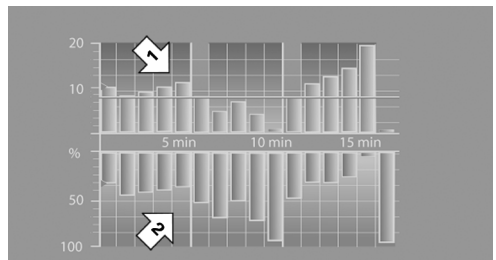

The top bars indicate the average energy consumed while driving time, arrow 1. The lower bars indicate the average energy recovered while driving time, arrow 2.

One bar indicates one minute.

The eDRIVE system's average fuel consumption is indicated by a line above the bar display and as a value on the right next to the graph.

Displaying fuel consumption history

1. "Vehicle info"
2. "eDRIVE"
3.  "CHARGE"

Energy flow of the eDRIVE system

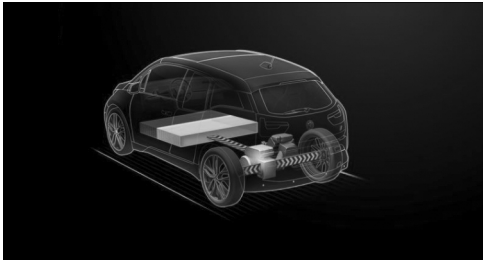

The display shows the active components of the eDRIVE system:

- ▷ Blue: electrical energy.
- ▷ Arrow: direction of the energy flow.
- ▷ Segments of the high-voltage battery symbolize the charging state.
- ▷ The operating states are displayed: "ePOWER", "CHARGE".
- ▷ Interior cooling/heating function switched on.

Displaying the energy flow

1. "Vehicle info"
2. "eDRIVE"
3.  "Energy flow"

Energy distribution

Beside the current range the display shows the energy distribution and the potential range if individual secondary functions are turned off.

- ▷ Blue: electrical energy
- ▷ White: activated secondary functions.

Displaying energy distribution

1. "Vehicle info"
2. "eDRIVE"
3.  "Comfort information"

Check Control

The concept

The Check Control system monitors functions in the vehicle and notifies you of malfunctions in the monitored systems.

A Check Control message is displayed as a combination of indicator or warning lights and text messages in the instrument cluster.

In addition, an acoustic signal may sound and a text message may appear on the Control Display.

Indicator/warning lights

General information

The indicator and warning lights in the instrument cluster can light up in a variety of combinations and colors.

Several lights indicate function checks and light up only temporarily when drive readiness or operating readiness are activated.

Red lights

Safety belt reminder



Flashing or illuminated: safety belt on the driver or passenger side is not buckled. The safety belt reminder can

also be activated if objects are placed on the front passenger seat.

Make sure that the safety belts are positioned correctly.

Airbag system



Airbag system and belt tensioner are defective.

Have the vehicle checked by the service center immediately.

Parking brake



The parking brake is set.

For additional information, refer to Release parking brake, refer to page 68.

Brake system



Continue to drive moderately.

Have the vehicle checked by the service center immediately.



Front-end collision warning



Illuminated: advance warning is issued, e.g., when there is the impending danger of a collision or the distance to the vehicle ahead is too small.

Increase distance.

Flashing: acute warning of the imminent danger of a collision when the vehicle approaches another vehicle at a relatively high differential speed.

Intervention by braking or make an evasive maneuver.

Pedestrian warning



If a collision with a person detected in this way is imminent, the symbol lights up and a signal sounds.

Orange lights

Active Cruise Control



The number bars shows the selected distance from the vehicle driving ahead.

For additional information, refer to Active Cruise Control with Stop & Go function, ACC, refer to page 109.

Vehicle detection, Active Cruise Control



Illuminated: vehicle driving ahead detected.

Flashing: the conditions are not adequate for operating the system.

The system was deactivated but applies the brakes until you actively resume control by pressing on the brake pedal or accelerator pedal.

Yellow lights

Antilock Brake System ABS



It reduces the braking distance to a minimum during emergency stops.



Illuminated: avoid abrupt braking if possible. Braking force boost in some cases defective. Stop carefully. Take into account longer brake travel. Have this checked by the service center immediately.

DSC Dynamic Stability Control



Flashing: DSC controls the drive and braking forces. The vehicle is stabilized. Reduce speed and adapt driving profile to the driving circumstances.

Illuminated: DSC failed. Have the system checked by the service center.

For additional information, refer to Dynamic Stability Control DSC, refer to page 106.

DSC Dynamic Stability Control is deactivated or DTC Dynamic Traction Control is activated



Dynamic Stability Control DSC is switched off or Dynamic Traction Control DTC is switched on.

For additional information, refer to Dynamic Stability Control, refer to page 106, and Dynamic Traction Control, refer to page 107.

FTM Flat Tire Monitor



The Flat Tire Monitor signals a loss of tire inflation pressure in a tire.

Reduce your speed and stop cautiously. Avoid sudden braking and steering maneuvers.

For more information, see Flat Tire Monitor, refer to page 98.

Tire Pressure Monitor TPM



Illuminated: the Tire Pressure Monitor signals a loss of tire inflation pressure in a tire.

Reduce your speed and stop cautiously. Avoid sudden braking and steering maneuvers.

Flashing and then continuously illuminated: no flat tire or loss of tire inflation pressure can be detected.

- ▷ Interference through systems or devices with the same radio frequency: after leaving the area of the interference, the system automatically becomes active again.
- ▷ RDC could not conclude the reset: perform the reset of the system again.
- ▷ A wheel without TPM electronics is fitted: have the service center check it if needed.

- ▷ Malfunction: have the system checked by your service center.

For more information, see Tire Pressure Monitor, refer to page 95.

Steering system



Steering system in some cases defective.

Have the steering system checked by the service center.

Engine functions



Have the vehicle checked by the service center.

For additional information, refer to On-board Diagnostics socket, refer to page 186.

Green lights

Turn signal



Turn signal on.

Unusually rapid flashing of the indicator lamp indicates that a turn signal bulb has failed.

For additional information, refer to Turn signal, refer to page 69.

Parking lights, headlight control



Parking lights or headlights are activated.

For additional information, refer to Parking lights/low beams, headlight control, refer to page 89.

Cruise control



The system is switched on. It maintains the speed that was set using the control elements on the steering wheel.

Blue lights

High beams



High beams are activated.

For additional information, refer to High beams, refer to page 70.

General lamps

Check Control



At least one Check Control message is displayed or is stored (symbol in display).

Text messages

Text messages in combination with a symbol in the instrument cluster explain a Check Control message and the meaning of the indicator and warning lights.



Supplementary text messages

Additional information, such as on the cause of an error or the required action, can be called up via Check Control.

With urgent messages the added text will be automatically displayed on the Control Display.

Symbols

Depending on the Check Control message, the following functions can be selected.

- ▷  "Owner's Manual"
Display additional information about the Check Control message in the Integrated Owner's Manual.
- ▷  "Service request"
Contact your service center.
- ▷  "Roadside Assistance"
Contact Roadside Assistance.

Hiding Check Control messages

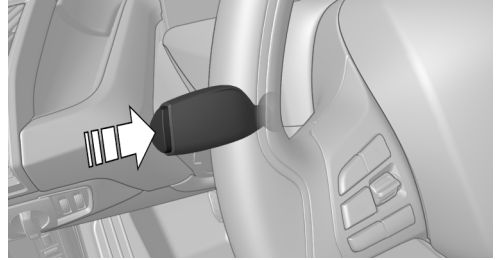

Press the onboard computer button on the turn signal lever.

- ▷ Some Check Control messages are displayed continuously and are not cleared until the malfunction is eliminated. If several malfunctions occur at once, the messages are displayed consecutively.

These messages can be faded for approx. 8 seconds. After this time, they are displayed again automatically.

- ▷ Other Check Control messages are faded automatically after approx. 20 seconds. They are stored and can be displayed again later.

Displaying stored Check Control messages

On the Control Display:

1. "Vehicle info"
2. "Vehicle status"
3.  "Check Control"
4. Select the text message.

Messages after trip completion

Special messages displayed while driving are displayed again after drive readiness is switched off.

With Range Extender: fuel gauge

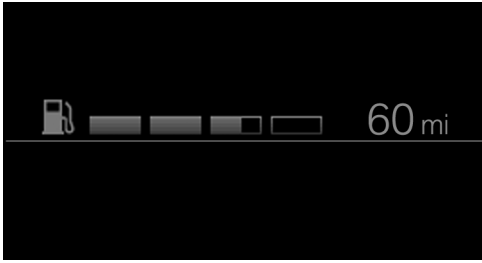

The fill level bars indicate the available fuel supply of the Range Extender when operating readiness and drive readiness are switched on.

Additional range of the Range Extender on top of pure electric range. If the Range Extender is activated, the color of the fill level bar indicator switches from gray to white.

Vehicle tilt position may cause the display to vary.

Hints on refueling, refer to page 165.

Coolant temperature

If the coolant along with the engine becomes too hot, a Check Control message is displayed.

Check the coolant level, refer to page 183.

Odometer and trip odometer

Display

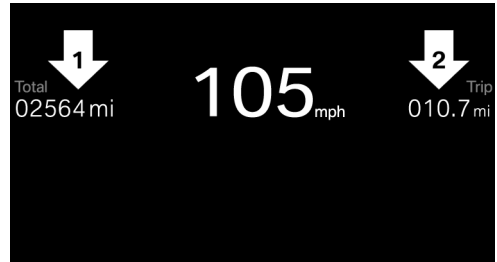

- ▷ Odometer, arrow 1, Scope of the on-board computer, refer to page 85.
- ▷ Trip odometer, arrow 2.

Show/reset kilometers: TRIP

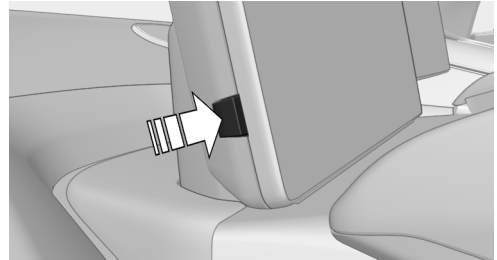

Press the knob.

- ▷ With operating readiness turned off, the time, the external temperature and the odometer are displayed.
- ▷ When operating readiness is switched on, the trip odometer is reset.

External temperature

If the indicator drops to +37 °F/+3 °C or lower, a signal sounds.

A Check Control message is displayed.

There is an increased risk of ice on roads.



Ice on roads

Even at temperatures above +37 °F/+3 °C, roads might be icy.

Therefore, drive carefully on bridges and shaded roads, e.g., to avoid the increased risk of an accident. ◀

Time

The time is displayed in the computer.

Setting the time and time format, refer to page 87.

Range

The expected range for the energy stored in the high-voltage battery is displayed on the right side of the instrument cluster next to the charging state indicator of the high-voltage battery.

With Range Extender:

The range of the Range Extender is displayed separately next to the fuel gauge. The total range can be displayed via the on-board computer. Expanding the range with Range Extender, refer to page 67.

Two Check Control messages indicate a limited range.

The range display is dynamic.

The range can be abruptly reduced or increased based on the following factors:

- ▷ Driving style.
- ▷ Traffic conditions.
- ▷ Program change via Driving Dynamics Control.
- ▷ Climate and terrain conditions.
- ▷ Automatic climate control settings.
- ▷ After determination of a route by the navigation system.
- ▷ When exiting a route or recalculating a route.

Hints



Observe range

Always make sure that the range is sufficient for the planned trip. The range is dynamic and can abruptly change. ◀

Increase range, refer to page 144.

Service requirements

The concept

The driving distance or the time to the next scheduled maintenance is displayed briefly in the instrument cluster after operating readiness is switched on.

Your service specialist can read the current service requirements from your remote control.

Display

Data regarding the service status or legally mandated vehicle inspections are automatically transmitted to your service center before a service due date.



Detailed information on service requirements

More information on the scope of service required can be displayed on the Control Display.

On the Control Display:

1. "Vehicle info"
2. "Vehicle status"
3.  "Service required"
Required maintenance procedures and legally mandated inspections are displayed.
4. Select an entry to call up detailed information.

Symbols

Symbols	Description
	No service is currently required.
	The deadline for scheduled maintenance or a legally mandated inspection is approaching.
	The service deadline has already passed.

Entering appointment dates

Enter the dates for the required inspections.

Make sure that the vehicle's date and time are set correctly.

On the Control Display:

1. "Vehicle info"
2. "Vehicle status"
3.  "Service required"
4. "§ Vehicle inspection"
5. "Date:"
6. Adjust the settings.
7. Confirm.

The entered date is stored.

Automatic Service Request

Data regarding the service status or legally mandated vehicle inspections are automatically transmitted to your service center before a service due date.

You can check when your service center was notified.

On the Control Display:

1. "Vehicle info"
2. "Vehicle status"
3. Open "Options".
4. "Last Service Request"

Speed limit detection

The concept

Speed limit detection

Speed limit detection uses a symbol in the shape of a traffic sign to display the currently detected speed limit. The camera in the area of the interior rearview mirror detects traffic signs at the edge of the road as well as variable overhead sign posts. Traffic signs with extra symbols for wet road conditions, etc. are also detected and compared with the vehicle's onboard data, such as for the rain sensor, and will be displayed depending on the situation. The system takes into account the information stored in the navigation system and also displays speed limits present on routes without signs.

Hints



Personal judgment

The system cannot serve as a substitute for the driver's personal judgment of the traffic situation.

The system assists the driver and does not replace the human eye. ◀

At a glance

Camera

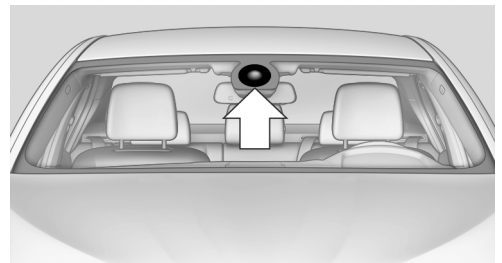

The camera is found near the interior rearview mirror.

Keep the windshield in the area behind the interior rearview mirror clean and clear.

Switching on/off

On the Control Display:

1. "Settings"
2. "Instrument cluster"
3. "Speed limit information"

If speed limit detection is switched on, it can be displayed on the info display in the instrument cluster.

Display

The following is displayed in the instrument cluster:

Speed limit detection



Current speed limit.



Speed limit detection is not available.

System limits

The system may not be fully functional and may provide incorrect information in the following situations:

- ▷ In heavy fog, rain or snowfall.
- ▷ When signs are concealed by objects.
- ▷ When driving very close to the vehicle in front of you.
- ▷ When driving toward bright lights.
- ▷ When the windshield behind the interior rearview mirror is fogged over, dirty or covered by a sticker, etc.

- ▷ In the event of incorrect detection by the camera.
- ▷ If the speed limits stored in the navigation system are incorrect.
- ▷ In areas not covered by the navigation system.
- ▷ When roads differ from the navigation, such as due to changes in road routing.
- ▷ When passing buses or trucks with a speed sticker.
- ▷ If the traffic signs are non-conforming.
- ▷ During calibration of the camera immediately after vehicle shipment.

Selection lists in the instrument cluster

The concept

Depending on your vehicle's optional features, the following can be displayed or operated using the buttons and the thumbwheel on the steering wheel and the display in the instrument cluster:

- ▷ Current audio source.
- ▷ Redial phone feature.
- ▷ Turn on voice activation system.

It also displays programs of the Driving Dynamics Control.

Display



Depending on your vehicle's optional features, the list in the instrument cluster can differ from the illustration shown.

Activating a list and adjusting the setting

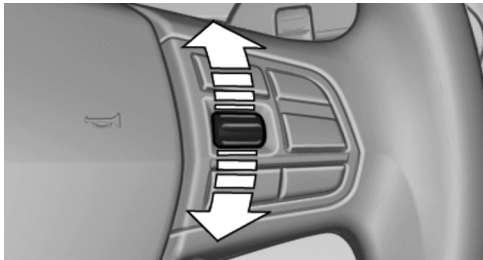

On the right side of the steering wheel, turn the thumbwheel to activate the corresponding list.

Using the thumbwheel, select the desired setting and confirm it by pushing the thumbwheel.

Computer

Display in the instrument cluster

The information from the computer is shown in the upper left area of the instrument cluster.

Calling up information on the info display

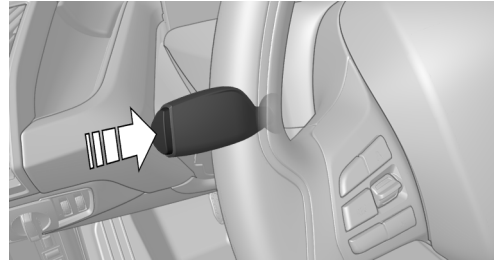

Press the onboard computer button on the turn signal lever.

Information is displayed in the info display of the instrument cluster.

Information at a glance

Repeatedly pressing the button on the turn signal lever calls up the following information in the info display:

- ▷ Kilometers.
- ▷ With Range Extender: total range
- ▷ Average fuel consumption.
- ▷ Current fuel consumption.
- ▷ Average speed.
- ▷ External temperature.
- ▷ Time.
- ▷ Speed limit detection.

Adjusting displays for computer

You can select what information from the computer is to be displayed in the instrument cluster.

On the Control Display:

1. "Settings"
2. "Instrument cluster"
3. Select the desired displays.

Information in detail

With Range Extender: total range

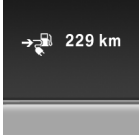

The total range considers the capacity of the fuel tank as well as the electric energy in the high-voltage battery.

Average fuel consumption

The average fuel consumption is calculated on the basis of various distances. Standstill with drive readiness turned off is not considered.

Current fuel consumption

Displays the current energy consumption. The efficiency of the driving can be monitored.

Average speed

Periods when vehicle is parked with drive readiness switched off are not included when calculating average speed.

Resetting average values

Press and hold the onboard computer button on the turn signal lever.

Speed limit detection

Description of the speed limit detection, refer to page 83, function.

Trip computer

The vehicle features two types of board computers.

- ▷ "Onboard info": the values can be reset as often as necessary.
- ▷ "Trip computer": the values provide an overview of the current trip.

Resetting the trip computer

On the Control Display:

1. "Vehicle info"

2. "Trip computer"

3. "Reset": all values are reset.

"Automatically reset": all values are reset approx. 4 hours after the vehicle came to a standstill.

Display on the Control Display

Display the computer or trip computer on the Control Display.

1. "Vehicle info"
2. "Onboard info" or "Trip computer"

Resetting the fuel consumption or speed

On the Control Display:

1. "Vehicle info"
2. "Onboard info"
3. "Consumpt." or "Speed"
4. "Yes"

Speed warning

The concept

Displays a speed, when reached, should cause a warning to be issued.

The warning is repeated if the vehicle speed drops below the set speed once by at least 3 mph/5 km/h.

Displaying, setting or changing the speed warning

On the Control Display:

1. "Settings"
 2. "Speed"
 3. "Warning at:"
 4. Turn the controller until the desired speed is displayed.
 5. Press the controller.
- Speed warning is stored.

Activating/deactivating the speed warning

On the Control Display:

1. "Settings"
2. "Speed"
3. "Warning"
4. Press the controller.

Setting your current speed as the speed warning

On the Control Display:

1. "Settings"
2. "Speed"
3. "Select current speed"
4. Press the controller.
The current vehicle speed is stored as the speed warning.

Settings on the Control Display

Time

Setting the time

1. "Settings"
2. "Time/Date"
3. "Time:"
4. Turn the controller until the desired hours are displayed.
5. Press the controller.
6. Turn the controller until the desired minutes are displayed.
7. Press the controller.

The time is stored.

Setting the time format

1. "Settings"
2. "Time/Date"

3. "Format:"
4. Select the desired format.
The time format is stored.

Automatic time setting

Depending on your vehicle's optional features, the time, date and, if needed, the time zone are updated automatically.

1. "Settings"
2. "Time/Date"
3. "Auto time set"

Date

Setting the date

1. "Settings"
2. "Time/Date"
3. "Date:"
4. Turn the controller until the desired day is displayed.
5. Press the controller.
6. Make the necessary settings for the month and year.

The date is stored.

Setting the date format

1. "Settings"
2. "Time/Date"
3. "Format:"
4. Select the desired format.
The date format is stored.

Language

Setting the language

To set the language on the Control Display:

1. "Settings"
2. "Language/Units"
3. "Language:"
4. Select the desired language.

Settings are stored for the profile currently in use.

2. "GPS tracking"
3. "GPS tracking"

Setting the voice dialog

Voice dialog for the voice activation system, refer to page 27.

Units of measure

Setting the units of measure

To set the units for fuel consumption, route/distance and temperature:

1. "Settings"
2. "Language/Units"
3. Select the desired menu item.
4. Select the desired unit.

Settings are stored for the profile currently in use.

Brightness

Setting the brightness

To set the brightness of the Control Display:

1. "Settings"
2. "Control display"
3. "Brightness"
4. Turn the controller until the desired brightness is set.
5. Press the controller.

Settings are stored for the profile currently in use.

Depending on the light conditions, the brightness settings may not be clearly visible.

Activating/deactivating display of the current vehicle position

If GPS geolocation has been activated, the current vehicle position can be displayed in the BMW i Remote App or in the ConnectedDrive customer portal.

1. "Settings"

Lights

Vehicle features and options

This chapter describes all standard, country-specific and optional features offered with the series. It also describes features that are not necessarily available in your car, e. g., due to the selected options or country versions. This also applies to safety-related functions and systems.

At a glance



- 1 Rear fog lights
- 2 Depending on the equipment: automatic headlamp control, welcome lamps, daytime running lights
- 3 Lights off, daytime running lights
- 4 Parking lights/daytime running lights
- 5 Low beams/welcome lights
- 6 Headlight range control
- 7 Instrument lighting



Parking lights/low beams, headlight control

General information

Position of switch: 0, , 

With driver's door open and operating readiness turned off, the exterior lighting will be turned off automatically.

Parking lights

Position of switch   : the vehicle's lights light up on all sides, e.g., for parking.



Do not use the parking lights for extended periods; otherwise, they might drain the battery and disable drive readiness.

When parking, it is preferable to reel on the one-sided roadside parking lights, refer to page 90.

Low beams

Position of switch  with operating readiness switched on: the low beams light up.

Welcome lights

When the vehicle is parked, leave the reel in position  or  : parking and interior lights come on briefly when the vehicle is unlocked depending on the ambient brightness.

Activating/deactivating

On the Control Display:

1. "Settings"
2. "Lighting"
3. "Welcome lights"

Settings are stored for the profile currently in use.

Headlight courtesy delay feature

The low beams stay lit for a short while if the headlight flasher is switched on after the radio-ready state is switched off.

Setting the duration

On the Control Display:

1. "Settings"
2. "Lighting"
3. "Pathway lighting:"
4. Set length of time.

Settings are stored for the profile currently in use.

Automatic headlight control

Position of switch : the low beams are activated and off automatically, e.g., in tunnels, in twilight or if there is precipitation. The indicator lamp in the instrument cluster lights up.

When emerging from a tunnel during the day, the low beams are not switched off immediately but instead only after approx. 2 minutes.

A blue sky with the sun low on the horizon can cause the lights to be switched on.





Personal responsibility

The automatic headlight control cannot serve as a substitute for your personal judgment in determining when to turn the lights on in response to ambient lighting conditions.

E. g. the sensors are unable to detect fog or hazy weather. To avoid safety risks under these conditions, you should always switch on the lights manually. ◀

Daytime running lights

With operating readiness switched on, the daytime running lights light up in position 0,  or . After operating readiness is switched off, the parking lights light up in position .

Activating/deactivating

In some countries, daytime running lights are mandatory, so it may not be possible to deactivate the daytime running lights.

On the Control Display:

1. "Settings"
2. "Lighting"
3. "Daytime running lamps"

Settings are stored for the profile currently in use.

Roadside parking lights

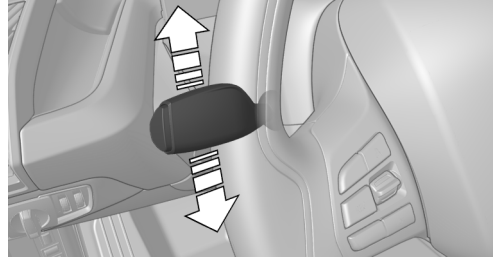

The vehicle can be illuminated on one side.

Switching on

With operating readiness switched off, press the lever either up or down past the resistance point for approx. 2 seconds.

Switch off

Briefly press the lever to the resistance point in the opposite direction.

Instrument lighting

Adjusting



The parking lights or low beams must be switched on to adjust the brightness.

Adjust the brightness with the thumbwheel.

Interior lights

General information

The interior lights, footwell lights, access lights and courtesy lights are controlled automatically.

Thumb wheel for the instrument lighting controls brightness of some of these features.

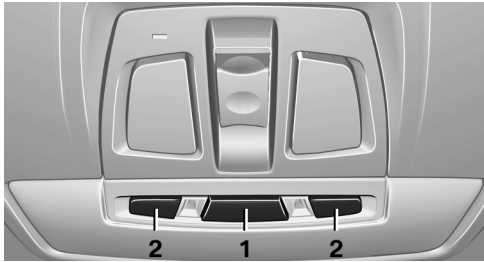

- 1 Interior lights
- 2 Reading lamp

Switching the interior lights on and off



Press button.

To reel off permanently: press the button for approx. 3 seconds.

Switch back on: press button.

Reading lights



Press button.

Reading lights are located in the front next to the interior light.

Ambient light

Depending on your optional features lighting can be adjusted for some lights in the interior.

Selecting color scheme

On the Control Display:

1. "Settings"
2. "Lighting"

3. "Ambient:"

4. Select desired setting.

To deactivate the ambient light: "Off".

With a color scheme selected and welcome lights activated they illuminate in the line's color when vehicle is unlocked.

Setting the brightness

The brightness of the ambient light can be adjusted via the thumbwheel for the instrument lighting or on the Control Display.

On the Control Display:

1. "Settings"
2. "Lighting"
3. "Brightness:"
4. Adjust the brightness.

Safety

Vehicle features and options

This chapter describes all standard, country-specific and optional features offered with the series. It also describes features that are not

necessarily available in your car, e. g., due to the selected options or country versions. This also applies to safety-related functions and systems.

Airbags

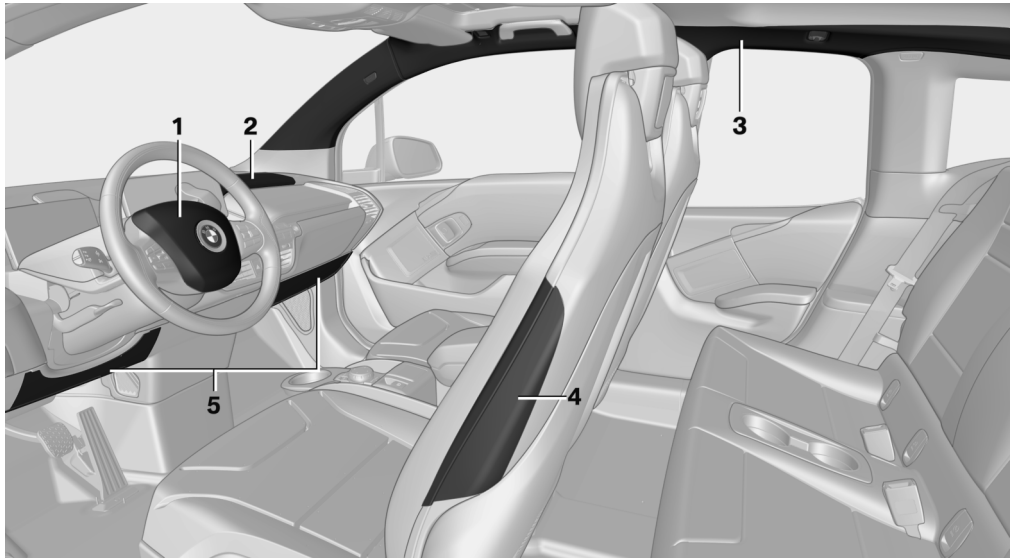

- 1 Front airbag, driver
- 2 Front airbag, front passenger
- 3 Head airbag
- 4 Side airbag
- 5 Knee airbags

Front airbags

Front airbags help protect the driver and front passenger by responding to frontal impacts in which safety belts alone would not provide adequate restraint.

Side airbags

In a lateral impact, the side airbag supports the side of the body in the chest and lap area.

Head airbags

In a lateral impact, the head airbag supports the head.

Knee airbag

The knee airbag supports the legs in a frontal impact.

Protective action

Airbags are not triggered in every impact situation, e.g., in less severe accidents or rear-end collisions.

 Information on how to ensure the optimal protective effect of the airbags

- ▶ Keep at a distance from the airbags.
- ▶ Always grasp the steering wheel on the steering wheel rim, holding your hands at the 3 o'clock and 9 o'clock positions, to keep the risk of injury to your hands or arms as low as possible when the airbag is triggered.
- ▶ There should be no person, animals, or objects between an airbag and a person.
- ▶ Do not use the cover of the front airbag on the front passenger side as a storage area.
- ▶ Dashboard and windshield on the front passenger side must stay clear - do not attach adhesive labels or coverings and do not attach brackets or cables, e. g., for GPS devices or mobile phones.
- ▶ Make sure that the front passenger is sitting correctly, i.e., keeps his or her feet and legs in the footwell; otherwise, leg injuries might occur when front airbag is activated.
- ▶ Do not place slip covers, seat cushions or other objects on the front passenger seat that are not approved specifically for seats with integrated side airbags.
- ▶ Do not hang pieces of clothing, such as jackets, over the backrests.
- ▶ Make sure that occupants keep their heads away from the side airbag and do not rest against the head airbag; otherwise, injuries might occur when airbag is activated.
- ▶ Do not remove the airbag system.
- ▶ Do not remove the steering wheel.
- ▶ Do not apply adhesive materials to the airbag cover panels, do not cover them or modify them in any way.

- ▶ Never modify either the individual components or the wiring in the airbag system. This also applies to steering wheel covers, the dashboard, the seats, the roof pillars and the sides of the roofliner. ◀

Even when you follow all instructions very closely, injury from contact with the airbags cannot be ruled out in certain situations.

The ignition and inflation noise may lead to short-term and, in most cases, temporary hearing impairment in sensitive individuals.

 Malfunction, deactivation and after-deploying the airbags

Do not touch the individual components immediately after the system has been triggered; otherwise, you may risk burns.

Only have the airbags checked, repaired or dismantled and the airbag generator scrapped by the service center or an authorized repair shop for handling explosives.

Non-professional attempts to service the system could lead to failure in an emergency or unintentional activation of the airbag - both may lead to injury. ◀

Warnings and information on the airbags are also found on the sun visors.

Functional readiness of the airbag system

 With operating readiness turned on warning light in the instrument cluster lights up briefly indicating airbag system and belt tension are functional.

Airbag system malfunctioning

- ▶ Warning lamp does not come on when operating readiness is turned on.
- ▶ The warning lamp lights up continuously.

 In case of a malfunction have airbag system checked immediately.

In case of a malfunction have airbag system checked immediately; otherwise, there is a risk

that the system does not function as expected in case of a severe accident. ◀

Automatic deactivation of the front-seat passenger airbags

The system reads if the front passenger seat is occupied by measuring the human body's resistance.

Front, knee and side airbag on the front passenger's side are either activated or deactivated.



Leave feet in the footwell

Make sure that the front passenger keeps his or her feet in the footwell; otherwise, proper functioning of the front passenger airbag might not be assured. ◀



Child restraint fixing system in the front passenger seat

Before transporting a child on the front passenger seat, refer to the safety notes and instructions for children on the front passenger seat, see Children. ◀

Malfunction of the automatic deactivation system

When transporting older children and adults, the front-seat passenger airbags may be deactivated in certain sitting positions. In this case, the indicator lamp for the front-seat passenger airbags lights up.

In this case, change the sitting position so that the front-seat passenger airbags are activated and the indicator lamp goes out.

If it is not possible to activate the airbags, have the person sit in the rear.

To enable correct recognition of the occupied seat cushion

- ▶ Do not attach covers, cushions, ball mats or other items to the front passenger seat unless they are specifically recommended by your vehicle's manufacturer.

- ▶ Do not place any electronic devices on the passenger seat if a child restraint system is to be installed on it.
- ▶ Do not place objects under the seat that could press against the seat from below.
- ▶ No moisture in or on the seat.

Indicator lamp for the front-seat passenger airbags



The indicator lamp for the front-seat passenger airbags indicates the operating state of the front-seat passenger airbags.

The lamp indicates whether the airbags are either activated or deactivated.



- ▶ The indicator lamp lights up when a child is properly seated in a child restraint fixing system or when the seat is empty. The airbags on the front passenger side are not activated.
- ▶ The indicator lamp does not light up when, e.g., a correctly seated person of sufficient size is detected on the seat. The airbags on the front passenger side are activated.

Detected child seats

The system generally detects children seated in a child seat, particularly in child seats required by NHTSA when the vehicle was manufactured. After installing a child seat, make sure that the indicator lamp for the front-seat passenger airbags lights up. This indicates

that the child seat has been detected and the front-seat passenger airbags are not activated.

Strength of the driver's and front-seat passenger airbag

The explosive power that activates driver's/front passenger's airbags very much depends on the positions of the driver's/front passenger's seat.

With a respective message appearing on Control Display calibrate the front seats to keep the accuracy of this function over the long-term.

Calibrating the front seats

A corresponding message appears on the Control Display.

1. Press the reel and move the respective seat all the way forward.
2. Press the reel forward again. The seat still moves forward slightly.
3. Readjust the seat to the desired position.

The calibration procedure is completed when the message on the Control Display disappears.

If the message continues to be displayed, repeat the calibration.

If the message does not disappear after a repeat calibration, have the system checked as soon as possible.

 Unobstructed area of movement
Ensure that the area of movement of the seats is unobstructed to avoid personal injury or damage to objects. ◀

Tire Pressure Monitor TPM

The concept

The system monitors tire inflation pressure in the four mounted tires. The system warns you if there is a significant loss of pressure in one

or more tires. For this purpose, sensors in the tire valves measure the tire inflation pressure and tire temperature.

Hints

 Tire damage due to external factors
Sudden tire damage caused by external circumstances cannot be recognized in advance. ◀

With use of the system observe further information found under Tire inflation pressure, refer to page 170.

Functional requirements

The system must have been reset with the correct tire inflation pressure; otherwise, reliable signaling of tire inflation pressure loss is not assured.

Reset the system after each adjustment of the tire inflation pressure and after every tire or wheel change.

Always use wheels with TPM electronics to ensure that the system will operate properly.

Status display

The current status of the Tire Pressure Monitor TPM can be displayed on the Control Display, e.g., whether or not the TPM is active.

1. "Vehicle info"
2. "Vehicle status"
3.  "Tire Pressure Monitor (TPM)"

The status is displayed.

Status control display

Tire and system status are indicated by the color of the wheels and a text message on the Control Display.

All wheels green

System is active and will issue a warning relative to the tire inflation pressures stored during the last reset.

One wheel is yellow

A flat tire or major drop in inflation pressure in the indicated tire.

All wheels are yellow

A flat tire or major drop in inflation pressure in several tires.

Wheels, gray

The system cannot detect a flat tire. Reasons for this may be:

- ▷ The system is being reset.
- ▷ Malfunction.

Status information

The status control display additionally shows the current tire inflation pressures and possibly tire temperatures. It shows the actual values read; they may vary depending on driving style or weather conditions.

Carry out reset

Reset the system after each adjustment of the tire inflation pressure and after every tire or wheel change.

On the Control Display and on the vehicle:

1. "Vehicle info"
2. "Vehicle status"
3.  "Perform reset"
4. Switch on drive readiness – do not drive off.
5. Reset tire inflation pressure: "Perform reset".
6. Drive away.

The tires are shown in gray and the status is displayed.

After driving faster than 19 mph/30 km/h for a short period, the set tire inflation pressures are accepted as reference values. The reset is completed automatically while driving.

The progress of the reset is displayed.

After a successfully completed Reset, the wheels on the Control Display are shown in green and "Tire Pressure Monitor (TPM) active" is displayed.

You may interrupt this trip at any time. When you continue the reset resumes automatically.

Low tire pressure message



The yellow warning lamp lights up. A Check Control message is displayed.

- ▷ There is a flat tire or a major loss in tire inflation pressure.
 - ▷ No reset was performed for the system. The system therefore issues a warning based on the tire inflation pressures before the last reset.
1. Reduce your speed and stop cautiously. Avoid sudden braking and steering maneuvers.
 2. Identify the damaged wheel. Do so by checking the tire inflation pressure using the Mobility System. To correct the tire inflation pressure, refer to page 177.
 3. Repair flat tire with the Mobility System, refer to page 174, or replace the damaged wheel.

If a Mobility System is not available, contact the service center.

A low tire inflation pressure might turn on DSC Dynamic Stability Control.

Required tire inflation pressure check message

A Check Control message is displayed in the following situations

- ▷ The system has detected a wheel change, but no reset was done.
- ▷ Inflation was not carried out according to specifications.
- ▷ The tire inflation pressure has fallen below the level of the last confirmation.

In this case:

- ▶ Check the tire pressure and correct as needed.
- ▶ Carry out a reset of the system after a tire change.

System limits

The system does not function properly if a reset has not been carried out, e.g., a flat tire is reported though tire inflation pressures are correct.

The tire inflation pressure depends on the tire's temperature. Driving or exposure to the sun will increase the tire's temperature, thus increasing the tire inflation pressure. The tire inflation pressure is reduced when the tire temperature falls again. These circumstances may cause a warning when temperatures fall very sharply.

Malfunction



The yellow warning lamp flashes and then lights up continuously. A Check Control message is displayed. No flat tire or loss of tire inflation pressure can be detected.

Display in the following situations:

- ▶ A wheel without TPM electronics is fitted: have the service center check it if needed.
- ▶ Malfunction: have the system checked by your service center.
- ▶ TPM was unable to complete the reset. Reset the system again.
- ▶ Interference through systems or devices with the same radio frequency: after leaving the area of the interference, the system automatically becomes active again.

Declaration according to NHTSA/ FMVSS 138 Tire Pressure Monitoring System

Each tire, including the spare (if provided) should be checked monthly when cold and inflated to the inflation pressure recommended

by the vehicle manufacturer on the vehicle placard or tire inflation pressure label. (If your vehicle has tires of a different size than the size indicated on the vehicle placard or tire inflation pressure label, you should determine the proper tire inflation pressure for those tires.) As an added safety feature, your vehicle has been equipped with a tire pressure monitoring system (TPMS) that illuminates a low tire pressure telltale when one or more of your tires is significantly under-inflated. Accordingly, when the low tire pressure telltale illuminates, you should stop and check your tires as soon as possible, and inflate them to the proper pressure. Driving on a significantly under-inflated tire causes the tire to overheat and can lead to tire failure. Under-inflation also reduces fuel efficiency and tire tread life, and may affect the vehicle's handling and stopping ability. Please note that the TPMS is not a substitute for proper tire maintenance, and it is the driver's responsibility to maintain correct tire pressure, even if under-inflation has not reached the level to trigger illumination of the TPMS low tire pressure telltale. Your vehicle has also been equipped with a TPMS malfunction indicator to indicate when the system is not operating properly. The TPMS malfunction indicator is combined with the low tire pressure telltale. When the system detects a malfunction, the telltale will flash for approximately one minute and then remain continuously illuminated. This sequence will continue upon subsequent vehicle start-ups as long as the malfunction exists. When the malfunction indicator is illuminated, the system may not be able to detect or signal low tire pressure as intended. TPMS malfunctions may occur for a variety of reasons, including the installation of replacement or alternate tires or wheels on the vehicle that prevent the TPMS from functioning properly. Always check the TPMS malfunction telltale after replacing one or more tires or wheels on your vehicle to ensure that the replacement or alternate tires and wheels allow the TPMS to continue to function properly.

FTM Flat Tire Monitor

The concept

The system detects tire inflation pressure loss on the basis of rotation speed differences between the individual wheels while driving.

In the event of a tire inflation pressure loss, the diameter and therefore the rotational speed of the corresponding wheel changes. This will be detected and reported as a flat tire.

The system does not measure the actual inflation pressure in the tires.

Functional requirements

The system must have been initialized when the tire inflation pressure was correct; otherwise, reliable flagging of a flat tire is not assured. Initialize the system after each correction of the tire inflation pressure and after every tire or wheel change.

Status display

The current status of the Flat Tire Monitor can be displayed on the Control Display, e.g., whether or not the FTM is active.

On the Control Display:

1. "Vehicle info"
2. "Vehicle status"
3.  "Flat Tire Monitor (FTM)"

The status is displayed.

Initialization

When initializing the once set inflation tire pressures serve as reference values in order to detect a flat tire. Initialization is started by confirming the tire inflation pressures.

Do not initialize the system when driving with snow chains.

On the Control Display:

1. "Vehicle info"
2. "Vehicle status"

3.  "Perform reset"
4. Switch on drive readiness – do not drive off.
5. Start the initialization with "Perform reset".
6. Drive away.

The initialization is completed while driving, which can be interrupted at any time.

The initialization automatically continues when driving resumes.

Indication of a flat tire



The yellow warning lamp lights up. A Check Control message is displayed.

There is a flat tire or a major loss in tire inflation pressure.

1. Reduce your speed and stop cautiously. Avoid sudden braking and steering maneuvers.
2. Identify the damaged wheel. Do so by checking the tire inflation pressure using the Mobility System. If the tire inflation pressure in all tires is correct, the Flat Tire Monitor may not have been initialized. In this case, initialize the system.
3. Repair flat tire with the Mobility System, refer to page 174, or replace the damaged wheel.

If a Mobility System is not available, contact the service center.

When a flat tire is indicated, DSC Dynamic Stability Control is switched on if needed.

System limits



Sudden tire damage

Sudden serious tire damage caused by external circumstances cannot be recognized in advance. ◀

A natural, even tire inflation pressure loss in all four tires will not be recognized. Therefore, check the tire inflation pressure regularly.

The system could be delayed or malfunction in the following situations:

- ▷ When the system has not been initialized.
- ▷ When driving on a snowy or slippery road surface.
- ▷ Sporty driving style: spinning traction wheels, high lateral acceleration (drifting).
- ▷ When driving with snow chains.

Intelligent Safety

The concept

Intelligent Safety enables central operation of the driver assistance system.

The intelligent safety systems can help prevent an imminent collision.

- ▷ Front-end collision warning with City Braking function, refer to page 100.
- ▷ Pedestrian warning with City Braking function, refer to page 102.

Note



Personal responsibility

The system does not serve as a substitute for the driver's personal judgment of the traffic situation.

Be aware of the traffic situation and the vehicle's surroundings at all times, otherwise accidents are still possible despite all warnings. ◀

At a glance

Button in the vehicle



Intelligent Safety button

Switching on/off

Some Intelligent Safety systems are automatically active after every departure. Some Intelligent Safety systems activate according to the last setting.



Press button briefly:

- ▷ The menu for the intelligent safety system is displayed. The systems are individually switched off according to their respective settings.
- ▷ LED lights up orange or goes out respectively to their individual settings.

Adjust as needed. Individual settings are stored for the profile currently in use.



Press button again:

- ▷ All Intelligent Safety systems are activated.
- ▷ The LED lights up green.



Hold down button:

- ▷ All Intelligent Safety systems are turned off.
- ▷ The LED goes out.

Front-end collision warning with City Braking function

The concept

The system can help prevent accidents. If an accident cannot be prevented, the system will help reduce the collision speed.

The system sounds a warning before an imminent collision and actuates brakes independently if needed.

The automatic braking intervention is done with limited force and duration.

A camera in the area of the rearview mirror controls the system.

The front-end collision warning is available even if cruise control has been deactivated.

With the vehicle approaching another vehicle intentionally the collision warning is delayed avoiding false alarm.

Note



Personal responsibility

The system does not serve as a substitute for the driver's personal judgment of the traffic situation.

Be aware of the traffic situation and the vehicle's surroundings at all times, otherwise accidents are still possible despite all warnings. ◀

General information

The system warns at two levels of an imminent danger of collision at speeds from approx. 3 mph/5 km/h. Time of warnings may vary with the current driving situation.

Appropriate braking kicks in at speeds of up to 35 mph/60 km/h.

Detection range

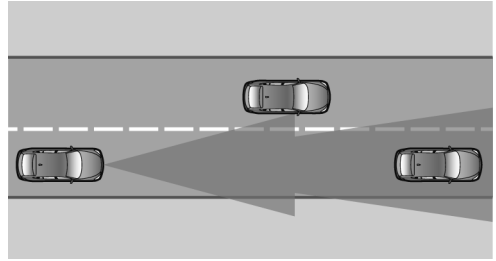

It responds to objects if they are detected by the system.

At a glance

Button in the vehicle



 Intelligent Safety button

Camera

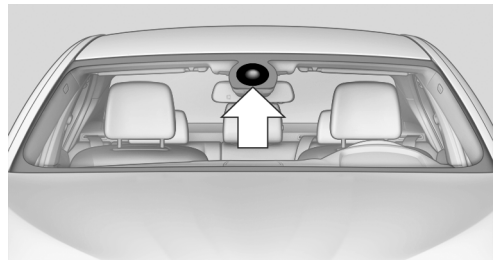

The camera is found near the interior rearview mirror.

Keep the windshield in the area behind the interior rearview mirror clean and clear.

Switching on/off

Switching on automatically

The system is automatically active after every driving-off.

Switching on/off manually



Press button briefly:

- ▶ The menu for the intelligent safety system is displayed. The systems are individually switched off according to their respective settings.
- ▶ LED lights up orange or goes out respective to their individual settings.

Adjust as needed. Individual settings are stored for the profile currently in use.



Press button again:

- ▶ All Intelligent Safety systems are activated.
- ▶ The LED lights up green.



Hold down button:

- ▶ All Intelligent Safety systems are turned off.
- ▶ The LED goes out.

Setting the warning time

The warning time can be set via iDrive.

1. "Settings"
2. "Frontal Coll. Warning"
3. Activate the desired time on the Control Display.

The selected time is stored for the profile currently in use.

Warning with braking function

Note



Adapting your speed and driving style
The warning does not relieve the driver of the responsibility to adapt his or her driving speed and style to the traffic conditions. ◀

Display

If a collision with a vehicle detected in this way is imminent, a warning symbol appears on the instrument cluster.

Symbol	Measure
	The vehicle lights up red: prewarning. Brake and increase distance.
	The vehicle flashes red and an acoustic signal sounds: acute warning. You are requested to intervene by braking or make an evasive maneuver.



Prewarning

This warning is issued, e.g., when there is the impending danger of a collision or the distance to the vehicle ahead is too small.

The driver must intervene actively when there is a prewarning.

Acute warning with braking function

Warning of the imminent danger of a collision when the vehicle approaches another object at a relatively high differential speed.

The driver must intervene actively when there is an acute warning. If necessary, the driver is assisted by a minor automatic braking intervention in a possible risk of collision.

Acute warnings can also be triggered without previous prewarning.

Braking intervention

The warning prompts the driver himself/herself to react. During a warning, the maximum braking force is used. Premise for the brake booster is sufficiently quick and hard stepping on the brake pedal. The system can assist with some braking intervention if there is risk of a collision. At low speeds vehicles may thus come to a complete stop.

The braking intervention is executed only if DSC Dynamic Stability Control is switched on.

The braking intervention can be interrupted by stepping on the accelerator pedal or by actively moving the steering wheel.

Object detection can be restricted. Limitations of the detection range and functional restrictions are to be considered.



Tow-starting and towing

For towing the vehicle turn, switch off the Intelligent Safety systems; otherwise malfunctions of the individual braking systems might lead to accidents. ◀

System limits



Be alert

Due to system limitations, warnings may be not issued at all, or may be issued late or improperly. Therefore, always be alert and ready to intervene; otherwise, there is the risk of an accident. ◀

Detection range

The system's detection potential is limited.

Thus a warning might not be issued or be issued late.

E. g. the following situations may not be detected:

- ▷ Slow moving vehicles when you approach them at high speed.
- ▷ Vehicles that suddenly swerve in front of you, or sharply decelerating vehicles.

- ▷ Vehicles with an unusual rear appearance.
- ▷ Two-wheeled vehicles ahead of you.

Functional limitations

The system may not be fully functional in the following situations:

- ▷ In heavy fog, rain, sprayed water or snow-fall.
- ▷ In tight curves.
- ▷ If the driving stability control systems are deactivated, e.g. DSC OFF.
- ▷ If the field of view of the camera in the mirror is dirty or obscured.
- ▷ Up to 10 seconds after drive readiness is established.
- ▷ During calibration of the camera immediately after vehicle shipment.
- ▷ If there is constant blinding effects because of oncoming light, e.g., from the sun low in the sky.

Warning sensitivity

The more sensitive the warning settings are, the more warnings are displayed. However, there may also be an excess of false warnings.

Pedestrian warning with city braking function

The concept

The system can help prevent accidents with pedestrians.

The system issues a warning in the city driving speed area if there is imminent danger of a collision with pedestrians and includes a braking function.

The camera in the area of the rearview mirror controls the system.

Note



Personal responsibility

The system does not serve as a substitute for the driver's personal judgment of the traffic situation.

Be aware of the traffic situation and the vehicle's surroundings at all times, otherwise accidents are still possible despite all warnings. ◀

General information

In daylight the system warns of possible collisions with pedestrians at speeds from about 6 mph/10 km/h to about 35 mph/60 km/h shortly before a collision the system supports you with a braking intervention.

Under those circumstances it reacts to people who are within the detection range of the system.

Detection range

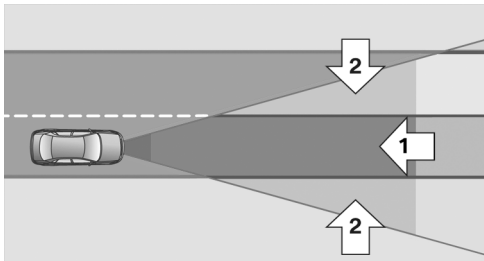

The detection area in front of the vehicle is divided into two areas.

- ▶ Central area, arrow 1, directly in front of the vehicle.
- ▶ Expanded area, arrow 2, to the right and left.

A collision is imminent if pedestrians are located within the central area. A warning is issued about pedestrians who are located within the extended area only if they are moving in the direction of the central area.

At a glance

Button in the vehicle



Intelligent Safety button

Camera

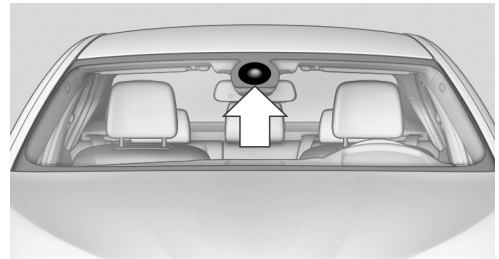

The camera is found near the interior rearview mirror.

Keep the windshield in the area behind the interior rearview mirror clean and clear.

Switching on/off

Switching on automatically

The system is automatically active after every driving-off.

Switching on/off manually



Press button briefly:

- ▶ The menu for the intelligent safety system is displayed. The systems are individually switched off according to their respective settings.

- ▶ LED lights up orange or goes out respective to their individual settings.

Adjust as needed. Individual settings are stored for the profile currently in use.



Press button again:

- ▶ All Intelligent Safety systems are activated.
- ▶ The LED lights up green.



Hold down button:

- ▶ All Intelligent Safety systems are turned off.
- ▶ The LED goes out.

Warning with braking function

Note



Adapting your speed and driving style

The warning does not relieve the driver of the responsibility to adapt his or her driving speed and style to the traffic conditions. ◀

Display

If a collision with a person detected in this way is imminent, a warning symbol appears on the instrument cluster.



The red symbol is displayed and a signal sounds.

Intervene immediately by braking or make an evasive maneuver.

Braking intervention

The warning prompts the driver himself/herself to react. During a warning, the maximum braking force is used. Premise for the brake booster is sufficiently quick and hard stepping on the brake pedal. The system can assist with some braking intervention if there is risk of a collision. At low speeds vehicles may thus come to a complete stop.

The braking intervention is executed only if DSC Dynamic Stability Control is switched on.

The braking intervention can be interrupted by stepping on the accelerator pedal or by actively moving the steering wheel.

Object detection can be restricted. Limitations of the detection range and functional restrictions are to be considered.



Tow-starting and towing

For towing the vehicle turn, switch off the Intelligent Safety systems; otherwise malfunctions of the individual braking systems might lead to accidents. ◀

System limits



Be alert

Due to system limitations, warnings may be not issued at all, or may be issued late or improperly. Therefore, always be alert and ready to intervene; otherwise, there is the risk of an accident. ◀

Detection range

The detection potential of the camera is limited.

Thus a warning might not be issued or be issued late.

E. g. the following situations may not be detected:

- ▶ Partially covered pedestrians.
- ▶ Pedestrians that are not detected as such because of the viewing angle or contour.
- ▶ Pedestrians outside of the detection range.
- ▶ Pedestrians having a body size less than 32 in/80 cm.

Functional limitations

The system may not be fully functional or may not be available in the following situations:

- ▶ In heavy fog, rain, sprayed water or snow-fall.

- ▷ In tight curves.
- ▷ If the driving stability control systems are deactivated, e.g. DSC OFF.
- ▷ If the camera viewing field or the front windshield are dirty or covered.
- ▷ Up to 10 seconds after drive readiness is established.
- ▷ During calibration of the camera immediately after vehicle shipment.
- ▷ If there is constant blinding effects because of oncoming light, e.g., from the sun low in the sky.
- ▷ When it is dark outside.

Driving stability control systems

Vehicle features and options

This chapter describes all standard, country-specific and optional features offered with the series. It also describes features that are not necessarily available in your car, e. g., due to the selected options or country versions. This also applies to safety-related functions and systems.

Antilock Brake System ABS

ABS prevents locking of the wheels during braking.

The vehicle contains its steering power even during full brake applications, thus increasing active safety.

ABS is ready when car is ready to drive.

Brake assistant

When you apply the brakes rapidly, this system automatically produces the greatest possible braking force boost. It reduces the braking distance to a minimum during emergency stop. This system utilizes all of the benefits provided by ABS.

Do not reduce the pressure on the brake pedal for the duration of the emergency stop.

Energy recovery

In the event of danger, such as with locked wheels, energy recovery is reduced in order to prevent unstable driving situations.



Always be ready to apply the brake

Always be ready to apply the brake, because without energy recovery there is also no braking action through the electric drive unit.

The vehicle could roll further than anticipated. This may constitute a danger for other traffic. ◀

DSC Dynamic Stability Control

The concept

DSC prevents traction loss in the power wheels when driving off and accelerating.

DSC also recognizes unstable vehicle conditions such as fishtailing or nose-diving. Within the physical limits DSC helps to keep the vehicle on a steady course by reducing engine speed and by applying brakes to the individual wheels.

Note



Adjust your driving style to the situation

An appropriate driving style is always the responsibility of the driver.

The laws of physics cannot be repealed, not even with DSC.

Therefore, do not reduce the additional safety margin by driving in a risky manner. ◀



Do not deactivate DSC when driving with roof load

Do not deactivate Dynamic Stability Control DSC when driving with roof load, e.g. roof-mounted luggage rack.

Otherwise, driving safety is not given in driving-critical situation due to the elevated center of gravity. ◀

Indicator/warning lights



The indicator lamp flashes: DSC controls the drive and braking forces.

The indicator lamp lights up: DSC has failed.

DTC Dynamic Traction Control

The concept

The DTC system is a version of the DSC where forward momentum is optimized.

The system ensures maximum headway on special road conditions or loose road surfaces, e.g., unplowed snowy roads, but with somewhat limited driving stability.

Activating the Dynamic Traction Control DTC provides maximum traction. Driving stability is limited during acceleration and when driving in curves.

Therefore drive with appropriate caution.

You may find it useful to briefly activate DTC under the following special circumstances:

- ▶ When driving in slush or on uncleared, snow-covered roads.
- ▶ When freeing vehicle from deep snow or driving off from loose grounds.
- ▶ When driving with snow chains.

Deactivating/activating DTC Dynamic Traction Control

Activating DTC

1. "Settings"
2. "Traction control"
3. "TRACTION"

TRACTION and the DSC OFF indicator lamp lights up.

Deactivating DTC

1. "Settings"
2. "Traction control"
3. "Normal"

TRACTION and the DSC OFF indicator lamp go out.

When drive readiness is switched on, DTC is automatically deactivated.

Driving Dynamics Control

The concept

The Driving Dynamics Control helps to fine-tune the vehicle's settings and features. Various programs can be selected for this purpose.

At a glance

Button in the vehicle



Operating the programs

Driving Dynamics Control	Program
	COMFORT
	ECO PRO
	ECO PRO+

COMFORT

For balanced tuning.

Activating COMFORT



Press button repeatedly until COMFORT is displayed in the instrument cluster.

ECO PRO

ECO PRO, refer to page 151, provides consistent tuning to maximize range.

Comfort functions and the engine controller are adjusted.

The program can be configured to individual specifications.

Activating ECO PRO



Press button repeatedly until ECO PRO is displayed in the instrument cluster.

Configuring ECO PRO

1. Activate ECO PRO.
2. "Configure ECO PRO"

Make the desired settings.

ECO PRO+

ECO PRO+, refer to page 151, also limits the maximum speed and reduces climate control and lighting functions.

Comfort functions and the engine controller are adjusted.

Activating ECO PRO+



Press button repeatedly until ECO PRO+ is displayed in the instrument cluster.

Displays

Program selection

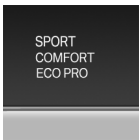

Pressing the button displays a list of the selectable programs. Depending on your vehicle's optional features, the list in the instrument cluster can differ from the illustration shown.

the illustration shown.

Selected program

The ECO PRO and ECO PRO+ driving programs are shown in the instrument cluster. In addition, the display on the automatic climate control lights up

Display on the Control Display

Program changes can be displayed on the Control Display.

1. "Settings"
2. "Driving mode"
3. "Driving mode info"

Drive-off assistant

This system supports driving off on inclines. The parking brake is not required.

1. Hold the vehicle in place with the foot brake.
2. Release the foot brake and drive off without delay.

After the foot brake is released, the vehicle is held in place for approx. 2 seconds.

Depending on the vehicle load, the vehicle may roll back slightly.



Driving off without delay

After releasing the foot brake, start driving without delay, since the drive-off assistant will not hold the vehicle in place for more than approx. 2 seconds and the vehicle will begin to roll back. ◀

Driving comfort

Vehicle features and options

This chapter describes all standard, country-specific and optional features offered with the series. It also describes features that are not necessarily available in your car, e. g., due to the selected options or country versions. This also applies to safety-related functions and systems.

Camera-based cruise control with Stop & Go function, ACC

The concept

Use this system to select a desired speed that the vehicle will maintain automatically on clear roads.

To the extent possible, the system automatically adjusts the speed to a slower vehicle ahead of you.

A camera on the interior rear view mirror is used to detect vehicles driving ahead.

The distance that the vehicle maintains to the vehicle ahead of you can be varied.

For safety reasons, it depends on the speed.

To maintain a certain distance, the system automatically reduces the speed, applies the brakes lightly, or accelerates again if the vehicle ahead begins moving faster.

If the vehicle ahead of you brakes to a halt, and then proceeds to drive again within a brief period, the system is able to detect this within the given system limits. Your own vehicle will brake automatically and then accelerate again.

If the vehicle ahead of you drives away again after a prolonged period, briefly press the accelerator pedal or press the appropriate button to reactivate the system. The vehicle will automatically accelerate.

As soon as the road is clear, the vehicle accelerates to the desired speed.

The speed is also maintained downhill, but may not be maintained uphill if engine power is insufficient.

General information

Depending on the driving settings, the features of the cruise control can change in certain areas.

Hints



Personal responsibility

Even an active system holds the driver responsible for his or her driving, particularly for staying in your lane, adjusting your speed, keeping your distance and for your driving style all in relation to traffic.

Technically the system has its limits, it cannot independently react to all traffic situations.

Monitor your driving, be on the alert, observe the vehicle surroundings and other traffic and react when needed, e.g. through braking, steering or make evasive maneuvers - risk of accident. ◀



Unfavorable weather conditions





In the event of unfavorable weather and light conditions, e. g. if there is rain, snowfall, slush, fog or glare, this may result in poorer recognition of vehicles as well as short-term interruptions for vehicles that are already detected. Drive attentively, and react to the current traffic situation. Intervene actively when necessary, e.g., by braking, steering or making an evasive maneuver, otherwise, there is the risk of an accident. ◀

 Before leaving the vehicle, secure it against moving on its own.

Before leaving the vehicle, set the parking brake and reel off drive readiness. Otherwise, the vehicle may begin to move. ◀

At a glance

Buttons on the steering wheel

Press button	Function
	Cruise control on/off, interrupting, refer to page 110.
	Store/maintain speed, refer to page 111.
	Resume speed, refer to page 112.
	Adjust distance, refer to page 112.
	Rocker reel: Maintain, store, change speed, refer to page 111.

Buttons are arranged according to vehicle's series, optional features and country specifications.

Camera

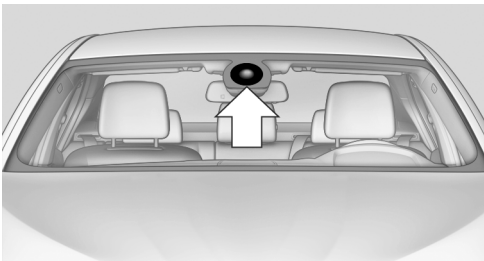

The camera is found near the interior rearview mirror.

Keep the windshield in the area behind the interior rearview mirror clean and clear.

A dirty or covered area in front of the interior mirror may hinder the detection of vehicles.

If necessary, clean the area in front of the interior mirror, e.g., carefully remove salt residue in the winter.

Switching on/off and interrupting cruise control

Switching on

 Press button on the steering wheel.

 The indicator lamp in the instrument cluster lights up.

 Desired speed becomes current speed and will be displayed - beside the symbol - in the Info Display.

Cruise control can be used.

Switch off

 Deactivated or interrupted system
With deactivated or interrupted system use your brakes, steering and moves as usual to avoid the chance of an accident. ◀

To switch off the system while standing, step on brake pedal at the same time.

 Press button on the steering wheel.

- ▷ If active: press twice.
- ▷ If interrupted: press once.

The displays go out. The stored desired speed and distance are deleted.

Interrupting

 Press button on the steering wheel.

If interrupting the system while stationary, press on the brake pedal at the same time.

The system is automatically interrupted in the following situations:

- ▷ When the brakes are applied.
- ▷ When selector lever position D is disengaged.
- ▷ When Dynamic Traction Control DTC is activated.
- ▷ When DSC is actively controlling stability.
- ▷ If the safety belt and the driver's door are opened while the vehicle is standing still.
- ▷ If the detection range of the camera is impaired, e.g., by soiling, heavy precipitation or glare effects from the sun.

Maintaining, storing, and changing the speed

Hints

 Adjusting the desired speed
Modify desired speed to road conditions and be ready to brake at all times; otherwise, there is the risk of an accident. ◀

 Differences in speed
Large differences in speed relative to other vehicles cannot be compensated by the system such as in the following situations:

- ▷ When fast approaching a slowly moving vehicle.
- ▷ When another vehicle suddenly swerves into the wrong lane.
- ▷ When stationary objects are approached at high speed. ◀

Maintaining/storing the speed

 Press button.
Or:

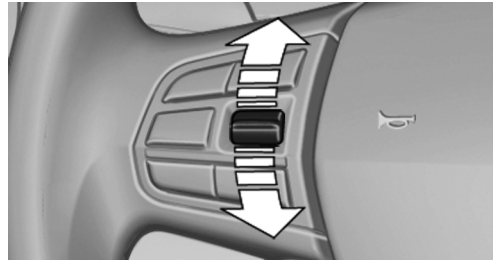

Press the rocker reel while the system is interrupted.

When the system is switched on, the current speed is maintained and stored as the desired speed.

This is displayed in the speedometer and continuously in the instrument cluster. Displays in the instrument cluster, refer to page 112.

When cruise control is maintained or stored, DSC Dynamic Stability Control will be turned on if needed.

Changing the speed

Press the rocker reel up or down repeatedly until the desired speed is set.

If active, the displayed speed is stored and the vehicle reaches the stored speed when the road is clear.

- ▷ Each time the rocker reel is pressed to the point of resistance, the desired speed increases or decreases by approx. 1 mph/1 km/h.
- ▷ Each time the rocker reel is pressed past the point of resistance, the desired speed increases or decreases by a maximum of 5 mph/10 km/h.

Hold the rocker reel in position to repeat the action.

Distance



Select a distance

Adjust the distance according to the traffic and weather conditions; otherwise, there is the risk of an accident. Maintain the prescribed safety distance. ◀

Adjust distance



Press button repeatedly until the desired distance is set.



The set distance is briefly displayed in the left part of the instrument cluster.

Calling up the desired speed and distance

While driving



Press button with the system switched on.

Desired speed and distance are then continued with these settings. The instrument cluster briefly displays the selected distance.

In the following cases, the stored speed value is deleted and cannot be called up again:

- ▷ When the system is switched off.
- ▷ When drive readiness is switched off.

While standing

The system brought the vehicle to a complete standstill:



- ▷ Green indicator in the info display:

Your vehicle accelerates automatically as soon as the vehicle in the camera's range moves off.



- ▷ Indicator in the info display switches to orange: no automatic driving off.

To accelerate to the desired speed automatically, briefly press the accelerator or press the RES or SET button.

Flashing bar in the distance display indicates that the vehicle in the camera detection range has moved away.

Your vehicle was brought down to a halt through stepping on the brake pedal and it is standing behind another vehicle:

1.  Press button to call up a stored desired speed.
2. Release the brake pedal.
3. Step on the accelerator briefly, or press the RES rocker reel when the vehicle ahead of you drives away.

Changing between cruise control with/without distance control



Traffic ahead

The cruise control does not react to traffic driving ahead of you, but instead maintains the stored speed. Take this factor into account – you yourself must react; otherwise, there is the risk of an accident. ◀

To reel over to cruise control:



Press and hold this button.



The indicator lamp in the instrument cluster comes on and check-control message is displayed as soon as the reel is made to cruise control.

In order to reel back to Active Cruise Control, press the button again briefly.

Displays in the instrument cluster

Desired speed



The desired speed is displayed next to the symbol in the info display.

- ▶ The indicator lights up green: the system is active.
- ▶ The indicator lights up orange: the system has been interrupted.
- ▶ No display: system is switched off.

Status display



Selected desired speed.

If --- appears briefly on the display for Check Control messages, it is possible that the system requirements are currently not ready for operations.

Distance to vehicle ahead of you

Selected distance from the vehicle driving ahead is briefly displayed in the left hand portion of the instrument cluster.

Distance display



Distance 1



Distance 2



Distance 3



Distance 4

This value is set after the system is switched on.

Indicator/warning lights



Personal responsibility

The indicator and warning lights do not relieve the driver of the responsibility to adapt his or her desired driving speed and style to the traffic conditions. ◀



The vehicle symbol lights up orange:

A vehicle has been detected ahead of you.



The vehicle symbol flashes orange:
The conditions are not adequate for the system to work.

The system was deactivated but applies the brakes until you actively resume control by pressing on the brake pedal or accelerator pedal.



The vehicle symbol flashes red and an acoustic signal sounds:

You are requested to intervene by braking or make an evasive maneuver.



The system has been interrupted or distance control is deactivated because the accelerator pedal is being pressed; a vehicle was not detected.



Distance control is deactivated because the accelerator pedal is being pressed; a vehicle was detected.



Flashing bar: the detected vehicle has driven away.

ACC is no longer accelerating. To accelerate further, activate ACC by stepping on the accelerator pedal, pressing the RES button or rocker reel.

Changing between cruise control with/without distance control

Display in the instrument cluster:



Cruise Control without distance control.



Active Cruise Control with distance control.

System limits

Speed range

The system is best used on well-constructed roads.

The desired speed can be set between 20 mph/30 km/h and 85 mph/140 km/h.

The system can also be activated when stationary.

Comply with the legal speed limit in every situation when using the system.

Detection range

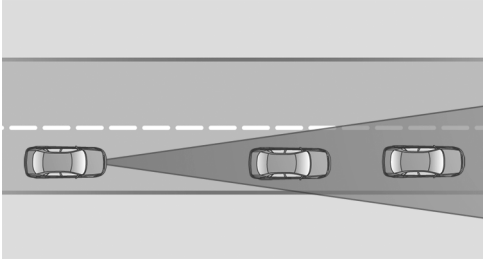

The detection capability of the system and the automatic braking capability are limited.

Two-wheeled vehicles for instance might not be detected.

⚠ Limited detection potential

Because of the limited possible detection, you should be alert at all times so that you can intervene if needed; otherwise, there is the risk of an accident. ◀

Deceleration

The system does not decelerate for:

- ▷ Pedestrians, cyclists or similar slow road users.
- ▷ Red traffic lights.
- ▷ Cross traffic.
- ▷ Oncoming traffic.
- ▷ Unlit vehicles or vehicles with defective lighting at night.

Swerving vehicles

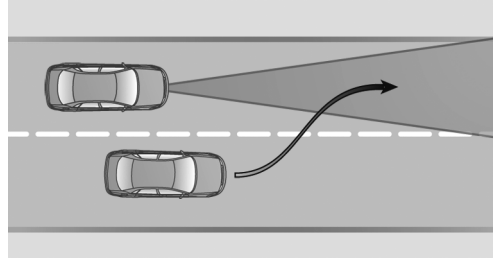

A vehicle driving in front of you is not detected until it is completely within the same lane as your vehicle.

⚠ Swerving vehicles

If a vehicle driving ahead of you suddenly swerves into your lane, the system may not be able to automatically restore the selected distance. This also applies to major speed differences to vehicles driving ahead of you, e.g., when rapidly approaching a truck. When a vehicle driving ahead of you is reliably detected, the system requests that the driver intervene by braking and carrying out evasive maneuvers, if needed. You must react yourself; otherwise, there is the risk of an accident. ◀

Cornering

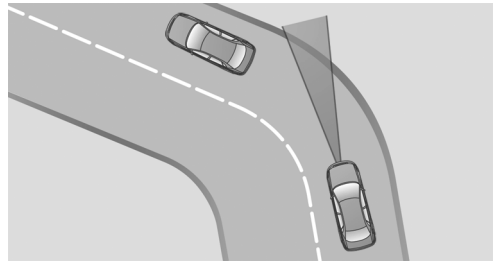

If the desired speed is too high for a curve, the speed is reduced slightly, although curves cannot be anticipated in advance. Therefore, drive into a curve at an appropriate speed.

In tight curves the system offers only restricted detection where a vehicle ahead of you might be detected late or not at all.

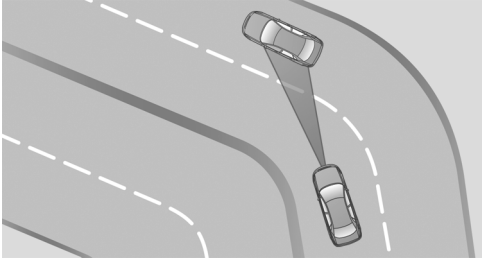

When you approach a curve the system may briefly report vehicles in the next lane due to the bend of the curve. If the system decelerates you may compensate it by briefly accelerating.

After releasing the gas pedal the system is re-activated and controls speed independently.

Driving away

In some situations, the vehicle cannot drive off automatically; for example:

- ▷ On steep inclines.
- ▷ From behind bumps in the road.

In these cases, step on the accelerator pedal.

Malfunction

A Check Control message is displayed if the system fails.

The system may not be fully functional in the following situations:

- ▷ When an object was not correctly detected.
- ▷ In heavy fog, rain, sprayed water or snowfall.
- ▷ In tight curves.
- ▷ If the camera viewing field or the front windshield are dirty or covered.
- ▷ When driving toward bright lights.
- ▷ Up to 20 seconds after drive readiness is switched on via the Start/Stop knob.
- ▷ During calibration of the camera immediately after vehicle shipment.

Cruise control

The concept

The system maintains a preset speed via the buttons on the steering wheel. The system brakes on downhill gradients if engine braking is insufficient.

General information

Depending on the driving settings, the features of the cruise control can change in certain areas.

Hints



Unfavorable conditions





Do not use the system if unfavorable conditions make it impossible to drive at a constant speed, e.g.:

- ▷ On winding roads.
- ▷ In heavy traffic.
- ▷ On slippery roads, in fog, snow or rain, or on a loose road surface.

Otherwise, you could lose control of the vehicle and cause an accident.◀

At a glance

Buttons on the steering wheel

Press button	Function
	System on/off, interrupt
	Store speed
	Resume speed
	Rocker reel: change, hold, store speed

Controls

Switching on



Press button on the steering wheel.



The indicator lamp in the instrument cluster lights up.



Desired speed becomes current speed and will be displayed - beside the symbol - in the Info Display.

Cruise control can be used.

Switch off



Deactivated or interrupted system

With deactivated or interrupted system use your brakes, steering and moves as usual to avoid the chance of an accident. ◀



Press button.

- ▷ If active: press twice.
- ▷ If interrupted: press once.

The displays go out. The stored desired speed is deleted.

Interrupting



When active, press the button.

The system is automatically interrupted if:

- ▷ The brakes are applied.
- ▷ Selector lever position D is disengaged.
- ▷ DTC Dynamic Traction Control is activated.
- ▷ DSC is actively controlling stability.

Maintaining, storing, and changing the speed

Hints



Adjusting the desired speed

Modify desired speed to road conditions and be ready to brake at all times; otherwise, there is the risk of an accident. ◀

Maintaining/storing the speed



Press button.

Or:

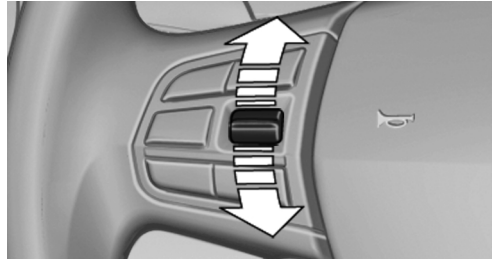

Press the rocker reel while the system is interrupted.

When the system is switched on, the current speed is maintained and stored as the desired speed.

This is displayed in the instrument cluster.

When cruise control is maintained or stored, DSC Dynamic Stability Control will be turned on if needed.

Changing the speed

Press the rocker reel up or down repeatedly until the desired speed is set.

If active, the displayed speed is stored and the vehicle reaches the stored speed when the road is clear.

- ▷ Each time the rocker reel is pressed to the point of resistance, the desired speed increases or decreases by approx. 1 mph/1 km/h.

- ▷ Each time the rocker reel is pressed past the point of resistance, the desired speed increases or decreases by a maximum of 5 mph/10 km/h.

The maximum speed that can be set depends on the vehicle.

- ▷ Pressing the rocker reel to the resistance point and holding it accelerates or decelerates the vehicle without requiring pressure on the accelerator pedal.

After the rocker reel is released, the vehicle maintains its final speed. Pressing the reel beyond the resistance point causes the vehicle to accelerate more rapidly.

Resuming the desired speed



Press button.

The stored speed is reached and maintained.

Displays in the instrument cluster

Indicator lamp



Depending on how the vehicle is equipped, the indicator lamp in the instrument cluster indicates whether the system is switched on.

Desired speed



The desired speed is displayed next to the symbol in the info display.

- ▷ The indicator lights up green: the system is active.
- ▷ The indicator lights up orange: the system has been interrupted.
- ▷ No display: system is switched off.

Status display



Selected desired speed.

If --- appears briefly on the display for Check Control messages, it is possible that the system requirements are currently not ready for operations.

PDC Park Distance Control

The concept

PDC is a support when parking. When you slowly approach an object in the rear - or also in the front of the vehicle if the feature is available - then the object is reported through:

- ▷ Signal tones.
- ▷ Visual display.

General information

Ultrasound sensors in the bumpers measure the distances from objects.

The maneuvering range, depending on the obstacle and environmental conditions, is approx. 6 ft/2 m.

An acoustic warning is first given:

- ▷ By the front sensors and the two rear corner sensors at approx. 24 in/60 cm.
- ▷ By the rear middle sensors at approx. 5 ft/1.50 m.

To ensure full functionality:

- ▷ Do not cover sensors, e.g., with stickers, bicycle racks and the like.
- ▷ Keep the sensors clean and free of ice.
- ▷ When using high-pressure washers, do not spray the sensors for long periods and maintain a distance of at least 12 in/30 cm.

Hints



Personal responsibility

Even an active system does not relieve the driver from personal responsibility while driving.

Technically the system has its limits, it cannot independently react to all traffic situations.

Monitor your driving, be on the alert, observe the vehicle surroundings and other traffic and react when needed - risk of accident. ◀



Avoid driving fast with PDC

Avoid approaching an object too fast.

Avoid driving off fast while PDC is not yet active.

For technical reasons, the system may otherwise be too late in issuing a warning. ◀

At a glance

With front PDC: button in vehicle



PDC Park Distance Control

Switching on/off

Switching on automatically

PDC switches on automatically in the following situations:

- ▷ If selector lever position R is engaged while drive readiness is switched on.
The rearview camera also switches on.
- ▷ If equipped with front PDC: when obstacles are detected behind or in front of the vehicle by PDC and the speed is slower than approx. 2 mph/3 km/h.

You may turn off automatic activation:

1. "Settings"
2. "Parking"
3. Select setting.

Settings are stored for the profile currently in use.

Automatic deactivation during forward travel

The system switches off when a certain driving distance or speed is exceeded.

Switch the system back on if needed.

With front PDC: switching on/off manually



Press button.

- ▷ On: the LED lights up.
- ▷ Off: the LED goes out.

The rearview camera image is displayed when the reverse gear is engaged by pressing the button.

Display

Signal tones

When approaching an object, an intermittent sound indicates the position of the object. E. g. if an object is detected to the left rear of the vehicle, a signal tone sounds from the left rear speaker.

The shorter the distance to the object, the shorter the intervals.

If the distance to a detected object is less than approx. 10 in/25 cm, a continuous tone is sounded.

With front PDC: if objects are located both in front of and behind the vehicle, an alternating continuous signal is sounded.

The signal tone is switched off:

- ▷ When the vehicle moves away from an object by more than approx. 4 in/10 cm.
- ▷ When selector lever position P is set.

Volume

The volume of the PDC signal tone can be adjusted similar to the sound and volume settings of the radio.

Settings are stored for the profile currently in use.

Visual warning

The approach of the vehicle to an object can be shown on the Control Display. Objects that are farther away are already displayed on the Control Display before a signal sounds.

A display appears as soon as Park Distance Control (PDC) is activated.

The range of the sensors is represented in the colors green, yellow and red.

When the image of the rearview camera is displayed, the reel can be made to PDC:

 "Rear view camera"

System limits

Limits of ultrasonic measurement

Ultrasonic measuring might not function under the following circumstances:

- ▷ For small children and animals.
- ▷ For persons with certain clothing, e.g. coats.
- ▷ With external interference of the ultrasound, e.g. from passing vehicles or loud machines.
- ▷ When sensors are dirty, iced over, damaged or out of position.
- ▷ Under certain weather conditions such as high relative humidity, rain, snowfall, extreme heat or strong wind.
- ▷ With tow bars and trailer couplings of other vehicles.
- ▷ With thin or wedge-shaped objects.
- ▷ With moving objects.

- ▷ With elevated, protruding objects such as ledges or cargo.
- ▷ With objects with corners and sharp edges.
- ▷ With objects with a fine surface structure such as fences.
- ▷ For objects with porous surfaces.

Low objects already displayed, e.g., curbs, can move into the blind area of the sensors before or after a continuous tone sounds.

False warnings

PDC may issue a warning under the following conditions even though there is no obstacle within the detection range:

- ▷ In heavy rain.
- ▷ When sensors are very dirty or covered with ice.
- ▷ When sensors are covered in snow.
- ▷ On rough road surfaces.
- ▷ On uneven surfaces, such as speed bumps.
- ▷ In large buildings with right angles and smooth walls, e.g., in underground garages.
- ▷ Through heavy pollution.
- ▷ Due to other ultrasound sources, e.g., sweeping machines, high pressure steam cleaners or neon lights.

Malfunction

A Check Control message is displayed.



Red symbol is displayed, and the range of the sensors is dimmed on the Control Display.

PDC has failed. Have the system checked.

To ensure full functionality:

- ▷ Keep the sensors clean and free of ice.
- ▷ dimmedDo not put any stickers on sensors.

- ▷ When using high-pressure washers, do not spray the sensors for long periods and maintain a distance of at least 12 in/30 cm.

Rearview camera

The concept

The rearview camera provides assistance in parking and maneuvering backwards. The area behind the vehicle is shown on the Control Display.

Hints



Check the traffic situation as well

Check the traffic situation around the vehicle with your own eyes. Otherwise, an accident could result from road users or objects that are not detected by the camera. ◀

At a glance

Button in the vehicle



Rearview camera

Camera



The camera lens is located underneath the tailgate. The image quality may be impaired by dirt.

Clean the lens, refer to page 201.

Switching on/off

Switching on automatically

With drive readiness switched on, engage lever in position P R.

Automatic deactivation during forward travel

The system switches off when a certain driving distance or speed is exceeded.

Switch the system back on if needed.

Switching on/off manually



Press button.

- ▷ On: the LED lights up.
- ▷ Off: the LED goes out.

The PDC is shown on the Control Display.

The rearview camera image is displayed when the reverse gear is engaged by pressing the button.

Switching the view via iDrive

With PDC activated:

"Rear view camera"

The rearview camera image is displayed.

Display on the Control Display

Functional requirement

- ▷ The rearview camera is switched on.
- ▷ The tailgate is fully closed.

Activating assistance functions

More than one assistance function can be active at the same time.

- ▷ Parking aid lines
 - P_{P} "Parking aid lines"
 - Lanes and turning radius are indicated.
- ▷ Obstacle marking
 - P_{A} "Obstacle marking"
 - Spatially-shaped markings are displayed.

Pathway lines

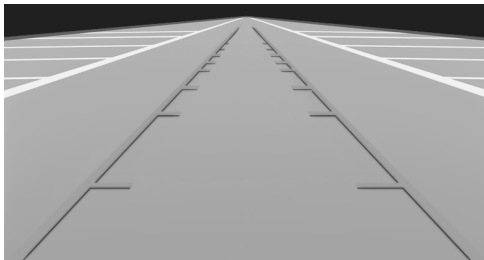

- ▷ Pathway lines can be superimposed on the image of the rearview camera.
- ▷ They help you to estimate how much space is needed when parking and maneuvering on level pavement.
- ▷ They are dependent on the current steering angle and are continuously adjusted to the steering wheel movements.

Turning circle lines

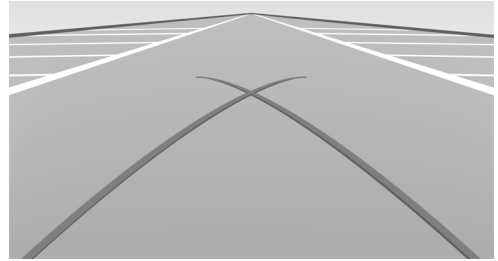

- ▷ Turning circle lines can only be superimposed on the rearview camera image together with pathway lines.
- ▷ They show the course of the smallest possible turning radius on a level road.
- ▷ Only one turning radius line is displayed after the steering wheel is turned past a certain angle.

Obstacle marking

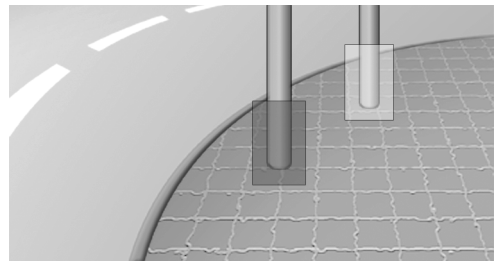

Obstacles behind the vehicle are detected by the PDC sensors and, when respectively equipped, detected by the rearview camera.

Obstacle markings can be faded into the image of the rearview camera.

Their colored margins match the markings of the PDC. This simplifies estimation of the distance to the object shown.

Parking using pathway and turning radius lines

1. Position the vehicle so that the turning radius lines lead to within the limits of the parking space.

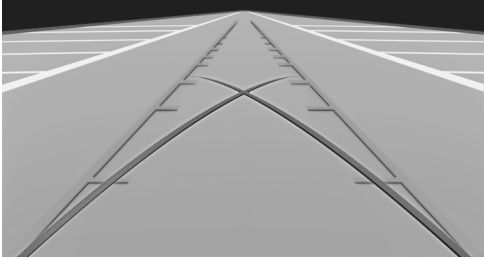

2. Turn the steering wheel to the point where the pathway line covers the corresponding turning radius line.

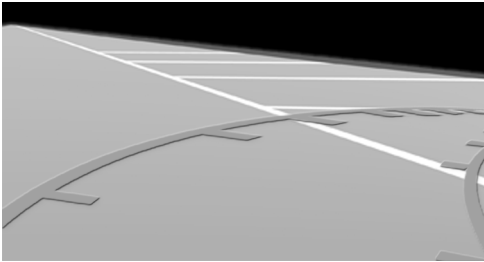

Display settings

Brightness

With the rearview camera switched on:

1. ☀ Select the symbol.
2. Turn the controller until the desired setting is reached, and press the controller.

Contrast

With the rearview camera switched on:

1. ● Select the symbol.
2. Turn the controller until the desired setting is reached, and press the controller.

System limits

Detection of objects

Very low obstacles as well as high, protruding objects such as ledges may not be detected by the system.

Assistance functions also take into account data of the PDC.

Follow instructions in the PDC chapter, refer to page 117.

The objects displayed on the Control Display under certain circumstances are closer than they appear. Do not estimate the distance from the objects on the display.

Parking assistant

The concept

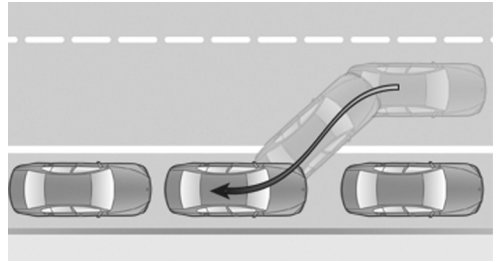

This system assists the driver in parking parallel to the road.

Ultrasound sensors measure parking spaces on both sides of the vehicle.

The parking assistant calculates the best possible parking line and during the parking procedure takes control of steering, the acceleration and braking and if needed changes the gears. Hold down the parking assistant button for the duration of the parking procedure. At the end of the parking procedure, the P selector lever position is set.

When parking, also take note of the visual and acoustic information and instructions issued by the PDC, the parking assistant and the rearview camera and react accordingly.

A component of the parking assistant is the PDC Park Distance Control, refer to page 117.

Hints

 Personal responsibility

Even an active system does not relieve the driver from personal responsibility while driving.

Technically the system has its limits, it cannot independently react to all traffic situations.

Monitor your driving, be on the alert, observe the vehicle surroundings and other traffic and react when needed - risk of accident. ◀

 Changes to the parking space

Changes to the parking space after it was measured are not taken into account by the system.

Therefore, always be alert and ready to intervene; otherwise, there is the risk of an accident. ◀

 Transporting cargo

Cargo that extends beyond the perimeter of the vehicle is not taken into account by the system during the parking procedure.

Therefore, always be alert and ready to intervene; otherwise, there is the risk of an accident. ◀

 Curbs

The parking assistant may steer the vehicle over or onto curb if need be.

Therefore, always be alert and ready to intervene; otherwise, the wheels, tires, or the vehicle may become damaged. ◀

Requirements

For measuring parking spaces

- ▷ Maximum speed while driving forward approx. 22 mph/35 km/h.

- ▷ Maximum distance to row of parked vehicles: 5 ft/1.5 m.

Suitable parking space

- ▷ Gap between two objects with a minimum length of approx. 5 ft/1.5 m.
- ▷ Min. length of gap between two objects: your vehicle's length plus approx. 4 ft/1.2 m.
- ▷ Minimum depth: approx. 5 ft/1.5 m.

Regarding the parking procedure

- ▷ Doors and tailgate closed.
- ▷ Parking brake released.
- ▷ Driver's safety belt fastened.

At a glance

Button in the vehicle



 Parking assistant

Ultrasound sensors

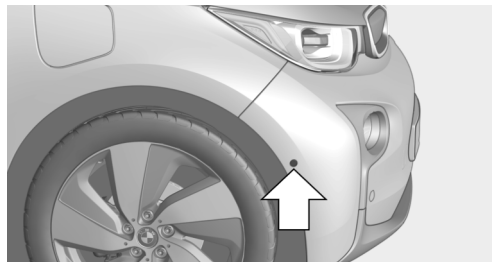

The ultrasound sensors for measuring parking spaces are located on the side of the vehicle.

To ensure full functionality:

- ▷ Keep the sensors clean and free of ice.
- ▷ When using high-pressure washers, do not spray the sensors for long periods and maintain a distance of at least 12 in/30 cm.
- ▷ Do not put stickers over sensors.

Switching on/off

Switching on with the button



Press button.

The LED lights up.

The current status of the parking space search is indicated on the Control Display.

Parking assistant is activated automatically.

Switching on with selector lever position R

Engage selector lever position R.

The current status of the parking space search is indicated on the Control Display.

To activate: "Parking Assistant"

Switch off

The system can be deactivated as follows:

- ▷ Press button.

Display on the Control Display

System activated/deactivated

Symbol	Meaning
	Gray: the system is not available. White: the system is available but not activated.
	The system is activated.

System status

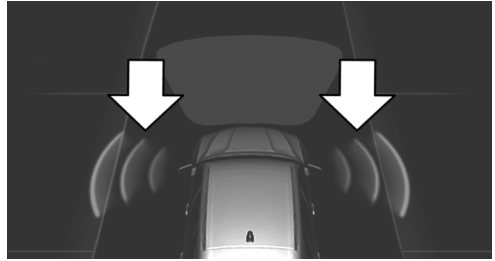

- ▷ Colored symbols, see arrows, on the side of the vehicle illustrated. Parking assistant is activated and search for parking space active.
- ▷ Control Display shows suitable parking spaces at the edge of the road next to the vehicle symbol. When the parking assistant is active, suitable parking spaces are highlighted.

- ▷ The parking procedure is active. Steering control has been taken over by system.

- ▷ Parking space search is always active whenever the vehicle is moving forward slow and straight, even if the system is deactivated. When the system is deactivated, the displays on the Control Display are shown in gray.

Parking using the parking assistant



Check the traffic situation as well

Loud noises outside and inside the vehicle can drown out the parking assistant's and PDC's signals.

Check the traffic situation around the vehicle with your own eyes; otherwise, there is a danger of an accident. ◀



1. Switch on the parking assistant and activate it if needed.

The status of the parking space search is indicated on the Control Display.

2. Follow the instructions on the Control Display.
The end of the parking procedure is indicated on the Control Display.
3. Adjust the parking position yourself if needed.

Interrupting manually

The parking assistant can be interrupted at any time:

- ▷  "Parking Assistant" Select the symbol on the Control Display.
- ▷  Press button.

Interrupting automatically

The system is interrupted automatically in the following situations:

- ▷ If the driver grasps the steering wheel or if he takes over steering.
 - ▷ Possible on snow-covered or slippery road surfaces.
 - ▷ When there are obstacles that are hard to overcome, such as curbs.
 - ▷ When there are obstacles that suddenly arise.
 - ▷ If the Park Distance Control PDC displays clearances that are too small.
 - ▷ If a maximum number of parking attempts or the time taken for parking is exceeded.
 - ▷ When switching to another function on the Control Display.
 - ▷ When the button is released.
 - ▷ If the tailgate is open.
 - ▷ If doors are open.
 - ▷ When setting the parking brake.
 - ▷ During acceleration.
 - ▷ When braking.
 - ▷ When unfastening the driver's safety belt.
- A Check Control message is displayed.

Resume

An interrupted parking procedure can be continued if needed.

Follow the instructions on the Control Display to do this.

System limits

No parking assistance

The parking assistant does not offer assistance in the following situations:

- ▷ In tight curves.

Functional limitations

The system may not be fully functional in the following situations:

- ▷ On bumpy road surfaces such as gravel roads.
- ▷ On slippery ground.
- ▷ On steep uphill or downhill grades.
- ▷ With accumulations of leaves/snow in the parking space.

Limits of ultrasonic measurement

Ultrasonic measuring might not function under the following circumstances:

- ▷ For small children and animals.
- ▷ For persons with certain clothing, e.g. coats.
- ▷ With external interference of the ultrasound, e.g. from passing vehicles or loud machines.
- ▷ When sensors are dirty, iced over, damaged or out of position.
- ▷ Under certain weather conditions such as high relative humidity, rain, snowfall, extreme heat or strong wind.
- ▷ With tow bars and trailer couplings of other vehicles.
- ▷ With thin or wedge-shaped objects.
- ▷ With moving objects.

- ▷ With elevated, protruding objects such as ledges or cargo.
- ▷ With objects with corners and sharp edges.
- ▷ With objects with a fine surface structure such as fences.
- ▷ For objects with porous surfaces.

Low objects already displayed, e.g., curbs, can move into the blind area of the sensors before or after a continuous tone sounds.

The parking assistant may identify parking spaces that are not suitable for parking.

Malfunction

A Check Control message is displayed.

The parking assistant failed. Have the system checked.

Climate control

Vehicle features and options

This chapter describes all standard, country-specific and optional features offered with the series. It also describes features that are not

necessarily available in your car, e. g., due to the selected options or country versions. This also applies to safety-related functions and systems.

Air conditioner

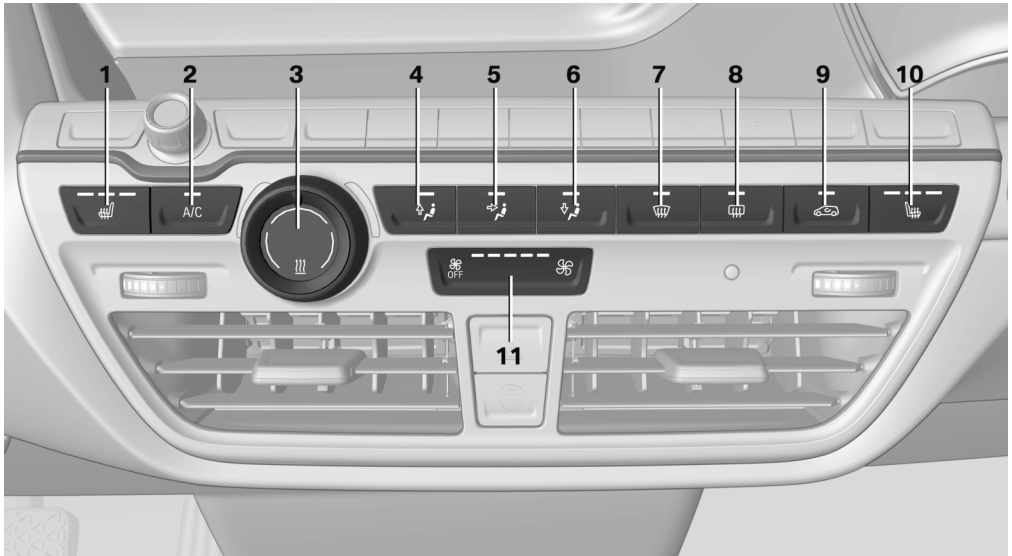

- | | | | |
|---|-------------------------------------|----|-----------------------------|
| 1 | Seat heating, left 52 | 7 | Remove ice and condensation |
| 2 | Cooling function | 8 | Rear window defroster |
| 3 | Temperature | 9 | Recirculated-air mode |
| 4 | Air distribution, windows | 10 | Seat heating, right 52 |
| 5 | Air distribution, upper body region | 11 | Air flow |
| 6 | Air distribution, footwell | | |

Hints

 Sufficient ventilation

When remaining in the vehicle for an extended period of time, ensure sufficient external ventilation. Do not continuously use recir-

culated-air mode; otherwise the air quality in the interior continuously worsens. ◀

Climate control functions in detail

Cooling function

Cooling of the interior with the A/C button is only possible with drive readiness switched on.

 Press button.

The air will be cooled and dehumidified and, depending on the temperature setting, warmed again.

The air conditioner produces condensation water, refer to page 147, that will exit from below the car.

Temperature



Turn the ring to set the desired temperature.

The air conditioner regulates this temperature and then holds it constant.

To reduce the energy consumption, the cooling or heating output is reduced or deactivated as per ECO-PRO mode, refer to page 151.

Manual air distribution

Press buttons repeatedly to select a program:

▷  Windows.

▷  Upper body region.

▷  Footwell.

You may combine these programs as needed.

Defrosts windows and removes condensation

 Press button.

Ice and condensation are quickly removed from the windshield and the front side windows.

Adjust air flow with the program active.

If the windows are fogged over, you can also reel on the cooling function to dehumidify the air.

Rear window defroster



Press button.

The rear window defroster switches off automatically after a certain period of time.

Recirculated-air mode

You may respond to unpleasant odors or pollutants in the immediate environment by temporarily suspending the supply of outside air. The system then recirculates the air currently within the vehicle.



Press button repeatedly to select an operating mode:

- ▷ LED off: outside air flows in continuously.
- ▷ LED on, recirculated-air mode: the supply of outside air into the vehicle is permanently blocked.

To prevent window fogging, recirculated air mode switches off automatically after a certain amount of time, depending on the environmental conditions.

If the windows fog over, reel off recirculated-air mode and increase the air flow, if needed.



Sufficient ventilation

When remaining in the vehicle for an extended period of time, ensure sufficient external ventilation. Do not continuously use recirculated-air mode; otherwise the air quality in the interior continuously worsens. ◀

Air flow, manual



Press the left or right side of the button: decrease or increase air flow.

The intensity is indicated through LEDs. The highest level is active when five LEDs are lit.

The air flow from the air conditioner may be reduced automatically to save battery power.

- ▷ Rear window defroster.
- ▷ Seat heating.

Switching the system on/off

Switch off



Press and hold the left button until the control switches off.

Switching on

Press any button except

Microfilter

In external and recirculated air mode the microfilter filters dust and pollen from the air.

This filter should be replaced during scheduled maintenance, refer to page 185, of your vehicle.

Automatic climate control

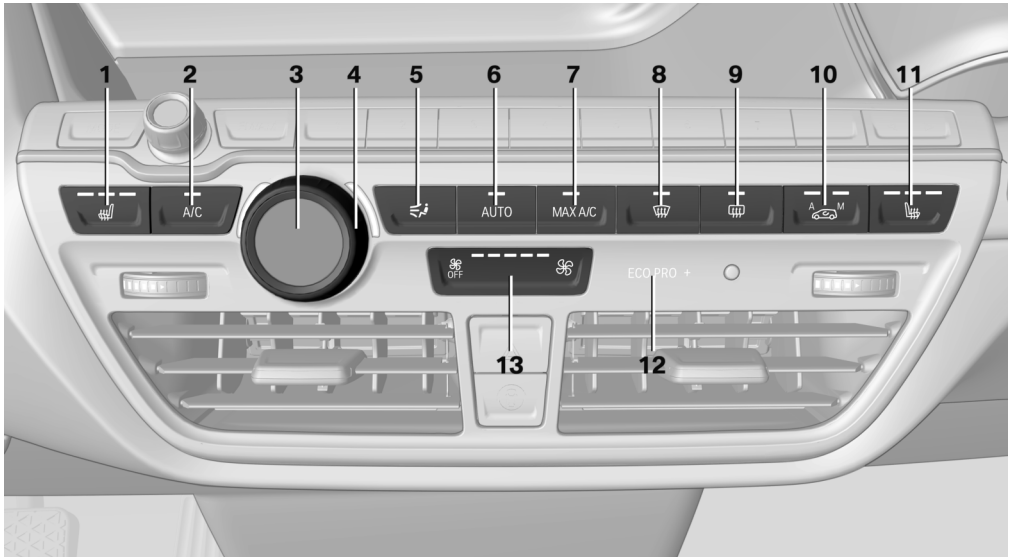

- | | |
|---|--|
| <ul style="list-style-type: none"> 1 Seat heating, left 52 2 Cooling function 3 Display 4 Temperature 5 Vent settings 6 AUTO program 7 Maximum cooling | <ul style="list-style-type: none"> 8 Remove ice and condensation 9 Rear window defroster 10 Automatic recirculated-air control/recirculated-air mode 11 Seat heating, right 52 12 Activated driving mode display 151 13 Air flow, AUTO intensity |
|---|--|

Hints



Sufficient ventilation

When remaining in the vehicle for an extended period of time, ensure sufficient external ventilation. Do not continuously use recirculated-air mode; otherwise the air quality in the interior continuously worsens. ◀

Climate control functions in detail

Cooling function

The car's interior can be cooled with the stationary climate control or via the A/C button with drive readiness activated.



Press button.

The air will be cooled and dehumidified and, depending on the temperature setting, warmed again.

Depending on the weather, the windshield and side windows may fog up briefly when drive readiness is activated.

The cooling function is switched on automatically with the AUTO program.

When using the automatic climate control, condensation water, refer to page 147, develops that exits underneath the vehicle.

Temperature



Turn the ring to set the desired temperature.

The selected temperature is shown on the display of the automatic climate control.

The automatic climate control reaches this temperature as quickly as possible, if needed by increasing the cooling or heating output, and then keeps it constant.

Do not rapidly switch between different temperature settings. Otherwise, the automatic cli-

mate control will not have sufficient time to adjust the set temperature.

To reduce the energy consumption, the cooling or heating output is reduced or deactivated as per ECO-PRO mode, refer to page 151.

Manual air distribution



Press button repeatedly to select a program:

- ▷ Windows.
- ▷ Upper body region.
- ▷ Footwell.
- ▷ Windows and upper body region.
- ▷ Windows and footwell.
- ▷ Upper body region and footwell.
- ▷ Windows, upper body region, and footwell.

The selected air distribution is shown on the display of the automatic climate control.

If the windows are fogged over, press the AUTO button to utilize the condensation sensor.

AUTO program



Press button.

Air flow, air distribution and temperature are controlled automatically.

Depending on the selected temperature, AUTO intensity program and outside influences, the air is directed to the windshield, side windows, upper body, and into the footwell.

The cooling function, refer to page 130, is switched on automatically with the AUTO program.

At the same time, a condensation sensor controls the program so as to prevent window condensation as much as possible.

To reel off the program: press the button again or manually adjust the air distribution.

Intensity of the AUTO program

With the AUTO program activated, the automatic intensity control can be changed.



Press the left or right side of the button: decrease or increase the intensity.

The intensity level is indicated through LEDs.

Maximum cooling



Press button.

The system is set to the lowest temperature, optimum air flow and air circulation mode.

Air flows out of the vents to the upper body region. The vents need to be open for this.

The function is available above an external temperature of approx. 32 °F/0 °C and when drive readiness is indicated.

If ECO PRO+, refer to page 151, is activated, this function is deactivated.

Adjust air flow with the program active.

Defrosts windows and removes condensation



Press button.

Ice and condensation are quickly removed from the windshield and the front side windows.

For this purpose, point the side vents onto the side windows as needed.

Adjust air flow with the program active.

If the windows are fogged over, you can also reel on the cooling function or press the AUTO button to utilize the condensation sensor.

Rear window defroster



Press button.

The rear window defroster switches off automatically after a certain period of time.

Automatic recirculated-air control/ recirculated-air mode

You may respond to unpleasant odors or pollutants in the immediate environment by temporarily suspending the supply of outside air. The system then recirculates the air currently within the vehicle.



Press button repeatedly to select an operating mode:

- ▶ LEDs off: outside air flows in continuously.
- ▶ Left LED on, automatic recirculated-air control: a sensor detects pollutants in the outside air and shuts off automatically.
- ▶ Right LED on, recirculated-air mode: the supply of outside air into the vehicle is permanently blocked.

To prevent window fogging, recirculated air mode switches off automatically after a certain amount of time, depending on the environmental conditions.

If the windows are fogged over, reel off the recirculated-air mode and press the AUTO button to utilize the condensation sensor. Make sure that air can flow to the windshield.



Sufficient ventilation

When remaining in the vehicle for an extended period of time, ensure sufficient external ventilation. Do not continuously use recirculated-air mode; otherwise the air quality in the interior continuously worsens. ◀

Air flow, manual

To manually adjust air flow turn off AUTO program first.



Press the left or right side of the button: decrease or increase air flow.

The intensity is indicated through LEDs. The highest level is active when five LEDs are lit.

The air flow of the automatic climate control may be reduced automatically to save battery power.

Switching the system on/off

Switch off



Press and hold the left button until the control switches off.

Switching on

Press any button except

- ▷ Rear window defroster.
- ▷ Seat heating.

Microfilter/activated-charcoal filter

In external and recirculated air mode the microfilter/activated charcoal filter filters dust, pollen, and gaseous pollutants out of the air.

This filter should be replaced during scheduled maintenance, refer to page 185, of your vehicle.

Ventilation

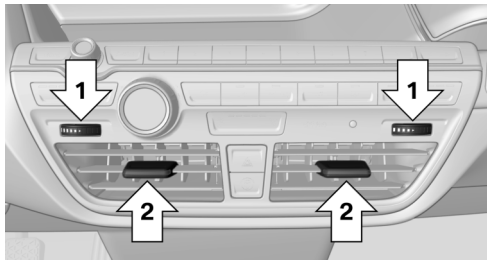

- ▷ Thumbwheels for opening and closing the vents continuously, arrows 1.
- ▷ Lever for changing the air flow direction, arrow 2.

Adjusting the ventilation

- ▷ Ventilation for cooling:
Direct vent in your direction when vehicle's interior is too hot.
- ▷ Draft-free ventilation:
Adjust the vent to let the air flow past you.

Stationary climate control

The concept

Stationary climate control cools or heats the interior prior to departure to a comfortable temperature.

The interior temperature is lowered with high cooling output.

The system may heat the interior. Snow and ice can be removed more easily.

The air automatically exits through the vents to the windshield, the side windows, the upper body region and into the footwell.

The stationary climate control can be switched on and off via the following systems:

- ▷ Direct operation, refer to page 132.
- ▷ Preselected departure times, refer to page 133.

With the BMW i Remote App, refer to page 133, the standing air conditioning can be switched on.

The system switches off automatically at the latest after 30 minutes.

Functional requirements

- ▷ When the departure time is preselected: depends on internal, external and set temperature.
- ▷ Direct operation via iDrive: any external temperature.
- ▷ The high-voltage battery is sufficiently charged.
- ▷ Drive readiness is deactivated.
- ▷ The vents are open to allow air to flow out.

Switching on/off directly

On the Control Display:

1. "Settings"
2. "Climate"
3. "Activate comfort climate control"

⌘ The symbol on the automatic climate control flashes if the stationary climate control is switched on.

Activate climate control at departure time

The reel-on time is automatically determined based on the temperature. The system promptly switches on before the selected departure time.

On the Control Display:

1. "Settings"
2. "Departure time"
3. "Precondition for departure time"
4. "Departure 1:"
5. Set and activate Desired departure time, refer to page 163.

⌘ The symbol on the automatic climate control lights up when the departure time is activated.

⌘ The symbol on the automatic climate control flashes when the stationary climate control has been switched on.

If drive readiness is switched off, changes can be made on the Control Display. Departure time can only be changed once. Scheduled departure times are not adjusted. Settings for climate control and charging operation are also applied for scheduled departure times.

Activating with BMW i Remote app

With the BMW i remote app, refer to Owner's Handbook regarding BMW i remote, the system can be switched on immediately or at a preselected departure time.

Interior equipment

Vehicle features and options

This chapter describes all standard, country-specific and optional features offered with the series. It also describes features that are not necessarily available in your car, e. g., due to the selected options or country versions. This also applies to safety-related functions and systems.

Sun visor

Glare shield

Fold the sun visor down or up.

Vanity mirror

A vanity mirror is located in the sun visor behind a cover. When the cover is opened, the mirror lighting switches on.

Ashtray/cigarette lighter

Ashtray

Opening



The ashtray can be inserted in the cupholder.

Emptying

Take out the insert.

Lighter

 Danger of burns

Only hold the hot lighter by its knob; otherwise, there is a danger of getting burned.

Switch off operating readiness and take the remote control with you when leaving the vehicle so that children cannot use the lighter and burn themselves. ◀

 Replace the cover after use

Reinsert the lighter or socket cover after use, otherwise objects may get into the lighter socket or fixture and cause a short circuit. ◀



Push in the lighter.

The lighter can be removed as soon as it pops back out.

Connecting electrical devices

Hints

 Do not connect charging devices to the 12 volt socket in the vehicle

Do not connect battery chargers to the factory-installed 12 volt sockets in the vehicle as this may damage the vehicle battery due to an increased power consumption. ◀

 Replace the cover after use

Reinsert the lighter or socket cover after use, otherwise objects may get into the lighter socket or fixture and cause a short circuit. ◀

Sockets

General information

The lighter socket can be used as a socket for electrical equipment when operating and drive readiness are activated.

Note

The total load of all sockets must not exceed 140 watts at 12 volts.

Do not damage the socket by using unsuitable connectors.

Front center console



The socket is located between the front seats. Remove the cover or cigarette lighter.

In the cargo area



The socket is located on the right side in the cargo area.

USB interface for data transfer

The concept

Connection for importing and exporting data on USB devices, e.g.:

- ▷ Personal Profile settings, refer to page 37.
- ▷ Music collection.
- ▷ Importing Trips.

Hints

Observe the following when connecting:

- ▷ Do not use force when plugging the connector into the USB interface.
- ▷ Do not connect devices such as fans or lights to the USB interface.
- ▷ Do not connect USB hard drives.
- ▷ Do not use the USB interface for recharging external devices.

At a glance



The socket is located between the front seats.

Cargo area

Cargo cover

General information

The cargo cover is raised when the tailgate is opened.

Note

-  Do not deposit heavy objects
Do not deposit heavy or hard objects on the cargo cover. Otherwise, they may pose a risk to occupants, such as during braking and evasive maneuvers. ◀

Removing

The cover can be removed to load bulky luggage.

1. Detach the retaining straps at the tailgate.
2. Raise the cover and pull it back to remove.

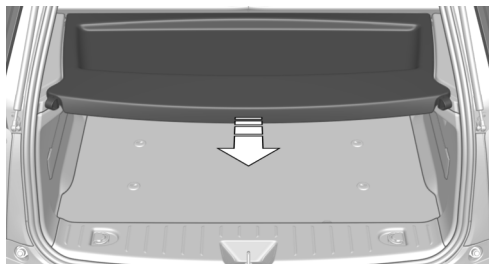

Installing

1. Place the cover in the brackets.
2. Attach the retaining straps.

Enlarging the cargo area

General information

The cargo area can be enlarged by folding down the rear seat backrest.

Hints

-  **Danger of jamming**
Before folding down the rear seat backrests, ensure that the area of movement of the backrests is clear. Ensure that no one is located in or reaches into the area of movement of the rear seat backrests. Otherwise, injury or damage may result. ◀

-  **Ensuring the stability of the child seat**
When installing child restraint systems, make sure that the child seat is securely fastened to the backrest of the seat. Angle and headrest of the backrest might need to be adjusted or possibly be removed. Make sure that all backrests are securely locked. Otherwise the stability of the child seat can be affected, and there is an increased risk of injury because of unexpected movement of the rear seat backrest. ◀

-  **Ensure that the lock is securely engaged**
When you fold back the backrest make sure that it locks in place. The red mark on the front loop must disappear. Otherwise transported cargo could shoot into the car's interior during braking or evasive maneuvers and endanger occupants. ◀

-  **Fold in headrests, before rear seat backrests are folded down**

Before folding down the rear seat backrests, make sure that the corresponding headrest is pushed all the way down and folded away; otherwise, damage may result. ◀

Folding down rear seat backrest

-  **Only use loops for releasing the rear seat backrests**

Do not use the loops for releasing the rear seat backrests to attach objects; otherwise there is an increased risk of injury because of unexpected movement of the rear seat backrest. ◀

The rear seat backrest can be folded down from the front or from the cargo area.

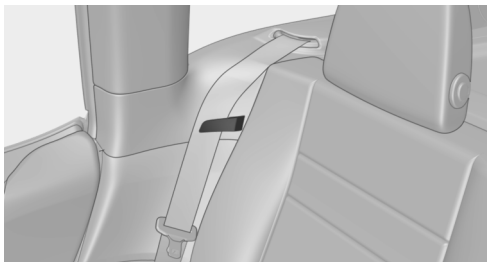

Before folding down the backrest, make sure that the belt is located in the belt buckle.

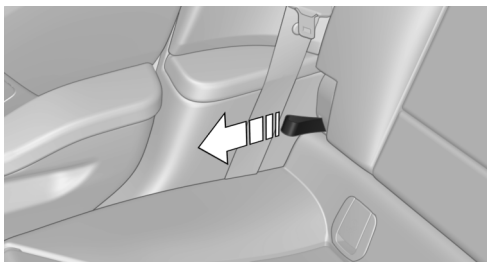

Pull the corresponding loop on the seat backrest forward.

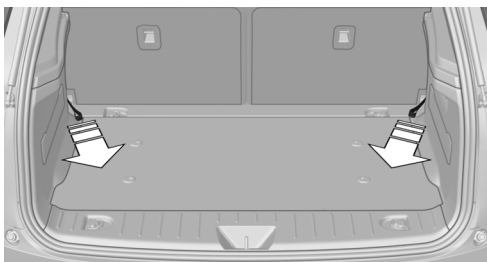

Or: pull the corresponding loop in the cargo area and fold the seat backrest forward.

To secure cargo, refer to page 149, with nets or draw straps, the cargo area is fitted with lashing eyes.

Loading position of the rear seat backrest

The rear seat backrests can be individually set in two different positions.

To expand the cargo area, the rear seat backrest can be moved into a vertical position.

1. Pull corresponding loop.
2. Set the loading position of the seat backrest.
3. Latch the rear seat backrest. The red mark on the front loop must disappear.

Rear seat backrest basic position

When folding back the backrests from the folded down position, first latch them in the loading position.

1. Pull corresponding loop.
2. Fold the rear seat backrest rearward.
3. Pull loop again.
4. Fold rear seat backrest all the way back.
5. Latch the rear seat backrest. The red mark on the front loop must disappear.

Storage compartments

Vehicle features and options

This chapter describes all standard, country-specific and optional features offered with the series. It also describes features that are not necessarily available in your car, e. g., due to the selected options or country versions. This also applies to safety-related functions and systems.

Hints

 No loose objects in the car's interior
Do not stow any objects in the car's interior without securing them; otherwise, they may present a danger to occupants e.g., during braking and evasive maneuvers. ◀

 Do not place anti-slip mats on the dashboard

Do not place anti-slip mats on the dashboard. The mat materials could damage the dashboard. ◀

Storage compartments

The following storage compartments are available in the vehicle interior:

- ▷ Glove compartment on the front passenger side, refer to page 138.
- ▷ Storage compartment between the front seats behind the cupholder.
- ▷ Storage compartment in the front center armrest, refer to page 139.
- ▷ Compartments in the front doors, refer to page 138.
- ▷ Storage compartment between the rear seats.

Glove compartment

Front passenger side

Note

 Close the glove compartment again immediately

Close the glove compartment immediately after use while driving; otherwise, injury may occur during accidents. ◀

Opening

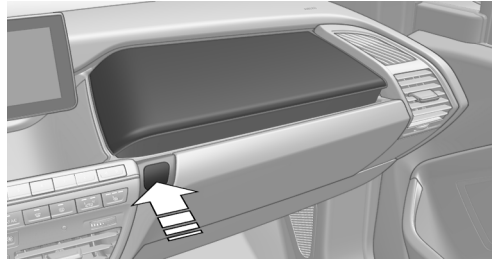

Press button and open cover upward.

Closing

Fold cover closed.

Compartments in the doors

 Do not stow any breakable objects
Do not store any breakable objects, e. g. glass bottles, in the compartments, or there is an increased risk of injury in the event of an accident. ◀

Center armrest

Open/tilt

A storage compartment is located in the center armrest between the front seats.

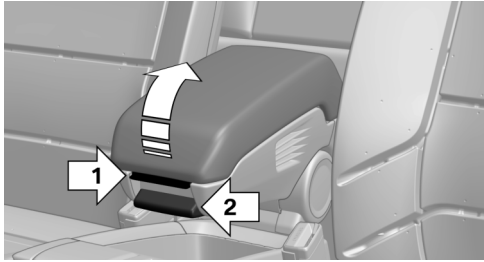

To open, press button, arrow 1.

To open, press button, arrow 2.

Connection for an external audio device



An external audio device, e.g., an MP3 player, can be connected via the AUX-IN port or the USB audio interface in the center armrest.

Receptacle for cupholder

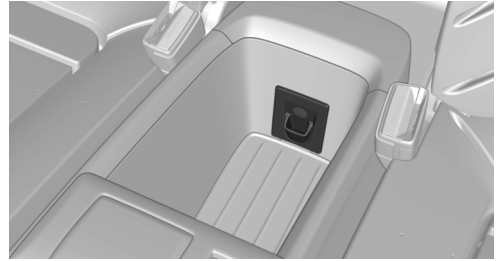

A storage compartment with a receptacle for a cupholder is located underneath the center armrest.

Cupholders

Hints



Shatter-proof containers and no hot drinks

Use light and shatter-proof containers and do not transport hot drinks. Otherwise, there is the increased danger of injury in an accident. ◀



Unsuitable containers

Do not forcefully push unsuitable containers into the cupholders. This may result in damage. ◀

Front

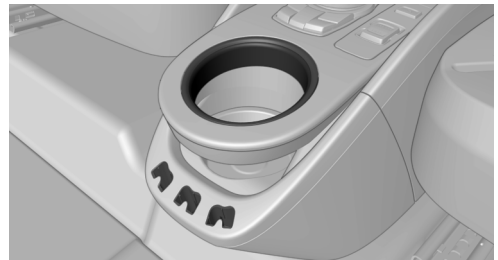

Between the seats.

Removing



Using the heel of your hand, pry the cupholder out of the bracket.

Rear

Between the seats.

Clothes hooks

 Do not obstruct view

When suspending clothing from the hooks, ensure that it will not obstruct the driver's view. ◀

 No heavy objects

Do not hang heavy objects from the hooks; otherwise, they may present a danger to passengers during braking and evasive maneuvers. ◀

The clothes hooks are located on the roofliner above the rear doors.

Storage compartments in the cargo area

Retaining strap

A retaining strap is available on the right and left side trim for fastening small objects.

Lashing eyes in the cargo area

To secure the cargo, refer to page 149, there are four lashing eyes in the cargo area.



Driving tips

This chapter provides you with information useful in dealing with specific driving and operating modes.

Things to remember when driving

Vehicle features and options

This chapter describes all standard, country-specific and optional features offered with the series. It also describes features that are not necessarily available in your car, e. g., due to the selected options or country versions. This also applies to safety-related functions and systems.

Breaking-in period

General information

Moving parts need time to adjust to one another (break-in time).

The following instructions will help accomplish a long vehicle life and good efficiency.

Range Extender

The full performance of the Range Extender is available after a brief operating period and is only minimally restricted during the run-in phase.

Control of the Range Extender during and after the run-in phase, as well as the activation of the full performance, are preset depending on the system and take place automatically.

Tires

Tire traction is not optimal due to manufacturing circumstances when tires are brand-new; they achieve their full traction potential after a break-in time.

Drive conservatively for the first 200 miles/300 km.

Brake system

Brakes require an initial break-in period of approx. 300 miles/500 km to achieve optimal performance between brake discs and brake

pads. Drive moderately during this break-in period.

Following part replacement

The same break-in procedures should be observed if any of the components above-mentioned have to be renewed in the course of the vehicle's operating life.

Using eDRIVE efficiently

The concept

eDRIVE operates automatically. Proactive driving utilizes energy consumption and energy recovery optimally. Energy recovery is used to charge the high-voltage battery. It is important for the supply of electrical components and thus a prerequisite for an extensive range. Energy consumption and recovery depend very much, among other things, on your driving style.

Optimizing driving style

Performance display

The driving style can be optimized using the performance display.

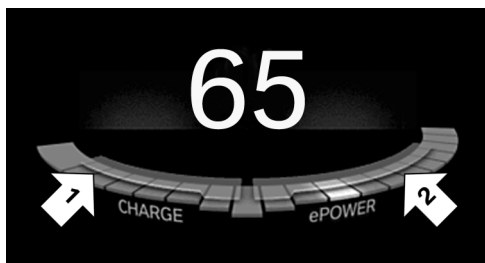

The energy recovery occurs during coasting and braking and is displayed in the performance display by the accelerator pedal indicator.

The accelerator pedal pointer is within the CHARGE range.

Efficient energy recovery:

- ▷ The accelerator pedal moves to the left within the blue range of the CHARGE display, arrow 1.
- ▷ The energy use while driving can be optimized by efficient acceleration.

Efficient acceleration:

- ▷ The accelerator pedal moves to the right within the blue range of the ePOWER display, arrow 2.
- ▷ Use deceleration during coasting as often as possible for energy recovery.

 Brake according to traffic and circumstances

Brake in accordance with the traffic conditions, or there is the risk of accident. ◀

Discharge of the high-voltage battery

Longer idle periods can reduce the charge state of the high-voltage battery.

 Do not allow the vehicle to sit idle for extended periods with a low charging state

Before storing the vehicle for an extended period, check the battery charge indicator to ensure that the high-voltage battery is fully charged. During the idle period, connect the vehicle to a charging station at a suitable charging location. If necessary, the high-voltage battery will be charged automatically. Make sure that the charging process takes place. Regularly check the charging state. Don't allow battery charge status to drop too low - it will damage the battery. ◀

General driving notes

Closing the tailgate

 Drive with the tailgate closed

Only drive with the tailgate closed; otherwise, in the event of an accident or braking and evasive maneuvers, passengers and other traffic may be injured, and the vehicle may be damaged. Moreover, exhaust gases can get into the vehicle interior and the lights in the tailgate cannot be recognized. ◀

If driving with the tailgate open cannot be avoided:

- ▷ Close all windows and the glass sunroof.
- ▷ Greatly increase the air flow from the vents.
- ▷ Drive moderately.

Hot exhaust system

 Hot exhaust system

High temperatures are generated in the exhaust system.

Do not remove the heat shields installed and never apply undercoating to them. Make sure that flammable materials, e. g. hay, leaves, grass, etc. do not come in contact with the hot exhaust system while driving, while in idle position mode, or when parked. Such contact could lead to a fire, resulting in an increased risk of serious personal injury as well as property damage.

Do not touch hot exhaust pipes; otherwise, there is a danger of getting burned. ◀

Mobile communication devices in the vehicle

 Mobile communication devices in the vehicle

It is not recommended to use mobile phones, such as mobile phones, in the vehicle interior without a direct connection to an external aerial. Otherwise, the vehicle's electronics and mobile communication devices can interfere

with each other. In addition, there is no assurance that the radiation generated during transmission will be conducted away from the vehicle interior. ◀

Hydroplaning

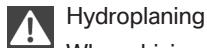

Hydroplaning

When driving on wet or slushy roads, reduce your speed to prevent hydroplaning. ◀

On wet or slushy roads, a wedge of water can form between the tires and road surface.

This phenomenon is referred to as hydroplaning. It is characterized by a partial or complete loss of contact between the tires and the road surface, ultimately undermining your ability to steer and brake the vehicle.

Driving through water



Observe water level and speed

Do not exceed the maximum water level and maximum speed; otherwise, the vehicle's engine, the electrical systems and the transmission may be damaged. ◀

Drive through calm water only and only if it is not deeper than 9.8 inches/25 cm and at this height, no faster than walking speed, up to 3 mph/5 km/h.

Braking safely

Your vehicle is equipped with ABS as a standard feature.

Applying the brakes fully is the most effective way of braking in situations needed.

Steering is still responsive. You can still avoid any obstacles with a minimum of steering effort.

Pulsation of the brake pedal and sounds from the hydraulic circuits indicate that ABS is in its active mode.

In certain braking situations, the perforated brake discs can cause functional problems.

However, this has no effect on the performance and operational reliability of the brake.

Objects in the range of movement of the pedals and in the footwell



Do not allow objects in the interior around pedals and foot space

Keep floor mats, carpets, and any other objects out of the pedal area and do not stow them in the footwell; otherwise, the function of the pedals could be impeded while driving.

Do not place additional floor mats over existing mats or other objects.

Only use floor mats that have been approved for the vehicle and can be properly attached to floor.

Ensure that the floor mats are securely fastened again after they were removed for cleaning, e.g. ◀

Hills



Avoid stressing the brakes

Avoid placing excessive stress on the brake system. Light but consistent brake pressure can lead to high temperatures, brakes wearing out and possibly even brake failure. ◀



Do not drive in neutral

Do not drive in neutral or with drive readiness switched off, as doing so disables engine braking. In addition, steering and brake assist are unavailable with the engine stopped. ◀

On downhill sections, use energy recovery if possible to decelerate the vehicle.

Brake disc corrosion

Brake disc corrosion and contamination of the brake pads are favored by:

- ▶ Low mileage.
- ▶ Extended periods when the vehicle is not used at all.
- ▶ Infrequent use of the brakes.

Corrosion will built up when the maximum pressure applied to the brake pads during braking is not reached - thus discs don't get cleaned.

Corrosion buildup on the brake discs will cause a pulsating effect on the brakes in their response - generally that cannot be corrected.

Condensation under the parked vehicle

When using the automatic climate control, condensation water develops collecting underneath the vehicle.

These traces of water under the vehicle are normal.

Loading

Vehicle features and options

This chapter describes all standard, country-specific and optional features offered with the series. It also describes features that are not necessarily available in your car, e. g., due to the selected options or country versions. This also applies to safety-related functions and systems.

Hints

 **Overloading the vehicle**
To avoid exceeding the approved capacity of the tires, never overload the vehicle. Overloading can lead to overheating and increases the rate at which damage develops inside the tires. This could result in a sudden loss of tire inflation pressure. ◀

 **No fluids in the cargo area**
Make sure that fluids do not leak into the cargo area; otherwise, the vehicle may be damaged. ◀

 **Heavy and hard objects**
Do not stow any heavy and hard objects in the car's interior without securing them; otherwise, they may present a danger to occupants, e.g., during braking and evasive maneuvers. ◀

 **Load cargo area only with the cargo area floor installed**

Load the cargo area only if the cargo area floor is located in the cargo area. Otherwise, the cover of the engine below it could be damaged. ◀

 Only use loops for releasing the rear seat backrests

Do not use the loops for releasing the rear seat backrests to attach objects; otherwise there is an increased risk of injury because of unexpected movement of the rear seat backrest. ◀

Determining the load limit

1. Locate the following statement on your vehicle's placard:
 - ▶ The combined weight of occupants and cargo should never exceed XXX kg or YYY lbs. Otherwise, damage to the vehicle and unstable driving situations may result.

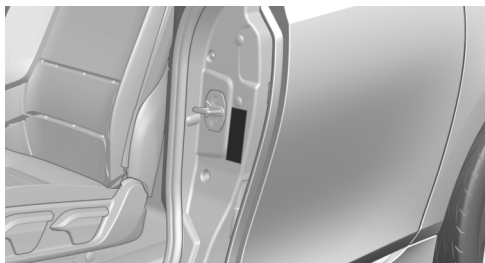

2. Determine the combined weight of the driver and passengers that will be riding in your vehicle.
3. Subtract the combined weight of the driver and passengers from XXX kilograms or YYY pounds.
4. The resulting figure equals the available amount of cargo and luggage load capacity.

For example, if the YYY amount equals 1,000 lbs and there will be four 150 lbs passengers in your vehicle, the amount of available cargo and luggage load capacity

is 400 lbs: 1,000 lbs minus 600 lbs = 400 lbs.

- Determine the combined weight of luggage and cargo being loaded on the vehicle. That weight may not safely exceed the available cargo and luggage load capacity calculated in Step 4.

Load

1 person + 4 suitcases ≤ Max. Load
 3 people + 3 suitcases ≤ Max. Load
 4 people + 1 suitcase ≤ Max. Load

The maximum load is the sum of the weight of the occupants and the cargo.

The greater the weight of the occupants, the less cargo that can be transported.

Stowing cargo

- Do not exceed permissible rear axle load.
- Cover sharp edges and corners on the cargo.
- Heavy cargo: stow as far forward as possible, directly behind and at the bottom of the rear passenger seat backrests.
- Very heavy cargo: when the rear seat is not occupied, secure each of the safety belts in the opposite buckle.
- If necessary, fold down the rear backrests to stow cargo.
- Do not stack cargo above the top edge of the backrests.

Securing cargo

Lashing eyes in the cargo area

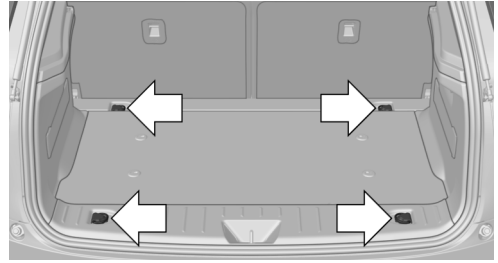

To secure the cargo there are four lashing eyes in the cargo area.

Securing cargo

- Smaller and lighter items: secure with retaining straps or draw straps.
- Larger and heavy objects: secure with cargo straps.

Attach the cargo straps, retaining straps or draw straps to the lashing eyes in the cargo area.



Securing cargo

Stow and secure the cargo as described above; otherwise it may present a danger to the occupants, e.g., during braking and evasive maneuvers. ◀

Increase range

General information

The vehicle contains comprehensive technologies for reducing the energy consumption and for maximizing the range.

The range depends on a number of different factors.

The implementation of certain measures, driving style and regular maintenance can increase range and thereby also reduce the environmental impact.

Remove unnecessary cargo

Additional weight reduces the range.

Remove attached parts following use

Attached parts on the vehicle impair the aerodynamics and increase the energy consumption.

Close the windows and glass sunroof

Driving with the glass sunroof and windows open results in increased air resistance and thereby reduces the range.

Tires

General information

Tires can affect energy consumption in various ways, for instance energy consumption can be influenced by tire size.

Check the tire inflation pressure regularly

Check and, if needed, correct the tire inflation pressure at least twice a month and before starting on a long trip.

Low tire inflation pressure increases rolling resistance and thus raises energy consumption and tire wear.

Standing air conditioning

Run advance climate control, refer to page 132, in the vehicle during charging if possible before driving off.

Heating and cooling operations are very energy intensive and substantially reduce the electric range.

Look well ahead when driving

Avoid unnecessary acceleration and braking.

By maintaining a suitable distance to the vehicle driving ahead of you.

Driving smoothly and proactively reduces energy consumption.

Longer braking procedures result in more efficient charging of the high-voltage battery via energy recovery from braking.

Use accelerator pedal for deceleration and coasting

When approaching a red light, use accelerator pedal for decelerating.

For going downhill use coasting function; for this purpose, press accelerator pedal just enough that the vehicle rolls.

Switch off any functions that are not currently needed

Functions such as the rear window defroster require a lot of energy and reduce the range, especially in city and stop-and-go traffic.

Reel off these functions if they are not needed.

The ECO PRO and ECO PRO+ driving programs support the energy-conserving use of comfort features. They automatically perform a partial or complete deactivation of these functions.

Have maintenance carried out

Have vehicles maintained regularly to achieve optimal vehicle efficiency and operating life. The maintenance should be carried out by your service center.

ECO PRO and ECO PRO+

The concept

ECO PRO and ECO PRO+ support an efficient driving style. To this end, the control of the drive is optimized for moderate acceleration, and adapted to lighting and comfort features, such as climate control output. Some vehicle functions cannot be used during activated drive mode ECO PRO and ECO PRO+.

In addition, context-sensitive instructions can be displayed that assist in driving efficiently.

At a glance

With ECO PRO and ECO PRO+ different settings are made in the respective mode.

ECO PRO

- ▷ Reduce heat output or heating cycle for exterior mirror, rear window and seat heating.

- ▷ What reduces the the cooling and heating output of the climate control system.
- ▷ The speed is limited to an adjustable maximum value between 50 mph/80 km/h and 80 mph/130 km/h. To intentionally exceed the speed limit, press the accelerator pedal all the way down.

ECO PRO+

The cooling and heating output of the climate control system are additionally deactivated on ECO PRO+ activation.

The low beams are dimmed.

The maximum speed is limited to 55 mph/90 km/h. In special situations, the speed limit can be consciously exceeded by applying the accelerator pedal.

Activate ECO PRO and ECO PRO+



Press button repeatedly until ECO PRO or ECO PRO+ is displayed in the instrument cluster.

Configuring ECO PRO

Via the Driving Dynamics Control

1. Activate ECO PRO.
2. "Configure ECO PRO"
3. Configure the program.

Via the iDrive

1. "Settings"
2. "ECO PRO mode"

Or

1. "Settings"
2. "Driving mode"
3. "Configure ECO PRO"

Configure the program.

ECO PRO Tip

- ▷ "Limit at:"

Adjust the ECO PRO speed.

- ▷ "ECO PRO speed warning":
The output is reduced once the set ECO PRO speed is reached.

Coasting

With little pressure on the accelerator pedal, the vehicle can coast without energy recovery. The accelerator pedal indicator in the instrument display is centered between CHARGE and ePOWER during coasting.

ECO PRO climate control

"ECO PRO climate control"

Climate control is set to be fuel-efficient.

By making a slight change to the set temperature, or slowly adjusting the rate of heating or cooling of the car's interior, fuel consumption can be economized.

ECO PRO potential

Shows potential savings with the current settings in percentages.

Display in the instrument cluster

Driving style



A bar display in the instrument cluster indicates your current driving efficiency.

Mark in the CHARGE range, arrow 1: indication for energy recovery and braking.

Mark in the ePOWER area, arrow 2: display when accelerating.

Your driving style's efficiency is shown by the bar's color:

- ▷ Blue display: efficient driving style as long as the mark moves within the blue range.
- ▷ Gray display: adjust driving style, e. g., by reduced acceleration.

The display switches to blue as soon as all conditions for fuel-efficiency-optimized driving are met.



ECO PRO Tip

Driving tip

As soon as one of the conditions for efficient driving is no longer fulfilled, respective driving instructions are displayed as a symbol in the instrument cluster.

Symbols

An additional symbol and a text message are displayed on the control display.

Symbol	Measure
	For efficient driving back off the accelerator or delay accelerating to allow time to assess road conditions.
	Reduce speed to the selected ECO PRO speed.

Indications on the Control Display

eDRIVE

Information on fuel consumption and technology can be displayed while driving.

1. "Vehicle info"
2. "eDRIVE"

Displaying ECO PRO Tips

ECO PRO Tips can be displayed as a note in the split screen while driving in the energy flow display.

Displaying ECO PRO Tips:

1. "Vehicle info"
2. "eDRIVE"
3. ⓘ "ECO PRO Tips"

Settings are stored for the profile currently in use.

ECO PRO driving style analysis

The concept

The system helps develop a particularly efficient driving style and to save energy.

For this purpose, the driving style is analyzed. The assessment is done in various categories and is displayed on the Control Display.

Those assessments will help you adjust your driving style and save some energy.

The last fifteen minutes of a trip are evaluated.

The range of the vehicle can be extended by an efficient driving style.

Functional requirement

The function is only available in ECO PRO mode.

Calling up ECO PRO driving style analysis

1. Activate ECO PRO.
2. "eDRIVE"
3. //|| Select the symbol.

Display on the Control Display

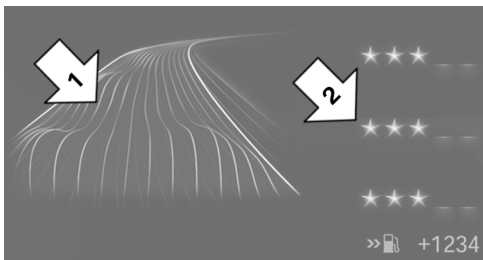

The display of the ECO PRO driving style analysis consists of a symbolized route and a lookup table.

The road symbolizes the efficiency of the driving style. The more efficient the driving style, the smoother the depicted route becomes, arrow 1.

The table of values contains stars. The more efficient the driving style, the more stars are displayed in the table, arrow 2.

If, on the other hand, the driving style is inefficient, a wavy road and a reduced number of stars is displayed.

To assist with an efficient driving style, ECO PRO tips are displayed during driving.

Tips about the energy saving driving style, Increase range, refer to page 150.



Mobility

In order to always ensure your mobility, you will find important information on operating fluids, wheels and tires, maintenance and Roadside Assistance in the following.

Charging vehicle

Vehicle features and options

This chapter describes all standard, country-specific and optional features offered with the series. It also describes features that are not necessarily available in your car, e. g., due to the selected options or country versions. This also applies to safety-related functions and systems.

The concept

The vehicle can be charged using various charging cables at charging stations or household sockets. Control and monitoring of the charging process are handled completely automatically. The charge current strength can be set by means of the Control Display.

General information

High-voltage battery

The high-voltage battery is used as an energy accumulator. The high-voltage battery can be charged by energy recovery during the trip or via the power grid.

When charging via the power grid, you can choose between the following variants.

- ▶ Level 1 charging via a household socket.
- ▶ Level 2 charging via a Level 2 charging station.
- ▶ Charging via a DC charging station.

Level 1 charging is possible via a household socket within a voltage range of 100 volts to 240 volts.

For optimal use of the energy from the power grid, charging at a Level 2 charging station, such as BMW i Wallbox, is recommended.

Charge current

The charge current strength is indicated in amperes.

The vehicle cannot automatically detect the maximum permissible charge current strength during charging via a household socket or charging station.

Level 1 charging

Prior to the first Level 1 charging at your own household socket, as well as when charging at external electrical power sockets in Level 1, the allowed charge current strength must be determined, e.g. by a qualified electrician.

The charge current strength for Level 1 charging, refer to page 161, can be adjusted in the vehicle in three steps.

At delivery, the charge current for Level 1 charging is set to "Low".

Depending on the country-specific version, one of four ampere ratings is printed on the Level 1 charging cable. This ampere rating is the limit which must be adhered to for the vehicle if the charge current is set to "Maximum". According to the market-specific version, the charge current strength changes differently if the setting "Reduced" or "Low" is selected.

"Maximum"	"Reduced"	"Low"
8 A	6 A	6 A
10 A	7.5 A	6 A
12 A	9 A	6 A
15 A	11.25 A	7.5 A

Charging at a Level 2 charging station

The permitted charge current strength must be determined prior to charging at a Level 2 charging station, e.g. from the operator

of the Level 2 charging station. The permitted charge current strength can vary by country.

The charge current strength for Level 2 charging, refer to page 162, can be adjusted in the vehicle in two steps.

At delivery, the charge current for Level 2 charging is set to "Reduced". This setting should be maintained, unless it was verified that a higher charge current strength is permitted in the individual case.

The charge current changes depending on the setting.

"Maximum"	"Reduced"
32 A	20 A

Depending on the charge current, the charging duration changes.

Range Extender

With Range Extender, refer to page 67, switched on, the current charging state can be maintained. In this way, a higher range is achieved.

Hints

 Working with electrical current
When working with electrical current, observe the safety regulations. Otherwise, with high voltage or excess current there is a risk to persons and property, e.g., from electrocution or fire. ◀

 Have the charging device checked before commissioning

Before the initial charging process, have your own charging device checked at the charging location by a qualified electrician, that is, charging port on the vehicle, charging cable, charging station or household socket and connected circuits. Otherwise, there is a danger of damage to the vehicle and overloading of the supply mains at the charging location. ◀

 Follow instructions at the charging station

When working with electrical current, follow the instructions at the charging station. Otherwise, there is a risk of an accident. ◀

 Make sure that the charging device is in flawless operating condition

Only use the charging device in a flawless condition. Otherwise, a risk of fire may result, e.g., from the device heating up because of, say, worn contacts or damage. ◀

 No simultaneous charging and refueling

Do not refuel while a charging cable is plugged in, and maintain an adequate safety distance from highly flammable materials. Otherwise, there is a danger of personal injury and property damage from burning fuel vapors, e.g., if the charging cable is improperly plugged in or unplugged. ◀

 Have the charging port cleaned by trained personnel

If the charging port is dirty, have the car cleaned only by appropriately trained personnel. Otherwise, there is a danger of injury from high voltage. ◀

Charging cable

General information

Use a Level 1 charging cable, Level 2 charging cable or the permanently installed charging cable of a charging station to charge the vehicle.

Different charging cables can be required depending on the country.

Level 1 charging cable

With the Level 1 charging cable, it is permissible to perform charging from grounded household sockets. At the power connection of a household socket, charging is done with alternating current.

When a Level 1 charging cable is used, this may produce efficiency values other than indicated on the energy label.

Level 2 charging cable

The Level 2 charging cable makes it possible to recharge at sockets of designated Level 2 charging stations using a special plug. Charging is performed with alternating current at designated Level 2 charging stations. The charging process can be completed faster than at household sockets.

If necessary, the charging cable is attached to the charging station.

If a Level 2 charging cable is used, apply the corresponding setting on the Control Display, refer to page 162.

DC charging cable

The DC charging cable that is permanently installed at the charging station makes it possible to charge at DC charging stations. Charging is performed with direct current at designated DC charging stations. At the higher lidacity current connection of a DC charger station the charging time is significantly lower than with a household socket or a level 2 charging station.

During charging at a DC charging station, an indication in the instrument cluster, refer to page 162, is displayed.

Hints



Use approved charging cables only
Use only approved charging cables or charging stations for charging. Otherwise, there is a danger of property damage or personal injury, e.g., from burning cables. Information about the approved charging cables can be obtained from the service center. ◀



Use the charging cable only for charging the vehicle, and do not extend it

Use the charging cable only for charging the vehicle and do not extend it with cables or adapters. Otherwise, it may not be possible to complete the charging process or property damage might occur, e.g., due to a cable fire. ◀



Do not use any damaged charging cables
Do not use any damaged charging cables. Otherwise, there is a risk of injury from high voltage. ◀

Storage

The Level 1 charging cable is located in the cable compartment under the hood.

The Level 2 charging cable can be stored in the same place.

Moisture can penetrate into the occasional use cable compartment, e.g. in a car wash.

If required, store the charging cable with the installed plug cover to prevent moisture in the charging cable plug.

Connection

To connect, engage lever in position P P. Set the parking brake if needed.

1. Tap on the charging port flap, arrow.



2. Remove the charging port lid, arrow.

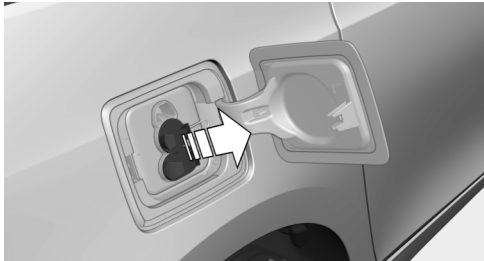

3. Connect either a Level 1 or Level 2 charging cable to the household socket or the port on the charging station.
4. Remove cover of the charging cable plug if needed.
5. Insert the charging cable plug corresponding to the charging port, and push it in until it latches.

When charging at a charging station, follow the instructions at the charging station.

Remove

When the vehicle is locked, the charging cable is locked. Unlock the vehicle before removing the cable.

1. Unlock the vehicle by remote control if it is locked.

Charging cable is unlocked.

2. Press the release button on the handle, arrow 1, and grasp the charging cable at the gripping areas.

Charging process is interrupted.

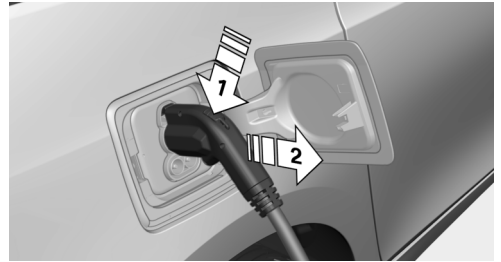

3. Remove the charging cable from the charging port, arrow 2.
4. Put the charging port lid back on.
5. Close the charging port flap.
6. Attach cover of the charging cable plug if needed.
7. Disconnect either a Level 1 or Level 2 charging cable from the household socket or the port on the charging station.
8. Stow the charging cable.

At a charging station, insert the permanently installed charging cable in the place provided for it.

Manual release

The charging port flap is automatically locked while driving.

The charging cable may be locked during the charging process.

The charging cable may be locked during the charging process if the vehicle is locked.

Manually unlocking charging port flap

In case of an electrical malfunction of the charging cable lock, the charging port flap can be manually unlocked.

1. Open rear door on the side of the charging port flap.
2. Remove the cover.
3.  Pull the blue knob, arrow. This releases the charging port flap.

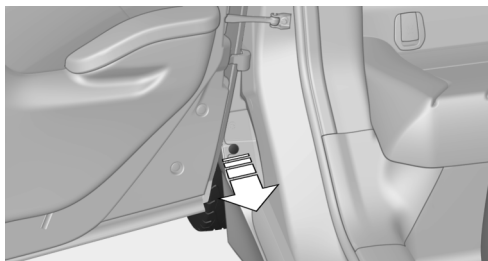

4. If necessary, press the knob back into the initial position.

Manual unlocking of the charging cable

In case of an electrical malfunction, the charging cable can be manually unlocked.

When charging at a charging station, complete the charging process at the charging station before unlocking the charging cable.

1. Open rear door on the side of the charging port flap.
2. Remove the cover.
3.  Pull the blue knob, arrow. Charging cable is manually unlocked.

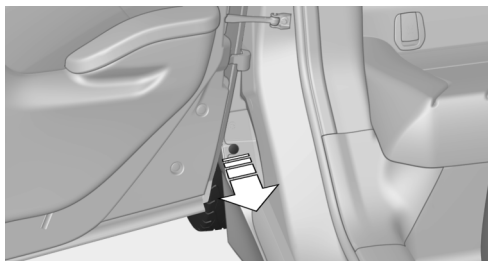

4. Grasp the charging cable at the gripping areas.
5. Remove charging cable.

Charging operation

Hints

 Following safety instructions of the power mains connection

During the charging process, heed the safety instructions of the respective power mains connection. Otherwise, there could be a risk of personal injury or property damage from high voltage, e.g., from electrocution or fire. ◀

 Using a Level 1 charging cable at other household sockets

Before charging at other household sockets, adapt the charging current strength to the mains. Otherwise, there is a risk of fire, e.g., from overheating of the household socket or overloading of the power mains. ◀

Starting charging process

1. Engage selector lever position P. Set the parking brake if needed.
2. Planning charging process, refer to page 161.
3. Switch off drive readiness.
4. Connect either a Level 1 or Level 2 charging cable to the household socket or the port on the charging station.
5. Open charging port flap.
6. Connect charging cable to the vehicle, refer to page 159.

At high temperatures, initially the high-voltage battery is cooled. The charging process can be started with a delay.

Display of the charging status

The charging status is indicated by the indicator light at the charging port.

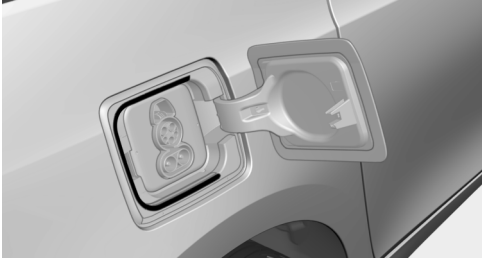

- ▷ Lamp white: charging cable can be connected or removed.
- ▷ Lamp flashes yellow: charging process is being initialized
- ▷ Lamp blue: charging process is started at set time.
- ▷ Lamp flashes blue: charging process active.
- ▷ Lamp flashes red: fault in the charging process.
- ▷ Lamp green: charging process completed.

When the vehicle is locked, the indicator lamp goes out after some time.

When the vehicle is unlocked, the blue indicator lamp flashes continuously. The other indicator lights go out after some time.

To check the charging process, press the  key on the remote control. The charging status is indicated on the indicator lamp. In some cases the vehicle is locked.

Additional messages regarding the charging status, e.g., probable end of charging or the planned departure time, can be displayed in the instrument cluster, on the Control Display and via the BMW i Remote App on the smartphone.

Planning charging process

The charging process can be adapted to constraints, e.g., the cost of electricity. The vehicle can control the charging process in such a way that the charging process is completed at the departure time. A departure time must be set for this purpose, refer to page 163.

The following settings are available:

- ▷ Charge immediately.
- ▷ Set time window for favorable charging.
- ▷ Set charging via a Level 1 charging cable.
- ▷ Set charging via a Level 2 charging cable.

If drive readiness is switched off, changes can be made on the Control Display. Departure time can only be changed once. Scheduled departure times are not adjusted. Settings for standing air conditioning and loading process are accepted for planned departure times too.

Charging immediately

The charging process starts as soon as the charging cable is connected.

1. "Settings"
2. "Charging"
3. "Charge immediately"

Setting time window for favorable charging

Level 1 or Level 2 charging:

When departure time is set, a time window for charging with a favorable electricity rate can be set.

1. "Settings"
2. "Charging"
3. "Low cost charging"
4. Set rate begin. Turn the controller until the desired time is set and press the controller.
5. Set rate end. Turn the controller until the desired time is set and press the controller.

Setting charging via a Level 1 charging cable

Depending on the electrical mains, the vehicle must be charged with a different charging current strength, refer to page 156.

1. "Settings"
2. "Charging"

3. "AC charging power:"

Settings are stored. When you change charging locations you also might need to change the setting for charging.

Set the charge current strength at other household sockets to "Low".

Setting charging via a Level 2 charging cable

Depending on the electrical mains, the vehicle must be charged with a different charging current strength, refer to page 156.

When charging with a Level 2 charging cable, the charging process can be completed faster at a Level 2 charging station.

1. "Settings"
2. "Charging"
3. "Level 2:"

Settings are stored. When you change charging locations you also might need to change the setting for charging.

Stopping charging process

The charging operation can be stopped at any time by removing the charging cable and continued at a later time by connecting the charging cable in order to use other loads on the power connection or to prevent simultaneous high power from multiple loads.

The charging operation is interrupted when the vehicle is unlocked and automatically resumed after a brief time or when it is locked.

Continue charging operation

If the charging operation is interrupted, e.g., through a temporary power failure, the charging operation is automatically continued after the interruption.









Terminating charging process





1. Removing the charging cable from the vehicle, refer to page 159.
2. Stow the charging cable as required.
3. Close the charging port flap.
4. Lock vehicle if it is unlocked.

Displays in the instrument cluster

The charging state indicator light shows the charging state of the high-voltage battery in the instrument cluster, if operating readiness is turned on. If all segments are filled, the high-voltage battery is fully charged.

Even if no segments are filled, the high-voltage system is still under high voltage.

Display	Meaning
	Plug blue: charging operation active. White plug: charging interruption.
	Running light: animated with active charging operation.
	End of charging time or set departure time.
	Charging progress bar.
	DC charging active on a DC charging station.
	Indicator in blue: charged electrical range.
	Indicator in white: maximum electrical range.
	Departure time set.

Display	Meaning
	Climate control activated at departure time.
	Range with Range Extender.
	Flashing: ventilation active.
	Flashing: heating active.
	Flashing: cooling active.

Departure time

The concept

For optimum range and climate control, the departure time can be set before parking the car.

With a set departure time, the vehicle is climate controlled during the charging process when climate control is set. Climate control output is reduced during the trip. This increases the range.

The following settings are possible at departure time:

- ▷ Climate control at departure time.
- ▷ Planning a one-time departure time.
- ▷ Planning of up to three regular departure times per day of the week.

If drive readiness is switched off, changes can be made on the Control Display. Departure time can only be changed once. Scheduled departure times are not adjusted. Settings for climate control and charging operation are also applied for scheduled departure times.

Climate control at departure time

1. "Settings"
2. "Departure time"
3. "Precond. for departure"

Setting departure time

Level 1 or Level 2 charging:

1. "Settings"
2. "Departure time"
3. "Departure 1:"
4. Set the day of the week if needed.

Turn the controller until the desired day of the week is set and press the controller.

To select other days of the week, repeat the operation.

5. Set the time.

Turn the controller until the desired time is set and press the controller.

Up to three departure times can be set.

Activating the departure time

1. "Settings"
2. "Departure time"
Set departure times are displayed.
3. E. g. "Activate depart. time 1"

Up to three departure times can be activated.

The set departure time will be deactivated, if the departure time was ignored three times in a row.

Climate control

General information

The following settings for climate control of the vehicle are possible:

- ▷ Activate stationary climate control immediately, refer to page 132.

With stationary climate control activated and no charging cable connected, the range is reduced.

- ▶ Planned climate control at the set departure time, refer to page 133.

Discharged high-voltage and vehicle battery

General information

In addition to the high-voltage battery, the vehicle has a 12 volt vehicle battery, which is required for operation of the onboard electronics.

If the high-voltage battery and the vehicle battery are discharged, it is not possible to operate the vehicle.

Place vehicle in service

To place the vehicle in service, charge as usual.

If there is no possibility of charging on site, contact the service center.

Charging vehicle with a discharged vehicle battery

1. Unlock the vehicle, if needed, using the integrated key, refer to page 36.
2. Secure the vehicle against rolling.
3. Manually unlock charging port flap if it is locked, refer to page 159.
4. Connect either a Level 1 or Level 2 charging cable to the household socket or the port on the charging station.
5. Attach charging cable corresponding to the charging socket connection.

Charging is started. The charging status is not displayed. Do not open vehicle during this time.

After several minutes, the vehicle is slightly charged. The onboard electronics are ready again. It is again possible to open the vehicle.

The charging status as well as the charging state of the high-voltage battery can be displayed again.

Continue charging vehicle until desired range is possible.

If the vehicle battery cannot be charged, contact the service center.

Refueling

Vehicle features and options

This chapter describes all standard, country-specific and optional features offered with the series. It also describes features that are not necessarily available in your car, e. g., due to the selected options or country versions. This also applies to safety-related functions and systems.

Hints

A sufficient amount of fuel must be added to operate the Range Extender. When the Range Extender is activated, the current charging state is maintained. The vehicle has a greater range.

 Do not refuel unless the engine is at a standstill and the selector lever is in position P/N

Do not refuel unless the engine is at a standstill and the selector lever is in position P/N, otherwise the buildup of pressure may cause the fuel nozzle to shut off prematurely. ◀

Tank vent

The concept

The vehicle is equipped with a special fuel tank. It is designed for special requirements that arise in operation with the Range Extender.

General information

In the fuel tank, excess pressure can build up due to gasoline vapors which are dissipated before the tank lid is opened.

At a glance

The button is located on the driver's footwell.

Tank venting

1. Switch off drive readiness.



2. Press button to start the pressure equalization.

The status of the tank venting is displayed in the instrument cluster. In rare cases, the tank venting can last several seconds.

If the tank venting has been completed, a message is displayed in the instrument cluster. The tank lid is released for opening.

3. Open the fuel filler flap.

If the fuel filler flap is not opened within 10 minutes after the fuel filler flap was released, the fuel filler flap relocks. Press button again.

Fuel lid

Opening

Before opening, vent the tank, refer to page 165.

1. Briefly press the rear edge of the fuel filler flap.



2. Turn the tank lid counterclockwise.

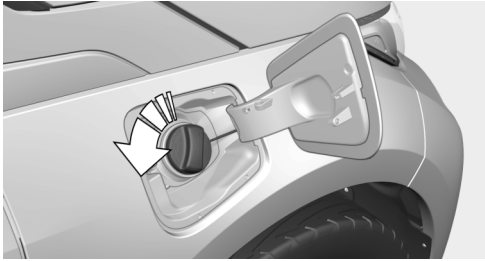

3. Place the tank lid in the bracket attached to the fuel filler flap.

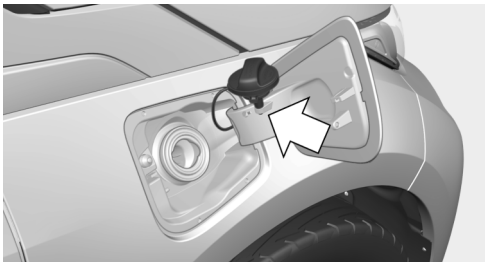

Closing

1. Fit the lid and turn it clockwise until you clearly hear a click.
2. Close the fuel filler flap.

 Do not pinch the retaining strap
Do not pinch the retaining strap attached to the lid; otherwise, the lid cannot be closed properly and fuel vapors can escape. ◀

Manually unlocking fuel filler flap

In the event of an electrical malfunction, e.g.

The release is located in the cargo area.

1. Open hood, refer to page 180.
2. Pull the green knob with the fuel pump symbol. This releases the fuel filler flap.

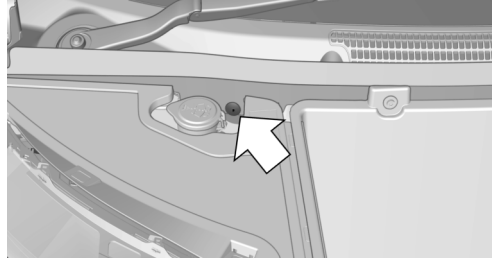

3. Open the fuel filler flap.
4. Carefully open the fuel filler flap. Excess pressure can build up in the fuel tank from gasoline vapor.

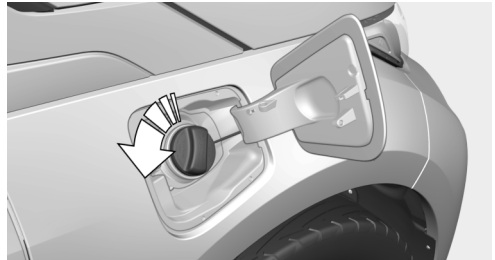

5. Fuel the vehicle as usual. This may be difficult due to the residue pressure in the tank, caused by frequent stopping of the fuel pump nozzle, e.g.

Observe the following when refueling

The fuel tank is full when the filler nozzle clicks off the first time.

 Do not overfill the fuel tank
Do not overfill the fuel tank; otherwise fuel may eslide, causing harm to the environment and damaging the vehicle. ◀



Handling fuels

Observe safety regulations posted at the gas station. ◀



No simultaneous charging and refueling

Do not refuel while a charging cable is plugged in, and maintain an adequate safety distance from highly flammable materials. Otherwise, there is a danger of personal injury and property damage from burning fuel vapors, e.g., if the charging cable is improperly plugged in or unplugged. ◀

Fuel

Vehicle features and options

This chapter describes all standard, country-specific and optional features offered with the series. It also describes features that are not necessarily available in your car, e. g., due to the selected options or country versions. This also applies to safety-related functions and systems.

Fuel recommendation

Note

 General fuel quality
 Even fuels that conform to the specifications can be of low quality. This may cause engine problems, for instance poor engine start-up behavior, poor handling and/or poor performance. Switch gas stations or use a brand name fuel with a higher octane rating. ◀

Gasoline

For the best fuel efficiency, the gasoline should be sulfur-free or very low in sulfur content.

Fuels that are marked on the gas pump as containing metal must not be used.

 Refuel only with unleaded gasoline without metallic additives.

Do not refuel with any leaded gasoline or gasoline with metallic additives, e. g. manganese or iron, as this can cause permanent damage to the catalytic converter and other components. ◀

Fuels with a maximum ethanol content of 10 %, i. e., E10, may be used for refueling.

Ethanol should satisfy the following quality standards:

US: ASTM 4806–xx

CAN: CGSB-3.511–xx

xx: comply with the current standard in each case.

 Do not use a fuel with a higher percentage of ethanol

Do not use a fuel with a higher ethanol percentage than recommended or one with other types of alcohol, e.g. M5 to M100; otherwise this could damage the engine and fuel supply system. ◀

Recommended fuel grade

BMW recommends AKI 91.

Minimum fuel grade

BMW recommends AKI 89.

 Minimum fuel grade
 Do not use any gasoline below the minimum fuel grade as this may impair engine performance. ◀

Fuel supply in winter

Depending on the region, many gas stations sell fuel that has been customized to winter or summer conditions.

Fuel that is available in winter helps make a cold start easier, e. g.

The manufacturer of the vehicle recommends filling the tank with the corresponding fuel at the start of winter to ensure the operational reliability of the Range Extender at low temperatures.

BMW recommends BP fuels 

Wheels and tires

Vehicle features and options

This chapter describes all standard, country-specific and optional features offered with the series. It also describes features that are not necessarily available in your car, e. g., due to the selected options or country versions. This also applies to safety-related functions and systems.

Tire inflation pressure

Safety information

The tire characteristics and tire inflation pressure influence the following:

- ▷ The service life of the tires.
- ▷ Road safety.
- ▷ Driving comfort.

Checking the tire inflation pressure



Check the tire inflation pressure regularly

Regularly check the tire inflation pressure, and correct it as needed: at least twice a month and before a long trip. If you fail to observe this precaution, you may be driving on tires with incorrect tire pressures, a condition that may not only compromise your vehicle's driving stability, but also lead to tire damage and the risk of an accident. ◀

Tires have a natural, consistent loss of tire inflation pressure.

Tires heat up while driving, and the tire inflation pressure increases along with the tire's temperature. The tire inflation pressure specifications relate to cold tires or tires with the ambient temperature.

Only check the tire inflation pressure when the tires are cold. This means after driving no more

than 1.25 miles/2 km or when the vehicle has been parked for at least 2 hours.

The displays of inflation devices may under-read by up to 1.45 psi/0.1 bar.

For Flat Tire Monitor: after correcting the tire inflation pressure, reinitialize the Flat Tire Monitor.

For Tire Pressure Monitor: after correcting the tire inflation pressure, reset the Tire Pressure Monitor.

Tire inflation pressure specifications

The tire inflation pressure table, refer to page 171, contains all tire inflation pressure specifications for the specified tire sizes at the ambient temperature. Tire inflation pressure specifications apply to approved tire sizes and recommended tire brands. This information can be obtained from your service center.

To identify the correct tire inflation pressure, please note the following:

- ▷ Tire sizes of your vehicle.

Tire fill pressures

To achieve optimum driving comfort, note the pressure specifications in the Tire inflation pressure table, refer to page 171, and adjust as needed.

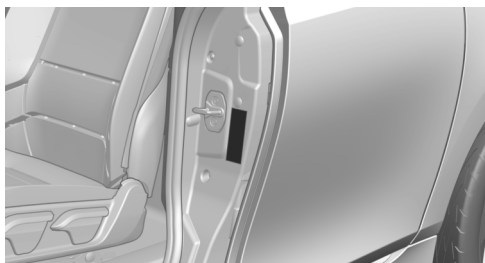

These pressure values can also be found on the tire inflation pressure label on the driver's side on the rear door.



Maximum permissible speed

Do not exceed 100 mph/160 km/h; otherwise, tire damage and accidents may result. ◀

Tire inflation pressure values

i3

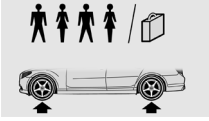
Tire size	Pressure specifications in bar/PSI	
Specifications in bar/PSI with cold tires		
155/70 R 19 84 Q M+S A/S Std	2.3 / 33	2.8 / 41
155/70 R 19 84 Q M+S Std		
Front: 155/70 R 19 84 Q M+S A/S Std	2.3 / 33	-
Rear: 175/60 R 19 86 Q M+S A/S Std	-	2.8 / 41
Front: 155/60 R 20 80 Q Std	2.3 / 33	-
Rear: 175/55 R 20 85 Q Std	-	2.8 / 41

Tire identification marks

Tire size

245/45 R 18 96 Y

245: nominal width in mm

45: aspect ratio in %

R: radial tire code

18: rim diameter in inches

96: load rating, not for ZR tires

Y: speed rating, before the R on ZR tires

Speed letter

Q = up to 100 mph, 160 km/h

R = up to 106 mph, 170 km/h

S = up to 112 mph, 180 km/h

T = up to 118 mph, 190 km/h

H = up to 131 mph, 210 km/h

V = up to 150 mph, 240 km/h

W = up to 167 mph, 270 km/h

Y = up to 186 mph, 300 km/h

Tire Identification Number

DOT code: DOT xxxx xxx 4314

xxxx: manufacturer code for the tire brand

xxx: tire size and tire design

4314: tire age

Tires with DOT codes meet the guidelines of the U.S. Department of Transportation.

Tire age

DOT ... 4314: the tire was manufactured in the 43th week of 2014.

Recommendation

Regardless of wear and tear, replace tires at least every 6 years.

Uniform Tire Quality Grading

Quality grades can be found where applicable on the tire sidewall between tread shoulder and maximum section width.

For example: Treadwear 200; Traction AA; Temperature A

DOT Quality Grades

Treadwear

Traction AA A B C

Temperature A B C

All passenger car tires must conform to Federal Safety Requirements in addition to these grades.

Treadwear

The treadwear grade is a comparative rating based on the wear rate of the tire when tested under controlled conditions on a specified government test course. For example, a tire graded 150 would wear one and one-half, 1 g, times as well on the government course as a tire graded 100. The relative performance of tires depends upon the actual conditions of their use, however, and may depart significantly from the norm due to variations in driving habits, service practices and differences in road characteristics and climate.

Traction

The traction grades, from highest to lowest, are AA, A, B, and C.

Those grades represent the tire's ability to stop on wet pavement as measured under controlled conditions on specified government test surfaces of asphalt and concrete. A tire marked C may have poor traction performance.

The traction grade assigned to this tire is based on straight-ahead braking traction tests, and does not include acceleration, cornering, hydroplaning, or peak traction characteristics.

Temperature

The temperature grades are A, the highest, B, and C, representing the tire's resistance to the generation of heat and its ability to dissipate heat when tested under controlled conditions on a specified indoor laboratory test wheel. Sustained high temperature can cause the material of the tire to degenerate and reduce tire life, and excessive temperature can lead to sudden tire failure. The grade C corresponds to a level of performance which all passenger car tires must meet under the Federal Motor Vehicle Safety Standard No. 109. Grades Band A represent higher levels of performance on the laboratory test wheel than the minimum required by law.



Temperature grade for this tire

The temperature grade for this tire is established for a tire that is properly inflated and not overloaded. Excessive speed, underinflation, or excessive loading, either separately or in combination, can cause heat buildup and possible tire failure.

If necessary, have the vehicle towed. ◀

M+S

Winter and all-season tires with better cold weather performance than summer tires.

Tire tread

Summer tires

Do not drive with a tire tread depth of less than 0.12 in/3 mm.

There is an increased danger of hydroplaning if the tire tread depth is less than 0.12 in/3 mm.

Winter tires

Do not drive with a tire tread depth of less than 0.16 in/4 mm.

Below a tread depth of 0.16 in/4 mm, tires are less suitable for winter operation.

Minimum tread depth



Wear indicators are distributed around the tire's circumference and have the legally required minimum height of 0.063 in/1.6 mm.

They are marked on the side of the tire with TWI, Tread Wear Indicator.

Tire damage

General information

Inspect your tires often for damage, foreign objects lodged in the tread, and tread wear.

Hints

Driving over rough or damaged road surfaces, as well as debris, curbs and other obstacles can cause serious damage to wheels, tires and suspension parts. This is more likely to occur with low-profile tires, which provide less cushioning between the wheel and the road. Be careful to avoid road hazards and reduce your speed, especially if your vehicle is equipped with low-profile tires.

Indications of tire damage or other vehicle defects:

- ▷ Unusual vibrations while driving.
- ▷ Unusual handling such as a strong tendency to pull to the left or right.

Damage can, e. g., be caused by driving over curbs, road damage, or similar things.

In case of tire damage

If there are indications of tire damage, reduce your speed immediately and have the rims and tires checked right away; otherwise, there is the increased risk of an accident.

Drive carefully to the nearest service center. Have the vehicle towed or transported there. Otherwise, tire damage can become life threatening for vehicle occupants and also other traffic. ◀

Repair of tire damage

For safety reasons, the manufacturer of your vehicle recommends that you do not have damaged tires repaired; they should be replaced. Otherwise, damage can occur as a result. ◀

Changing wheels and tires

Mounting



Information on mounting tires

Have mounting and balancing performed only by a service center.

If work is not carried out properly, there is a danger of subsequent damage and related safety hazards. ◀

Wheel and tire combination

You can ask the service center about the right wheel/tire combination and wheel rim versions for the vehicle.

Incorrect wheel and tire combinations impair the function of a variety of systems such as ABS or DSC.

To maintain good handling and vehicle response, use only tires with a single tread configuration from a single manufacturer.

Following tire damage, have the original wheel and tire combination remounted on the vehicle as soon as possible.



Approved wheels and tires

You should only use wheels and tires that have been approved by the vehicle manufacturer for your vehicle type; otherwise, e.g., despite having the same official size ratings, variations can lead to chassis contact and with it, the risk of severe accidents

The manufacturer of your vehicle cannot evaluate non-approved wheels and tires to determine if they are suited for use, and therefore cannot guarantee the operating safety of the vehicle. ◀

Recommended tire brands



For each tire size, the manufacturer of your vehicle recommends certain tire brands. These can be identified by a star on the tire sidewall. With proper use, these tires meet the highest standards for safety and handling.

New tires

Tire traction is not optimal due to manufacturing circumstances when tires are brand-new; they achieve their full traction potential after a break-in time.

Drive conservatively for the first 200 miles/300 km.

Retreaded tires

The manufacturer of your vehicle does not recommend the use of retreaded tires.



Retreaded tires

Possibly substantial variations in the design and age of the tire casing structures can limit service life and have a negative impact on road safety. ◀

Winter tires

Winter tires are recommended for operating on winter roads.

Although so-called all-season M+S tires provide better winter traction than summer tires, they do not provide the same level of performance as winter tires.

Maximum speed of winter tires

If the maximum speed of the vehicle is higher than the permissible speed for the winter tires, then a respective symbol is displayed in your field of vision. You can obtain this sign from the tire specialist or from your service center.



Maximum speed for winter tires

Do not exceed the maximum speed for the respective winter tires; otherwise, tire damage and accidents can occur. ◀

Rotating wheels between axles

Different wear patterns can occur on the front and rear axles depending on individual driving conditions. The tires can be rotated between the axles to achieve even wear. Your service center will be glad to advise you. After rotating, check the tire pressure and correct if needed.

Rotating the tires is not permissible on vehicles with different tire sizes on the front and rear axles, i.e. when using different types of tires.

Storage

Store wheels and tires in a cool, dry place with as little exposure to light as possible.

Always protect tires against all contact with oil, grease and fuels.

Do not exceed the maximum tire inflation pressure indicated on the side wall of the tire.

Mobility System

The concept

With the Mobility System, minor tire damage can be sealed quickly to enable continued travel. To accomplish this, sealant is pumped into the tires, which seals the damage from the inside.

The compressor can be used to check the tire inflation pressure.

Hints

- ▷ Follow the instructions on using the Mobility System found on the compressor and sealant container.
- ▷ Use of the Mobility System may be ineffective if the tire puncture measures approx. 1/8 in/4 mm or more.
- ▷ Contact the nearest service center if the tire cannot be made drivable.
- ▷ If possible, do not remove foreign bodies that have penetrated the tire.
- ▷ Pull the speed limit sticker off the sealant container and apply it to the steering wheel.
- ▷ The use of a sealant can damage the TPM wheel electronics. In this case, have the electronics checked at the next opportunity and have them replaced if needed.

Storage

The mobility system is located in the storage compartment under the hood.

Sealing container

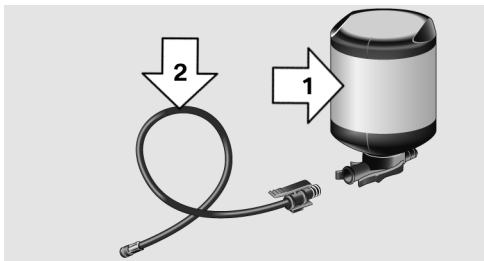

- ▷ Sealing container, arrow 1.
- ▷ Filling hose, arrow 2.

Observe use-by date on the sealant container.

Compressor

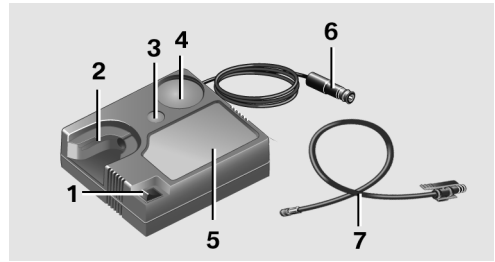

- 1 On/off reel
- 2 Holder for bottle
- 3 Reduce inflation pressure
- 4 Inflation pressure dial
- 5 Compressor
- 6 Connector/cable for socket
- 7 Connection hose — stowed in the bottom of the compressor

Filling the tire with sealant

1. Shake the sealing container.

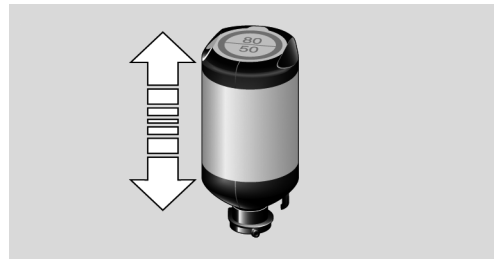

- Take the connection hose completely out of the compressor housing. Do not kink the hose.

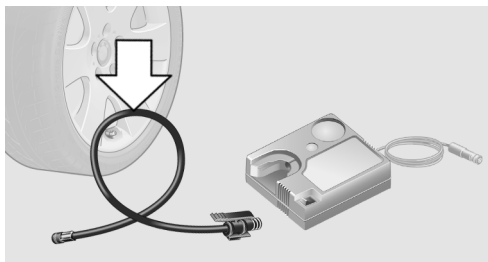

- Attach the connection hose to the connector of the sealing container, ensuring that it engages audibly.

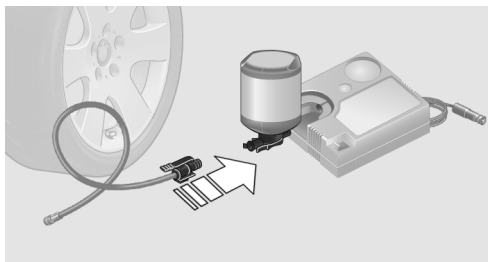

- Slide the sealing container upright into the holder on the compressor housing, ensuring that it engages audibly.

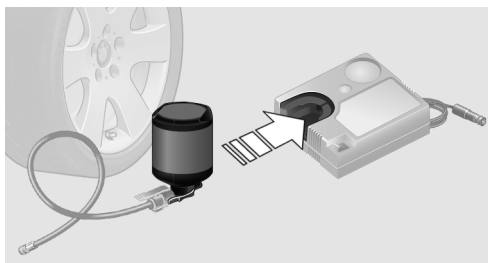

- Screw the connection hose onto the tire valve of the defective wheel.

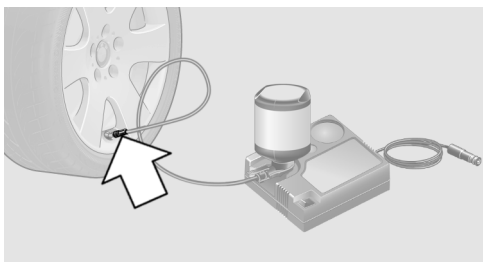

- With the compressor switched off, insert the plug into a power socket inside the vehicle.

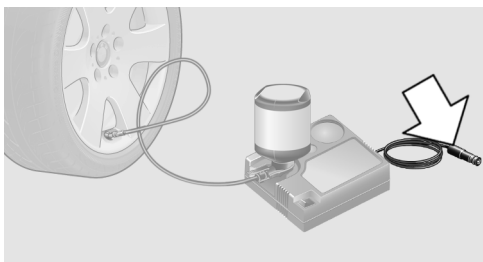

- With operating readiness or drive readiness switched on, reel on the compressor.

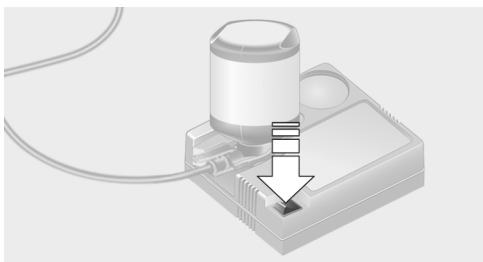

- !** Switch off the compressor after 10 minutes

Do not allow the compressor to run longer than 10 minutes; otherwise, the device will overheat and may be damaged. ◀

Let the compressor run for approx. 3 to 8 minutes to fill the tire with sealant and achieve a tire inflation pressure of approx. 2.5 bar.

While the tire is being filled with sealant, the tire inflation pressure may sporadically reach approx. 5 bar. Do not reel off the compressor at this point.

If a tire inflation pressure of 2 bar is not reached:

1. Switch off the compressor.
2. Unscrew the filling hose from the wheel.
3. Drive 33 ft/10 m forward and back to distribute the sealant in the tire.
4. Inflate the tire again using the compressor.

If a tire inflation pressure of 2 bar cannot be reached, contact your service center.

Stowing the Mobility System

1. Remove the connection hose of the sealant container from the wheel.
2. Remove the connection hose from the sealant container.
3. Wrap the empty sealant container and connection hose in suitable material to avoid dirtying the cargo area.
4. Stow the Mobility System back in the vehicle.

Distributing the sealant

Immediately drive approx. 5 miles/10 km to ensure that the sealant is evenly distributed in the tire.

Do not exceed a speed of 50 mph/80 km/h.

If possible, do not drive at speeds less than 12 mph/20 km/h.

To correct the tire inflation pressure

1. Stop at a suitable location.
2. Screw the connection hose onto the tire valve stem.

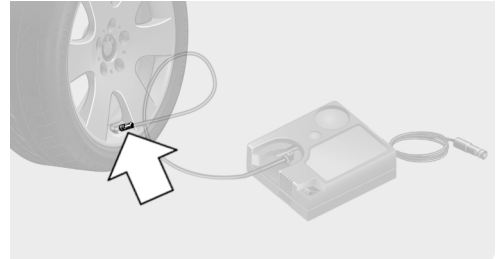

3. Attach the connection hose directly to the compressor.

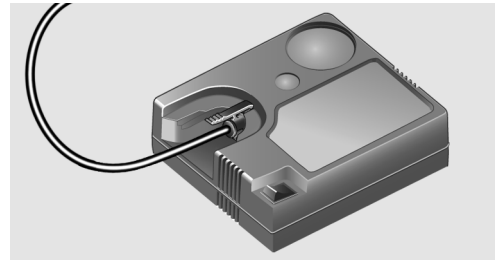

4. Insert the connector into a power socket inside the vehicle.

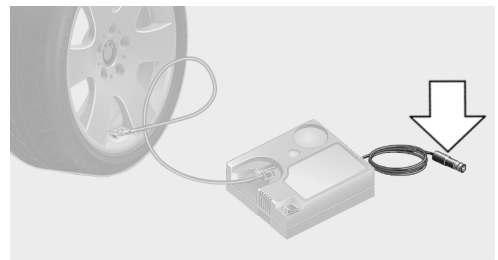

5. Correct the tire inflation pressure to 2.5 bar.
 - ▶ Increase pressure: with operating readiness or drive readiness switched on, reel on the compressor.
 - ▶ To reduce the pressure: press the button on the compressor.

Continuing the trip

Do not exceed the maximum permissible speed of 50 mph/80 km/h.

Reinitialize the Flat Tire Monitor.

Reinitialize the Tire Pressure Monitor.

Replace the defective tire and the sealant container of the Mobility System as soon as possible.

Snow chains

Fine-link snow chains

Only certain types of fine-link snow chains have been tested by the manufacturer of the vehicle, classified as road-safe and approved.

Information about the approved snow chains are available from the service center.

Use

Use only in pairs on the rear wheels, equipped with the tires of the following size:

- ▷ 155/70 R 19

Follow the snow chain manufacturer's instructions.

Make sure that the snow chains are always sufficiently tight. Retighten as needed according to the chain manufacturer's instructions.

Do not initialize the Flat Tire Monitor after mounting snow chains, as doing so may result in incorrect readings.

Do not initialize the Tire Pressure Monitor after mounting snow chains, as doing so may result in incorrect readings.

When driving with snow chains, briefly activate Dynamic Traction Control if needed.

Maximum speed with snow chains

Do not exceed a speed of 30 mph/50 km/h when using snow chains.

Under the hood

What is important under the hood

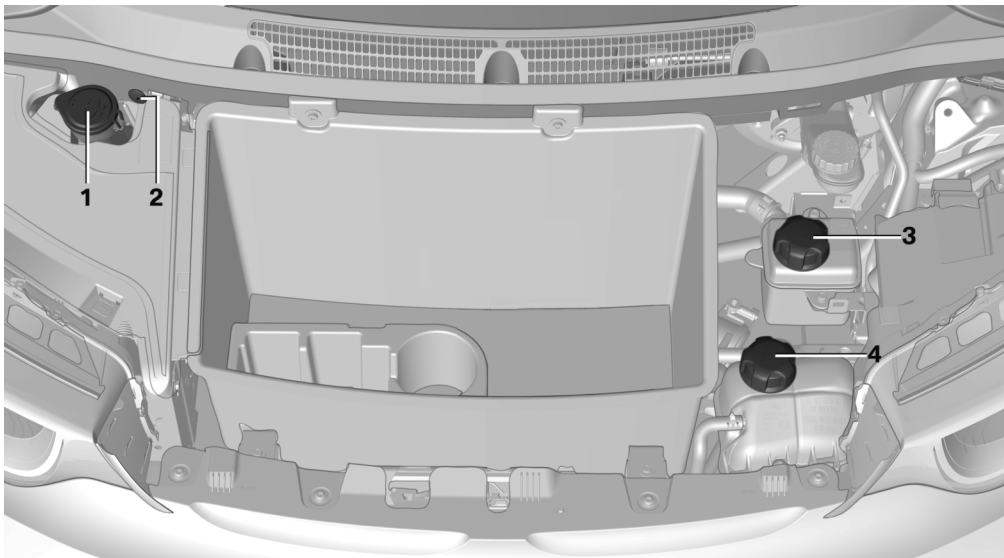

- | | |
|---|---|
| <p>1 Washer fluid reservoir</p> <p>2 With Range Extender: filler flap emergency unlocking</p> | <p>3 Coolant reservoir for climate control</p> <p>4 Coolant reservoir for drive</p> |
|---|---|

The occasional use cable compartment in the center is used for storage of the Level 1 charging cable and the Level 2 charging cable.

Moisture can penetrate into the occasional use cable compartment, e.g. in a car wash.

If you are unfamiliar with the statutory guidelines, have any work on the vehicle performed only by a service center.

If work is not carried out properly, there is a danger of subsequent damage and related safety hazards. ◀

Hood

Hints

Working under the hood

Never attempt to perform any service or repair operations on your vehicle without the necessary professional technical training.

Fold down wiper arm

Before opening the hood, ensure that the wiper arms are against the windshield, or this may result in damage. ◀

Opening hood

Unlocking hood

1.  Press button on the remote control or in the driver's footwell, refer to page 42.

Opening hood

1. Press the release handle and open the hood.

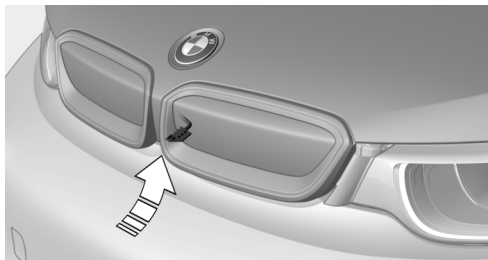

Indicator/warning lights

When the hood is opened, a Check Control message is displayed.

Closing the hood

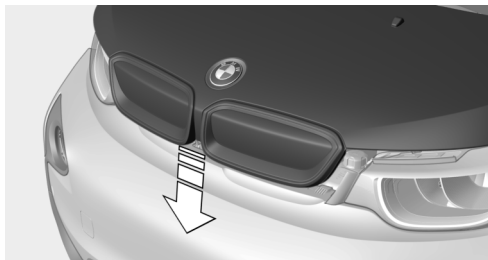

From approx. 16 in/40 cm height allow to fall and press again to lock the hook completely. Make sure you hear the hood engage.

-  **Hood open when driving**
If you see any signs that the hood is not completely closed while driving, pull over immediately and close it securely. ◀

-  **Danger of jamming**
Make sure that the closing path of the hood is clear; otherwise, injuries may result. ◀

Engine oil

Vehicle features and options

This chapter describes all standard, country-specific and optional features offered with the series. It also describes features that are not necessarily available in your car, e. g., due to the selected options or country versions. This also applies to safety-related functions and systems.

General information

Engine oil consumption depends on the frequency of Range Extender use. Therefore, regularly check the engine oil level after refueling.

Checking the oil level

Note

Check the engine oil level with Range Extender warmed up to operating temperature.

After switching off the Range Extender, wait several minutes before checking the oil level so that the engine oil can collect in the oil pan.

Checking

1. Park the vehicle in horizontal position in a safe place.
2. Switch the engine off.

3. Remove the cargo floor panel.

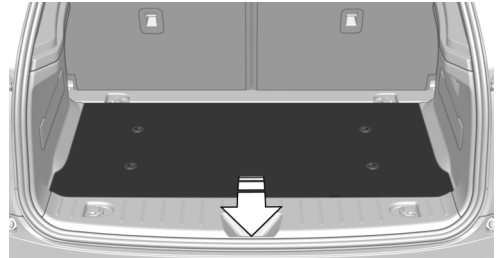

4. Turn the lid counterclockwise and remove.

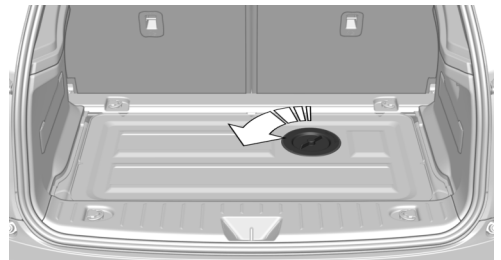

5. After approx. 5 minutes, remove the dipstick and wipe with a lint-free cloth, paper towel or similar.

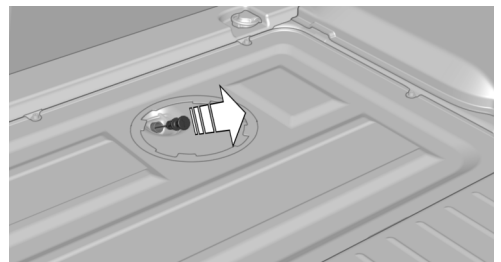

6. Carefully insert the dipstick up to the stop in the measuring tube, and pull it back out. The engine oil level must be between the two marks of the dipstick.

Adding or changing engine oil

If necessary, have engine oil added or changed by the service center.

Coolant

Vehicle features and options

This chapter describes all standard, country-specific and optional features offered with the series. It also describes features that are not necessarily available in your car, e. g., due to the selected options or country versions. This also applies to safety-related functions and systems.

Hints



Danger of burns from hot engine

Do not open the cooling system while the engine is hot; otherwise, escaping coolant may cause burns. ◀



Suitable additives

Only use suitable additives; otherwise, engine damage may occur. The additives are harmful to your health. ◀

Coolant consists of water and additives.

The vehicle's cooling circuits are filled with different types of coolant. Do not mix the different types of coolant.

Not all commercially available additives are suitable for the vehicle. Information about the suitable additives are available from the service center.

Coolant reservoir

The vehicle has two coolant reservoirs that are located under the hood.

To ensure the operational reliability of the vehicle, always check the coolant level of both coolant reservoirs.

Open hood, refer to page 180.

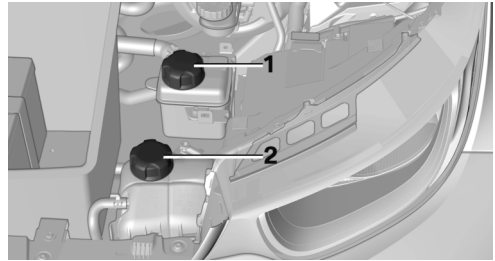

- 1 Coolant reservoir for climate control
- 2 Coolant reservoir for drive

Coolant level

Coolant reservoir for climate control

Checking

1. Allow the drive to cool down.
2. Turn the lid of the coolant reservoir slightly counterclockwise to allow any excess pressure to dissipate, then open it.

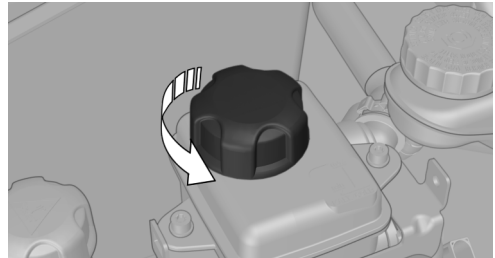

3. Check the coolant level.

The coolant level is correct if it lies between the minimum and maximum marks in the reservoir.

Adding

1. Slowly add coolant up to the specified level; do not overfill.

2. Close cap.
3. Have the cause of the coolant loss eliminated by the service center as soon as possible.

Coolant reservoir for drive

Checking

1. Allow the drive to cool down.
2. Check the coolant level.

The marks are on the side of the coolant reservoir. The coolant level is correct if it lies between the minimum and maximum marks.

Adding

1. Turn the lid of the coolant reservoir slightly counterclockwise to allow any excess pressure to dissipate, then open it.

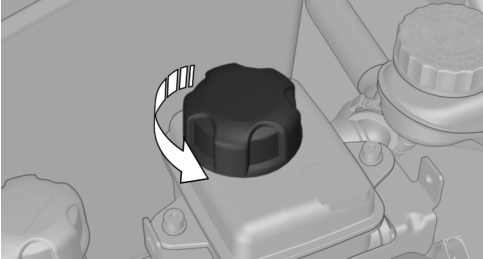

2. Slowly add coolant up to the specified level; do not overfill.
3. Close cap.
4. Have the cause of the coolant loss eliminated by the service center as soon as possible.

Disposal



Comply with the relevant environmental protection regulations when disposing of coolant and coolant additives.

Maintenance

Vehicle features and options

This chapter describes all standard, country-specific and optional features offered with the series. It also describes features that are not necessarily available in your car, e. g., due to the selected options or country versions. This also applies to safety-related functions and systems.

BMW maintenance system

The maintenance system indicates required maintenance measures, and thereby provides support in maintaining road safety and the operational reliability of the vehicle.

Note



Maintenance and repairs

Have maintenance and repair work performed only by a service center or a workshop that works according to BMW specifications with appropriately trained personnel. Otherwise, there is the risk of fatal injury from electrocution due to the high-voltage system's high voltage. ◀

Condition Based Service CBS

Sensors and special algorithms take into account the driving conditions of your vehicle. Based on this, Condition Based Service recognizes the maintenance requirements.

The system makes it possible to adapt the amount of maintenance corresponding to your user profile.

Detailed information on service requirements, refer to page 82, can be displayed on the Control Display.

For service data

Information on the required maintenance is continuously stored in the remote control. Your service center will read out this data and suggest the right array of service procedures for your vehicle.

Therefore, hand your service specialist the remote control with which the vehicle was driven most recently.

Storage periods

Storage periods during which the vehicle battery was disconnected are not taken into account.

If this occurs, have a service center update the time-dependent maintenance procedures, such as checking brake fluid and, if needed, changing the engine oil and the microfilter/activated-charcoal filter.

Service and Warranty Information Booklet for US models and Warranty and Service Guide Booklet for Canadian models

Please consult your Service and Warranty Information Booklet for US models and Warranty and Service Guide Booklet for Canadian models for additional information on service requirements.

Maintenance and repair should be performed by your service center. Make sure to have regular maintenance procedures recorded in the vehicle's Service and Warranty Information Booklet for US models, and in the Warranty

and Service Guide Booklet for Canadian models. These entries are proof of regular maintenance.

Socket for OBD Onboard Diagnosis

Note



Socket for Onboard Diagnosis

The socket for onboard diagnostics may only be used by the service center or a workshop that operates in accordance with the specifications of the vehicle manufacturer with correspondingly trained personnel and other authorized persons. Otherwise, use may result in operating problems for the vehicle. ◀

Position

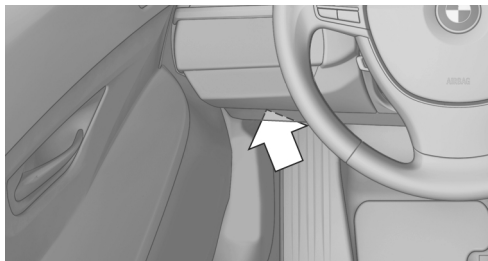

Located on the driver's side is an OBD socket for reading the vehicle data. On vehicles with Range Extender, additional components are checked that are critical for its emissions mix.

Emissions

Applies to vehicles with Range Extender.



- ▶ The warning lamp lights up: Emissions are deteriorating. Have the vehicle checked as soon as possible.
- ▶ The warning lamp flashes under certain circumstances:

This indicates that there is excessive misfiring in the engine.

Reduce the vehicle speed and have the system checked immediately; otherwise, serious engine misfiring within a brief period can seriously damage emission control components, in particular the catalytic converter.

Replacing components

Vehicle features and options

This chapter describes all standard, country-specific and optional features offered with the series. It also describes features that are not necessarily available in your car, e. g., due to the selected options or country versions. This also applies to safety-related functions and systems.

Wiper blade replacement

General information

 Do not fold down the wipers without wiper blades

Do not fold down the wipers if wiper blades have not been installed; this may damage the windshield. ◀

Front: Replacing the wiper blades

1. To change the wiper blades, fold up, refer to page 72, the wiper arms.
2. Fold up the wipers.

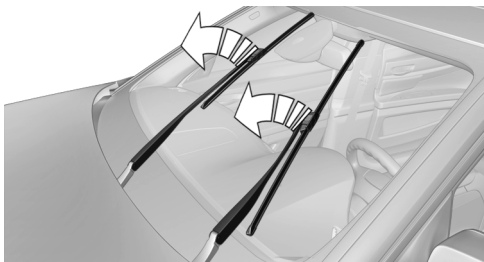

3. Position the wiper blade in a horizontal position.

4. Remove the wiper blade toward one side.



5. Insert the new wiper blade in reverse order of removal until it locks in place.
6. Fold down the wipers.

Rear: replacing the wiper blades

1. Lift off the wiper fully and pull off the wiper blade, arrow.

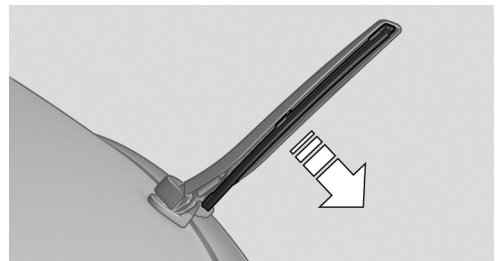

2. Attach a new wiper blade. It must engage audibly.
3. Fold down the wipers.

Lamp and bulb replacement

Hints

Lights and bulbs

Lights and bulbs make an essential contribution to vehicle safety.

The manufacturer of the vehicle recommends that you entrust corresponding procedures to

the service center if you are unfamiliar those or if they have not been described here.

You can obtain a selection of replacement bulbs at the service center.

 **Danger of burns**

Only change bulbs when they are cool; otherwise, there is a danger of getting burned. ◀

 **Working on the lighting system**

When working on the lighting system, you should always reel off the lights affected to prevent short circuits.

To avoid possible injury or equipment damage when replacing bulbs, observe any instructions provided by the bulb manufacturer. ◀

 **Do not touch the bulbs**

Do not touch the glass of new bulbs with your bare hands, as even minute amounts of contamination will burn into the bulb's surface and reduce its service life.

Use a clean tissue, cloth or something similar, or hold the bulb by its base. ◀

Light-emitting diodes (LEDs)

Some items of equipment use light-emitting diodes installed behind a cover as a light source.

These light-emitting diodes, which are related to conventional lasers, are officially designated as Class 1 light-emitting diodes.

 **Do not remove the covers**

Do not remove the covers, and never stare into the unfiltered light for several hours; otherwise, irritation of the retina could result. ◀

Headlight glass

Condensation can form on the inside of the external lights in cool or humid weather. When driving with the light switched on, the condensation evaporates after a short time. The headlight glass does not need to be changed.

If the headlights do not dim despite driving with the light switched on, increasing humidity forms, e. g. water droplets in the light, have the service center check this.

Headlight setting

The headlight adjustments can be affected by changing lights and bulbs. Have the headlights' settings checked and corrected by service after a replacement.

Front lights, bulb replacement

At a glance

Halogen headlights

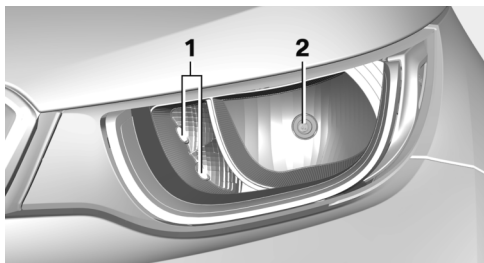

- 1 Parking lights / daytime running lights
- 2 Low beams

Halogen headlights with LED lighting elements

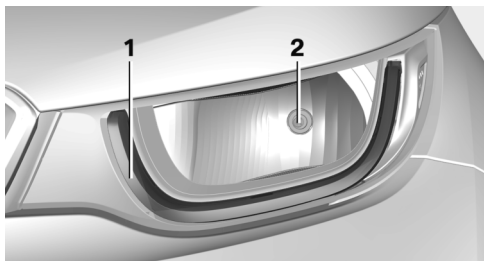

- 1 Parking lights / daytime running lights
- 2 Low beams

Low beams

Follow general instructions, refer to page 187.
55-watt bulb, H7.

1. Fold up cover in front of the headlights.

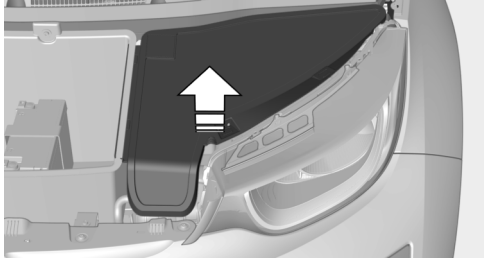

2. Turn the lid counterclockwise and remove.

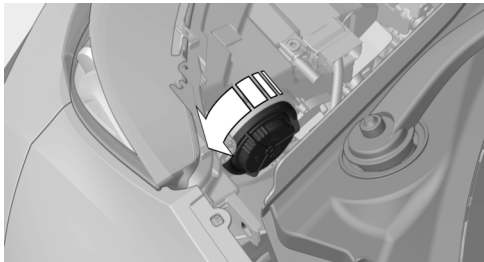

3. Pull off the connector.

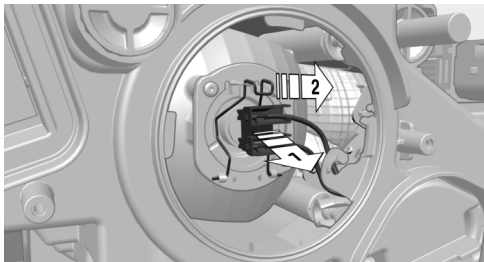

4. Press bulb holder slightly inward, loosen it to the right from the anchor and fold it down.
5. Turn the bulb counterclockwise and remove.

6. To insert the bulb and bulb holder, proceed in reverse order of removal. Make sure that the bulb holder snaps into place.
7. Close the headlight housing with the lid. Make sure that the lid engages.

LED headlights

Hints

With LED headlamps, all front lights and parking lights/daytime running lights are designed with LED technology.

Contact your service center in the event of a malfunction.

At a glance

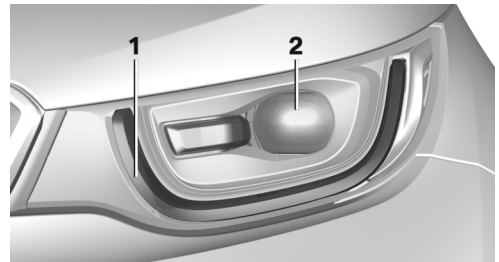

- 1 Parking lights / daytime running lights
- 2 Low beams

Parking lights/daytime running lights

Parking lights/daytime running lights are designed with LED technology.

Contact your service center in the event of a malfunction.

Turn signal and high beams

Follow general instructions, refer to page 187.

Access

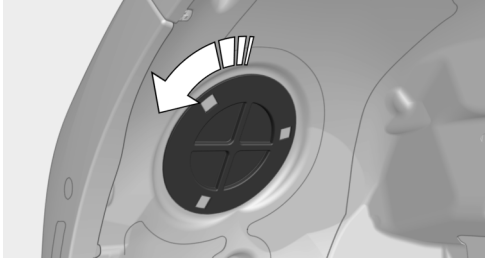

In the wheel house, turn the cover counterclockwise and remove it.

Turn signal

24-watt bulb, PSY24W.

1. Turn the left bulb holder counterclockwise and remove.

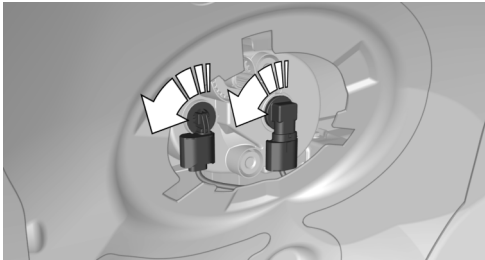

2. Press the bulb gently into the socket, turn counterclockwise and remove.
3. Install the new bulb and bulb holder in reverse order of removal.
4. Attach the cover to the wheel house.

High beams

55-watt bulb, H11.

1. Turn the right bulb holder counterclockwise and remove.

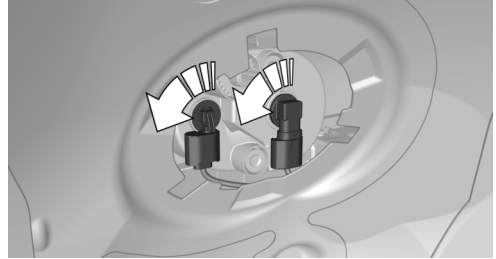

2. Press the bulb gently into the socket, turn counterclockwise and remove.
3. Install the new bulb and bulb holder in reverse order of removal.
4. Attach the cover to the wheel house.

Turn signal in exterior mirror

Follow general instructions, refer to page 187.

The turn signals in the exterior mirrors feature LED technology. Contact your service center in the event of a malfunction.

Tail lights, bulb replacement

Follow the general instructions on lamps and bulbs, refer to page 187.

The tail lights in the tailgate feature LED technology.

The lights in the bumper include the function of the rear fog lamp and the reverse gear lights.

In addition, the lights in the bumper assume the function of the tail lights if the tailgate is opened.

Contact your service center in the event of a malfunction.

Changing wheels

Hints

Which is why no spare tire is available.

The tools for changing wheels are available as accessories from your service center.

Jacking points for the vehicle jack

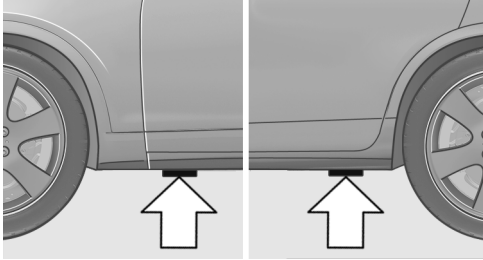

The jacking points for the vehicle jack are located at the positions shown.

Vehicle battery

The vehicle battery has 12 volts. The battery supplies the onboard electronics with energy.

Information about the high-voltage system, refer to page 156.

Maintenance

The battery is maintenance-free.

The added amount of acid is sufficient for the service life of the battery.

Further information about the battery can be obtained from your service center.

Battery replacement



Use approved vehicle batteries only

Only use vehicle batteries that have been approved for your vehicle by the manufacturer; otherwise, the vehicle could be damaged and systems or functions may not be fully available. ◀

After a battery replacement, have the battery registered on the vehicle by your service center to ensure that all comfort features are fully available and that any Check Control messages of these comfort features are no longer displayed.

Charge vehicle battery



Do not use any charging devices

Do not charge the vehicle battery with an external charging device; otherwise, there is a risk of property damage, e. g., to the vehicle's electronics. ◀

Charging a discharged battery, refer to page 164.

Power failure

After a temporary power loss, some equipment needs to be newly initialized or individual settings updated, e.g.:

- ▷ Seat and mirror memory: store the positions again.
- ▷ Time: update.
- ▷ Date: update.
- ▷ Glass sunroof and sliding visor: initialize the system, refer to page 50.

Disposing of old batteries



Have old batteries disposed of by your service center or bring them to a recycling center.

Maintain the battery in an upright position for transport and storage. Secure the battery so that it does not tip over during transport.

Fuses

Hints



Replacing fuses

Never attempt to repair a blown fuse and do not replace a defective fuse with a substitute of another color or amperage rating; this could lead to a circuit overload, ultimately resulting in a fire in the vehicle. ◀

Replacing fuse

The fuses are located in the passenger footwell under the dashboard.

1. To open, loosen screws, arrow 1.

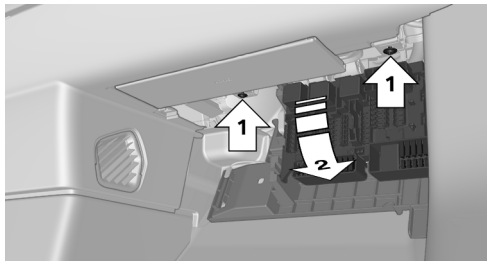

2. Fold down the fuse holder, arrow 2.
Information on the fuse types and locations is found on a separate sheet.
3. Replace the fuse in question.
4. The installation is done in reverse order from the removal.

Breakdown assistance

Vehicle features and options

This chapter describes all standard, country-specific and optional features offered with the series. It also describes features that are not necessarily available in your car, e. g., due to the selected options or country versions. This also applies to safety-related functions and systems.

Hazard warning flashers



The button is located in the center console.

Intelligent Emergency Request

The concept

In case of an emergency, an Emergency Request can be made through this system.

General information

Only press the SOS button in an emergency.

Hints

 Emergency Request not guaranteed
For technical reasons, the Emergency Request cannot be guaranteed under unfavorable conditions. ◀

At a glance



SOS button in the roofliner

Requirements

- ▷ The SIM card integrated in the vehicle has been activated.
- ▷ The radio-ready state is switched on.
- ▷ The Assist system is functional.

Initiating an Emergency Request

1. Press the cover briefly to open it.
2. Press the SOS button until the LED at the button lights up green.
 - ▷ The LED lights up green: an Emergency Request was initiated.
If a cancel prompt appears on the display, the Emergency Request can be aborted.
If the situation allows, wait in your vehicle until the voice connection has been established.
 - ▷ The LED flashes green when a connection to the BMW Response Center has been established.

When the emergency request is received at the BMW Response Center, the BMW Response Center contacts you and takes further steps to help you.

Even if you are unable to respond, the BMW Response Center can take further

steps to help you under certain circumstances.

For this, data are transmitted to the BMW Response Center which serve to determine the necessary rescue measures. E. g. the current position of the vehicle, if it can be established.

- ▶ If the LED is flashing green, but the BMW Response Center can no longer be heard via the speaker, you can nevertheless still be heard at the BMW Response Center.

Initiating an Emergency Request automatically

Under certain conditions, an Emergency Request is automatically initiated immediately after a severe accident. Automatic Collision Notification is not affected by pressing the SOS button.

Warning triangle



The warning triangle is located on the inside of the tailgate.

To remove, loosen the bracket.

First aid kit

Note

Some of the articles have a limited service life. Check the expiration dates of the contents regularly and replace any expired items promptly.

Storage

The first aid kit is located at the rear of the cargo area.

Roadside Assistance

Service availability

Roadside Assistance can be reached around the clock in many countries. You can obtain assistance there in the event of a vehicle breakdown.

Roadside Assistance

The Roadside Assistance phone number can be viewed on the iDrive or a connection to Roadside Assistance can be established directly.

Jump-starting

 Not jumping or directly charging the vehicle battery

Do not jump or directly charge the vehicle battery using conventional jump starting; otherwise, because of the high voltage of the drive system, there is a danger of fatal injury from electrocution. ◀

If the high-voltage battery and the vehicle battery are discharged, it is not possible to operate the vehicle. In this case, do not give a jump start, but instead charge the battery as usual using the charging cable, refer to page 164.

Towing

Note

 Tow-starting and towing
For towing the vehicle turn, switch off the Intelligent Safety systems; otherwise malfunctions of the individual braking systems might lead to accidents. ◀

Transporting your vehicle

Note

Your vehicle is not permitted to be towed. Therefore, contact a service center in the event of a breakdown.

 Do not have the vehicle towed. Have your vehicle transported on a loading platform only; otherwise, damage may occur. ◀

Tow truck

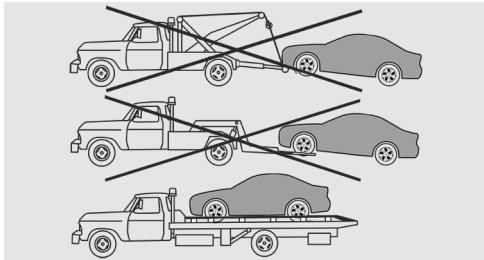

The vehicle should only be transported on a loading platform.

 Do not lift the vehicle. Do not lift the vehicle by the tow fitting or body and chassis parts; otherwise, damage may result. ◀

Use tow fitting located in the front only for positioning the vehicle.

Pushing vehicle

To remove a disabled vehicle from the danger area, push it for a short distance at a speed of no more than 6 mph/10 km/h.

The vehicle can only be pushed in selector lever position N.

In order to ensure that the vehicle can roll, proceed as follows:

1. Switch on drive readiness, refer to page 62.
2. Depress brake pedal.

3. Engage selector lever position N.

If there are electrical malfunctions, it may happen that you can't change the selector lever position.

Towing other vehicles

Hints

 Light towing vehicle. The towing vehicle must not be lighter than the vehicle being towed; otherwise, it will not be possible to control the vehicle's response. ◀

 Attaching the tow bar/tow rope correctly. Attach the tow bar or tow rope to the tow fitting; connecting it to other vehicle parts may cause damage. ◀

- ▷ Switch on the hazard warning system, depending on local regulations.
- ▷ If the electrical system has failed, clearly identify the vehicle being towed by placing a sign or a warning triangle in the rear window.

Tow bar

The tow fittings used should be on the same side on both vehicles.

Should it prove impossible to avoid mounting the tow bar at an offset angle, please observe the following:

- ▷ Maneuvering capability is limited going around corners.
- ▷ The tow bar will generate lateral forces if it is secured with an offset.

Tow rope

When starting to tow the vehicle, make sure that the tow rope is taut.

To avoid jerking and the associated stresses on the vehicle components when towing, always use nylon ropes or nylon straps.

Tow fitting

The screw-in tow fitting should always be carried in the vehicle.

The tow fitting can be screwed in at the front or rear of the BMW.

The tow fitting is located in the storage compartment under the hood.

 Tow fitting, information on use

- ▷ Use only the tow fitting provided with the vehicle and screw it all the way in.
- ▷ Use the tow fitting for towing on paved roads only.
- ▷ Use tow fitting located in the front only for positioning the vehicle.
- ▷ Avoid lateral loading of the tow fitting, e.g., do not lift the vehicle by the tow fitting.

Otherwise, damage to the tow fitting and the vehicle can occur. ◀

Screw thread for tow fitting

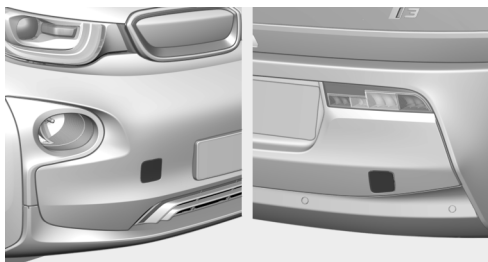

Press on the mark on the edge of the cover to push it out.

Safety of the high-voltage system

Working on the vehicle

 Maintenance and repairs

Have maintenance and repair work performed only by a service center or a workshop that works according to BMW specifications

with appropriately trained personnel. Otherwise, there is the risk of fatal injury from electrocution due to the high-voltage system's high voltage. ◀



Body work and working on the high-voltage system

Do not perform any modifications or work on the vehicle, especially maintenance and repair work on the high-voltage system and the carbon body and avoid retrofitting accessories.

If work is not carried out properly, there is the risk of fire and fatal injury from electrocution due to the high-voltage system's high voltage.

Modifications and work on the vehicle may only be carried out by an authorized BMW i service center or one that operates according to BMW i specifications with personnel trained accordingly. ◀

Your vehicle's high-voltage system is a self-contained system. Safety is ensured as long as no work is performed on technical components or on the chassis.

High-voltage system: contact with water

The high-voltage system is typically safe even in the following example situations:

- ▷ Water in the footwell, for instance after a rainstorm when sunroof was kept open.
- ▷ Vehicle is in water but only up to the allowed height.
- ▷ Liquid slides in the cargo area.

In these cases there is no risk of injury from electrocution. Other damage to the vehicle is possible.

High-voltage system: automatic deactivation

If an accident occurs, the high-voltage system is switched off automatically to prevent risk of danger to occupants and other traffic.

Read the information on What to do after an accident, refer to page 197.

What to do after an accident

Hints



After an accident

After an accident, do not touch any high-voltage components such as orange colored high-voltage cables or parts that are in contact with exposed high-voltage cables. Otherwise, there is the risk of fatal injury from electrocution due to the system's high voltage. ◀



Esiding fluids

Do not touch any fluids esiding from the high-voltage battery, or the skin can sustain chemical burns. ◀

General information

If you are involved in an accident with your vehicle, compliance with the following additional safety precautions is required with regard to the high-voltage system:

- ▷ Secure the crash site.
- ▷ Immediately notify rescue forces, police, or firefighters of the fact that your vehicle is equipped with a high-voltage system.
- ▷ Engage selector lever position P, set the parking brake and reel off operating and drive readiness.
- ▷ Lock the vehicle after exiting.
- ▷ Do not inhale any gases esiding from the high-voltage battery; if needed, maintain a safe distance from the vehicle.

Care

Vehicle features and options

This chapter describes all standard, country-specific and optional features offered with the series. It also describes features that are not necessarily available in your car, e. g., due to the selected options or country versions. This also applies to safety-related functions and systems.

Car washes

General information

Regularly remove foreign objects such as leaves in the area below the windshield when the hood is raised.

Wash your vehicle frequently, particularly in winter. Intense soiling and road salt can damage the vehicle.

Hints



Closing the charging port flap

Close the charging port flap while washing the vehicle. Otherwise, the vehicle could be damaged. ◀



Steam jets or high-pressure washers

When using steam jets or high-pressure washers, hold them a sufficient distance away and use a maximum temperature of 140 °F/60 °C.

If the vehicle has a glass sunroof and charging port flap, ensure that a distance of at least 31.5 inches/80 cm is maintained. Holding them too close or using excessively high pressures or temperatures can cause damage or preliminary damage that may then lead to long-term damage.

Follow the user's manual for the high-pressure washer. ◀



Cleaning sensors/cameras with high-pressure washers

When using high-pressure washers, do not spray the exterior sensors and cameras, e.g., Park Distance Control, for extended periods of time and only from a distance of at least 12 in/30 cm. ◀



Have the charging port cleaned by trained personnel

If the charging port is dirty, have the car cleaned only by appropriately trained personnel. Otherwise, there is a danger of injury from high voltage. ◀

Automatic car washes

Hints



Do not use high pressure washing systems

With washing systems operating at high pressures and nozzle positions close to the windows, drops of water can penetrate. ◀

- ▷ Give preference to cloth car washes or those that use soft brushes in order to avoid paint damage.
- ▷ Make sure that the wheels and tires are not damaged by the transport mechanisms.
- ▷ Fold in the exterior mirrors; otherwise, they may be damaged, depending on the width of the vehicle.
- ▷ Unscrew the rod antenna.
- ▷ Deactivate the rain sensor, refer to page 71, to avoid unintentional wiper activation.
- ▷ In some cases, an unintentional alarm can be triggered by the interior motion sensor of the alarm system. Follow the instructions on avoiding an unintentional alarm, refer to page 47.



Guide rails in car washes

Avoid car washes with guide rails higher than 4 in/10 cm; otherwise, the vehicle body could be damaged. ◀

Before driving into a car wash

In order to ensure that the vehicle can roll in a car wash, take the following steps:

1. Drive into the car wash.
2. Engage selector lever position N.
3. Remove foot from brake pedal.
4. Press the Start/Stop button.

In this way, operating readiness remains switched on, and a Check-Control message is displayed.

To activate drive readiness:

1. Depress the brake pedal.
2. Press the Start/Stop button.

Pressing the Start/Stop button without stepping on the brake turns operating readiness off.

Selector lever position

Selector lever position P is engaged automatically:

- ▷ With operating readiness turned off.
- ▷ After approx. 15 minutes.

Headlights

- ▷ Do not rub dry and do not use abrasive or acidic cleansers.
- ▷ Soak areas that have been dirtied e. g., from insects, with shampoo and wash off with water.
- ▷ Thaw ice with de-icing spray; do not use an ice scraper.

After washing the vehicle

After washing the vehicle, apply the brakes briefly to dry them; otherwise, braking action

can be reduced and corrosion of the brake discs can occur.

Completely remove all residues on the windows, to minimize loss of visibility due to smearing and to reduce wiper noises and wiper blade wear.

Vehicle care

Car care products

BMW recommends using care and cleaning products from BMW, since these have been tested and approved.



Car care and cleaning products

Follow the instructions on the container.

When cleaning the interior, open the doors or windows.

Only use products intended for cleaning vehicles.

Cleansers can contain substances that are dangerous and harmful to your health. ◀

Vehicle paint

Regular care contributes to driving safety and value retention. Environmental influences in areas with elevated air pollution or natural contaminants, such as tree resin or pollen can affect the vehicle's paintwork. Tailor the frequency and extent of your car care to these influences.

Aggressive substances such as spilled fuel, oil, grease or bird droppings, must be removed immediately to prevent the finish from being altered or discolored.

Leather care

Remove dust from the leather often, using a cloth or vacuum cleaner.

Otherwise, particles of dust and road grime chafe in pores and folds, and lead to increased wear and premature degradation of the leather surface.

To guard against discoloration, such as from clothing, provide leather care roughly every two months.

Clean light-colored leather more frequently because soiling on such surfaces is substantially more visible.

Use leather care products; otherwise, dirt and grease will gradually break down the protective layer of the leather surface.

Suitable care products are available from the service center.

Upholstery material care

Vacuum regularly with a vacuum cleaner.

If upholstery is very dirty, e.g., with beverage stains, use a soft sponge or microfiber cloth with a suitable interior cleaner.

Clean the upholstery down to the seams using large sweeping motions. Avoid rubbing the material vigorously.

 **Damage from Velcro® fasteners**
Open Velcro® fasteners on pants or other articles of clothing can damage the seat covers. Ensure that any Velcro® fasteners are closed. ◀

Caring for special components

Light-alloy wheels

When cleaning the vehicle, use only neutral wheel cleaners having a pH value from 5 to 9. Do not use abrasive cleaning agents or steam jets above 140 °F/60 °C. Follow the manufacturer's instructions.

Aggressive, acidic or alkaline cleaning agents can destroy the protective layer of adjacent components, such as the brake disk.

Chrome surfaces

Carefully clean components such as the radiator grille or door handles with an ample supply of water, possibly with shampoo added, partic-

ularly when they have been exposed to road salt.

Rubber components

Aside from water, treat only with rubber cleansers.

When cleaning rubber seals, do not use any silicon-containing car care products in order to avoid damage or noises.

Fine wood parts

Clean fine wood facing and fine wood components only with a moist rag. Then dry with a soft cloth.

Plastic components

These include:

- ▷ Imitation leather surfaces.
- ▷ Roofliner.
- ▷ Lamp lenses.
- ▷ Instrument cluster cover.
- ▷ Matt black spray-coated components.
- ▷ Painted parts in the interior.
- ▷ Carbon parts in the interior.

Clean with a microfiber cloth.

Dampen cloth lightly with water.

Do not soak the roofliner.

 No cleansers that contain alcohol or solvents

Do not use cleansers that contain alcohol or solvents, such as lacquer thinners, heavy-duty grease removers, fuel, or such; this could lead to surface damage. ◀

Safety belts

Dirty belt straps impede the reeling action and thus have a negative impact on safety.

 **Chemical cleaning**
Do not clean chemically; this can destroy the webbing. ◀

Use only a mild soapy solution, with the safety belts clipped into their buckles.

Do not allow the reels to retract the safety belts until they are dry.

Carpets and floor mats

 No objects in the area around the pedals
Keep floor mats, carpets, and any other objects out of the pedal area; otherwise, the function of the pedals could be impeded while driving and create the risk of an accident.

Do not place additional floor mats over existing mats or other objects.

Only use floor mats that have been approved for the vehicle and can be properly attached to floor.

Ensure that the floor mats are securely fastened again after they were removed for cleaning, e.g. ◀

Floor mats can be removed from the car's interior for cleaning.

If the floor carpets are very dirty, clean with a microfiber cloth and water or a textile cleaner. To prevent matting of the carpet, rub back and forth in the direction of travel only.

Sensors/cameras

To clean sensors and cameras, use a cloth moistened with a small amount of glass cleaner.

Displays/monitors

 Cleaning displays and screens
Do not use any chemical or household cleaning agents; otherwise, surfaces can be affected. ◀

 Keeping out moisture
Keep all fluids and moisture away from the unit; otherwise, electrical components can be damaged. ◀

 Avoid pressure
Avoid pressing too hard when cleaning and do not use abrasive materials; otherwise, damage can result. ◀

Clean with a clean, antistatic microfiber cloth.

Long idle times and long-term vehicle storage

 Do not allow the vehicle to sit idle for extended periods with a low charging state
Before storing the vehicle for an extended period, check the battery charge indicator to ensure that the high-voltage battery is fully charged. For longer idle times, park the vehicle with a charging plug plugged into a suitable power source. Regularly check charging state. Otherwise, the high-voltage battery can be damaged when there is excessive discharge. ◀

For idle phases that last several weeks, park the vehicle with a fully charged battery if possible.

Do not park the vehicle for longer than 14 days if the electric range is less than 6 mls, approx. 10 km.

With storage times of up to three months, if possible plug the vehicle into a suitable power source or park it in a nearly fully charged state.

Note

The service center can advise you on what to consider when storing the vehicle for longer than three months.



Reference

This chapter contains the technical data and an index that will quickly take you to the information you need.

Technical data

Vehicle features and options

This chapter describes all standard, country-specific and optional features offered with the series. It also describes features that are not

necessarily available in your car, e. g., due to the selected options or country versions. This also applies to safety-related functions and systems.

Note

The technical data and specifications in this Owner's Manual are used as guidance values. The vehicle-specific data can deviate from this, for example, due to the selected special equipment, country version or country-specific measurement method. Detailed values can be

found in the approval documents, on information signs on the vehicle or can be obtained from the service center.

The information in the vehicle documents always has priority.

Dimensions

Note

The dimensions can vary depending on the model version, equipment or country-specific measurement method.

The specified heights do not take into account attached parts, for example, a roof antenna,

roof racks or spoiler. The heights can deviate, for example, due to the selected special equipment, tires, load and chassis version.

BMW i3

Width including exterior mirrors	inches/mm	80.3/2,039
Width not including side mirrors	inches/mm	69.9/1,775
Height	inches/mm	62.1/1,578
Length	inches/mm	157.8/4,008
Wheelbase	inches/mm	101.2/2,570
Smallest turning radius diam.	ft/m	32.4/9.86

Weights/Volume

BMW i3 without Range Extender		
Approved gross vehicle weight	lbs/kg	3,615/1,640
Load	lbs/kg	715/324
Approved front axle load	lbs/kg	1,720/780
Approved rear axle load	lbs/kg	2,005/909
Cargo area capacity	cu ft/liters	15.1–36.9/260–1,100

BMW i3 with Range Extender		
Approved gross vehicle weight	lbs/kg	3,815/1,730
Load	lbs/kg	650/295
Approved front axle load	lbs/kg	1,785/810
Approved rear axle load	lbs/kg	2,205/1,000
Cargo area capacity	cu ft/liters	15.1–36.9/260–1,100

Capacities

	US gal/liters	Notes
Fuel tank, approx.	1.9/7	With optional Range Extender

Appendix

Any updates to the Owner's Manual of the vehicle are listed here.

Correction to the Owner's Manual

Opposite to the description in this Owner's Manual, the following changes were implemented after the editorial deadline:

Remote control

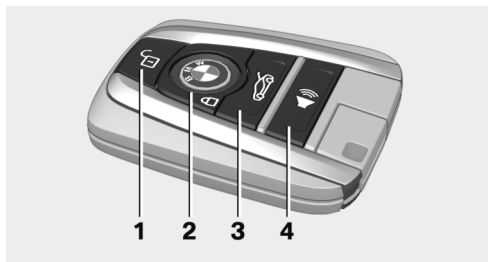

- 1 Unlocking
- 2 Locking
- 3 Unlock the tailgate
- 4 Panic mode

Tailgate

Unlock the tailgate

 Press button on the remote control for approx. 1 second to unlock the tailgate.

Depending on the settings, the doors are unlocked as well.

Unlocking the tailgate separately in the case of Comfort Access

Press button on tailgate's exterior.



This corresponds to pressing the remote control button.

Hood

Opening from the outside

The hood cannot be opened from the outside.

Unlocking hood

The hood cannot be unlocked using the remote control.



Press the button in the driver's floor area to unlock the button.

Adjusting

Unlocking

The settings for hood and tailgate are not available.

Everything from A to Z

Index

A

ABS, Antilock Brake System 106

ACC, Active Cruise Control with Stop & Go 109

Accelerator pedal positions 66

AC quick charging cable, see Level 2 charging cable 158

Activated-charcoal filter 132

Active Cruise Control with Stop & Go, ACC 109

Adjustments, seats/head restraints 51

Adjustments, steering wheel 57

After washing vehicle 199

Airbags 92

Airbags, indicator/warning light 93

Air circulation, refer to Recirculated-air mode 128, 131

Air conditioner 127

Air, dehumidifying, refer to Cooling function 128, 130

Air distribution, manual 128, 130

Air flow, air conditioner 128

Air flow, automatic climate control 131

Air pressure, tires 170

Air vents, refer to Ventilation 132

Alarm system 46

Alarm, unintentional 47

All around the center console 16

All around the roofliner 17

All around the steering wheel 14

All-season tires, refer to Winter tires 174

Antifreeze, washer fluid 72

Antilock Brake System, ABS 106

Anti-slip control, refer to DSC 106

Approved axle load 205

Ash tray 134

Assistance, Roadside Assistance 194

Assistance when driving off 108

Assist system, refer to Intelligent Safety 99

AUTO intensity 131

Automatic car wash 198

Automatic climate control 129

Automatic cornering adjustment 56

Automatic Cruise Control with Stop & Go 109

Automatic Curb Monitor 55

Automatic deactivation, front-seat passenger airbags 94

Automatic deactivation of the high-voltage system 196

Automatic headlight control 90

Automatic locking 46

Automatic recirculated-air control 131

AUTO program, automatic climate control 130

AUTO program, intensity 131

Average fuel consumption 86

Average speed 86

Axle loads, weights 205

B

Backup charging 164

Band-aids, refer to First aid kit 194

Bar for tow-starting/towing 195

Battery, 12 volt 191

Battery replacement, vehicle battery 191

Battery replacement, vehicle remote control 36

Battery state indicator 76

Battery, vehicle 191

Being pulled, referred to Towing 194

Belts, safety belts 53

Beverage holder, cupholder 139

BMW Assist 6

BMW eDRIVE 31

BMW maintenance system 185

Body work, see Working on the vehicle 196

Bottle holder, refer to Cupholders 139

Brake assistant 106

Brake discs, break-in 144

Brake pads, break-in 144

Braking, hints 146

Breakdown assistance 193, 194

Break-in 144

Brightness of Control Display 88

Bulb replacement 187

Bulb replacement, front 188

Bulb replacement, tail lights 190

Bulbs and lamps 187

Button, RES 112
Button, Start/Stop 62
Bypassing, refer to Jump-starting 194

C

California Proposition 65
Warning 8
Camera-based Cruise Control 109
Camera, care 201
Camera, rearview camera 120
Can holder, refer to Cupholders 139
Car battery 191
Car care products 199
Care, displays 201
Care, vehicle 199
Cargo 148
Cargo area 135
Cargo area, enlarging 136
Cargo area, storage compartments 140
Cargo cover 135
Cargo, securing 149
Cargo straps, securing cargo 149
Car key, refer to Remote control 36
Carpet, care 201
Car wash 198
Catalytic converter, refer to Hot exhaust system 145
CBS Condition Based Service 185
Center armrest 139
Center console 16
Central locking system 42
Central screen, refer to Control Display 18
Changes, technical, refer to Safety 7
Changing wheels 191
Changing wheels/tires 173
Charging battery, see Vehicle charging 156
Charging, refer to Charging vehicle 156
Charging, refer to Vehicle charging 156
Charging screen 75
Charging state indicator, high-voltage battery 76
Charging status, see display of the charging status 160
Charging vehicle 156
Charging vehicle, refer to Vehicle charging 156
Chassis number, see vehicle identification number 10
Check Control 77
Check engine oil 181
Check oil level 181
Children, seating position 58
Children, transporting safely 58
Child restraint fixing system 58
Child restraint fixing system LATCH 59
Child restraint fixing systems, mounting 58
Child seat, mounting 58
Child seats 58
Chrome parts, care 200
Cigarette lighter 134
Cleaning displays 201
Climate control 127, 129
Clock 82
Closing/opening via door lock 41
Closing/opening with remote control 39
Clothes hooks 140
Coasting 67
Combination reel, refer to Turn signals 69
Combination reel, refer to Wiper system 70
Comfort Access 44
COMFORT program, Dynamic Driving Control 107
Compartments in the doors 138
Compressor 174
Computer 85
Condensation on windows 128, 131
Condensation under the vehicle 147
Condition Based Service CBS 185
Confirmation signal 46
ConnectedDrive 6
ConnectedDrive Services 6
Connecting electrical devices 134
Contact with water, high-voltage system 196
Control Display 18
Control Display, settings 87
Controller 18
Control systems, driving stability 106
Convenient opening with the remote control 39
Coolant 183
Coolant temperature 81
Cooling function 128, 130
Cooling, maximum 131
Cooling system 183
Corrosion on brake discs 146
Cosmetic mirror 134
Cruise control 115
Cruise control, active with Stop & Go 109
Cruise control, refer to Camera-based Cruise Control 109
Cruising range 82
Cupholders 139
Current fuel consumption 86

D

Damage, tires 173

- Data, technical 204
Daytime running lights 90
Defrosting, refer to Windows, defrosting 128, 131
Dehumidifying, air 128, 130
Deleting personal data 24
Deletion of personal data 24
Departure times, stationary climate control 133
Digital clock 82
Dimensions 204
Dimmable exterior mirrors 56
Dimmable interior rearview mirror 57
Direction indicator, refer to Turn signals 69
Display for performance and energy recovery 76
Display lighting, refer to Instrument lighting 90
Displays 74
Displays, cleaning 201
Displays, eDRIVE system 75
Displays, high-voltage system 75
Disposal, coolant 184
Disposal, vehicle battery 191
Distance control, refer to PDC 117
Divided screen view, split screen 23
Door lock 41
Door lock, refer to Remote control 36
Drive display 76
Drive-off assistant 108
Drive-off assistant, refer to DSC 106
Drive readiness in detail 63
Drive readiness, switching off 65
Drive readiness, switching on 63
Driving Dynamics Control 107
Driving in detail 66
Driving instructions, break-in 144
Driving instructions, eDRIVE drive system 144
Driving mode 107
Driving notes, general 145
Driving, refer to drive readiness in detail 63
Driving stability control systems 106
Driving, Start/Stop button 62
Driving style analysis 153
Driving tips 145
DSC Dynamic Stability Control 106
DTC Dynamic Traction Control 107
Dynamic Stability Control DSC 106
Dynamic Traction Control DTC 107
- ## E
- ECO PRO 151
ECO PRO+ 151
ECO PRO display 151
ECO PRO driving mode 151
ECO PRO driving style analysis 153
ECO PRO mode 151
ECO PRO Tip - driving instruction 152
eDRIVE drive system, driving instructions 144
eDRIVE, electric driving, see BMW eDRIVE 31
eDrive system, at a glance 31
eDRIVE system, displays 75
EfficientDynamics 152
Electric driving 66
Electric driving, see BMW eDRIVE 31
Electric range 82
Electronic Stability Program ESP, refer to DSC 106
Emergency charging, refer to Backup charging 164
Emergency detection, remote control 37
Emergency release, fuel filler flap 166
Emergency Request 193
Emergency service, refer to Roadside Assistance 194
Emergency start function, engine start 37
Emergency unlocking, transmission lock 65
Energy Control 86
Energy recovery, displaying 76
Energy recovery, driving stability control systems 106
Engine coolant 183
Engine oil 181
Engine oil, adding 182
Engine start during malfunction 37
Engine start, jump-starting 194
Entering a car wash 198
Error displays, see Check Control 77
ESP Electronic Stability Program, refer to DSC 106
Exchanging wheels/tires 173
Exhaust system 145
Exterior mirror, automatic dimming feature 56
Exterior mirrors 55
External start 194
External temperature display 81
External temperature warning 81
Eyes for securing cargo 149
- ## F
- Failure message, see Check Control 77

False alarm, refer to Unintentional alarm 47
Fan, refer to Air flow 128, 131
Fine wood, care 200
First aid kit 194
Fitting for towing, see tow fitting 196
Flat tire, changing wheels 191
Flat Tire Monitor FTM 98
Flat tire, Tire Pressure Monitor TPM 95
Flat tire, warning lamp 96, 98
Flooding 146
Floor carpet, care 201
Floor mats, care 201
Fold-out position, wiper 72
Foot brake 146
Front airbags 92
Front-end collision warning with City Braking function 100
Front lights 188
front-seat passenger airbags, automatic deactivation 94
Front-seat passenger airbags, indicator lamp 94
FTM Flat Tire Monitor 98
Fuel 168
Fuel consumption, current 86
Fuel consumption, refer to Average fuel consumption 86
Fuel filler flap 165
Fuel gauge, Range Extender 81
Fuel lid 165
Fuel quality 168
Fuel recommendation 168
Fuel, tank lidacity 205
Fuse 192

G

Gasoline 168

General driving notes 145
Glare shield 134
Glass sunroof, powered 49
Glove compartment 138
GPS location, vehicle position 88
Gross vehicle weight, approved 205

H

Halogen headlights, bulb replacement 0
Handbrake, refer to parking brake 68
Hazard warning flashers 193
Head airbags 92
Headlight control, automatic 90
Headlight courtesy delay feature 89
Headlight courtesy delay feature, remote control 46
Headlight courtesy delay feature via remote control 40
Headlight flasher 70
Headlight glass 188
Headlights 188
Headlights, care 199
Head restraints 51
Head restraints, front 54
Head restraints, rear 54
Heavy cargo, stowing 149
Height, vehicle 204
High beams 70
High beams, bulb replacement 189
High-voltage battery, charging state indicator 76
High-voltage battery, discharge 145
High-voltage battery, heated 67
High-voltage battery, heavily discharged 67

High-voltage system, automatic deactivation 196
High-voltage system, contact with water 196
High-voltage system, displays 75
High-voltage system, safety 196
Hills 146
Hill start assistant, refer to Drive-off assistant 108
Hints 6
Holder for beverages 139
Hold function 69
Hood 42
Hood via remote control 40
Horn 14
Hot exhaust system 145
Hydroplaning 146

I

Ice warning, see External temperature warning 81
Icy roads, see External temperature warning 81
Identification marks, tires 171
Identification number, see vehicle identification number 10
iDrive 18
Ignition key, refer to Remote control 36
Illuminant replacement 187
Important under the hood 179
Increase range 150
Increase range with Range Extender 67
Indication of a flat tire 96, 98
Indicator and alarm lamps, see Check Control 77
Indicator lamp, see Check Control 77
Individual air distribution 128, 130

Individual settings, refer to
Personal Profile 37
Inflation pressure, tires 170
Inflation pressure warning
FTM, tires 98
Info display, refer to Com-
puter 85
Initialize, Tire Pressure Moni-
tor TPM 96
Initializing, Flat Tire Monitor
FTM 98
Instrument cluster 74
Instrument lighting 90
Integrated key 36
Integrated Owner's Manual in
the vehicle 29
Intelligent Emergency Re-
quest 193
Intelligent Safety 99
Intensity, AUTO pro-
gram 131
Interior lights 91
Interior lights via remote con-
trol 39
Interior motion sensor 47
Interior rearview mirror, auto-
matic dimming feature 57
Interior rearview mirror, man-
ually dimmable 56
Interval display, service re-
quirements 82

J

Jacking points for the vehicle
jack 191
Jump-starting 194
Jump starting, refer to
Backup charging 164

K

Key/remote control 36
Keyless Go, refer to Comfort
Access 44

Key Memory, refer to Per-
sonal Profile 37
Knee airbag 92

L

Lamp replacement, front 188
Lamp replacement, see Bulb
replacement 187
Language on Control Dis-
play 87
Lashing eyes, securing
cargo 149
LATCH child restraint sys-
tem 59
Leather, care 199
LED headlights, bulb replace-
ment 189
LEDs, light-emitting di-
odes 188
Length, vehicle 204
Letters and numbers, enter-
ing 24
Level 1 Charging 161
Level 1 charging cable 157
Level 2 Charging 162
Level 2 charging cable 158
Light alloy wheels, care 200
Light-emitting diodes,
LEDs 188
Lighter 134
Lighting 89
Lighting via remote con-
trol 39
Light reel 89
Lights 89
Load 149
Loading 148
Lock, door 41
Locking/unlocking via door
lock 41
Locking/unlocking with re-
mote control 39
Locking, automatic 46
Locking, settings 45
Locking via tailgate 43

Longer idle phases 201
Long idle times and long-term
vehicle storage 201
Long-term vehicle stor-
age 201
Low beams 89

M

Maintaining charging state,
see Range Extender 67
Maintenance 185
Maintenance require-
ments 185
Maintenance, service require-
ments 82
Maintenance system,
BMW 185
Make-up mirror 134
Malfunction displays, see
Check Control 77
Manual air distribu-
tion 128, 130
Manual air flow 128, 131
Manual operation, door
lock 41
Manual operation, exterior
mirrors 55
Manual operation, fuel filler
flap 166
Manual operation, Park Dis-
tance Control PDC 118
Manual operation, rearview
camera 120
Marking on approved
tires 174
Master key, refer to Remote
control 36
Maximum cooling 131
Maximum speed, display 83
Maximum speed, winter
tires 174
Measure, units of 88
Medical kit 194
Menu, EfficientDynamics 152

Menu in instrument cluster 84
Menus, operating, iDrive 18
Menus, refer to iDrive operating concept 19
Messages, see Check Control 77
Microfilter 129, 132
Minimum tread, tires 172
Mirrors 55
Mobile communication devices in the vehicle 145
Mobility System 174
Modifications, technical, refer to Safety 7
Moisture in headlight 188
Monitor, refer to Control Display 18
Mounting of child restraint systems 58
Multifunction steering wheel, buttons 14
Multimedia 6

N

Navigation 6
Neck restraints, front, refer to Head restraints 54
Neck restraints, rear, refer to Head restraints 54
Neutral cleaner, see wheel cleaner 200
New wheels and tires 173
Nylon rope for tow-starting/towing 195

O

OBD Onboard Diagnosis 186
OBD, see OBD Onboard Diagnosis 186
Obstacle marking, rearview camera 121
Octane rating, refer to Recommended fuel grade 168

Odometer 81
Office 6
Oil 181
Oil, adding 182
Oil change interval, service requirements 82
Old batteries, disposal 191
Onboard monitor, refer to Control Display 18
Opening/closing via door lock 41
Opening and closing 36
Opening and closing, without remote control 41
Opening and closing, with remote control 39
Operating concept, iDrive 18
Optional equipment, standard equipment 6
Outside air, refer to Automatic recirculated-air control 131
Overheating of engine, refer to Coolant temperature 81

P

Paint, vehicle 199
Parallel parking assistant 122
Park Distance Control PDC 117
Parked vehicle, condensation 147
Parking aid, refer to PDC 117
Parking assistant 122
Parking brake 68
Parking lights 89
Passenger side mirror, tilting downward 55
Pathway lines, rearview camera 121
PDC Park Distance Control 117
Pedestrian warning with city braking function 102
Performance display 76

Personal Profile 37
Personal Profile, exporting profiles 38
Pinch protection system, glass sunroof 49
Pinch protection system, windows 48
Plastic, care 200
Power failure 191
Power sunroof, glass 49
Power windows 48
Pressure, tire air pressure 170
Pressure warning FTM, tires 98
Profile, refer to Personal Profile 37
Programmable memory buttons, iDrive 23
Protective function, glass sunroof 49
Protective function, windows 48
Pulling, refer to Towing 194
Push-and-turn reel, refer to Controller 18

Q

Quick charging cable, see Level 2 charging cable 158
Quick charging, see Level 2 Charging 162

R

Radiator fluid 183
Radio 6
Radio-operated key, refer to Remote control 36
Rain sensor 71
Range Extender, fuel gauge 81
Range Extender, increasing range 67

- Range Extender, maintenance run 67
- Rearview camera 120
- Rearview mirror 55
- Rear window defroster 128, 131
- Recirculated-air filter 132
- Recirculated-air mode 128, 131
- Recommended fuel grade 168
- Recommended tire brands 174
- Refueling 165
- Remaining range 82
- Remote control/key 36
- Remote control, malfunction 40
- Replacement fuse 192
- Replacing wheels/tires 173
- Reporting safety defects 10
- RES button 112
- RES button, see Camera-based cruise control, ACC 109
- RES button, see Cruise control 115
- Reserve warning, refer to Range 82
- Reset, Tire Pressure Monitor TPM 96
- Retaining straps, securing cargo 149
- Retreaded tires 174
- Roadside parking lights 90
- RON recommended fuel grade 168
- Roofliner 17
- Rope for tow-starting/towing 195
- Rubber components, care 200
- Safety 7
- Safety belt reminder for driver's seat and front passenger seat 53
- Safety belts 53
- Safety belts, care 200
- Safety of the high-voltage system 196
- Safety systems, airbags 92
- Screen, refer to Control Display 18
- Screw thread, see screw thread for tow fitting, screw thread for tow fitting 196
- Sealant 174
- Seat belts, refer to Safety belts 53
- Seat heating, front 52
- Seating position for children 58
- Seats 51
- Secondary lights, rear 190
- Selection list in instrument cluster 84
- Sensors, care 201
- Service and warranty 8
- Service requirements, Condition Based Service CBS 185
- Service requirements, display 82
- Service, Roadside Assistance 194
- Services, ConnectedDrive 6
- SET button, see Camera-based cruise control, ACC 109
- SET button, see Cruise control 115
- Settings, locking/unlocking 45
- Settings, mirrors 55
- Settings on Control Display 87
- Side airbags 92
- Signaling, horn 14
- Signals when unlocking 46
- Sitting safely 51
- Size 204
- Slide/tilt glass roof 49
- Smallest turning radius 204
- Snow chains 178
- Socket 134
- Socket, OBD Onboard Diagnostics 186
- SOS button 193
- Spare fuse 192
- Speed, average 86
- Speed limit detection, computer 86
- Speed limiter, display 83
- Speed Limit Information 83
- Speed warning 86
- Split screen 23
- Stability control systems 106
- Standard charging cable, see Level 1 charging cable 157
- Standard charging, see Level 1 Charging 161
- Standing air conditioning, remote control 46
- Start/Stop button 62
- Start function during malfunction 37
- Stationary climate control 132
- Status control display, tires 95
- Status information, iDrive 22
- Status of Owner's Manual 7
- Steering wheel, adjusting 57
- Storage compartments 138
- Storage compartments, locations 138
- Storage, tires 174
- Storing the vehicle 201
- Summer tires, tread 172
- Sun visor 134
- Supplementary text message 80
- Switch for Dynamic Driving 107

S

Safe braking 146

Switching on, drive readiness 63
Switch off, drive readiness 65
Switch, refer to Cockpit 14
Symbols 6
Symbols in the status field 22

T

Tailgate closing 43
Tailgate opening 43
Tailgate via remote control 40
Tail lights, bulb replacement 190
Tank unlocking, refer to Tank vent 165
Tank vent 165
Technical changes, refer to Safety 7
Technical data 204
Telephone 6
Temperature, air conditioner 128
Temperature, automatic climate control 130
Temperature display for external temperature 81
Text message, supplementary 80
Theft alarm system, refer to Alarm system 46
Tilt alarm sensor 47
Tire damage 173
Tire identification marks 171
Tire inflation pressure 170
Tire inflation pressure monitor, refer to FTM 98
Tire Pressure Monitor TPM 95
Tires, changing 173
Tire sealant 174
Tires, everything on wheels and tires 170
Tire tread 172
Tone 6

Total vehicle weight 205
Touchpad 21
Tow fitting 196
Towing 194
Tow lug, see tow fitting 196
TPM Tire Pressure Monitor 95
Traction control 107
TRACTION, driving dynamics 107
Transmission lock, electronic unlocking 65
Transporting children safely 58
Tread, tires 172
Trip computer 86
Triple turn signal activation 69
Trip odometer 81
Turning circle lines, rearview camera 121
Turning radius 204
Turn signal, bulb replacement 189
Turn signals, operation 69

U

Unintentional alarm 47
Units of measure 88
Unlocking/locking via door lock 41
Unlocking/locking with remote control 39
Unlocking, settings 45
Updates made after the editorial deadline 7
Upholstery care 200
USB interface 135

V

Vanity mirror 134
Vehicle battery 191
Vehicle battery, replacing 191

Vehicle, break-in 144
Vehicle care 199
Vehicle features and options 6
Vehicle identification number 10
Vehicle jack 191
Vehicle paint 199
Vehicle position, GPS location 88
Vehicle wash 198
Ventilation 132
Ventilation, refer to Stationary climate control 132
VIN, see vehicle identification number 10
Voice activation system 26

W

Warning and indicator lamps, see Check Control 77
Warning displays, see Check Control 77
Warning messages, see Check Control 77
Warning triangle 194
Washer fluid 72
Washer nozzles, windshield 71
Washer system 70
Washing, vehicle 198
Water, high-voltage system 196
Water on roads 146
Weights 205
Welcome lights 89
What to do after an accident 197
Wheelbase, vehicle 204
Wheel cleaner 200
Wheels, changing 173
Wheels, everything on wheels and tires 170
Wheels, Flat Tire Monitor FTM 98

Wheels, Tire Pressure Monitor TPM 95

Width, vehicle 204

Window defroster, rear 128, 131

Windows, powered 48

Windshield washer fluid 72

Windshield washer nozzles 71

Windshield washer system 70

Windshield wiper 70

Winter storage, care 201

Winter tires, suitable tires 174

Winter tires, tread 172

Wiper 70

Wiper blades, replacing 187

Wiper fluid 72

Wiper, fold-out position 72

Wiper system 70

Wood, care 200

Word match concept, navigation 24

Working on the body, see Working on the vehicle 196

Working on the high-voltage system, see Working on the vehicle 196

Working under the hood 179

