

**LINK:
CONTENT & A-Z**



The Ultimate
Driving Machine®



OWNER'S MANUAL.



THE BMW i3 AND THE BMW i3s.



WELCOME TO BMW i.

Owner's Manual.

BMW i3 and BMW i3s.

Thank you for choosing a BMW i.

The more familiar you are with your vehicle, the better control you will have on the road. We therefore strongly suggest:

Read this Owner's Manual before starting off in your new BMW i. Also use the Integrated Owner's Manual in your vehicle. It contains important information on vehicle operation that will help you make full use of the technical features available in your BMW i. The manual also contains information designed to enhance operating reliability and road safety, and to contribute to maintaining the value of your BMW i.

Any updates made after the editorial deadline can be found in the appendix of the Owner's Manual for the vehicle.

You can find supplementary information in the additional brochures in the on-board literature. Your BMW AG wishes you a safe and enjoyable drive.

TABLE OF CONTENTS

NOTES

Information	8
-------------------	---

QUICK REFERENCE

Your BMW i at a glance	18
------------------------------	----

AT A GLANCE

Cockpit	34
iDrive	38
Voice activation system	45
General settings	48
Owner's Manual media	59
BMW eDRIVE	63
Safety of the high-voltage system	66

CONTROLS

Opening and closing	70
Seats, mirrors, and steering wheel	88
Transporting children safely	96
Driving	100
Displays	114
Lights	129
Safety	133
Driving stability control systems	149
Driving comfort	153
Climate control	172
Interior equipment	181
Storage compartments	191

DRIVING TIPS

Things to remember when driving	198
Loading	202
Increasing the range	204

Navigation, Entertainment, and Communication, see Integrated Owner's Manual in the vehicle, Online Owner's Manual, BMW i Driver's Guide app.

MOBILITY

Charging the vehicle	210
Refueling	221
Fuel	224
Wheels and tires	226
Under the hood	242
Engine oil	244
Coolant	247
Maintenance	249
Replacing components	251
Breakdown assistance	254
Care	258

REFERENCE

Technical data	266
Appendix	269
Everything from A to Z	270

© 2018 Bayerische Motoren Werke

Aktiengesellschaft

Munich, Germany

Reprinting, including excerpts, only with the written consent of BMW AG, Munich.

US EnglishID5 II/18, 03 18 490

Printed on environmentally friendly paper, bleached without chlorine, suitable for recycling.

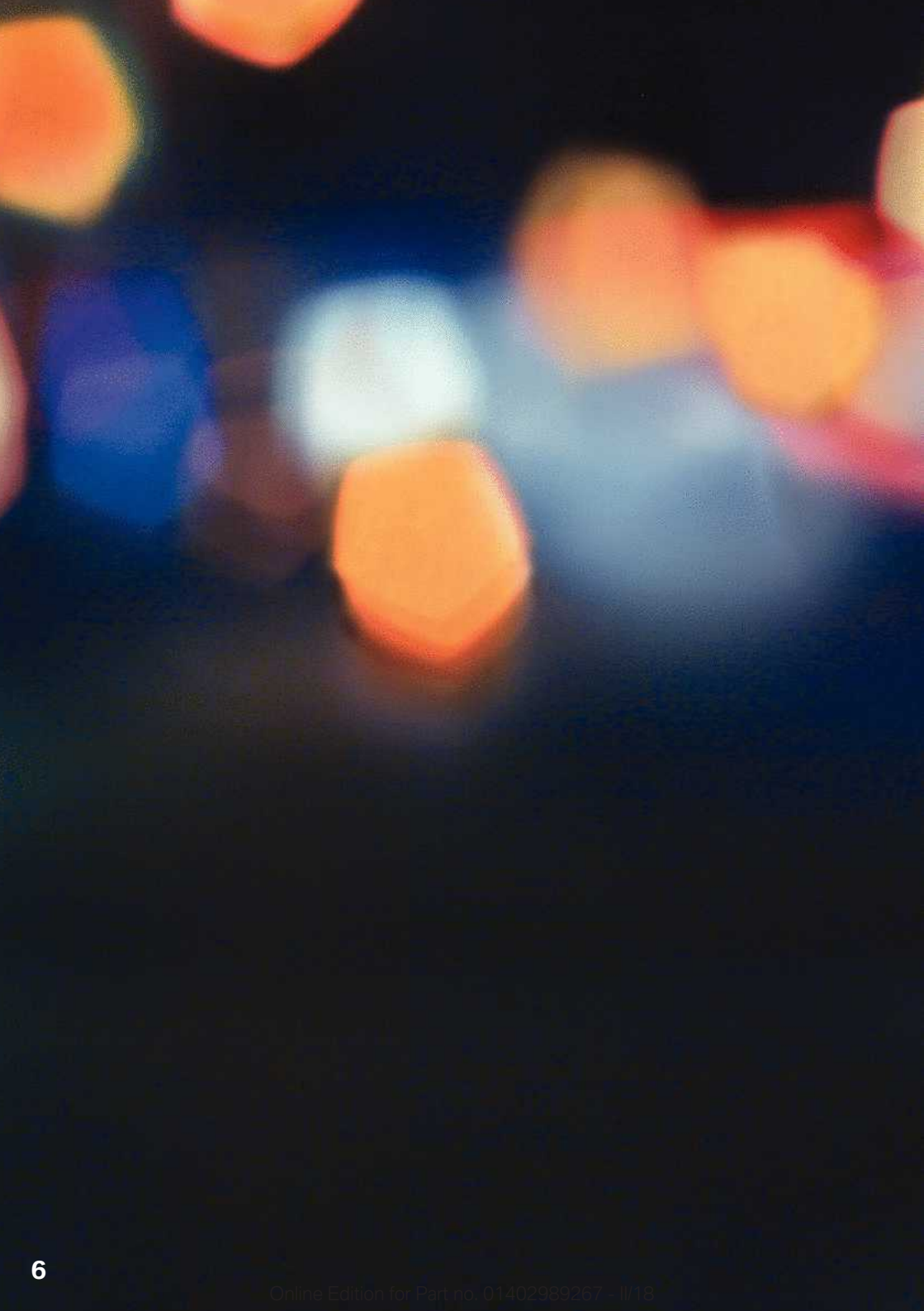



! NOTES

Information	8
-------------------	---

Information

Using this Owner's Manual

Orientation

The fastest way to find information on a particular topic is by using the index.

An initial overview of the vehicle is provided in the first chapter.

Updates made after the editorial deadline

Due to updates after the editorial deadline, differences may exist between the printed Owner's Manual and the following Owner's Manuals:

- ▶ Integrated Owner's Manual in the vehicle.
- ▶ Online Owner's Manual.
- ▶ BMW i Driver's Guide app.

Notes on updates can be found in the appendix of the printed Owner's Manual for the vehicle.

Owner's Manual for Navigation, Entertainment, Communication

The Owner's Manual for Navigation, Entertainment, and Communication can be obtained as printed book from the service center.

The topics of Navigation, Entertainment, and Communication can be called up via the following Owner's Manuals:

- ▶ Integrated Owner's Manual in the vehicle.
- ▶ Online Owner's Manual.
- ▶ BMW i Driver's Guide app.

Additional sources of information

Dealer's service center

A dealer's service center will be glad to answer questions at any time.

Internet

The Owner's Manual and general information on BMW, for example on technology, are available on the Internet: www.bmwusa.com.

Integrated Owner's Manual in the vehicle

The Integrated Owner's Manual specifically describes features and functions found in the vehicle. The Integrated Owner's Manual can be displayed on the Control Display. Additional information, refer to page 59.

BMW i Driver's Guide App



The BMW i Driver's Guide app specifically describes features and functions found in the vehicle. The app can be displayed on smartphones and tablets. Additional information, refer to page 60.

Online Owner's Manual

The Online Owner's Manual specifically describes features and functions found in the vehicle. The Online Owner's Manual can be displayed in any of today's browsers. Additional information, refer to page 61.

Symbols and displays

Symbols in the Owner's Manual

Symbol	Meaning
	Precautions that must be followed in order to avoid the possibility of injury to yourself and to others as well as serious damage to the vehicle.
	Measures that can be taken to help protect the environment.
"..."	Texts in vehicle used to select individual functions.
>...<	Verbal instructions to use with the voice activation system.
>>...<<	Answers generated by the voice activation system.

Action steps

Action steps to be carried out are presented as numbered list. The steps must be carried out in the defined order.

1. First action step.
2. Second action step.

Enumerations

Enumerations without mandatory order or alternative possibilities are presented as list with bullet points.

- ▷ First possibility.
- ▷ Second possibility.

Symbols on vehicle components

 This symbol on a vehicle component indicates that further information on the component is available in the Owner's Manual.

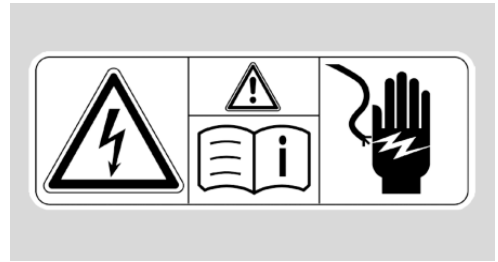

The symbols on parts of the vehicle indicate that incorrect use of high-voltage equipment or of orange-colored high-voltage components results in the risk of life-threatening injury from electric shock.

Vehicle features and options

This Owner's Manual describes all models and all standard, country-specific and optional equipment that is offered in the model series. Therefore, this Owner's Manual also describes and illustrates features and functions that are not available in your vehicle, for example because of the selected optional features or the country-specific version.

This also applies to safety-related functions and systems.

When using these functions and systems, the applicable laws and regulations must be observed.

Your dealer's service center is happy to answer any questions that you may have about the features and options applicable to your vehicle.

Status of the Owner's Manual

Basic information

The manufacturer of your vehicle pursues a policy of constant development that is conceived to ensure that our vehicles continue to embody the highest quality and safety standards. In rare cases, therefore, the features described in this

Owner's Manual may differ from those in your vehicle.

Updates made after the editorial deadline

Due to updates after the editorial deadline, differences may exist between the printed Owner's Manual and the following Owner's Manuals:

- ▶ Integrated Owner's Manual in the vehicle.
- ▶ Online Owner's Manual.
- ▶ BMW i Driver's Guide app.

Notes on updates can be found in the appendix of the printed Owner's Manual for the vehicle.

For Your Own Safety

Intended use

Follow the following when using the vehicle:

- ▶ Owner's Manual.
- ▶ Information on the vehicle. Do not remove stickers.
- ▶ Technical vehicle data.
- ▶ The traffic, speed, and safety laws where the vehicle is driven.
- ▶ Vehicle documents and statutory documents.

Warranty

Your vehicle is technically configured for the operating conditions and registration requirements applying in the country of first delivery, also known as homologation. If your vehicle is to be operated in a different country it might be necessary to adapt your vehicle to potentially differing operating conditions and registration requirements. If your vehicle does not comply with the homologation requirements in a certain country you may not be able to lodge warranty claims for your vehicle there. Further information on warranty is available from a dealer's service center.

Working on the vehicle, maintenance and repairs

Advanced technology, especially the use of high-performance high-voltage electronics and modern materials such as carbon, requires special knowledge when making modifications to and working on the vehicle, as well as customized maintenance and repair work.

The manufacturer of your vehicle recommends having changes to and work on the vehicle, especially maintenance and repair of the high-voltage system and the carbon body as well as retrofitting of accessories, done by an authorized BMW i dealer's service center. If you choose to use another service facility, BMW recommends use of a facility that performs work, for instance maintenance and repair, according to BMW i specifications with properly trained personnel, referred to in this Owner's Manual as "another qualified service center or repair shop".

DANGER

Improperly executed work, in particular maintenance and repair on the high-voltage system and the carbon body as well as accessories retrofits, can lead to electric shock. There is a risk of injury, fire and danger to life. The manufacturer of your vehicle recommends that the work on the vehicle, in particular maintenance and repair, be performed only by an authorized BMW i dealer's service center or another qualified service center or repair shop.

Parts and accessories

BMW recommends the use of parts and accessory products approved by BMW.

Approved parts and accessories, and advice on their use and installation are available from a BMW dealer's service center.

BMW parts and accessories have been tested by BMW for their safety and suitability in BMW vehicles.

BMW warrants genuine BMW parts and accessories.

BMW does not evaluate whether each individual product from another manufacturer can be used with BMW vehicles without presenting a safety hazard, even if a country-specific official approval was issued. BMW does not evaluate whether these products are suitable for BMW vehicles under all usage conditions.

California Proposition 65 Warning

California law requires vehicle manufacturers provide the following warning:

WARNING

Engine exhaust and a wide variety of Automobile components and parts, including components found in the interior furnishings in a vehicle, contain or emit chemicals known to the State of California to cause cancer and birth defects and reproductive harm. In addition, certain fluids contained in vehicles and certain products of component wear contain or emit chemicals known to the State of California to cause cancer and birth defects or other reproductive harm. Battery posts, terminals and related accessories contain lead and lead compounds. Batteries also contain other chemicals known to the State of California to cause cancer. Wash your hands after handling. Used engine oil contains chemicals that have caused cancer in laboratory animals. Always protect your skin by washing thoroughly with soap and water. For more information go to www.P65Warnings.ca.gov/passenger-vehicle.

WARNING

Operating, servicing and maintaining a passenger vehicle or off-highway motor vehicle can expose you to chemicals including engine exhaust, carbon monoxide, phthalates, and lead, which are known to the State of California to cause cancer and birth defects or other repro-

ductive harm. To minimize exposure, avoid breathing exhaust, do not idle the engine except as necessary, service your vehicle in a well-ventilated area and wear gloves or wash your hands frequently when servicing your vehicle. For more information go to www.P65Warnings.ca.gov/passenger-vehicle.

Service and warranty

We recommend that you read this publication thoroughly. Your vehicle is covered by the following warranties:

- ▷ New Vehicle Limited Warranty.
- ▷ Rust Perforation Limited Warranty.
- ▷ Federal Emissions System Defect Warranty.
- ▷ Federal Emissions Performance Warranty.
- ▷ California Emission Control System Limited Warranty.

Detailed information about these warranties is listed in the Service and Warranty Information Booklet for US models or in the Warranty and Service Guide Booklet for Canadian models.

Your vehicle has been specifically adapted and designed to meet the particular operating conditions and homologation requirements in your country and continental region in order to deliver the full driving pleasure while the vehicle is operated under those conditions. If you wish to operate your vehicle in another country or region, you may be required to adapt your vehicle to meet different prevailing operating conditions and homologation requirements. You should also be aware of any applicable warranty limitations or exclusions for such country or region. In such case, please contact Customer Relations for further information.

Maintenance

Maintain the vehicle regularly to sustain the road safety, operational reliability and the New Vehicle Limited Warranty.

Specifications for required maintenance measures:

- ▶ BMW Maintenance system.
- ▶ Service and Warranty Information Booklet for US models.
- ▶ Warranty and Service Guide Booklet for Canadian models.

If the vehicle is not maintained according to these specifications, this could result in serious damage to the vehicle. Such damage is not covered by the BMW New Vehicle Limited Warranty.

Data memory

General information

Electronic control devices are installed in the vehicle. Some of these are necessary for the vehicle to function safely or provide assistance during driving, for instance driver assistance systems. Furthermore, control devices facilitate comfort or infotainment functions.

Electronic control devices contain data memories, which are able to temporarily or permanently store information about the condition of the vehicle, component load, maintenance requirements, technical events or faults.

This information generally records the state of a component, a module, a system or the environment, for instance:

- ▶ Operating states of system components, e.g., fill levels, tire inflation pressure, battery status.
- ▶ Status messages for the vehicle and its individual components, e.g., wheel rotational speed, wheel speed, deceleration, transverse acceleration, engaged safety belt indicator.
- ▶ Malfunctions and faults in important system components, for instance lights and brakes.
- ▶ Information on vehicle-damaging events.
- ▶ Responses by the vehicle to special situations such as airbag deployment or engagement of the stability control systems.
- ▶ Ambient conditions, e.g., temperature, rain sensor signals.

The data is required to perform the control device functions. Furthermore, it also serves to recognize and correct malfunctions, and helps the vehicle manufacturer to optimize vehicle functions. The majority of this data is transient and is only processed within the vehicle itself. Only a small proportion of the data is stored in event or fault memories and, if needed, in the vehicle key.

Reading out data

When servicing, for instance during repairs, service processes, warranty cases, and quality assurance measures, this technical information can be read out from the vehicle together with the vehicle identification number. A dealer's service center or another qualified service center or repair shop can read out the information. The socket for OBD Onboard Diagnosis required by law in the vehicle is used to read out the data. The data is collected, processed, and used by the relevant organizations in the service network. The data documents the technical conditions of the vehicle, helps in locating faults and improving quality, and is transferred to the vehicle manufacturer, if needed.

Furthermore, the manufacturer has product monitoring duties to meet in line with product liability law. To fulfill these duties, the vehicle manufacturer needs technical data from the vehicle. Fault and event memories in the vehicle can be reset when a dealer's service center or another qualified service center or repair shop performs repair or servicing work.

Data on the scope of servicing work performed and maintenance records are stored in the vehicle by means of the service history and transferred to the vehicle manufacturer. The vehicle owner can contact a dealer's service center to object to the data being stored and transferred to the vehicle manufacturer. This objection applies for as long as the vehicle owner remains the proprietor of the vehicle.

Data entry and data transfer into the vehicle

General information

Depending on the vehicle equipment, some data can be transferred into the vehicle when using comfort and infotainment functions, for instance:

- ▶ Multimedia data such as music or movies for playback in an integrated multimedia system.
- ▶ Address book data for use in conjunction with an integrated hands-free system or an integrated navigation system.
- ▶ Entered navigation destinations.
- ▶ Data on the use of Internet services.

This data can be stored locally in the vehicle or is found on a device that has been connected to the vehicle, e.g., a smartphone, USB stick or MP3 player. If this data is stored in the vehicle, it can be deleted at any time. This data is only transmitted to third parties if expressly desired. This depends on the personal settings selected for using online services.

Depending on the vehicle equipment, the following comfort and individual settings can be stored in the vehicle and modified at any time, for instance:

- ▶ Settings for the seat and steering wheel positions.
- ▶ Suspension and climate control settings.
- ▶ Individual settings, for instance lighting in the car's interior.

Control via mobile devices

Depending on the vehicle equipment, mobile devices connected to the vehicle, for instance smartphones, can be controlled via the vehicle control elements. The sound and picture from the mobile device can be played back and displayed through the multimedia system. Certain information is transferred to the mobile device at the same time. Depending on the type of connection, this includes, for instance position data and other general vehicle information. This opti-

mizes the way in which selected apps, for instance navigation or music playback, work.

There is no further interaction between the mobile device and the vehicle, for instance active access to vehicle data. How the data will be processed further is determined by the provider of the particular app being used. The extent of the possible settings depends on the respective app and the operating system of the mobile device.

Services

General information

If the vehicle has a wireless network connection, this enables data to be exchanged between the vehicle and other systems. The wireless network connection is realized via an in-vehicle transmitter and receiver unit or via personal mobile devices brought into the vehicle, for instance smartphones. This wireless network connection enables 'online functions' to be used. These include online services and apps supplied by the vehicle manufacturer or by other providers.

Services from the vehicle manufacturer

Where online services from the vehicle manufacturer are concerned, the corresponding functions are described in the appropriate place, for instance the Owner's Manual or manufacturer's website. The relevant legal information pertaining to data protection is provided there too. Personal data may be used to perform online services. Data is exchanged over a secure connection, for instance with the IT systems of the vehicle manufacturer intended for this purpose. Any collection, processing, and use of personal data above and beyond that needed to provide the services must always be based on a legal permission, contractual arrangement or consent.

In addition, the vehicle manufacturer evaluates anonymized information on transport infrastructure and how the infotainment system is used. This information cannot be traced back to individual vehicles or people. Evaluating the data en-

ables the manufacturer to further improve its products or services, for instance by incorporating the most up-to-date traffic bulletins. The data transfer feature can be deactivated in the vehicle. Certain services and functions, some of which are subject to a charge, can be deactivated by the driver. It is also possible to activate or deactivate the data connection as a whole. That is, with the exception of functions and services required by law such as Assist systems.

Services from other providers

When using online services from other providers, these services are the responsibility of the relevant provider and subject to their data privacy conditions and terms of use. The vehicle manufacturer has no influence on the content exchanged during this process. Information on the way in which personal data is collected and used in relation to services from third parties, the scope of such data, and its purpose, can be obtained from the relevant service provider.

Event Data Recorder EDR

This vehicle is equipped with an event data recorder EDR. The main purpose of an EDR is to record, in certain crash or near crash-like situations, such as an air bag deployment or hitting a road obstacle, data that will assist in understanding how a vehicle's systems performed. The EDR is designed to record data related to vehicle dynamics and safety systems for a short period of time, typically 30 seconds or less.

The EDR in this vehicle is designed to record such data as:

- ▶ How various systems in your vehicle were operating.
- ▶ Whether or not the driver and passenger safety belts were fastened.
- ▶ How far, if at all, the driver was depressing the accelerator and/or brake pedal.
- ▶ How fast the vehicle was traveling.

This data can help provide a better understanding of the circumstances in which crashes and injuries occur.

EDR data is recorded by your vehicle only if a nontrivial crash situation occurs; no data is recorded by the EDR under normal driving conditions and no personal data, for instance name, gender, age, and crash location, are recorded.

However, other parties, such as law enforcement, could combine the EDR data with the type of personally identifying data routinely acquired during a crash investigation.

To read data recorded by an EDR, special equipment is required, and access to the vehicle or the EDR is needed. In addition to the vehicle manufacturer, other parties, such as law enforcement, that have the special equipment, can read the information if they have access to the vehicle or the EDR.

Vehicle identification number

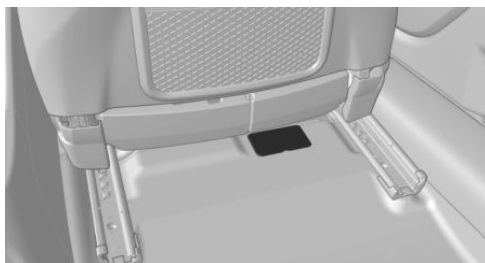

The vehicle identification number can be found under a cover under the front passenger seat.

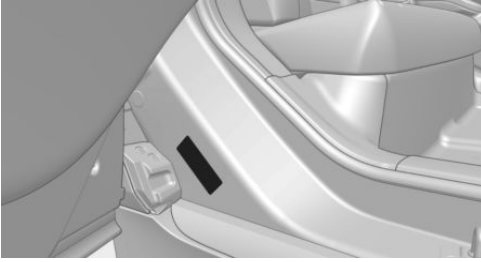

The vehicle identification number can also be found on the type label on the rear right door frame.

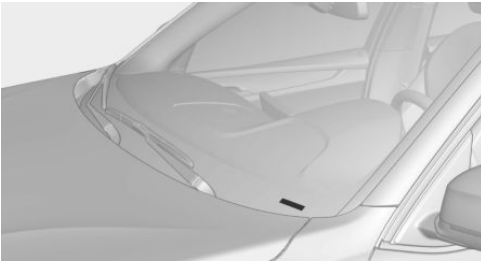

The vehicle identification number can also be found behind the windshield.

Reporting safety defects

For US customers

The following only applies to vehicles owned and operated in the US.

If you believe that your vehicle has a defect which could cause a crash or could cause injury or death, you should immediately inform the National Highway Traffic Safety Administration NHTSA, in addition to notifying BMW of North America, LLC, P.O. Box 1227, Westwood, New Jersey 07675-1227, Telephone 1-800-831-1117.

If NHTSA receives similar complaints, it may open an investigation, and if it finds that a safety defect exists in a group of vehicles, it may order a recall and remedy campaign.

However, NHTSA cannot become involved in individual problems between you, your dealer, or BMW of North America, LLC.

To contact NHTSA, you may call the Vehicle Safety Hotline toll-free at 1-888-327-4236 (TTY: 1-800-424-9153); go to <http://www.safercar.gov>; or write to: Administrator, NHTSA, 400 Seventh Street, SW., Washington, DC 20590. You can also obtain other information about motor vehicle safety from <http://www.safercar.gov>.

For Canadian customers

Canadian customers who wish to report a safety-related defect to Transport Canada, Defect Investigations and Recalls, may call the toll-free hotline 1-800-333-0510. You can also obtain other information about motor vehicle safety from <http://www.tc.gc.ca/roadsafety>.





◀ QUICK REFERENCE

Your BMW i at a glance 18

Your BMW i at a glance

Opening and closing

Buttons on the remote control



- 1 Unlocking
- 2 Locking
- 3 Unlocking the tailgate
- 4 Panic mode

Unlocking the vehicle

 Press button on the remote control.

Depending on the settings, either only the driver's door or all vehicle access points are unlocked.

If only the driver's door is unlocked, press the button of the remote control again to unlock the other vehicle access points.

 Press and hold this button on the remote control after unlocking.

The windows and the glass sunroof are opened, as long as the button on the remote control is pressed.

Locking the vehicle

 Press button on the remote control.

All vehicle access points are locked.

Buttons for the central locking system

Overview



Buttons for the central locking system.

Locking



Press the button with the doors closed.

Unlocking



Press button.

The vehicle locks automatically after you drive off.

Panic mode

You can trigger the alarm system if you find yourself in a dangerous situation.



Press button on the remote control for at least 3 seconds.

To switch off the alarm: press any button.

Comfort Access

Concept

The vehicle can be accessed without activating the remote control.

All you need to do is to have the remote control with you, such as in your pants pocket.

The vehicle automatically detects the remote control when it is in close proximity or in the car's interior.

Unlocking the vehicle



Grasp the door handle on the driver's or front passenger door completely.

Locking the vehicle

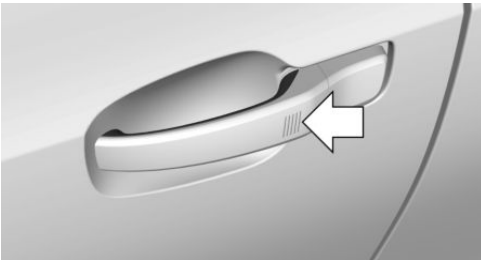

Touch the surface on the door handle of the driver's or front passenger door with your finger for approx. 1 second without grasping the door handle.

Unlocking the tailgate

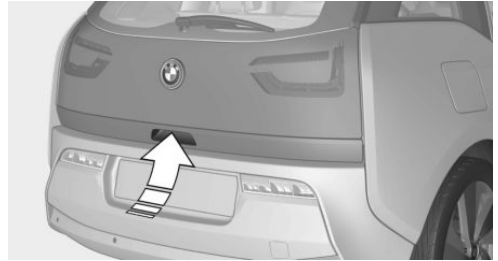

- ▶ Unlock the vehicle and press the button on the tailgate.
- ▶ If carrying the remote control, press the button on the tailgate.
- ▶  Press button on the remote control for approx. 1 second.

Depending on the setting, the doors may also be unlocked.

Seats, mirrors, and steering wheel

Manually adjustable seats



- 1 Forward/backward
- 2 Height
- 3 Backrest tilt

Adjusting the exterior mirrors



- 1 Settings
- 2 Selecting a mirror, Automatic Curb Monitor, automatic cornering adjustment
- 3 Folding in and out

Adjusting the steering wheel

Manual steering wheel adjustment

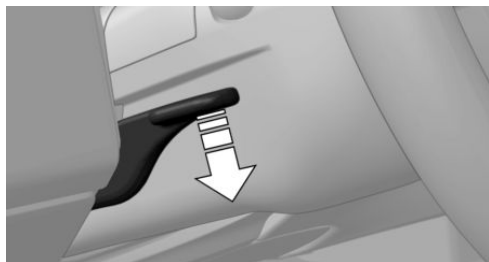

1. Fold the lever down.
2. Adjust the height and reach of the steering wheel.
3. Fold the lever back up.

Displays and control elements

In the vicinity of the steering wheel



- 1 Light switch element
- 2 Turn signal indicator, high beams
- 3 Instrument cluster
- 4 Start/Stop button
- 5 Wipers

Indicator/warning lights

Instrument cluster

The indicator/warning lights can light up in a variety of combinations and colors.

Several of the lights are checked for proper functioning and light up temporarily when drive-ready state is established.

Driver's door

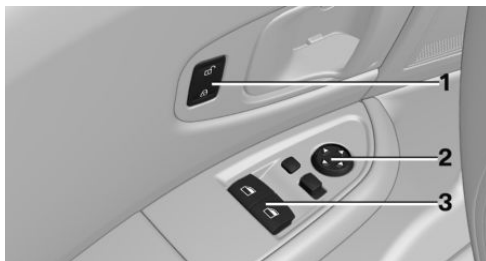

- 1 Locking/unlocking the vehicle
- 2 Exterior mirrors
- 3 Power windows

All around the iDrive Controller

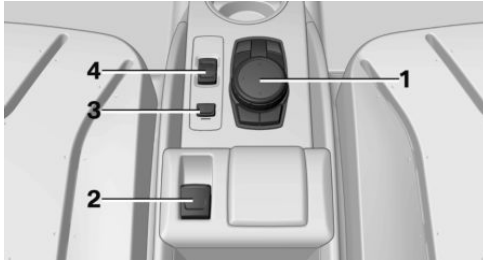

- 1 Controller
- 2 Parking brake
- 3 Parking assistance systems
- 4 Driving Dynamics Control

All around the selector lever

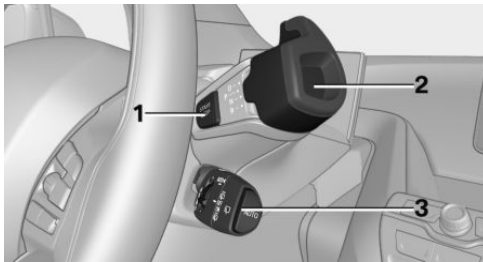

- 1 Start/Stop button
- 2 Selector lever
- 3 Wipers

iDrive

Concept







The iDrive combines the functions of many switches. These functions can be operated via the Controller.

Controller

General information

The buttons can be used to open the menus directly. The Controller can be used to select menu items and enter the settings.

Buttons on the Controller

Button	Function
	Press once: call up main menu. Press twice: display all menu items of the main menu.
	Open the Communication menu.
	Open the Media/Radio menu.
	Open destination input menu for navigation.
	Open navigation map.
	Press once: open the previous display. Press and hold: open the menus used last.
	Open the Options menu.

Voice activation

Using the voice activation system

Activating the voice activation system

1.  Press button on the steering wheel.
2. Wait for the signal.
3. Say the command.

 This symbol in the instrument cluster indicates that the voice activation system is active.

If no other commands are possible, operate the function via iDrive.

Terminating the voice activation system

 Press the button on the steering wheel or ›Cancel‹.

Help on the voice activation system

- ▶ To have information on the operating principle of the voice activation system read out loud: ›General information on voice control‹.
- ▶ To have help for the current menu read out loud: ›Help‹.

Information on Emergency Requests

Do not use the voice activation system to initiate an Emergency Request. In stressful situations, the voice and vocal pitch can change. This can unnecessarily delay the establishment of a phone connection.

Instead, use the SOS button close to the interior mirror.

Driving

Drive-ready state

General information

When drive-ready state is switched on, the vehicle is operational.

All vehicle systems are ready for operation.

Most of the indicator/warning lights in the instrument cluster light up for a varied length of time.

Activated drive-ready state is the equivalent of a running engine in conventional vehicles. Deactivated drive-ready state is equivalent to switching the ignition off.

To save battery power when parking, switch off drive-ready state and any unnecessary electronic systems/power consumers.

Drive-ready state is switched off automatically:

- ▶ When you lock the vehicle while low beams are switched on.

- ▶ If the charge state of the batteries is low.
- ▶ When opening or closing the driver door, if the driver's safety belt is unbuckled and the low beams are switched off.
- ▶ While the driver's safety belt is unbuckled with driver's door open and low beams off.

After the driver's door is opened or closed or the driver's safety belt is released, the radio-ready state remains active.

Start/Stop button



Pressing the Start/Stop button switches standby state on or off.

Drive-ready state is switched on when you depress the brake pedal while pressing the Start/

Stop button.

Switching on drive-ready state

1. Close the driver's door.
2. Depress the brake pedal.
3. Press the Start/Stop button.

Drive-ready state is switched on.

Displays



READY indicates drive-ready state.

When drive-ready state is switched on, the light on the Start/Stop button lights up blue.

In addition, a signal sounds.

Drive-ready state in detail

Requirements

Driving is possible under the following conditions:

- ▶ The high-voltage battery is sufficiently charged.
- ▶ The driver's door is closed.

Driving away

1. Switch on drive-ready state.
2. Apply the brake and engage the selector lever in position D or R.
3. Release the parking brake.
4. Depress the accelerator pedal to drive off.

Accelerator pedal positions

Engaging the gear

- ▶ Interlock: the selector lever position P can be exited only with drive-ready state engaged.
- ▶ Shift lock: with the vehicle stationary, press on the brake pedal before shifting out of P or N; otherwise, the shift command will not be executed.
- ▶ Shift lock: before shifting out of P, remove the charging cable from the vehicle; otherwise, the shift command will not be executed.

Engaging N, D, R

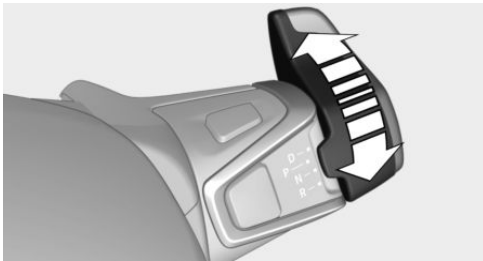

Turn the selector lever in the desired direction. The selected gear is displayed on the selector lever.

Engaging P

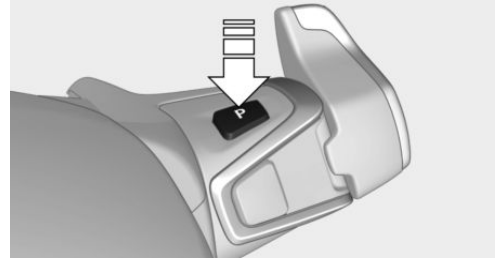

Apply brake and press button P.

Parking brake

Setting



Pull the switch.

The LED and indicator light light up.

Releasing



With drive-ready state switched on:

Press the switch while pressing on the brake pedal.

The LED and indicator light go out.

The parking brake is released.

High beams, headlight flasher, turn signal, roadside parking light

High beams, headlight flasher

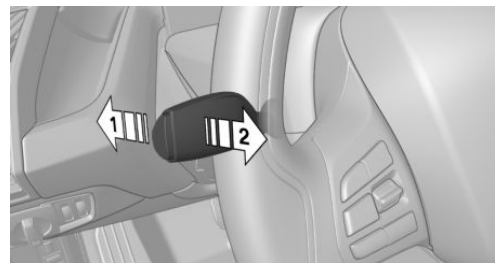

Push the lever forward or pull it backward.

- ▶ High beams, arrow 1.
- ▶ Headlight flasher, arrow 2.

Turn signal

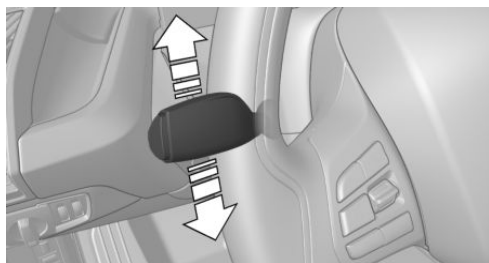

- ▷ On: press the lever past the resistance point.
- ▷ Off: lightly tap the lever to the resistance point.
- ▷ Triple turn signal activation: lightly tap the lever up or down.
- ▷ Brief signaling: press the lever to the resistance point and hold it there for as long as you want the turn signal to flash.

Roadside parking light

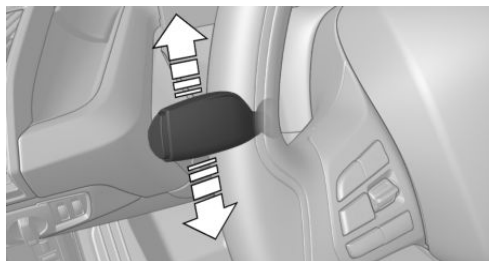





Illuminate the vehicle on one side.

- ▷ On: with standby state switched off, press the lever either up or down past the resistance point for approx. 2 seconds.
- ▷ Off: briefly press the lever to the resistance point in the opposite direction.

Lights and lighting

Light functions

Symbol	Function
	Automatic headlight control.
	Lights off. Daytime running lights.
	Parking lights.
	Low beams.
	Instrument lighting.

Washer/wiper system

Switching the wipers on/off and brief wipe

Switching on

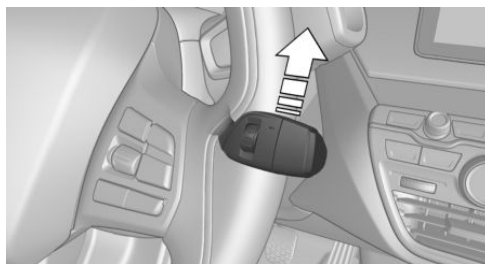

- ▷ Normal wiper speed: tap up once.
- ▷ Fast wiper speed: tap up twice or tap once beyond the resistance point.

Brief wipe and switching off

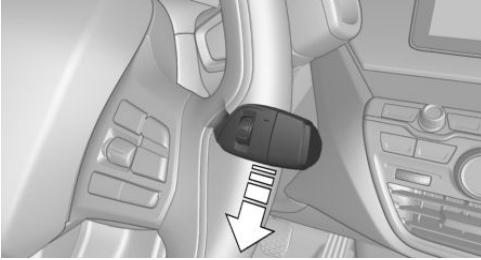

Push wiper lever down.

- ▶ Brief wipe: press down once.
- ▶ To switch off normal wipe: press down once.
- ▶ To switch off fast wipe: press down twice.

Rain sensor

Activating/deactivating

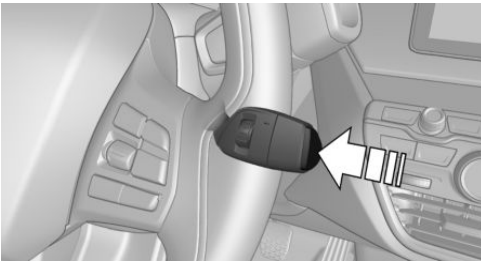

Press button on the wiper lever.

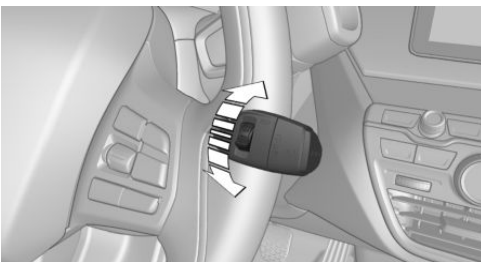

Adjusting the sensitivity:

Turn the thumbwheel on the wiper lever.



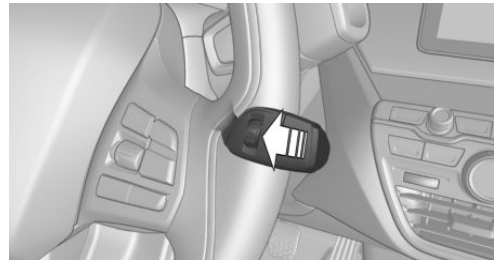





Cleaning the windshield













Pull the wiper lever towards you.

Climate control

Air conditioner

Button	Function
	Temperature.
	Air conditioning.
	Recirculated-air mode.
	Control the air flow, manual.
	Air distribution: windows.
	Air distribution: upper body region.
	Air distribution: floor area.
	Defrost and defog the windows.
	Rear window defroster.

Automatic climate control

Button	Function
	Temperature.
	Air conditioning.
	Maximum cooling.
	AUTO program.
	Automatic recirculated-air control AUC/recirculated-air mode.
	Control the air flow, manual.
	Control the manual air distribution.
	SYNC program.
	Defrost and defog the window.
	Rear window defroster.

Infotainment

Radio

Control elements

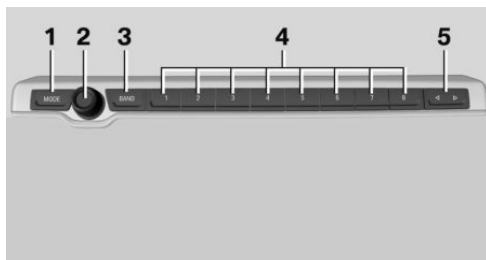

- 1 Changing the entertainment source
- 2 Sound output on/off, volume
- 3 Changing the waveband
- 4 Programmable memory buttons
- 5 Change station/track

Navigation destination entry

Entering a destination via address

State/province

1. "Navigation"
2.  "Enter address"
3. "State/Province?"
4. Move the Controller to the right to select the state from the list.

Entering the address

The address can be entered in any order.

Example: entering the address via the town/city

1. "City/Postal code?"
2. Enter the town/city.
The list is narrowed down further with each entry.
3. **OK** Select the symbol.

4. Select a town/city from the list.
5. If necessary, enter the street.
6. Select the street as you would the town/city.
7. If necessary, enter a house number.
8. **OK** Select the symbol.
9. Select a house number or range of house numbers from the list.

Starting destination guidance

"Start guidance"

If only the town/city was entered: destination guidance is started to the town/city center.

Connecting a mobile phone

After the mobile phone is connected once to the vehicle, the mobile phone can be operated using iDrive, the steering wheel buttons and spoken instructions.

1. "My Vehicle"
2. "iDrive settings"
3. "Mobile devices"
4. "Connect new device"
5. Select the functions for which the mobile phone is to be used.

The Bluetooth name of the vehicle is displayed on the Control Display.

6. To perform additional steps on the mobile phone, refer to the mobile phone owner's manual: e.g., search for or connect the Bluetooth device or a new device.

The Bluetooth name of the vehicle appears on the mobile phone display. Select the Bluetooth name of the vehicle.

7. Depending on the mobile device, a control number is displayed or the control number must be entered.
 - ▶ Compare the control number displayed on the Control Display with the control number on the display of the device.

Confirm the control number on the device and on the Control Display.

- ▶ Enter and confirm the same control number on the device and via iDrive.

The device is connected and displayed in the device list.

The mobile phone is connected and will appear at the top of the list of mobile phones.

Using the phone

Accepting a call

Incoming call can be accepted via iDrive or the button on the steering wheel.

Via iDrive

 "Accept"

Via the button on the steering wheel



Press button.

Via the instrument cluster

Use the thumbwheel on the steering wheel to select: "Accept"

Dialing a number

1. "Communication"
2. "Dial number"
3. Enter the numbers.
4.  Select the symbol. The connection is established via the mobile phone to which this function has been assigned.

Charging and refueling the vehicle

Charging the vehicle

Connecting the charging cable

To connect, engage selector lever position P, deactivate drive-ready state, and unlock the vehicle. Set the parking brake, if needed.

1. Tap on the charging socket flap, arrow.



2. Remove the charging socket lid, arrow.

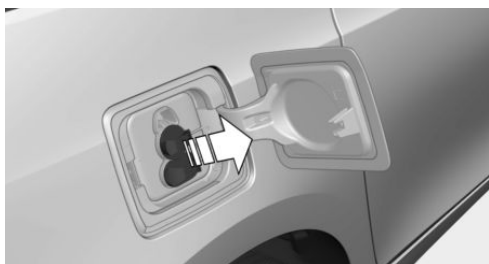

3. Remove cover of the charging cable plug, if needed.
4. Connect Level 1 charging cable to the household socket or Level 2 charging cable to the port on the charging station.
5. Insert the charging cable plug corresponding to the charging socket, and push it in until it engages.

Removing

When the charging process is active and the vehicle is locked, the charging cable is locked. Unlock the vehicle before removing the cable.

When the charging process is completed, the charging cable is automatically unlocked.

If necessary, clean the area between charging socket flap and charging socket, for instance from snow, before removing it.

1. Unlock the vehicle by remote control if it is locked.

Charging cable is unlocked.

2. Press the release button on the handle, arrow 1, and grasp the charging cable at the gripping areas.

Charging process is interrupted.

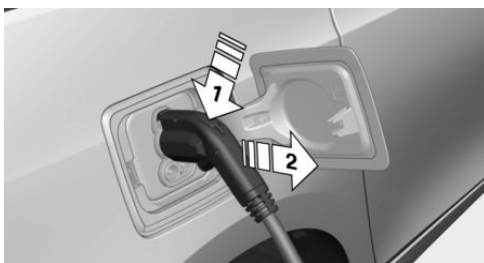

3. Remove the charging cable from the charging socket, arrow 2.
4. Put the charging socket lid back on.
5. Close the charging socket flap.
6. Attach cover of the charging cable plug, if needed.
7. Disconnect Level 1 charging cable from the household socket or Level 2 charging cable from the port on the charging station as needed.
8. Stow the charging cable.

At a charging station, insert the permanently installed charging cable in the place provided for it.

Always keep charging socket clean and unobstructed.

Keep the charging socket flap closed when the charging socket is not used.



Refueling

Tank venting

In the fuel tank, excess pressure can build up due to gasoline vapors which are dissipated before the fuel cap is opened.

The button is located on the driver's floor area.

1. Switch off drive-ready state.

2.  Press button to start the pressure equalization.

The status of the tank venting is displayed in the instrument cluster. In rare cases, the tank venting can last several minutes.

If the tank venting has been completed, a message is displayed in the instrument cluster. The fuel cap is released for opening.

3. Open the fuel filler flap.

If the fuel filler flap is not opened within 10 minutes after the fuel cap is released, the fuel filler flap relocks. Press button again.

Fuel cap

1. Press the rear edge of the fuel filler flap to open it.
2. Turn the fuel cap counterclockwise.
3. Place the fuel cap in the bracket attached to the fuel filler flap.

Gasoline

For the best fuel efficiency, the gasoline should be sulfur-free or very low in sulfur content.

Refuel only with unleaded gasoline without metallic additives.

Information on the recommended fuel grade can be found in the Owner's Manual.

Wheels and tires

Tire inflation pressure specifications

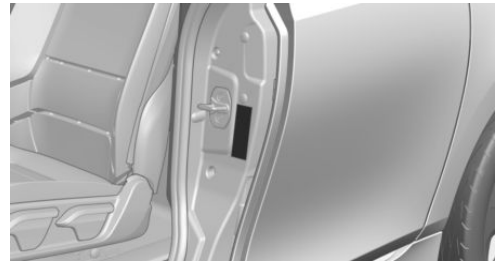

The pressure values for tire sizes approved by the manufacturer of the vehicle for the vehicle type are on the driver's side on the rear door.

After correcting the tire inflation pressure

Reinitialize the Flat Tire Monitor.

Reset the Tire Pressure Monitor.

Checking the tire inflation pressure

Regularly check the tire inflation pressure and correct it as needed:

- ▷ At least twice a month.
- ▷ Before embarking on an extended trip.

Check engine oil level with dipstick

1. Park the vehicle in a level and safe place with the Range Extender at operating temperature.
2. Switch the engine off.
3. Remove the cargo floor panel.
4. Turn the lid counterclockwise and remove.
5. After approx. 5, minutes, remove the dip stick and wipe with a lint-free cloth, paper towel or similar.
6. Carefully insert the dipstick up to the stop in the measuring tube, and pull it back out.

The engine oil level must be between the two marks of the dipstick.

Providing assistance

Hazard warning flashers



The button is located in the center console.

Breakdown assistance

Roadside Assistance

This service can be reached around the clock in many countries.

Roadside Assistance

Via iDrive:

1. "ConnectedDrive"
2. "BMW Assist"
3. "BMW i Roadside Assistance"

A voice connection is established with Roadside Assistance.

Warning triangle, first-aid kit

Warning triangle

The warning triangle is located in the hood.

First-aid kit

The first-aid kit is located in the trunk.

ConnectedDrive

Concierge service

The BMW Assist Concierge service offers information on events, gas stations or hotels, and

provides phone numbers and addresses. Many hotels can be booked directly by the BMW Concierge service. The Concierge service is part of the optional BMW Assist Response Center.

1. "ConnectedDrive"
2. "Concierge"

Teleservices

Teleservices are services that help to maintain vehicle mobility.

Depending on the equipment version, Teleservices comprise the following services:

- ▷ Roadside Assistance.
- ▷ Service Request.
- ▷ Automatic Service Request.
- ▷ Teleservice Report.
- ▷ Teleservice Battery Guard.
- ▷ Your dealer's service center.





 AT A GLANCE

Cockpit	34
iDrive	38
Voice activation system	45
General settings	48
Owner's Manual media	59
BMW eDRIVE	63
Safety of the high-voltage system	66

Cockpit

Vehicle features and options

This chapter describes all standard, country-specific and optional features offered with the series. It also describes features that are not necessarily

available in your vehicle, e. g., due to the selected options or country versions. This also applies to safety-related functions and systems. When using these functions and systems, the applicable laws and regulations must be observed.

In the vicinity of the steering wheel

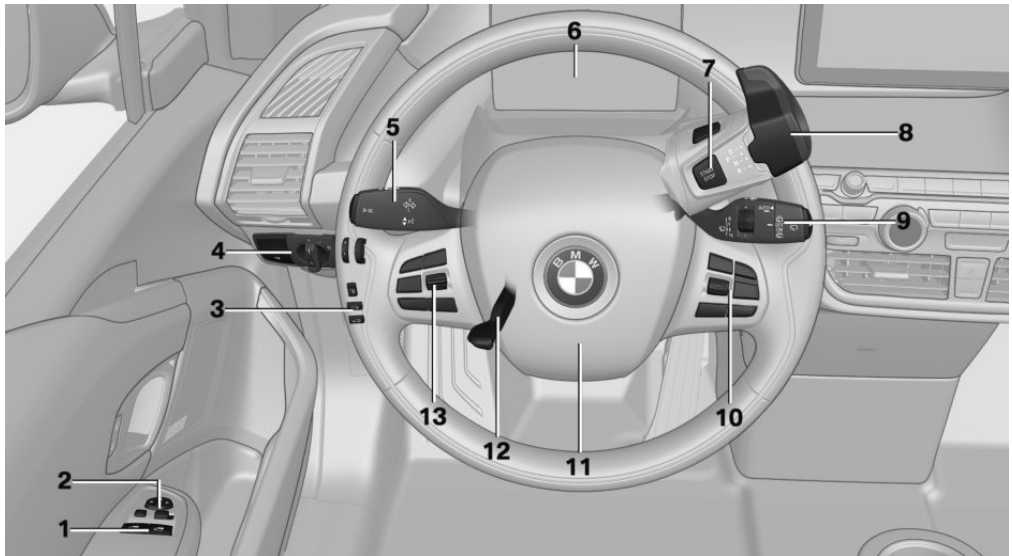

- 1 Power windows [84](#)
- 2 Exterior mirror operation [93](#)
- 3 Unlock hood [78](#)
Unlocking the tailgate [78](#)
With Range Extender: vent fuel tank [221](#)
- 4 Lights



Light switch [129](#)



Parking lights [129](#)



Low beams [129](#)























Automatic headlight control [130](#)

Daytime running lights [131](#)





Instrument lighting [131](#)

- 5 Left steering column stalk

-  Turn signal 109
-  High beams, headlight flasher 109
-  Roadside parking lights 129
-  Onboard Computer 126
- 6** Instrument cluster 114
- 7**  Switch drive-ready state on and off 100
- 8** Selector lever 102
- 9** Right steering column stalk
-  Wipers 109
-  Rain sensor 110
-  Clean the windshield and headlights 111
-  Rear window wiper in Canadian models 111
-  Rear window wiper 111
-  Clean the rear window 111
- 10** Steering wheel buttons, right
-  Entertainment source
-  Volume
-  Voice activation 45
-  Telephone
- Thumbwheel for selection lists 125
- 11**  Horn, entire surface
- 12** Adjust the steering wheel 95
- 13** Steering wheel buttons, left
-  Cruise control on/off, interrupt 159
-  Active Cruise Control on/off, interrupt 153
-  Cruise control: store speed
-  Cruise control: resume speed
-  Active Cruise Control, adjust distance
- Cruise control rocker switch

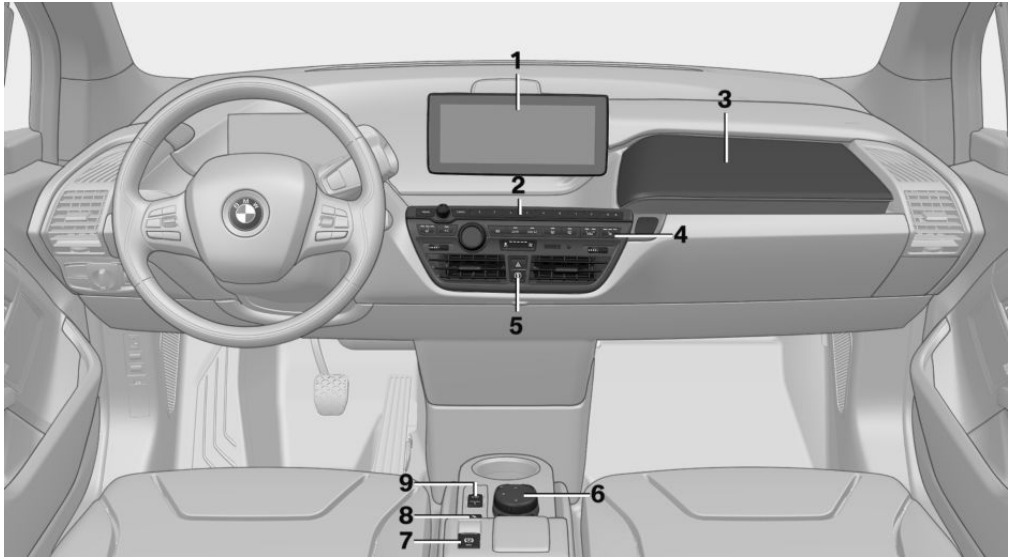
In the vicinity of the center console









- 1 Control Display [38](#)
- 2 Radio/multimedia, see Owner's Manual for Navigation, Entertainment, and Communication [8](#)
- 3 Glove compartment [191](#)
- 4 Climate control [172](#)
- 5  Hazard warning system [254](#)
- 6 Controller with buttons [39](#)
- 7 Parking brake [107](#)
- 8  PDC Park Distance Control [162](#)
Rearview camera [165](#)
Parking assistant [168](#)
- 9 Driving Dynamics Control [150](#)

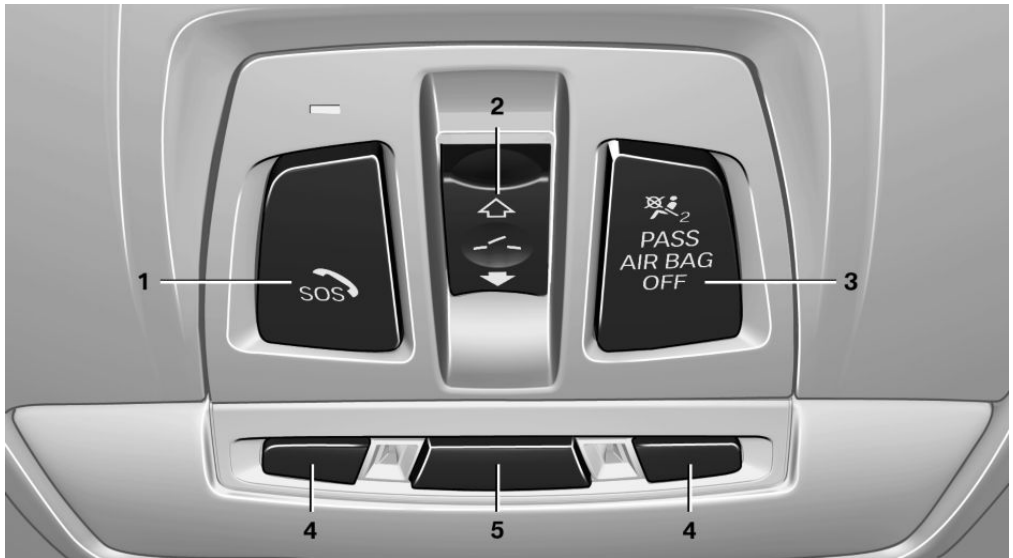

Intelligent Safety [141](#)

In the vicinity of the roofliner



- | | | | | | |
|---|---|--|---|---|-------------------------------------|
| 1 |  | Emergency Request, SOS 254 | 4 |  | Reading lights 131 |
| 2 |  | Glass sunroof, electric 85 | 5 |  | Interior lights 131 |
| 3 |  | Indicator light, front-seat passenger airbag 136 | | | |

iDrive

Vehicle features and options

This chapter describes all standard, country-specific and optional features offered with the series. It also describes features that are not necessarily available in your vehicle, e. g., due to the selected options or country versions. This also applies to safety-related functions and systems. When using these functions and systems, the applicable laws and regulations must be observed.

Concept

The iDrive combines the functions of many switches. These functions can be operated via the Controller.

Safety information

WARNING

Operating the integrated information systems and communication devices while driving can distract from traffic. It is possible to lose control of the vehicle. There is a risk of an accident. Only use the systems or devices when the traffic situation allows. As warranted, stop and use the systems and devices while the vehicle is stationary.

Control elements

Overview

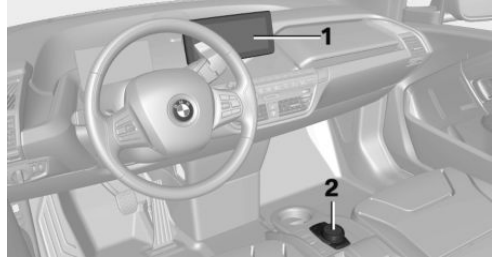

- 1 Control Display
- 2 Controller with buttons and, depending on the equipment version, with touchpad

Control Display

General information

To clean the Control Display, follow the care instructions, refer to page 261.

In the case of very high temperatures on the Control Display, for instance due to intense solar radiation, the brightness may be reduced down to complete deactivation. Once the temperature is reduced, for instance through shade or air conditioning, the normal functions are restored.

Safety information

NOTE

Objects in the area in the front of the Control Display can shift and damage the Control Display. There is a risk of damage to property. Do not place objects in the area in front of the Control Display.

Switching on/off automatically

The Control Display is switched on automatically after unlocking.

In certain situations, the Control Display is switched off automatically, for instance if no operation is performed on the vehicle for several minutes.

Switching on/off manually

The Control Display can also be switched off manually.

1.  Press button.

2. "Turn off control display"

Press the Controller or any button on the Controller to switch it back on again.

Controller

General information

The buttons can be used to open the menus directly. The Controller can be used to select menu items and enter the settings.

Some iDrive functions can be operated using the touchpad on the Controller, refer to page 41.

Operation

- ▶ Turn.

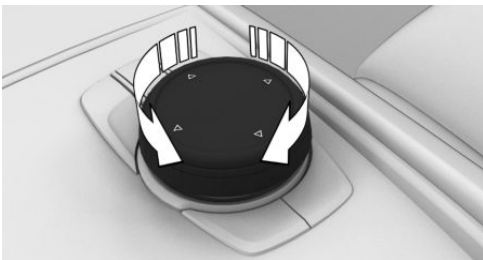



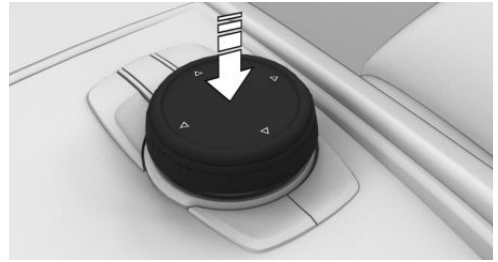

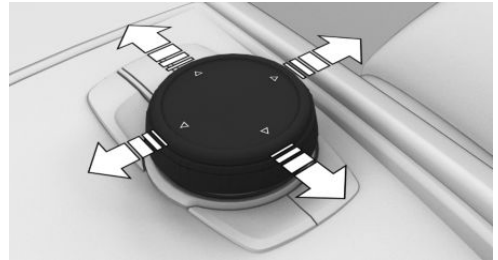

- ▶ Press.



- ▶ Move in four directions.



Buttons on the Controller

Button	Function
	Press once: call up main menu. Press twice: display all menu items of the main menu.
	Open the Communication menu.
	Open the Media/Radio menu.
	Open destination input menu for navigation.
	Open navigation map.
	Press once: open the previous display. Press and hold: open the menus used last.
	Open the Options menu.

Operating with the Controller

Opening the main menu

 Press button.

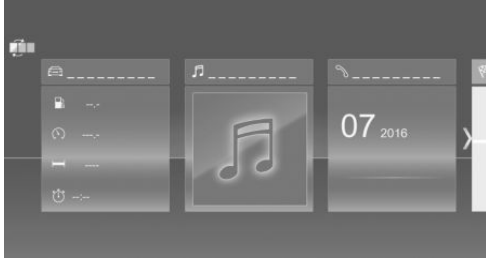

The main menu is displayed.

All iDrive functions can be called up via the main menu.

Adapting the main menu

-  Press the button twice.
All menu items of the main menu are displayed.
- Select a menu item.
- To move the menu item to the desired position, tilt the Controller to the right or left.

Selecting menu items

Highlighted menu items can be selected.

- Turn the Controller until the desired menu item is highlighted.

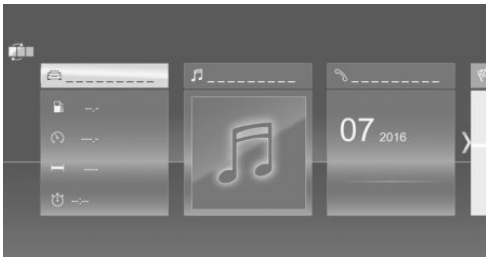

- Press the Controller.

Menu items in the Owner's Manual

In the Owner's Manual, menu items that can be selected are set in quotation marks, for instance "iDrive settings".

Changing between displays

After a menu item is selected, for instance "iDrive settings", a new display appears.

- ▶ Move the Controller to the left.
Closes the current display and shows the previous display.

- ▶  Press button.

The previous display opens.

- ▶ Move the Controller to the right.

New display is opened.

A white arrow indicates that additional displays can be called up.

Opening recently used menus

The recently used menus can be displayed.

- ▶  Press and hold this button.

Opening the Options menu

- ▶  Press button.

The "Options" menu is displayed.

The Options menu consists of various areas:

- ▶ Screen settings, for instance "Split screen".
- ▶ Control options for the selected main menu, for instance for "Media/Radio".
- ▶ If applicable, further operating options for the selected menu, for instance "Save station".

Changing settings

- Select a field.
- Turn the Controller until the desired setting is displayed.
- Press the Controller.

Activating/deactivating the functions

Several menu items are preceded by a checkbox. The checkbox indicates whether the function is activated or deactivated. Selecting the menu item activates or deactivates the function.

- Function is activated.
- Function is deactivated.

Entering letters and numbers



General information

Letters and numbers can be entered via the Controller.

The keyboard's display changes automatically.

Input

1. Turn the Controller: select letters or numbers.
2. **OK** : confirm entry.

Symbol	Function
	Press the Controller: delete letters or number.
	Hold the Controller down: delete all letters or numbers.

Switching between upper/lower case, numbers and characters

Depending on the menu, you can switch between entering upper and lower case, letters and numbers.

Symbol	Function
ABC	Enter the letters.
1@+	Enter the numbers.
abc or ABC	Change between capital and lower-case letters.

Entry comparison

When entering names and addresses, the choice is narrowed down with every letter entered and letters may be added automatically.

Entries are continuously compared with data stored in the vehicle.

- ▶ Only those letters are offered during entry for which data is available.
- ▶ Destination search: place names can be entered in all languages that are available in iDrive.

Using alphabetical lists

For alphabetical lists with more than 30 entries, the letters for which there is an entry are displayed at the left edge.

1. Turn the Controller to the left or right quickly. All letters for which there are entries are displayed on the left edge.
2. Select the first letter of the desired entry. The first entry of the selected letter is displayed.

Touchpad

General information

Some iDrive functions can be operated using the touchpad on the Controller.

Selecting functions

1. "My Vehicle"
2. "iDrive settings"
3. "Touchpad"
4. Select desired setting:
 - ▶ "Speller": enter letters and numbers.
 - ▶ "Map": using the map.
 - ▶ "Search fields": write letters without selecting the list field.

- ▶ "Audio feedback": pronounces entered letters and numbers.

Entering letters and numbers

Entering letters requires some practice at the beginning. When entering, pay attention to the following:

- ▶ The system distinguishes between upper and lower-case letters and numbers. To make entries, it may be necessary to change between upper and lower-case letters, numbers and characters, refer to page 41.
- ▶ Enter characters as they are displayed on the Control Display.
- ▶ Always enter associated characters, such as accents or periods so that the letter can be clearly recognized. The set language determines what input is possible. Where necessary, enter special characters via the Controller.
- ▶ To delete a character, swipe to the left on the touchpad.
- ▶ To enter a blank space, swipe to the right in the center of the touchpad.
- ▶ To enter a hyphen, swipe to the right in the upper area of the touchpad.
- ▶ To enter an underscore, swipe to the right in the lower area of the touchpad.

Using the map

The map in the navigation system can be moved via the touchpad.

Function	Operation
Move map.	Swipe in the appropriate direction.
Enlarge/shrink map.	Drag in or out on the touchpad with fingers.
Display menu.	Tap once.

Split screen

General information

Additional information can be displayed in several menus on the right side of the split screen, for instance information from the Onboard Computer.

In the divided screen view, the so-called split screen, this information remains visible even when switching to another menu.

Switching the split screen on/off

1.  Press button.
2. "Split screen"

Selecting the display

The display can be selected in menus, where the split screen is supported.

1. Move the Controller to the right until the split screen is selected.
2. Press the Controller.
3. Select the desired setting.

Specifying the number of displays

It is possible to specify the number of displays.

1. Move the Controller to the right until the split screen is selected.
2. Press the Controller.
3. "Personalize menu"
4. Select the desired setting.
5. Move the Controller to the left.

Status information

General information













The status field can be found in the upper area of the Control Display. Status information is displayed in the form of symbols.

Status field symbols





Radio

Symbol	Meaning
	HD Radio station is being received.





Telephone

Symbol	Meaning
	Incoming or outgoing call.
	Missed call.
	Signal strength of cellular network.
	Network search.
	Cellular network is not available.
	The critical charge state of the mobile phone has been reached.
	Roaming is active.
	SMS text message received.
	Message received.
	Reminder.
	Sending not possible.
	Contacts are loaded.

Entertainment

Symbol	Meaning
	Music collection.
	Bluetooth audio.
	USB audio interface.
	Online Entertainment.

Additional symbols

Symbol	Meaning
	Check Control message.
	The sound output has been switched off.
	Encrypted connection not active.
	Checking the current vehicle position.

Programmable memory buttons

General information

The iDrive functions can be stored on the programmable memory buttons and called up directly, for instance radio stations, navigation destinations, phone numbers and menu entries.

Settings are stored for the driver profile currently used.

Storing a function

1. Select function via iDrive.
2.  Press and hold the desired button until a signal sounds.

Running a function

- 1...8  Press button.

The function will work immediately. This means, for instance that the number is dialed when a phone number is selected.

Displaying the key assignment

Touch buttons with finger. Do not wear gloves or use objects.

The button assignment is displayed at the top edge of screen.

Deleting the button assignments

1. Press buttons 1 and 8 simultaneously for approx. 5 seconds.
2. "OK"

Voice activation system

Vehicle features and options

This chapter describes all standard, country-specific and optional features offered with the series. It also describes features that are not necessarily available in your vehicle, e. g., due to the selected options or country versions. This also applies to safety-related functions and systems. When using these functions and systems, the applicable laws and regulations must be observed.

Concept

Most functions displayed on the Control Display can be operated by voice commands via the voice activation system. The system supports you with announcements during input.

General information

- ▶ Functions that can only be used when the vehicle is stationary can only be operated via the voice activation system to a limited extent.
- ▶ The system uses a special microphone on the driver's side.
- ▶ ›...‹ in the Owner's Manual denotes verbal instructions to use with the voice activation system.
- ▶ Say the commands, numbers, and letters smoothly and with normal volume, emphasis, and speed.
- ▶ Always say commands in the language of the voice activation system.

Requirements

Via the Control Display, set a language that is also supported by the voice activation system so that the spoken commands can be identified.

To set the language, refer to page 48.

Using the voice activation system

Activating the voice activation system

1.  Press button on the steering wheel.
2. Wait for the signal.
3. Say the command.

 This symbol in the instrument cluster indicates that the voice activation system is active. If no other commands are possible, operate the function via iDrive.

Terminating the voice activation system

 Press the button on the steering wheel or ›Cancel‹.

Using a smartphone via voice activation

A smartphone connected to the vehicle can be used via voice activation.

Activate voice command response on the smartphone for this purpose.

1. Press and hold the  button on the steering wheel for approx. 3 seconds. Voice command response is activated on the smartphone.

2. Release the  button.

If activation is successful, a confirmation appears on the Control Display.

If it was not possible to activate voice command response, the list of Bluetooth devices appears on the Control Display.

Possible commands

General information

Most menu items on the Control Display can be voiced as commands.

Commands from other menus can also be spoken.

You may select list entries such as phone list entries via voice activation. Read these list entries out loud exactly as they are shown in the respective list.

Displaying possible commands

The following is displayed in the top area of the Control Display:

- ▶ Some possible commands for the current menu.
- ▶ Some possible commands from other menus.
- ▶ Status of the voice recognition.
- ▶  Encrypted connection is not available.

Help on the voice activation system

- ▶ To have information on the operating principle of the voice activation system read out loud: ›General information on voice control‹.
- ▶ To have help for the current menu read out loud: ›Help‹.

Example: opening the tone settings

The commands of the menu items are spoken just as they are selected via the Controller.

1. Switch on the Entertainment sound output, if needed.
2.  Press button on the steering wheel.
3. ›Media and radio‹
4. ›Tone‹

Settings

Setting the voice dialog

You can set the system to use standard dialog or a short version.

The short version of the voice dialog plays back short messages in abbreviated form.

Via iDrive:

1. "My Vehicle"
2. "iDrive settings"
3. "Language"
4. "Speech mode:"
5. Select the desired setting.

Selecting the input language

For some languages, the input language can be selected.

Via iDrive:

1. "My Vehicle"
2. "iDrive settings"
3. "Language"
4. "Voice control:"
5. Select the desired setting.

Activating voice recognition via the server

The voice recognition feature via the server provides a dictation function and a natural method of entering destinations while improving the quality of voice recognition. To use the functions, data is transmitted to a service provider and locally stored there.

Via iDrive:

1. "My Vehicle"
2. "iDrive settings"
3. "Language"
4. "Server speech recognition"

Speaking during voice output

It is possible to answer during inquiries of the voice activation system. The function can be deactivated if inquiries are often undesirably interrupted, for instance due to background noise or talking.

Via iDrive:

1. "My Vehicle"
2. "iDrive settings"
3. "Language"
4. "Speaking during voice output"

Adjusting the volume

Turn the volume button during the spoken instructions until the desired volume is set.

- ▶ The volume remains constant even if the volume of other audio sources is changed.
- ▶ The volume is stored for the driver profile currently used.

Information on Emergency Requests

Do not use the voice activation system to initiate an Emergency Request. In stressful situations, the voice and vocal pitch can change. This can unnecessarily delay the establishment of a phone connection.

Instead, use the SOS button, refer to page [254](#), close to the interior mirror.

Environmental conditions

- ▶ Keep the doors, windows, and glass sunroof closed to prevent noise interference.
- ▶ Avoid making other noise in the vehicle while speaking.

General settings

Vehicle features and options

This chapter describes all standard, country-specific and optional features offered with the series. It also describes features that are not necessarily available in your vehicle, e. g., due to the selected options or country versions. This also applies to safety-related functions and systems. When using these functions and systems, the applicable laws and regulations must be observed.

Language

Setting the language

Via iDrive:

1. "My Vehicle"
2. "iDrive settings"
3. "Language"
4. "Language:"
5. Select the desired setting.

The setting is stored for the driver profile currently used.

Setting the voice dialog

Voice dialog for the voice activation system, refer to page 46.

Time

Setting the time

Via iDrive:

1. "My Vehicle"
2. "iDrive settings"
3. "Date and time"
4. "Time:"

5. Turn the Controller until the desired hours are displayed.
6. Press the Controller.
7. Turn the Controller until the desired minutes are displayed.
8. Press the Controller.

Setting the time format

Via iDrive:

1. "My Vehicle"
2. "iDrive settings"
3. "Date and time"
4. "Time format:"
5. Select the desired setting.

The setting is stored for the driver profile currently used.

Automatic time setting

Depending on your vehicle's optional features, the time, date and, if needed, the time zone are updated automatically.

Via iDrive:

1. "My Vehicle"
2. "iDrive settings"
3. "Date and time"
4. "Automatic time setting"

The setting is stored for the driver profile currently used.

Date

Setting the date

Via iDrive:

1. "My Vehicle"
2. "iDrive settings"

3. "Date and time"
4. "Date:"
5. Turn the Controller until the desired day is displayed.
6. Press the Controller.
7. Make the settings for the month and year.

Setting the date format

Via iDrive:

1. "My Vehicle"
2. "iDrive settings"
3. "Date and time"
4. "Date format:"
5. Select the desired setting.

The setting is stored for the driver profile currently used.

Setting the units of measurement

You can set the units of measurement for some values, for example, fuel consumption, distances and temperature.

Via iDrive:

1. "My Vehicle"
2. "iDrive settings"
3. "Units"
4. Select the desired menu item.
5. Select the desired setting.

The setting is stored for the driver profile currently used.

Activating/deactivating the display of the current vehicle position

Concept

If vehicle location has been activated, the current vehicle position can be displayed in the BMW Connected app or in the ConnectedDrive customer portal.

Activating/deactivating

Via iDrive:

1. "My Vehicle"
2. "Vehicle settings"
3. "Vehicle tracking"
4. "Vehicle tracking"

Activating/deactivating popup windows

For some functions, popup windows are displayed automatically on the Control Display. Some of these popup windows can be activated or deactivated.

Via iDrive:

1. "My Vehicle"
2. "iDrive settings"
3. "Pop-ups"
4. Select the desired setting.

The setting is stored for the driver profile currently used.

Control Display

Brightness

Via iDrive:

1. "My Vehicle"
2. "iDrive settings"
3. "Displays"
4. "Control display"
5. "Brightness"
6. Turn the Controller until the desired brightness is set.
7. Press the Controller.

The setting is stored for the driver profile currently used.

Depending on the light conditions, the brightness settings may not be clearly visible.

Screensaver

If no settings are made via iDrive, a screensaver will be displayed after an adjustable time.

Via iDrive:

1. "My Vehicle"
2. "iDrive settings"
3. "Displays"
4. "Control display"
5. "Screensaver"
6. Select the desired setting.

The setting is stored for the driver profile currently used.

Selecting the contents of the main menu

For some menu items of the main menu, the displayed contents can be selected.

1.  Press button.
2. "Contents of main menu"

3. Select the desired menu and the desired content.

The setting is stored for the driver profile currently used.

Messages

Concept

The menu centrally displays all messages arriving in the vehicle in list form.

General information

The following messages can be displayed:

- ▶ Traffic messages.
- ▶ Check Control messages.
- ▶ Communication messages, for example e-mails, SMS text messages or reminders.
- ▶ Service requirements messages.

Messages are additionally displayed in the status field.

Retrieving messages

Via iDrive:

1. "Notifications"
2. Select the desired message.

The respective menu is opened, where the message is displayed.

Deleting messages

All messages, except Check Control messages, can be deleted from the list. Check Control messages are displayed as long as they are relevant.

Via iDrive:

1. "Notifications"
2. Select the desired message.
3.  Press button.
4. "Delete this notification" or "Delete all notifications"

Settings

The following settings can be adjusted:

- ▶ Select the applications, from which messages will be permitted.
- ▶ Sort the messages according to date or priority.

Via iDrive:

1. "My Vehicle"
2. "iDrive settings"
3. "Notifications"
4. Select the desired setting.

Data protection

Data transfer

Concept

The vehicle offers different functions, whose use requires a data transfer to BMW or a service provider. The data transfer can be deactivated for some functions.

General information

With data transfer deactivated, the respective function cannot be used.

Only make these settings while stationary.

Activating/deactivating the data transfer

Follow the instructions on the Control Display.

Via iDrive:

1. Switch on standby state.
2. "My Vehicle"
3. "iDrive settings"
4. "Data privacy"
5. Select the desired setting.

Deleting personal data in the vehicle

Concept

Depending on the usage, the vehicle stores personal data, such as stored radio stations. This personal data can be permanently deleted using iDrive.

General information

Depending on the equipment package, the following data can be deleted:

- ▶ Driver profile settings.
- ▶ Stored radio stations.
- ▶ Stored programmable memory buttons.
- ▶ Travel and Onboard Computer information.
- ▶ Music collection.
- ▶ Navigation, for instance stored destinations.
- ▶ Phone book.
- ▶ Online data, for instance Favorites, cookies.
- ▶ Office data, for instance voice notes.
- ▶ Login accounts.

Altogether, the deletion of the data can take up to 15 minutes.

Functional requirement

Data can only be deleted while stationary.

Deleting data

Heed and follow the instructions on the Control Display.

Via iDrive:

1. Switch on standby state.
2. "My Vehicle"
3. "iDrive settings"
4. "Data privacy"
5. "Delete personal data"
6. "Delete personal data"
7. "OK"
8. Exit and lock the vehicle.

After 15 minutes, the deletion process is completed.

If not all of the data was deleted, repeat the deletion.

Canceling deletion

Start the engine to cancel deletion of the data.

Connections

Concept

Various connection types are available for using mobile devices in the vehicle. The connection type to select depends on the mobile device and the desired function.

General information

The following overview shows possible functions and the suitable connection types for them. The scope of functions depends on the mobile device.

Function	Connection type
Making calls via the hands-free system.	Bluetooth.
Using phone functions via iDrive.	
Using the smartphone Office functions.	
Playing music from the smartphone or the audio player.	Bluetooth or USB.
Using compatible apps via iDrive.	Bluetooth or USB.
USB storage device:	USB.
Exporting and importing driver profiles.	
Performing software updates.	
Exporting and importing stored trips.	
Playing music.	

Function	Connection type
Playing videos from the smartphone or the USB storage device.	USB.
Use Apple Carplay apps via iDrive and voice operation.	Bluetooth and WiFi.

The following connection types require one-time pairing with the vehicle:

- ▶ Bluetooth.
- ▶ Internet hotspot.
- ▶ Apple CarPlay.

Paired devices are automatically recognized later on and connected to the vehicle.

Safety information

WARNING

Operating the integrated information systems and communication devices while driving can distract from traffic. It is possible to lose control of the vehicle. There is a risk of an accident. Only use the systems or devices when the traffic situation allows. As warranted, stop and use the systems and devices while the vehicle is stationary.

Compatible devices

General information

Information on mobile devices compatible with the vehicle can be found at www.bmwusa.com/bluetooth.

Malfunctions may occur with devices not listed or deviating software versions.

Displaying the vehicle identification number and software part number

When looking for compatible devices, you may have to state the vehicle identification number

and the software part number. These numbers can be displayed in the vehicle.

Via iDrive:

1. "My Vehicle"
2. "iDrive settings"
3. "Mobile devices"
4. "Settings"
5. "Bluetooth® info"
6. "System information"

A software update, refer to page 57, can be performed, if needed.

Bluetooth connection

Functional requirements

- ▶ Compatible device, refer to page 52, with Bluetooth interface.
- ▶ The remote control is in the vehicle.
- ▶ The device is ready for operation.
- ▶ Bluetooth is activated on the device and in the vehicle, refer to page 53.
- ▶ Bluetooth presets, such as visibility, may be required on the device; refer to the owner's manual of the device.

Switching on Bluetooth





Via iDrive:

1. "My Vehicle"
2. "iDrive settings"
3. "Mobile devices"
4. "Settings"
5. "Bluetooth®"

Pairing the mobile device with the vehicle

Via iDrive:

1. "My Vehicle"
2. "iDrive settings"
3. "Mobile devices"

4. "Connect new device"
5. Select the functions for which the device will be used:
 - ▶  "Telephone"
 - ▶  "Bluetooth® audio"
 - ▶  "Apps"
 - ▶  "Apple CarPlay"

The Bluetooth name of the vehicle is displayed on the Control Display.

6. Search for Bluetooth devices in the vicinity of the mobile device.

The Bluetooth name of the vehicle appears on the mobile device display.

Select the Bluetooth name of the vehicle.

7. Depending on the mobile device, a control number is displayed or the control number must be entered.

- ▶ Compare the control number displayed on the Control Display with the control number on the display of the device.

Confirm the control number on the device and on the Control Display.

- ▶ Enter and confirm the same control number on the device and via iDrive.

The device is connected and displayed in the device list, refer to page 56.

If connection was not successful: Frequently Asked Questions, refer to page 53.

Frequently asked questions

All requirements are met and all required steps were completed in the specified order. Despite that, the mobile device does not function as expected.

In this case, the following explanations can help: Why could the mobile phone not be paired or connected?

- ▶ There are too many Bluetooth devices connected to the mobile phone or vehicle.

In the vehicle, delete Bluetooth connections with other devices.

Delete all known Bluetooth connections from the device list on the mobile phone and start a new device search.

- ▷ The mobile phone is in power-save mode or has only a limited remaining battery life.

Charge mobile phone.

Why does the mobile phone no longer react?

- ▷ The applications on the mobile phone do not function anymore.

Switch the mobile phone off and on again.

- ▷ Too high or too low ambient temperatures for mobile phone operation.

Do not subject the mobile phone to extreme ambient temperatures.

Why can phone functions not be used via iDrive?

- ▷ The mobile phone may not be properly configured, for instance as Bluetooth audio device.

Connect the mobile phone with the telephone or additional phone function.

Why are no or not all phone book entries displayed or why are they incomplete?

- ▷ Transmission of the phone book entries is not yet complete.
- ▷ It is possible that only the phone book entries of the mobile phone or the SIM card are transmitted.
- ▷ It may not be possible to display phone book entries with special characters.
- ▷ It may not be possible to transmit contacts from social networks.
- ▷ The number of phone book entries to be stored is too high.
- ▷ Data volume of the contact too large, for instance due to stored information such as notes.
Reduce the data volume of the contact.
- ▷ A mobile phone can only be connected as audio source or as telephone.

Configure the mobile phone and connect it with the telephone or additional phone function.

How can the phone connection quality be improved?

- ▷ The strength of the Bluetooth signal on the mobile phone can be adjusted, depending on the mobile phone.

If all points in this list have been checked and the required function is still not available, contact the hotline, a dealer's service center or another qualified service center or repair shop.

USB connection

General information

Mobile devices with a USB port are connected to the USB interface.

- ▷ Mobile phones.
- ▷ Audio devices with USB port, for instance MP3 player.
- ▷ USB storage devices.
Common file systems are supported. FAT32 and exFAT are the recommended formats.

The following applications are possible:

- ▷ Exporting and importing driver profiles, refer to page 79.
- ▷ Playing music files via USB audio.
- ▷ Playing videos via USB video.
- ▷ Loading of software updates, refer to page 57.

Follow the following when connecting:

- ▷ Do not use force when plugging the connector into the USB interface.
- ▷ Use a flexible adapter cable.
- ▷ Protect the USB storage device against mechanical damage.
- ▷ Due to the large number of USB media available on the market, it cannot be guaranteed that every device is operable on the vehicle.

- ▶ Do not expose USB media to extreme environmental conditions, such as very high temperatures; refer to the owner's manual of the device.
- ▶ Due to the many different compression techniques, proper playback of the media stored on the USB storage device cannot be guaranteed in all cases.
- ▶ A connected USB storage device will be supplied with charging current via the USB interface if the device supports this.
- ▶ To ensure proper transmission of the stored data, do not charge a USB storage device via the onboard socket, when it is connected to the USB interface.
- ▶ Depending on how the USB storage device is being used, settings may be required on the USB storage device, refer to the owner's manual of the device.

Not compatible USB media:

- ▶ USB hard drives.
- ▶ USB hubs.
- ▶ USB memory card readers with multiple inserts.
- ▶ HFS-formatted USB media.
- ▶ Devices such as fans or lamps.

Functional requirement

Compatible device, refer to page [52](#), with USB interface.

Connecting the device

Connect the USB storage device using a suitable adapter cable to a USB interface, refer to page [187](#).

The USB storage device is displayed in the device list, refer to page [56](#).

Apple CarPlay preparation

Concept

CarPlay allows certain functions of a compatible Apple iPhone to be used via Siri voice operation and iDrive.

Functional requirements

- ▶ Compatible iPhone, refer to page [52](#).
iPhone 5 or later with iOS 7.1 or later.
- ▶ Corresponding mobile wireless contract.
- ▶ Bluetooth, WiFi, and Siri voice operation are switched on on the iPhone.

Switching on Bluetooth and CarPlay

Via iDrive:

1. "My Vehicle"
2. "iDrive settings"
3. "Mobile devices"
4. "Settings"
5. Select the following settings:
 - ▶ "Bluetooth®"
 - ▶ "Apple CarPlay"

Pairing iPhone with CarPlay

Pair iPhone via Bluetooth with the vehicle, refer to page [53](#).

Select CarPlay as the function:

- ▶ "Apple CarPlay"

The iPhone is connected to the vehicle and displayed in the device list, refer to page [56](#).

Operation

For more information, see the Integrated Owner's Manual, Online Owner's Manual, BMW i Driver's Guide app or the Owner's Manual for Navigation, Entertainment, and Communication.

Frequently asked questions

All requirements are met and all required steps were completed in the specified order. Despite that, the mobile device does not function as expected.

In this case, the following explanations can help: The iPhone has already been paired with Apple CarPlay. When a new connection is established, CarPlay can no longer be selected.

- ▶ Delete the iPhone concerned from the device list.
- ▶ On the iPhone, delete the vehicle concerned from the list of stored vehicles under Bluetooth and under WiFi.
- ▶ Pair the iPhone as a new device.

If the steps listed have been carried out and the required function is still not available: contact the hotline, a dealer's service center or another qualified service center or repair shop.

Managing mobile devices

General information

- ▶ After one-time pairing, the devices are automatically recognized and reconnected when standby state is switched on.
- ▶ The data stored on the SIM card or in the mobile phone are transferred to the vehicle after recognition.
- ▶ For some devices, certain settings may be necessary, for instance authorization, see owner's manual of the device.



Displaying the device list

All devices paired or connected with the vehicle are displayed in the device list.

Via iDrive:

1. "My Vehicle"
2. "iDrive settings"
3. "Mobile devices"

A symbol indicates, for which function a device is used.

Symbol	Function
	"Telephone"
	"Apps"
	"Apple CarPlay"

Configuring the device

Functions can be activated or deactivated for paired and connected devices.

Via iDrive:

1. "My Vehicle"
2. "iDrive settings"
3. "Mobile devices"
4. Select the desired device.
5. Select the desired setting.

If a function is assigned to a device, the function will be deactivated where appropriate for a device that is already connected and the device will be disconnected.

Disconnecting the device

The connection of the device to the vehicle is disconnected.

The device remains paired and can be connected again, refer to page 56.

Via iDrive:

1. "My Vehicle"
2. "iDrive settings"
3. "Mobile devices"
4. Select device.
5. "Disconnect device"

Connecting the device

A disconnected device can be reconnected.

Via iDrive:

1. "My Vehicle"
2. "iDrive settings"
3. "Mobile devices"
4. Select device.
5. "Connect device"

The functions that were assigned to the device before disconnecting are assigned to the device when it is reconnected. If the device is already connected, these functions are deactivated.

Deleting the device

Via iDrive:

1. "My Vehicle"
2. "iDrive settings"
3. "Mobile devices"
4. Select device.
5. "Delete device"

The device is disconnected and removed from the device list.

Software update

General information

The vehicle supports a large number of mobile devices, for instance mobile phones and MP3 players. Software updates are available for many of the supported devices. The vehicle is maintained up-to-date via regular vehicle software updates.

Updates and related current information is available at www.bmw.com/update.

Displaying the installed software version

The software version installed in the vehicle is displayed.

Via iDrive:

1. "My Vehicle"
2. "iDrive settings"

3. "Software update"
4. "Show current version"

If an update has been carried out before, select the desired version to display additional information.

Updating software via USB

The software may only be updated when the vehicle is stationary.

Via iDrive:

1. Store the file for the software update in the main directory of a USB flash drive.
2. Connect the USB storage device to a USB interface, refer to page [187](#).
3. "My Vehicle"
4. "iDrive settings"
5. "Software update"
6. "Update software"
7. "USB"
8. "Install software"
9. "OK"
10. Wait for the update to complete.
11. Confirm system restart.

Restoring the software version

The software version before the last software update and the version before the first software update can be restored.

The software may only be restored when the vehicle is stationary.

Via iDrive:

1. "My Vehicle"
2. "iDrive settings"
3. "Software update"
4. "Restore software"
5. ▶ "Previous version"
 - The previous software version is restored.
- ▶ "Default software settings"



The first software version is restored.

6. "Remove software"
7. "OK"
8. Wait for restore.
9. Confirm system restart.

Owner's Manual media

Vehicle features and options

This chapter describes all standard, country-specific and optional features offered with the series. It also describes features that are not necessarily available in your vehicle, e. g., due to the selected options or country versions. This also applies to safety-related functions and systems. When using these functions and systems, the applicable laws and regulations must be observed.

General information

You can use various media formats to call up the content in the Owner's Manual. The following Owner's Manual media formats are available:

- ▶ Printed Owner's Manual, refer to page [59](#).
- ▶ Integrated Owner's Manual in the vehicle, refer to page [59](#).
- ▶ BMW i Driver's Guide app, refer to page [60](#).
- ▶ Online Owner's Manual, refer to page [61](#).

There are different features, refer to page [62](#), in each of the different media formats.

Printed Owner's Manual

Concept

The printed Owner's Manual describes all standard, country-specific, and optional features offered with the series.

General information

The Owner's Manual for Navigation, Entertainment, and Communication can be obtained as printed book from the service center.

Integrated Owner's Manual in the vehicle

Concept

The Integrated Owner's Manual specifically describes features and functions found in the vehicle. The Integrated Owner's Manual can be displayed on the Control Display.

Selecting the Owner's Manual

1.  Press button.
2. "My Vehicle"
3. "Owner's Manual"
4. Select the required method of accessing the contents.

Scrolling through the owner's manual

Turn the Controller, until the next or previous contents are displayed.

Context help

General information

The section of the Owner's Manual relating to the function that is currently selected can be displayed directly.

Opening via iDrive

Change directly to the Options menu from the function on the Control Display:

1.  Press button.
2. "Owner's Manual"



Opening when a Check Control message is displayed

Directly from the Check Control message on the Control Display:

 "Owner's Manual"

Changing between a function and the Owner's Manual

To switch from a function, for instance radio, to the Owner's Manual on the Control Display and to alternate between the two displays:

1.  Press button.
2. "Owner's Manual"
3. Select the desired page in the Owner's Manual.
4.  Press button again to return to last displayed function.
5.  Press button to return to the page of the Owner's Manual displayed last.

To alternate continuously between the last displayed function and the last displayed page of the Owner's Manual, repeat steps 4 & 5. Opens a new display every time.



Programmable memory buttons

General information



The jumps into the Owner's Manual can be stored on the programmable memory buttons, refer to page 43, and called up directly.

Storing

1. Select the desired entry point via iDrive:
 - ▶ "Quick reference"
 - ▶ "Search by pictures"
 - ▶ "Keyword search"
 - ▶ "Animations"

2. ... Press desired programmable memory button and hold for more than 2 seconds.

Executing

1. ... Press the corresponding button. The owner's manual is directly displayed at the selected entry point.

BMW i Driver's Guide app

Concept

The BMW i Driver's Guide app specifically describes features and functions found in the vehicle.

The app can be displayed on smartphones and tablets.

General information

The Owner's Manual is available in many countries as an app. Additional information on the Internet:

www.bmw.com/bmw_i_drivers_guide

Entering the vehicle identification number filters the contents.

Vehicles

It is possible to store Owner's Manuals for various vehicles in the app.

It is also possible to test the app using a demonstration vehicle.

Operating systems and language

The app is available for the iOS and Android operating systems.

The Owner's Manual is downloaded in the language of the device.

Online Owner's Manual

Concept

The Online Owner's Manual specifically describes features and functions found in the vehicle.

The Online Owner's Manual can be displayed in any of today's browsers.

General information

The Online Owner's Manual is available in many countries. An account on the customer portal may be required.

Entering the vehicle identification number filters the contents.

Vehicles

It is possible to store several individual Owner's Manuals for various vehicles.

Language

The language is based on whichever language is set in the operating system.

Printing

You can use the print function for automatically formatting and printing out individual chapters.

Media components

General information

The following components are not available to the same extent in all media formats.

Additional information on availability, refer to page [62](#).

Quick Reference Guide

The Quick Reference Guide provides information on how to operate the vehicle, how to use basic vehicle functions and what to do in case of a breakdown.

Search by illustrations

Based on illustrations, image search provides information and descriptions. This is helpful when the terminology for a feature is not at hand.

Frequently asked questions

This chapter provides answers to frequently asked questions about your vehicle and helpful links to additional information.

Quick links

The chapter on quick links explains the most important information and operating instructions on the basis of various situations.

Videos

The videos explain the main functions of the systems.

Smart Scan

You can use Smart Scan to scan various symbols in the vehicle. After a brief explanation of the symbol in question appears, it is then possible to display the chapter directly.

Smart Scan is only available for the iOS operating system.

Keyword search

You can use keywords to search for information and descriptions in the media.

Key features

	Printed	Integrated	APP	Online
All equipment included.	X	—	—	—
Equipment included in vehicle.	—	X	X	X
Quick Reference Guide.	X	X	X	X
Search by illustrations.	—	X	X	X
Frequently asked questions.	—	—	X	X
Quick links.	—	—	X	X
Videos.	—	X	X	X
Smart Scan.	—	—	X	—
Keyword search.	X	X	X	X

X: included.
 —: not included.

BMW eDRIVE

Vehicle features and options

This chapter describes all standard, country-specific and optional features offered with the series. It also describes features that are not necessarily available in your vehicle, e. g., due to the selected options or country versions. This also applies to safety-related functions and systems. When using these functions and systems, the applicable laws and regulations must be observed.

BMW eDRIVE

Special features of the BMW i

High-voltage system

This BMW i is an electric vehicle. The vehicle features a high-voltage system that consists of an electric motor and a high-voltage battery among other things.

Optionally, the vehicle has a combustion engine that generates electrical energy via a generator and thereby increases the range. This combustion engine is called the Range Extender.

Carbon body

The vehicle consists of the functional units:

- ▶ Drive module of aluminum.
- ▶ Life module of carbon fiber reinforced plastic, CFRP.

Overview

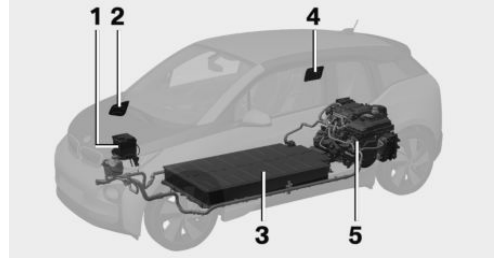

- 1 Vehicle battery
- 2 Fuel filler flap
- 3 High-voltage battery
- 4 Charging socket
- 5 Drive unit

Concept

The vehicle can be operated emissions free using its electrical drive system.

The special high-voltage battery supplies the electric motor as well as the comfort features with power.

The high-voltage battery is charged via a charging cable, for instance when parked or while driving by energy recovery.

The vehicle can be charged very rapidly at special charging stations. Charging is also possible at household power sockets.

On the go, the energy recovery ensures that only little energy is lost when braking.

When the vehicle decelerates, the electric motor acts as a generator and converts the kinetic energy released into electric current.

As a result the high-voltage battery is partially recharged in order to reach maximum range.

An optional Range Extender can supply the drive system with power and thus increase the range of the vehicle.

Functions

Electric driving: eDRIVE

The vehicle is powered exclusively by the electric motor. The accelerator pedal can be used not just for acceleration, but also for deceleration. When the vehicle decelerates, the electric motor acts as a generator and charges the high-voltage battery. With a sensible driving style, this function can be used for especially efficient energy recovery and comfortable driving, using just the accelerator pedal.

Acoustic pedestrian protection

Depending on the country-specific version, the system generates a continuous driving noise during electric driving at low speeds.

Coasting

An especially efficient operating point is so-called coasting. In this case, the vehicle is decelerated only by driving resistance and no energy flows between high-voltage battery and electric motor. In order to coast, depress the accelerator pedal far enough that the mark in the instrument cluster, refer to page 114, is exactly in the center.

Energy recovery: CHARGE

The high-voltage battery is charged while driving through energy recovery.

The electric motor acts as a generator and converts the kinetic energy of the vehicle into electrical energy.

Charging can take place in various situations while the vehicle is in motion:

- ▶ As soon as the accelerator pedal is only slightly depressed.
- ▶ During vehicle braking.

The mark in the instrument cluster is located within the CHARGE range.

Sensible driving and early speed reduction are important to make full use of the energy recovery feature.

Display

The eDRIVE displays, refer to page 115, provide information about the current state of the drive and visualize the system's use in a diagram.

Maximize energy-saving driving and range

Energy-saving driving is the basic prerequisite for as large a range as possible. eDRIVE provides various functions that assist with an energy-saving driving style and help to monitor the range, and if needed, to increase it. The following descriptions provide an overview of the available functions and the personal measures.

Before driving

eDRIVE allows using the air conditioner even before driving off. The stationary climate control, refer to page 178, provides more range than using full air conditioning while driving.

Parked vehicle ventilation during the charging process can provide maximum range when driving off.

Trip planning and special functions of the navigation system

Several special functions of the navigation system support trip planning taking into account the electric range:

- ▶ Range assistant, refer to Integrated Owner's Manual, checks whether an entered navigation destination can be reached. If the range is not sufficient, various recommendations to help increase the range are displayed automatically, for instance an alternative ECO PRO route is displayed.
- ▶ Intermodal routing or intermodal information, refer to Integrated Owner's Manual, as route

criterion support trip planning using public transportation.

- ▶ Range map indicates the action range on the navigation map, refer to Integrated Owner's Manual.
- ▶ Charging assistant under Points of Interest in navigation, helps to find and possibly include a public charging station in the desired route, refer to Integrated Owner's Manual.

During driving

- ▶ General driving tips, refer to page 204, for increasing the range.
- ▶ Use the eDRIVE system efficiently, refer to page 198, for an optimized driving style.
- ▶ ECO PRO driving style analysis, refer to page 207, for driving style analysis.
- ▶ ECO PRO and ECO PRO+, refer to page 205, driving mode for increasing the range.
- ▶ Display of the fuel consumption history, refer to page 117.
- ▶ Display of secondary functions and the potential range, refer to page 117.

After the trip

- ▶ Charge vehicle, refer to page 210, and plan next trip.
- ▶ Prepare for long downtimes, refer to page 262.

BMW i Remote app

A special BMW i Remote App allows you to control and display certain vehicle functions using a smartphone.

Safety of the high-voltage system

Follow the information on safety, refer to page 66.

Long-term vehicle storage

Observe the information on vehicle storage and for longer idle periods, refer to page 262.

Safety of the high-voltage system

Safety of the high-voltage system

Working on the vehicle

DANGER

Improperly executed work, in particular maintenance and repair on the high-voltage system and the carbon body as well as accessories retrofits, can lead to electric shock. There is a risk of injury, fire and danger to life. The manufacturer of your vehicle recommends that the work on the vehicle, in particular maintenance and repair, be performed only by an authorized BMW i dealer's service center or another qualified service center or repair shop.

Contact with water

The high-voltage system is typically safe even in the following example situations:

- ▶ Water in the floor area, for instance after a rainstorm when the roof was kept open.
- ▶ Vehicle is in water but only up to the allowed height.
- ▶ Fluid escapes in the cargo area.

Automatic deactivation

If an accident occurs, the high-voltage system is switched off automatically to prevent risk of danger to occupants and other traffic.

Read the information on What to do after an accident, refer to page [257](#).





↓ CONTROLS

Opening and closing	70
Seats, mirrors, and steering wheel	88
Transporting children safely	96
Driving	100
Displays	114
Lights	129
Safety	133
Driving stability control systems	149
Driving comfort	153
Climate control	172
Interior equipment	181
Storage compartments	191

Opening and closing

Vehicle features and options

This chapter describes all standard, country-specific and optional features offered with the series. It also describes features that are not necessarily available in your vehicle, e. g., due to the selected options or country versions. This also applies to safety-related functions and systems. When using these functions and systems, the applicable laws and regulations must be observed.

Remote control

General information

The vehicle is supplied with two remote controls with integrated key.

Each remote control contains a replaceable battery. Replacing the battery, refer to page 72.

You may set the button functions, depending on the vehicle equipment and country version. Settings, refer to page 82.

The vehicle stores personal settings for every remote control. Driver profile, refer to page 79.

The remote controls hold information about required maintenance. Service data in the remote control, refer to page 249.

Safety information

WARNING

People or animals in the vehicle can lock the doors from the inside and lock themselves in. In this case, the vehicle cannot be opened from the outside. There is a risk of injury. Take the remote control with you so that the vehicle can be opened from the outside.

WARNING

Unlocking from the inside is only possible with special knowledge.

Persons who spend a lengthy time in the vehicle while being exposed to extreme temperatures are at risk of injury or death. Do not lock the vehicle from the outside when there are people in it.

WARNING

Unattended children or animals can cause the vehicle to move and endanger themselves and traffic, for instance due to the following actions:

- ▷ Pressing the Start/Stop button.
- ▷ Releasing the parking brake.
- ▷ Opening and closing the doors or windows.
- ▷ Engaging selector lever position N.
- ▷ Using vehicle equipment.

There is a risk of accidents or injuries. Do not leave children or animals unattended in the vehicle. Take the remote control with you when exiting and lock the vehicle.

Overview

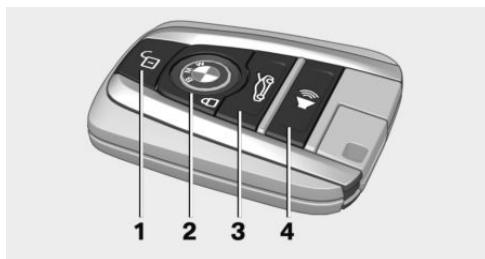

- 1 Unlocking
- 2 Locking

- 3 Unlocking the tailgate
- 4 Panic mode

Unlocking



Press button on the remote control.

Depending on the settings, refer to page 82, the following access points are unlocked:

- ▷ Driver's door.
Press the button of the remote control again to unlock the other vehicle access points.

- ▷ All doors and tailgate.

In addition, the following functions are executed:

- ▷ Unlocking is confirmed by the turn signals and the horn. This function must be activated in the settings, refer to page 82.
- ▷ The settings stored in the driver profile, refer to page 79, are applied.
- ▷ The interior lights, refer to page 131, are switched on, unless they were manually switched off.
- ▷ Depending on the settings, the welcome light and headlight courtesy delay feature, refer to page 130, are switched on.
- ▷ Exterior mirrors folded through convenient closing are folded open.
- ▷ The alarm system, refer to page 82, is switched off.

The light functions may depend on the ambient brightness.

Convenient opening



Press and hold this button on the remote control after unlocking.

Pressing and holding the button on the remote control opens the windows and the glass sunroof.

Locking

1. Close the driver's door.
2.  Press button on the remote control.

The following functions are executed:

- ▷ All doors and the tailgate are locked.
- ▷ Locking is confirmed by the turn signals and the horn. This function must be activated in the settings, refer to page 82.
- ▷ The alarm system, refer to page 82, is switched on.

If the drive-ready state is still switched on when you lock the vehicle, the vehicle horn honks twice. In this case, the drive-ready state must be switched off by means of the Start/Stop button.

With Comfort Access: convenient closing

Safety information

WARNING

With convenient closing, body parts can be jammed. There is a risk of injury. Make sure that the area of movement of the doors is clear during convenient closing.

Closing



Press and hold this button on the remote control in the area close to the vehicle.

The windows and the glass sunroof are closed, as long as the button on the remote control is pressed.

The exterior mirrors are folded in.

The exterior mirrors are not folded in when the hazard warning flashers are switched on.



Switching on interior lights and courtesy light



Press button on the remote control with the vehicle locked.

This function is not available, if the interior lights were switched off manually.

The light functions may depend on the ambient brightness.

After locking, wait 10 seconds before pressing the button again.

Tailgate

General information

To avoid locking it in the vehicle, do not place the remote control in the cargo area.

Depending on the vehicle equipment and country version, it is possible to specify whether the doors are also unlocked when unlocking with the remote control. Adjusting the settings, refer to page 82.

Safety information

WARNING

Body parts can be jammed when operating the tailgate. There is a risk of injury. Make sure that the area of movement of the tailgate is clear during opening and closing.

NOTE

The tailgate swings back and up when it opens. There is a risk of damage to property. Make sure that the area of movement of the tailgate is clear during opening and closing.

NOTE

Sharp-edged or pointed objects can hit the rear window and heat conductors while driving. There is a risk of damage to property. Cover the edges and ensure that pointed objects do not hit the rear window.

Opening



Press button on the remote control for approx. 1 second.

The tailgate is unlocked and can be swung upward.

Panic mode

You can trigger the alarm system if you find yourself in a dangerous situation.



- ▶ Press button on the remote control and hold for at least 3 seconds.
- ▶ Briefly press the button on the remote control three times in succession.

To switch off the alarm: press any button.

Replacing the battery

1. Remove the integrated key from the remote control, refer to page 74.
2. Place the integrated key underneath the battery compartment cover, arrow 1, and lift the cover with a lever movement of the integrated key, arrow 2.

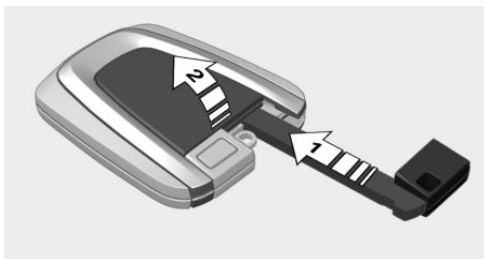



3. Push battery in the direction of the arrow using a pointed object and lift it out.

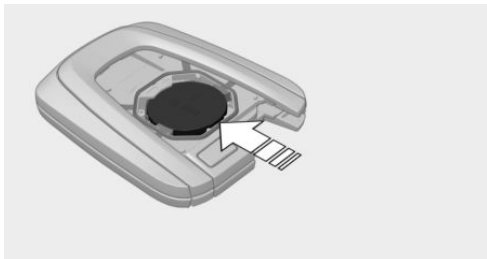

4. Insert a type CR 2032 battery with the positive side facing up.
5. Press the cover closed.
6. Push the integrated key into the remote control until it engages.



Have old batteries disposed of by a dealer's service center or another qualified service center or repair shop or take them to a collection point.

Additional remote controls

Additional remote controls are available from a dealer's service center or another qualified service center or repair shop.

Loss of the remote controls

A lost remote control can be blocked and replaced by a dealer's service center or another qualified service center or repair shop.

Malfunction

General information

A Check Control message is displayed.

Remote control detection by the vehicle may malfunction under the following circumstances:

- ▶ The battery of the remote control is discharged. Replacing the battery, refer to page 72.

- ▶ Interference of the radio connection from transmission towers or other equipment with high transmitting power.
- ▶ Shielding of the remote control due to metal objects.
Do not transport the remote control together with metal objects.
- ▶ Interference of the radio connection from mobile phones or other electronic devices in direct proximity to the remote control.
Do not transport the remote control together with electronic devices.
- ▶ Interference of radio transmission by a charging process of mobile devices, for instance charging of a mobile phone.

In the case of interference, the vehicle can be unlocked and locked from the outside with the integrated key, refer to page 74.

Switching the drive-ready state on via emergency detection of the remote control

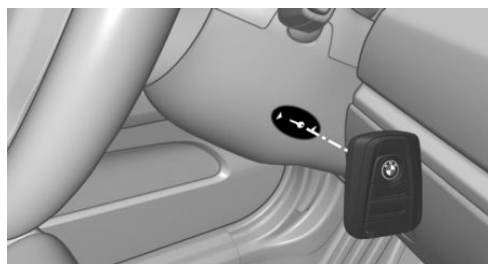

It is not possible to switch on the drive-ready state if the remote control has not been detected.

Proceed as follows in this case:

1. Hold the remote control with its back against the marked area on the steering column. Pay attention to the display in the instrument cluster.
2. If the remote control is detected:
Switch on drive-ready state within 10 seconds.



If the remote control is not detected, slightly change the position of the remote control and repeat the procedure.

Integrated key

General information

The driver's door can be locked and unlocked without remote control using the integrated key.

Safety information

WARNING

Unlocking from the inside is only possible with special knowledge.

Persons who spend a lengthy time in the vehicle while being exposed to extreme temperatures are at risk of injury or death. Do not lock the vehicle from the outside when there are people in it.

NOTE

The door lock is permanently joined with the door. The door handle can be moved. When pulling the door handle with the integrated key inserted, paint or the integrated key can be damaged. There is a risk of damage to property. Remove the integrated key before pulling the outside door handle.

Removing

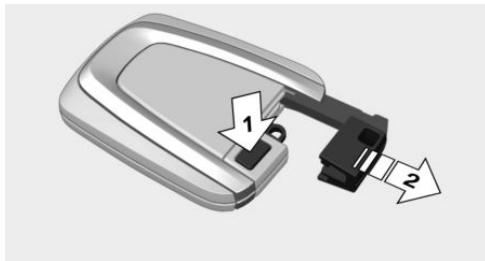

Press the button, arrow 1, and pull out the integrated key, arrow 2.

Locking/unlocking via the door lock

1. Remove lid on the door lock.

To do this, slide the integrated key into the opening from below and unlock the lid.

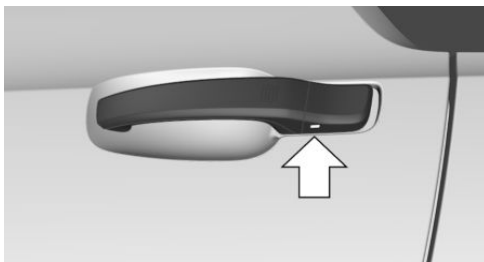

2. Unlock or lock the door lock using the integrated key.



The other doors must be unlocked or locked from the inside.

Alarm system

The alarm system is not switched on if the vehicle is locked with the integrated key.

The alarm system is triggered when the door is opened, if the vehicle has been unlocked via the door lock.

In order to stop the alarm, unlock the vehicle with the remote control or establish the radio-ready state, if needed, through emergency detection of the remote control, refer to page 73.

Buttons for the central locking system

General information

In the event of a severe accident, the vehicle is automatically unlocked. The hazard warning system and interior lights come on.

Overview



Buttons for the central locking system.

Locking



Press the button with the doors closed.

The vehicle is not secured against theft when locking.

Unlocking



Press button.

The vehicle locks automatically after you drive off.

Opening

- ▶  Press button to unlock the doors together, and then pull the door handle above the armrest.
- ▶ Pull the door opener on the door to be opened. The other door remain locked.

Rear doors

General information

Before exiting the vehicle, make sure that the front safety belt is completely wound up.

Overview

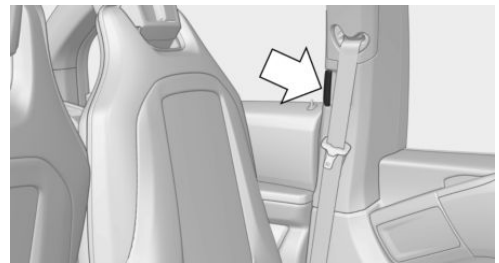

The door openers are located on the inside, next to the front safety belts.

Opening

1. Open the corresponding front door.
2. Pull door opener backward.

To better reach the front door's handle fold the front seat's backrests, refer to page 89, down.

Closing

When closing, make sure that the corresponding front door is far enough open.



Comfort Access

Concept

The vehicle can be accessed without activating the remote control.

All you need to do is to have the remote control with you, such as in your pants pocket.

The vehicle automatically detects the remote control when it is in close proximity or in the car's interior.

General information

Comfort Access supports the following functions:

- ▷ Unlocking and locking the vehicle.
- ▷ Convenient closing.
- ▷ Open the tailgate.

Functional requirements

- ▷ To lock the vehicle, the remote control must be located outside of the vehicle near the doors.
- ▷ The next unlocking and locking cycle is not possible until after approx. 2 seconds.

Unlocking



Grasp the door handle on the driver's or front passenger door completely.

This corresponds with pressing the button  on the remote control.

Locking

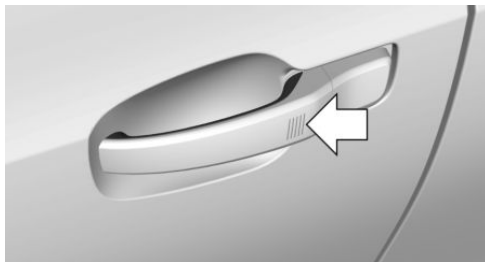

Touch the surface on the door handle of the driver's or front passenger door with your finger for approx. 1 second without grasping the door handle.

This corresponds with pressing the button  on the remote control.

Convenient closing

Safety information

WARNING

With convenient closing, body parts can be jammed. There is a risk of injury. Make sure that the area of movement of the doors is clear during convenient closing.

Closing

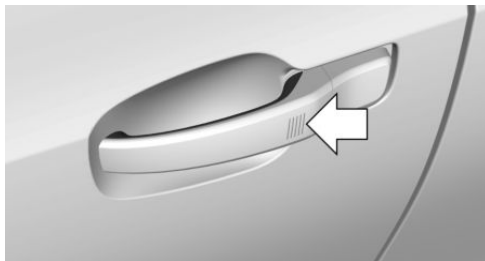

Touch the surface on the door handle of the driver's or front passenger door, arrow, with your finger and hold it there without grasping the door handle.



This corresponds with pressing and holding the button  on the remote control.

In addition to locking, the windows and the glass sunroof close. The exterior mirrors fold in, depending on the model.

Opening the tailgate

General information

To avoid locking it in the vehicle, do not place the remote control in the cargo area.

If the tailgate is opened via Comfort Access, locked doors are not unlocked.

Safety information

WARNING

Body parts can be jammed when operating the tailgate. There is a risk of injury. Make sure that the area of movement of the tailgate is clear during opening and closing.

NOTE

The tailgate swings back and up when it opens. There is a risk of damage to property. Make sure that the area of movement of the tailgate is clear during opening and closing.

NOTE

Sharp-edged or pointed objects can hit the rear window and heat conductors while driving. There is a risk of damage to property. Cover the edges and ensure that pointed objects do not hit the rear window.

Opening



Press button next on tailgate.

This corresponds with pressing the button  on the remote control.

The tailgate is unlocked and can be swung upward.

Malfunction

Remote control detection by the vehicle may malfunction under the following circumstances:

- ▶ The battery of the remote control is discharged. Replace the battery, refer to page 72.
- ▶ Interference of the radio connection from transmission towers or other equipment with high transmitting power.
- ▶ Shielding of the remote control due to metal objects.
Do not transport the remote control together with metal objects.
- ▶ Interference of the radio connection from mobile phones or other electronic devices in direct proximity to the remote control.
Do not transport the remote control together with electronic devices.

Wet or snowy conditions may disrupt the locking request recognition function on the door handles.

In the case of a malfunction, unlock and lock the vehicle using the buttons of the remote control or using the integrated key, refer to page 74.



Hood

Safety information

WARNING

Body parts can be jammed when opening and closing the hood. There is a risk of injury. Make sure that the area of movement of hood is clear during opening and closing.

NOTE

Folded-away wipers can be jammed when the hood is opened. There is a risk of damage to property. Make sure that the wipers with the wiper blades mounted are folded down onto the windshield before opening the hood.

Unlocking from the inside



With the vehicle stationary, press the button in the driver's floor area.

The hood is unlocked and slightly raised.

Opening

1. Press the release handle and open the hood.

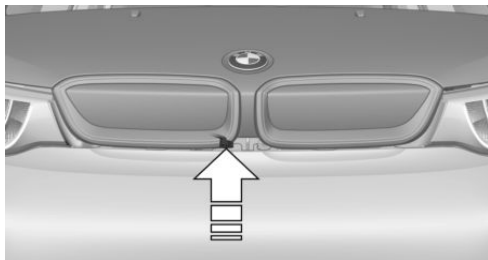

Malfunction

In case of an electrical malfunction, the hood can be unlocked manually.

1. Remove cover underneath the unlock buttons.

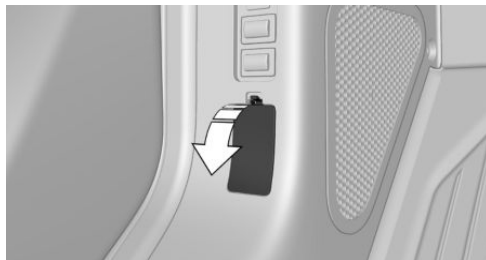

2. Remove wire cable and pull it back.
The hood is unlocked and slightly raised.

Tailgate

General information

To avoid locking it in the vehicle, do not place the remote control in the cargo area.

Depending on the vehicle equipment and country version, it is possible to specify whether the doors are also unlocked when unlocking with the remote control. Adjusting the settings, refer to page 82.

Safety information

WARNING

Body parts can be jammed when operating the tailgate. There is a risk of injury. Make sure that the area of movement of the tailgate is clear during opening and closing.

NOTE

The tailgate swings back and up when it opens. There is a risk of damage to property. Make sure that the area of movement of the tailgate is clear during opening and closing.

NOTE

Sharp-edged or pointed objects can hit the rear window and heat conductors while driving. There is a risk of damage to property. Cover the edges and ensure that pointed objects do not hit the rear window.

Opening and closing

Opening from the outside



- ▶ Without Comfort Access: unlock vehicle.
With Comfort Access: unlock the vehicle or have the remote control with you.
Press button next on tailgate.
- ▶  Press button on the remote control for approx. 1 second.

Depending on the setting, the doors may also be unlocked. Unlocking with the remote control, refer to page 72.

The tailgate is opened slightly and can be swung upward.

Opening from the inside



With the vehicle stationary, press the button in the driver's floor area twice in quick succession.

If the vehicle is locked, selector lever position P must be engaged first.

The tailgate is opened slightly and can be swung upward.

Closing



Grasp the recess grip and pull tailgate down.

Driver profile

Concept

In the driver profiles, individual settings for several drivers can be stored and called up again when required.

General information

There are three driver profiles with which personal vehicle settings can be stored. Every remote control has one of these driver profiles assigned.

If the vehicle is unlocked using a remote control, the assigned personal driver profile will be activated. All settings stored in the driver profile are automatically applied.

If several drivers use their own remote control, the vehicle will adjust the personal settings during unlocking. These settings are also restored, if



the vehicle has been used in the meantime by a person with a different remote control.

Changes to the settings are automatically stored in the driver profile currently activated.

If another driver profile is selected via iDrive, the settings stored in it will be applied automatically. The new driver profile is assigned to the remote control currently used.

There is an additional guest profile available that is not assigned to any remote control. It can be used to apply settings in the vehicle without changing the personal driver profiles.

Functional requirements

For the system to be able to identify the driver profile associated to a particular driver, the detected remote control must be clearly allocated to the driver.

This is the case when:

- ▶ The driver is only carrying his or her own remote control.
- ▶ The driver unlocks the vehicle.
- ▶ The driver gets into the vehicle through the driver's door.

Settings

The settings for the following systems and functions are stored in the active profile. The scope of storable settings depends on country and equipment.

- ▶ Unlocking and locking.
- ▶ Lights.
- ▶ Climate control.
- ▶ Radio.
- ▶ Instrument cluster.
- ▶ Programmable memory buttons.
- ▶ Volumes, tone.
- ▶ Control Display.
- ▶ Navigation.
- ▶ PDC Park Distance Control.
- ▶ Rearview camera.

- ▶ Driving Dynamics Control.
- ▶ Intelligent Safety.

Profile management

Selecting a driver profile

Regardless of the remote control in use, a different driver profile may be activated. This allows you to call up personal vehicle settings, even if you did not unlock the vehicle with your own remote control.

Via iDrive:

1. "My Vehicle"
 2. "Driver profiles"
 3. Select driver profile.
 4. "OK"
- ▶ All settings stored in the called-up driver profile are automatically applied.
 - ▶ The called-up driver profile is assigned to the remote control being used at the time.
 - ▶ If the driver profile is already assigned to a different remote control, this driver profile will apply to both remote controls.

Using a guest profile

The guest profile is for individual settings that are stored in none of the three personal driver profiles.

Via iDrive:

1. "My Vehicle"
2. "Driver profiles"
3. "Drive off (guest)"
4. "OK"

The guest profile cannot be renamed. It is not assigned to the current remote control.

Renaming a driver profile

A personal name can be assigned to the active driver profile to avoid confusion between the driver profiles.

Via iDrive:

1. "My Vehicle"
2. "Driver profiles"
3. Select driver profile.
 -  The driver profile marked with this symbol can be renamed.
4. "Change driver profile name"
5. Enter profile name.
6. **OK** Select the symbol.

Resetting a driver profile

The settings of the driver profile currently in use are reset to their factory settings.

Via iDrive:

1. "My Vehicle"
2. "Driver profiles"
3. Select driver profile.
 -  The driver profile marked with this symbol can be reset.
4. "Reset driver profile"
5. "OK"

Exporting driver profiles

Most settings of the active driver profile can be exported.

Exporting is helpful when storing and retrieving personal settings, for instance before delivering the vehicle to a workshop. The stored driver profiles can be taken into another vehicle.

Via iDrive:

1. "My Vehicle"
2. "Driver profiles"
3. Select driver profile.
 -  The driver profile marked with this symbol can be exported.
4. "Export driver profile"
5. Select a storage device for exporting the driver profile.
 - ▶ "USB device"

Select USB storage device, as needed, refer to page 54.

- ▶ Online.

Importing driver profiles

The existing settings of the active driver profile are overwritten with the settings of the imported driver profile.

Via iDrive:

1. "My Vehicle"
2. "Driver profiles"
3. Select the driver profile to be overwritten.
 -  The driver profile marked with this symbol can be overwritten.
4. "Import driver profile"
5. Select a storage device for importing the driver profile.
 - ▶ USB storage device: "USB device"
Select USB storage device as needed.
 - ▶ Online.
6. Select the driver profile to be imported.

Displaying driver profiles during start

The driver profiles can be displayed during each start to select the desired profile.

Via iDrive:

1. "My Vehicle"
2. "Driver profiles"
3. "Show driver profiles at startup"

System limits

A clear assignment between the remote control and driver may not be possible in the following cases, for example.

- ▶ The passenger unlocks the vehicle with his or her own remote control, but another person is driving.



- ▶ The driver unlocks the vehicle via Comfort Access and has multiple remote controls with him or her.
- ▶ The driver changes, but the vehicle is not locked and unlocked.
- ▶ Multiple remote controls are located outside of the vehicle.

Settings

General information

Depending on the vehicle equipment and country version, various settings for opening and closing are possible.

These settings are stored for the driver profile, refer to page 79, currently used.

Unlocking

Doors

Via iDrive:

1. "My Vehicle"
2. "Vehicle settings"
3. "Doors/Key"
4. "Driver's door" or "All doors"
5. Select desired setting:
 - ▶ "Driver's door only"
Only the driver's door is unlocked. Pressing again unlocks the entire vehicle.
 - ▶ "All doors"
The entire vehicle is unlocked.

Confirmation signals from the vehicle

Via iDrive:

1. "My Vehicle"
2. "Vehicle settings"
3. "Doors/Key"
4. Deactivate or activate the desired confirmation signals.

- ▶ "Flash for lock/unlock"
Unlocking is signaled by two flashes, locking by one.
- ▶ With alarm system:
"Acoustic signal for lock/unlock"
Unlocking is signaled by one honk of the horn.

Automatic locking

Via iDrive:

1. "My Vehicle"
2. "Vehicle settings"
3. "Doors/Key"
4. Select desired setting:
 - ▶ "Lock automatically"
The vehicle locks automatically after a short period of time if no door is opened after unlocking.

Automatic unlocking

Via iDrive:

1. "My Vehicle"
2. "Vehicle settings"
3. "Doors/Key"
4. "Unlock at end of trip"
After the engine is switched off by pressing the Start/Stop button, the locked vehicle is automatically unlocked.

Alarm system

General information

When the vehicle is locked, the vehicle alarm system reacts to the following changes:

- ▶ Unauthorized opening of a door, the hood or the tailgate.
- ▶ Movements in the car's interior.



- ▶ Changes in the vehicle tilt, for instance during attempts at stealing a wheel.
- ▶ Disconnected battery voltage.
- ▶ Improper use of the socket for Onboard Diagnosis.

The alarm system signals these changes visually and acoustically:

- ▶ Acoustic alarm:
Depending on local regulations, the acoustic alarm may be suppressed.
- ▶ Visual alarm:
By flashing the exterior lighting.

Switching on/off

When you lock and unlock the vehicle with the remote control or Comfort Access, the alarm system will also switch on or off at the same time.

Opening the doors with the alarm system switched on

The alarm system is triggered when a door is opened if the door was unlocked using the integrated key in the door lock.

Switching off the alarm, refer to page 84.

Opening the tailgate with the alarm system switched on

The tailgate can be opened even when the alarm system is switched on.

After the tailgate is closed, it is locked and monitored again provided the doors are locked. The hazard warning system flashes once.

Panic mode

You can trigger the alarm system if you find yourself in a dangerous situation.



- ▶ Press button on the remote control and hold for at least 3 seconds.
- ▶ Briefly press the button on the remote control three times in succession.

To switch off the alarm: press any button.

Indicator light on the interior mirror

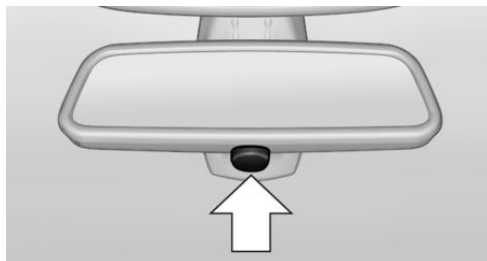

- ▶ The indicator light flashes briefly every 2 seconds:
The alarm system is switched on.
- ▶ Indicator light flashes for approx. 10 seconds, then it flashes briefly every 2 seconds:
Interior motion sensor and tilt alarm sensor are not active, as doors, hood, or tailgate are not correctly closed. Correctly closed access points are secured.
When the still open access points are closed, interior motion sensor and tilt alarm sensor will be switched on.
- ▶ The indicator light goes out after unlocking:
The vehicle has not been tampered with.
- ▶ The indicator light flashes after unlocking until the radio-ready state is switched on, but no longer than approx. 5 minutes:
An alarm has been triggered.

Tilt alarm sensor

The tilt of the vehicle is monitored.

The alarm system responds in situations such as attempts to steal a wheel.

Interior motion sensor

The windows and the glass sunroof must be closed for the system to function properly.



Avoiding unintentional alarms

General information

The tilt alarm sensor and interior motion sensor can trigger an alarm, although no unauthorized action occurred.

Possible situations for an unwanted alarm:

- ▷ In automatic vehicle washes.
- ▷ In duplex garages.
- ▷ During transport on trains carrying vehicles, at sea or on a trailer.
- ▷ With animals in the vehicle.
- ▷ At the gas station: if the vehicle is locked after refueling starts.

The tilt alarm sensor and the interior motion sensor can be switched off in such situations.

Switching off the tilt alarm sensor and interior motion sensor



Press the remote control button again within 10 seconds as soon as the vehicle is locked.

The indicator light lights up for approx. 2 seconds and then continues to flash.

The tilt alarm sensor and interior motion sensor are switched off until the vehicle is locked again.

Switching off the alarm

- ▷ Unlock the vehicle with the remote control or establish radio-ready state, if needed through emergency detection of remote control, refer to page 73.
- ▷ With Comfort Access:
If you are carrying the remote control on your person, grasp the door handle on the driver's or front passenger door completely.

Power windows

Safety information

WARNING



When operating the windows, body parts and objects can be jammed. There is a risk of injury or risk of damage to property. Make sure that the area of movement of the windows is clear during opening and closing.

Overview



Power windows

Opening

- ▷  Press the switch to the resistance point.
The window opens while the switch is being held.
- ▷  Press the switch beyond the resistance point.
The window opens automatically. Pressing the switch again stops the motion.

Convenient opening via the remote control, refer to page 71.

Closing

- ▷  Pull the switch to the resistance point.

The window closes while the switch is being held.

- ▶  Pull the switch beyond the resistance point.

The window closes automatically if the door is closed. Pulling again stops the motion.

Closing via Comfort Access, refer to page 76.

Jam protection system

General information

If closing force exceeds a specific threshold as a window closes, closing is interrupted.

The window opens slightly.

Safety information

WARNING

Accessories on the windows such as antennas can impact jam protection. There is a risk of injury. Do not install accessories in the area of movement of the windows.

Closing without the jam protection system

In case of danger from the outside or if ice might prevent normal closing, proceed as follows:

1.  Pull the switch past the resistance point and hold it there.

The window closes with limited jam protection. If the closing force exceeds a specific threshold, closing is interrupted.

2.  Pull the switch past the resistance point again within approx. 4 seconds and hold it there.

The window closes without jam protection.

Glass sunroof, electric

General information

The glass sunroof is ready for operation when standby state is switched on.

Safety information

WARNING

Body parts can be jammed when operating the glass sunroof. There is a risk of injury. Make sure that the area of movement of the glass sunroof is clear during opening and closing.

Overview



Tilting the glass sunroof

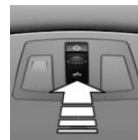

Push switch briefly upward.

- ▶ The closed glass sunroof tilts.
- ▶ The opened glass sunroof closes until it is in the tilted position. The sun protection does not move.

Opening/closing the glass sunroof and sun protection

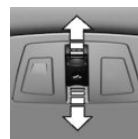

- ▶ Press the switch in the desired direction to the resistance point and hold it there.



The glass sunroof moves as long as the switch is held down.

- ▶ Press the switch in the desired direction past the resistance point.
The glass sunroof moves automatically.
Pressing the switch upward stops the motion.
- ▶ Opening and closing the sun protection manually.

Convenient opening via the remote control, refer to page 71.

Closing via Comfort Access, refer to page 76.

Comfort position

In some models, the wind noises in the car's interior are lowest when the glass sunroof is not fully open. In these models, the automatic function initially only opens the glass sunroof up to this comfort position.

Pressing the switch again opens the glass sunroof fully.

Jam protection system

General information

If the closing force exceeds a certain value when closing the glass sunroof, the closing operation is interrupted once the roof reaches the half-open position. The glass sunroof opens slightly.

Closing from the open position without jam protection

If there is an external danger, proceed as follows:

1. Push the switch forward past the resistance point and hold.

The glass sunroof closes with limited jam protection. If the closing force exceeds a specific threshold, closing is interrupted.

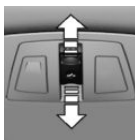

2. Push the switch forward again past the resistance point and hold until the glass sunroof closes without jam protection. Make sure that the closing area is clear.

Closing from the raised position without jam protection

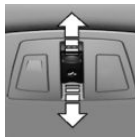

If there is an external danger, push the switch forward past the resistance point and hold it.

The glass sunroof closes without jam protection.

Initializing after a power interruption

General information

After a power failure during the opening or closing process, the glass sunroof can only be operated to a limited extent.

The system can be initialized under the following conditions.

- ▶ The vehicle is parked in a horizontal position.
- ▶ The drive-ready state is established.
- ▶ The external temperature is above 41 °F/5 °C.

During initialization, the glass sunroof closes without jam protection.

Make sure that the closing area is clear.



Initializing the system



Press the switch up and hold it until initialization is complete.

Initialization begins within 15 seconds.

- ▶ If the glass sunroof is closed, it opens then closes again.
- ▶ If the glass sunroof is open, it first closes, then opens and closes again.

Initialization is complete once the glass sunroof has opened then closed again.



Seats, mirrors, and steering wheel

Vehicle features and options

This chapter describes all standard, country-specific and optional features offered with the series. It also describes features that are not necessarily available in your vehicle, e. g., due to the selected options or country versions. This also applies to safety-related functions and systems. When using these functions and systems, the applicable laws and regulations must be observed.

Sitting safely

An ideal seating position that meets the needs of the occupants can make a vital contribution to relaxed, fatigue-free driving.

In the event of an accident, the correct seating position plays an important role. Additionally, follow the following chapters for safe driving:

- ▶ Seats, refer to page 88.
- ▶ Safety belts, refer to page 90.
- ▶ Head restraints, refer to page 91.
- ▶ Airbags, refer to page 133.

Seats

Safety information

WARNING

Seat adjustments while driving can lead to unexpected movements of the seat. Vehicle control could be lost. There is a risk of an accident. Only adjust the seat on the driver's side when the vehicle is stationary.

WARNING

With a backrest inclined too far to the rear, the efficacy of safety gear, including safety belts can no longer be ensured. There is a risk of sliding under the safety belt in an accident. There is a risk of injuries or danger to life. Adjust the seat prior to starting the trip. Adjust the backrest so that it is in the most upright position as possible and do not adjust again while driving.

WARNING

There is a risk of jamming when moving the seats. There is a risk of injury or risk of damage to property. Make sure that the area of movement of the seat is clear prior to any adjustment.

Adjusting seats

Overview



- 1 Forward/backward
- 2 Height
- 3 Backrest tilt

Forward/backward

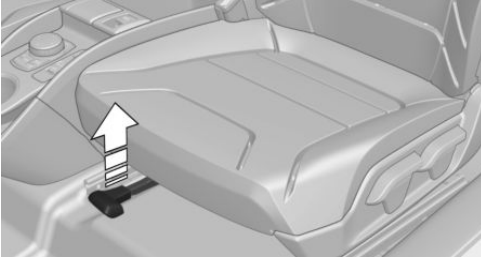

Pull the lever and slide the seat in the desired direction.

After releasing the lever, move the seat forward or back slightly making sure it engages properly.

Height

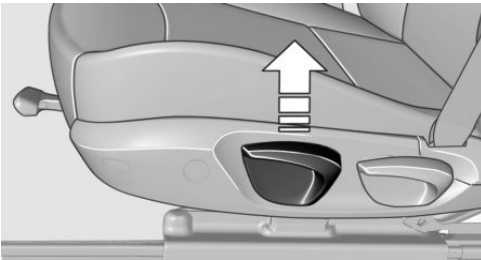

Pull the lever and apply your weight to the seat or lift it off, as necessary.

Backrest tilt



Pull the lever and apply your weight to the backrest or lift it off, as necessary.

Assistance with entering the vehicle in the rear

Safety information

WARNING

There is a risk of jamming when moving the seats. There is a risk of injury or risk of damage to property. Make sure that the area of movement of the seat is clear prior to any adjustment.

WARNING

Unexpected movements of the backrest while driving may occur due to an unlocked backrest. Vehicle control could be lost. There is a risk of injury. Fold back and lock the backrests before driving.

Folding down the backrest

1. Pull lever up to the stop.

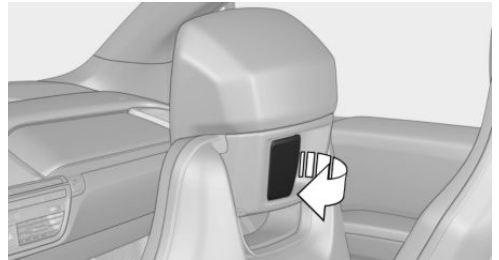

2. Fold backrest forward.

Backrest returns to its initial position after release.



Front seat heating

Overview



Seat heating

Switching on



Press button once for each temperature level.

The maximum temperature is reached when three LEDs are lit.

If the trip is continued within approx. 15 minutes after a stop, seat heating is activated automatically with the temperature selected last.

If ECO PRO+ is activated, refer to page 205, the seat heating is deactivated.

Switching off



Press and hold the button, until the LEDs go out.

Safety belts

Number of safety belts and safety belt buckles

The vehicle is fitted with four safety belts to ensure occupant safety. However, they can only offer protection when adjusted correctly.

General information

Always make sure that safety belts are being worn by all occupants before driving off. Although airbags enhance safety by providing added protection, they are not a substitute for safety belts.

The upper shoulder strap's anchorage point will be correct for adult seat occupants of every build if the seat is correctly adjusted.

Safety information

WARNING

Use of a safety belt to buckle more than one person will potentially defeat the ability of the safety belt to serve its protective function. There is a risk of injuries or danger to life. Do not allow more than one person to wear a single safety belt. Infants and children are not allowed on an occupant's lap, but must be transported and secured in designated child restraint systems.

WARNING

The efficacy of safety gear, including safety belts, can be limited or lost when safety belts are fastened incorrectly. An incorrectly fastened safety belt can cause additional injuries, for instance in the event of an accident or during braking and evasive maneuvers. There is a risk of injuries or danger to life. Make sure that all occupants are wearing safety belts correctly.

WARNING

The efficacy of safety gear, including safety belts, may not be fully functional or fail in the following situations:

- ▷ The safety belts or safety belt buckles are damaged, soiled, or changed in any other way.



- ▷ Belt tensioners or belt retractors were modified.

Safety belts can be imperceptibly damaged in the event of an accident. There is a risk of injuries or danger to life. Do not modify safety belts, safety belt buckles, belt tensioners, belt retractors or belt anchors and keep them clean. Have the safety belts checked after an accident at the dealer's service center or another qualified service center or repair shop.

Correct use of safety belts

- ▷ Wear the safety belt twist-free and tight to your body over your lap and shoulders.
- ▷ Wear the safety belt deep on your hips over your lap. The safety belt may not press on your stomach.
- ▷ Do not rub the safety belt against sharp edges, or guide it or jam it in across hard or fragile objects.
- ▷ Avoid thick clothing.
- ▷ Re-tighten the safety belt frequently upward around your upper body.

Buckling the safety belt

1. Slowly guide the safety belt out of the holder when fastening it.
2. Insert the tongue plate into the safety belt buckle. The safety belt buckle must engage audibly.

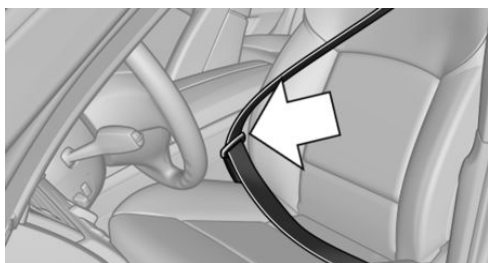

Unbuckling the safety belt

1. Hold the safety belt firmly.

2. Press the red button in the belt buckle.
3. Guide the safety belt back into its roll-up mechanism.

Safety belt reminder for driver's and passenger's seat

Display in the instrument cluster



The indicator light lights up and a signal sounds. Make sure that the safety belts are positioned correctly. The safety belt reminder can also be activated if objects are placed on the front passenger seat.

Front head restraints

Safety information

WARNING

A missing protective effect due to removed or not correctly adjusted head restraints can cause injuries in the head and neck area. There is a risk of injury.

- ▷ Before driving, install the removed head restraints on the occupied seats.
- ▷ Adjust the head restraint so its center supports the back of the head at as close to eye level as possible.
- ▷ Adjust the distance so that the head restraint is as close as possible to the back of the head. Adjust the distance via the backrest tilt as needed.

WARNING

Objects on the head restraint reduce the protective effect in the head and neck area. There is a risk of injury.

- ▷ Do not use seat or head restraint covers.
- ▷ Do not hang objects, for instance clothes hangers, directly on the head restraint.



- ▷ Only use accessories that have been determined to be safe for attachment to a head restraint.
- ▷ Do not use any accessories, for instance pillows, while driving.

Adjusting the height

The height of the head restraints cannot be adjusted.

Distance

The spacing is adjusted to the back of the head using the incline of the seat backrest.

Adjust the distance so that the head restraint is as close as possible to the back of the head.

Removing

The head restraints cannot be removed.

Rear head restraints

Safety information

WARNING

A missing protective effect due to removed or not correctly adjusted head restraints can cause injuries in the head and neck area. There is a risk of injury.

- ▷ Before driving, install the removed head restraints on the occupied seats.
- ▷ Adjust the head restraint so its center supports the back of the head at as close to eye level as possible.
- ▷ Adjust the distance so that the head restraint is as close as possible to the back of the head. Adjust the distance via the backrest tilt as needed.

WARNING

Body parts can be jammed when moving the head restraint. There is a risk of injury. Make sure that the area of movement is clear when moving the head restraint.

WARNING

Objects on the head restraint reduce the protective effect in the head and neck area. There is a risk of injury.

- ▷ Do not use seat or head restraint covers.
- ▷ Do not hang objects, for instance clothes hangers, directly on the head restraint.
- ▷ Only use accessories that have been determined to be safe for attachment to a head restraint.
- ▷ Do not use any accessories, for instance pillows, while driving.

Height

Settings

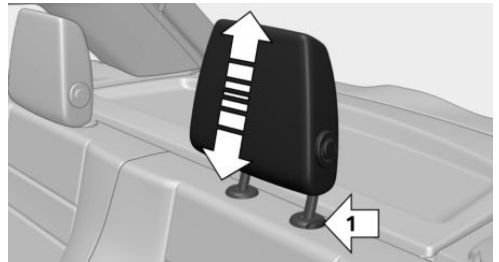

- ▷ To lower: press the button, arrow 1, and push the head restraint down.
 - ▷ To raise: push the head restraint up.
- After setting the height, move the head restraint up or down slightly, making sure it engages properly.

Folding down the head restraint

Only fold the head restraint back if no one will be sitting in the seat in question.

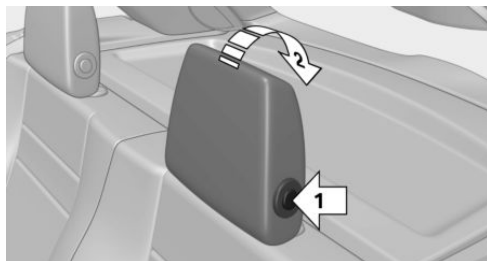

- ▶ To the back: press the button, arrow 1, and fold the head restraint back, arrow 2.
- ▶ Forward: fold the head restraint toward the front as far as it will go. Make sure that the head restraint engages correctly.

Removing

Only remove the head restraint if no one will be sitting in the seat in question.

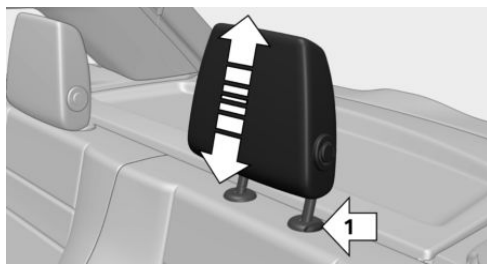

1. Fold down the rear seat backrest, refer to page 189.
2. Raise the head restraint up against the resistance.
3. Press the button, arrow 1, and pull the head restraint out completely.

Installing

Proceed in the reverse order to install the head restraint.

Mirrors

Exterior mirrors

General information

The mirror on the front passenger side is more curved than the driver's side mirror.

Safety information

WARNING

Objects reflected in the mirror are closer than they appear. The distance to the traffic behind could be incorrectly estimated, for instance while changing lanes. There is a risk of an accident. Estimate the distance to the traffic behind by looking over your shoulder.

Overview



- 1 Settings
- 2 Selecting a mirror, Automatic Curb Monitor, automatic cornering adjustment
- 3 Folding in and out

Selecting a mirror



To change over to the other mirror:
Slide the switch.



Adjusting electrically



Press button.

The mirror movement follows the button movement.

Malfunction

In case of an electrical malfunction, adjust the mirror by pressing the edges of the mirror glass.

Automatic cornering adjustment

Concept

During right-hand turns, the mirror glass is turned. Provides a better view of the vehicle sideways.

Safety information

WARNING

The system cannot serve as a substitute for the driver's personal judgment in assessing visibility and traffic situation. There is a risk of an accident. Adjust driving style to traffic conditions. Watch traffic closely and actively intervene where appropriate.

Functional requirements

- ▶ Vehicle moving.
- ▶ Speed less than 12 mph/20 km/h.
- ▶ Turn signal is set.

Activating



Slide the switch to the driver's side mirror position.

Deactivating



Slide the switch to the passenger's side mirror position.

Folding in and out

NOTE

Depending on the vehicle width, the vehicle can be damaged in vehicle washes. There is a risk of damage to property. Before washing, fold in the mirrors by hand or with the button.



Press button.

Folding is only possible up to a speed of approx. 15 mph/20 km/h.

Folding the mirrors in and out is helpful in the following situations:

- ▶ In vehicle washes.
- ▶ On narrow roads.

Mirrors that were folded in are folded out automatically at a speed of approx. 25 mph/40 km/h.

Automatic heating

Both exterior mirrors are automatically heated whenever drive-ready state is switched on.

Automatic dimming feature

The exterior mirror on the driver's side is automatically dimmed. Photocells in the interior mirror are used to control this.

Automatic Curb Monitor, exterior mirror

Concept

If reverse gear is engaged, the mirror glass on the front passenger side is tilted downward. This improves your view of the curb and other low-lying obstacles when parking, for instance.

Activating

1.  Slide the switch to the driver's side mirror position.
2. Engage selector lever position R.



Deactivating

 Slide the switch to the passenger's side mirror position.

Interior mirror, manually dimmable

Flip lever

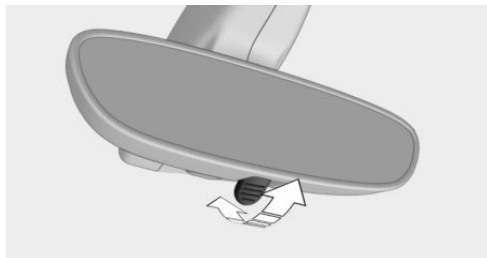

To reduce the blinding effect of the interior mirror, flip the lever forward.

Interior mirror, automatic dimming feature

Overview

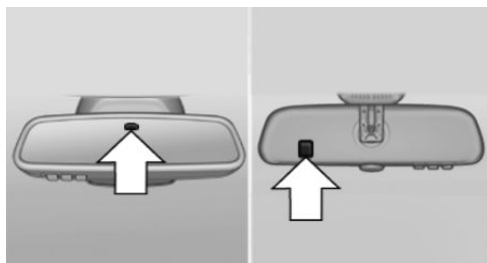

Photocells are used for control:

- In the mirror glass.
- On the back of the mirror.

Functional requirements

- Keep the photocells clean.
- Do not cover the area between the interior mirror and the windshield.

Steering wheel

Safety information

WARNING

Steering wheel adjustments while driving can lead to unexpected steering wheel movements. Vehicle control could be lost. There is a risk of an accident. Adjust the steering wheel while the vehicle is stationary only.

Settings

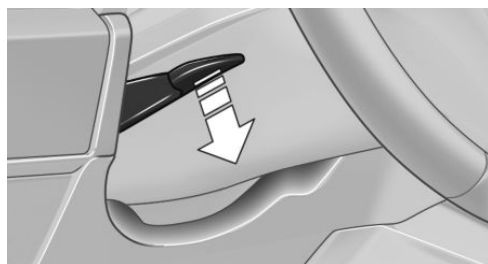

1. Fold the lever down.
2. Move the steering wheel to the preferred height and angle to suit your seating position.
3. Fold the lever back up.



Transporting children safely

Vehicle features and options

This chapter describes all standard, country-specific and optional features offered with the series. It also describes features that are not necessarily

available in your vehicle, e. g., due to the selected options or country versions. This also applies to safety-related functions and systems. When using these functions and systems, the applicable laws and regulations must be observed.

The right place for children

Safety information

WARNING

Unattended children or animals can cause the vehicle to move and endanger themselves and traffic, for instance due to the following actions:

- ▷ Pressing the Start/Stop button.
- ▷ Releasing the parking brake.
- ▷ Opening and closing the doors or windows.
- ▷ Engaging selector lever position N.
- ▷ Using vehicle equipment.

There is a risk of accidents or injuries. Do not leave children or animals unattended in the vehicle. Take the remote control with you when exiting and lock the vehicle.

no longer be used due to their age, weight, and size.

Safety information

WARNING

The safety belt cannot be fastened correctly on children shorter than 5 ft, 150 cm without suitable additional child restraint systems. The efficacy of safety gear, including safety belts, can be limited or lost when safety belts are fastened incorrectly. An incorrectly fastened safety belt can cause additional injuries, for instance in the event of an accident or during braking and evasive maneuvers. There is a risk of injuries or danger to life. Secure children shorter than 5 ft, 150 cm using suitable child restraint systems.

Always transport children in the rear seat

General information

Accident research shows that the safest place for children is in the rear seat.

Transport children younger than 13 years of age or shorter than 5 ft/150 cm only in the rear seat in suitable child restraint systems designed for the age, weight and size of the child. Children 13 years of age or older must wear a safety belt as soon as a suitable child restraint system can

Children on the front passenger seat

General information

Should it ever be necessary to use a child restraint system in the front passenger seat, make sure that the front, knee and side airbags on the front passenger side are deactivated. Automatic deactivation of front-seat passenger airbags, refer to page 135.

Safety information

WARNING

Active front-seat passenger airbags can injure a child in a child restraint system when the airbags are activated. There is a risk of injury. Make sure that the front-seat passenger airbags are deactivated and that the PASSENGER AIRBAG OFF indicator light lights up.

WARNING

The stability of the child restraint system is limited or compromised with incorrect seat adjustment or improper installation of the child seat. There is a risk of injuries or danger to life. Make sure that the child restraint system fits securely against the backrest. If possible, adjust the backrest tilt for all affected backrests and correctly adjust the seats. Make sure that seats and backrests are securely engaged or locked. If possible, adjust the height of the head restraints or remove them.

Installing child restraint systems

Safety information

WARNING

The stability of the child restraint system is limited or compromised with incorrect seat adjustment or improper installation of the child seat. There is a risk of injuries or danger to life. Make sure that the child restraint system fits securely against the backrest. If possible, adjust the backrest tilt for all affected backrests and correctly adjust the seats. Make sure that seats and backrests are securely engaged or locked. If possible, adjust the height of the head restraints or remove them.

WARNING

The protective effect of damaged child restraint systems or of child restraint systems exposed to an accident and their fastening systems can be limited or lost. A child can e.g., not sufficiently restrained, for instance in the event of an accident or braking and evasive maneuvers. There is a risk of injuries or danger to life. Have damaged child restraint systems or of child restraint systems exposed to an accident and their fastening systems checked and possibly replaced by the dealer's service center or another qualified service center or repair shop.

On the front passenger seat

Deactivating airbags

WARNING

Active front-seat passenger airbags can injure a child in a child restraint system when the airbags are activated. There is a risk of injury. Make sure that the front-seat passenger airbags are deactivated and that the PASSENGER AIRBAG OFF indicator light lights up.

After installing a child restraint system in the front passenger seat, make sure that the front, knee and side airbags on the front passenger side are deactivated.

Deactivate the front-seat passenger airbags automatically, refer to page 135.

Seat position and height

Before installing a child restraint system, move the front passenger seat as far back as possible and bring it as far up as possible to obtain the best possible position for the belt and to offer optimal protection in the event of an accident.

If the upper anchorage of the safety belt is located in front of the belt guide of the child seat, move the front passenger seat carefully forward



until the best possible belt guide position is reached.

Child seat security



The rear safety belts and the front passenger safety belt can be permanently locked to fasten child restraint systems.

Locking the safety belt

1. Pull out the belt strap completely.
2. Secure the child restraint system with the safety belt.
3. Allow the belt strap to be pulled in and pull it tight against the child restraint system. The safety belt is locked.

Unlocking the safety belt

1. Unbuckle the safety belt buckle.
2. Remove the child restraint system.
3. Allow the belt strap to be pulled in completely.

LATCH child restraint fixing system

General information

LATCH: Lower Anchors and Tether for Children. Pay attention to the operating and safety information of the child restraint system manufacturer when installing and using LATCH child restraint fixing systems.

Mounts for the lower LATCH anchors



The lower anchors may be used to attach the CRS to the vehicle seat up to a combined child and CRS weight of 65 lb/30 kg when the child is restrained by the internal harnesses.

Safety information

WARNING

If the LATCH child restraint fixing systems are not correctly engaged, the protective effect of the LATCH child restraint fixing system can be limited. There is a risk of injuries or danger to life. Make sure that the lower anchors are securely engaged and that the LATCH child restraint fixing system fits securely against the backrest.

Position

Symbol	Meaning
	The corresponding symbol shows the mounts for the lower LATCH anchors.
 ISO FIX	Seats equipped with lower anchors are marked with a pair, 2, of LATCH symbols.

Before installing LATCH child restraint fixing systems

Pull the safety belt away from the area of the child restraint system.

Assembly of LATCH child restraint fixing systems

1. Install child restraint system, see manufacturer's information.
2. Ensure that both LATCH anchors are properly connected.



Child restraint systems with tether strap

Safety information

WARNING

If the upper retaining strap is incorrectly used for the child restraint system, the protective effect can be reduced. There is a risk of injury. Make sure that the upper retaining strap is not guided across sharp edges and without twisting to the upper retaining strap.

WARNING

If the rear backrest is not locked, the protective effect of the child restraint system is limited or there is none. In particular situations, for instance braking maneuvers or in case of an accident, the rear backrest can fold forward. There is a risk of injuries or danger to life. Make sure that the rear backrests are locked.

NOTE

The anchors for the upper retaining straps of child restraint systems are only provided for these retaining straps. When other objects are mounted, the anchors can be damaged. There is a risk of damage to property. Only mount child restraint systems to the upper retaining straps.

Anchors



The respective symbol shows the anchor for the upper retaining strap. Seats with an upper top tether are marked with this symbol. It can be found on the rear seat backrest or the rear window shelf.

Routing the retaining strap

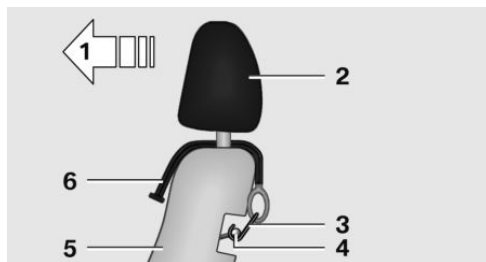

- 1 Direction of travel
- 2 Head restraint
- 3 Hook for upper retaining strap
- 4 Anchor
- 5 Seat backrest
- 6 Upper retaining strap

Attaching the upper retaining strap to the anchor

1. Raise the head restraint, if needed.
2. Guide the upper retaining strap between or along both sides of the supports of the head restraint to the anchor.
3. If there is a retaining strap, run it between the backrest and the cargo cover.
4. Attach the hook of the retaining strap to the anchor.
5. Tighten the retaining strap by pulling it down.
6. Lower and lock head restraints as needed.



Driving

Vehicle features and options

This chapter describes all standard, country-specific and optional features offered with the series. It also describes features that are not necessarily available in your vehicle, e. g., due to the selected options or country versions. This also applies to safety-related functions and systems. When using these functions and systems, the applicable laws and regulations must be observed.

Start/Stop button

Overview

Button in the vehicle

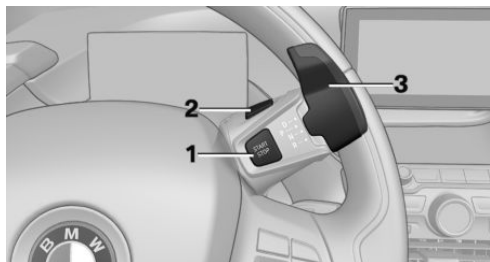

- 1 Start/Stop button
- 2 Park P
- 3 Selector lever

Concept



Pressing the Start/Stop button switches standby state on or off. Drive-ready state is switched on when you depress the brake pedal while pressing the Start/

Stop button.

Pressing the Start/Stop button again switches drive-ready state back off and radio-ready state is switched back on.

The drive-ready state cannot be activated as long as the charging cable is connected, refer to page 210.

Radio-ready state

Some electronic systems/power consumers are ready for operation.

The radio-ready state is switched off automatically:

- ▶ If the driver's or front passenger door is opened when exiting the vehicle, with drive-ready state switched off manually.
- ▶ After approx. 8 minutes.
- ▶ When the vehicle is locked using the central locking system.
- ▶ If the charge state of the batteries is low.

The radio-ready state remains active if, for instance drive-ready state is automatically switched off for the following reasons:

- ▶ Opening or closing the driver's door.
- ▶ Unfastening of the driver's safety belt.
- ▶ When automatically switching from low beams to parking lights.

Radio-ready state is also switched back on if the on/off button on the radio is pressed when the vehicle is parked.

If drive-ready state is switched on: the system automatically switches to radio-ready state when the driver's door is opened and the driver's safety belt is unbuckled if the lights are switched off or the daytime running lights are switched on.



Standby state

All electronic systems/power consumers are ready for operation. Odometer and trip odometer are displayed in the instrument cluster.

To preserve the battery, use standby state and activated power features only as long as absolutely necessary.

Turning on standby state

Pressing the Start/Stop button switches standby state on or off.

Standby state is switched off automatically:

- ▶ When locking the vehicle, even if the low beams are switched on.
- ▶ When opening or closing the driver door, if the driver's safety belt is unbuckled and the low beams are switched off.
- ▶ While the driver's safety belt is unbuckled with driver's door open and low beams off.
- ▶ When the batteries' state of charge is low, if the low beams are switched off.
- ▶ The low beams switch to parking lights after approx. 15 minutes of no use.
- ▶ When the front doors are opened if there is no other person sitting in the front seats.

Drive-ready state

Activated drive-ready state is the equivalent of a running engine in conventional vehicles. Deactivated drive-ready state is equivalent to switching the ignition off.

If drive-ready state is switched on, the vehicle ready to drive and the READY signal, refer to page 101, is displayed in the instrument cluster.

All vehicle systems are ready for operation.

Most of the indicator/warning lights in the instrument cluster light up for a varied length of time.

To save battery power when parking, switch off drive-ready state and any unnecessary electronic systems/power consumers.

The drive-ready state is switched off automatically if the driver's safety belt is not buckled when the driver's door is opened.

Safety information

NOTE

Selector lever position P is automatically engaged when drive-ready state is switched off. There is a risk of damage to property. Do not switch drive-ready state off in vehicle washes.

Drive-ready state in detail

Safety information

WARNING

An unsecured vehicle can begin to move and possibly roll away. There is a risk of an accident. Before exiting, secure the vehicle against rolling.

In order to ensure that the vehicle is secured against rolling away, follow the following:

- ▶ Set the parking brake.
- ▶ On uphill grades or on a downhill slope, turn the front wheels in the direction of the curb.
- ▶ On uphill grades or on a downhill slope, also secure the vehicle, for instance with a wheel chock.

Switching on drive-ready state

1. Close the driver's door.
2. Depress the brake pedal.
3. Press the Start/Stop button.

Drive-ready state is switched on.



Display in the instrument cluster



The READY display indicates that the vehicle is ready for driving.

Display on the Start/Stop button

General information

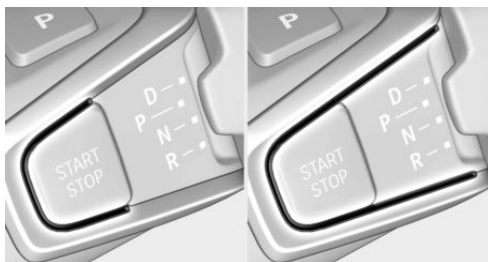

Drive-ready state is also displayed through light indicators on the Start/Stop button.

Lighting pulses orange

- ▶ After unlocking and opening the door.
- ▶ After switching off drive-ready state.

When the brake pedal is depressed, the lighting becomes more intense.

Lighting lights up steady blue

After drive-ready state is switched on, light turns blue. The vehicle is ready to drive. The READY indicator lights up in the instrument cluster. In addition, a signal sounds.

Lighting off

Drive-ready state, standby state and radio-ready state are switched off. The vehicle is in the idle state. The charging cable may be connected.

Driving off

Functional requirements

Driving is possible under the following conditions:

- ▶ The high-voltage battery is sufficiently charged.
- ▶ The driver's door is closed.

State of charge in strong temperature fluctuations

In the case of strong temperature fluctuations and a low state of charge of the high-voltage battery, it may not be possible to start the vehicle again at the beginning of the next trip. Recharge vehicle with low state of charge in time.

Driving

1. Switch on drive-ready state.
2. Apply the brake and engage the selector lever in position D or R.
3. Release the parking brake.
4. Depress the accelerator pedal to drive.

Selector lever positions

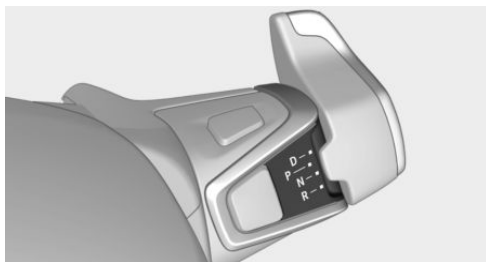

The engaged selector lever position is displayed on the selector lever.

D Drive

Position for normal vehicle operation.



Reverse R

Select only when the vehicle is stationary.

N is Neutral

The vehicle may be pushed or roll without power, for instance in vehicle washes, refer to page 103, in selector lever position N.

P Park

Engage only while the vehicle is stationary and the brake is applied. The drive wheels are blocked.

Selector lever position P is engaged automatically in the following situations:

- ▶ If the driver's safety belt is off, the driver's door is open and neither brake nor accelerator pedal are depressed while drive-ready state is switched on and selector lever position D or R is set.
- ▶ After switching off drive-ready state via the Start/Stop button, if selector lever position D or R is set.
- ▶ With standby state switched off.

Before exiting the vehicle, make sure that selector lever position P is set. Otherwise, the vehicle may begin to move. On uphill grades, also Set parking brake, refer to page 107.

Engaging selector lever positions

General information

- ▶ Interlock: the selector lever position P can be exited only with drive-ready state engaged.
- ▶ Shift lock: with the vehicle stationary, press on the brake pedal before shifting out of P or N; otherwise, the shift command will not be executed.
- ▶ Shift lock: before shifting out of P, remove the charging cable from the vehicle; otherwise, the shift command will not be executed.

Engage D, N, R

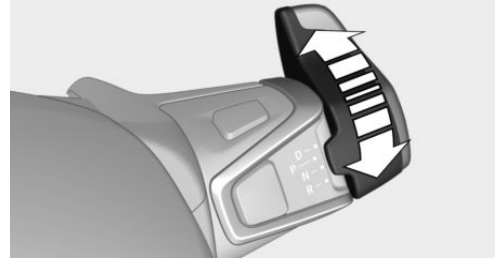

Turn the selector lever in the desired direction. The engaged selector lever position is displayed on the selector lever.

Engaging P

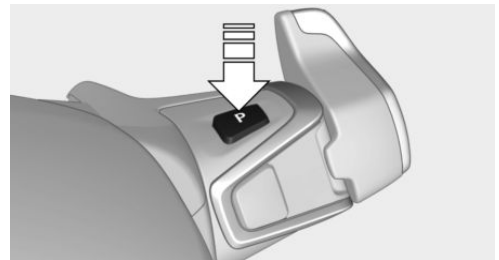

Press button P.

Rolling or pushing the vehicle

General information

In some situations, the vehicle is to roll without its own power for a short distance, for instance in a vehicle wash, or be pushed.

Engaging selector lever position N

1. Switch on drive-ready state while pressing on the brake pedal.
2. If necessary, release the parking brake.
3. Depress the brake pedal.
4. Engage selector lever position N.
5. Switch off drive-ready state.



In this way, standby state remains switched on, and a Check Control message is displayed.

The vehicle may roll.

NOTE

Selector lever position P is automatically engaged when standby state is switched off. There is a risk of damage to property. Do not switch standby state off in vehicle washes.

Irrespective of standby state, the selector lever position P is automatically engaged after approx. 15 minutes.

If there is a malfunction, you may not be able to change the selector lever position.

Electronically unlock the transmission lock, if needed.

Electronic unlocking of the transmission lock

General information

Electronically unlock the transmission lock to maneuver vehicle from a danger area.

Before unlocking the transmission lock, set the parking brake to prevent the vehicle from rolling away.

Engaging selector lever position N

1. Hold the Start/Stop button pressed.
2. Depress the brake pedal.
3. Turn and hold the selector lever in position N.
A corresponding Check Control message is displayed.
4. Turn the selector lever again into position N within approx. 2 seconds.
Position N is indicated on the selector lever.
5. Release Start/Stop button and brake.
6. Maneuver the vehicle from the danger area and secure it against moving on its own.

Switching off drive-ready state

Park the vehicle. Noises from the electrical system such as for cooling the high-voltage system might still be audible.

After stopping the vehicle:

1. Apply brake and engage the selector lever in position P P.
2. Set the parking brake.
3. Press the Start/Stop button.

The READY indicator goes out and a signal sounds.

In case of longer idle times, follow the instructions in the Care chapter, refer to page 262.

Driving in detail: eDRIVE

Safety information

DANGER

The braking power of the electric motor can be stronger than for a vehicle with combustion engine. Abrupt braking and slow-down may confuse other traffic. There is a risk of an accident. Carefully release the accelerator pedal. Adjust driving style to traffic conditions. Watch traffic closely and actively intervene where appropriate.

WARNING

When driving in electric mode, pedestrians and other traffic might pay less attention to the vehicle due to the lack of engine noise. There is a risk of an accident. Adjust driving style to traffic conditions. Watch traffic closely and actively intervene where appropriate.

⚠ WARNING

Without energy recovery, there is no braking power of the electric motor available. The vehicle could roll further than anticipated. There is a risk of an accident. Adjust driving style to traffic conditions. Watch traffic closely and actively intervene where appropriate.

Accelerator pedal positions

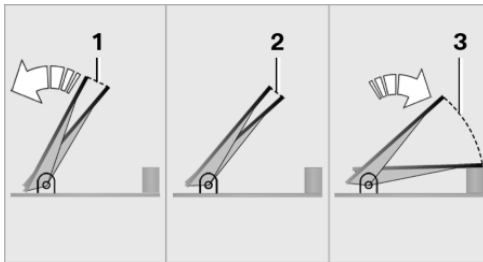

- 1 Deceleration
- 2 Coasting
- 3 Acceleration or constant speed: ePOWER

Deceleration

The deceleration depends on the position of the accelerator pedal. The less the actuation of the accelerator pedal, the greater the deceleration. In this way energy is recovered and the high-voltage battery is charged.

Releasing the accelerator pedal causes deceleration similar to cautious braking. Additionally, the brake lights will come on without hitting the brakes.

Energy recovery: CHARGE

The high-voltage battery is recharged in part through energy recovery. The electric motor acts as a generator when decelerating and converts the kinetic energy into electrical energy.

Energy can be recovered if the following conditions are met:

- ▷ The vehicle is moving.
- ▷ Speed higher than approx. 12 mph/20 km/h.
- ▷ Selector lever position D or R is set.
- ▷ Accelerator pedal is not actuated or only pressed down one third of the way.

Energy cannot be recovered in the following situations:

- ▷ Selector lever position N is set.
- ▷ While drive stability control systems, for instance DTC, are active and controlling the vehicle, even though this is not indicated by an indicator light.
- ▷ The high-voltage battery is fully charged.
- ▷ When temperature of the high-voltage battery is very low or very high.

In winter it might be possible that the energy recovery is temporarily unavailable after startup.

Exemplary traffic situations

If a deceleration operation is foreseeable while driving, this can be used for energy recovery.

The following exemplary driving situations may be suitable:

- ▷ Decelerating downhill.
- ▷ Deceleration before a red light.

Avoid late or abrupt braking. Instead, decelerate the vehicle using energy recovery.

Coasting

The electric drive makes it possible to roll without consuming energy. This driving condition is referred to as coasting.

Proactive driving reduces energy consumption and increases the range.

With vehicle rolling, no energy is recovered.

Exemplary traffic situations

If a route can be traveled without anticipated need for braking, it is advantageous to roll.



The following exemplary driving situations may be suitable:

- ▶ Rolling on a straight downhill route without obstacles.
- ▶ Coasting on a route without obstacles.

Avoid late or abrupt braking.

Acoustic pedestrian protection

Concept

Depending on the country-specific version, the system generates a continuous driving noise during electric driving up to approx. 20 mph/30 km/h.

A speaker system broadcasts the noise to the surroundings.

As a result, other traffic participants, for instance pedestrians or cyclists, can better perceive the vehicle.

Range Extender

Increasing the range

If the charge state of the high-voltage battery drops during travel to a minimum value, the Range Extender starts and supplies the required electrical energy for driving on.

☒ The symbol on the charge state indicator designates a Range Extender activation time.

The Range Extender controls its output automatically, turns itself off and restarts according to the driving situation.

If Range Extender is activated, the current charge state of the high-voltage battery is maintained. If necessary, the Range Extender charges the high-voltage battery until the charge state at the time of the activation of the Range Extender has been reached.

The Range Extender has no direct connection to the drive train.

Using the Range Extender

Purely electric use of the vehicle offers the full performance capability of the drive and the most efficient use of the vehicle.

Range Extender is designed to enable further driving in situations, in which the purely electric range is not sufficient. E.g., the next charging station can be reached.

With a very low charge state of the high-voltage battery, the drive power is reduced on sharp uphill grades or at high speeds in order to allow further driving.

This avoids a complete discharge of the high-voltage battery.

A Check Control message indicates an upcoming reduction in drive power. The power reduction is displayed in the performance display, refer to page 116.

Automatic maintenance run

Avoid having long periods when the Range Extender is not used. To ensure functional reliability, the Range Extender is automatically activated at certain intervals for a few minutes while driving. Respective Check Control messages indicate the maintenance run. If the maintenance run of the Range Extender is occurring at an unfavorable time, it can be canceled by pressing the Start/Stop button. It postpones the maintenance run.

Should the high-voltage battery be fully charged or if there is not enough gas in the tank then a maintenance run will not be executed.

Heavily discharged high-voltage battery

If the high-voltage battery is heavily discharged during the trip, the performance and some comfort features are reduced step-by-step to extend the range.

Heated high-voltage battery

With a stationary vehicle

In exceptional cases, it is possible that the high-voltage battery heats up sharply when the vehicle is stationary. E.g., with extreme external temperatures and direct solar radiation. Drive-ready state cannot be switched on if the high-voltage battery is overheated.

A Check Control message is displayed.

Another message will indicate when drive-ready state is available again.

While driving

If the high-voltage battery overheats during the trip, the performance is reduced step-by-step in order to cool down the battery. The ePOWER performance display in the instrument cluster decreases. If the temperature increases further, park the vehicle until the high-voltage battery has cooled down. If the performance display falls to 0, the drive-ready state is switched off and the vehicle comes to a stop.

- ▷ On uphill grades or on a downhill slope, turn the front wheels in the direction of the curb.
- ▷ On uphill grades or on a downhill slope, also secure the vehicle, for instance with a wheel chock.

WARNING

Unattended children or animals can cause the vehicle to move and endanger themselves and traffic, for instance due to the following actions:

- ▷ Pressing the Start/Stop button.
- ▷ Releasing the parking brake.
- ▷ Opening and closing the doors or windows.
- ▷ Engaging selector lever position N.
- ▷ Using vehicle equipment.

There is a risk of accidents or injuries. Do not leave children or animals unattended in the vehicle. Take the remote control with you when exiting and lock the vehicle.

Parking brake

Concept

The parking brake is used to prevent the vehicle from rolling when it is parked.

Safety information

WARNING

An unsecured vehicle can begin to move and possibly roll away. There is a risk of an accident. Before exiting, secure the vehicle against rolling.

In order to ensure that the vehicle is secured against rolling away, follow the following:

- ▷ Set the parking brake.

Overview



 Parking brake

Setting

With a stationary vehicle

 Pull the switch.
The LED lights up.



The indicator light lights up red. The parking brake is set.

While driving

To use as emergency brake while driving:

Pull the switch and hold it. The vehicle brakes hard while the switch is being pulled.



The indicator light lights up red, a signal sounds and the brake lights light up.

A Check Control message is displayed.

If the vehicle is slowed down to a speed of approx. 2 mph/3 km/h the parking brake is set.

Releasing

Releasing manually

1. Switch on drive-ready state.
2.  Press the switch while stepping on the brake pedal or selector lever position P is set.
 - The LED and indicator light go out.
 - The parking brake is released.

Automatic release

For automatic release, step on the accelerator pedal.

The LED and indicator light go out.

The parking brake is automatically released when you step on the accelerator pedal under the following conditions:

- ▶ Drive-ready state switched on.
- ▶ Drive mode engaged.
- ▶ Driver buckled in and doors closed.

Malfunction

In the event of a failure or malfunction of the parking brake, secure the vehicle against rolling using a wheel chock, for instance when leaving it.

After a power failure

Putting the parking brake into operation

1. Switch on standby state.
2.  Press the switch while stepping on the brake pedal or selector lever position P is set.

It may take several seconds for the brake to be put into operation. Any sounds associated with this are normal.



The indicator light in the instrument cluster goes out as soon as the parking brake is ready for operation.

Hold function

Concept

The system holds the vehicle automatically when gear is engaged. This prevents rolling against the direction of travel.

In selector lever position D, the vehicle cannot roll backwards. In selector lever position R, it cannot roll forward. The brake pedal does not have to be pressed.

Reducing energy consumption

To reduce energy consumption when the hold function is activated, activate the parking brake or engage the selector lever in position P when the vehicle is stopped for long periods of time.

The hold function can be affected by the vehicle's load and the road incline. If needed, a Check Control message will appear and position P will be selected automatically.

Turn signal, high beams, headlight flasher

Turn signal

Turn signal in exterior mirror

When driving and during operation of the turn signals or hazard warning system, do not fold in the exterior mirrors, so that the signal lights on the exterior mirror are easy to see.

Using turn signals

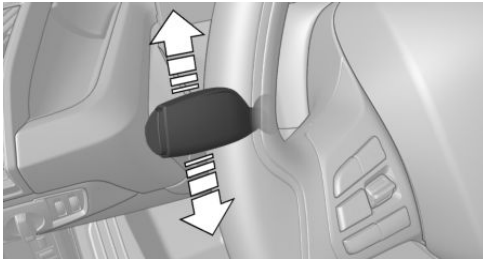

Press the lever past the resistance point.

The lever returns into its starting position after actuation. To switch off manually, slightly tap the lever to the resistance point.

Triple turn signal activation

Lightly tap the lever up or down.

The turn signal flashes three times.

The function can be activated or deactivated.

Via iDrive:

1. "My Vehicle"
2. "Vehicle settings"
3. "Lighting"
4. "Exterior lighting"
5. "One-touch turn signal"
6. Select the desired setting.

Settings are stored for the profile currently used.

Signaling briefly

Press the lever to the resistance point and hold it there for as long as you want the turn signal to flash.

Malfunction

Unusually rapid flashing of the indicator light indicates that a turn signal bulb has failed.

High beams, headlight flasher

Push the lever forward or pull it backward.

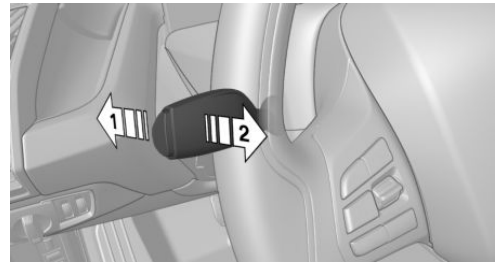

- ▶ High beams on, arrow 1.
- ▶ High beams off/headlight flasher, arrow 2.

Wiper system

General information

Do not use the wipers if the windshield is dry, as this may damage the wiper blades or cause them to become worn more quickly.

Safety information

WARNING

If the wipers start moving in the folded away state, body parts can be jammed or damage may occur to parts of the vehicle. There is a risk of injury or risk of damage to property. Make sure that the vehicle is switched off when the wipers are in the folded away state and the wipers are folded in when switching on.

**NOTE**

If the wipers are frozen to the windshield, the wiper blades can be torn off and the wiper motor can overheat when switching on. There is a risk of damage to property. Defrost the windshield prior to switching the wipers on.

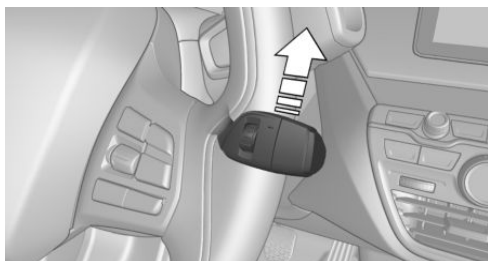
Switching on

Tap up the lever or press it past the resistance point.

- ▷ Normal wiper speed: tap up once.
- ▷ Fast wiper speed: tap up twice or tap once beyond the resistance point.

The lever automatically returns to its initial position when released.

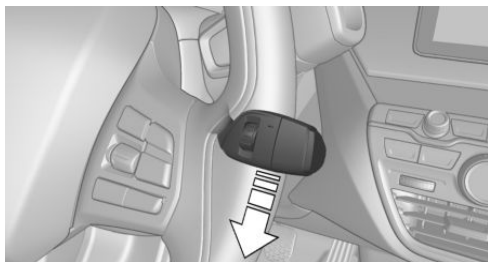
Switching off and brief wipe

Press the lever down.

- ▷ To switch off from fast wiper speed: press down twice.
- ▷ To switch off from normal wiper speed: press down once.
- ▷ Brief wipe: press down once.

The lever automatically returns to its initial position when released.

Interval mode or rain sensor**Concept**

The rain sensor automatically controls the time between wipes depending on the intensity of the rainfall.

General information

The sensor is located on the windshield, directly in front of the interior mirror. Without the rain sensor, the frequency of the wiper operation is preset.

Safety information**NOTE**

If the rain sensor is activated, the wipers can accidentally start moving in vehicle washes. There is a risk of damage to property. Deactivate the rain sensor in vehicle washes.

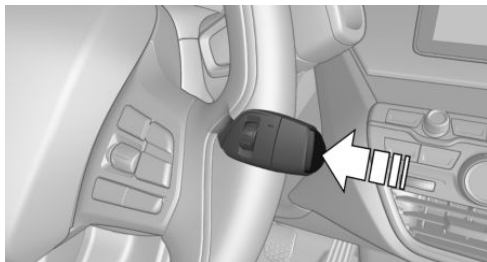
Activating/deactivating

Press the button on the wiper lever.

Wiping is started.

If the vehicle is equipped with a rain sensor: the LED in the wiper lever is illuminated.

If wipers are frozen to windshield, wiper operation is deactivated.

During trip interruption with the rain sensor switched on: if the trip is resumed within approx.

15 minutes, the rain sensor is automatically activated again.

Setting the frequency or sensitivity of the rain sensor

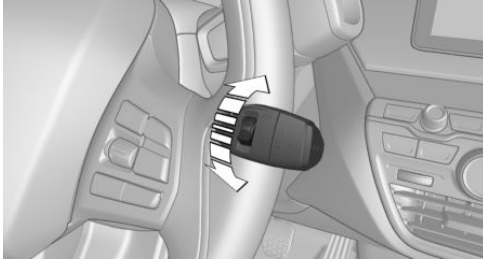

Turn the thumbwheel to adjust the frequency or sensitivity of the rain sensor.

Up: short interval or high sensitivity of the rain sensor.

Down: long interval or low sensitivity of the rain sensor.

Windshield washer system

Safety information

WARNING

The washer fluid can freeze onto the window at low temperatures and obstruct the view. There is a risk of an accident. Only use the washer systems, if the washer fluid cannot freeze. Use antifreeze, if needed.

NOTE

When the washer fluid reservoir is empty, the wash pump cannot work as intended. There is a risk of damage to property. Do not use the washer system when the washer fluid reservoir is empty.

Cleaning the windshield

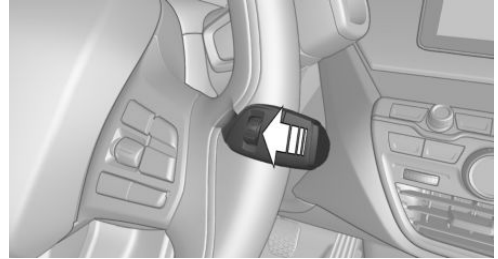

Pull the lever.

The system sprays washer fluid on the windshield and activates the wipers briefly.

Windshield washer nozzles

The windshield washer nozzles are automatically heated while standby state is switched on.

Rear window wiper

Overview

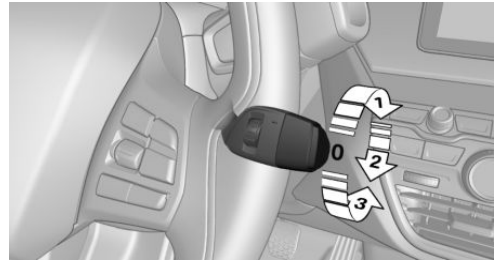

Switching on the rear window wiper

Turn the outer switch upward.

- ▷ Resting position of the wiper, position 0.
- ▷ Intermittent mode, arrow 1. When reverse gear is engaged, the system switches to continuous operation.

Clean the rear window

Turn the outer switch in the desired direction.



- ▶ In resting position: turn the switch downward, arrow 3. The switch automatically returns to its resting position when released.
- ▶ In intermittent mode: turn the switch further, arrow 2. The switch automatically returns to its intermittent position when released.

Fold-away position of the wipers

Concept

The fold-out position enables the wipers to be folded away from the windshield.

General information

Important, for instance when changing the wiper blades or when folding out under frosty conditions.

Safety information

WARNING

If the wipers start moving in the folded away state, body parts can be jammed or damage may occur to parts of the vehicle. There is a risk of injury or risk of damage to property. Make sure that the vehicle is switched off when the wipers are in the folded away state and the wipers are folded in when switching on.

NOTE

If the wipers are frozen to the windshield, the wiper blades can be torn off and the wiper motor can overheat when switching on. There is a risk of damage to property. Defrost the windshield prior to switching the wipers on.

Folding away the wipers

1. Switch standby state on and off again.
2. With frosty conditions, make sure that the blades are not frozen to the windshield.

3. Press the wiper lever up beyond the point of resistance and hold it for approx. 3 seconds, until the wipers remain in a nearly vertical position.
4. Fold the wipers all the way away from the windshield.

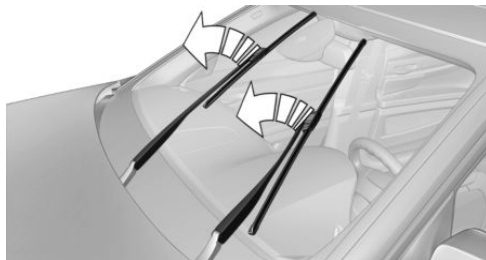

Folding down the wipers

After the wipers are folded back down, the wiper system must be reactivated.

1. Fold the wipers back down onto the windshield.
2. Switch on standby state.
3. Push wiper lever down. Wipers return to their resting position and are ready again for operation.

Washer fluid

General information

All washer nozzles are supplied from one reservoir.

Use a mixture of tap water and windshield washer concentrate. If desired, a windshield washer concentrate containing antifreeze can be used.

Recommended minimum fill quantity:
0.2 US gal/1 liter.

Safety information

WARNING

Some antifreeze agents can contain harmful substances and are flammable. There is a risk of fire and a risk of injury. Follow the instructions on the containers. Keep antifreeze away from ignition sources. Do not refill operating materials into different bottles. Store operating materials out of reach of children.

United States: the washer fluid mixture ratio is regulated by the U.S. EPA and many individual states; do not exceed the allowable washer fluid dilution ratio limits that apply. Follow the usage instructions on the washer fluid container.

Use of BMW's Windshield Washer Concentrate or the equivalent is recommended.

NOTE

Silicon-containing additives in the washer fluid for the water-repelling effect on the windows can lead to damage to the washing system. There is a risk of damage to property. Do not add silicon-containing additives to the washer fluid.

NOTE

Mixing different windshield washer concentrates or antifreeze can damage the washing system. There is a risk of damage to property. Do not mix different windshield washer concentrates or antifreeze. Follow the information and mixing ratios provided on the containers.

Overview

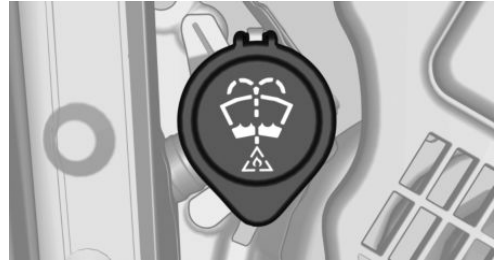

The washer fluid reservoir is located under the hood.

Malfunction

The use of undiluted windshield washer concentrate or alcohol-based antifreeze can lead to incorrect readings at temperatures below +5 °F/-15 °C.

Displays

Vehicle features and options

This chapter describes all standard, country-specific and optional features offered with the series. It also describes features that are not necessarily

available in your vehicle, e. g., due to the selected options or country versions. This also applies to safety-related functions and systems. When using these functions and systems, the applicable laws and regulations must be observed.

Instrument cluster

Concept

The instrument cluster is a variable display. Some of the displays in the instrument cluster

may differ from the way they are shown in this Owner's Manual.

Overview

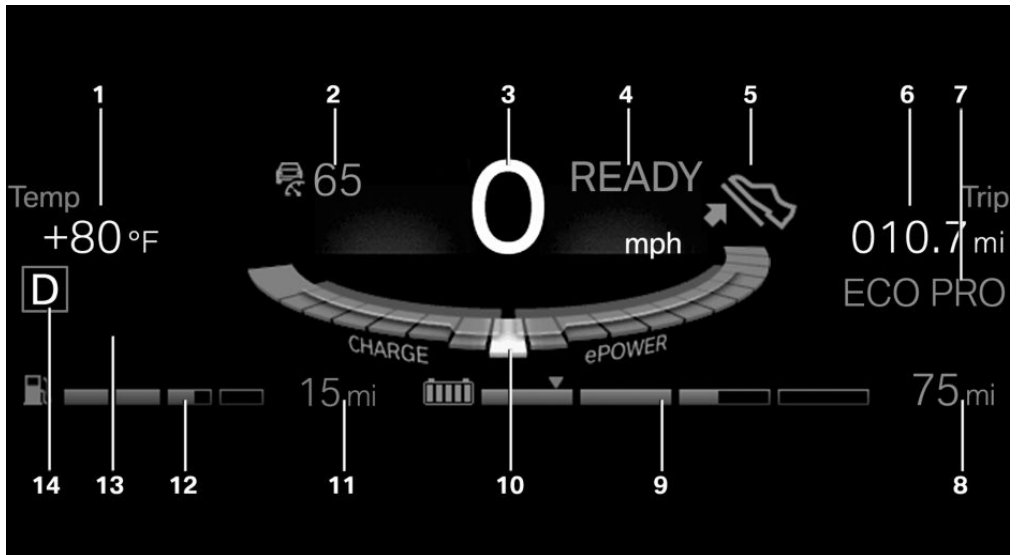

- | | | | |
|-------------------------------|-----|---------------------------------------|-----|
| 1 Onboard Computer | 126 | 7 Driving Dynamics Control program | 150 |
| 2 Driver assistance systems | | 8 Range for electric driving | 122 |
| 3 Speedometer | | 9 Battery charge indicator | 116 |
| 4 Drive-ready state indicator | 101 | 10 Performance display | 116 |
| 5 ECO PRO tips | 205 | Selection list, such as for the radio | 125 |
| 6 Trip odometer | 122 | 11 Range Extender range | 122 |

12 Range Extender fuel gauge [121](#)**14** Display, drive mode [102](#)**13** Messages, for instance Check Control

Charging screen

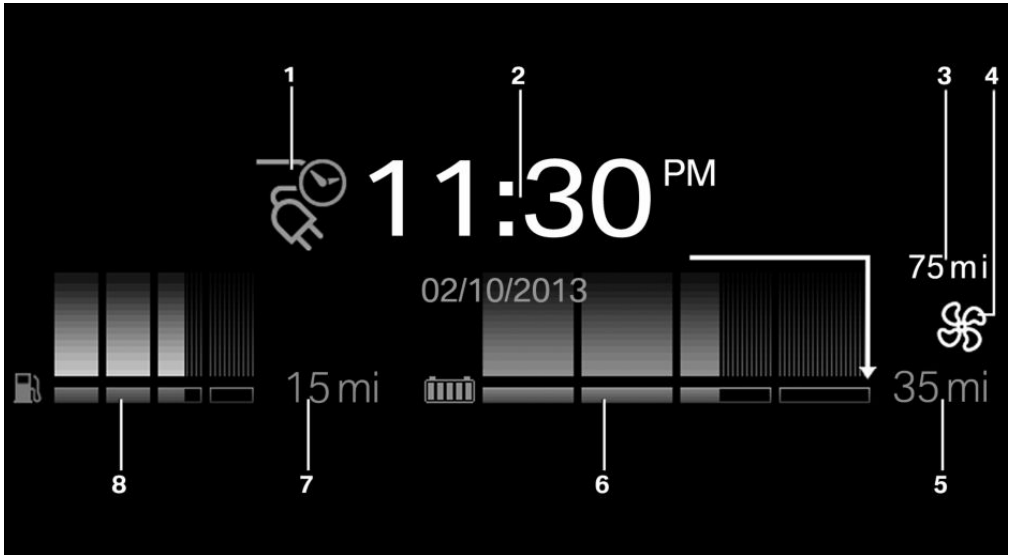
**1** Charging status [218](#)**5** Range for electric driving [218](#)**2** End of charging time [218](#)**6** Charge state [116](#)Departure time with timer [219](#)**7** Range Extender range [122](#)**3** Maximum electrical range [218](#)**8** With Range Extender: fuel gauge [121](#)**4** Stationary climate control [219](#)

Displaying the eDRIVE system

▷ Energy recovery: CHARGE.

▷ Drive-ready state: READY.

Displays in the instrument cluster

Concept

The display depends on the system's operating condition. The following functions of the eDRIVE system are shown in the instrument cluster

- ▷ High-voltage battery charge indicator.
- ▷ Electric driving: ePOWER.



High-voltage battery charge indicator

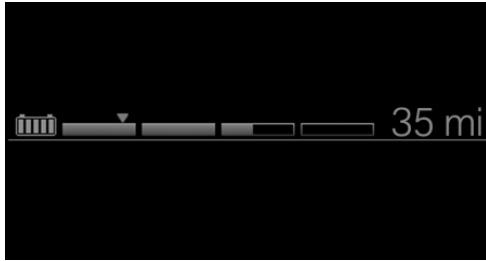

WARNING

Even when it is indicated that the high-voltage battery is discharged, the high-voltage system is always still under high voltage. There is a risk of fire or a risk of injury. Do not touch or change live parts, for instance orange high-voltage cables, even when the batteries are discharged.

The fill level bars indicate the available charge state of the high-voltage battery when standby state and drive-ready state are switched on.

With a low range the color of the charge state indicator switches from blue to yellow.

In addition, the range for electric driving is displayed.

With Range Extender: maintaining charge state

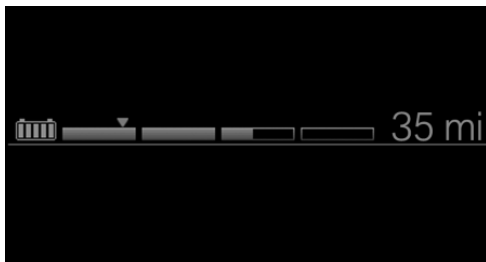

 The arrow on the charge state indicator designates the Range Extender activation time. If Range Extender is activated, the current charge state of the high-voltage battery is maintained.

- ▶ Gray arrow: Range Extender deactivated.
- ▶ White arrow: Range Extender activated.

Performance display



The accelerator pedal indicator in the performance display indicates the current efficiency of your driving style. The efficient range of the performance display is colored blue.

Accelerator pedal indicator in the CHARGE range, arrow 1: display for energy recovered by coasting or when decelerating.

Accelerator pedal indicator in the ePOWER range, arrow 2: display when accelerating.

The blue ePOWER range in the display is reduced if the high-voltage battery is heavily discharged. The available power is automatically adjusted.

Optimizing the driving style, refer to page 198.

Drive-ready state: READY



The READY display indicates that the vehicle is ready for driving. Drive-ready state in detail, refer to page 101.

Indications on the Control Display

Fuel consumption history

Displaying fuel consumption history

Via iDrive:

1. "My Vehicle"
2. "Technology in action"
3. "eDRIVE"
4.  Select the symbol.

Display

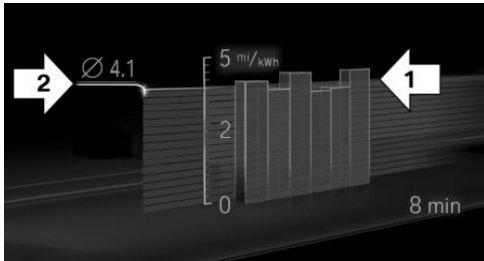

Bars show the average consumption over a specific period of time, arrow 1.

One bar indicates one minute.

The average fuel consumption of the eDRIVE system is indicated using a line and a value above the bar display, arrow 2. The indicated value is identical to the average fuel consumption in the Onboard Computer and can be reset via the Onboard Computer.

Energy flow of the eDRIVE system

Displaying the energy flow

Via iDrive:

1. "My Vehicle"
2. "Technology in action"
3. "eDRIVE"
4.  Select the symbol.

Display

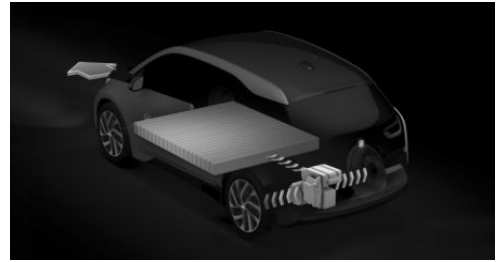

The display shows the active components of the eDRIVE system:

- ▷ Blue: electrical energy.
- ▷ Arrow: direction of the energy flow.
- ▷ Segments of the high-voltage battery symbolize the charging state.
- ▷ The operating states, such as eDRIVE, are displayed.
- ▷ Interior cooling/heating function switched on.

Energy distribution

General information

Beside the current range, the display shows the energy distribution and the potential range if individual secondary functions are switched off.

- ▷ Blue: electrical energy.
- ▷ White: activated secondary functions.

Displaying energy distribution

Via iDrive:

1. "My Vehicle"
2. "Technology in action"
3. "Comfort information"



Check Control

Concept

The Check Control system monitors functions in the vehicle and notifies you of malfunctions in the monitored systems.

General information

A Check Control message is displayed as a combination of indicator or warning lights and SMS text messages in the instrument cluster.

In addition, an acoustic signal may sound and an SMS text message may appear on the Control Display.

Indicator/warning lights

General information

The indicator/warning lights in the instrument cluster can light up in a variety of combinations and colors.

Several lights indicate function checks and light up only temporarily when drive-ready state or standby state are activated.

Red lights

Safety belt reminder



Safety belt on the driver's side is not buckled. For some country versions: passenger belt is not worn or objects are detected on the front passenger seat.

Indicator light flashes or is illuminated: safety belt on the driver or passenger side is not buckled.

The safety belt reminder can also be activated if objects are placed on the front passenger seat.

Make sure that the safety belts are positioned correctly.

Airbag system



Airbag system and belt tensioner are not working.

Have the vehicle checked immediately by a dealer's service center or another qualified service center or repair shop.

Parking brake



The parking brake is set.

Release the parking brake, refer to page 108.

Brake system



Braking system impaired. Continue to drive moderately.

Have the vehicle checked immediately by a dealer's service center or another qualified service center or repair shop.

Approach control warning



Indicator light illuminates: advance warning is issued, for example when there is the impending danger of a collision or the distance to the vehicle ahead is too small.

Increase distance.

Indicator light flashes: acute warning of the imminent danger of a collision when the vehicle approaches another vehicle at a relatively high differential speed.

Intervention by braking or make an evasive maneuver.

Person warning



If a collision with a person detected in this way is imminent, the symbol lights up and a signal sounds.



Orange lights

Active Cruise Control



The number bars shows the selected distance from the vehicle driving ahead.

Active Cruise Control with Stop&Go function, ACC, refer to page [153](#).

Vehicle detection, Active Cruise Control



Indicator light illuminates: a vehicle has been detected ahead of you.

Indicator light flashes: the conditions are not adequate for the system to work.

The system was deactivated but applies the brakes until you actively resume control by pressing on the brake pedal or accelerator pedal.

Yellow lights

Anti-lock Braking System ABS



Braking force boost may not be working. Avoid abrupt braking. Take the longer braking distance into account.

ABS Have the system immediately checked by a dealer's service center or another qualified service center or repair shop.

DSC Dynamic Stability Control



The indicator light flashes: DSC controls the drive and braking forces. The vehicle is stabilized. Reduce speed and modify your driving style to the driving circumstances. The indicator light lights up: DSC has malfunctioned.

Have the system checked by a dealer's service center or another qualified service center or repair shop.

DSC, refer to page [149](#).

DSC Dynamic Stability Control is deactivated or DTC Dynamic Traction Control is activated



DSC is deactivated or DTC is activated. DSC, refer to page [149](#), and DTC, refer to page [150](#).

Flat Tire Monitor FTM



The Flat Tire Monitor signals a loss of tire inflation pressure in a tire.

Reduce your speed and stop cautiously. Avoid sudden braking and steering maneuvers. Flat Tire Monitor, refer to page [139](#).

Tire Pressure Monitor TPM



The indicator light lights up: the Tire Pressure Monitor reports a low tire inflation pressure or a flat tire. Follow the information in the Check Control message.

The indicator light flashes and then continuously lights up: no flat tire or loss of tire inflation pressure can be detected.

- ▶ Interference caused by systems or devices with the same radio frequency: after leaving the area of the interference, the system automatically becomes active again.
- ▶ TPM was unable to complete the reset. Reset the system again.
- ▶ A wheel without TPM wheel electronics is mounted: have it checked by a dealer's service center or another qualified service center or repair shop as needed.
- ▶ Malfunction: have the system checked by a dealer's service center or another qualified service center or repair shop.

Tire Pressure Monitor, refer to page [136](#).

Steering system



Steering system in some cases not working.



Have the system checked by a dealer's service center or another qualified service center or repair shop.

Emissions



▶ The warning light lights up:
Emissions are deteriorating. Have the vehicle checked as soon as possible.

- ▶ The warning light flashes under certain circumstances:
This indicates that there is excessive misfiring in the engine.
Reduce the vehicle speed and have the system checked immediately; otherwise, serious engine misfiring within a brief period can seriously damage emission control components, in particular the catalytic converter.

Socket for Onboard Diagnosis, refer to page 250.

Acoustic pedestrian protection inactive



Acoustic pedestrian protection deactivated or possibly not working.

Have the system checked by a dealer's service center or another qualified service center or repair shop.

Green lights

Turn signal



Turn signal switched on.

Unusually rapid flashing of the indicator light indicates that a turn signal bulb has failed.

Turn signal, refer to page 109.

Parking lights, headlight



Parking lights or headlights are switched on.

Parking lights/low beams, headlight control, refer to page 129.

Cruise control



The system is switched on. It maintains the speed that was set using the control elements on the steering wheel.

Blue lights

High beams



High beams are switched on.
High beams, refer to page 109.

Hiding Check Control messages

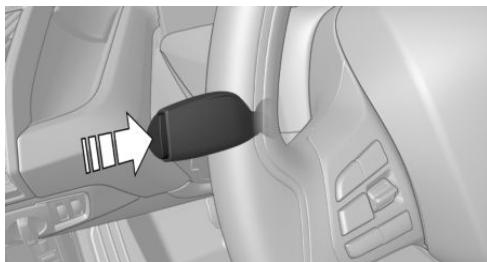

Press and hold button on signal lever.

Continuous display

Some Check Control messages are displayed continuously and are not cleared until the malfunction is eliminated. If several malfunctions occur at once, the messages are displayed consecutively.

The messages can be hidden for approx. 8 seconds. After this time, they are displayed again automatically.

Temporary display

Some Check Control messages are hidden automatically after approx. 20 seconds. The Check Control messages are stored and can be displayed again later.



Displaying stored Check Control messages

Via iDrive:

1. "My Vehicle"
2. "Vehicle status"
3.  "Check Control"
4. Select the SMS text message.

Display

Check Control



At least one Check Control message is displayed or is stored.

SMS text messages

SMS text messages in combination with a symbol in the instrument cluster explain a Check Control message and the meaning of the indicator/warning lights.

Supplementary SMS text messages

Additional information, such as on the cause of an error or the required action, can be called up via Check Control.

With urgent messages the added text will be automatically displayed on the Control Display.

Functions

Depending on the Check Control message, the following functions can be selected.

- ▶ "Owner's Manual"
Display additional information about the Check Control message in the Integrated Owner's Manual.
- ▶ "Service request"
Contact a dealer's service center or another qualified service center or repair shop.
- ▶ "BMW i Roadside Assistance"
Contact Roadside Assistance.

Messages after trip completion

Special messages displayed while driving are displayed again after standby state is switched off.

With Range Extender: fuel gauge



The fill level bars indicate the available fuel supply of the Range Extender when drive-ready state and standby state are switched on.

Additional range of the Range Extender on top of pure electric range. If the Range Extender is activated, the color of the fill level bar indicator switches from gray to white.

Vehicle tilt position may cause the display to vary.

Follow the information on refueling.

Coolant temperature

If the coolant along with the engine becomes too hot, a Check Control message is displayed.



A red indicator light is displayed.

Check the coolant level, refer to page [247](#).

Odometer and trip odometer

Display

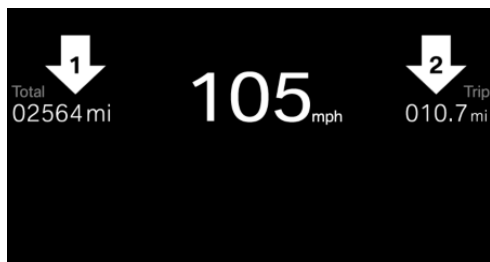

- ▶ Odometer, arrow 1, Scope of the Onboard Computer.
- ▶ Trip odometer, arrow 2.

Show/reset miles: TRIP

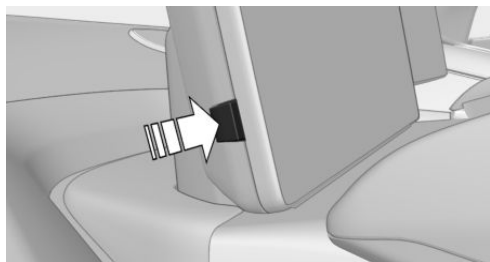

Press the button.

- ▶ With standby state switched off, the time, the external temperature and the odometer are displayed.
- ▶ When standby state is switched on, the trip odometer is reset.

External temperature

General information

If the indicator drops to +37 °F/+3 °C or lower, a signal sounds.

A Check Control message is displayed.

There is an increased risk of ice on roads.

Safety information

! WARNING

Even at temperatures above +37 °F/+3 °C there can be a risk of icy roads, for instance on bridges or shady sections of road. There is a risk of an accident. Modify your driving style to the weather conditions at low temperatures.

Time

The time is displayed in the Onboard Computer. The time can be set on the Control Display.

Range

General information

The expected range for the energy stored in the high-voltage battery is displayed on the right side of the instrument cluster next to the charge state indicator of the high-voltage battery.

Always make sure that the range is sufficient for the planned trip. The range is dynamic and can abruptly change.

The range can be abruptly reduced or increased based on the following factors:

- ▶ Driving style.
- ▶ Traffic conditions.
- ▶ Program change via Driving Dynamics Control.
- ▶ Climate and terrain conditions.
- ▶ Automatic climate control settings.
- ▶ After determination of a route by the navigation system.
- ▶ When exiting a route or recalculating a route.

For more information on increasing the range, see Using eDRIVE efficiently.

Check Control messages indicate a limited range.



Heavily discharged high-voltage battery



The high-voltage battery is heavily discharged. Its power output will be reduced. Heating and climate control functions will be deactivated. In this state, the exact range can no longer be calculated. A short range may still be available depending on the environmental conditions.

State of charge in strong temperature fluctuations

In the case of strong temperature fluctuations and a low state of charge of the high-voltage battery, it may not be possible to start the vehicle again at the beginning of the next trip. Recharge vehicle with low state of charge in time.

With Range Extender

The range of the Range Extender is displayed separately next to the fuel gauge. The total range can be displayed via the Onboard Computer. Expanding the range with Range Extender, refer to page 106.

Service requirements

Concept

The function displays the service requirements and the corresponding maintenance scopes.

General information

The driving distance or the time to the next scheduled maintenance is displayed briefly in the instrument cluster after standby state is switched on.

A service advisor can read out the current service requirements from your remote control.

Display



Detailed information on service requirements

More information on the type of service required may be displayed on the Control Display.

Via iDrive:

1. "My Vehicle"
2. "Vehicle status"
3.  "Service required"
Required maintenance procedures and legally mandated inspections are displayed.
4. Select an entry to call up detailed information.

Symbols

Symbols	Description
	No service is currently required.
	The deadline for scheduled maintenance or a legally mandated inspection is approaching.
	The service deadline has already passed.

Entering appointment dates

Enter the dates for the mandatory vehicle inspections.

Make sure that the vehicle's date and time are set correctly.

Via iDrive:

1. "My Vehicle"
2. "Vehicle status"
3.  "Service required"
4. "Vehicle inspection"
5. "Date:"
6. Select the desired setting.



Automatic Service Request

Data regarding the service status or legally mandated vehicle inspections is automatically transmitted to your dealer's service center before your vehicle is due for service.

You can check when your dealer's service center was notified.

Via iDrive:

1. "My Vehicle"
2. "Vehicle status"
3.  "Teleservice Call"

Speed Limit Info

Speed Limit Info

Concept

Speed Limit Info shows the current maximum permitted speed in the instrument cluster.

General information

The camera in the area of the interior mirror detects traffic signs at the edge of the road as well as variable overhead sign posts. Traffic signs with extra symbols for wet road conditions, etc., are also detected and compared with the vehicle's onboard data, such as from the rain sensor, and will be displayed depending on the situation. The system takes into account the information stored in the navigation system and also displays speed limits present on routes without signs.

Safety information

WARNING

The system cannot serve as a substitute for the driver's personal judgment in assessing visibility and traffic situation. There is a risk of an accident. Adjust driving style to traffic conditions.

Watch traffic closely and actively intervene where appropriate.

Overview

Camera

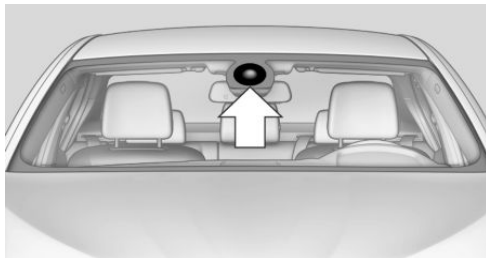

The camera is installed near the interior mirror. Keep the windshield in front of the interior mirror clean and clear.

Switching on/off

Via iDrive:

1. "My Vehicle"
2. "iDrive settings"
3. "Displays"
4. "Instrument panel"
5. "Speed limit information"

If Speed Limit Info is switched on, it can be displayed on the Info Display in the instrument cluster.

Display

Speed Limit Info

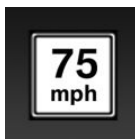

Current speed limit.



Speed Limit Info not available.

System limits

The system may not be fully functional and may provide incorrect information in the following situations:

- ▶ In heavy fog, wet conditions, or snowfall.
- ▶ When signs are fully or partially concealed by objects, stickers or paint.
- ▶ When driving very close to the vehicle in front of you.
- ▶ When driving toward bright lights or strong reflections.
- ▶ When the windshield in front of the interior mirror is fogged over, dirty or covered by a sticker, etc.
- ▶ In the event of incorrect detection by the camera.
- ▶ If the speed limits stored in the navigation system are incorrect.
- ▶ In areas not covered by the navigation system.
- ▶ When roads differ from the navigation, such as due to changes in road routing.
- ▶ When passing buses or trucks with a speed sticker.
- ▶ If the traffic signs are non-conforming.
- ▶ During calibration of the camera immediately after vehicle delivery.
- ▶ When signs that are valid for a parallel road are detected.

Selection lists

General information

Depending on your vehicle's equipment, the following can be displayed or operated using the

buttons and the thumbwheel on the steering wheel and the display in the instrument cluster:

- ▶ Current audio source.
- ▶ Redial phone feature.
- ▶ Turn on voice activation system.

It also displays programs of the Driving Dynamics Control.

Activating a list and adjusting the setting

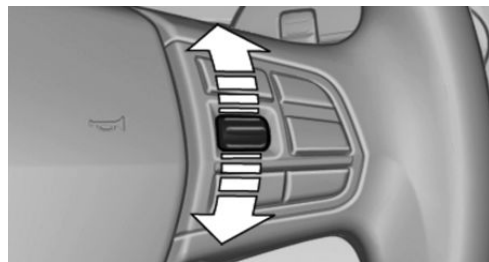

On the right side of the steering wheel, turn the thumbwheel to activate the corresponding list.

1. Turn the thumbwheel and select the desired setting.
2. Press the thumbwheel.

Display

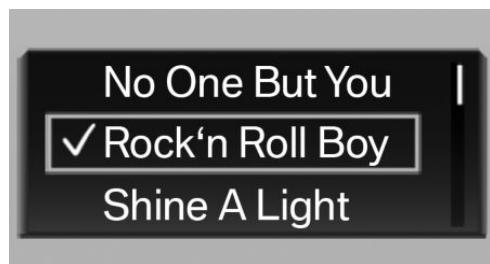

Depending on the equipment version, the list in the instrument cluster may differ from the illustration.



Onboard Computer

Concept

The Onboard Computer displays different vehicle data in the instrument cluster, such as average values.

Calling up information on the Info Display

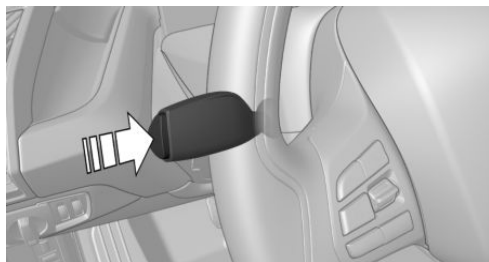

Press and hold button on signal lever.

Information is displayed in the Info Display of the instrument cluster. Pressing the button repeatedly displays additional information.

Information at a glance

Repeatedly pressing the button on the turn signal lever calls up the following information in the Info Display:

- ▷ Miles.
- ▷ With Range Extender: total range.
- ▷ Average fuel consumption.
- ▷ Current fuel consumption.
- ▷ Average speed.
- ▷ External temperature.
- ▷ Time.
- ▷ Speed Limit Info.
- ▷ Charge state of the high-voltage battery as a percentage.

Selecting information

You can select what information from the Onboard Computer is to be displayed on the Info Display of the instrument cluster.

Via iDrive:

1. "My Vehicle"
2. "iDrive settings"
3. "Displays"
4. "Instrument panel"
5. Select the desired setting.

Display in the instrument cluster

The information from the Onboard Computer is shown in the upper left area of the instrument cluster.

Information in detail

With Range Extender: total range

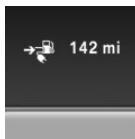

The total range considers the capacity of the fuel tank as well as the electric energy in the high-voltage battery.

Average fuel consumption

The average fuel consumption is calculated on the basis of various distances. Standstill with drive-ready state switched off is not considered.

Current fuel consumption

Displays the current energy consumption. The efficiency of the driving can be monitored.

Average speed

Periods when vehicle is parked with drive-ready state switched off are not included when calculating average speed.

Resetting average values

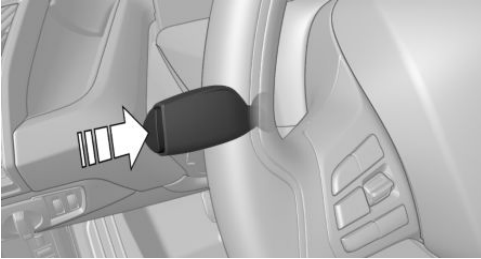

Press and hold button on turn signal lever.

Speed Limit Info

Speed Limit Info shows the current maximum permitted speed in the instrument cluster.

Display of charge state of the high-voltage battery as a percentage

The current charge state of the high-voltage battery can be displayed as a %-value.

Onboard Computer on the Control Display

Concept

The Onboard Computer displays different vehicle data on the Control Display, such as average values.

General information

Two types of Onboard Computers are available on the Control Display:

- ▶ "Onboard info": average values, such as the fuel consumption, are displayed. The values can be reset individually.
- ▶ "Trip computer": the values deliver an overview of a certain distance and can be reset as often as necessary.

Calling up the Onboard Computer or trip computer

Via iDrive:

1. "My Vehicle"
2. "Driving information"
3. "Onboard info" or "Trip computer"



Resetting the Onboard Computer

Via iDrive:

1. "My Vehicle"
2. "Driving information"
3. "Onboard info"
4. "Consumption" or "Speed"
5. "OK"

Resetting the trip computer

Via iDrive:

1. "My Vehicle"
2. "Driving information"
3. "Trip computer"
4. Move the Controller to the left, if needed.
 - ▶  "Reset": all values are reset.
 - ▶  "Automatic reset": all values are reset approx. 4 hours after the vehicle has come to a standstill.
5. If necessary, "OK"

Speed warning

Concept

A speed limit can be set that when reached will cause a warning to be issued.

General information

The warning is repeated if the vehicle speed exceeds the set speed limit again, after it has dropped below it by 3 mph/5 km/h.



Displaying, setting or changing the speed warning

Via iDrive:

1. "My Vehicle"
2. "Vehicle settings"
3. "Speed warning"
4. "Warning at:"
5. Turn the Controller until the desired speed is displayed.
6. Press the Controller.

Activating/deactivating the speed warning

Via iDrive:

1. "My Vehicle"
2. "Vehicle settings"
3. "Speed warning"
4. "Speed warning"

Setting your current speed as the speed warning

Via iDrive:

1. "My Vehicle"
2. "Vehicle settings"
3. "Speed warning"
4. "Select current speed"

Vehicle status

General information





The status can be displayed and actions performed for several systems.

Opening the vehicle status

Via iDrive:

1. "My Vehicle"
2. "Vehicle status"

Information at a glance

- ▶  "Flat Tire Monitor": status of the Flat Tire Monitor, refer to page [139](#).
- ▶  "Tire Pressure Monitor": status of the Tire Pressure Monitor, refer to page [136](#).
- ▶  "Check Control": Check Control messages are stored in the background and can be displayed on the Control Display. Displaying stored Check Control messages, refer to page [121](#).
- ▶  "Service required": Displaying service requirements, refer to page [123](#).
- ▶  "Teleservice Call": service request.

Lights

Vehicle features and options



This chapter describes all standard, country-specific and optional features offered with the series. It also describes features that are not necessarily available in your vehicle, e. g., due to the selected options or country versions. This also applies to safety-related functions and systems. When using these functions and systems, the applicable laws and regulations must be observed.

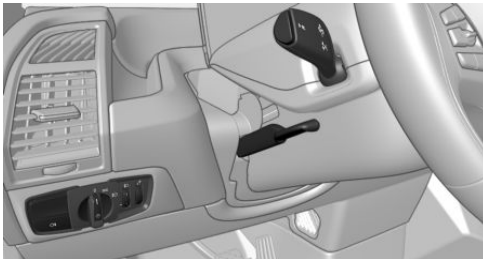

Overview

Switches in the vehicle



The light switch element is located next to the steering wheel.

Symbol	Function
	Automatic headlight control.
	Lights off. Daytime running lights.
	Parking lights.

Symbol	Function
	Low beams.
	Instrument lighting.

Parking lights, low beams and roadside parking lights

General information

Position of switch:  ,  , 

If the driver's door is opened when standby state is switched off, the exterior lighting is automatically switched off.

Parking lights

Position of switch: 

The vehicle is illuminated on all sides.

Do not use the parking lights for extended periods; otherwise, they might drain the battery and it would then be impossible to switch on drive-ready state.

When parking, switch on the one-sided roadside parking light, refer to page 129.

Low beams

Position of switch: 

The low beams illuminate when standby state is switched on.

Roadside parking light

Concept

The vehicle can be illuminated on one side.



Switching on

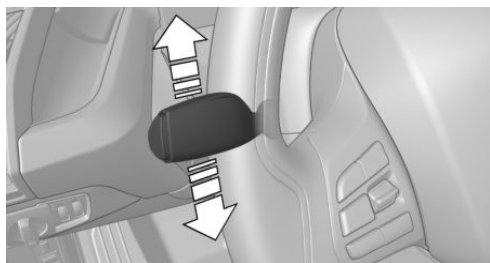

With standby state switched off, press the lever either up or down past the resistance point for approx. 2 seconds.

Switching off

Briefly press the lever to the resistance point in the opposite direction.

Welcome lights and headlight courtesy delay feature

Welcome lights

General information

Depending on the vehicle equipment and the ambient brightness, individual light functions may be switched on briefly when the vehicle is unlocked.

Activating/deactivating

Position of switch:  D , 

Via iDrive:

1. "My Vehicle"
2. "Vehicle settings"
3. "Lighting"
4. "Exterior lighting"
5. "Welcome lights"

The setting is stored for the driver profile currently used.

Headlight courtesy delay feature

General information

The low beams stay lit for a short while if the headlight flasher is switched on after the radio-ready state is switched off.

Setting the duration

Via iDrive:

1. "My Vehicle"
2. "Vehicle settings"
3. "Lighting"
4. "Exterior lighting"
5. "Pathway lighting"
6. Set length of time.

The setting is stored for the driver profile currently used.

Automatic headlight control

Concept

The low beams are switched on and off automatically depending on the ambient brightness, for instance in tunnels, in twilight or if there is precipitation.

General information

A blue sky with the sun low on the horizon can cause the lights to be switched on.

Activating

Position of switch: 

The indicator light in the instrument cluster is illuminated when the low beams are switched on.

System limits

The automatic headlight control cannot serve as a substitute for your personal judgment of lighting conditions.



For example, the sensors are unable to detect fog or hazy weather. To avoid safety risks under these conditions, you should always switch on the lights manually.

Daytime running lights

General information

Position of switch:  ,  , 

The daytime running lights light up when standby state is switched on. After standby state is switched off, the parking lights light up in position  .

Activating/deactivating

In some countries, daytime running lights are mandatory, so it may not be possible to deactivate the daytime running lights.

Via iDrive:

1. "My Vehicle"
2. "Vehicle settings"
3. "Lighting"
4. "Exterior lighting"
5. Select the desired setting.

Settings are stored for the profile currently used.

Adaptive headlight range control

The adaptive headlight range control compensates for acceleration and braking operations in order not to blind the oncoming traffic and to achieve optimum illumination of the roadway.

Instrument lighting

Functional requirement

The parking lights or low beams must be switched on to adjust the brightness.

Settings



Adjust the brightness with the thumbwheel.

Interior lights

General information

Depending on the equipment, the interior lights, footwell lights, entry lights, and courtesy lights are controlled automatically.

Thumbwheel for the instrument lighting controls brightness of some of these features.

Overview



- 1 Interior lights
- 2 Reading lights

Switching the interior lights on/off



Press button.

To switch off permanently: press the button and hold for approx. 3 seconds.

Switching the reading lights on/off



Press button.

Reading lights are located in the front next to the interior light.



Ambient light

General information

Depending on the equipment version, lighting can be adjusted for some lights in the car's interior.

Selecting color scheme

Via iDrive:

1. "My Vehicle"
2. "Vehicle settings"
3. "Lighting"
4. "Interior lighting"
5. "Ambient lighting"
6. Select the desired setting.

To deactivate the ambient light: "Off".

With a color scheme selected and welcome lights activated they illuminate in blue when vehicle is unlocked.

Setting the brightness

Depending on the equipment, the brightness of the ambient light can be adjusted via the thumb-wheel for the instrument lighting or on the Control Display.

Via iDrive:

1. "My Vehicle"
2. "Vehicle settings"
3. "Lighting"
4. "Interior lighting"
5. "Brightness"
6. Adjust the brightness.

Safety

Vehicle features and options

This chapter describes all standard, country-specific and optional features offered with the series. It also describes features that are not necessarily

available in your vehicle, e. g., due to the selected options or country versions. This also applies to safety-related functions and systems. When using these functions and systems, the applicable laws and regulations must be observed.

Airbags

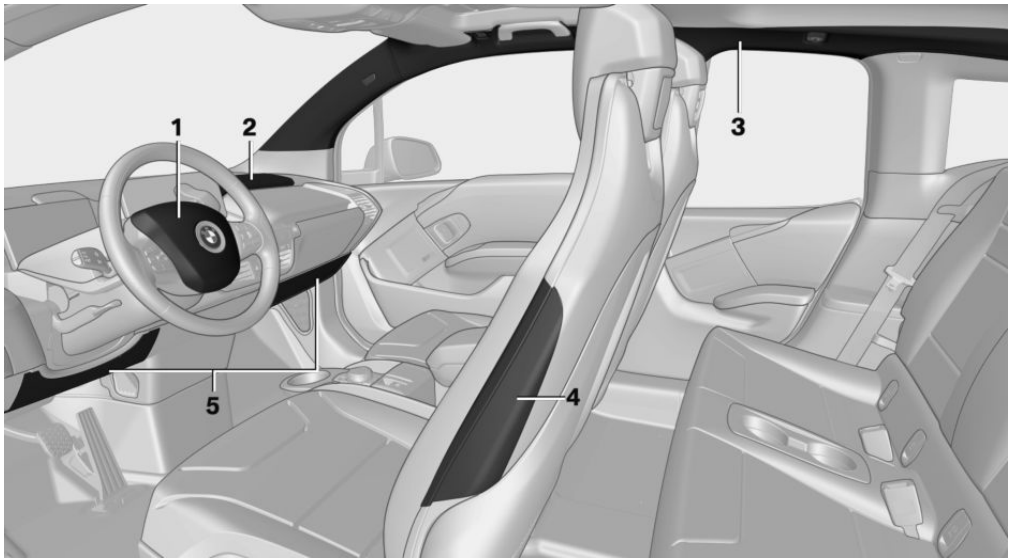

- | | |
|---|--|
| <ul style="list-style-type: none"> 1 Front airbag, driver 2 Front airbag, front passenger 3 Head airbag | <ul style="list-style-type: none"> 4 Side airbag 5 Knee airbag |
|---|--|

Front airbags

Front airbags help protect the driver and the front passenger by responding to frontal impacts in which safety belts alone would not provide adequate protection.

Side airbag

In a lateral impact, the side airbag supports the side of the body in the chest and lap area.

Head airbag

In a lateral impact, the head airbag supports the head.



Ejection Mitigation

The head airbag system is designed as an ejection mitigation countermeasure to reduce the likelihood of ejections of vehicle occupants through side windows during rollovers or side impact events.

Knee airbag

The knee airbag supports the legs in a frontal impact.

Protective action

Airbags are not triggered in every impact situation, for instance in less severe accidents or rear-end collisions.

Information on optimum effect of the airbags

WARNING

If the seat position is incorrect or the deployment area of the airbags is impaired, the airbag system cannot provide protection as intended and may cause additional injuries due to triggering. There is a risk of injuries or danger to life. Follow the information on achieving the optimum protective effect of the airbag system.

- ▷ Keep a distance from the airbags.
- ▷ Always grasp the steering wheel on the steering wheel rim. Hold your hands at the 3 o'clock and 9 o'clock positions, to keep the risk of injury to your hands or arms as low as possible when the airbag is triggered.
- ▷ Make sure that occupants keep their heads away from the side airbag.
- ▷ Make sure that the front passenger is sitting correctly, i.e., keeps his or her feet and legs in the floor area and does not support them on the dashboard.
- ▷ There should be no additional persons, animals or objects between an airbag and a person.

- ▷ Dashboard and windshield on the front passenger side must stay clear - do not attach adhesive labels or coverings and do not attach brackets or cables, for instance for GPS devices or mobile phones.
- ▷ Do not apply adhesive materials to the airbag cover panels, do not cover them or modify them in any way.
- ▷ Do not use the cover of the front airbag on the front passenger side as a storage area.
- ▷ Do not place slip covers, seat cushions or other objects on the front passenger seat that are not specifically suited for seats with integrated side airbags.
- ▷ Do not hang pieces of clothing, such as jackets, over the backrests.
- ▷ Never modify either the individual components or the wiring in the airbag system. This also applies to steering wheel covers, the dashboard, and the seats.
- ▷ Do not remove the airbag system.

Even when you follow all instructions very closely, injury from contact with the airbags cannot be fully ruled out in certain situations.

The ignition and inflation noise may lead to short-term and, in most cases, temporary hearing impairment in sensitive occupants.

Vehicle modifications for a person with disabilities may affect the air bag system; contact BMW Customer Relations for further information.

Warnings and information on the airbags are also found on the sun visors.

Functional readiness of the airbag system

Safety information

WARNING

Individual components can be hot after triggering of the airbag system. There is a risk of injury. Do not touch individual components.

**⚠ WARNING**

Improperly executed work can lead to failure, malfunction or unintentional triggering of the airbag system. In the case of a malfunction, the airbag system might not trigger as intended despite the accident severity. There is a risk of injuries or danger to life. Have the airbag system checked, repaired, dismantled and scrapped by a dealer's service center or another qualified service center or repair shop.

Correct function

With the standby state switched on, the warning light in the instrument cluster lights up briefly, indicating the airbag system and belt tensioner are functional.

Airbag system malfunctioning

- ▶ Warning light does not come on when standby state is switched on.
- ▶ The warning light lights up continuously.

Automatic deactivation of the front-seat passenger airbags**Concept**

The system reads if the front passenger seat is occupied by measuring the human body's resistance.

Front, knee, and side airbag on the front passenger's side are activated or deactivated.

General information

Before transporting a child on the front passenger seat, refer to the safety information and instructions for children on the front passenger seat, see Children.

Safety information**⚠ WARNING**

To ensure the front-seat passenger airbag function, the system must be able to detect whether a person is sitting in the front passenger seat. The entire seat cushion area must be used for this purpose. There is a risk of injuries or danger to life. Make sure that the front passenger keeps his or her feet in the floor area.

Malfunction of the automatic deactivation system

When transporting older children and adults, the front-seat passenger airbags may be deactivated in certain sitting positions. In this case, the indicator light for the front-seat passenger airbags lights up.

In this case, change the sitting position so that the front-seat passenger airbags are activated and the indicator light goes out.

If it is not possible to activate the airbags, have the person sit in the rear.

To enable correct recognition of the occupied seat cushion.

- ▶ Do not attach covers, cushions, ball mats or other items to the front passenger seat unless they are specifically determined to be safe for use on the front passenger seat.
- ▶ Do not place any electronic devices on the front passenger seat if a child restraint system is to be installed on it.
- ▶ Do not place objects under the seat that could press against the seat from below.
- ▶ No moisture in or on the seat.



Indicator light for the front-seat passenger airbags



The indicator light for the front-seat passenger airbags indicates the operating state of the front-seat passenger airbags.

The light indicates whether the airbags are either activated or deactivated.



- ▶ The indicator light lights up when a child is properly seated in a child restraint system or when the seat is empty. The airbags on the front passenger side are not activated.

- ▶ The indicator light does not light up when, for instance a correctly seated person of sufficient size is detected on the seat. The airbags on the front passenger side are activated.

Detected child restraint systems

The system generally detects children seated in a child restraint system, particularly in child restraint systems required by NHTSA at the point in time when the vehicle was manufactured. After installing a child restraint system, make sure that the indicator light for the front-seat passenger airbags lights up. This indicates that the child restraint system has been detected and the front-seat passenger airbags are not activated.

Strength of the driver's and front-seat passenger airbag

The explosive power that activates driver's/front-seat passenger airbags very much depends on the positions of the driver's/front passenger seat.

To maintain the accuracy of this function over the long term, calibrate the front seats as soon as a respective message appears on the Control Display.

Calibrating the front seats

WARNING

There is a risk of jamming when moving the seats. There is a risk of injury or risk of damage to property. Make sure that the area of movement of the seat is clear prior to any adjustment.

A corresponding message appears on the Control Display.

1. Press the switch and move the respective seat all the way forward, until it stops.
2. Press the switch forward again. The seat still moves forward slightly.
3. Readjust the seat to the desired position.

The calibration procedure is completed when the message on the Control Display disappears.

If the message continues to be displayed, repeat the calibration.

If the message does not disappear after a repeat calibration, have the system checked as soon as possible.

Tire Pressure Monitor TPM

Concept

The system monitors tire inflation pressure in the four mounted tires. The system warns you if there is a significant loss of pressure in one or more tires.

General information

Sensors in the tire valves measure the tire inflation pressure and, depending on the model, the tire temperature.

With use of the system follow further information found under Tire inflation pressure, refer to page 226.

Functional requirements

The following conditions must be met for the system; otherwise, reliable flagging of a loss of tire inflation pressure is not assured:

- ▷ After a tire or wheel replacement, a reset was performed with the correct tire inflation pressure.
- ▷ After the tire inflation pressure was adjusted to a new value, a reset was performed.
- ▷ Wheels with TPM wheel electronics.

Status display

Current status

The system status can be displayed on the Control Display, e.g., whether or not the system is active.

Via iDrive:

1. "My Vehicle"
2. "Vehicle status"
3.  "Tire Pressure Monitor"

The current status is displayed.

Tire conditions

General information

Tire and system status are indicated by the color of the wheels and a SMS text message on the Control Display.

All wheels green

System is active and will issue a warning related to the tire inflation pressures stored during the last reset.

One to four yellow wheels

A flat tire or major drop in the tire inflation pressure has occurred in the indicated tires.

Gray wheels

It may not be possible to identify tire pressure losses.

Possible causes:

- ▷ Malfunction.
- ▷ The system is being reset.

Additional information

The status control display additionally shows the current tire inflation pressures and, depending on the model, tire temperatures. It shows the actual values read; they may vary depending on driving style or weather conditions.

Resetting the system

Via iDrive:

1. "My Vehicle"
2. "Vehicle status"
3.  "Tire Pressure Monitor"
4. Switch on drive-ready state and do not drive off.
5. Reset tire inflation pressure: "Perform reset".
6. Drive away.

The wheels are displayed in gray and the following is displayed "Resetting Tire Pressure Monitor...".

After driving faster than 19 mph/30 km/h for a short period, the set tire inflation pressures are accepted as reference values. The reset is completed automatically while driving.

After a successfully completed reset, the wheels on the Control Display are shown in green and



"Tire Pressure Monitor active. See label for recommended pressures." is displayed.

You may interrupt this trip at any time. When you continue the reset resumes automatically.

Messages

General information

A low tire inflation pressure may cause the DSC Dynamic Stability Control to be switched on.

Safety information

WARNING

A damaged regular tire with low or missing tire inflation pressure impacts handling, such as steering and braking response. There is a risk of an accident. Do not continue driving. Repair the flat tire or replace the wheel.

If a tire inflation pressure check is required

Message

A symbol with a Check Control message appears on the Control Display.

Symbol Possible cause



The system has detected a wheel change, but no reset was done.

Inflation was not carried out according to specifications.

The tire inflation pressure has fallen below the level of the last confirmation.

Measure

1. Check the tire pressure and correct as needed.
2. Carry out a reset of the system after a tire change.

At low tire inflation pressure

Message



A yellow warning light is illuminated in the instrument cluster.

In addition, a symbol with a Check Control message appears on the Control Display.

Symbol Possible cause



There is a flat tire or a major loss in tire inflation pressure.

No reset was performed for the system. The system therefore issues a warning based on the tire inflation pressures before the last reset.

Measure

1. Reduce your speed and stop cautiously. Avoid sudden braking and steering maneuvers.
2. Identify the damaged wheel. Check the air pressure in all four tires, for instance using the tire pressure gauge of a tire repair kit.
3. Repair the flat tire, for instance with a tire repair kit or by changing the tire.

If no tire repair kit is available, contact a dealer's service center or another qualified service center or repair shop.

System limits

Temperature

The tire inflation pressure depends on the tire's temperature.

Driving or exposure to the sun will increase the tire's temperature, thus increasing the tire inflation pressure.

The tire inflation pressure is reduced when the tire temperature falls again.

These circumstances may cause a warning when temperatures fall very sharply.



Sudden tire pressure loss

The system cannot indicate sudden serious tire damage caused by external circumstances.

Failure to perform a reset

The system does not function properly if a reset has not been carried out, for instance a flat tire is reported though tire inflation pressures are correct.

Malfunction



The yellow warning light flashes and is then illuminated continuously. A Check Control message is displayed. It may not be possible to identify tire pressure losses.

Examples and recommendations in the following situations:

- ▶ A wheel without TPM wheel electronics is mounted: have it checked by a dealer's service center or another qualified service center or repair shop as needed.
- ▶ Malfunction: have system checked by a dealer's service center or another qualified service center or repair shop.
- ▶ The system was unable to complete the reset. Perform a system reset again.
- ▶ Interference caused by systems or devices with the same radio frequency: after leaving the area of the interference, the system automatically becomes active again.

Declaration according to NHTSA/FMVSS 138 Tire Pressure Monitoring System

Each tire, including the spare (if provided) should be checked monthly when cold and inflated to the inflation pressure recommended by the vehicle manufacturer on the vehicle placard or tire inflation pressure label. (If your vehicle has tires of a different size than the size indicated on the vehicle placard or tire inflation pressure label, you should determine the proper tire inflation pressure for those tires.) As an added safety feature, your vehicle has been equipped with a tire pres-

sure monitoring system (TPMS) that illuminates a low tire pressure telltale when one or more of your tires is significantly under-inflated. Accordingly, when the low tire pressure telltale illuminates, you should stop and check your tires as soon as possible, and inflate them to the proper pressure. Driving on a significantly under-inflated tire causes the tire to overheat and can lead to tire failure. Under-inflation also reduces fuel efficiency and tire tread life, and may affect the vehicle's handling and stopping ability. Please note that the TPMS is not a substitute for proper tire maintenance, and it is the driver's responsibility to maintain correct tire pressure, even if under-inflation has not reached the level to trigger illumination of the TPMS low tire pressure telltale. Your vehicle has also been equipped with a TPMS malfunction indicator to indicate when the system is not operating properly. The TPMS malfunction indicator is combined with the low tire pressure telltale. When the system detects a malfunction, the telltale will flash for approximately one minute and then remain continuously illuminated. This sequence will continue upon subsequent vehicle start-ups as long as the malfunction exists. When the malfunction indicator is illuminated, the system may not be able to detect or signal low tire pressure as intended. TPMS malfunctions may occur for a variety of reasons, including the installation of replacement or alternate tires or wheels on the vehicle that prevent the TPMS from functioning properly. Always check the TPMS malfunction telltale after replacing one or more tires or wheels on your vehicle to ensure that the replacement or alternate tires and wheels allow the TPMS to continue to function properly.

FTM Flat Tire Monitor

Concept

The system detects tire inflation pressure loss on the basis of rotation speed differences between the individual wheels while driving.



In the event of a tire inflation pressure loss, the diameter and therefore the rotational speed of the corresponding wheel changes. The difference will be detected and reported as a flat tire.

The system does not measure the actual inflation pressure in the tires.

Functional requirements

The following conditions must be met for the system; otherwise, reliable flagging of a loss of tire inflation pressure is not assured:

- ▶ After a tire or wheel replacement, an initialization was performed with the correct tire inflation pressure.
- ▶ After the tire inflation pressure was adjusted to a new value, an initialization was performed.

Status display

The current status of the flat tire monitor can be displayed, for instance whether the RPA is active.

Via iDrive:

1. "My Vehicle"
2. "Vehicle status"
3.  "Flat Tire Monitor"

The status is displayed.

Initialization required

An initialization must be performed in the following situations:

- ▶ After the tire inflation pressure has been adjusted.
- ▶ After a tire or wheel replacement.

Performing initialization

When initializing, the set tire inflation pressures serve as reference values in order to detect a flat tire. Initialization is started by confirming the tire inflation pressures.

Do not initialize the system when driving with snow chains.

Via iDrive:

1. "My Vehicle"
2. "Vehicle status"
3.  "Flat Tire Monitor"
4. Switch on drive-ready state and do not drive off.
5. Start the initialization with: "Perform reset"
6. Drive away.

The initialization is completed while driving, which can be interrupted at any time.

The initialization automatically continues when driving resumes.

Messages

General information

When a flat tire is indicated, DSC Dynamic Stability Control is switched on, if needed.

Safety information

WARNING

A damaged regular tire with low or missing tire inflation pressure impacts handling, such as steering and braking response. There is a risk of an accident. Do not continue driving. Repair the flat tire or replace the wheel.

Indication of a flat tire



A yellow warning light is illuminated in the instrument cluster.

In addition, a symbol with a Check Control message appears on the Control Display.

Symbol	Possible cause
	There is a flat tire or a major loss in tire inflation pressure.



There is a flat tire or a major loss in tire inflation pressure.



Measure

1. Reduce your speed and stop cautiously. Avoid sudden braking and steering maneuvers.
2. Identify the damaged wheel. Check the air pressure in all four tires, for instance using the tire pressure gage of a tire repair kit.
3. Repair the flat tire, e.g., with a flat tire kit or by changing the wheel.

If no tire repair kit is available, contact a dealer's service center or another qualified service center or repair shop.

System limits

The system could be delayed or malfunction in the following situations:

- ▶ A natural, even tire inflation pressure loss in all four tires will not be recognized. Therefore, check the tire inflation pressure regularly.
- ▶ Sudden serious tire damage caused by external circumstances cannot be recognized in advance.
- ▶ When the system has not been initialized.
- ▶ When driving on a snowy or slippery road surface.
- ▶ Sporty driving style: spinning traction wheels, high lateral acceleration (drifting).
- ▶ When driving with snow chains.

Intelligent Safety

Concept

Intelligent Safety enables central operation of the driver assistance system.

The intelligent safety systems can help prevent an imminent collision.

- ▶ Approach control warning with City light braking function, refer to page 142.
- ▶ Person warning with City light braking function, refer to page 145.

Safety information

WARNING

The system cannot serve as a substitute for the driver's personal judgment in assessing visibility and traffic situation. There is a risk of an accident. Adjust driving style to traffic conditions. Watch traffic closely and actively intervene where appropriate.

WARNING

Indicators and warnings cannot serve as a substitute for the driver's personal judgment. Due to its limits, the system might not output warnings or reactions or these might be output late, incorrectly, or without justification. There is a risk of an accident. Adjust driving style to traffic conditions. Watch traffic closely and actively intervene where appropriate.

Overview

Button in the vehicle



Intelligent Safety button

Switching on/off

Some Intelligent Safety systems are automatically active after every departure. Some Intelligent Safety systems activate according to the last setting.



Press button briefly:

- ▶ The menu for the intelligent safety system is displayed. The systems are individually switched off according to their respective settings.
- ▶ LED lights up orange or goes out respective to their individual settings.

Adjust as needed. Individual settings are stored for the profile currently used.



Press button again:

- ▶ All Intelligent Safety systems are switched on.
- ▶ The LED lights up green.



Hold down button:

- ▶ All Intelligent Safety systems are switched off.
- ▶ The LED goes out.

Approach control warning with City light braking function

Concept

The system can help prevent accidents. If an accident cannot be prevented, the system will help reduce the collision speed.

The system sounds a warning before an imminent collision and activates brakes independently, if needed.

The automatic braking intervention is done with limited force and duration.

A camera in the area of the interior mirror controls the system.

The approach control warning is available even if cruise control has been deactivated.

With the vehicle approaching another vehicle intentionally, the approach control warning and braking are delayed in order to avoid false system reactions.

General information

The system warns at two levels of an imminent danger of collision at speeds from approx. 3 mph/5 km/h. Time of warnings may vary with the current driving situation.

Appropriate braking kicks in at speeds of up to 35 mph/60 km/h.

Detection range

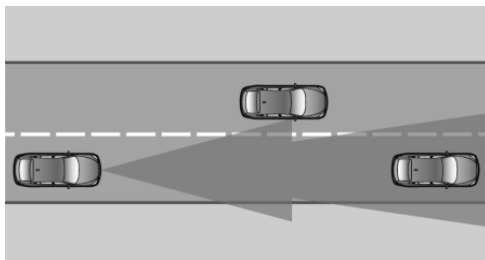

Objects that the system can detect are taken into account.

Safety information

WARNING

The system cannot serve as a substitute for the driver's personal judgment in assessing visibility and traffic situation. There is a risk of an accident. Adjust driving style to traffic conditions. Watch traffic closely and actively intervene where appropriate.

WARNING

Indicators and warnings cannot serve as a substitute for the driver's personal judgment. Due to its limits, the system might not output warnings or reactions or these might be output late, incorrectly, or without justification. There is a risk of an accident. Adjust driving style to traffic conditions. Watch traffic closely and actively intervene where appropriate.

Overview

Button in the vehicle



 Intelligent Safety button

Camera

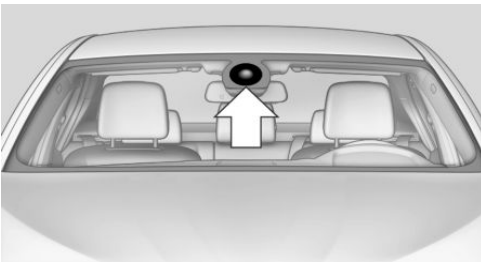

The camera is installed near the interior mirror.
Keep the windshield in front of the interior mirror clean and clear.

Switching on/off

Switching on automatically



The system is automatically active after every driving off.

Switching on/off manually

-  Press button briefly:
- ▶ The menu for the intelligent safety system is displayed. The systems are individually switched off according to their respective settings.

- ▶ LED lights up orange or goes out respective to their individual settings.

Adjust as needed. The individual settings are stored for the driver profile currently in use.

-  Press button again:
 - ▶ All Intelligent Safety systems are switched on.
 - ▶ The LED lights up green.
-  Hold down button:
 - ▶ All Intelligent Safety systems are switched off.
 - ▶ The LED goes out.

Setting the warning time

The warning time can be set.

Via iDrive:



1. "My Vehicle"
2. "Vehicle settings"
3. "Intelligent Safety"
4. "Warning time"
5. Select the desired setting.

The selected time is stored for the driver profile currently used.

Warning with braking function

Display

If a collision with a vehicle detected in this way is imminent, a warning symbol appears on the instrument cluster.

Symbol	Measure
	Symbol lights up red: prewarning. Brake and increase distance.
	Symbol flashes red and an acoustic signal sounds: acute warning. Brake and make an evasive maneuver, if necessary.



Prewarning

This warning is issued, for instance when there is the impending danger of a collision or the distance to the vehicle ahead is too small.

The driver must intervene actively when there is a prewarning.

Acute warning with braking function

Acute warning is displayed in case of the imminent danger of a collision when the vehicle approaches another object at a high differential speed.

The driver must intervene actively when there is an acute warning. If necessary, the driver is assisted by a minor automatic braking intervention in a possible risk of collision.

Acute warnings can also be triggered without previous forewarning.

Braking intervention

The warning prompts the driver to react. During a warning, the maximum braking force is used. Prerequisite for the brake booster is sufficiently quick and hard stepping on the brake pedal. If there is a risk of collision, the system may assist with braking. When the vehicle is traveling at a low speed, the vehicle may come to a complete stop.

The braking intervention occurs only if vehicle stability has not been restricted, for instance by deactivating the DSC Dynamic Stability Control.

The braking intervention can be interrupted by stepping on the accelerator pedal or by actively moving the steering wheel.

Object detection can be restricted. Follow the limitations of the detection range and functional restrictions.

System limits

Safety information

WARNING

The system can react not at all, too late, incorrectly, or without justification due to the system limits. There is a risk of accidents or risk of damage to property. Follow the information regarding the system limits and actively intervene if needed.

Detection range

The system's detection potential is limited.

Thus, a system reaction might not come or might come late.

E.g., the following situations may not be detected:

- ▶ Slow moving vehicles when you approach them at high speed.
- ▶ Vehicles that suddenly swerve in front of you, or sharply decelerating vehicles.
- ▶ Vehicles with an unusual rear appearance.
- ▶ Two-wheeled vehicles ahead of you.

Functional limitations

The system may not be fully functional in the following situations:

- ▶ In heavy fog, wet conditions, or snowfall.
- ▶ In tight curves.
- ▶ If the driving stability control systems are deactivated, for instance DSC OFF.
- ▶ If the field of view of the camera in the mirror is dirty or obscured.
- ▶ Up to 10 seconds after drive-ready state is established.
- ▶ During calibration of the camera immediately after vehicle delivery.



- ▶ If there are constant blinding effects because of oncoming light, for instance from the sun low in the sky.

Warning sensitivity

The more sensitive the warning settings are, for example the warning time, the more warnings are displayed. Therefore, there may also be an excess of premature or unjustified warnings and reactions.

Person warning with City light braking function

Concept

The system can help prevent accidents with pedestrians.

When driving at city speeds, the system will issue a warning if there is imminent risk of a collision with pedestrians, and support this with a light braking function.

The camera in the area of the interior mirror controls the system.

General information

With sufficient brightness, the system warns about possible collision danger with pedestrians starting at approx. 6 mph/10 km/h to approx. 35 mph/60 km/h and assists with braking before a collision.

The system reacts to people who are within the detection range of the system.

Detection range

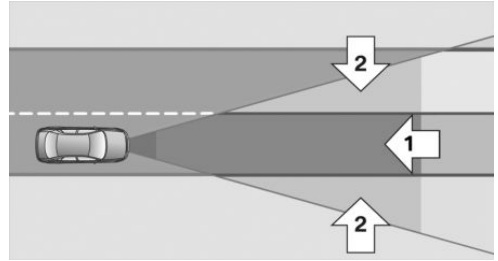

The detection area in front of the vehicle is divided into two areas:

- ▶ Central area, arrow 1, directly in front of the vehicle.
- ▶ Expanded area, arrow 2, to the right and left of the central area.

A collision is imminent if pedestrians are located within the central area. A warning is issued about pedestrians who are located within the extended area only if they are moving in the direction of the central area.

Safety information

WARNING

The system cannot serve as a substitute for the driver's personal judgment in assessing visibility and traffic situation. There is a risk of an accident. Adjust driving style to traffic conditions. Watch traffic closely and actively intervene where appropriate.

WARNING

Indicators and warnings cannot serve as a substitute for the driver's personal judgment. Due to its limits, the system might not output warnings or reactions or these might be output late, incorrectly, or without justification. There is a risk of an accident. Adjust driving style to traffic conditions. Watch traffic closely and actively intervene where appropriate.



Overview

Button in the vehicle



 Intelligent Safety button

Camera

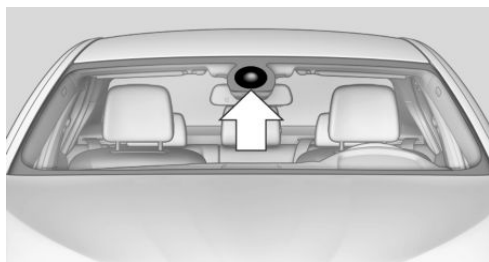

The camera is installed near the interior mirror. Keep the windshield in front of the interior mirror clean and clear.

Switching on/off

Switching on automatically

The system is automatically active after every driving off.

Switching on/off manually

-  Press button briefly:
 - ▶ The menu for the intelligent safety system is displayed. The systems are individually switched off according to their respective settings.

- ▶ LED lights up orange or goes out respective to their individual settings.

Adjust as needed. The individual settings are stored for the driver profile currently in use.

-  Press button again:
 - ▶ All Intelligent Safety systems are switched on.
 - ▶ The LED lights up green.

-  Hold down button:
 - ▶ All Intelligent Safety systems are switched off.
 - ▶ The LED goes out.

Warning with braking function

Display

If a collision with a person detected in this way is imminent, a warning symbol appears on the instrument cluster.



The red symbol is displayed and a signal sounds.

Intervene immediately by braking or make an evasive maneuver.

Braking intervention

The warning prompts the driver to react. During a warning, the maximum braking force is used. Prerequisite for the brake booster is sufficiently quick and hard stepping on the brake pedal. If there is a risk of collision, the system may assist with braking. When the vehicle is traveling at a low speed, the vehicle may come to a complete stop.

The braking intervention occurs only if vehicle stability has not been restricted, for instance by deactivating the DSC Dynamic Stability Control.

The braking intervention can be interrupted by stepping on the accelerator pedal or by actively moving the steering wheel.

Object detection can be restricted. Follow the limitations of the detection range and functional restrictions.

System limits

Safety information

WARNING

The system can react not at all, too late, incorrectly, or without justification due to the system limits. There is a risk of accidents or risk of damage to property. Follow the information regarding the system limits and actively intervene if needed.

Detection range

The detection potential of the camera is limited. Thus, a warning might not be issued or be issued late.

E.g., the following situations may not be detected:

- ▶ Partially covered pedestrians.
- ▶ Pedestrians that are not detected as such because of the viewing angle or contour.
- ▶ Pedestrians outside of the detection range.
- ▶ Pedestrians having a body size less than 32 in/80 cm.

Functional limitations

The system may not be fully functional or may not be available in the following situations:

- ▶ In heavy fog, wet conditions, or snowfall.
- ▶ In tight curves.
- ▶ If the driving stability control systems are deactivated, for instance DSC OFF.
- ▶ If the field of view of the camera or the windshield are dirty or covered.
- ▶ Up to 10 seconds after drive-ready state is established.

- ▶ During calibration of the camera immediately after vehicle delivery.
- ▶ If there are constant blinding effects because of oncoming light, for instance from the sun low in the sky.
- ▶ When it is dark outside.

Brake force display

Concept

Additional brake lights indicate emergency braking to the traffic behind. This can reduce the risk of a rear-end collision.

General information



- ▶ During normal braking or decelerating, the top brake lights light up.
- ▶ During heavy brake application, the lower brake lights additionally light up.

PostCrash – iBrake

Concept

In the event of an accident, the system can bring the vehicle to a halt automatically without intervention by the driver in certain situations. This can reduce the risk of a further collision and the consequences thereof.



Harder vehicle braking

It can be necessary to bring the vehicle in certain situations to a halt quicker.

To do this, for a short time the braking pressure applied when stepping on the brake pedal must be higher than the braking pressure achieved by the automatic braking function. This interrupts automatic braking.

Interrupting automatic braking

It can be necessary to interrupt automatic braking in certain situations, for example for an evasive maneuver.

Interrupt automatic braking:

- ▷ By pressing the brake pedal.
- ▷ By pressing the accelerator pedal.

At standstill

After coming to a halt, the brake is released automatically.



Driving stability control systems

Vehicle features and options

This chapter describes all standard, country-specific and optional features offered with the series. It also describes features that are not necessarily available in your vehicle, e. g., due to the selected options or country versions. This also applies to safety-related functions and systems. When using these functions and systems, the applicable laws and regulations must be observed.

Anti-lock Braking System ABS

ABS prevents locking of the wheels during braking.

The vehicle maintains its steering power even during full brake applications, thus increasing active safety.

ABS is ready when vehicle is ready to drive.

Brake assistant

When you apply the brakes rapidly, this system automatically boosts the vehicle braking capability to the furthest possible extent. It reduces the braking distance to a minimum during emergency stop. This system utilizes all of the capabilities provided by the Antilock Brake System ABS.

Do not reduce the pressure on the brake pedal for the duration of the emergency stop.

Energy recovery

General information

In the event of danger, such as with locked wheels, energy recovery is reduced in order to prevent unstable driving situations.

Safety information

WARNING

Without energy recovery, there is no braking power of the electric motor available. The vehicle could roll further than anticipated. There is a risk of an accident. Adjust driving style to traffic conditions. Watch traffic closely and actively intervene where appropriate.

DSC Dynamic Stability Control

Concept

Within the physical limits, the system helps to keep the vehicle on a steady course by reducing engine speed and by applying brakes to the individual wheels.

General information

DSC detects the following unstable driving conditions, for instance:

- ▷ Fishtailing, which can lead to oversteering.
- ▷ Loss of traction of the front wheels, which can lead to understeering.

Dynamic Traction Control DTC, refer to page 150, is a version of the DSC where forward momentum is optimized.

Safety information

WARNING

The system cannot serve as a substitute for the driver's personal judgment in assessing the traffic situation. Based on the limits of the system, it cannot independently react to all traffic situations. There is a risk of an accident. Adjust driving style to traffic conditions. Watch traffic



closely and actively intervene where appropriate.

Indicator/warning lights



The indicator light flashes: DSC controls the drive and braking forces.

The indicator light lights up: DSC has malfunctioned.

DTC Dynamic Traction Control

Concept

DTC is a version of the DSC Dynamic Stability Control where forward momentum is optimized.

The system ensures maximum headway on special road conditions or loose road surfaces, for instance unplowed snowy roads, but with somewhat limited driving stability.

When DTC is activated, the vehicle has maximum traction. Driving stability is limited during acceleration and when driving in curves.

Drive carefully.



You may find it useful to briefly activate DTC under the following special circumstances:

- ▷ When driving in slush or on uncleared, snow-covered roads.
- ▷ When driving off from deep snow or loose ground.
- ▷ When driving with snow chains.

Deactivating/activating DTC Dynamic Traction Control

Activating DTC

Via iDrive:

1. "My Vehicle"
2.  "Traction control"
3.  "TRACTION"

TRACTION and the DSC OFF indicator light lights up.

Deactivating DTC

Via iDrive:

1. "My Vehicle"
2.  "Traction control"
3. "DSC ON"

TRACTION and the DSC OFF indicator light go out.

When drive-ready state is switched on, DTC is automatically deactivated.

Driving Dynamics Control

Concept

The Driving Dynamics Control helps to fine-tune the vehicle's settings and features. Various programs can be selected for this purpose.

Overview

Button in the vehicle



Operating the programs

Driving Dynamics Control	Program
	i3s: SPORT
	COMFORT
	ECO PRO
	ECO PRO+

COMFORT

Concept

For balanced tuning.

Activating COMFORT



Press button repeatedly until COMFORT is displayed in the instrument cluster.

ECO PRO

Concept

ECO PRO, refer to page 205, provides consistent tuning to maximize range.

Comfort functions and the engine Controller are adjusted.

The program can be configured to individual specifications.

Activating ECO PRO



Press button repeatedly until ECO PRO is displayed in the instrument cluster.

Configuring ECO PRO

Via iDrive:

1. "My Vehicle"
2. "Vehicle settings"
3. "Configure ECO PRO"
4. Select the desired setting.

The setting is stored for the driver profile currently used.

ECO PRO+

Concept

ECO PRO+, refer to page 205, also limits the maximum speed and reduces climate control and lighting functions.

Comfort functions and the engine Controller are adjusted.

Activating ECO PRO+



Press button repeatedly until ECO PRO+ is displayed in the instrument cluster.

i3s: SPORT

Concept

Sporty tuning of the steering and drivetrain for greater driving agility.

Activating SPORT



Press button repeatedly until SPORT is displayed in the instrument cluster.

Displays

Program selection

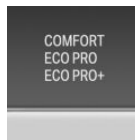

Pressing the button displays a list of the selectable programs. Depending on your vehicle's optional features, the list in the instrument cluster can differ from the illustration shown.

Selected program

The ECO PRO and ECO PRO+ driving programs are shown in the instrument cluster. In addition, the display on the automatic climate control lights up.

i3s: the SPORT driving program is displayed in the instrument cluster.

Drive-off assistant

Concept

This system supports driving off on uphill grades. The parking brake is not required.



Driving off with the drive-off assistant

1. Hold the vehicle in place with the foot brake.
2. Release the foot brake and drive off without delay.

After the foot brake is released, the vehicle is held in place for approx. 2 seconds.

Depending on the vehicle load or when a trailer is used, the vehicle may roll back slightly.

Driving comfort

Vehicle features and options

This chapter describes all standard, country-specific and optional features offered with the series. It also describes features that are not necessarily available in your vehicle, e. g., due to the selected options or country versions. This also applies to safety-related functions and systems. When using these functions and systems, the applicable laws and regulations must be observed.

Camera-based cruise control with Stop & Go function ACC

Concept

Using this system, a desired speed and a distance to a vehicle ahead can be adjusted using the buttons on the steering wheel.

The system maintains the desired speed on clear roads. For this purpose, the vehicle accelerates or brakes automatically.

If a vehicle is driving ahead of you, the system adjusts the speed of your vehicle so that the set distance to the vehicle ahead is maintained. The speed is adjusted as far as the given situation allows.

The distance can be adjusted in several steps. For safety reasons, it depends on the respective speed.

If the vehicle ahead of you brakes to a halt, and then proceeds to drive again within a brief period, the system is able to detect this within the given system limits.

General information

A camera on the interior mirror is used to detect vehicles driving ahead.

Depending on the driving settings, the features of the cruise control can change in certain areas.

Safety information

WARNING

The system cannot serve as a substitute for the driver's personal judgment in assessing the traffic situation. Based on the limits of the system, it cannot independently react to all traffic situations. There is a risk of an accident. Adjust driving style to traffic conditions. Watch traffic closely and actively intervene where appropriate.

WARNING

An unsecured vehicle can begin to move and possibly roll away. There is a risk of an accident. Before exiting, secure the vehicle against rolling.

In order to ensure that the vehicle is secured against rolling away, follow the following:

- ▷ Set the parking brake.
- ▷ On uphill grades or on a downhill slope, turn the front wheels in the direction of the curb.
- ▷ On uphill grades or on a downhill slope, also secure the vehicle, for instance with a wheel chock.

WARNING

The desired speed can be incorrectly adjusted or called up by mistake. There is a risk of an accident. Adjust the desired speed to the traffic conditions. Watch traffic closely and actively intervene where appropriate.

**WARNING**

Risk of accident due to too high speed differences to other vehicles, for instance in the following situations:

- ▷ When fast approaching a slowly moving vehicle.
- ▷ Vehicle suddenly swerving into own lane.
- ▷ When fast approaching standing vehicles.

There is a risk of injuries or danger to life. Watch traffic closely and actively intervene where appropriate.

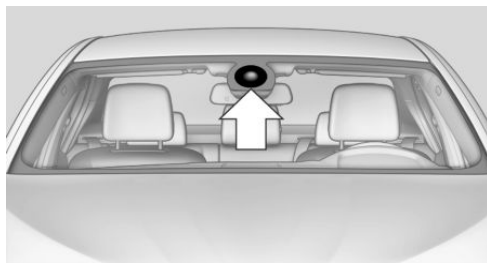

Keep the windshield in front of the interior mirror clean and clear.

Overview

Buttons on the steering wheel

Button	Function
	Cruise control on/off, interrupting, refer to page 154.
	Store/maintain speed, refer to page 155.
	Resume speed, continue cruise control, refer to page 156.
	Adjust distance, refer to page 156.
	Rocker switch: Set speed, refer to page 155.

Camera

A camera in the area of the interior mirror serves to detect vehicles.

Functional requirements

Speed range

The system is best used on well-constructed roads.

The desired speed can be set between 20 mph/30 km/h and 85 mph/140 km/h.

The system can also be activated when stationary.

Switching on/off and interrupting cruise control

Switching on

 Press button on the steering wheel.

 The indicator light in the instrument cluster lights up.

 Desired speed becomes current speed and will be displayed - beside the symbol - in the Info Display.

Cruise control can be used.

DSC Dynamic Stability Control is switched on, if necessary.

Switching off

To switch off the system while standing, step on brake pedal at the same time.



Press button on the steering wheel.

- ▶ If active: press twice.
- ▶ If interrupted: press once.

The displays go out. The stored desired speed is deleted.

Interrupting manually



Press button on the steering wheel.

If interrupting the system while stationary, press on the brake pedal at the same time.

Interrupting automatically

The system is automatically interrupted in the following situations:

- ▶ When the driver applies the brakes.
- ▶ When selector lever position D is disengaged.
- ▶ When Dynamic Traction Control DTC is activated.
- ▶ If DSC Dynamic Stability Control intervenes.
- ▶ If the safety belt is unbuckled and the driver's door is opened while the vehicle is standing still.
- ▶ If the detection range of the camera is impaired, for instance by soiling, heavy precipitation or glare effects from the sun.
- ▶ After a stationary period of approx. 3 seconds when the vehicle has been braked to a stop by the system.

Setting the speed

Maintaining/storing the speed

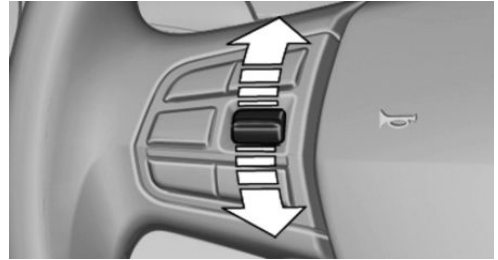

Press the rocker switch up or down once while the system is interrupted.

When the system is switched on, the current speed is maintained and stored as the desired speed.

The stored speed is displayed in the speedometer and permanently in the instrument cluster, refer to page 156.

DSC Dynamic Stability Control is switched on, if necessary.



The speed can also be stored by pressing a button.

Press button.

Changing the speed

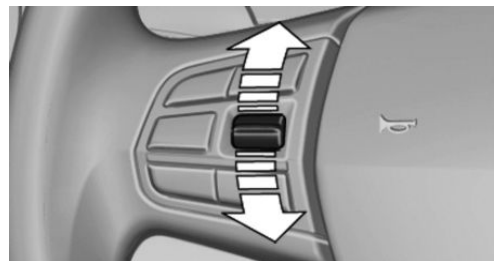

Press the rocker switch up or down repeatedly until the desired speed is set.

If active, the displayed speed is stored and the vehicle reaches the stored speed when the road is clear.



- ▶ Each time the rocker switch is pressed to the point of resistance, the desired speed increases or decreases by approx. 1 mph/1 km/h.
- ▶ Each time the rocker switch is pressed past the resistance point, the desired speed changes by a maximum of 5 mph/10 km/h.

Hold the rocker switch in position to repeat the action.

Adjusting distance

Safety information

WARNING

The system cannot serve as a substitute for the driver's personal judgment. Due to the system limits, braking can be late. There is a risk of accidents or risk of damage to property. Be aware to the traffic situation at all times. Adjust the distance to the traffic and weather conditions and maintain the prescribed safety distance, possibly by braking.

Adjusting



Press button repeatedly until the desired distance is set.



The set distance is briefly displayed in the left part of the instrument cluster.

Continuing cruise control

General information

An interrupted cruise control can be continued by calling up the stored speed.

Make sure that the difference between current speed and stored speed is not too large before calling up the stored speed. Otherwise, unintentional braking or accelerating may occur.

In the following cases, the stored speed value is deleted and cannot be called up again:

- ▶ When the system is switched off.
- ▶ When drive-ready state is switched off.

Calling up stored speed and distance



Press button with the system switched on.

Desired speed and distance are then continued with these settings. The instrument cluster briefly displays the selected distance.

Switching distance control on/off

Safety information

WARNING

The system does not react to traffic driving ahead of you, but instead maintains the stored speed. There is a risk of accidents or risk of damage to property. Adjust the desired speed to the traffic conditions and brake as needed.

Switching distance control off

Distance control can be switched off and on when driving with cruise control activated.



Press and hold this button.



The indicator light in the instrument cluster lights up.

To switch distance control back on, press button again briefly.

After changing over distance control, a Check Control message is displayed.

Displays in the instrument cluster

Desired speed and stored speed



The desired speed is displayed next to the symbol in the Info Display.

- ▶ Display lights up green: system is active, the display indicates the desired speed.
- ▶ Display lights up orange: system is interrupted, the display indicates the stored speed.
- ▶ No display: system is switched off.

Status display



Selected desired speed.

If no speed is indicated, it is possible that the conditions necessary for operation are not currently fulfilled.

Distance to vehicle ahead of you

Selected distance from the vehicle driving ahead is briefly displayed in the left hand portion of the instrument cluster.

Distance display



Distance 1



Distance 2



Distance 3



Distance 4

This value is set after the system is switched on.

Detected vehicle



Symbol lights up orange:

A vehicle has been detected ahead of you.



Distance control is deactivated because the accelerator pedal is being pressed; a vehicle was detected.



Flashing bar: the detected vehicle has driven away.

ACC does not accelerate. To accelerate, activate ACC by stepping on the accelerator pedal or pressing the RES button or the rocker switch.

Indicator/warning lights



Symbol flashes orange:

The conditions are not adequate for the system to work.

The system was deactivated but applies the brakes until you actively resume control by pressing on the brake pedal or accelerator pedal.



Symbol flashes red and a signal sounds:

Brake and make an evasive maneuver, if necessary.



The system has been interrupted or distance control is deactivated because the accelerator pedal is being pressed; a vehicle was not detected.

System limits

Detection range

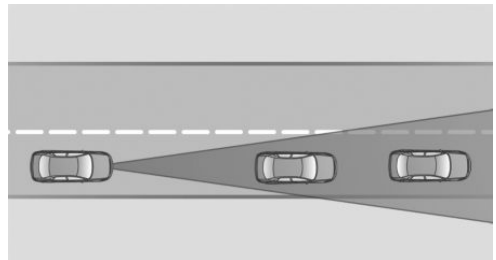

The detection capacity of the system and the automatic braking capacity are limited.

Two-wheeled vehicles for instance might not be detected.



Deceleration

The system does not decelerate in the following situations:

- ▶ For pedestrians, cyclists or similarly slow-moving road users.
- ▶ For red traffic lights.
- ▶ For cross traffic.
- ▶ For oncoming traffic.
- ▶ Unlit vehicles or vehicles with nonworking lighting at night.

Swerving vehicles

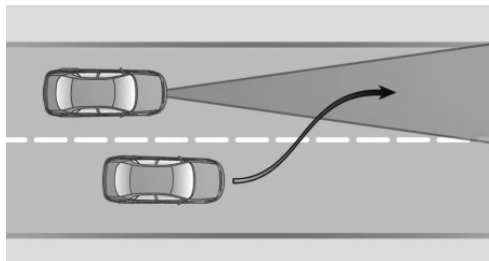

A vehicle driving in front of you is not detected until it is completely within the same lane as your vehicle.

If a vehicle driving ahead of you suddenly swerves into your lane, the system may not be able to automatically restore the selected distance. It may not be possible to restore the selected distance in certain situations, including if you are driving significantly faster than vehicles driving ahead of you, for instance when rapidly approaching a truck. When a vehicle driving ahead of you is reliably detected, the system requests that the driver intervene by braking and carrying out evasive maneuvers, if needed.

Cornering

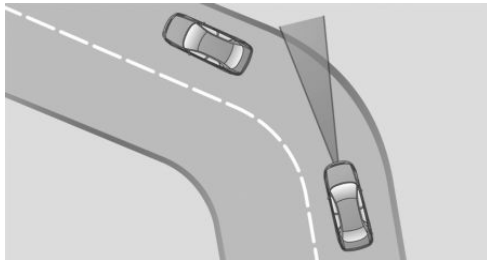

If the desired speed is too high for a curve, the speed is reduced slightly, although curves cannot be anticipated in advance. Therefore, drive into a curve at an appropriate speed.

The system has a limited detection range. Situations can arise in tight curves where a vehicle driving ahead will not be detected or will be detected very late.

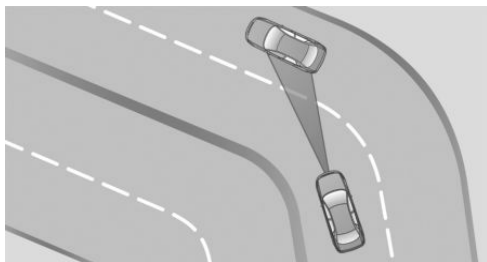

When you approach a curve the system may briefly report vehicles in the next lane due to the bend of the curve. If the system decelerates you may compensate it by briefly accelerating.

After releasing the accelerator pedal the system is reactivated and controls speed independently.

Driving away

In some situations, the vehicle cannot drive off automatically; for example:

- ▶ On steep uphill grades.
- ▶ From bumps in the road.

In these cases, step on the accelerator pedal.

Weather

The following restrictions can occur under unfavorable weather or light conditions:

- ▷ Poorer vehicle recognition.
- ▷ Short-term interruptions for vehicles that are already recognized.

Examples of unfavorable weather or light conditions:

- ▷ Wet conditions.
- ▷ Snowfall.
- ▷ Slush.
- ▷ Fog.
- ▷ Glare.

Drive attentively, and react to the current traffic situation. If necessary, intervene actively, for instance by braking, steering or evading.

Engine power

The desired speed is also maintained downhill, but may not be maintained on uphill grades if engine power is insufficient.

Malfunction

A Check Control message is displayed if the system fails.

The system may not be fully functional in the following situations:

- ▷ When an object was not correctly detected.
- ▷ In heavy fog, rain, sprayed water or snowfall.
- ▷ In tight curves.
- ▷ If the field of view of the camera or the windshield are dirty or covered.
- ▷ When driving toward bright lights.
- ▷ Up to 20 seconds after drive-ready state is switched on via the Start/Stop button.
- ▷ During calibration of the camera immediately after vehicle delivery.

Cruise control

Concept

Using this system, a desired speed can be adjusted using the buttons on the steering wheel. The system maintains the desired speed. The system accelerates and brakes automatically as needed.

General information

Depending on the driving settings, the features of the cruise control can change in certain areas.

Safety information

WARNING

The system cannot serve as a substitute for the driver's personal judgment in assessing the traffic situation. Based on the limits of the system, it cannot independently react to all traffic situations. There is a risk of an accident. Adjust driving style to traffic conditions. Watch traffic closely and actively intervene where appropriate.

WARNING

The use of the system can lead to an increased risk of accidents in the following situations, for instance:

- ▷ On winding roads.
- ▷ In heavy traffic.
- ▷ On slippery roads, in fog, snow, or wet conditions, or on a loose road surface.

There is a risk of accidents or risk of damage to property. Only use the system if driving at constant speed is possible.

**WARNING**

The desired speed can be incorrectly adjusted or called up by mistake. There is a risk of an accident. Adjust the desired speed to the traffic conditions. Watch traffic closely and actively intervene where appropriate.

Overview

Buttons on the steering wheel

Button	Function
	Cruise control on/off, interrupting, refer to page 160.
	Store speed, refer to page 160.
	Resume speed, continue cruise control, refer to page 161.
	Rocker switch: Set speed, refer to page 160.

Switching on/off and interrupting cruise control

Switching on

 Press button on the steering wheel.

 The indicator light in the instrument cluster lights up.

 Desired speed becomes current speed and will be displayed - beside the symbol - in the Info Display.

Cruise control can be used.

DSC Dynamic Stability Control is switched on, if necessary.

Switching off

 Press button on the steering wheel.

- ▶ If active: press twice.
- ▶ If interrupted: press once.

The displays go out. The stored desired speed is deleted.

Interrupting manually

 When active, press the button on the steering wheel.

Interrupting automatically

The system is automatically interrupted in the following situations:

- ▶ When the driver applies the brakes.
- ▶ When selector lever position D is disengaged.
- ▶ When Dynamic Traction Control DTC is activated.
- ▶ If DSC Dynamic Stability Control intervenes.

Setting the speed

Maintaining/storing the speed

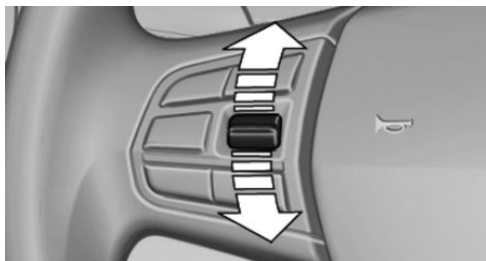

Press the rocker switch up or down once while the system is interrupted.

When the system is switched on, the current speed is maintained and stored as the desired speed.

The stored speed is displayed in the instrument cluster.



DSC Dynamic Stability Control is switched on, if necessary.

The speed can also be stored by pressing a button.

SET

Press button.

Changing the speed

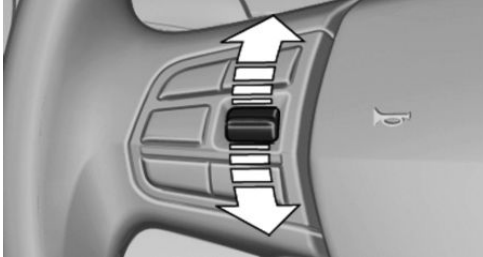

Press the rocker switch up or down repeatedly until the desired speed is set.

If active, the displayed speed is stored and the vehicle reaches the stored speed when the road is clear.

- ▶ Each time the rocker switch is pressed to the point of resistance, the desired speed increases or decreases by approx. 1 mph/1 km/h.
- ▶ Each time the rocker switch is pressed past the point of resistance, the desired speed increases or decreases by a maximum of 5 mph/10 km/h.

The maximum speed that can be set depends on the vehicle.

- ▶ Pressing the rocker switch to the resistance point and holding it accelerates or decelerates the vehicle without requiring pressure on the accelerator pedal.

After the rocker switch is released, the vehicle maintains its final speed. Pressing the switch beyond the resistance point causes the vehicle to accelerate more rapidly.

Continuing cruise control

General information

An interrupted cruise control can be continued by calling up the stored speed.

Make sure that the difference between current speed and stored speed is not too large before calling up the stored speed. Otherwise, unintentional braking or accelerating may occur.

In the following cases, the stored speed value is deleted and cannot be called up again:

- ▶ When the system is switched off.
- ▶ When drive-ready state is switched off.

Calling up stored speed

RES

Press button on the steering wheel.

The stored speed is reached again and maintained.

Displays in the instrument cluster

Indicator light



Depending on how the vehicle is equipped, the indicator light in the instrument cluster indicates whether the system is switched on.

Desired speed and stored speed



The desired speed is displayed next to the symbol in the Info Display.

- ▶ Display lights up green: system is active, the display indicates the desired speed.
- ▶ Display lights up orange: system is interrupted, the display indicates the stored speed.
- ▶ No display: system is switched off.



Status display



Selected desired speed.

If no speed is indicated, it is possible that the conditions necessary for operation are not currently fulfilled.

System limits

Engine power

The desired speed is also maintained downhill, but may not be maintained on uphill grades if engine power is insufficient.

PDC Park Distance Control

Concept

PDC is a support when parking. The system detects objects behind the vehicle. If the vehicle is equipped with front PDC, objects in front of the vehicle are detected too. Objects that you are approaching slowly are indicated by signal tones and a display on the Control Display.

General information

The ultrasound sensors for measuring the distances are located in the bumpers.

The maneuvering range, depending on the obstacle and environmental conditions, is approx. 6 ft/2 m.

An acoustic warning is first given in the following situations:

- ▷ By the front sensors and the two rear corner sensors at approx. 24 in/60 cm from the object.
- ▷ By the rear middle sensors at a distance to the object of approx. 5 ft/1.50 m.
- ▷ When a collision is imminent.

Safety information

WARNING

The system cannot serve as a substitute for the driver's personal judgment in assessing the traffic situation. Based on the limits of the system, it cannot independently react to all traffic situations. There is a risk of an accident. Adjust driving style to traffic conditions. Watch traffic closely and actively intervene where appropriate.

WARNING

Due to high speeds when PDC Park Distance Control is activated, the warning can be delayed due to physical circumstances. There is a risk of injury or risk of damage to property. Avoid approaching an object too fast. Avoid driving off fast while PDC Park Distance Control is not yet active.

Overview

With front PDC: button in vehicle



Park assistance button

Ultrasound sensors



Ultrasound sensors of the PDC, for instance in the bumpers.

Functional requirements

Ensure full functionality:

- ▶ Do not cover sensors, for instance with stickers, bicycle racks.
- ▶ Keep the sensors clean and unobstructed.

Switching on/off

Switching on automatically

The system switches on automatically in the following situations:

- ▶ If selector lever position R is engaged while drive-ready state is switched on.
The rearview camera also switches on.
- ▶ If equipped with front PDC: when obstacles are detected behind or in front of the vehicle by PDC and the speed is slower than approx. 2.5 mph/4 km/h.

You may switch automatic activation on and off when obstacles are detected. Via iDrive:

1. "My Vehicle"
2. "Vehicle settings"
3. "Parking"
4. "Automatic PDC activation": depending on the vehicle equipment.
5. "Automatic PDC activation"
The setting is stored for the driver profile currently used.

If necessary, switch off automatic PDC activation on obstacle detection, for instance in vehicle washes, to reduce false alarms.

Automatic deactivation during forward travel

The system switches off when a certain driving distance or speed is exceeded.

Switch the system back on, if needed.

With front PDC: switching on/off manually



Press park assistance button.

- ▶ On: the LED lights up.
- ▶ Off: the LED goes out.

The rearview camera image is displayed if the reverse gear is engaged when pressing the park assistance button.

WARNING

Signal tones

An intermittent tone indicates when the vehicle is approaching an object. E.g., if an object is detected to the left rear of the vehicle, a signal tone sounds from the left rear speaker.

The shorter the distance to the object, the shorter the intervals.

If the distance to a detected object is less than approx. 10 inches/25 cm, a continuous tone is sounded.

With front PDC: if objects are simultaneously located both in front of and behind the vehicle, an alternating continuous signal is sounded.

The signal tone is switched off, when selector lever position P is engaged.

Volume

The ratio of the PDC signal tone volume to the entertainment volume can be adjusted.

Via iDrive:

1. "My Vehicle"
2. "iDrive settings"
3. "Tone"



4. "Volume settings"
5. "PDC"
6. Set the desired value.

The setting is stored for the driver profile currently used.

Visual warning



The approach of the vehicle to an object is shown on the Control Display. Objects that are farther away are already displayed on the Control Display before a signal sounds.

A display appears as soon as Park Distance Control (PDC) is activated.

The range of the sensors is represented in the colors green, yellow and red.

When the image of the rearview camera is displayed, the switch can be made to PDC:

1. Move the Controller to the left, if needed.
2.  "Rear view camera"

System limits

Safety information

WARNING

The system can react not at all, too late, incorrectly, or without justification due to the system limits. There is a risk of accidents or risk of damage to property. Follow the information regarding the system limits and actively intervene if needed.

Limits of ultrasonic measurement

Ultrasonic measurements might not function in the following situations:

- ▷ For small children and animals.
- ▷ For persons with certain clothing, for instance coats.
- ▷ With external interference of the ultrasound, for instance from passing vehicles or loud machines.
- ▷ When sensors are dirty, iced over, damaged or out of position.
- ▷ Under certain weather conditions such as high relative humidity, wet conditions, snowfall, extreme heat, or strong wind.
- ▷ With tow bars and trailer couplings of other vehicles.
- ▷ With thin or wedge-shaped objects.
- ▷ With moving objects.
- ▷ With elevated, protruding objects such as ledges or cargo.
- ▷ With objects with corners and sharp edges.
- ▷ With objects with a fine surface structure such as fences.
- ▷ For objects with porous surfaces.
- ▷ If cargo protrudes.
- ▷ Low objects already displayed, for instance curbs, can move into the blind area of the sensors before or after a continuous tone sounds.

False warnings

The system may issue a warning under the following conditions even though there is no obstacle within the detection range:

- ▷ In heavy rain.
- ▷ When sensors are very dirty or covered with ice.
- ▷ When sensors are covered in snow.
- ▷ On rough road surfaces.
- ▷ On uneven surfaces, such as speed bumps.

- ▷ In large buildings with right angles and smooth walls, for instance in underground garages.
- ▷ In automatic vehicle washes.
- ▷ Due to heavy exhaust.
- ▷ Due to other ultrasound sources, for instance sweeping machines, high pressure steam cleaners or neon lights.

If necessary, switch off automatic PDC activation on obstacle detection, for instance in vehicle washes, to reduce false alarms.

Malfunction

A Check Control message is displayed.



Red symbol is displayed, and the range of the sensors is dimmed on the Control Display.

PDC has failed. Have the system checked by a dealer's service center or another qualified service center or repair shop.

Rearview camera

Concept

The rearview camera provides assistance in parking and maneuvering backwards. The area behind the vehicle is shown on the Control Display.

Safety information

WARNING

The system cannot serve as a substitute for the driver's personal judgment in assessing the traffic situation. There is a risk of an accident. Adjust driving style to traffic conditions. Watch traffic and vehicle surroundings closely and actively intervene where appropriate.

Overview

Depending on the vehicle equipment: button in the vehicle



 Park assistance button

Camera



The camera lens is located underneath the tailgate.

The image quality may be impaired by dirt. If necessary, clean the camera lens.

Switching on/off

Switching on automatically

The system is automatically switched on if selector lever position R is engaged when the drive-ready state is switched on.

Automatic deactivation during forward travel

The system switches off when a certain driving distance or speed is exceeded.



Switch the system back on, if needed.

Depending on the vehicle equipment: switching on/off manually



Press park assistance button.

- ▷ On: the LED lights up.
- ▷ Off: the LED goes out.

The parking assistance functions are shown on the Control Display.

Switching the view via iDrive

If the rearview camera view is not displayed, change the view via iDrive:

1. Move the Controller to the left, if needed.
2.  "Rear view camera"

The rearview camera image is displayed.

Display on the Control Display



Functional requirement

- ▷ The rearview camera is switched on.
- ▷ The tailgate is fully closed.
- ▷ Keep the recording range of the camera clear. Protruding cargo or carrier systems and trailers that are not connected to a trailer power socket can lead to malfunctions.

Activating assistance functions

More than one assistance function can be active at the same time.

Move the Controller to the left, if needed.

- ▷ Parking aid lines
 -  "Parking aid lines"
Lanes and turning radius are indicated.
- ▷ Obstacle marking
 -  "Obstacle marking"
Obstacles are marked, depending on the vehicle equipment.

Pathway lines

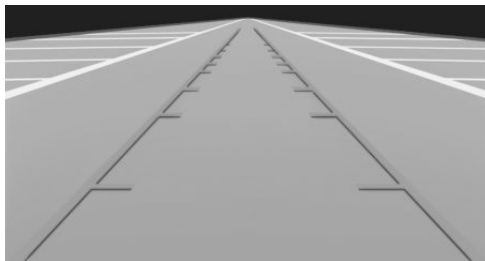

Pathway lines can be superimposed on the image of the rearview camera.

Pathway lines help you to estimate the space required when parking and maneuvering on level roads.

Pathway lines depend on the current steering angle and are continuously adjusted to the steering wheel movements.

Turning radius lines

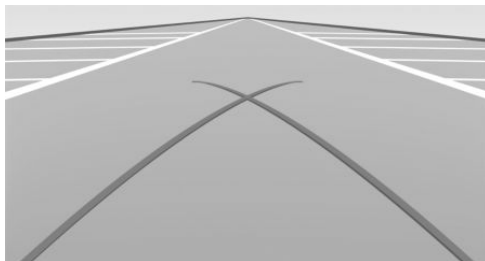

Turning radius lines can only be superimposed on the rearview camera image together with pathway lines.

Turning radius lines show the course of the smallest possible turning radius on a level road.

Only one turning radius line is displayed after the steering wheel is turned past a certain angle.

Obstacle marking

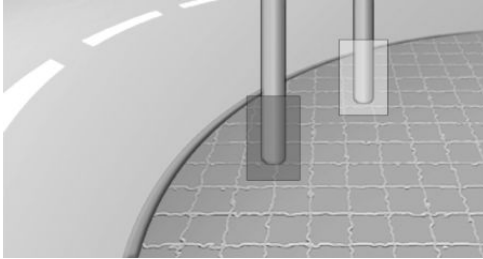

If the vehicle is equipped accordingly, obstacles behind the vehicle are detected by the PDC Park Distance Control sensors and the rearview camera.

Depending on the vehicle equipment, obstacle markings can be faded into the image of the rearview camera.

The colored thresholds of the obstacle markings match the markings of the PDC Park Distance Control.

Parking using pathway and turning radius lines

1. Position the vehicle so that the turning radius lines lead to within the limits of the parking space.

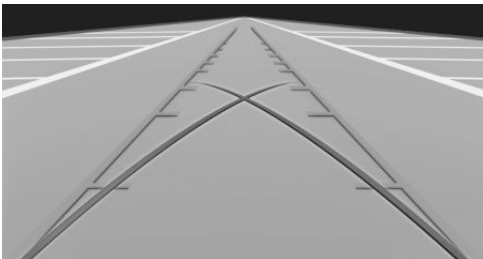

2. Turn the steering wheel to the point where the pathway line covers the corresponding turning radius line.

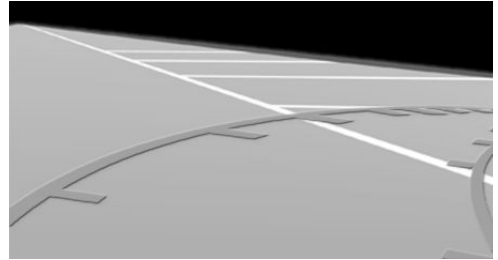

Display settings

Brightness

With the rearview camera switched on:

1. Move the Controller to the left, if needed.
2.  Select the symbol.
3. Turn the Controller until the desired setting is reached, and press the Controller.

Contrast

With the rearview camera switched on:

1. Move the Controller to the left, if needed.
2.  Select the symbol.
3. Turn the Controller until the desired setting is reached, and press the Controller.

System limits

Detection of objects

Very low obstacles as well as high, protruding objects such as ledges may not be detected by the system.

Depending on the vehicle equipment, some assistance functions also consider data from the PDC Park Distance Control.

Follow the notes in the PDC Park Distance Control chapter.



The objects displayed on the Control Display may be closer than they appear. Do not estimate the distance from the objects on the display.

Parking assistant

Concept

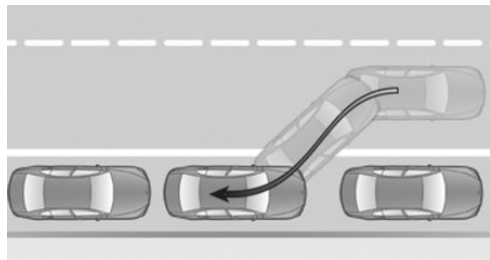

This system assists the driver in parking parallel to the road.

General information

Parking assistant handling is divided into three steps:

- ▶ Switching on and activating.
- ▶ Parking space search.
- ▶ Parking.

Ultrasound sensors measure parking spaces on both sides of the vehicle.

The parking assistant calculates the best possible parking line and during the parking procedure takes control of steering, the acceleration and braking, and if needed, changes the gears. Press and hold the park assistance button for the duration of the parking procedure.

System status and instructions on required actions are displayed on the Control Display.

The parking assistant uses the sensors of PDC Park Distance Control.

Safety information

WARNING

The system cannot serve as a substitute for the driver's personal judgment in assessing the traffic situation. Based on the limits of the system, it cannot independently react to all traffic situations. There is a risk of an accident. Adjust driving style to traffic conditions. Watch traffic closely and actively intervene where appropriate.

NOTICE

The parking assistant can steer the vehicle over or onto curbs. There is a risk of damage to property. Watch traffic closely and actively intervene where appropriate.

Also follow the safety information for PDC Park Distance Control.

Overview

Button in the vehicle



Park assistance button

Ultrasound sensors

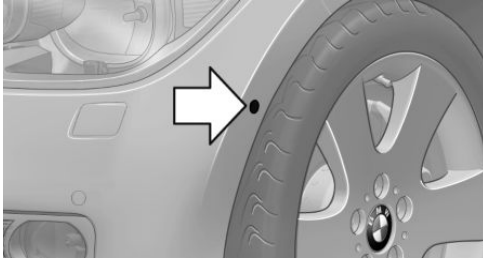

The ultrasound sensors for measuring parking spaces are located on the side of the vehicle.

Functional requirements

Ultrasound sensors

Ensure full functionality:

- ▶ Do not cover sensors, for instance with stickers.
- ▶ Keep the sensors clean and unobstructed.

For measuring parking spaces

- ▶ Maximum speed while driving forward approx. 22 mph/35 km/h.
- ▶ Maximum distance to row of parked vehicles: 5 ft/1.5 m.

Suitable parking space

- ▶ Gap between two objects with a minimum length of approx. 5 ft/1.5 m.
- ▶ Min. length of gap between two objects: your vehicle's length plus approx. 4 ft/1.2 m.
- ▶ Minimum depth: approx. 5 ft/1.5 m.

For parking

- ▶ Doors and tailgate are closed.
- ▶ The parking brake is released.
- ▶ Driver's safety belt is fastened.

Switching on and activating

Switching on with the button



- ▶ Press park assistance button.
- ▶ The LED lights up.

The current status of the parking space search is indicated on the Control Display.

- ▶  Parking assistant is activated automatically.

Switching on with reverse gear



Shift into reverse.

The current status of the parking space search is indicated on the Control Display.

- ▶ To activate:  "Parking Assistant"

Display on the Control Display

System activated/deactivated

Symbol	Meaning
	Gray: the system is not available. White: the system is available but not activated.
	The system is activated.

Parking space search and system status

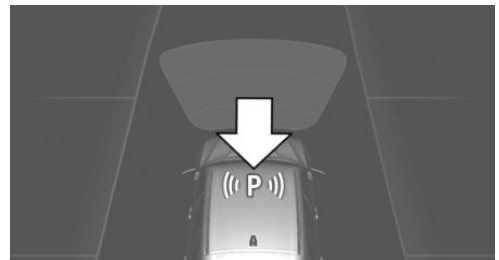

- ▶ Symbol P on the vehicle image: the parking assistant is activated and the parking space search is active.
- ▶ Control Display shows suitable parking spaces at the edge of the road next to the ve-





hicle symbol. When the parking assistant is active, suitable parking spaces are highlighted.

- ▶  The parking procedure is active. Steering control has been taken over by system.

- ▶ Parking space search is always active whenever the vehicle is moving forward slow and straight, even if the system is deactivated. When the system is deactivated, the displays on the Control Display are shown in gray.

Parking using the parking assistant

Parking

1.  Press the park assistance button or shift into reverse gear to switch on the parking assistant, refer to page 169. Activate the parking assistant, if needed.
 -  Parking assistant is activated.
2. Pass the row of parked vehicles at a speed of up to approx. 22 mph/35 km/h and at a distance of maximum 5 ft/1.5 m.



The status of the parking space search and possible parking spaces are displayed on the Control Display, refer to page 169.
3. Follow the instructions on the Control Display.

Press and hold the park assistance button for the duration of the parking procedure. At the end of the parking procedure, the P selector lever position is set.

The end of the parking procedure is indicated on the Control Display.
4. Adjust the parking position yourself, if needed.

Interrupting manually

The parking assistant can be interrupted at any time:

- ▶  Press park assistance button.
- ▶  "Parking Assistant" Select the symbol on the Control Display.

Interrupting automatically

The system is interrupted automatically in the following situations:

- ▶ If the driver grasps the steering wheel or takes over steering.
 - ▶ Possibly on snow-covered or slippery road surfaces.
 - ▶ When there are obstacles that are hard to overcome, such as curbs.
 - ▶ When there are obstacles that suddenly appear.
 - ▶ If the PDC Park Distance Control displays clearances that are too small.
 - ▶ If a maximum number of parking attempts or the time taken for parking is exceeded.
 - ▶ When switching to another function on the Control Display.
 - ▶ When the park assistance button is released.
 - ▶ If the tailgate is open.
 - ▶ If doors are open.
 - ▶ When setting the parking brake.
 - ▶ During acceleration.
 - ▶ When braking.
 - ▶ When unfastening the driver's safety belt.
- A Check Control message is displayed.

Resuming

An interrupted parking procedure can be continued, if needed.

Reactivate the parking assistant, refer to page 169, and follow the instructions on the Control Display.

Switching off

The system can be switched off as follows:

- ▶  Press park assistance button.

System limits

Safety information

WARNING

The system can react not at all, too late, incorrectly, or without justification due to the system limits. There is a risk of accidents or risk of damage to property. Follow the information regarding the system limits and actively intervene if needed.

No parking assistance

The parking assistant does not offer assistance in the following situations:

- ▶ In tight curves.

Functional limitations

The system may not be fully functional in the following situations:

- ▶ On bumpy road surfaces such as gravel roads.
- ▶ On slippery ground.
- ▶ On steep uphill or downhill grades.
- ▶ With accumulations of leaves/snow in the parking space.
- ▶ With ditches or edges, for instance an edge of a port.

Limits of ultrasonic measurement

Ultrasonic measurements might not function in the following situations:

- ▶ For small children and animals.
- ▶ For persons with certain clothing, for instance coats.
- ▶ With external interference of the ultrasound, for instance from passing vehicles or loud machines.

- ▶ When sensors are dirty, iced over, damaged or out of position.
- ▶ Under certain weather conditions such as high relative humidity, wet conditions, snowfall, extreme heat, or strong wind.
- ▶ With tow bars and trailer couplings of other vehicles.
- ▶ With thin or wedge-shaped objects.
- ▶ With moving objects.
- ▶ With elevated, protruding objects such as ledges or cargo.
- ▶ With objects with corners and sharp edges.
- ▶ With objects with a fine surface structure such as fences.
- ▶ For objects with porous surfaces.
- ▶ If cargo protrudes.
- ▶ Low objects already displayed, for instance curbs, can move into the blind area of the sensors before or after a continuous tone sounds.

Parking spaces that are not suitable may be detected or suitable parking spaces may not be detected at all.

Malfunction

A Check Control message is displayed.

The parking assistant failed. Have the system checked by a dealer's service center or another qualified service center or repair shop.



Climate control

Vehicle features and options

This chapter describes all standard, country-specific and optional features offered with the series. It also describes features that are not necessarily available in your vehicle, e. g., due to the selected options or country versions. This also applies to safety-related functions and systems. When using these functions and systems, the applicable laws and regulations must be observed.

Interior air quality

The air quality inside the vehicle is improved by an emissions-tested interior, a microfilter, and a climate-control system for regulating temperature, air flow, and recirculated-air mode.

In addition there are other functions which depend on the vehicle's equipment, for instance microfilter/activated-charcoal filter, automatic climate control with automatic recirculated-air control AUC, and parked-car ventilation.

Air conditioner



1 Seat heating, left [90](#)

2 Air conditioning

3 Temperature

4 Air distribution, windows

5 Air distribution, upper body region

6 Air distribution, floor area

7 Remove ice and condensation

8 Rear window defroster

9 Recirculated-air mode

10 Seat heating, right [90](#)

11 Air flow

Climate control functions in detail

Switching the system on/off

Switching on

Press any button except for the following:

- ▷ Rear window defroster.
- ▷ Seat heating.

Switching off



Press and hold the left button until the control switches off.

Temperature

Concept

The system heats or cools, depending on the set temperature.

Settings



Turn the ring to set the desired temperature.

To reduce the energy consumption, the cooling or heating output is reduced or deactivated as per

ECO-PRO mode, refer to page [205](#).

Air conditioning

Concept

The air in the car's interior will be cooled and dehumidified and, depending on the temperature setting, warmed again.

Cooling of the car's interior with the A/C button is only possible with drive-ready state switched on.

Switching on/off



Press button.

The LED is illuminated with air conditioning switched on.

Depending on the weather, the windshield and side windows may fog up briefly when drive-ready state is activated.

The air conditioner produces condensation water, refer to page [201](#), that will exit from below the vehicle.

Recirculated-air mode

Concept

You may react to unpleasant odors or pollutants in the immediate environment by temporarily suspending the supply of outside air. The system then recirculates the air flow within the vehicle.

Operation



Press button repeatedly to select an operating mode:

- ▷ LED off: outside air flows in continuously.
- ▷ LED on, recirculated-air mode: the supply of outside air into the vehicle is permanently blocked.

To prevent window fogging, recirculated-air mode switches off automatically after a certain amount of time, depending on the environmental conditions.

With constant recirculated-air mode, the air quality in the car's interior deteriorates and the fogging of the windows increases.

If the windows fog over, switch off recirculated-air mode and increase the air flow, if needed.

Controlling the air flow manually

Concept

The air flow for climate control can be adjusted manually.



Operation



Press the left or right side of the button: decrease or increase air flow.

The intensity is indicated by LEDs. The highest level is active when five LEDs are lit.

The air flow from the air conditioner may be reduced automatically to save battery power.

Controlling the air distribution manually

Concept

The air distribution for climate control can be adjusted manually.

Operation

Press buttons repeatedly to select a program:

▷  Windows.

▷  Upper body region.

▷  Floor area.

You may combine these programs as needed.

Defrosting windows and removing condensation

Concept

Ice and condensation are quickly removed from the windshield and the front side windows.

Switching on/off



Press button.

The LED is illuminated with the system switched on.

The air flow can be adjusted with the air flow active.

If the windows are fogged over, you can also switch on the air conditioning to dehumidify the air.

Rear window defroster



Press button. The LED lights up.

The rear window defroster switches off automatically after a certain period of time.

Microfilter

In external and recirculated-air mode the microfilter filters dust and pollen from the air.

Have this filter changed during vehicle maintenance, refer to page [249](#).

Automatic climate control

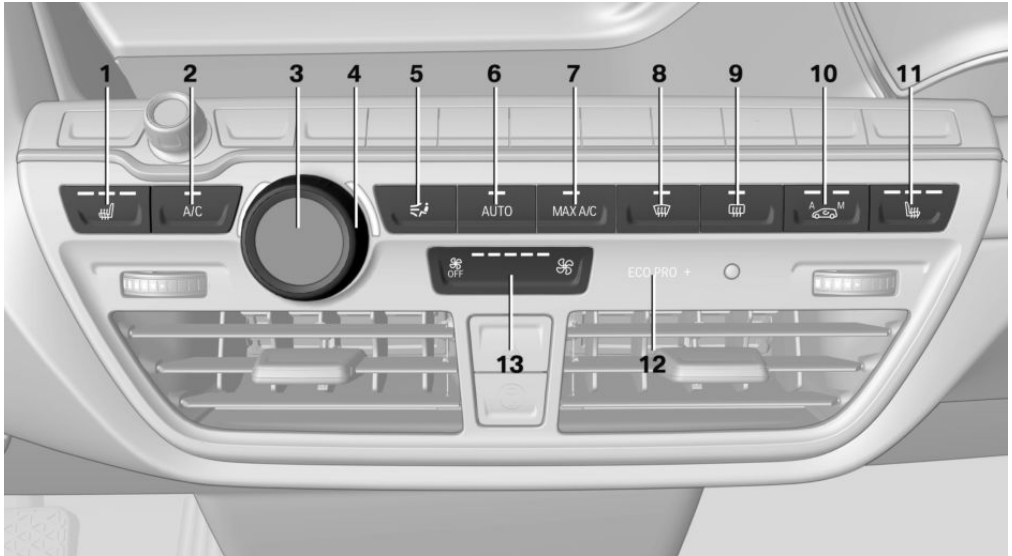

- | | |
|--|--|
| <ul style="list-style-type: none"> 1 Seat heating, left 90 2 Air conditioning 3 Display 4 Temperature 5 Air distribution settings 6 AUTO program 7 Maximum cooling | <ul style="list-style-type: none"> 8 Remove ice and condensation 9 Rear window defroster 10 Automatic recirculated-air control/recirculated-air mode 11 Seat heating, right 90 12 Activated driving mode display 205 13 Air flow, AUTO intensity |
|--|--|

Climate control functions in detail

Switching the system on/off

Switching on

Press any button except for the following:

- ▶ Rear window defroster.
- ▶ Seat heating.

Switching off



Press and hold the left button until the control switches off.

Temperature

Concept

The automatic climate control achieves the set temperature as quickly as possible, if necessary by using the maximum cooling or heating power, and then keeps it constant.

Settings



Turn the ring to set the desired temperature.



The selected temperature is shown on the display of the automatic climate control.

The automatic climate control reaches this temperature as quickly as possible, if needed, by increasing the cooling or heating output, and then keeps it constant.

Do not rapidly switch between different temperature settings. Otherwise, the automatic climate control will not have sufficient time to adjust the set temperature.

To reduce the energy consumption, the cooling or heating output is reduced or deactivated as per ECO-PRO mode, refer to page 205.

Air conditioning

Concept

The air in the car's interior will be cooled and dehumidified and, depending on the temperature setting, warmed again.

The car's interior can be cooled with the stationary climate control or via the A/C button with drive-ready state activated.

Switching on/off

 Press button.

The LED is illuminated with air conditioning switched on.

Depending on the weather, the windshield and side windows may fog up briefly when drive-ready state is activated.

The air conditioning is switched on automatically with the AUTO program.

When using the automatic climate control, condensation water, refer to page 201, develops and drains underneath the vehicle. This is normal.

Maximum cooling

Concept

The system is set to the lowest temperature, optimum air flow and recirculated-air mode.

General information

The function is available above an external temperature of approximately 32 °F/0 °C or the drive-ready state is available.

Switching on/off

 Press button.

The LED is illuminated with the system switched on.

Air flows out of the vents to the upper body region. The vents need to be open for this.

If ECO PRO+, refer to page 205, is activated, this function is deactivated.

The air flow can be adjusted with the air flow active.

AUTO program

Concept

Air flow, air distribution and temperature are controlled automatically.

Switching on/off

 Press button.

The LED is illuminated with the AUTO program switched on.

Depending on the selected temperature, the intensity of the AUTO program, and outside influences, the air is directed to the windshield, side windows, upper body, and into the floor area.

The air conditioning, refer to page 176, is switched on automatically with the AUTO program.

At the same time, a condensation sensor controls the program so as to prevent window condensation as much as possible.

To switch off the program: press the button again or manually adjust the air distribution.

Intensity

With the AUTO program switched on, the intensity can be set. This changes the automatic control for the air flow and air distribution.



Press the left or right side of the button: decrease or increase intensity.

The intensity level is indicated by LEDs.

Automatic recirculated-air control/ recirculated-air mode

Concept

The automatic recirculated-air control AUC recognizes odors or pollutants in the outside air. The outside air supply is shut off and the interior air is recirculated.

General information

If the system is activated, a sensor detects pollutants in the outside air and controls the shut-off automatically.

If the system is deactivated, outside air continuously flows into the car's interior.

With constant recirculated-air mode, the air quality in the car's interior deteriorates and the fogging of the windows increases.

Switching on/off



Press button repeatedly to select an operating mode:

- ▶ LEDs off: outside air flows in continuously.
- ▶ Left LED on, automatic recirculated-air control: a sensor detects pollutants in the outside air and shuts off automatically.
- ▶ Right LED on, recirculated-air mode: the supply of outside air into the vehicle is permanently blocked.

To prevent window fogging, recirculated-air mode switches off automatically after a certain amount of time, depending on the environmental conditions.

If the windows are fogged over, switch off the recirculated-air mode and press the AUTO button to utilize the condensation sensor. Make sure that air can flow to the windshield.

Controlling the air flow manually

Concept

The air flow for climate control can be adjusted manually.

General information

To manually adjust air flow switch off AUTO program first.

Operation



Press the left or right side of the button: decrease or increase air flow.

The intensity is indicated by LEDs. The highest level is active when five LEDs are lit.

The air flow of the automatic climate control may be reduced automatically to save battery power.

Controlling the air distribution manually

Concept

The air distribution for climate control can be adjusted manually.

Operation



Press button repeatedly to select a program:

- ▶ Windows.
- ▶ Upper body region.
- ▶ Floor area.
- ▶ Windows and upper body region.
- ▶ Windows and floor area.
- ▶ Upper body region and floor area.
- ▶ Windows, upper body region, and floor area.

The selected air distribution is shown on the display of the automatic climate control.



If the windows are fogged over, press the AUTO button to utilize the condensation sensor.

Defrosting windows and removing condensation

Concept

Ice and condensation are quickly removed from the windshield and the front side windows.

Switching on/off



Press button.

The LED is illuminated with the system switched on.

For this purpose, point the side vents towards the side windows as needed.

The air flow can be adjusted with the air flow active.

If the windows are fogged over, you can also switch on the air conditioning or press the AUTO button to utilize the condensation sensor.

Rear window defroster



Press button. The LED lights up.

The rear window defroster switches off automatically after a certain period of time.

Microfilter/activated-charcoal filter

In external and recirculated-air mode the microfilter/activated charcoal filter filters dust, pollen, and gaseous pollutants out of the air.

Have this filter changed during vehicle maintenance, refer to page [249](#).

Ventilation

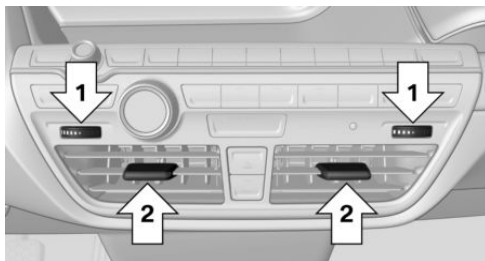

- ▷ Thumbwheels for opening and closing the vents continuously, arrows 1.
- ▷ Lever for changing the air flow direction, arrow 2.

Adjusting the ventilation

- ▷ Ventilation for cooling:
 - Direct vent in your direction when car's interior is too hot.
- ▷ Draft-free ventilation:
 - Adjust the vent to let the air flow past you.

Stationary climate control

Concept

Stationary climate control cools or heats the car's interior prior to departure to a comfortable temperature.

The interior temperature is lowered with high cooling output.

The system may heat the car's interior. Snow and ice can be removed more easily.

General information

The stationary climate control can be switched on and off directly or via a pre-set departure time.

- ▷ Direct operation, refer to page [179](#).
- ▷ Preselected departure times, refer to page [179](#).

With the BMW Connected app, refer to page 180, the stationary climate control can be switched on.

The air automatically exits through the vents to the windshield, the side windows, the upper body region and into the floor area.

The system switches off automatically after a certain period of time.

If stationary climate control is used during the charging process, less air conditioning capacity will be required while driving. This optimizes the range.

Functional requirements

- ▶ Drive-ready state is deactivated.
- ▶ High-voltage battery sufficiently charged or charging cable connected.

If the high-voltage battery is heavily discharged, it can take some time after connecting the charging cable, until the stationary climate control will be functional.

- ▶ Departure time preselected: depends on the internal, external, and set desired temperature.
- ▶ Direct operation via iDrive: does not depend on the external temperature.
- ▶ The vents are open to allow air to flow out.

Switching on/off directly

Concept

The system can be switched on or off directly.

The system switches off automatically after a certain period of time.

Via iDrive

The system can be switched on or off via iDrive.

1. "My Vehicle"
2. "Vehicle settings"
3. If necessary, "Climate functions"

4. "Activate comfort climate"
5. "Activate now"

Climate control at departure time

Concept

Different departure times can be adjusted to ensure a comfortable interior temperature in the vehicle at the time of departure.

The activation time is automatically determined based on the temperature.

The system promptly switches on before the selected departure time.

The departure time is preselected in two steps:

- ▶ Set departure times.
- ▶ Activate departure times.

General information

If drive-ready state is switched off, changes can be made on the Control Display. Departure time can only be changed once. Scheduled departure times are not adjusted. Settings for climate control and charging process are also applied for scheduled departure times.

Setting departure times

Via iDrive

1. "My Vehicle"
2. "Vehicle settings"
3. If necessary, "Climate functions"
4. "Activate comfort climate"
5. "Plan comfort climate"
6. Set the desired departure time, refer to page 219.

Activating the departure time

Functional requirement

If a departure time is to influence the switching on of the stationary climate control, the respective departure time must be activated first.





Via iDrive

1. "My Vehicle"
2. "Vehicle settings"
3. If necessary, "Climate functions"
4. "Activate comfort climate"
5. "Plan comfort climate"
6. "Precondition for departure"

Activate the desired departure time.

Display

 The symbol on the automatic climate control lights up when the departure time is activated.

 The symbol on the automatic climate control flashes when the stationary climate control has been switched on.

Activating with the BMW Connected app

Using an appropriate BMW Connected app with remote function, the system can be switched on directly or via a preset departure time.

Interior equipment

Vehicle features and options

This chapter describes all standard, country-specific and optional features offered with the series. It also describes features that are not necessarily available in your vehicle, e. g., due to the selected options or country versions. This also applies to safety-related functions and systems. When using these functions and systems, the applicable laws and regulations must be observed.

Integrated Universal Remote Control

Concept

The integrated Universal Remote Control in the interior mirror can operate up to 3 functions of remote-controlled systems, such as garage door drives, barriers, or lighting systems. The Integrated Universal Remote Control replaces up to 3 different hand-held transmitters. To operate the remote control, the buttons on the interior mirror must be programmed with the desired functions. The hand-held transmitter for the particular system is required in order to program the remote control.

Before selling the vehicle, delete the stored functions for the sake of security.

Safety information

WARNING

Body parts can be jammed when operating remote-controlled systems, such as the garage door, using the integrated Universal Remote Control. There is a risk of injury or risk of damage to property. Make sure that the area of movement of the respective system is clear during programming and operation. Also follow

the safety information of the hand-held transmitter.

Compatibility



If this symbol is printed on the packaging or in the owner's manual of the system to be controlled, the system is generally compatible with the integrated Universal Remote Control.

If you have any questions, please contact:

- ▷ A dealer's service center or another qualified service center or repair shop.
- ▷ www.homelink.com on the Internet.

HomeLink is a registered trademark of Gentex Corporation.

Control elements on the interior mirror

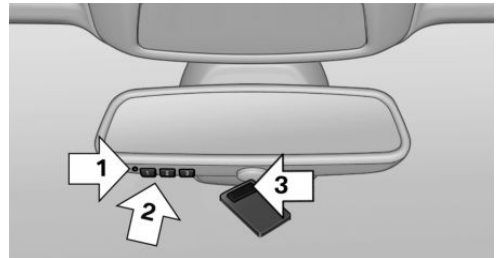

- ▷ LED, arrow 1.
- ▷ Buttons, arrow 2.
- ▷ The hand-held transmitter, arrow 3, is required for programming.

Programming

General information

1. Switch on the ignition.
2. Initial setup:



Press and hold the two outer buttons on the interior mirror simultaneously for approximately 20 seconds until the LED on the interior mirror flashes. This erases all programming of the buttons on the interior mirror.

3. Hold the hand-held transmitter for the system to be controlled approx. 1 to 3 inches/2.5 to 8 cm away from the buttons of the interior mirror. The required distance depends on the hand-held transmitter.
4. Simultaneously press and hold the button of the desired function on the hand-held transmitter and the button to be programmed on the interior mirror. The LED on the interior mirror will begin flashing slowly.
5. Release both buttons as soon as the LED flashes more rapidly. The LED flashing faster indicates that the button on the interior mirror has been programmed.

If the LED does not flash faster after at least 60 seconds, change the distance between the interior mirror and the hand-held transmitter and repeat the step. Several more attempts at different distances may be necessary. Wait at least 15 seconds between attempts.

Canada: if programming with the hand-held transmitter was interrupted, hold down the interior mirror button and repeatedly press and release the hand-held transmitter button for 2 seconds.

6. To program other functions on other buttons, repeat steps 3 to 5.

The systems can be controlled using the interior mirror buttons.

Special feature of the rolling code wireless system

If you are unable to operate the system after repeated programming, please check if the system to be controlled features a rolling code radio system.

Read the system's owner's manual, or press the programmed button on the interior mirror longer.

If the LED on the interior mirror starts flashing rapidly and then stays lit constantly for 2 seconds, the system features a rolling code radio system. Flashing and continuous illumination of the LED will repeat for approximately 20 seconds.

For systems with a rolling code radio system, the integrated Universal Remote Control and the system also have to be synchronized.

Please read the owner's manual to find out how to synchronize the system.

Synchronizing is easier with the aid of a second person.

Synchronizing the universal remote control with the system:

1. Park the vehicle within range of the remote-controlled system.
2. Program the desired button on the interior mirror as described.
3. Locate and press the synchronizing button on the system being programmed. You have approx. 30 seconds for the next step.
4. Hold down the programmed button on the interior mirror for approximately 3 seconds and then release it. If necessary, repeat this step up to three times in order to finish synchronization. Once synchronization is complete, the programmed function will be carried out.

Reprogramming individual buttons

1. Switch on the ignition.
2. Press and hold the interior mirror button to be programmed.
3. As soon as the interior mirror LED starts flashing slowly, hold the hand-held transmitter for the system to be controlled approx. 1 to 3 inches/2.5 to 8 cm away from the buttons of the interior mirror. The required distance depends on the hand-held transmitter.

4. Likewise, press and hold the button of the desired function on the hand-held transmitter.
5. Release both buttons as soon as the interior mirror LED flashes more rapidly. The LED flashing faster indicates that the button on the interior mirror has been programmed. The system can then be controlled by the button on the interior mirror.

If the LED does not flash faster after at most 60 seconds, change the distance and repeat the programming starting with step 4. Several more attempts at different distances may be necessary. Wait at least 15 seconds between attempts.

Canada: if programming with the hand-held transmitter was interrupted, hold down the interior mirror button and repeatedly press and release the hand-held transmitter button for 2 seconds.

Operation

WARNING

Body parts can be jammed when operating remote-controlled systems, such as the garage door, using the integrated Universal Remote Control. There is a risk of injury or risk of damage to property. Make sure that the area of movement of the respective system is clear during programming and operation. Also follow the safety information of the hand-held transmitter.

The system, such as the garage door, can be operated using the button on the interior mirror while the engine is running or when the ignition is started. To do this, hold down the button within receiving range of the system until the function is activated. The interior mirror LED stays lit while the wireless signal is being transmitted.

Deleting stored functions

All stored functions will be deleted. The functions cannot be deleted individually. Press and hold the two outer buttons on the interior mirror simultaneously for approximately 20 seconds until the LED on the interior mirror flashes rapidly.

Digital compass

Overview

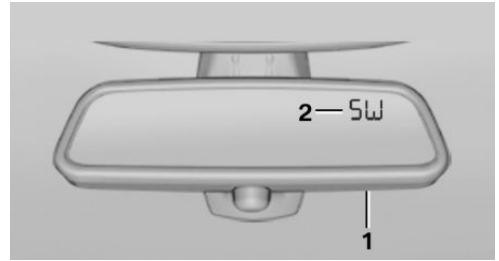

- 1 Control button
- 2 Mirror display

Mirror display

The point of the compass is displayed in the mirror when driving straight.

Operating concept

Various functions can be called up by pressing the control button with a pointed object, such as the tip of a ballpoint pen or similar object. The following setting options are displayed in succession, depending on how long the control button is pressed:

- ▷ Pressed briefly: turns display on/off.
- ▷ 3 to 6 seconds: compass zone setting.
- ▷ 6 to 9 seconds: compass calibration.
- ▷ 9 to 12 seconds: left/right-hand steering setting.
- ▷ 12 to 15 seconds: language setting.



Setting the compass zones

Sets the particular compass zones on the vehicle so that the compass operates correctly; refer to World map with compass zones.

World map with magnetic zones

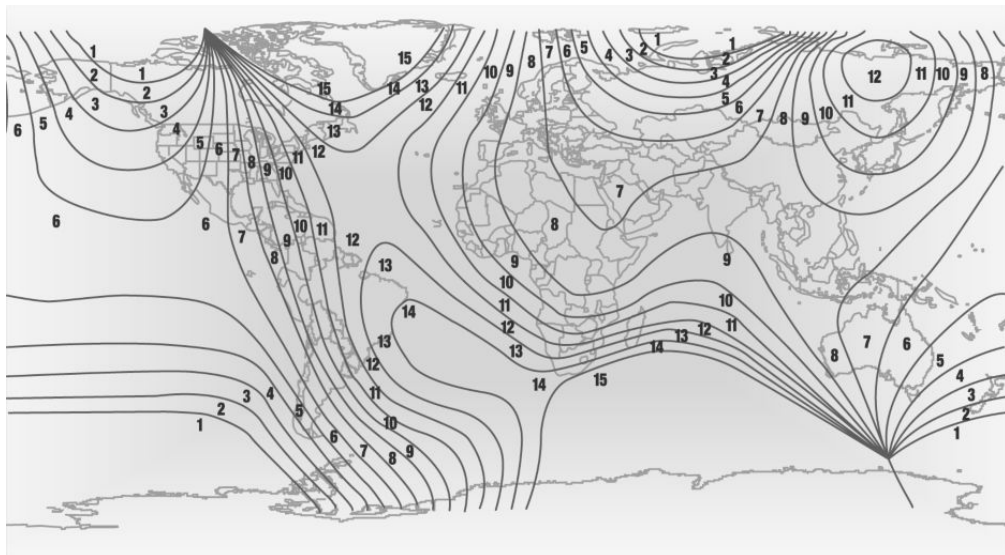

Procedure

1. Press and hold the control button for approx. 3 to 4 seconds. The number of the set compass zone appears in the mirror.
2. To change the zone setting, press the control button quickly and repeatedly until the number of the compass zone that corresponds with your location appears in the mirror.

The set zone is stored automatically. The compass is ready for use again after approximately 10 seconds.

Calibrating the digital compass

The digital compass must be calibrated in the event of the following:

- ▷ The wrong compass point is displayed.

- ▷ The point of the compass displayed does not change despite changing the direction of travel.
- ▷ Not all points of the compass are displayed.

Procedure

1. Make sure that there are no large metallic objects or overhead power lines near the vehicle and that there is sufficient room to drive around in a circle.
2. Set the currently applicable compass zone.
3. Press and hold the control button for approx. 6 to 7 seconds so that "C" appears on the display. Next, drive in a complete circle at least once at a speed of no more than 4 mph/7 km/h. If calibration is successful, the "C" is replaced by the points of the compass.

Left/right-hand steering

The digital compass is already set for right or left-hand steering at the factory.

Setting the language

Press and hold the control button for approx. 12 to 13 seconds. Briefly press the control button again to switch between English "E" and German "O".

Settings are stored automatically after approximately 10 seconds.

Sun visor

Glare shield

Fold the sun visor down or up.

Vanity mirror

A vanity mirror is located in the sun visor behind a cover. Depending on the equipment version, the mirror lighting may switch on when the cover is opened.

Ashtray/cigarette lighter

Ashtray

Overview



The ashtray can be inserted in the cup holder.

Emptying

Take out the insert.

Cigarette lighter

WARNING

Contact with the hot heating element or the hot socket of the cigarette lighter can cause burns. Flammable materials can ignite if the cigarette lighter falls down or is held against the respective objects. There is a risk of fire and injuries. Take hold of the cigarette lighter by its handle. Make sure that children do not use the cigarette lighter and burn themselves.

NOTE

If metal objects fall into the socket, they can cause a short circuit. There is a risk of damage to property. Replace the cigarette lighter or socket cover again after using the socket.

Overview

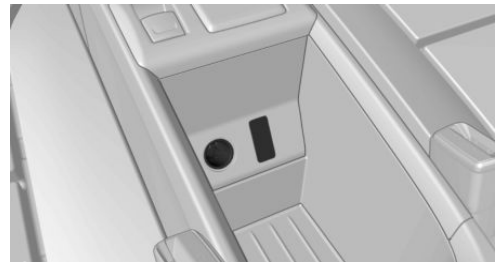

The cigarette lighter is located between the front seats.



Push in the cigarette lighter.

The cigarette lighter can be removed as soon as it pops back out.



Sockets

General information

The lighter socket can be used as a socket for electrical equipment when standby and drive-ready state are switched on.

The total load of all sockets must not exceed 140 watts at 12 volts.

Do not damage the socket by using non-compatible connectors.

Safety information

WARNING

Devices and cables in the unfolding area of the airbags, such as portable navigation devices, can hinder the unfolding of the airbag or be thrown around in the car's interior during unfolding. There is a risk of injury. Make sure that devices and cables are not in the airbag's area of unfolding.

NOTE

Battery chargers for the vehicle battery can work with high voltages and currents, which means that the 12 volt on-board network can be overloaded or damaged. There is a risk of damage to property. Only connect battery chargers for the vehicle battery to the starting aid terminals in the engine compartment.

NOTE

If metal objects fall into the socket, they can cause a short circuit. There is a risk of damage to property. Replace the cigarette lighter or socket cover again after using the socket.

Front center console



The socket is located underneath the dashboard. Remove the cover.

Between the front seats

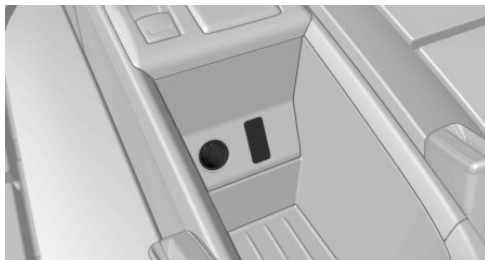

The socket is located between the front seats. Remove the cover or cigarette lighter.

In the cargo area



The socket is located on the right side in the cargo area. Remove the cover.

USB interface

Concept

Mobile devices with USB port can be connected to the USB interface.

General information

Follow the information regarding the connection of mobile devices to the USB interface in the section on USB connections, refer to page 54.

Overview

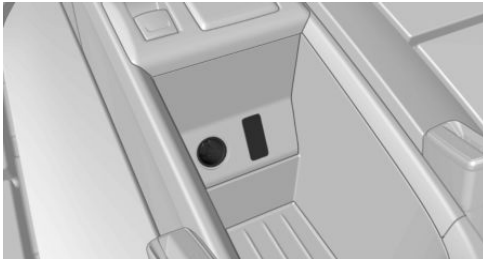

The USB interface is located between the front seats.

Connecting an external device

Follow the following when connecting:

- ▶ Do not use force when plugging the connector into the USB interface.
- ▶ Use a flexible adapter cable.
- ▶ Protect the USB storage device against mechanical damage.
- ▶ Due to the large number of USB media available on the market, it cannot be guaranteed that every device is operable on the vehicle.
- ▶ Do not expose USB media to extreme environmental conditions, such as very high temperatures; refer to the owner's manual of the device.
- ▶ Due to the many different compression techniques, proper playback of the media stored

on the USB storage device cannot be guaranteed in all cases.

- ▶ A connected USB storage device will be supplied with charging current via the USB interface if the device supports this. At higher temperatures, the USB storage device may cause a reduction in the charging current.
- ▶ To ensure proper transmission of the stored data, do not charge a USB storage device via the onboard socket, when it is connected to the USB interface.
- ▶ Depending on how the USB storage device is being used, settings may be required on the USB storage device, refer to the owner's manual of the device.

Non-compatible USB media:

- ▶ USB hard drives.
- ▶ USB hubs.
- ▶ USB memory card readers with multiple inserts.
- ▶ HFS-formatted USB media.
- ▶ Devices such as fans or lamps.

Cargo area

Cargo cover

General information

The cargo cover is raised when the tailgate is opened.

Safety information

WARNING

Loose objects or devices with a cable connection to the vehicle, for instance mobile phones, can be thrown into the car's interior while driving, for instance in the event of an accident or during braking and evasive maneuvers. There is a risk of injury. Secure loose objects or devices



with a cable connection to the vehicle in the car's interior.

Removing

1. Detach the retaining straps at the tailgate.
2. Raise the cover and pull it back to remove.



Installing

1. Place the cover in the brackets.
2. Attach the retaining straps.

Enlarging the cargo area

Concept

The cargo area can be enlarged by folding down the rear seat backrest or moving it into the cargo position.

General information

The rear seat backrest is divided at a ratio of 50 to 50.

The rear seat backrests can be folded down from the rear or from the cargo area.

Safety information

WARNING

Danger of jamming with folding down the backrests. There is a risk of injury or risk of damage to property. Make sure that the area of movement of the rear backrest and the of the head restraint is clear prior to folding down.

WARNING

If a rear seat backrest is not locked, unsecured cargo can be thrown into the car's interior; for instance, in the event of an accident, braking or an evasive maneuver. There is a risk of injury. Make sure that the rear seat backrest is locked after folding it back.

WARNING

Unexpected movements of the backrest while driving may occur due to unintentional unlocking of the rear backrests by the straps. There is a risk of injury. Do not fasten any objects to the straps for unlocking the rear backrests.

WARNING

The stability of the child restraint system is limited or compromised with incorrect seat adjustment or improper installation of the child seat. There is a risk of injuries or danger to life. Make sure that the child restraint system fits securely against the backrest. If possible, adjust the backrest tilt for all affected backrests and correctly adjust the seats. Make sure that seats and backrests are securely engaged or locked. If possible, adjust the height of the head restraints or remove them.

NOTE

Vehicle parts can be damaged when folding down the rear backrest. There is a risk of damage to property. Make sure that the area of movement of the rear backrest including head restraint is clear when folding down.

Folding down the rear seat backrest from the rear

1. Insert the safety belt into the buckle.

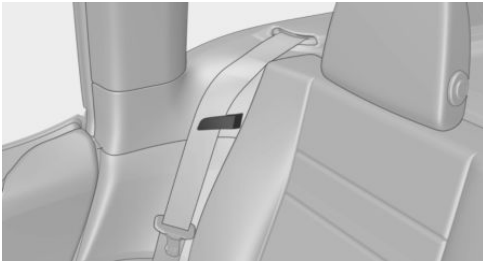

2. Pull the strap forward.

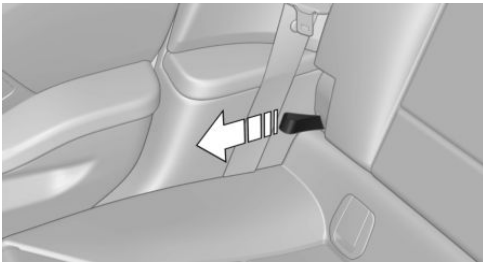

3. Fold the rear seat backrest forward.

Folding down the rear seat backrest from the cargo area

1. Pull corresponding strap.

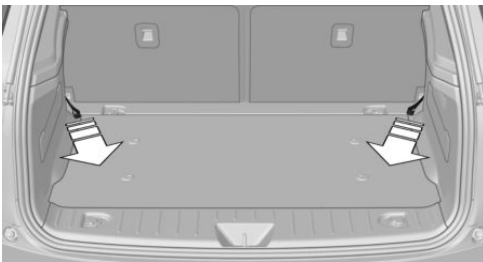

2. Fold the rear seat backrest forward.

Cargo position

Concept

The rear seat backrests can be separately moved through two different stages into an up-right loading position.

Settings

1. Pull the strap.

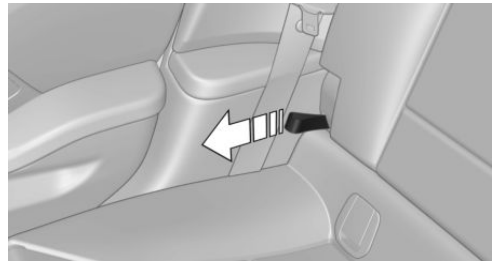

2. Set the loading position of the rear seat backrest as required.
3. Latch the rear seat backrest. The red mark on the front strap disappears.

Fold back the backrest

1. Insert the safety belt into the buckle.

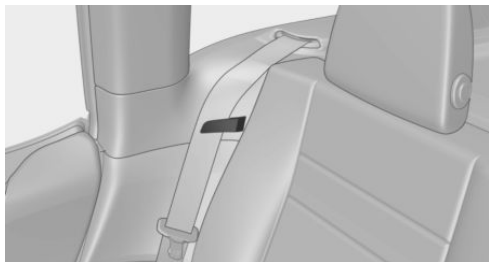

2. Pull the strap.

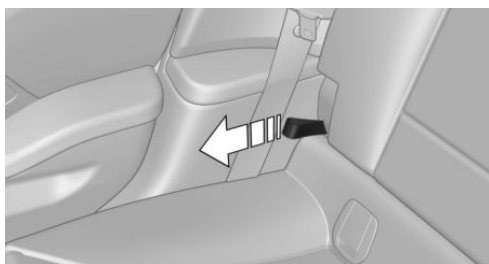

3. Fold the rear seat backrest rearward. The rear seat backrest first engages in the loading position.
4. Pull the strap again.
5. Fold rear seat backrest all the way back.
6. Latch the rear seat backrest. The red mark on the front strap disappears.



Storage compartments

Vehicle features and options

This chapter describes all standard, country-specific and optional features offered with the series. It also describes features that are not necessarily available in your vehicle, e. g., due to the selected options or country versions. This also applies to safety-related functions and systems. When using these functions and systems, the applicable laws and regulations must be observed.

- ▶ Glove compartment on the front passenger side, refer to page 191.
- ▶ Trays between the front seats, refer to page 192.
- ▶ Compartments in the front doors, refer to page 193.
- ▶ Clothes hooks, refer to page 194.
- ▶ Rear seat, refer to page 193.
- ▶ Storage compartments in the cargo area, refer to page 194.

Safety information

WARNING

Loose objects or devices with a cable connection to the vehicle, for instance mobile phones, can be thrown into the car's interior while driving, for instance in the event of an accident or during braking and evasive maneuvers. There is a risk of injury. Secure loose objects or devices with a cable connection to the vehicle in the car's interior.

NOTE

Anti-slip pads such as anti-slip mats can damage the dashboard. There is a risk of damage to property. Do not use anti-slip pads.

Storage compartments

The following storage compartments are available in the car's interior:

- ▶ Retaining strap at the front of the floor area between the driver's seat and the front passenger seat, refer to page 193.

Glove compartment

Front passenger side

Safety information

WARNING

Folded open, the glove compartment protrudes in the car's interior. Objects in the glove compartment can be thrown into the car's interior while driving, for instance in the event of an accident or during braking and evasive maneuvers. There is a risk of injury. Always close the glove compartment immediately after using it.

Opening

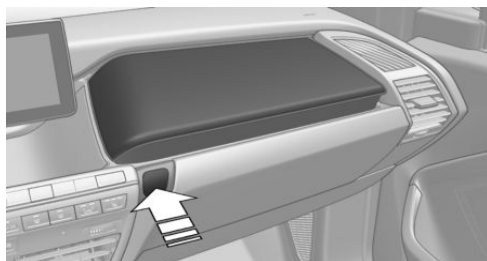

Press the button.



Closing

Fold cover closed.

Locking

The glove compartment can be locked with an integrated key. This prevents access to the glove compartment.

After the glove compartment is locked, the remote control can be handed over, such as at a hotel, without the integrated key.

Between the front seats

Center armrest

Open/tilt

A storage compartment is located in the center armrest between the seats.

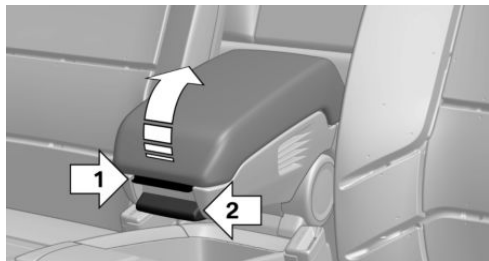

To open, press button, arrow 1.

To open, press button, arrow 2.

Front cup holder

Safety information

WARNING

Unsuitable containers in the cup holder and hot beverages can damage the cup holder and increase the risk of injury in the event of an accident. There is a risk of injury or risk of damage to property. Use light-weight, unbreakable, and

sealable containers. Do not transport hot beverages. Do not force objects into the cup holder.

Overview

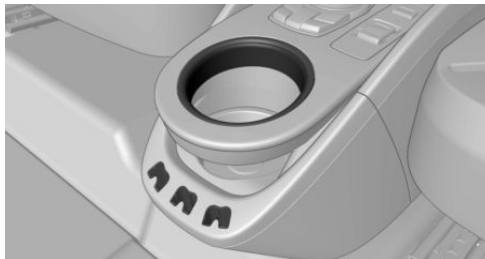

Between the seats.

Receptacle for cup holder

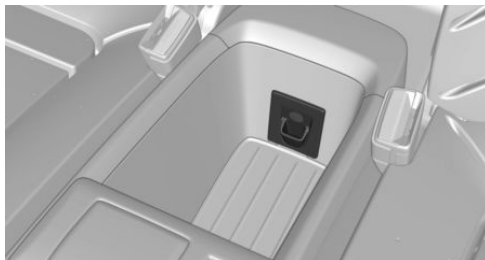

There is a receptacle for the cup holder between the seats.



There are three receptacles for the cup holder between the seats.



Inserting a cup holder

Insert a cup holder into the receptacle for the cup holder in the storage compartment or into one of the front receptacles.

Removing a cup holder

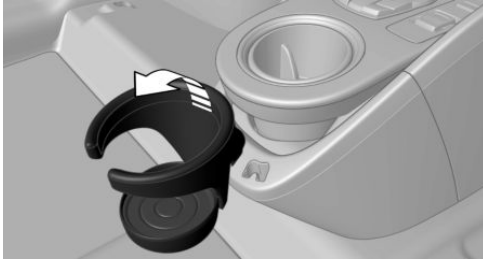

Tilt the cup holder forward slightly, pulling it up at the same time.

Storage compartment

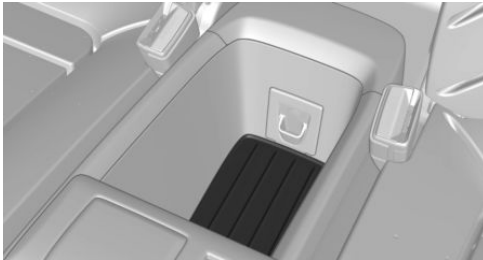

There is a storage compartment between the seats.

Retaining strap

In the floor area between the driver's seat and the front passenger seat, there is a retaining strap for fastening smaller objects.

Compartments in the doors

WARNING

Breakable objects, such as glass bottles or glasses, can break in the event of an accident or a braking or evasive maneuver. Broken glass can be scattered in the car's interior. There is a risk of injury or risk of damage to property. Do not use any breakable objects while driving. Only stow breakable objects in closed storage compartments.

Rear seat

Rear cup holder

Safety information

WARNING

Unsuitable containers in the cup holder and hot beverages can damage the cup holder and increase the risk of injury in the event of an accident. There is a risk of injury or risk of damage to property. Use light-weight, unbreakable, and sealable containers. Do not transport hot beverages. Do not force objects into the cup holder.

Overview

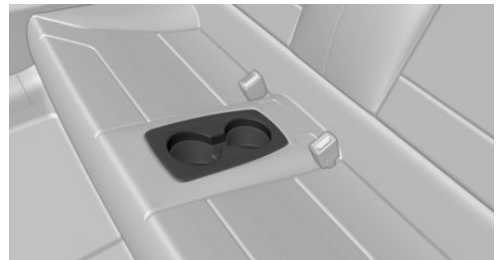

Between the seats.



Clothes hooks

Safety information

WARNING

Clothing articles on the clothes hooks can obstruct the view while driving. There is a risk of an accident. When suspending clothing articles from the clothes hooks, ensure that they will not obstruct the driver's view.

WARNING

Improper use of the clothes hooks can lead to a risk of objects flying about during braking and evasive maneuvers. There is a risk of injury and risk of damage to property. Only hang lightweight objects, for instance clothing articles, from the clothes hooks.

General information

Two folding clothes hooks are provided in the rear of the vehicle. To unfold them, press on the top edge of the clothes hooks.

Storage compartments in the cargo area

Retaining strap

A retaining strap is available on the right and left side trim for fastening small objects.

Lashing eyes in the cargo area

To secure the cargo, refer to page [203](#), there are four lashing eyes in the cargo area.







① DRIVING TIPS

Things to remember when driving	198
Loading	202
Increasing the range	204

Things to remember when driving

Vehicle features and options

This chapter describes all standard, country-specific and optional features offered with the series. It also describes features that are not necessarily available in your vehicle, e. g., due to the selected options or country versions. This also applies to safety-related functions and systems. When using these functions and systems, the applicable laws and regulations must be observed.

Breaking-in period

General information

Moving parts need to begin working together smoothly.

The following instructions will help you to achieve a long vehicle life and good efficiency.

Safety information

WARNING

Due to new parts and components, safety and driver assistance systems can react with a delay. There is a risk of an accident. After installing new parts or with a new vehicle, drive conservatively and intervene early if necessary. Observe the break-in procedures of the respective parts and components.

Range Extender

The full performance of the Range Extender is available after a brief operating period and is only minimally restricted during the run-in phase.

Control of the Range Extender during and after the run-in phase, as well as the activation of the full performance, are preset depending on the system and take place automatically.

Tires

Tire traction is not optimal due to manufacturing circumstances when tires are brand-new; they achieve their full traction potential after a break-in time.

Drive conservatively for the first 200 miles/300 km.

Brake system

Brake discs and brake pads only reach their full effectiveness after approx. 300 miles/500 km. Drive moderately during this break-in period.

Following part replacement

The same break-in procedures should be observed if any of the components above-mentioned have to be renewed in the course of the vehicle's operating life.

Using eDRIVE efficiently

Concept

eDRIVE operates automatically. Proactive driving utilizes energy consumption and energy recovery optimally. Energy recovery is used to charge the high-voltage battery. Energy recovery is important for the supply of electrical components and thus a prerequisite for an extensive range. Energy consumption and recovery depend very much, among other things, on your driving style.

Optimizing driving style

Performance display

Your driving style can be optimized using the performance display.



The energy recovery occurs during coasting and braking and is displayed in the performance display by the accelerator pedal indicator.

The accelerator pedal pointer is within the CHARGE range.

Efficient energy recovery:

- ▶ The accelerator pedal moves to the left within the blue range of the CHARGE display, arrow 1.
- ▶ The energy use while driving can be optimized by efficient acceleration.

Efficient acceleration:

- ▶ The accelerator pedal moves to the right within the blue range of the ePOWER display, arrow 2.
- ▶ Use deceleration during coasting as often as possible for energy recovery.

Discharge of the high-voltage battery

General information

Longer idle periods, refer to page 262, can reduce the charge state of the high-voltage battery.

Safety information

⚠ NOTICE

The high-voltage battery can be damaged by excessive discharge. There is a risk of damage to property. Before storing the vehicle for an extended period, ensure that the high-voltage battery is fully charged. During the idle period,

connect the vehicle to a charging station at a compatible charging location. If necessary, the high-voltage battery will be charged automatically. Make sure that the charging process takes place. Regularly check the charge state. Do not allow the vehicle to sit idle for longer than four weeks with a charge state below approx. 80 %.

General driving notes

Closing the tailgate

Safety information

⚠ WARNING

An open tailgate protrudes from the vehicle and can endanger occupants and other traffic participants or damage the vehicle in the event of an accident, braking or evasive maneuvers. In addition, exhaust fumes may enter the car's interior. There is a risk of injury or risk of damage to property. Do not drive with the tailgate open.

Driving with the tailgate open

If driving with the tailgate open cannot be avoided:

- ▶ Close all windows and the glass sunroof.
- ▶ Greatly increase the air flow from the vents.
- ▶ Drive moderately.

Hot exhaust gas system

⚠ WARNING

During driving operation, high temperatures can occur underneath the vehicle body, for instance caused by the exhaust gas system. If combustible materials, such as leaves or grass, come in contact with hot parts of the exhaust gas system, these materials can ignite. There is a risk

of injury or risk of damage to property. Do not remove the heat shields installed and never apply undercoating to them. Make sure that no combustible materials can come in contact with hot vehicle parts in driving operation, idle or during parking. Do not touch the hot exhaust gas system.

Mobile communication devices in the vehicle

WARNING

Vehicle electronics and mobile phones can influence one another. There is radiation due to the transmission operations of mobile phones. There is a risk of injury or risk of damage to property. If possible, in the car's interior use only mobile phones with direct connections to an exterior antenna in order to exclude mutual interference and deflect the radiation from the car's interior.

Hydroplaning

On wet or slushy roads, a wedge of water can form between the tires and road surface.

This phenomenon is referred to as hydroplaning. It is characterized by a partial or complete loss of contact between the tires and the road surface, ultimately undermining your ability to steer and brake the vehicle.

Driving through water

General information

When driving through water, follow the following:

- ▶ Drive through calm water only.
- ▶ Drive through water only if it is not deeper than maximum 9.8 in/25 cm.
- ▶ Drive through water no faster than walking speed, up to 3 mph/5 km/h.

Safety information

NOTE

When driving too quickly through too deep water, water can enter into the engine compartment, the electrical system or the transmission. There is a risk of damage to property. When driving through water, do not exceed the maximum indicated water level and the maximum speed for driving through water.

Braking safely

General information

The vehicle is equipped with ABS as a standard feature.

Perform an emergency stop in situations that require such.

Steering is still responsive. You can still avoid any obstacles with a minimum of steering effort.

Pulsation of the brake pedal and sounds from the hydraulic circuits indicate that ABS is in its active mode.

In certain situations, for instance when coasting, the accelerator pedal can be used for decelerating, refer to page 105.

In certain braking situations, the perforated brake discs can emit functional noises. Functional noises have no effect on the performance and operational reliability of the brake.

Objects in the movement area around pedals and floor area

WARNING

Objects in the driver's floor area can limit the pedal distance or block a depressed pedal. There is a risk of an accident. Stow objects in the vehicle such that they are secured and cannot enter into the driver's floor area. Use floor mats that are suitable for the vehicle and can be safely attached to the floor. Do not use

loose floor mats and do not layer several floor mats. Make sure that there is sufficient clearance for the pedals. Ensure that the floor mats are securely fastened again after they were removed, for instance for cleaning.

Hills

General information

On downhill sections, use energy recovery if possible to decelerate the vehicle.

Safety information

WARNING

Light but consistent brake pressure can lead to high temperatures, brakes wearing out and possibly even brake failure. There is a risk of an accident. Avoid placing excessive stress on the brake system.

WARNING

In idle state or with drive-ready state switched off, safety-relevant functions, for instance engine braking effect, braking force boost and steering assistance, are restricted or not available at all. There is a risk of an accident. Do not drive in idle state or with drive-ready state switched off.

Brake disc corrosion

Corrosion on the brake discs and contamination on the brake pads are increased by the following circumstances:

- ▶ Low mileage.
- ▶ Extended periods when the vehicle is not used at all.
- ▶ Infrequent use of the brakes.
- ▶ Aggressive, acidic, or alkaline cleaning agents.

Corrosion buildup on the brake discs will cause a pulsating effect on the brakes in their response - generally this cannot be corrected.

Condensation water under the parked vehicle

When using the automatic climate control, condensation water develops and collects underneath the vehicle.

Driving on racetracks

Higher mechanical and thermal loads during racetrack operation lead to increased wear. This wear is not covered by the warranty. The vehicle is not designed for use in motor sports competition.

Loading

Vehicle features and options

This chapter describes all standard, country-specific and optional features offered with the series. It also describes features that are not necessarily available in your vehicle, e. g., due to the selected options or country versions. This also applies to safety-related functions and systems. When using these functions and systems, the applicable laws and regulations must be observed.

Safety information

WARNING

High gross weight can overheat the tires, damage them internally and cause a sudden drop in tire inflation pressure. Driving characteristics may be negatively impacted, reducing lane stability, lengthening the braking distances and changing the steering response. There is a risk of an accident. Pay attention to the permitted load capacity of the tires and never exceed the permitted gross weight.

WARNING

Loose objects or devices with a cable connection to the vehicle, for instance mobile phones, can be thrown into the car's interior while driving, for instance in the event of an accident or during braking and evasive maneuvers. There is a risk of injury. Secure loose objects or devices with a cable connection to the vehicle in the car's interior.

WARNING

Unexpected movements of the backrest while driving may occur due to unintentional unlocking of the rear backrests by the straps. There is a risk of injury. Do not fasten any objects to the straps for unlocking the rear backrests.

WARNING

Improperly stowed objects can shift and be thrown into the car's interior, for instance in the event of an accident or during braking and evasive maneuvers. Vehicle occupants can be hit and injured. There is a risk of injury. Stow and secure objects and cargo properly.

NOTE

Fluids in the cargo area can cause damage. There is a risk of damage to property. Make sure that no fluids leak in the cargo area.

NOTE

When the cargo floor panel is not inserted, there can be damage to the engine cover when loading the cargo area. There is a risk of damage to property. Only load the cargo area if the cargo floor panel is inserted.

Steps for Determining Correct Load Limit

1. Locate the statement “The combined weight of occupants and cargo should never exceed XXX kg or XXX lbs.” on your vehicle’s placard.
2. Determine the combined weight of the driver and passengers that will be riding in your vehicle.
3. Subtract the combined weight of the driver and passengers from XXX kg or XXX lbs.
4. The resulting figure equals the available amount of cargo and luggage load capacity. For example, if the “XXX” amount equals 1,400 lbs. and there will be five 150 lb passengers in your vehicle, the amount of available cargo and luggage load capacity is 650 lbs. (1,400–750 (5 x 150) = 650 lbs.)
5. Determine the combined weight of luggage and cargo being loaded on the vehicle. That weight may not safely exceed the available cargo and luggage load capacity calculated in Step 4.
6. If your vehicle will be towing a trailer, load from your trailer will be transferred to your vehicle. Consult this manual to determine how this reduces the available cargo and luggage load capacity of your vehicle.

Load

The diagram shows three rows of load calculations:

- Row 1: One person icon + five suitcase icons \leq Max. Load
- Row 2: Three person icons + three suitcase icons \leq Max. Load
- Row 3: Four person icons + one suitcase icon \leq Max. Load

The maximum load is the sum of the weight of the occupants and the cargo.

The greater the weight of the occupants, the less cargo that can be transported.

Stowing and securing cargo

- ▶ Do not exceed permissible rear axle load.
- ▶ Cover sharp edges and corners on the cargo.
- ▶ Heavy cargo: stow as far forward as possible, directly behind and at the bottom of the rear passenger seat backrests.
- ▶ Very heavy cargo: when the rear seat is not occupied, secure each of the safety belts in the opposite buckle.
- ▶ If necessary, fold down the rear backrests to stow cargo.
- ▶ Do not stack cargo above the top edge of the backrests.
- ▶ Smaller and light cargo: secure with ratchet straps or draw straps.
- ▶ Larger and heavy cargo: secure with cargo straps.

Lashing eyes in the cargo area

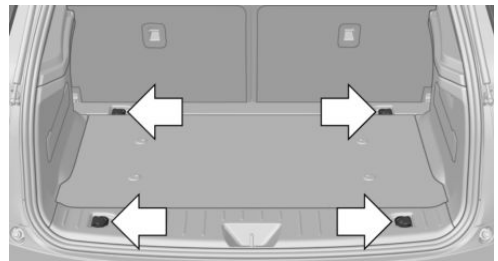

There are four lashing eyes in the cargo area for securing cargo.

Attach load securing aids, such as lashing straps, retaining straps, draw straps or cargo nets, to the lashing eyes in the cargo area.

Increasing the range

General information

The vehicle contains comprehensive technologies for reducing the energy consumption and for maximizing the range.

The range depends on a number of different factors.

The implementation of certain measures, driving style and regular maintenance can increase the range and thereby also reduce the environmental impact.

Remove unnecessary cargo

Additional weight reduces the range.

Remove attached parts following use

Attached parts on the vehicle impair the aerodynamics and increase the energy consumption.

Close the windows and glass sunroof

Driving with the glass sunroof and windows open results in increased air resistance and thereby reduces the range.

Tires

General information

Tires can affect energy consumption in various ways, for instance energy consumption can be influenced by tire size.

Check the tire inflation pressure regularly

Check and, if needed, correct the tire inflation pressure at least twice a month and before starting on a long trip.

Low tire inflation pressure increases rolling resistance and thus raises energy consumption and tire wear.

Stationary climate control

Run advance climate control, refer to page 178, in the vehicle during charging before driving off.

Heating and cooling operations are very energy intensive and substantially reduce the electric range.

Look well ahead when driving

Driving smoothly and proactively reduces energy consumption.

Avoid unnecessary acceleration and braking.

By maintaining a suitable distance to the vehicle driving ahead of you.

Longer braking procedures result in more efficient charging of the high-voltage battery via energy recovery from braking.

Use accelerator pedal for deceleration and coasting

When approaching a red light, use accelerator pedal for decelerating.

For going downhill use coasting function; for this purpose, press accelerator pedal just enough that the vehicle rolls.

Switch off any functions that are not currently needed

Functions such as the rear window defroster require a lot of energy and reduce the range, especially in city and stop-and-go traffic.

Switch off these functions if they are not needed.

The ECO PRO and ECO PRO+ driving modes support the energy-conserving use of comfort features. They automatically perform a partial or complete deactivation of these functions.

Have maintenance carried out

Have the vehicle maintained regularly to achieve optimal vehicle efficiency and service life. BMW recommends that maintenance work be performed by a BMW dealer's service center.

For information on the BMW Maintenance System, refer to page [249](#).

ECO PRO and ECO PRO+

Concept

ECO PRO and ECO PRO+ support an efficient driving style. To this end, the control of the drive is optimized for moderate acceleration, and adapted to lighting and comfort features, such as climate control output. Some vehicle functions cannot be used during activated driving mode ECO PRO and ECO PRO+.

In addition, context-sensitive instructions are displayed to assist with an optimized fuel consumption driving style.

General information

ECO PRO mode and ECO PRO+ mode each have different settings.

ECO PRO

- ▶ Reduction of the heating output and switch-on duration for exterior mirror, rear window, and seat heating.
- ▶ Reduction of the cooling or heating output of the air conditioner.
- ▶ The speed is limited to an adjustable maximum value between 50 mph/80 km/h and 80 mph/130 km/h. To intentionally exceed the speed limit, press the accelerator pedal all the way down.

ECO PRO+

The cooling and heating output of the air conditioner are additionally deactivated on ECO PRO+ activation.

The low beams are dimmed.

The maximum speed is limited to 55 mph/90 km/h. In special situations, the speed limit can be consciously exceeded by applying the accelerator pedal.

Activating ECO PRO and ECO PRO+



Press the button repeatedly, until ECO PRO or ECO PRO+ is displayed in the instrument cluster.

Configuring ECO PRO

Via the Driving Dynamics Control

1. Activate ECO PRO.
2. "Configure ECO PRO"
3. Select the desired setting.

Via iDrive

1. "My Vehicle"
2. "Vehicle settings"
3. "Configure ECO PRO"
4. Select the desired setting.

Settings are stored for the profile currently used.

Activating/deactivating the functions

The following functions can be activated/deactivated:

- ▷ "ECO PRO speed warning"
- ▷ "ECO PRO climate control"

Settings are stored for the driver profile currently used.

ECO PRO limit

- ▷ Activate the ECO PRO limit:
"ECO PRO speed warning":

An ECO PRO tip is displayed if the speed of the set ECO PRO limit is exceeded.

- ▷ Adjust the ECO PRO limit speed:
"Limit at:"
Select the desired speed.

ECO PRO climate control

To activate ECO PRO climate control:
"ECO PRO climate control"

Climate control is set to be fuel-efficient.

That is, it is possible to deviate slightly from the set temperature or to heat or cool the car's interior more slowly, to economize on fuel consumption.

In addition, the power output to the seat and mirror heating is reduced.

Coasting

With little pressure on the accelerator pedal, the vehicle can coast without energy recovery. The accelerator pedal indicator in the instrument display is centered between CHARGE and ePOWER during coasting.

ECO PRO potential savings

Shows potential savings with the current settings in percentages.

Display in the instrument cluster

ECO PRO efficiency display



A mark in the performance display informs about the current driving style.

Mark in the CHARGE range, arrow 1: indication for energy recovery and braking.

Mark in the ePOWER area, arrow 2: display when accelerating.

Your driving style's efficiency is shown by the bar's color:

- ▷ Blue display: efficient driving style as long as the mark moves within the blue range.
- ▷ Gray display: modify driving style, for instance by reduced acceleration.

The display turns blue as soon as all conditions for driving with optimized fuel efficiency are met.

ECO PRO Tip

Driving tip

As soon as one of the conditions for efficient driving is no longer fulfilled, respective driving tips are displayed as a symbol in the instrument cluster.

Symbols

An additional symbol and a SMS text message are displayed on the control display.

Symbol	Measure
	For efficient driving back off the accelerator or delay accelerating to allow time to assess road conditions.
	Reduce speed to the selected ECO PRO speed.



Indications on the Control Display

General information

Information on fuel consumption and technology can be displayed while driving.

eDRIVE

Via iDrive:

1. "My Vehicle"
2. "Technology in action"
3. "eDRIVE"

Driving style analysis

Concept

In this situation, the function helps develop an especially efficient driving style and to save energy.

For this purpose, the driving style is analyzed. The assessment is done in various categories and is displayed on the Control Display.

This display will help you adjust your driving style and save some fuel.

The last 15 minutes of a trip are evaluated.

The range of the vehicle can be extended by adopting an efficient driving style.

Functional requirement

The function is available in ECO PRO mode and in ECO PRO+ mode.

Calling up ECO PRO driving style analysis

Via iDrive:

1. "My Vehicle"
2. "Technology in action"
3. "Driving style analysis"

Display on the Control Display

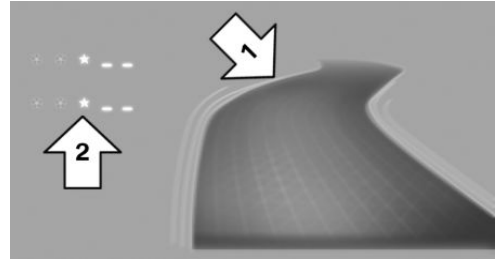

The display of the ECO PRO driving style analysis consists of a symbolized route and a lookup table.

The road symbolizes the efficiency of the driving style. The more efficient your driving style, the smoother the depicted route becomes, arrow 1.

The table of values contains stars, arrow 2. The more efficient the driving style, the more stars are displayed in the table.

If, on the other hand, the driving style is inefficient, a more wavy road and a reduced number of stars are displayed.

To assist with an efficient driving style, ECO PRO tips are displayed during driving.

Tips for an energy-saving driving style, Increasing the range, refer to page 204.





MOBILITY

Charging the vehicle	210
Refueling	221
Fuel	224
Wheels and tires	226
Under the hood	242
Engine oil	244
Coolant	247
Maintenance	249
Replacing components	251
Breakdown assistance	254
Care	258

Charging the vehicle

Vehicle features and options

This chapter describes all standard, country-specific and optional features offered with the series. It also describes features that are not necessarily available in your vehicle, e. g., due to the selected options or country versions. This also applies to safety-related functions and systems. When using these functions and systems, the applicable laws and regulations must be observed.

Concept

The vehicle can be charged using various charging cables at charging stations or household sockets. Control and monitoring of the charging process are handled completely automatically. The charge current strength can be set via iDrive.

General information

High-voltage battery

The high-voltage battery is used as an energy accumulator. The high-voltage battery can be charged by energy recovery during the trip or via the power grid.

In order to operate the high-voltage battery optimally, charge the vehicle regularly and completely on a compatible charger.

When charging via the power grid, you can choose between the following variants.

- ▶ Level 1 charging via a household socket.
- ▶ Level 2 charging via a Level 2 charging station.

- ▶ Charging via a DC charging station.

Level 1 charging is possible via a household socket with a voltage of 120 volts.

For optimal use of the energy from the power grid, charging at a Level 2 charging station, such as BMW i Wallbox, is recommended.

Charge current

General information

The charge current strength is indicated in amperes.

The vehicle cannot automatically detect the maximum permissible charge current strength of the power grid during charging via a household socket or charging station.

Level 1 charging

Prior to the first Level 1 charging at your own household socket, as well as when charging at external electrical power sockets in Level 1, the allowed charge current strength must be determined, for instance by a qualified electrician.

The charge current strength for Level 1 charging, refer to page 217, can be adjusted in the vehicle in three levels.

At delivery, the charge current for Level 1 charging is set to the lowest level.

Depending on the country-specific version, one of several ampere ratings is printed on the Level 1 charging cable. This ampere rating is the limit which must be adhered to for the vehicle if the charge current is set to the highest level. Depending on the charging cable, the charge current strength may vary when lower levels are set.

Overview

Imprint on the charging cable	Charge current setting		
	"Max."	"Reduced"	"Low"
8 A	8 A	6 A	6 A
10 A	10 A	7.5 A	6 A
12 A	12 A	9 A	6 A
15 A	15 A	11.25 A	7.5 A

Charging at a Level 2 charging station

The permitted charge current strength must be determined prior to charging at a Level 2 charging station, for instance from the operator of the Level 2 charging station. The permitted charge current strength can vary by country.

The charge current strength for Level 2 charging, refer to page 217, can be adjusted in the vehicle in two steps.

At delivery, the charge current for Level 2 charging is set to "Reduced". Maintain this setting unless it was verified that a higher charge current strength is permitted in the individual case.

The charge current changes depending on the setting.

"Max."	"Reduced"
32 A	16 A

Depending on the charge current, the charging duration changes.

Range Extender

With Range Extender switched on, the current charge state can be maintained. In this way, a higher range is achieved.

Safety information

WARNING

Improper working with electrical current can lead to an electric shock due to high voltages or high currents. There is a risk of fire or danger to life. Observe the general safety regulations when working with electrical current.

WARNING

A faulty and incorrectly designed charging device at the charging location can cause damage to the vehicle and overload the power mains at the charging location. There is a risk of fire and a risk of injury.

The manufacturer of your vehicle recommends that, prior to your first use of a charging location, you have the compatibility of the following components confirmed:

- ▷ Charging cable.
- ▷ Charging station.
- ▷ Household socket and connected circuits.

WARNING

Damaged or worn charging devices, for instance worn contacts, can heat up. There is a risk of fire. Only use charging devices in proper state.

⚠ WARNING

If a sufficient safety distance from easily flammable materials is not maintained, simultaneous charging and filling with fuel can cause a risk of fire. There is a risk of injury or risk of damage to property. Do not fill the vehicle with fuel and charge it simultaneously.

⚠ WARNING

Contact with live components can lead to an electric shock. High voltage is applied at the charging connection. There is a risk of injury or danger to life.

The manufacturer of your vehicle recommends that work on the charging connection, for instance cleaning, be performed only by an authorized BMW i dealer's service center or another qualified service center or repair shop.

A dealer's service center will be glad to provide information about suitable charging cables.

⚠ WARNING

Improper use of the charging cable can prevent charging and lead to damage, for instance cable fire. There is a risk of fire. Use the charging cable only for charging the vehicle, and do not extend it using cables or adapters.

⚠ WARNING

Damaged charging cables can heat up or lead to an electric shock. There is a risk of fire or a risk of injury. Use undamaged charging cables only.

Charging cable

General information

Use a Level 1 charging cable, Level 2 charging cable or the permanently installed charging cable of a charging station to charge the vehicle.

Different charging cables can be required depending on the country.

Safety information

⚠ WARNING

Non-compatible charging cables or unsuitable charging stations can heat up and cause damage to the vehicle. There is a risk of fire. Use charging cables or charging stations for charging that are suitable for the respective vehicle type.

Level 1 charging cable

The vehicle is supplied with a Level 1 charging cable.

With the Level 1 charging cable, it is permissible to perform charging from grounded household sockets. At the power connection of a household socket, charging is done with alternating current.

When a Level 1 charging cable is used, this may produce efficiency values other than indicated on the energy label.

Level 2 charging cable

The Level 2 charging cable makes it possible to quickly recharge at sockets of designated Level 2 charging stations using a special plug. Charging is performed with alternating current at designated Level 2 charging stations. The charging process can be completed faster than at household sockets.

If necessary, the charging cable is attached to the charging station.

If a Level 2 charging cable is used, apply the corresponding setting via iDrive, refer to page [217](#).

DC charging cable

The DC charging cable that is permanently installed at the charging station makes it possible to charge at DC charging stations. Charging is performed with direct current at designated DC charging stations. At the higher capacity current connection of a DC charger station the charging time is significantly lower than with a household socket or a Level 2 charging station.

During charging at a DC charging station, an indication in the instrument cluster, refer to page 218, is displayed.

The DC charging cable is also referred to as Level 3 DC charging cable.

Storage

The Level 1 charging cable is located in the charging cable compartment under the hood.

The Level 2 charging cable can be stored in the same place.

Moisture can penetrate into the charging cable compartment, for instance in a vehicle wash.

If required, store the charging cable with the installed plug cover to prevent moisture in the charging cable plug.

Connecting

Connecting the charging cable

To connect, engage selector lever position P, deactivate drive-ready state, and unlock the vehicle. Set the parking brake, if needed.

1. Tap on the charging socket flap, arrow.



2. Remove the charging socket lid, arrow.

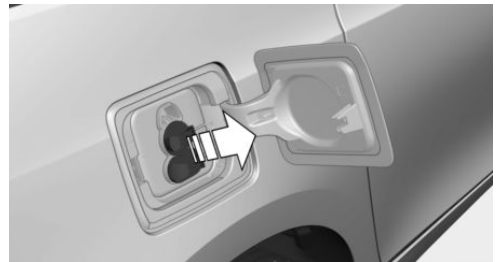

3. Remove cover of the charging cable plug, if needed.
4. Connect Level 1 charging cable to the household socket or Level 2 charging cable to the port on the charging station.
5. Insert the charging cable plug corresponding to the charging socket, and push it in until it engages.

When charging at a charging station, follow the instructions at the charging station.

Remove

When the charging process is active and the vehicle is locked, the charging cable is locked. Unlock the vehicle before removing the cable.

When the charging process is completed, the charging cable is automatically unlocked.

If necessary, clean the area between charging socket flap and charging socket, for instance from snow, before removing it.

1. Unlock the vehicle by remote control if it is locked.

Charging cable is unlocked.

2. Press the release button on the handle, arrow 1, and grasp the charging cable at the gripping areas.

Charging process is interrupted.

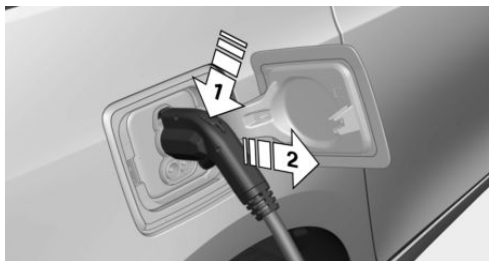

3. Remove the charging cable from the charging socket, arrow 2.
4. Put the charging socket lid back on.
5. Close the charging socket flap.
6. Attach cover of the charging cable plug, if needed.
7. Disconnect Level 1 charging cable from the household socket or Level 2 charging cable from the port on the charging station as needed.
8. Stow the charging cable.

At a charging station, insert the permanently installed charging cable in the place provided for it.

Always keep charging socket clean and unobstructed.

Keep the charging socket flap closed when the charging socket is not used.

Manual release

General information

The charging socket flap is automatically locked while driving.

The charging cable may be locked during the charging process if the vehicle is locked.

Manually unlocking the charging socket flap

In case of an electrical malfunction of the charging cable lock, the charging socket flap can be manually unlocked.

1. Open the front door on the side of the charging socket flap.
2. Open rear door on the side of the charging socket flap.
3. Remove the cover.
4.  Pull the top knob. This releases the charging socket flap.

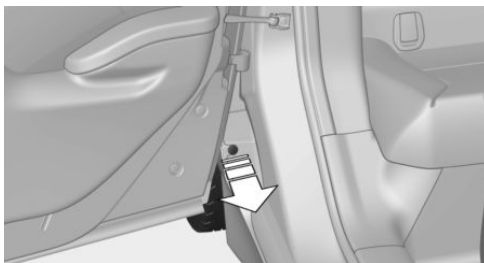

5. If necessary, press the knob back into the initial position.

Manually unlocking the charging cable

In case of an electrical malfunction, the charging cable can be manually unlocked.

When charging at a charging station, complete the charging process at the charging station before unlocking the charging cable.

1. Open the front door on the side of the charging socket flap.
2. Open rear door on the side of the charging socket flap.
3. Remove the cover.
4.  Pull the lower knob.

Charging cable is manually unlocked.

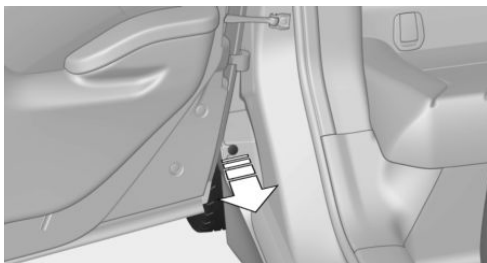

5. Removing the charging cable, refer to page 213.
6. If necessary, press the knob back into the initial position.

Have the locking system of the charging socket checked at the dealer's service center or another qualified service center or repair shop after manual unlocking of the charging cable.

Charging process

Safety information

WARNING

Improper use of the power mains connection can lead to damage, for instance cable fire. There is a risk of injury or risk of damage to property. Use the charging cable only for charging the vehicle, and do not extend it using cables or adapters.

WARNING

If the charge current strength is adjusted incorrectly, the power mains of the household socket can be overloaded and overheat. There is a risk of fire. Adjust the charge current strength to the power mains prior to charging on household sockets. With unknown power networks, set on the lowest level.

Starting the charging process

1. Engage selector lever position P. Set the parking brake, if needed.
2. Planning the charging process, refer to page 216.
3. Switch off drive-ready state.
4. Connect Level 1 charging cable to the household socket or Level 2 charging cable to the port on the charging station.
5. Open charging socket flap.
6. Connect charging cable to the vehicle, refer to page 213.
7. Lock vehicle if it is unlocked.

At high temperatures, the high-voltage battery is initially cooled. There may be a delay before charging starts. If the high-voltage battery is discharged, cooling of the high-voltage battery may not be possible. The charging process cannot be started.

If the Level 1 charging cable is exposed to high temperatures and direct sunlight, this may interrupt the charging process. Charging resumes automatically.

The charging process may take longer under extremely low or high temperatures.

Display of the charging status

Indicator light on the charging socket



An indicator light is located on the charging socket.

Charging status

Light	Charging status
White	Charging cable can be connected or removed.
Flashes yellow	Charging process is being prepared. For DC charging; DC charging is finishing.
Blue	The charging process starts at the set time.
Flashes blue	Charging process is active.
Flashes red	Fault in the charging process.
Green	Charging process is completed.

When the vehicle is locked, the indicator light goes out after some time.

When the vehicle is unlocked, the blue indicator light flashes continuously. The other indicator lights go out after some time.

🔑 Press the button of the remote control to check the charging status. The charging status is indicated on the indicator light. In some cases the vehicle is locked.

Additional messages about the charging status can be displayed in the instrument cluster, on the BMW display key, or via the BMW Connected app on a smartphone.

Planning the charging process

General information

The charging process can be adapted to constraints, for instance the cost of electricity. The vehicle can control the charging process in such a way that the charging process is completed at the departure time. A departure time must be set for this purpose, refer to page 219.

The following settings are available:

- ▶ Immediate charging.
- ▶ Set time window for favorable charging.
- ▶ Set charging via a Level 1 charging cable.
- ▶ Set charging via a Level 2 charging cable.

If drive-ready state is switched off, changes can be made via iDrive. Departure time can only be changed once. Scheduled departure times are not adjusted. Settings for stationary climate control and charging process are also accepted for planned departure times.

Immediate charging

The charging process starts as soon as the charging cable is connected.

Via iDrive:

1. "My Vehicle"
2. "Plan charging/climate control"
3. "Charge immediately"

Setting time window for favorable charging

Level 1 or Level 2 charging:

When departure time is set, a time window for charging with a favorable electricity rate can be set via iDrive.

Via iDrive:

1. "My Vehicle"
2. "Plan charging/climate control"
3. "Charge for departure time"
4. "Set low cost time slot"
5. Set rate begin.
6. Set rate end.

The Digital Charging Service enables the time window to be set automatically for certain locations. Further information about the Digital Charging Service is available on the Internet:

<https://charging.bmwgroup.com>

The vehicle can also start the charging process before the selected time window begins or end it after the selected time window finishes. The starting point of the charging process is adjusted so the vehicle can be fully charged and, if applicable, its climate controlled right up to the departure time.

If drive-ready state is switched off, changes can be made via iDrive.

The set time window can be ignored for the next charging process: "Charge immediately once"

Setting the charge current for charging via a Level 1 charging cable

Depending on the electrical mains, the vehicle must be charged with a different charging current strength, refer to page 210.

Via iDrive:

1. "My Vehicle"
2. "Plan charging/climate control"
3. "Settings charging current"

Settings are stored. When you change charging locations you also might need to change the setting for charging.

Set the charge current strength at other household sockets to the lowest level.

Setting the charge current for charging via a Level 2 charging cable

Depending on the electrical mains, the vehicle must be charged with a different charging current strength, refer to page 211.

When charging with a Level 2 charging cable, the charging process can be completed faster at a Level 2 charging station.

Via iDrive:

1. "My Vehicle"
2. "Plan charging/climate control"
3. "Level 2 (208-240V)"

Settings are stored. When you change charging locations you also might need to change the setting for charging.

Automatically unlocking the charging cable after the charging process

To allow other charging station customers to use the charging function, the charging cable can be unlocked automatically after the charging process is complete.

Via iDrive:

1. "My Vehicle"
2. "Plan charging/climate control"
3. "Settings charging current"
4. "Unlock charging cable"

Stopping the charging process

The charging process can be stopped at any time by removing the charging cable and continued at a later time by connecting the charging cable. This enables, for instance the use of other loads on the power connection or prevents simultaneous high power from multiple loads.

Removing the charging cable, refer to page 213.

Continuing the charging process

If the charging process is interrupted, for instance through a temporary power failure, the

charging process is automatically continued after the interruption.

Terminating the charging process

1. Removing the charging cable from the vehicle, refer to page 213.
2. Stow the charging cable as required.
3. Close the charging socket flap.
4. Lock vehicle if it is unlocked.

Intelligent charging

Concept

Intelligent charging can adapt the charging process dynamically via the Internet to the environmental condition, such as the availability of solar power or time-variable electricity rates. Intelligent charging is part of BMW's Digital Charging Service.

Further information about the Digital Charging Service is available on the Internet:

<https://charging.bmwgroup.com>

General information

No time for the end of charging is displayed in the instrument cluster for intelligent charging.

If drive-ready state is switched off, changes can be made via iDrive.

Intelligent charging can be ignored for the next charging process.

1. Switch off drive-ready state.
2. "Charge immediately once"

Functional requirements

- ▶ Account on the BMW charging portal.
- ▶ A subscription to the intelligent charging service has been obtained.
- ▶ Suitable Wallbox.
- ▶ Departure time set, refer to page 219.
- ▶ Charge current strength setting to highest level, refer to page 217.

Configuring the BMW charging service

Use one of the following to configure the BMW charging service:

- ▶ BMW remote app on the smartphone.
- ▶ BMW charging portal in the Internet.

Activating intelligent charging

Via iDrive:

1. "My Vehicle"
2. "Plan charging/climate control"
3. "Charge for departure time"
4. "Intelligent charging"

Displays in the instrument cluster

The charge state indicator light shows the charge state of the high-voltage battery in the instrument cluster, if standby state is switched on. If all bars are filled, the high-voltage battery is fully charged.

Even if no bars are filled, the high-voltage system is still under high voltage.

Information regarding the charging process are shown on the charging screen.

Display Meaning



Blue plug: charging process active or completed.

White plug: charging process interrupted.



Running light: animated with active charging process.









End of charging time or set departure time.



Charging progress bar.

Running light: animated with active charging process.

Display	Meaning
	DC charging active on a DC charging station.
65mi	Indicator in blue: charged electrical range.
85mi	Indicator in white: maximum electrical range.
	White clock: departure time set. Blue plug: charging process active or completed. White plug: charging process interrupted.
	Climate control activated at departure time.
	Range with Range Extender.
	Flashing: ventilation active.
	Flashing: heating active.
	Flashing: cooling active.

Departure time

Concept

For optimum range and climate control, the departure time can be set before parking the vehicle.

General information

With a set departure time, the vehicle is pre-heated or pre-cooled during the charging process if climate control is set. Climate control out-

put is reduced during the trip. This increases the range.

The following settings are possible at departure time:

- ▷ Climate control at departure time.
- ▷ Planning a one-time departure time.
- ▷ Planning of up to three regular departure times per day of the week.

If drive-ready state is switched off, changes can be made via iDrive. Departure time can only be changed once. Scheduled departure times are not adjusted. Settings for climate control and charging process are also applied for scheduled departure times.

Climate control at departure time

Via iDrive:

1. "My Vehicle"
2. "Plan charging/climate control"
3. "Precondition for departure"

Setting the departure time

Level 1 or Level 2 charging:

Via iDrive:

1. "My Vehicle"
2. "Plan charging/climate control"
3. "Set departure time"
4. Set the desired days of the week, if needed.
5. Set the desired time.

Up to three departure times can be set.

Activating the departure time

Via iDrive:

1. "My Vehicle"
2. "Plan charging/climate control"
3. "Set departure time"
 - Set departure times are displayed.
4. For example activate "Departure time 1".

Up to three departure times can be activated.

The set departure time will be deactivated, if the departure time was ignored three times in a row.

Climate control

General information

The following settings for climate control of the vehicle are possible:

- ▶ Activate stationary climate control immediately, refer to page 178.
With stationary climate control activated and no charging cable connected, the range is reduced.
- ▶ Planned climate control at the set departure time, refer to page 179.
If a Mode 2 charging cable is used, the high-voltage battery may not be fully charged at departure time.

Discharged high-voltage and vehicle battery

General information

In addition to the high-voltage battery, the vehicle has a 12 volt vehicle battery, which is required for operation of the onboard electronics.

If the high-voltage battery and the vehicle battery are discharged, it is not possible to operate the vehicle.

Have the vehicle checked and returned to operation by a dealer's service center or another qualified service center or repair shop.

Refueling

Vehicle features and options

This chapter describes all standard, country-specific and optional features offered with the series. It also describes features that are not necessarily available in your vehicle, e. g., due to the selected options or country versions. This also applies to safety-related functions and systems. When using these functions and systems, the applicable laws and regulations must be observed.

General information

Follow the fuel recommendation, refer to page 224, prior to refueling.

A sufficient amount of fuel must be added to operate the Range Extender. When the Range Extender is activated, the current charge state is maintained. The vehicle has a greater range.

Do not refuel unless the engine is at a standstill and the selector lever is in position P/N, otherwise the buildup of pressure may cause the fuel nozzle to shut off prematurely.

Safety information

NOTE

With a driving range of less than 30 miles/50 km the engine may no longer have sufficient fuel. Engine functions are not ensured anymore. There is a risk of damage to property. Refuel promptly.

Tank vent

Concept

The vehicle is equipped with a special fuel tank. The fuel tank is designed for special requirements that arise from operation with the Range Extender.

General information

In the fuel tank, excess pressure can build up due to gasoline vapors which are dissipated before the fuel cap is opened.

Overview

The button is located on the driver's floor area.

Tank venting

1. Switch off drive-ready state.



2.  Press button to start the pressure equalization.

The status of the tank venting is displayed in the instrument cluster. In rare cases, the tank venting can last several minutes.

If the tank venting has been completed, a message is displayed in the instrument cluster. The fuel filler flap is released for opening.

3. Open the fuel filler flap.

If it is not possible to open the fuel filler flap after tank venting, press the button again.

If it is still not possible to open the fuel filler flap even after the button has been pressed, unlock the fuel filler flap manually, refer to page 222.

Fuel cap

Opening

Before opening, vent the tank.

1. Briefly press the rear edge of the fuel filler flap.



2. Turn the fuel cap counterclockwise.

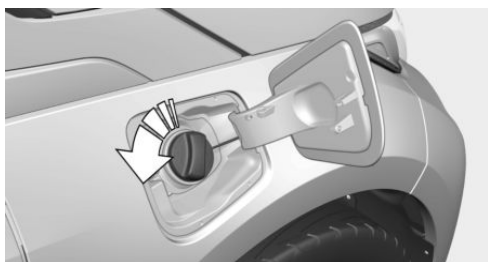

3. Place the fuel cap in the bracket attached to the fuel filler flap.



Closing

⚠ WARNING

The retaining strap of the fuel cap can be jammed and crushed during closing. The cap cannot be correctly closed. Fuel or fuel vapors can escape. There is a risk of injury or risk of damage to property. Pay attention that the retaining strap is not jammed or crushed when closing the cap.

1. Fit the cap and turn it clockwise until you clearly hear a click.
2. Close the fuel filler flap.

Manually unlocking fuel filler flap

E.g., in the event of an electrical malfunction.

The release is located under the hood.

1. Opening the hood, refer to page 243.
2. Pull the green knob with the fuel pump symbol. This releases the fuel filler flap.

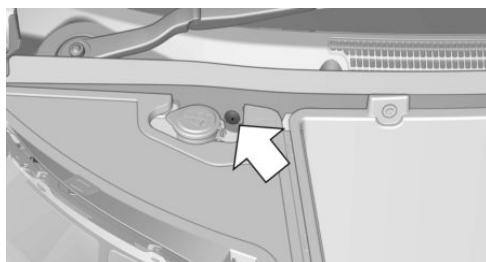

3. Open the fuel filler flap.

- Carefully open the fuel cap. Excess pressure can build up in the fuel tank from gasoline vapor.

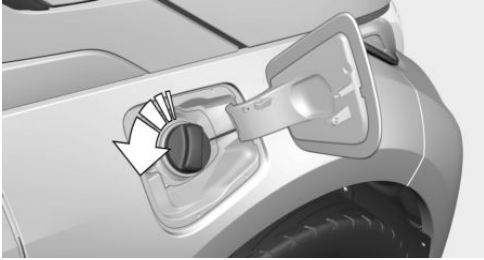

- Fuel the vehicle as usual. The residue pressure in the tank may make refueling difficult, for instance the fuel pump nozzle may shut off frequently.

damage to property. Do not fill the vehicle with fuel and charge it simultaneously.

NOTE

Fuels are toxic and aggressive. Overfilling of the fuel tank can damage the fuel system. Painted surfaces may be damaged by contact with fuel. Escaping fuel can harm the environment. There is a risk of damage to property. Avoid overfilling.

Follow the following when refueling

General information

When refueling, insert the filler nozzle completely into the filler pipe. Lifting up the fuel pump nozzle during refueling causes:

- ▶ Premature switching off.
- ▶ Reduced return of the fuel vapors.

The fuel tank is full when the filler nozzle clicks off the first time.

Make sure that the fuel cap is closed properly after refueling, otherwise the emissions warning light may light up.

Follow safety regulations posted at the gas station.

Safety information

WARNING

If a sufficient safety distance from easily flammable materials is not maintained, simultaneous charging and filling with fuel can cause a risk of fire. There is a risk of injury or risk of

Fuel

Vehicle features and options

This chapter describes all standard, country-specific and optional features offered with the series. It also describes features that are not necessarily available in your vehicle, e. g., due to the selected options or country versions. This also applies to safety-related functions and systems. When using these functions and systems, the applicable laws and regulations must be observed.

Fuel recommendation

General information

Depending on the region, many gas stations sell fuel that has been customized to winter or summer conditions. Fuel that is available in winter, for instance helps make a cold start easier.

Gasoline

General information

For the best fuel efficiency, the gasoline should be sulfur-free or very low in sulfur content.

Fuels that are marked on the gas pump as containing metal must not be used.

Fuels with a maximum ethanol content of 10 %, i. e., E10, may be used for refueling.

Ethanol should meet the following quality standards:

US: ASTM 4806–xx

CAN: CGSB-3.511–xx

xx: comply with the current standard in each case.

Safety information

NOTE

Do not press the Start/Stop button after refueling with the wrong fuel. Furthermore, the catalytic converter is permanently damaged. There is a risk of damage to property. Do not refuel or add the following in the case of gasoline engines:

- ▷ Leaded gasoline.
- ▷ Metallic additives, for instance manganese or iron.

Do not press the Start/Stop button after refueling with the wrong fuel. Contact a dealer's service center or another qualified service center or repair shop.

NOTE

Incorrect fuels can damage the fuel system and the engine. There is a risk of damage to property. Do not use fuels with a higher percentage of ethanol than recommended. Do not refuel with fuels containing methanol, e.g. M5 to M100.

NOTE

Fuel that does not comply with the minimum quality can compromise engine function or cause engine damage. There is a risk of damage to property. Do not fill with fuel that does not comply with the minimum quality.

Recommended fuel grade

BMW recommends AKI 91.

Minimum fuel grade

BMW recommends AKI 89.

Wheels and tires

Vehicle features and options

This chapter describes all standard, country-specific and optional features offered with the series. It also describes features that are not necessarily available in your vehicle, e. g., due to the selected options or country versions. This also applies to safety-related functions and systems. When using these functions and systems, the applicable laws and regulations must be observed.

Tire inflation pressure

General information

The tire inflation pressure and tire characteristics influence the following:

- ▶ The service life of the tires.
- ▶ Road safety.
- ▶ Driving comfort.
- ▶ Driving dynamics.
- ▶ Fuel consumption.

Safety information

WARNING

A tire with too little or no tire inflation pressure may heat up significantly and sustain damage. This will have a negative impact on aspects of handling, such as steering and braking response. There is a risk of an accident. Regularly check the tire inflation pressure, and correct it as needed, for instance twice a month and before a long trip.

Tire inflation pressure specifications

In the tire inflation pressure table

The tire inflation pressure table, refer to page 227, contains all tire inflation pressure specifications for the specified tire sizes at the ambient temperature. The tire inflation pressure values apply to tire sizes approved by the manufacturer of the vehicle for the vehicle type.

To identify the correct tire inflation pressure, please note the following:

- ▶ Tire sizes of your vehicle.

Checking the tire inflation pressure

General information

Tires heat up while driving. The tire inflation pressure increases with the tire temperature.

Tires have a natural, consistent loss of tire inflation pressure.

The displays of inflation devices may under-read by up to 0.1 bar/2 psi.

Checking using tire inflation pressure specifications in the tire inflation pressure table

The tire inflation pressure specifications in the tire inflation pressure table only relate to cold tires or tires at the same temperature as the ambient temperature.

Only check the tire inflation pressure levels when the tires are cold, i.e.:

- ▶ Driving range of max. 1.25 miles/2 km has not been exceeded.

► If the vehicle has not moved again for at least 2 hours after a trip.

1. Determine, refer to page 226, the intended tire inflation pressure levels for the mounted tires.
2. Check the tire inflation pressure in all four tires, using a pressure gage, for example.
3. Correct the tire inflation pressure if the current tire inflation pressure value deviates from the specified value.
4. Check whether all valve caps are screwed onto the tire valves.

After correcting the tire inflation pressure

For run-flat tires: reinitialize run-flat tires.

For the Tire Pressure Monitor TPM: reset the Tire Pressure Monitor TPM.

Tire fill pressures

To achieve optimum driving comfort, note the pressure specifications in the Tire inflation pressure table, refer to page 227, and adjust as needed.

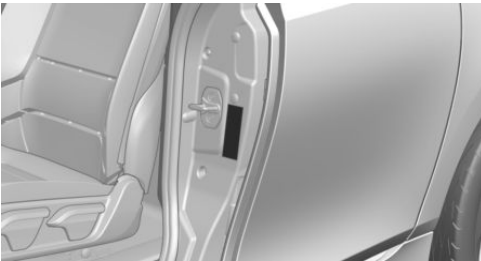

These pressure values can also be found on the tire inflation pressure label on the driver's side on the rear door.

Do not exceed a speed of 100 mph/160 km/h.

Tire inflation pressure values

i3 without Range Extender

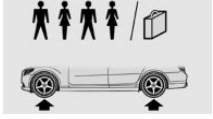
Tire size	Pressure specifications in bar/PSI	
Specifications in bar/PSI with cold tires		
155/70 R 19 84 Q M+S A/S Std	2.3 / 33	2.8 / 41
155/70 R 19 88 Q M+S XL Std		
155/70 R 19 84 Q Std		
Front: 155/70 R 19 84 Q M+S A/S Std	2.3 / 33	-
Rear: 175/60 R 19 86 Q M+S A/S Std	-	2.8 / 41
Front: 155/60 R 20 80 Q Std	2.3 / 33	-
Rear: 175/55 R 20 89 Q XL Std	-	2.8 / 41

i3 with Range Extender

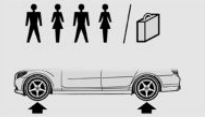
Tire size	Pressure specifications in bar/PSI	
Specifications in bar/PSI with cold tires		
155/70 R 19 88 Q M+S XL Std	2.3 / 33	2.8 / 41

Tire size	Pressure specifications in bar/PSI	
Front: 155/70 R 19 84 Q M+S A/S Std	2.3 / 33	-
Rear: 175/60 R 19 86 Q M+S A/S Std	-	2.8 / 41
Front: 155/70 R 19 84 Q Std	2.3 / 33	-
Rear: 175/60 R 19 86 Q Std	-	2.8 / 41
Front: 155/60 R 20 80 Q Std	2.3 / 33	-
Rear: 175/55 R 20 89 Q XL Std	-	2.8 / 41

i3s

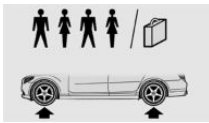
Tire size	Pressure specifications in bar/PSI	
Specifications in bar/PSI with cold tires		
155/70 R 19 88 Q M+S XL Std	2.3 / 33	2.8 / 41
Front: 175/55 R 20 89 T XL Std	2.3 / 33	-
Rear: 195/50 R 20 93 T XL Std	-	2.8 / 41

Tire identification marks

Tire size

245/45 R 18 96 Y

245: nominal width in mm

45: aspect ratio in %

R: radial tire code

18: rim diameter in inches

96: load rating, not for ZR tires

Y: speed rating, before the R on ZR tires

Maximum tire load

Maximum tire load is the maximum permissible weight for which the tire is approved.

Locate the maximum tire load on the tire sidewall and the Gross Axle Weight Rating – GAWR – on the certification label on the driver's side on the rear door.

Divide the tire load by 1.1. It must be greater than one-half of the vehicle's Gross Axle Weight Rating – GAWR. Note, front vs. rear GAWR and tire loads, respectively.

Speed letter

Q = up to 100 mph/160 km/h

R = up to 106 mph/170 km/h

S = up to 112 mph/180 km/h

T = up to 118 mph/190 km/h

H = up to 131 mph/210 km/h

V = up to 150 mph/240 km/h

W = up to 167 mph/270 km/h

Y = up to 186 mph/300 km/h

Tire Identification Number

DOT code: DOT xxxx xxx 0118

xxxx: manufacturer code for the tire brand

xxx: tire size and tire design

0118: tire age

Tires with DOT codes meet the guidelines of the U.S. Department of Transportation.

Tire age

Recommendation

Regardless of the tire tread, replace tires at least every 6 years.

Manufacture date

You can find the manufacture date of the tire on the tire's sidewall.

Designation	Manufacture date
DOT ... 0118	1st week, 2018

Uniform Tire Quality Grading

Quality grades can be found where applicable on the tire sidewall between tread shoulder and maximum section width.

E.g.: Treadwear 200; Traction AA; Temperature A

DOT Quality Grades

Treadwear

Traction AA A B C

Temperature A B C

All passenger vehicle tires must conform to Federal Safety Requirements in addition to these grades.

Treadwear

The treadwear grade is a comparative rating based on the wear rate of the tire when tested under controlled conditions on a specified government test course. E.g., a tire graded 150 would wear one and one-half, 1 g, times as well on the government course as a tire graded 100. The relative performance of tires depends upon the actual conditions of their use, however, and may depart significantly from the norm due to variations in driving habits, service practices and differences in road characteristics and climate.

Traction

The traction grades, from highest to lowest, are AA, A, B, and C.

Those grades represent the tire's ability to stop on wet pavement as measured under controlled conditions on specified government test surfaces of asphalt and concrete. A tire marked C may have poor traction performance.

The traction grade assigned to this tire is based on straight-ahead braking traction tests, and does not include acceleration, cornering, hydroplaning, or peak traction characteristics.

Temperature

The temperature grades are A, the highest, B, and C, representing the tire's resistance to the generation of heat and its ability to dissipate heat when tested under controlled conditions on a specified indoor laboratory test wheel. Sustained high temperature can cause the material of the tire to degenerate and reduce tire life, and excessive temperature can lead to sudden tire failure. The grade C corresponds to a level of performance which all passenger vehicle tires must meet under the Federal Motor Vehicle Safety Standard No. 109. Grades Band A represent higher levels of performance on the laboratory test wheel than the minimum required by law.

WARNING

The temperature grade for this tire is established for a tire that is properly inflated and not overloaded. Excessive speed, underinflation, or excessive loading, either separately or in combination, can cause heat buildup and possible tire failure.

M+S

Winter and all-season tires with better cold weather performance than summer tires.

Tire tread

Summer tires

Do not drive with a tire tread of less than 0.12 in/3 mm, otherwise there is an increased risk of hydroplaning.

Winter tires

Do not drive with a tire tread of less than 0.16 in/4 mm, as such tires are less suitable for winter operation.

Minimum tread depth

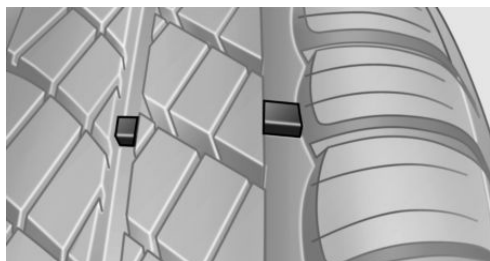

Wear indicators are distributed around the tire's circumference and have the legally required minimum height of 0.063 inches/1.6 mm.

The positions of the wear indicators are marked on the tire sidewall with TWI, Tread Wear Indicator.

Tire damage

General information

Inspect your tires regularly for damage, foreign objects lodged in the tread, and tread wear.

Driving over rough or damaged road surfaces, as well as debris, curbs and other obstacles can cause serious damage to wheels, tires and suspension parts. This is more likely to occur with low-profile tires, which provide less cushioning between the wheel and the road. Be careful to avoid road hazards and reduce your speed, es-

pecially if your vehicle is equipped with low-profile tires.

Indications of tire damage or other vehicle malfunctions:

- ▷ Unusual vibrations.
- ▷ Unusual tire or running noises.
- ▷ Unusual handling such as a strong tendency to pull to the left or right.

Damage can be caused by the following situations, for instance:

- ▷ Driving over curbs.
- ▷ Road damage.
- ▷ Tire inflation pressure too low.
- ▷ Vehicle overloading.
- ▷ Incorrect tire storage.

Safety information

⚠ WARNING

Damaged tires can lose tire inflation pressure, which can lead to loss of vehicle control. There is a risk of an accident. If tire damage is suspected while driving, immediately reduce speed and stop. Have wheels and tires checked. For this purpose, drive carefully to the nearest dealer's service center or another qualified service center or repair shop. Have vehicle towed or transported as needed. Do not repair damaged tires, but have them replaced.

⚠ WARNING

Tires can become damaged by driving over obstacles, e.g., curbs or road damage, at high speed. Larger wheels have a smaller tire cross-section. The smaller the tire cross-section, the higher the risk of tire damage. There is a danger of accidents and property damage. If possible, drive around obstacles, or drive over them slowly and carefully.

Changing wheels and tires

Mounting

Have mounting and wheel balancing carried out by a dealer's service center or another qualified service center or repair shop.

Wheel and tire combination

General information

You can ask the dealer's service center or another qualified service center or repair shop about the correct wheel/tire combination and wheel rim versions for the vehicle.

Safety information

WARNING

Wheels and tires which are not suitable for your vehicle can damage parts of the vehicle, for instance due to contact with the body due to tolerances despite the same official size rating. There is a risk of an accident. The manufacturer of your vehicle strongly suggests that you use wheels and tires that have been recommended by the vehicle manufacturer for your vehicle type.

WARNING

Incorrect wheel/tire combinations will have a negative impact on the vehicle's handling and on the function of a variety of systems, such as ABS or DSC. There is a risk of an accident. To maintain good handling and vehicle response, use only tires with a single tread configuration from a single manufacturer. The manufacturer of the vehicle recommends that you use wheels and tires that have been recommended by the vehicle manufacturer for your vehicle type. Following tire damage, have the original

wheel/tire combination remounted on the vehicle as soon as possible.

Recommended tire brands



For each tire size, the manufacturer of the vehicle recommends certain tire brands. The tire brands can be identified by a star on the tire sidewall.

New tires

Tire traction is not optimal due to manufacturing circumstances when tires are brand-new; they achieve their full traction potential after a break-in time.

Drive conservatively for the first 200 miles/300 km.

Retreaded tires

WARNING

Retreaded tires can have different tire casing structures. With advanced age the service life can be limited. There is a risk of an accident. The manufacturer of your vehicle does not recommend the use of retreaded tires.

The manufacturer of your vehicle does not recommend the use of retreaded tires.

Winter tires

Winter tires are recommended for operating on winter roads.

Although so-called all-season M+S tires provide better winter traction than summer tires, they usually do not provide the same level of performance as winter tires.

Maximum speed of winter tires

If the maximum speed of the vehicle is higher than the permissible speed for the winter tires, then attach a label showing the permissible maximum speed in the field of view. The label is available from a dealer's service center or another qualified service center or repair shop.

With winter tires mounted, observe and do not exceed the permissible maximum speed.

Rotating wheels between axles

Different wear patterns can occur on the front and rear axles depending on individual driving conditions. The tires can be rotated in pairs between the axles to achieve even wear. Further information is available from a dealer's service center or another qualified service center or repair shop. After rotating, check the tire pressure and correct, if needed.

Rotating the tires between the axes is not permissible on vehicles with different tire sizes or rim sizes on the front and rear axles.

Storing tires

Air pressure

Do not exceed the maximum tire inflation pressure indicated on the side wall of the tire.

Storage

Store wheels and tires in a cool, dry and dark place.

Always protect tires against all contact with oil, grease, and solvents.

Do not leave tires in plastic bags.

Remove dirt from wheels or tires.

Repairing a flat tire

Safety measures

- ▶ Park the vehicle as far away as possible from passing traffic and on solid ground.
- ▶ Switch on the hazard warning system.
- ▶ Secure the vehicle against rolling away by setting the parking brake.
- ▶ Turn the steering wheel until the front wheels are in the straight-ahead position and engage the steering wheel lock.
- ▶ Have all vehicle occupants get out of the vehicle and ensure that they remain outside the immediate area in a safe place, such as behind a guardrail.
- ▶ If necessary, set up a warning triangle at an appropriate distance.

Mobility System

Concept

With the Mobility System, minor tire damage can be sealed temporarily to enable continued travel. To accomplish this, sealant is pumped into the tires, which seals the damage from the inside.

General information

- ▶ Follow the instructions on using the Mobility System found on the compressor and sealant container.
- ▶ Use of the Mobility System may be ineffective if the tire puncture measures approx. 1/8 inches/4 mm or more.
- ▶ Contact a dealer's service center or another qualified service center or repair shop if the tire cannot be made drivable.
- ▶ If possible, do not remove foreign bodies that have penetrated the tire. Only remove foreign objects if they are visibly protruding from the tire.

- ▶ Pull the speed limit sticker off the sealant container and apply it to the steering wheel.
- ▶ The use of a sealant can damage the TPM wheel electronics. In this case, have the TPM wheel electronics replaced at the next opportunity.
- ▶ The compressor can be used to check the tire inflation pressure.

Overview

Storage

The Mobility System is located in the storage compartment under the hood.

Sealant container

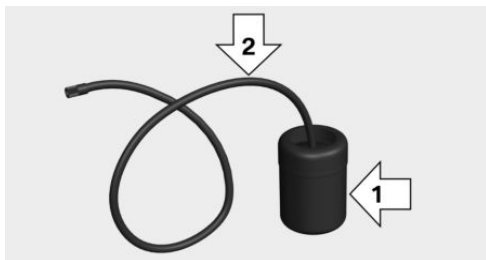

- ▶ Sealant container, arrow 1.
- ▶ Filling hose, arrow 2.

Observe use-by date on the sealant container.

Compressor

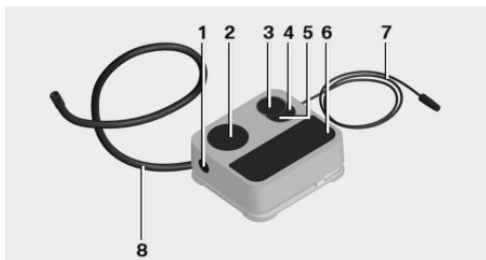

- 1 Sealant container unlocking
- 2 Sealant container holder
- 3 Tire pressure gage

- 4 Reduce tire inflation pressure button
- 5 On/off switch
- 6 Compressor
- 7 Connector/cable for socket
- 8 Connection hose

Filling the tire with sealant

Safety information

DANGER

If the exhaust pipe is blocked or ventilation is insufficient, harmful exhaust gases can enter into the vehicle. The exhaust gases contain pollutants which are colorless and odorless. In enclosed areas, exhaust gases can also accumulate outside of the vehicle. There is danger to life. Keep the exhaust pipe free and ensure sufficient ventilation.

NOTE

The compressor can overheat during extended operation. There is a risk of damage to property. Do not run the compressor for more than 10 minutes.

Filling

1. Shake the sealant container.

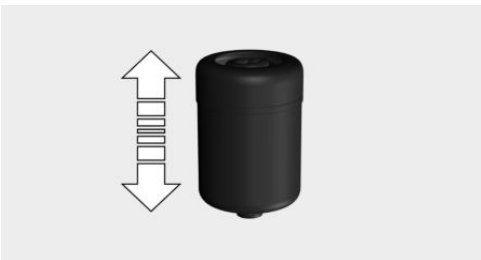

2. Pull filling hose completely out of the cover of the sealant container. Do not kink the hose.

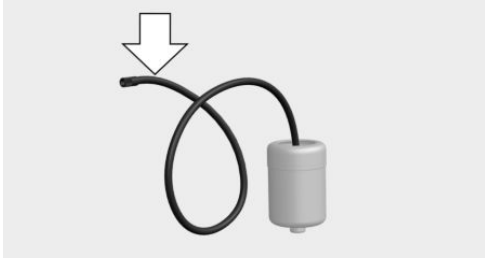

3. Slide the sealant container into the holder on the compressor housing, ensuring that it engages audibly.

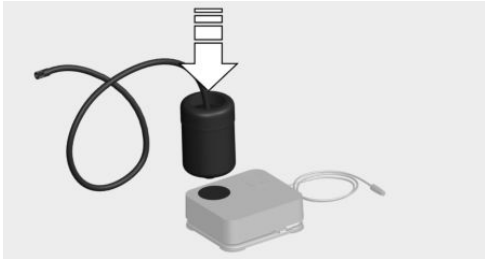

4. Screw the filling hose of the sealant container onto the tire valve of the nonworking wheel.

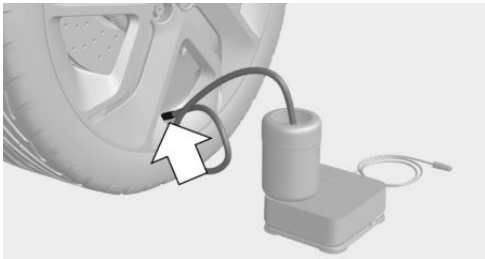

5. With the compressor switched off, insert the plug into the power socket inside the vehicle.

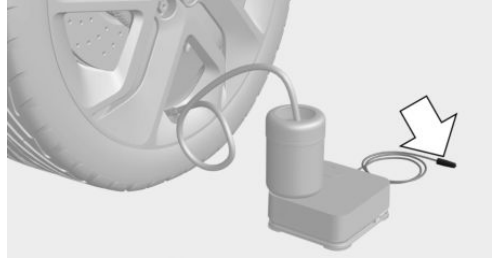

6. With standby state or drive-ready state switched on, switch on the compressor.

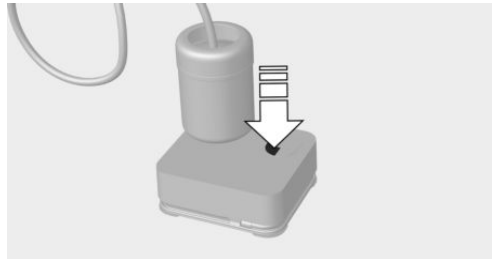

Let the compressor run for max. 10 minutes to fill the tire with sealant and achieve a tire inflation pressure of approx. 2.5 bar.

While the tire is being filled with sealant, the tire inflation pressure may sporadically reach approx. 5 bar. Do not switch off the compressor at this point.

Checking and adjusting the tire inflation pressure

Checking

1. Switch off the compressor.
2. Read the tire inflation pressure on the tire pressure gage.

To continue the trip, a tire inflation pressure of at least 2 bar must be reached.

Removing and stowing the sealant container

1. Unscrew the filling hose of the sealant container from the tire valve.
2. Press the red unlocking device.
3. Remove the sealant container from the compressor.
4. Wrap and store the sealant container in suitable material to avoid dirtying the cargo area.

Minimum tire inflation pressure is not reached

1. Pull the connector out of the power socket inside the vehicle.
2. Drive 33 ft/10 m forward and back to distribute the sealant in the tire.
3. Screw the connection hose of the compressor directly onto the tire valve stem.

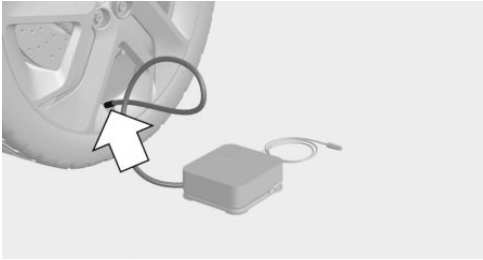

4. Insert the connector into the power socket inside the vehicle.

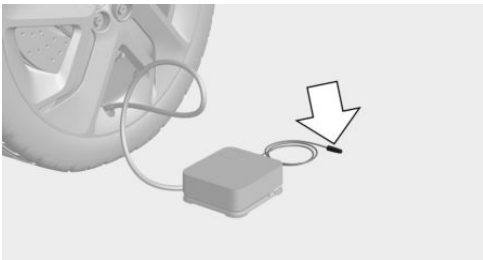

5. With standby state or drive-ready state switched on, switch on the compressor.
If a tire inflation pressure of at least 2 bar cannot be reached, contact your dealer's service

center or another qualified service center or repair shop.

If a tire inflation pressure of at least 2 bar is reached, see Minimum tire inflation pressure is reached.

6. Unscrew the connection hose of the compressor from the tire valve.
7. Pull the connector out of the power socket inside the vehicle.
8. Stow the Mobility System in the vehicle.

Minimum tire inflation pressure is reached

1. Unscrew the connection hose of the compressor from the tire valve.
2. Pull the connector out of the power socket inside the vehicle.
3. Stow the Mobility System in the vehicle.
4. Immediately drive approx. 5 miles/10 km to ensure that the sealant is evenly distributed in the tire.

Do not exceed a speed of 50 mph/80 km/h.

If possible, do not drive at speeds less than 12 mph/20 km/h.

Adjustment

1. Stop at a suitable location.
2. Screw the connection hose of the compressor directly onto the tire valve stem.

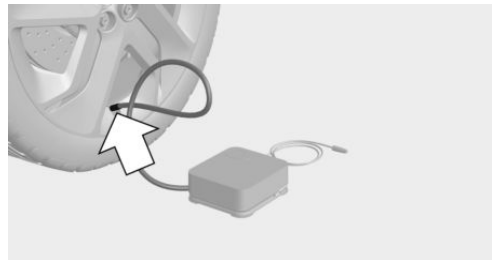

3. Insert the connector into the power socket inside the vehicle.

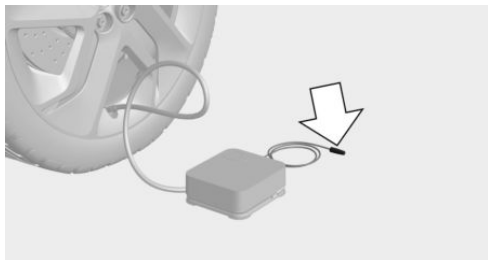

4. Correct the tire inflation pressure to at least 2.0 bar.
 - ▶ Increase tire inflation pressure: with standby state or drive-ready state switched on, switch on the compressor.
 - ▶ To reduce the pressure: press the button on the compressor.
5. Unscrew the connection hose of the compressor from the tire valve.
6. Pull the connector out of the power socket inside the vehicle.
7. Stow the Mobility System in the vehicle.

Continuing the trip

Do not exceed the maximum permissible speed of 50 mph/80 km/h.

Reinitialize the run-flat tires.

Reset the Tire Pressure Monitor TPM.

Replace the nonworking tire and the sealant container of the Mobility System at the next opportunity.

Snow chains

Safety information

WARNING

With the mounting of snow chains on unsuitable tires, the snow chains can come into contact with vehicle parts. There is a risk of accidents or risk of damage to property. Only mount snow chains on tires that are designated by their manufacturer as suitable for the use of snow chains.

WARNING

Insufficiently tight snow chains may damage tires and vehicle components. There is a risk of accidents or risk of damage to property. Make sure that the snow chains are always sufficiently tight. Re-tighten as needed according to the snow chain manufacturer's instructions.

Fine-link snow chains

The manufacturer of your vehicle recommends use of fine-link snow chains. Certain types of fine-link snow chains have been tested by the manufacturer of the vehicle and recommended as road-safe and suitable.

Information regarding suitable snow chains is available from a dealer's service center or another qualified service center or repair shop.

Use

Use only in pairs on the rear wheels, equipped with the tires of the following size:

- ▶ 155/70 R 19.

Follow the snow chain manufacturer's instructions.

Do not initialize the run-flat tires after mounting snow chains, as doing so may result in incorrect readings.

Do not reset the Tire Pressure Monitor TPM after mounting snow chains, as doing so may result in incorrect readings.

When driving with snow chains, briefly activate Dynamic Traction Control DTC, if needed.

Maximum speed with snow chains

Do not exceed a speed of 30 mph/50 km/h when using snow chains.

Changing wheels/tires

General information

When a flat tire kit is used, an immediate wheel change when there is a loss of tire inflation pressure in the event of a flat tire is not always necessary.

If needed, the tools for changing wheels are available as accessories from a dealer's service center or another qualified service center or repair shop.

Safety information

DANGER

The vehicle jack is only provided for short-term lifting of the vehicle for wheel changes. Even if all safety measures are observed, there is a risk of the raised vehicle falling, if the vehicle jack tips over. There is a risk of injuries or danger to life. If the vehicle is raised, do not lie under the vehicle and do not start the engine.

DANGER

Supports such as wooden blocks under the vehicle jack reduce the capacity of the vehicle jack to bear weight. They have the potential to exert too much strain on the vehicle jack, causing it to tip over and the vehicle to fall. There is

a risk of injuries or danger to life. Do not place supports under the vehicle jack.

WARNING

The jack, issued by the vehicle manufacturer, is provided in order to perform a wheel change in the event of a breakdown. The jack is not designed for frequent use; for example, changing from summer to winter tires. Using the jack frequently may cause it to become jammed or damaged. There is a risk of injury and risk of damage to property. Only use the jack to attach an emergency or spare wheel in the event of a breakdown.

WARNING

On soft, uneven or slippery ground, for example snow, ice, tiles, etc., the vehicle jack can slip away. There is a risk of injury. If possible, change the wheel on a flat, solid, and slip-resistant surface.

WARNING

The vehicle jack is optimized for lifting the vehicle and for the jacking points on the vehicle only. There is a risk of injury. Do not lift any other vehicle or cargo using the vehicle jack.

WARNING

If the vehicle jack is not inserted into the jacking point provided for this purpose, the vehicle may be damaged or the vehicle jack may slip when it is being cranked up. There is a risk of injury or risk of damage to property. When cranking up the vehicle jack, ensure that it is inserted in the jacking point next to the wheel housing.

WARNING

A vehicle that is raised on a vehicle jack may fall off of the jack if lateral forces are exerted on it. There is a risk of injury and risk of damage to property. While the vehicle is raised, do not exert lateral forces on the vehicle or pull abruptly on the vehicle. Have a stuck wheel removed by a dealer's service center or another qualified service center or repair shop.

Securing the vehicle against rolling

General information

The vehicle manufacturer recommends to additionally secure the vehicle against rolling away when changing a wheel.

On a level surface

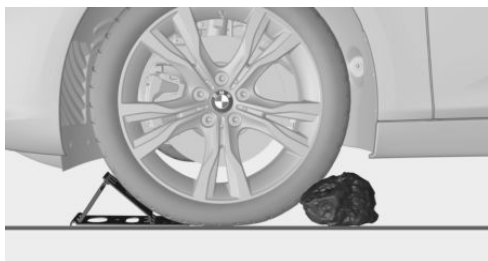

Place chocks or other suitable objects, for example a rock, in front of and behind the wheel that is diagonally opposite to the wheel that you wish to change.

On a slight downhill gradient

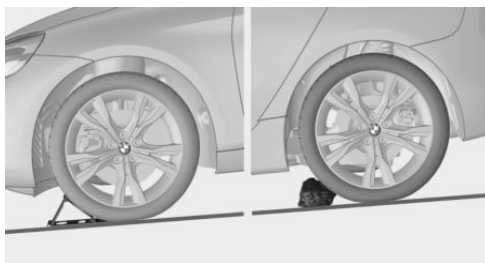

If you need to change a wheel on a slight downhill grade, place chocks and other suitable objects, for instance a rock, under the wheels of both the front and rear axles against the rolling direction.

Lug bolt lock

Concept

The wheel lug bolts have a special coding. The lug bolts can only be released with the adapter which matches the coding.

Overview

The adapter of the lug bolt lock is in the onboard vehicle tool kit or in a storage compartment close to the onboard vehicle tool kit.

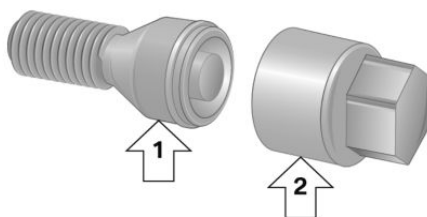

- ▶ Lug bolt, arrow 1.
- ▶ Adapter, arrow 2.

Unscrewing

1. Attach the adapter to the lug bolt.
2. Unscrew the lug bolt.

3. Remove the adapter after unscrewing the lug bolt.

Screwing on

1. Attach the adapter to the lug bolt. If necessary, turn the adapter until it fits on the lug bolt.
2. Screw on the lug bolt. The tightening torque is 140 Nm.
3. Remove the adapter and stow it after screwing on the lug bolt.

Preparing the vehicle

- ▶ Park the vehicle on solid and non-slip ground at a safe distance from traffic.
- ▶ Switch on the hazard warning system.
- ▶ Set the parking brake.
- ▶ Engage a gear or move the selector lever to position P.
- ▶ As soon as permitted by the traffic flow, have all vehicle occupants get out of the vehicle and ensure that they remain outside the immediate area in a safe place, such as behind a guardrail.
- ▶ Depending on the vehicle equipment, get wheel change tools and, if necessary, the emergency wheel from the vehicle.
- ▶ If necessary, set up a warning triangle or portable hazard warning light at an appropriate distance.
- ▶ Secure the vehicle additionally against rolling.
- ▶ Loosen the lug bolts a half turn.

Jacking points for the vehicle jack

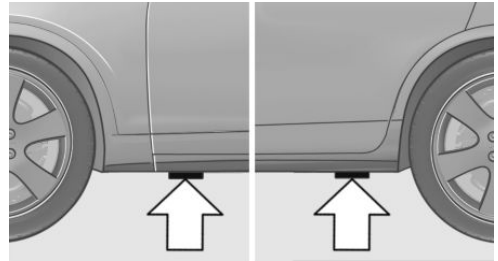

The jacking points for the vehicle jack are located at the indicated positions.

Jacking up the vehicle

WARNING

Hands and fingers can be jammed when using the vehicle jack. There is a risk of injury. Comply with the described hand position and do not change this position while using the vehicle jack.

1. Hold the vehicle jack with one hand, arrow 1, and grasp the vehicle jack crank with your other hand, arrow 2.

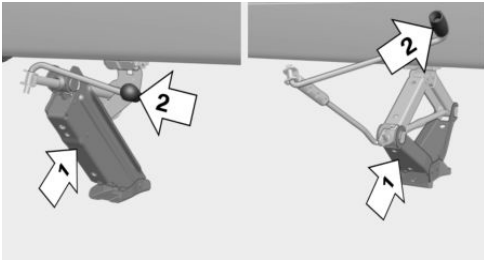

2. Insert the vehicle jack into the rectangular recess of the jacking point closest to the wheel to be changed.

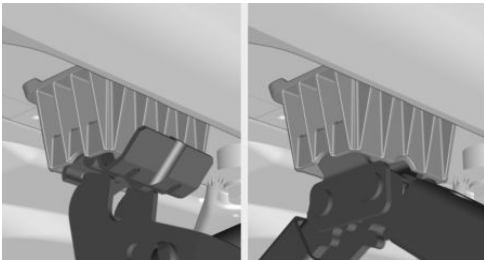

3. Extend the vehicle jack by turning the vehicle jack crank or lever clockwise.

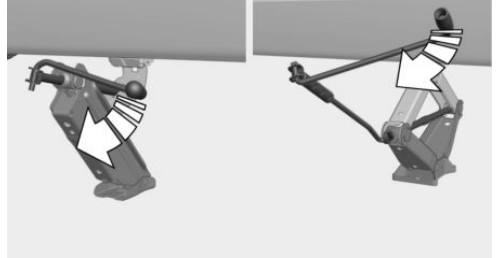

4. Take your hand away from the vehicle jack as soon as the vehicle jack is under load and continue turning the vehicle jack crank or lever with one hand.
5. Make sure that the vehicle jack foot stands vertically and at a right angle beneath the jacking point.

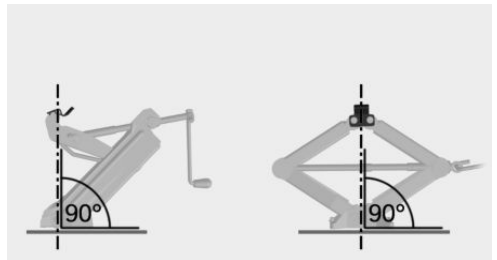

6. Make sure that the vehicle jack foot stands vertically and perpendicularly beneath the jacking point after extending the vehicle jack.

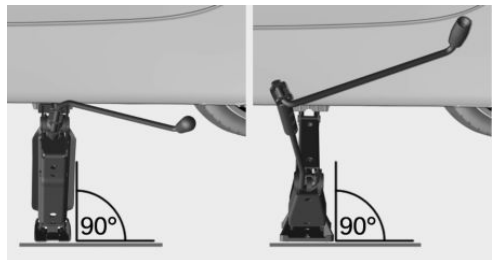

7. Crank up the vehicle jack until the entire surface of the jack is in contact with the ground and the wheel in question is raised a maximum of 1.2 inches/3 cm off the ground.

Mounting a wheel

Mount one emergency wheel only, as required.

1. Unscrew the lug bolts.
2. Remove the wheel.
3. Put the new wheel or emergency wheel on and screw in at least two lug bolts in a crosswise pattern until hand-tight.

If non-original light-alloy wheels of the vehicle manufacturer are mounted, the accompanying lug bolts may have to be used as well.

4. Hand-tighten the remaining lug bolts and tighten all lug bolts well in a crosswise pattern.
5. Turn the vehicle jack crank counterclockwise to retract the vehicle jack and lower the vehicle.
6. Remove the vehicle jack and stow it securely.

After the wheel change

1. Tighten the lug bolts crosswise. The tightening torque is 101 lb ft/140 Nm.
2. Stow the nonworking wheel in the cargo area, if necessary.

The nonworking wheel cannot be stored under the cargo floor panel because of its size.

3. Check tire inflation pressure at the next opportunity and correct as needed.
4. Reinitialize the run-flat tires.
Reset the Tire Pressure Monitor TPM.
5. Check to make sure the lug bolts are tight with a calibrated torque wrench.
6. Have the damaged tire replaced at the nearest dealer's service center or another qualified service center or repair shop.

Under the hood

Vehicle features and options

This chapter describes all standard, country-specific and optional features offered with the series. It also describes features that are not necessarily

available in your vehicle, e. g., due to the selected options or country versions. This also applies to safety-related functions and systems. When using these functions and systems, the applicable laws and regulations must be observed.

Overview

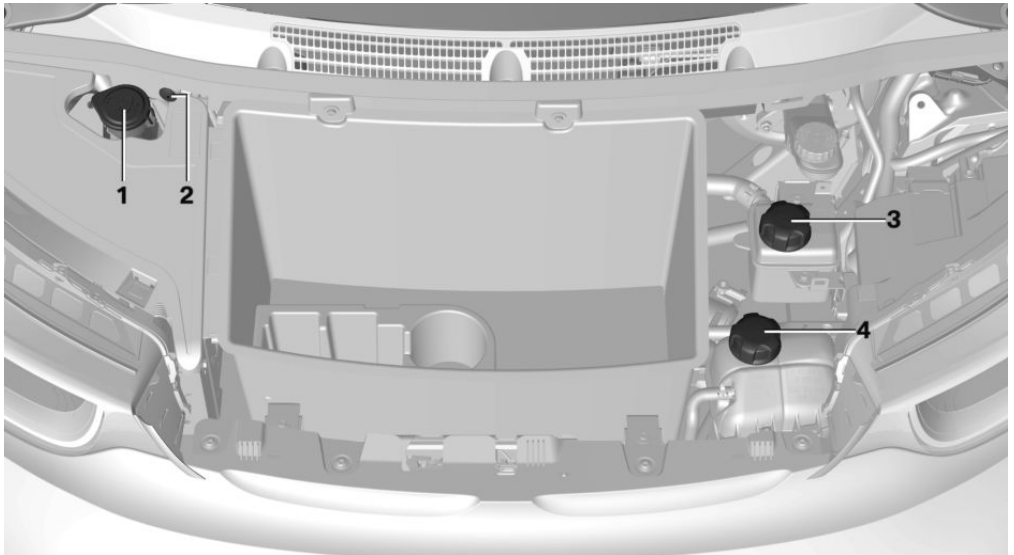

- | | |
|---|--|
| 1 Washer fluid reservoir | 3 Climate control coolant reservoir |
| 2 With Range Extender: filler flap emergency unlocking | 4 Drive coolant reservoir |

The charging cable compartment in the center is used for storage of the charging cables.

Moisture can penetrate into the charging cable compartment, for instance in a vehicle wash.

Hood

Safety information

WARNING

Improperly executed work under the hood can damage components and lead to a safety risk. There is a risk of accidents or risk of damage to property. The manufacturer of your vehicle recommends that work under the hood be performed only by an authorized BMW i dealer's service center or another qualified service center or repair shop.

NOTE

Folded-away wipers can be jammed when the hood is opened. There is a risk of damage to property. Make sure that the wipers with the wiper blades mounted are folded down onto the windshield before opening the hood.

Opening hood

Unlock hood

-  Press button on the remote control or in the driver's floor area, refer to page 78.

Opening hood

- Press the release handle and open the hood.

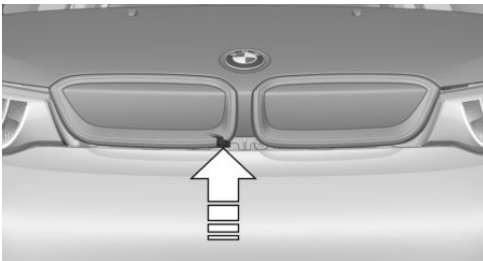

Indicator/warning lights

When the hood is opened, a Check Control message is displayed.

Closing the hood

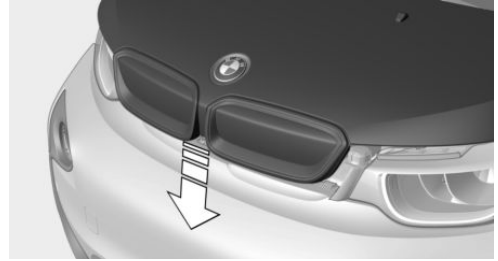

From approx. 16 inches/40 cm height allow to fall and press again to lock the hook completely.

Make sure you hear the hood engage.

WARNING

An incorrectly locked hood can open while driving and restrict visibility. There is a risk of an accident. Stop immediately and correctly close the hood.

WARNING

Body parts can be jammed when opening and closing the hood. There is a risk of injury. Make sure that the area of movement of hood is clear during opening and closing.

Engine oil

Vehicle features and options

This chapter describes all standard, country-specific and optional features offered with the series. It also describes features that are not necessarily available in your vehicle, e. g., due to the selected options or country versions. This also applies to safety-related functions and systems. When using these functions and systems, the applicable laws and regulations must be observed.

General information

Engine oil consumption depends on the frequency of Range Extender use. Therefore, regularly check the engine oil level after refueling.

Safety information

NOTE

An engine oil level that is too low causes engine damage. There is a risk of damage to property. Immediately add engine oil.

NOTE

Too much engine oil can damage the engine or the catalytic converter. There is a risk of damage to property. Do not add too much engine oil. When too much engine oil is added, have the engine oil level corrected by a dealer's service center or another qualified service center or repair shop.

Checking the oil level

General information

Check the engine oil level with Range Extender warmed up to operating temperature.

After switching off the Range Extender, wait several minutes before checking the oil level so that the engine oil can collect in the oil pan.

Checking

1. Park the vehicle in horizontal position in a safe place.
2. Switch the engine off.
3. Remove the cargo floor panel.

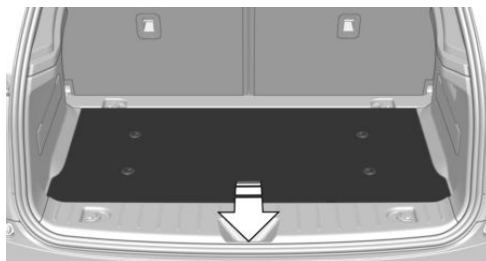

4. Turn the lid counterclockwise and remove.



- After approx. 5, minutes, remove the dip stick and wipe with a lint-free cloth, paper towel or similar.

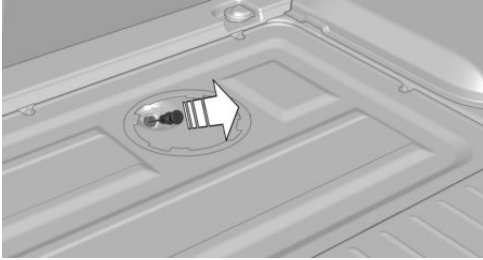

- Carefully insert the dipstick up to the stop in the measuring tube, and pull it back out.
The engine oil level must be between the two marks of the dipstick.

Electronic oil measurement

General information

The electronic oil measurement has two measuring principles:

- ▷ Monitoring.
- ▷ Detailed measurement.

When making frequent short-distance trips or using a dynamic driving style, for instance when taking curves aggressively, regularly perform a detailed measurement.

Monitoring

Concept

The engine oil level is monitored electronically while driving and can be shown on the Control Display.

If the engine oil level is outside its permissible operating range, a Check Control message is displayed.



A red indicator light indicates that the engine oil pressure is too low.

Functional requirements

A current measured value is available after approx. 30 minutes of normal driving.

Displaying the engine oil level

Via iDrive:

- "My Vehicle"
- "Vehicle status"
-  "Engine oil level"

The engine oil level is displayed.

System limits

When making frequent short-distance trips or using a dynamic driving style, it may not be possible to calculate a measured value. In this case, the measured value for the last, sufficiently long trip is displayed.

Detailed measurement

Concept

The engine oil level is checked when the vehicle is stationary and displayed via a scale.

If the engine oil level is outside its permissible operating range, a Check Control message is displayed.

General information

During the measurement, the idle speed is increased somewhat.

Functional requirements

- ▷ Vehicle is parked in a horizontal position.
- ▷ Engine is running and is at operating temperature.

Performing a detailed measurement

Via iDrive:

- "My Vehicle"
- "Vehicle status"



3. : "Engine oil level"
4. "Measure engine oil level"
5. "Start measurement"

The engine oil level is checked and displayed via a scale.

Adding or changing engine oil

Have engine oil added or changed by a dealer's service center or another qualified service center or repair shop if necessary.

Coolant

Vehicle features and options

This chapter describes all standard, country-specific and optional features offered with the series. It also describes features that are not necessarily available in your vehicle, e. g., due to the selected options or country versions. This also applies to safety-related functions and systems. When using these functions and systems, the applicable laws and regulations must be observed.

General information

Coolant consists of water and additives.

The vehicle's cooling circuits are filled with different types of coolant. Do not mix the different types of coolant.

Not all commercially available additives are suitable for the vehicle. Information about suitable additives is available from a dealer's service center or another qualified service center or repair shop.

Safety information

WARNING

With the engine hot and the cooling system open, coolant can escape and lead to scalding. There is a risk of injury. Only open the cooling system with the engine cooled down.

WARNING

Additives are harmful and incorrect additives can damage the engine. There is a risk of injury and risk of damage to property. Do not allow additives to come into contact with skin, eyes

or articles of clothing. Use suitable additives only.

Coolant reservoir

The vehicle has two coolant reservoirs that are located under the hood.

To ensure the operational reliability of the vehicle, always check the coolant level of both coolant reservoirs.

Opening the hood, refer to page [243](#).

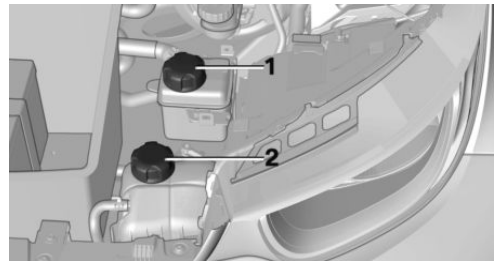

- 1 Climate control coolant reservoir
- 2 Drive coolant reservoir

Coolant level

Climate control coolant reservoir

Checking

1. Allow the air conditioner to cool down.

- Turn the lid of the coolant reservoir slightly counterclockwise to allow any excess pressure to dissipate, then open it.

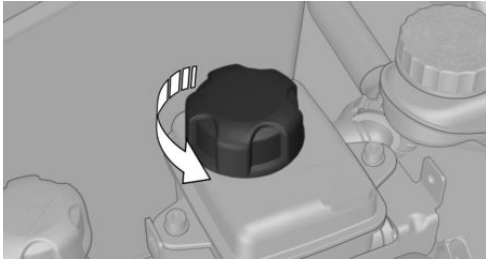

- Check the coolant level.
The coolant level is correct if it lies between the minimum and maximum marks in the reservoir.

Adding

- Slowly add coolant up to the specified level; do not overfill.
- Close the cap.
- Have cause of the coolant loss eliminated by a dealer's service center or another qualified service center or repair shop as quickly as possible.

Drive coolant reservoir

Checking

- Allow the drive to cool down.
- Check the coolant level.

The marks are on the side of the coolant reservoir. The coolant level is correct if it lies between the minimum and maximum marks.

Adding

- Turn the lid of the coolant reservoir slightly counterclockwise to allow any excess pressure to dissipate, then open it.

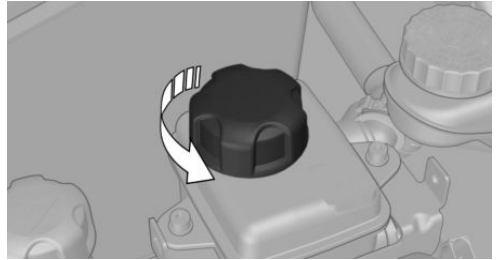

- Slowly add coolant up to the specified level; do not overfill.
- Close the cap.
- Have cause of the coolant loss eliminated by a dealer's service center or another qualified service center or repair shop as quickly as possible.

Disposal



Comply with the relevant environmental protection regulations when disposing of coolant and coolant additives.

Maintenance

Vehicle features and options

This chapter describes all standard, country-specific and optional features offered with the series. It also describes features that are not necessarily available in your vehicle, e. g., due to the selected options or country versions. This also applies to safety-related functions and systems. When using these functions and systems, the applicable laws and regulations must be observed.

BMW maintenance system

The maintenance system indicates required maintenance measures, and thereby provides support in maintaining road safety and the operational reliability of the vehicle.

In some cases, scopes and intervals of the maintenance system may vary according to the country version. Replacement work, spare parts, fuels and lubricants, and wear materials are calculated separately. Further information is available from a dealer's service center or another qualified service center or repair shop.

Safety information

DANGER

Improperly executed work, in particular maintenance and repair on the high-voltage system, can lead to electric shock. There is a risk of injury, fire and danger to life.

The manufacturer of your vehicle recommends that the work on the vehicle, in particular maintenance and repair, be performed only by an authorized BMW i dealer's service center or another qualified service center or repair shop.

Condition Based Service CBS

Concept

Sensors and special algorithms take into account the driving conditions of the vehicle. CBS uses these to calculate the need for maintenance.

The system makes it possible to adapt the amount of maintenance corresponding to your user profile.

General information

Information on service requirements, refer to page 123, can be displayed on the Control Display.

Service data in the remote control

Information on the required maintenance is continuously stored in the remote control. The dealer's service center can read this data out and suggest a maintenance scope for the vehicle.

Therefore, hand the service advisor the remote control with which the vehicle was driven most recently.

Storage periods

Storage periods during which the vehicle battery was disconnected are not taken into account.

If this occurs, have a dealer's service center or another qualified service center or repair shop update the time-dependent maintenance procedures, such as checking brake fluid and, if necessary, changing the engine oil and the microfilter/activated-charcoal filter.

Service and Warranty Information Booklet for US models and Warranty and Service Guide Booklet for Canadian models

Please consult your Service and Warranty Information Booklet for US models and Warranty and Service Guide Booklet for Canadian models for additional information on service requirements.

The manufacturer of your vehicle recommends that maintenance and repair be performed by a dealer's service center or another qualified service center or repair shop. Records of regular maintenance and repair work should be retained.

Socket for OBD Onboard Diagnosis

General information

Devices connected at the OBD socket trigger the alarm system when the vehicle is locked. Remove any devices connected at the OBD socket before locking the vehicle.

Safety information

NOTE

The socket for Onboard Diagnosis is an intricate component intended to be used in conjunction with specialized equipment to check the vehicle's primary emissions system. Improper use of the socket for Onboard Diagnosis, or contact with the socket for Onboard Diagnosis for other than its intended purpose, can cause vehicle malfunctions and creates risks of personal and property damage. Given the foregoing, the manufacture of your vehicle strongly recommends that access to the socket for Onboard Diagnosis be limited to a dealer's service center or another qualified service cen-

ter or repair shop or other persons that have the specialized training and equipment for purposes of properly utilizing the socket for Onboard Diagnosis.

Position

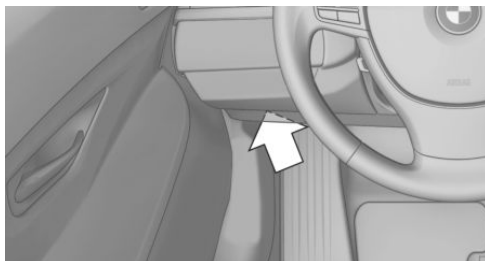

Located on the driver's side is an OBD socket for reading the vehicle data.

On vehicles with Range Extender, additional components are checked that are critical for its emissions mix.

Emissions

Applies to vehicles with Range Extender.



- ▶ The warning light lights up: Emissions are deteriorating. Have the vehicle checked as soon as possible.
- ▶ The warning light flashes under certain circumstances:

This indicates that there is excessive misfiring in the engine.

Reduce the vehicle speed and have the system checked immediately; otherwise, serious engine misfiring within a brief period can seriously damage emission control components, in particular the catalytic converter.

Replacing components

Vehicle features and options

This chapter describes all standard, country-specific and optional features offered with the series. It also describes features that are not necessarily available in your vehicle, e. g., due to the selected options or country versions. This also applies to safety-related functions and systems. When using these functions and systems, the applicable laws and regulations must be observed.

Wiper blades

Safety information

NOTE

The window may sustain damage if the wiper falls onto it without the wiper blade installed. There is a risk of damage to property. Hold the wiper firmly when changing the wiper blade. Do not fold or switch on the wiper without a wiper blade installed.

Replacing the front wiper blades

1. To change the wiper blades, fold up the wiper arms, refer to page 112.
2. Fold up the wipers.

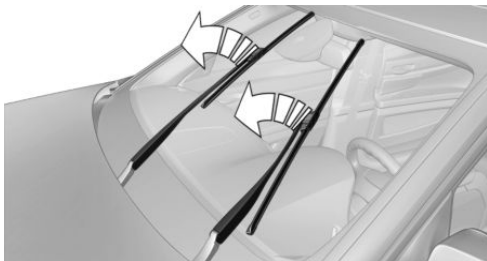

3. Position the wiper blade in a horizontal position.

4. Remove the wiper blade toward one side.

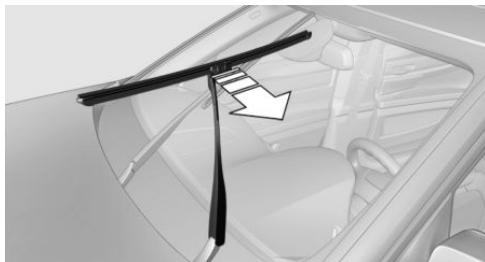

5. Insert the new wiper blade in reverse order of removal until it locks in place.
6. Fold down the wipers.

Replacing the rear wiper blade

1. Fold up the wiper arm.
2. Turn the wiper blade all the way back.

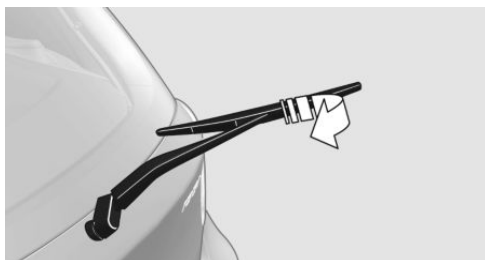

3. Continue turning the wiper blade all the way so that it pops out of the holder.
4. Press the new wiper blade into the holder until you hear it snap into place.
5. Fold the wipers in.

Light/bulb replacement

General information

Lights and bulbs

Lights and bulbs make an essential contribution to vehicle safety.

All headlights and lights are made using LED technology.

The vehicle manufacturer recommends that you have the relevant work carried out a dealer's service center or another qualified service center or repair shop.

Follow the safety information, refer to page 252.

Light-emitting diodes (LEDs)

The lights use light-emitting diodes installed behind the cover as a light source. These light-emitting diodes are related to conventional lasers and are officially designated as Class 1 light-emitting diodes.

Safety information

Light-emitting diodes (LEDs)

WARNING

Intensive brightness can irritate or damage the retina of the eye. There is a risk of injury. Do not look directly into the headlights or other light sources. Do not remove the LED covers.

Headlight glass

Condensation can form on the inside of the external lights in cool or humid weather. When driving with the lights switched on, the condensation evaporates after a short time. The headlight glass does not need to be changed.

If despite driving with the headlights switched on, increasing humidity forms, for instance water

droplets in the light, have the headlights checked.

Vehicle battery

The vehicle battery has 12 volts. The battery supplies the onboard electronics with energy.

Information about the high-voltage system, refer to page 210.

Maintenance

The battery is maintenance-free.

The added amount of acid is sufficient for the service life of the battery.

More information about the battery can be requested from a dealer's service center or another qualified service center or repair shop.

Replacing the vehicle battery

General information

The manufacturer of your vehicle recommends that you have a dealer's service center or another qualified service center or repair shop register the vehicle battery to the vehicle after the battery has been replaced. Once the battery has been registered again, all comfort features will be available without restriction and any Check Control messages displayed which relate to comfort features will disappear.

Safety information

NOTE

Vehicle batteries that are not compatible can damage vehicle systems and impair vehicle functions. There is a risk of personal and property damage. Only vehicle batteries that are compatible with your vehicle type should be installed in your vehicle. Information on compatible vehicle batteries is available at your dealer's service center.

Charging the vehicle battery

General information

Charging a discharged battery, refer to page 220.

Safety information

NOTE

Non-compatible external chargers can damage the vehicle. There is a risk of personal and property damage. Only charging devices that are compatible with your vehicle and that are below the maximum charge voltage should be used to charge your vehicle. Information on compatible chargers is available at your dealer's service center.

Power failure

After a power loss, some equipment needs to be newly initialized or individual settings updated, for example:

- ▶ Time: update.
- ▶ Date: update.
- ▶ Glass sunroof and sun protection: initialize the system.

Disposing of old batteries



Have old batteries disposed of by a dealer's service center or another qualified service center or repair shop or take them to a collection point.

Maintain the battery in an upright position for transport and storage. Secure the battery so that it does not tip over during transport.

Fuses

Safety information

WARNING

Incorrect and repaired fuses can overload electrical lines and components. There is a risk of fire. Never attempt to repair a blown fuse. Do not replace a nonworking fuse with a substitute of another color or amperage rating.

Accessing the fuses

The fuses are located in the passenger floor area under the dashboard.

1. To open, loosen screws, arrow 1.

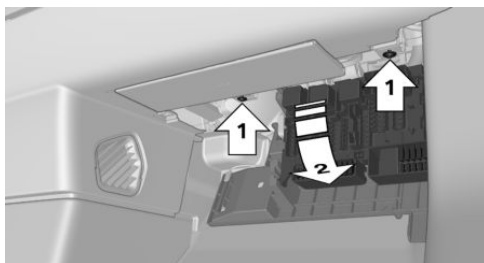

2. Fold down the fuse holder, arrow 2.

Proceed in the reverse order to install.

Information on the fuse types and locations, as well as the positions of any other fuse boxes, is found on a separate sheet in the fuse box.

Replacing fuses

The vehicle manufacturer recommends that you have a dealer's service center or another qualified service center or repair shop replace the fuses.

Breakdown assistance

Vehicle features and options

This chapter describes all standard, country-specific and optional features offered with the series. It also describes features that are not necessarily available in your vehicle, e. g., due to the selected options or country versions. This also applies to safety-related functions and systems. When using these functions and systems, the applicable laws and regulations must be observed.

Hazard warning flashers



The button is located in the center console.

The red light in the button flashes when the hazard warning flashers are activated.

Warning triangle

The warning triangle is located in the hood.

First-aid kit

General information

Some of the articles have a limited service life. Check the expiration dates of the contents regularly and replace any expired items promptly.

Storage

The first-aid kit is located at the rear of the cargo area.

Emergency Request

Intelligent emergency call

Concept

In case of an emergency, an Emergency Request can be triggered automatically by the system or manually.

Intelligent emergency call establishes a connection with the BMW Response Center.

General information

Only press the SOS button in an emergency.

For technical reasons, the Emergency Request cannot be guaranteed under unfavorable conditions.

Overview



SOS button in the roofliner.

Functional requirements

- ▶ The Assist system is functional.
- ▶ The ignition is switched on.

- ▶ If the vehicle is equipped with intelligent emergency call: the SIM card integrated in the vehicle has been activated.

Automatic triggering

Under certain conditions, for instance if the airbags trigger, an Emergency Request is automatically initiated immediately after an accident of corresponding severity. Automatic Collision Notification is not affected by pressing the SOS button.

Manual triggering

1. Touch the cover.
 2. Press and hold the SOS button until the LED on the button illuminates green.
- ▶ The LED is illuminated green when an Emergency Request has been initiated.

If a cancel prompt appears on the Control Display, the Emergency Request can be aborted.

If the situation allows, wait in your vehicle until the voice connection has been established.

- ▶ The LED flashes green when a connection to the BMW Response Center has been established.

The BMW Response Center then makes contact with you and takes further steps to help you.

Even if you are unable to respond, the BMW Response Center can take further steps to help you under certain circumstances.

For this, data is transmitted to the BMW Response Center which serves to determine the necessary rescue measures. E.g., the current position of the vehicle, if it can be established.

Even if you can no longer hear the BMW Response Center through the loudspeakers, the BMW Response Center may still be able to hear you.

The BMW Response Center ends the Emergency Request.

Jump-starting

DANGER

Due to the high voltage of the drive system, there is a risk of electric shock. There is danger to life. Do not jump or directly charge the vehicle battery with conventional jump-starting.

Towing

Transporting the vehicle

General information

The vehicle is not permitted to be towed.

Safety information

NOTE

The vehicle can be damaged when towing the vehicle with a single lifted axle. There is a risk of damage to property. The vehicle should only be transported on a loading platform.

Pushing the vehicle

To remove a broken-down vehicle from the danger area, push it for a short distance at a speed of no more than 6 mph/10 km/h.

Roll or push, refer to page 103, the vehicle.

Tow truck

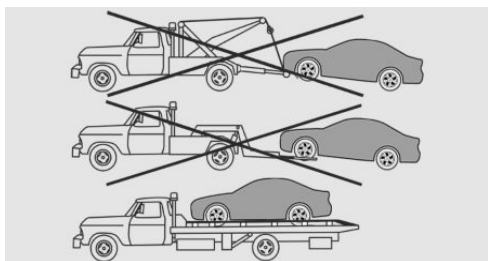

The vehicle should only be transported on a loading platform.

NOTE

The vehicle can become damaged when lifting and securing it.

There is a risk of damage to property.

- ▷ Lift the vehicle using suitable means.
- ▷ Do not lift or secure the vehicle by its tow fitting, body parts, or suspension parts.

Towing other vehicles

General information

Switch on the hazard warning system, depending on local regulations.

If the electrical system has failed, clearly identify the vehicle being towed by placing a sign or a warning triangle in the rear window.

Safety information

WARNING

If the approved gross vehicle weight of the towing vehicle is lighter than the vehicle to be towed, the tow fitting can tear off or it will not be possible to control the vehicle's response. There is a risk of an accident! Make sure that the gross vehicle weight of the towing vehicle is heavier than the vehicle to be towed.

NOTE

If the tow bar or tow rope is attached incorrectly, damage to other vehicle parts can occur. There is a risk of damage to property. Correctly attach the tow bar or tow rope to the tow fitting.

Tow bar

The tow fittings used should be on the same side on both vehicles.

Should it prove impossible to avoid mounting the tow bar at an offset angle, please follow the following:

- ▷ Maneuvering capability is limited going around corners.
- ▷ The tow bar will generate lateral forces if it is secured with an offset.

Tow rope

When starting to tow the vehicle, make sure that the tow rope is taut.

Use nylon ropes or straps, which will enable the vehicle to be towed without jerking.

Tow fitting

General information

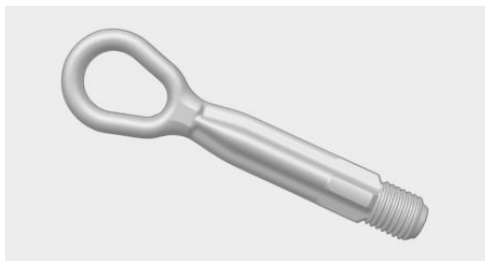

The screw-in tow fitting should always be carried in the vehicle.

The tow fitting can be screwed in at the front or rear of the vehicle.

The tow fitting is located in the storage compartment under the hood.

Use of the tow fitting:

- ▶ Use only the tow fitting provided with the vehicle and screw it all the way in.
- ▶ Use the tow fitting for towing on paved roads only.
- ▶ Avoid lateral loading of the tow fitting, for instance do not lift the vehicle by the tow fitting.

Safety information

NOTE

If the tow fitting is not used as intended, there may be damage to the vehicle or to the tow fitting. There is a risk of damage to property. Follow the notes on using the tow fitting.

Screw thread for tow fitting

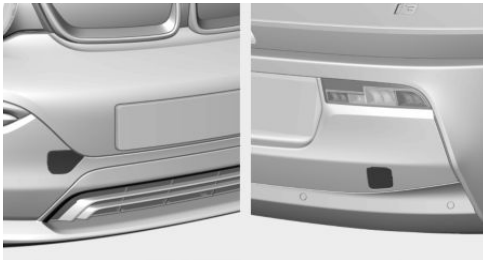

Press on the mark on the edge of the cover to push it out.

What to do after an accident

Safety information

WARNING

Contact with live components can lead to an electric shock. There is a risk of injuries or danger to life. After an accident, do not touch any high-voltage components such as orange colored high-voltage cables or parts that are in contact with exposed high-voltage cables.

WARNING

Fluids in the high-voltage battery are corrosive. There is a risk of injury. Do not touch fluids escaping from the high-voltage battery.

General information

After an accident, compliance with the following safety precautions is required with regard to the high-voltage system:

- ▶ Secure the crash site.
- ▶ Immediately notify rescue forces, police, or firefighters of the fact that your vehicle is equipped with a high-voltage system.
- ▶ Engage selector lever position P, set the parking brake, and switch off the standby state and drive-ready state.
- ▶ Lock the vehicle after exiting.
- ▶ Do not inhale any gases escaping from the high-voltage battery; if needed, maintain a safe distance from the vehicle.

Care

Vehicle features and options

This chapter describes all standard, country-specific and optional features offered with the series. It also describes features that are not necessarily available in your vehicle, e. g., due to the selected options or country versions. This also applies to safety-related functions and systems. When using these functions and systems, the applicable laws and regulations must be observed.

Washing the vehicle

General information

Regularly remove foreign objects such as leaves in the area below the windshield when the hood is raised.

Wash your vehicle frequently, particularly in winter. Intense soiling and road salt can damage the vehicle.

Steam blaster and high-pressure washer

Safety information

NOTE

When washing, water can get into the open charging socket. There is a risk of damage to property. Close the charging socket flap while washing.

WARNING

Contact with live components can lead to an electric shock. High voltage is applied at the charging connection. There is a risk of injury or danger to life.

The manufacturer of your vehicle recommends that work on the charging connection, for instance cleaning, be performed only by an authorized BMW i dealer's service center or another qualified service center or repair shop.

NOTE

When cleaning with high-pressure washers, components can be damaged due to the pressure or temperatures being too high. There is a risk of damage to property. Maintain sufficient distance and do not spray too long continuously. Follow the operating instructions for the high-pressure washer.

Distances and temperature

- ▶ Maximum temperature: 140 °F/60 °C.
- ▶ Minimum distance from sensors, cameras, seals: 12 inches/30 cm.
- ▶ Minimum distance from the charging socket flap: 31.5 in/80 cm.

Automatic vehicle washes

Safety information

NOTE

Water can penetrate in the windshield area due to high-pressure washers. There is a risk of damage to property. Avoid high-pressure washers.

NOTE

Improper use of automatic vehicle washes can cause damage to the vehicle. There is a risk of damage to property. Follow the following instructions:

- ▷ Give preference to cloth vehicle washes or those that use soft brushes in order to avoid paint damage.
- ▷ Avoid vehicle washes with guide rails higher than 4 in/10 cm to avoid damage to the chassis.
- ▷ Observe the tire width of the guide rail to avoid damage to tires and rims.
- ▷ Fold in exterior mirrors to avoid damage to the exterior mirrors.
- ▷ Unscrew the rod antenna to avoid the rod antenna breaking off.
- ▷ Deactivate the wiper and, if necessary, rain sensor to avoid damage to the wiper system.

Driving into a vehicle wash

General information

In a vehicle wash, the vehicle must be able to roll freely.

Roll or push the vehicle, refer to page [103](#).

Some vehicle washes do not permit persons in the vehicle. The vehicle cannot be locked from the outside when in selector lever position N. A signal sounds when an attempt is made to lock the vehicle.

Driving out of a vehicle wash

Make sure that the remote control is in the vehicle.

Activate drive-ready state. Activate drive-ready state, refer to page [101](#).

Headlights

Do not rub wet headlights dry and do not use abrasive or acidic cleaning agents.

Soak areas that have been dirtied, for instance from insects, with shampoo and wash off with water.

Thaw ice with de-icing spray; do not use an ice scraper.

After washing the vehicle

After washing the vehicle, apply the brakes briefly to dry them; otherwise, braking action can be reduced. The heat generated during braking dries brake discs and brake pads and protects them against corrosion.

Completely remove all residues on the windows, to minimize loss of visibility due to smearing and to reduce wiper noises and wiper blade wear.

Vehicle care

Vehicle care products

General information

The manufacturer of your vehicle recommends using care and cleaning products for BMW i. Suitable care products are available from a dealer's service center or another qualified service center or repair shop.

Safety information

WARNING

Cleansers can contain substances that are dangerous and harmful to your health. There is a risk of injury. When cleaning the interior, open the doors or windows. Only use products intended for cleaning vehicles. Follow the instructions on the container.

Vehicle paint

General information

Regular care contributes to driving safety and value retention. Environmental influences in areas with elevated air pollution or natural contaminants, such as tree resin or pollen can affect the vehicle's paintwork. Tailor the frequency and extent of your vehicle care to these influences.



Aggressive substances such as spilled fuel, oil, grease or bird droppings, must be removed immediately to prevent the finish from being altered or discolored.

Matte finish

Only use cleaning and care products suitable for vehicles with matte finish.

Leather care

Remove dust from the leather regularly, using a cloth or vacuum cleaner.

Otherwise, particles of dust and road grime chafe in pores and folds, and lead to increased wear and premature degradation of the leather surface.

To guard against discoloration, such as from clothing, clean leather and provide leather care roughly every two months.

Clean light-colored leather more frequently because soiling on such surfaces is substantially more visible.

Use leather care products; otherwise, dirt and grease will gradually break down the protective layer of the leather surface.

Upholstery material care

General information

Vacuum the upholstery regularly with a vacuum cleaner.

If upholstery is very dirty, for instance with beverage stains, use a soft sponge or microfiber cloth with a suitable cleaning agent.

Clean the upholstery down to the seams using large sweeping motions. Avoid rubbing the material vigorously.

Safety information

NOTE

Open Velcro® fasteners on articles of clothing can damage the seat covers. There is a risk of damage to property. Ensure that any Velcro® fasteners are closed.

Caring for special components

Light-alloy wheels

When cleaning the vehicle, use only neutral wheel cleaners having a pH value from 5 to 9. Do not use abrasive cleaning agents or steam jets above 140 °F/60 °C. Follow the manufacturer's instructions.

Aggressive, acidic or alkaline cleaning agents can destroy the protective layer of adjacent components, such as the brake disc.

After cleaning, apply the brakes briefly to dry them. The heat generated during braking dries brake discs and brake pads and protects them against corrosion.

Chrome surfaces

Carefully clean components such as the radiator grille or door handles with an ample supply of water, possibly with shampoo added, particularly when they have been exposed to road salt.

Rubber components

Environmental influences can cause surface soiling of rubber parts and a loss of gloss. Use only water and suitable cleaning agents for cleaning.

Treat especially worn rubber parts with rubber care agents at regular intervals. When cleaning rubber seals, do not use any silicon-containing vehicle care products in order to avoid damage or noises.

Fine wood parts

Clean fine wood facing and fine wood components only with a suitable care product.

Kenaf

Only treat parts made of Kenaf fibers, for instance in the door trims, using suitable care products.

Plastic components

NOTE

Cleaners that contain alcohol or solvents, such as lacquer thinners, heavy-duty grease removers, fuel, or such, can damage plastic parts. There is a risk of damage to property. Clean with a microfiber cloth. Dampen cloth lightly with water.

Plastic components are e.g.:

- ▶ Imitation leather surfaces.
- ▶ Roofliner.
- ▶ Light lenses.
- ▶ Instrument cluster cover.
- ▶ Matt black spray-coated components.
- ▶ Painted parts in the car's interior.
- ▶ Carbon parts in the car's interior.

Clean with a microfiber cloth.

Dampen cloth lightly with water.

Do not soak the roofliner.

Safety belts

WARNING

Chemical cleansers can destroy the safety belt webbing. Missing protective effect of the safety belts. There is a risk of injuries or danger to life. Use only a mild soapy solution for cleaning the safety belts.

Dirty belt straps impede the reeling action and thus have a negative impact on safety.

Use only a mild soapy solution, with the safety belts clipped into their buckles.

Safety belts should only be allowed to retract if they are dry.

Carpets and floor mats

WARNING

Objects in the driver's floor area can limit the pedal distance or block a depressed pedal. There is a risk of an accident. Stow objects in the vehicle such that they are secured and cannot enter into the driver's floor area. Use floor mats that are suitable for the vehicle and can be safely attached to the floor. Do not use loose floor mats and do not layer several floor mats. Make sure that there is sufficient clearance for the pedals. Ensure that the floor mats are securely fastened again after they were removed, for instance for cleaning.

Floor mats can be removed from the car's interior for cleaning.

If the floor carpets are very dirty, clean with a microfiber cloth and water or an upholstery cleaner. To prevent matting of the carpet, rub back and forth in the direction of travel only.

Sensor/camera lenses

To clean sensors and camera lenses, use a cloth moistened with a small amount of glass detergent.

Displays/screens

NOTE

Chemical cleansers, moisture or fluids of any kind can damage the surface of displays and screens. There is a risk of damage to property. Clean with a clean, antistatic microfiber cloth.

NOTE

The surface of displays can be damaged with improper cleaning. There is a risk of damage to property. Avoid pressure that is too high and do not use any scratching materials.

Clean with a clean, antistatic microfiber cloth.

Long idle times and long-term vehicle storage

Concept

For idle phases that last several weeks, park the vehicle with a fully charged battery if possible.

Do not park the vehicle for longer than 14 days if the electric range is less than 6 mls, approx. 10 km.

With storage times of up to three months, if possible plug the vehicle into a compatible power source or park it in a nearly fully charged state.

General information

Your dealer's service center or another qualified service center or repair shop can advise you on what to consider when storing the vehicle for longer than three months.

Follow the instructions for discharging the high-voltage battery, refer to page [199](#).

Safety information

NOTICE

The high-voltage battery can be damaged by excessive discharge. There is a risk of damage to property. Before storing the vehicle for an extended period, ensure that the high-voltage battery is fully charged. During the idle period, connect the vehicle to a charging station at a compatible charging location. If necessary, the high-voltage battery will be charged automatically. Make sure that the charging process takes place. Regularly check the charge state.

Do not allow the vehicle to sit idle for longer than four weeks with a charge state below approx. 80 %.



Technical data

Vehicle features and options

This chapter describes all standard, country-specific and optional features offered with the series. It also describes features that are not necessarily

available in your vehicle, e. g., due to the selected options or country versions. This also applies to safety-related functions and systems. When using these functions and systems, the applicable laws and regulations must be observed.

General information

The technical data and specifications in this Owner's Manual are used as guidance values. The vehicle-specific data can deviate from this, for instance due to the selected special equipment, country version or country-specific meas-

urement method. Detailed values can be found in the approval documents, on labels on the vehicle or can be obtained from a dealer's service center or another qualified service center or repair shop.

Dimensions

The dimensions can vary depending on the model version, equipment or country-specific measurement method.

The specified heights do not take into account attached parts, for instance a roof antenna, roof

racks or spoiler. The heights can deviate, for instance due to the selected special equipment, tires, load and chassis version.

BMW i3

Width with mirrors	Inches/mm	80.3/2,039
Width without mirrors	Inches/mm	69.9/1,775
Height	Inches/mm	62.9/1,598
Length	Inches/mm	158.3/4,020
Wheelbase	Inches/mm	101.2/2,570
Smallest turning radius diam.	ft/m	32.4/9.9

BMW i3s

Width with mirrors	Inches/mm	80.3/2,039
Width without mirrors	Inches/mm	70.5/1,791

BMW i3s

Height	Inches/mm	62.6/1,590
Length	Inches/mm	158.1/4,016
Wheelbase	Inches/mm	101.2/2,570
Smallest turning radius diam.	ft/m	33.9/10.3

Weights

BMW i3 (94 Ah)

Approved gross vehicle weight	lbs/kg	3,858/1,750
Load	lbs/kg	838/380
Approved front axle load	lbs/kg	1,759/798
Approved rear axle load	lbs/kg	2,205/1,000

BMW i3s (94 Ah)

Approved gross vehicle weight	lbs/kg	3,858/1,750
Load	lbs/kg	816/370
Approved front axle load	lbs/kg	1,759/798
Approved rear axle load	lbs/kg	2,205/1,000

BMW i3 (94 Ah with Range Extender)

Approved gross vehicle weight	lbs/kg	3,951/1,792
Load	lbs/kg	666/302
Approved front axle load	lbs/kg	1,775/805
Approved rear axle load	lbs/kg	2,271/1,030

BMW i3s (94 Ah with Range Extender)

Approved gross vehicle weight	lbs/kg	3,951/1,792
Load	lbs/kg	650/295

BMW i3s (94 Ah with Range Extender)

Approved front axle load	lbs/kg	1,775/805
Approved rear axle load	lbs/kg	2,271/1,030

Capacities

	US gal/liters	Notes
Fuel tank, approx.	2.2/8.7	With optional Range Extender Fuel quality, refer to page 224 .

Appendix

Any updates to the Owner's Manual of the vehicle are listed here.

Everything from A to Z

Index

A

ABS, Antilock Brake System [149](#)
 ACC, Active Cruise Control with Stop & Go function [153](#)
 Accelerator pedal positions [105](#)
 Accessories and parts [10](#)
 Acoustic pedestrian protection [106](#)
 AC quick charging cable, see Level 2 charging cable [212](#)
 Activated-charcoal filter [178](#)
 Active Cruise Control with Stop & Go function ACC [153](#)
 Adaptive brake lights, see Brake force display [147](#)
 Adjustments, steering wheel [95](#)
 Advance climate control, see Stationary climate control [178](#)
 After washing vehicle [259](#)
 Airbags [133](#)
 Airbags, indicator and warning light [134](#)
 Air circulation, see Recirculated-air mode [173](#), [177](#)
 Air conditioner [172](#)
 Air conditioning [173](#), [176](#)
 Air, dehumidifying, see Air conditioning [173](#), [176](#)
 Air distribution, manual [174](#), [177](#)
 Air flow, air conditioner [173](#)
 Air flow, automatic climate control [177](#)
 Air pressure, tires [226](#)
 Air vents, see Ventilation [178](#)
 Alarm system [82](#)
 Alarm, unintentional [84](#)
 All-season tires, see Winter tires [231](#)
 Ambient light [132](#)
 Antifreeze, washer fluid [112](#)
 Antilock Brake System, ABS [149](#)
 Anti-slip control, see DSC [149](#)
 Anti-theft protection, lug bolts [238](#)

App, BMW i Driver's Guide [60](#)
 Approach control warning with City light braking function [142](#)
 Approved axle load [267](#)
 Apps, see Owner's Handbook for Navigation, Entertainment, Communication [8](#)
 Artificial engine noise [106](#)
 Ashtray [185](#)
 Assistance when driving off [151](#)
 AUTO intensity [177](#)
 Automatic climate control [175](#)
 Automatic cornering adjustment [94](#)
 Automatic cruise control with Stop & Go function [153](#)
 Automatic Curb Monitor [94](#)
 Automatic deactivation, front-seat passenger airbags [135](#)
 Automatic deactivation of the high-voltage system [66](#)
 Automatic headlight control [130](#)
 Automatic locking [82](#)
 Automatic recirculated-air control [177](#)
 Automatic unlocking [82](#)
 Automatic vehicle wash [258](#)
 AUTO program, automatic climate control [176](#)
 AUTO program, intensity [177](#)
 Auto washing [258](#)
 Average fuel consumption [126](#)
 Average speed [126](#)
 Axle loads, weights [267](#)

B

Back doors [75](#)
 Backrest, seats [88](#)
 Band-aids, see First-aid kit [254](#)
 Battery, 12 volt [252](#)
 Battery replacement, vehicle battery [252](#)
 Battery replacement, vehicle remote control [72](#)
 Battery state indicator [116](#)

- Battery, vehicle [252](#)
 - Being towed, see [Towing 255](#)
 - Belts, safety belts [90](#)
 - Bluetooth connection [53](#)
 - Blu-ray, see [Owner's Handbook for Navigation, Entertainment, Communication 8](#)
 - BMW 360° ELECTRIC Portal, see [Intelligent charging 218](#)
 - BMW Assist, see [Owner's Manual for Navigation, Entertainment and Communication 8](#)
 - BMW eDRIVE [63](#)
 - BMW Homepage [8](#)
 - BMW i Driver's Guide app [60](#)
 - BMW Internet page [8](#)
 - BMW maintenance system [249](#)
 - Body work, see [Working on the vehicle 66](#)
 - Brake assistant [149](#)
 - Brake discs, break-in [198](#)
 - Brake force display [147](#)
 - Brake lights, brake force display [147](#)
 - Brake pads, break-in [198](#)
 - Braking, information [200](#)
 - Breakdown assistance [254](#)
 - Break-in [198](#)
 - Brightness of Control Display [50](#)
 - Bulb replacement [252](#)
 - Bulbs and lights [252](#)
 - Button, RES [156](#)
 - Button, Start/Stop [100](#)
 - Bypassing, see [Jump-starting 255](#)
- C**
- Calendar, see [Owner's Handbook for Navigation, Entertainment, Communication 8](#)
 - California Proposition 65 Warning [11](#)
 - Camera-based assistance systems, see [Intelligent Safety 141](#)
 - Camera-based cruise control [153](#)
 - Camera lenses, care [261](#)
 - Camera, rearview camera [165](#)
 - Care, displays [261](#)
 - Care, vehicle [259](#)
 - Care, washing the vehicle [258](#)
 - Cargo [202](#)
 - Cargo area [187](#)
 - Cargo area, enlarging [188](#)
 - Cargo area, loading [203](#)
 - Cargo area, storage compartments [194](#)
 - Cargo cover [187](#)
 - Cargo position, rear seat backrest [188](#)
 - Cargo, stowing and securing [203](#)
 - Cargo straps [203](#)
 - Carpet, care [261](#)
 - Catalytic converter, see [Hot exhaust gas system 199](#)
 - CBS Condition Based Service [249](#)
 - Center armrest [192](#)
 - Center console [36](#)
 - Central Information Display (CID), see [Control Display 38](#)
 - Central locking system [75](#)
 - Central screen, see [Control Display 38](#)
 - Changes, technical, see [For Your Own Safety 10](#)
 - Changing wheels [237](#)
 - Changing wheels/tires [231](#)
 - Charge state indicator, high-voltage battery [116](#)
 - Charging battery, see [Vehicle charging 210](#)
 - Charging cable storage [213](#)
 - Charging cable, unlocking manually [214](#)
 - Charging screen [115](#)
 - Charging, see [Charging the vehicle 210](#)
 - Charging, see [Vehicle charging 210](#)
 - Charging socket flap, unlocking manually [214](#)
 - Charging status, see [Display of the charging status 216](#)
 - Charging the vehicle [210](#)
 - Charging the vehicle, see [Vehicle charging 210](#)
 - Chassis number, see [Vehicle identification number 14](#)
 - Check Control [118](#)
 - Check engine oil [244](#)
 - Checking the oil level electronically [245](#)
 - Check oil level [244](#)
 - Children, seating position [96](#)
 - Children, transporting safely [96](#)
 - Child restraint system [96](#)
 - Child restraint system LATCH [98](#)
 - Child restraint systems, mounting [97](#)
 - Child seat, mounting [97](#)
 - Child seats [96](#)

Chrome parts, care [260](#)
 Cigarette lighter [185](#)
 Cleaning, displays [261](#)
 Climate control [172](#), [175](#)
 Clothes hooks [194](#)
 Coasting [105](#)
 Combination switch, see Turn signals [109](#)
 Combination switch, see Wiper system [109](#)
 Comfort Access [76](#)
 COMFORT program, driving dynamics [151](#)
 Compartments in the doors [193](#)
 Compass [183](#)
 Compatible devices, see Suitable devices [52](#)
 Compressor [232](#)
 Computer, see Onboard Computer [126](#)
 Concierge Service, see Owner's Handbook for Navigation, Entertainment, Communication [8](#)
 Condensation on windows [174](#), [178](#)
 Condensation under the vehicle [201](#)
 Condition Based Service CBS [249](#)
 Confirmation signal [82](#)
 ConnectedDrive, see Owner's Manual for Navigation, Entertainment and Communication [8](#)
 Connecting device [52](#)
 Connecting mobile phone [52](#)
 Connecting smartphone [52](#)
 Connecting telephone [52](#)
 Connections [52](#)
 Contacts, see Owner's Handbook for Navigation, Entertainment, Communication [8](#)
 Contact with water, high-voltage system [66](#)
 Container for washer fluid [112](#)
 Control Display [38](#)
 Control Display, settings [48](#)
 Controller [39](#)
 Control systems, driving stability [149](#)
 Convenient closing with the remote control [71](#)
 Convenient opening with the remote control [71](#)
 Coolant [247](#)
 Coolant temperature [121](#)
 Cooling, maximum [176](#)
 Cooling system [247](#)
 Corrosion on brake discs [201](#)
 Cosmetic mirror [185](#)
 Coupling, see Pairing [52](#)
 Courtesy lights during unlocking [71](#)

Courtesy lights with the vehicle locked [72](#)
 Cruise control [159](#)
 Cruise control, active with Stop & Go function [153](#)
 Cruise control with distance control, see Camera-based cruise control ACC [153](#)
 Cruise control without distance control, see Cruise control [159](#)
 Cruising range [122](#)
 Current fuel consumption [126](#)

D

Damage, tires [230](#)
 Data memory [12](#)
 Data protection, settings [51](#)
 Data, technical [266](#)
 Date [48](#)
 Daytime running lights [131](#)
 DCC, see Cruise control [159](#)
 Defrosting, see Windows, defrosting [174](#), [178](#)
 Dehumidifying, air [173](#), [176](#)
 Deleting personal data [51](#)
 Deletion of personal data [51](#)
 Departure times, stationary climate control [179](#)
 Device list [52](#)
 Digital clock [122](#)
 Digital compass [183](#)
 Dimensions [266](#)
 Dimmable exterior mirrors [94](#)
 Dimmable interior mirror [95](#)
 Direction indicator, see Turn signals [109](#)
 Display for performance and energy recovery [116](#)
 Display lighting, see Instrument lighting [131](#)
 Displays [114](#)
 Displays, care [261](#)
 Displays, eDRIVE system [115](#)
 Displays, high-voltage system [115](#)
 Disposal, coolant [248](#)
 Disposal, vehicle battery [253](#)
 Distance control, see PDC [162](#)
 Divided screen view, split screen [42](#)
 Door key, see Remote control [74](#)
 Drive display [116](#)
 Drive-off assistant [151](#)

- Drive-off assistant, see DSC [149](#)
- Driver assistance, see Intelligent Safety [141](#)
- Drive-ready state in detail [101](#)
- Drive-ready state, switching off [104](#)
- Drive-ready state, switching on [101](#)
- Driver profiles [79](#)
- Driver profiles, exporting profiles [81](#)
- Driver profiles, importing profiles [81](#)
- Driver's Guide app, see BMW i Driver's Guide app [60](#)
- Driving Dynamics Control [150](#)
- Driving in detail [104](#)
- Driving instructions, break-in [198](#)
- Driving instructions, eDRIVE drive system [198](#)
- Driving mode [150](#)
- Driving notes, general [199](#)
- Driving on racetracks [201](#)
- Driving, see Drive-ready state in detail [101](#)
- Driving stability control systems [149](#)
- Driving, Start/Stop button [100](#)
- Driving style analysis [207](#)
- Driving tips [199](#)
- DSC Dynamic Stability Control [149](#)
- DTC Dynamic Traction Control [150](#)
- DVD, Video, see Owner's Handbook for Navigation, Entertainment, Communication [8](#)
- Dynamic Stability Control DSC [149](#)
- Dynamic Traction Control DTC [150](#)
- ## E
- ECO PRO [205](#)
- ECO PRO+ [205](#)
- ECO PRO display [205](#)
- ECO PRO driving mode [205](#)
- ECO PRO driving style analysis [207](#)
- ECO PRO mode [205](#)
- ECO PRO Tip - driving instruction [206](#)
- eDRIVE drive system, driving instructions [198](#)
- eDRIVE, electric driving, see BMW eDRIVE [64](#)
- eDrive system, at a glance [63](#)
- eDRIVE system, displays [115](#)
- Efficiency display, ECO PRO [206](#)
- Electric driving [104](#)
- Electric driving, see BMW eDRIVE [64](#)
- Electric range [122](#)
- Electronic oil measurement [245](#)
- Electronic Stability Program ESP, see DSC [149](#)
- E-mail, see Owner's Handbook for Navigation, Entertainment, Communication [8](#)
- Emergency release, fuel filler flap [222](#)
- Emergency Request [254](#)
- Emergency unlocking, charging cable [214](#)
- Emergency unlocking, charging socket flap [214](#)
- Emergency unlocking, transmission lock [104](#)
- Energy Control [126](#)
- Energy recovery, displaying [116](#)
- Energy recovery, driving stability control systems [149](#)
- Engine coolant [247](#)
- Engine noise, artificial [106](#)
- Engine oil [244](#)
- Engine oil, adding [246](#)
- Engine start, jump-starting [255](#)
- Entering a destination, see Owner's Handbook for Navigation, Entertainment, Communication [8](#)
- Entering an address, navigation, see Owner's Manual for Navigation, Entertainment and Communication [8](#)
- Entering a vehicle wash [258](#)
- Equipment, interior [181](#)
- Error displays, see Check Control [118](#)
- ESP Electronic Stability Program, see DSC [149](#)
- Exchanging wheels/tires [231](#)
- Exhaust gas system [199](#)
- Exhaust, see Exhaust gas system [199](#)
- Exiting a vehicle wash [258](#)
- Expanding range with Range Extender [106](#)
- Exterior mirror, automatic dimming feature [94](#)
- Exterior mirrors [93](#)
- Exterior mirrors, malfunction [94](#)
- External start [255](#)
- External temperature display [122](#)
- External temperature warning [122](#)
- Eyes for securing cargo [203](#)
- ## F
- Failure message, see Check Control [118](#)
- False alarm, see Unintentional alarm [84](#)
- Fan, see Air flow [173, 177](#)

Fastening safety belts, see Safety belts [90](#)
 Finding charging stations, see Charging stations
 and points of interest, see Owner's Handbook
 for Navigation, Entertainment, Communica-
 tion [8](#)
 Fine wood, care [261](#)
 First-aid kit [254](#)
 Flat tire, changing wheels [237](#)
 Flat tire message, FTM [140](#)
 Flat tire message, TPM [138](#)
 Flat Tire Monitor FTM [139](#)
 Flat tire, repairing [232](#)
 Flat tire, Tire Pressure Monitor TPM [136](#)
 Flat tire warning light, FTM [140](#)
 Flat tire warning light, TPM [138](#)
 Flooding [200](#)
 Floor carpet, care [261](#)
 Floor mats, care [261](#)
 Fold-away position, wiper [112](#)
 Fold back rear seat backrests [188](#)
 Foot brake [200](#)
 For Your Own Safety [10](#)
 Front airbags [133](#)
 Front armrest [192](#)
 Front beverage holder, front cup holder [192](#)
 Front bottle holder, see Front cup holder [192](#)
 Front can holder, see Front cup holder [192](#)
 Front cup holder [192](#)
 Front holder for beverages [192](#)
 Front-seat passenger airbags, automatic deacti-
 vation [135](#)
 Front-seat passenger airbags, indicator light [136](#)
 Front seats [88](#)
 FTM Flat Tire Monitor [139](#)
 Fuel [224](#)
 Fuel cap [222](#)
 Fuel consumption, see Average fuel consump-
 tion [126](#)
 Fuel filler flap [222](#)
 Fuel gauge, Range Extender [121](#)
 Fuel quality [224](#)
 Fuel recommendation [224](#)
 Fuel, tank capacity [268](#)
 Fuse [253](#)

G

Garage door opener, see Integrated Universal
 Remote Control [181](#)
 Gasoline [224](#)
 General driving notes [199](#)
 General settings [48](#)
 Glare shield [185](#)
 Glass sunroof, electric [85](#)
 Glass sunroof, initialize the system [86](#)
 Glove compartment [191](#)
 GPS geolocation, vehicle position [49](#)
 GPS, navigation, see Owner's Handbook for
 Navigation, Entertainment, Communication [8](#)
 Gross vehicle weight, approved [267](#)

H

Handbrake, see Parking brake [107](#)
 Hand-held transmitter, alternating code [182](#)
 Hands-free kit, see Owner's Handbook for Navi-
 gation, Entertainment, Communication [8](#)
 Hazard warning flashers [254](#)
 Head airbags [133](#)
 Headlight control, automatic [130](#)
 Headlight courtesy delay feature [130](#)
 Headlight flasher [109](#)
 Headlight glass [252](#)
 Headlights, care [259](#)
 Head restraints, front [91](#)
 Head restraints, rear [92](#)
 Heavy cargo, stowing cargo [203](#)
 Height, vehicle [266](#)
 High beams [109](#)
 High-voltage battery, charge state indicator [116](#)
 High-voltage battery, discharge [199](#)
 High-voltage battery, heated [107](#)
 High-voltage battery, heavily discharged [106](#)
 High-voltage system, automatic deactivation [66](#)
 High-voltage system, contact with water [66](#)
 High-voltage system, displays [115](#)
 High-voltage system, safety [66](#)
 Hills [201](#)
 Hill start assistant, see Drive-off assistant [151](#)
 Hold function [108](#)
 Homepage [8](#)

Hood [78](#)
Horn [34](#)
Hot exhaust gas system [199](#)
Hotline, see *Owner's Handbook for Navigation, Entertainment, Communication* [8](#)
Hydroplaning [200](#)

I

Ice warning, see *External temperature warning* [122](#)
Icy roads, see *External temperature warning* [122](#)
Identification marks, tires [228](#)
Identification number, see *Vehicle identification number* [14](#)
iDrive [38](#)
Ignition key, see *Remote control* [74](#)
Illuminant replacement [252](#)
Important under the hood [242](#)
Increasing the range [204](#)
Indicator and warning lights, see *Check Control* [118](#)
Indicator light, see *Check Control* [118](#)
Individual air distribution [174](#), [177](#)
Individual settings, see *Driver profiles* [79](#)
Inductive charging, see *Wireless charging*, see *Owner's Handbook for Navigation, Entertainment, Communication* [8](#)
Inflation pressure, tires [226](#)
Inflation pressure warning FTM, tires [139](#)
Info Display, see *Onboard Computer* [126](#)
Information [8](#)
Initialize, *Tire Pressure Monitor TPM* [137](#)
Initializing, *Flat Tire Monitor FTM* [140](#)
Instrument cluster [114](#)
Instrument lighting [131](#)
Integrated key [74](#)
Integrated *Owner's Manual* in the vehicle [59](#)
Intelligent charging [218](#)
Intelligent emergency call [254](#)
Intelligent Safety [141](#)
Intended use [10](#)
Intensity, *AUTO* program [177](#)
Interior equipment [181](#)
Interior lights [131](#)
Interior lights during unlocking [71](#)

Interior lights with the vehicle locked [72](#)
Interior mirror [93](#)
Interior mirror, automatic dimming feature [95](#)
Interior mirror, compass [183](#)
Interior mirror, manually dimmable [95](#)
Interior motion sensor [83](#)
Internet page [8](#)
Interval display, service requirements [123](#)
Interval mode [110](#)
In the vicinity of the center console [36](#)
In the vicinity of the roofliner [37](#)
In the vicinity of the steering wheel [34](#)

J

Jacking points for the vehicle jack [239](#)
Jam protection system, glass sunroof [86](#)
Jam protection system, windows [85](#)
Jump-starting [255](#)

K

Kenaf, care [261](#)
Key/remote control [74](#)
Keyless Go, see *Comfort Access* [76](#)
Key, see *Remote control* [70](#)
Knee airbag [134](#)

L

Label on recommended tires [231](#)
Language, on the *Control Display* [48](#)
Lashing eyes [203](#)
LATCH child restraint fixing system [98](#)
Leather, care [260](#)
LEDs, light-emitting diodes [252](#)
Length, vehicle [266](#)
Level 1 charging [217](#)
Level 1 charging cable [212](#)
Level 2 charging [217](#)
Level 2 charging cable [212](#)
Light [129](#)
Light-alloy wheels, care [260](#)
Light-emitting diodes, LEDs [252](#)
Lighting [129](#)
Light replacement, see *Bulb replacement* [252](#)

Light switch [129](#)
 List of all messages [50](#)
 Load [203](#)
 Loading [202](#)
 Loading position [188](#)
 Location, vehicle position [49](#)
 Locking, automatic [82](#)
 Locking, settings [82](#)
 Longer idle phases [262](#)
 Long idle times and long-term vehicle storage [262](#)
 Long-term vehicle storage [262](#)
 Low beams [129](#)
 Lug bolt lock [238](#)

M

Maintaining charge state, see Range Extender [106](#)
 Maintenance [249](#)
 Maintenance requirements [249](#)
 Maintenance, service requirements [123](#)
 Maintenance system, BMW [249](#)
 Make-up mirror [185](#)
 Malfunction displays, see Check Control [118](#)
 Manual air distribution [174](#), [177](#)
 Manual air flow [173](#), [177](#)
 Manual operation, fuel filler flap [222](#)
 Manual operation, PDC Park Distance Control [163](#)
 Manual operation, rearview camera [166](#)
 Map update, see Owner's Handbook for Navigation, Entertainment and Communication [8](#)
 Master key, see Remote control [74](#)
 Matte finish [260](#)
 Maximum cooling [176](#)
 Maximum speed, display [124](#)
 Maximum speed, winter tires [232](#)
 Measurement, units of [49](#)
 Medical kit [254](#)
 Menu in instrument cluster [125](#)
 Menus [40](#)
 Menus, operating, iDrive [38](#)
 Messages [50](#)
 Messages, see Check Control [118](#)
 Microfilter [174](#), [178](#)

Minimum tread, tires [230](#)
 Mirror [93](#)
 Mobile communication devices in the vehicle [200](#)
 Mobility System [232](#)
 Modifications, technical, see For Your Own Safety [10](#)
 Moisture in headlight [252](#)
 Monitor, see Control Display [38](#)
 Mounting of child restraint systems [97](#)
 MP3 player, see Audio, see Owner's Handbook for Navigation, Entertainment, Communication [8](#)
 Multifunction steering wheel, buttons [34](#)
 Multimedia, see Owner's Manual for Navigation, Entertainment and Communication [8](#)
 Music hard disk, see Owner's Handbook for Navigation, Entertainment, Communication [8](#)

N

Navigation, see Owner's Manual for Navigation, Entertainment and Communication [8](#)
 Neck restraints, front, see Head restraints [91](#)
 Neck restraints, rear, see Head restraints [92](#)
 Neutral cleaner, see Wheel cleaner [260](#)
 New wheels and tires [231](#)
 Notes, see Owner's Handbook for Navigation, Entertainment, Communication [8](#)

O

OBD Onboard Diagnosis [250](#)
 OBD, see OBD Onboard Diagnosis [250](#)
 Obstacle marking, rearview camera [167](#)
 Octane rating, see Recommended fuel grade [224](#)
 Odometer [122](#)
 Office, see Owner's Manual for Navigation, Entertainment and Communication [8](#)
 Oil [244](#)
 Oil, adding [246](#)
 Oil change interval, service requirements [123](#)
 Old batteries, disposal [253](#)
 Onboard Computer [126](#)
 Onboard literature, printed [59](#)

Online Entertainment, see Owner's Handbook for Navigation, Entertainment, Communication [8](#)
Online Owner's Manual [61](#)
Opening and closing [70](#)
Operating concept, iDrive [38](#)
Operating via iDrive [40](#)
Operating with the Controller [40](#)
Optional equipment [9](#)
Outside air, see Automatic recirculated-air control [177](#)
Overheating of engine, see Coolant temperature [121](#)
Owner's Manual media [59](#)
Owner's Manual, printed [59](#)

P

Paint, vehicle [259](#)
Panic alarm, see Panic mode [83](#)
Panic mode [83](#)
Parallel parking assistant [168](#)
Park Distance Control PDC [162](#)
Parked vehicle, condensation [201](#)
Parked vehicle ventilation, see Stationary climate control [178](#)
Parking aid, see PDC [162](#)
Parking assistant [168](#)
Parking brake [107](#)
Parking lights [129](#)
Parts and accessories [10](#)
Passenger's side mirror, tilting downward [94](#)
Pathway lines, rearview camera [166](#)
PDC Park Distance Control [162](#)
Pedestrian protection [106](#)
Performance display [116](#)
Personal profile, see Driver profiles [79](#)
Person warning with City light braking function [145](#)
Plastic, care [261](#)
PostCrash [147](#)
Power failure [253](#)
Power sunroof, glass [85](#)
Power windows [84](#)
Pressure, tires [226](#)
Pressure warning FTM, tires [139](#)
Printed onboard literature [59](#)
Profiles, see Driver profiles [79](#)
Programmable memory buttons, iDrive [43](#)
Protective function, glass sunroof [86](#)
Protective function, windows [85](#)
Push-and-turn reel, see Controller [39](#)

Q

Quick charging cable, see Level 2 charging cable [212](#)
Quick charging, see Level 2 charging [217](#)

R

Racetrack operation [201](#)
Radiator fluid [247](#)
Radio-operated key, see Remote control [74](#)
Radio-operated remote control, opening/closing [70](#)
Radio, see Owner's Manual for Navigation, Entertainment and Communication [8](#)
Rain sensor [110](#)
Range Extender, expanding range [106](#)
Range Extender, Fuel gauge [121](#)
Range Extender, maintenance run [106](#)
Range Extender, use [106](#)
Ratchet straps [203](#)
Rear beverage holder, rear cup holder [193](#)
Rear bottle holder, see Rear cup holder [193](#)
Rear can holder, see Rear Cup holder [193](#)
Rear cup holder [193](#)
Rear doors [75](#)
Rear holder for beverages [193](#)
Rearview camera [165](#)
Rear window defroster [174](#), [178](#)
Recirculated-air filter [178](#)
Recirculated-air mode [173](#), [177](#)
Recommended fuel grade [224](#)
Recommended tire brands [231](#)
Refueling [221](#)
Remaining range [122](#)
Remote control/key [74](#)
Remote control, additional [73](#)

Remote control for audio, see Owner's Handbook for Navigation, Entertainment, Communication [8](#)

Remote control, loss [73](#)

Remote control, malfunction [73](#)

Remote control, opening/closing [70](#)

Remote control, universal [181](#)

Remote services, app, see Owner's Handbook for Navigation, Entertainment, Communication [8](#)

Replacing wheels/tires [231](#)

Reporting safety malfunctions [15](#)

RES button [156](#)

RES button, see Camera-based cruise control ACC [153](#)

RES button, see Cruise control [159](#)

Reserve warning, see Range [122](#)

Reset, Tire Pressure Monitor TPM [137](#)

Retreaded tires [231](#)

Roadside parking lights [129](#)

Rolling code hand-held transmitter [182](#)

RON recommended fuel grade [224](#)

Roofliner [37](#)

Route, navigation, see Owner's Handbook for Navigation, Entertainment, Communication [8](#)

RTTI, see Owner's Handbook for Navigation, Entertainment, Communication [8](#)

Rubber components, care [260](#)

S

Safe braking [200](#)

Safety belt reminder for driver's seat and front passenger seat [91](#)

Safety belts [90](#)

Safety belts, care [261](#)

Safety of the high-voltage system [66](#)

Safety systems, airbags [133](#)

Screen, see Control Display [38](#)

Sealant [232](#)

Seat heating, front [90](#)

Seating position for children [96](#)

Seats, front [88](#)

Securing cargo [203](#)

Selection list in instrument cluster [125](#)

Sensors, care [261](#)

Service and warranty [11](#)

Service requirements, Condition Based Service CBS [249](#)

Service requirements, display [123](#)

Services, ConnectedDrive, see Owner's Manual for Navigation, Entertainment and Communication [8](#)

SET button, see Camera-based cruise control ACC [153](#)

SET button, see Cruise control [159](#)

Settings, locking/unlocking [82](#)

Settings on the Control Display [48](#)

Side airbags [133](#)

Signaling, horn [34](#)

Signals when unlocking [82](#)

Sitting safely [88](#)

Size [266](#)

Slide/tilt glass roof [85](#)

Smallest turning radius [266](#)

SMS, see Short messages, see Owner's Handbook for Navigation, Entertainment, Communication [8](#)

SMS text message, supplementary [121](#)

Snow chains [236](#)

Socket [186](#)

Socket, OBD Onboard Diagnosis [250](#)

Software update [57](#)

SOS button [254](#)

Sound output, see Owner's Handbook for Navigation, Entertainment, Communication [8](#)

Speed, average [126](#)

Speed Limit Info [124](#)

Speed Limit Info, Onboard Computer [127](#)

Speed limits, display [124](#)

Speed warning [127](#)

Split screen [42](#)

SPORT program, driving dynamics [151](#)

Stability control systems [149](#)

Standard charging cable, see Level 1 charging cable [212](#)

Standard charging, see Level 1 charging [217](#)

Standard equipment [9](#)

Standby state [101](#)

Start/Stop button [100](#)

Stationary climate control [178](#)

Stations, AM/FM, see Owner's Handbook for Navigation, Entertainment, Communication **8**

Status control display, tires **137**

Status information, iDrive **42**

Status of Owner's Manual **9**

Status, vehicle **128**

Steering wheel, adjusting **95**

Storage compartments **191**

Storage compartments, locations **191**

Storage, tires **232**

Storing the charging cable, see Storage **213**

Storing the vehicle **262**

Stowing and securing cargo **203**

Suitable devices **52**

Suitable mobile phones **52**

Summer tires, tread **230**

Sun visor **185**

Supplementary SMS text message **121**

Switch for driving dynamics **150**

Switching off, drive-ready state **104**

Switching on, drive-ready state **101**

Switch, see Cockpit **34**

Symbols **9**

Symbols in the status field **43**

T

Tailgate opening **79**

Tailgate via remote control **72**

Tank unlocking, see Tank vent **221**

Tank vent **221**

Technical changes, see For Your Own Safety **10**

Technical data **266**

Telephone, see Owner's Manual for Navigation, Entertainment and Communication **8**

Teleservices, see Owner's Handbook for Navigation, Entertainment, Communication **8**

Television, TV, see Owner's Handbook for Navigation, Entertainment, Communication **8**

Temperature, air conditioner **173**

Temperature, automatic climate control **175**

Temperature display for external temperature **122**

Theft alarm system, see Alarm system **82**

Tilt alarm sensor **83**

Time **48**

Tire damage **230**

Tire identification marks **228**

Tire inflation pressure **226**

Tire inflation pressure monitor, see FTM **139**

Tire pressure **226**

Tire Pressure Monitor TPM **136**

Tire repair kit, see Mobility System **232**

Tires, changing **231**

Tire sealant, see Mobility System **232**

Tires, everything on wheels and tires **226**

Tire tread **230**

Tone, see Owner's Manual for Navigation, Entertainment and Communication **8**

Total vehicle weight **267**

Touchpad **41**

Towing **255**

TPM Tire Pressure Monitor **136**

Traction control **150**

TRACTION, driving dynamics **150**

Traffic bulletins, see Owner's Handbook for Navigation, Entertainment, Communication **8**

Transmission lock, electronic unlocking **104**

Transporting children safely **96**

Tread, tires **230**

Trip computer **127**

Triple turn signal activation **109**

Trip odometer **122**

Trip recorder, see Trip odometer **122**

Turning radius **266**

Turning radius lines, rearview camera **166**

Turn signals, operation **109**

TV, see Owner's Handbook for Navigation, Entertainment, Communication **8**

U

Unintentional alarm **84**

Units of measurement **49**

Universal remote control **181**

Unlocking, automatic **82**

Unlocking, settings **82**

Updates made after the editorial deadline **9**

Upholstery care **260**

USB connection **54**

USB interface, general information **187**

USB port, see USB interface **187**

Use, intended [10](#)
 Using a smartphone via voice activation [45](#)
 Using Range Extender [106](#)

V

Vanity mirror [185](#)
 Vehicle battery [252](#)
 Vehicle battery, replacing [252](#)
 Vehicle, break-in [198](#)
 Vehicle care [259](#)
 Vehicle care products [259](#)
 Vehicle features and options [9](#)
 Vehicle identification number [14](#)
 Vehicle jack [239](#)
 Vehicle key, see Remote control [74](#)
 Vehicle paint [259](#)
 Vehicle position, vehicle location [49](#)
 Vehicle status [128](#)
 Vehicle wash [258](#)
 Vehicle, washing [258](#)
 Ventilation [178](#)
 Venting, see Stationary climate control [178](#)
 VIN, see Vehicle identification number [14](#)
 Voice activation system [45](#)
 Voice command response, see Owner's Handbook for Navigation, Entertainment, Communication [8](#)

W

Warning and indicator lights, see Check Control [118](#)
 Warning displays, see Check Control [118](#)
 Warning messages, see Check Control [118](#)
 Warning triangle [254](#)
 Warranty [10](#)
 Washer fluid [112](#)
 Washer nozzles, windshield [111](#)
 Washer system [109](#)
 Washing the vehicle [258](#)
 Water, high-voltage system [66](#)
 Water on roads [200](#)
 Weights [267](#)
 Welcome lights [130](#)
 Welcome lights during unlocking [71](#)

What to do after an accident [257](#)
 Wheelbase, vehicle [266](#)
 Wheel cleaner [260](#)
 Wheels, changing [231](#)
 Wheels, everything on wheels and tires [226](#)
 Wheels, Flat Tire Monitor FTM [139](#)
 Wheels, Tire Pressure Monitor TPM [136](#)
 Width, vehicle [266](#)
 Window defroster, rear [174](#)
 Windows, powered [84](#)
 Windshield washer fluid [112](#)
 Windshield washer nozzles [111](#)
 Windshield washer system [109](#)
 Windshield wiper, see Wiper system [109](#)
 Winter storage, care [262](#)
 Winter tires, suitable tires [231](#)
 Winter tires, tread [230](#)
 Wiper [109](#)
 Wiper blades, replacing [251](#)
 Wiper fluid [112](#)
 Wiper, fold-away position [112](#)
 Wiper system [109](#)
 Wireless charging dock, see Owner's Handbook for Navigation, Entertainment, Communication [8](#)
 Wireless charging, see Wireless charging, see Owner's Handbook for Navigation, Entertainment, Communication [8](#)
 Wood, care [261](#)
 Word match concept, navigation [41](#)
 Working on the body, see Working on the vehicle [66](#)
 Working on the high-voltage system, see Working on the vehicle [66](#)
 Working under the hood [243](#)



01402989267 ue



The Ultimate
Driving Machine®



BMW i DRIVER'S GUIDE APP.

Your customized Owner's Manual as an app.
Optimized for smartphones & tablets. Can be used offline.



01402989267 ue

Online Edition for Part no. 01402989267 - II/18