



## Owner's Manual

2013 Audi TT | TTS | TT RS Coupe

Audi  
Vorsprung durch Technik





Audi TT Coupe

Audi TTS Coupe

Audi TT RS Coupe

## **Foreword**

Thank you for choosing an Audi - we value your trust in us.

Your new Audi will allow you to experience the best in groundbreaking technology and premium quality equipment a vehicle has to offer. We recommend that you read your Owner's Manual thoroughly so that you quickly become acquainted with your Audi and make use of all of its features.

In addition to explaining how the different features work, we provide many useful tips and information concerning your safety, how to care for your vehicle and how to maintain your vehicle's value. We also give you useful tips and information on how to drive your vehicle more efficiently and in an environmentally friendly manner.

In the Owner's Manual packet, you will also find a quick reference guide, an Owner's Manual for your Infotainment system and the vehicle maintenance schedule.

We hope you enjoy driving your Audi and we wish you safe and pleasant motoring.

**AUDI AG**



1325618J321

<b>Vehicle literature</b> .....	5	Cup holder .....	62
<b>About this Owner's Manual</b> ...	6	Ashtray .....	62
<b>Controls and equipment</b> .....	8	Cigarette lighter/socket .....	63
<b>Cockpit</b> .....	8	Storage .....	64
General illustration .....	8	<b>Warm and cold</b> .....	66
<b>Instruments and warning/ indicator lights</b> .....	10	Climate controls .....	66
Instruments .....	10	Rear window defogger .....	70
Warning/indicator lights .....	12	Heated seats .....	70
<b>Driver information system</b> ...	22	<b>On the road</b> .....	71
Introduction .....	22	Steering .....	71
Trip computer .....	23	Ignition lock and ignition switch .....	71
Menu display .....	24	Starting and stopping the engine .....	72
Engine oil temperature display .....	26	Parking brake .....	73
Efficiency program .....	26	Starting on hills .....	74
Service interval display .....	28	Speed warning system .....	74
Boost and engine oil temperature indicator .....	28	Cruise control .....	76
Lap timer .....	29	Audi magnetic ride .....	78
On-Board Diagnostic system (OBD) ...	30	Sport mode .....	78
<b>Opening and closing</b> .....	32	Acoustic parking system .....	78
Keys .....	32	<b>Transmission</b> .....	80
Power locking system .....	34	Manual transmission .....	80
Rear lid/trunk lid .....	37	S tronic transmission .....	80
Anti-theft alarm system .....	38	<b>HomeLink®</b> .....	87
Power windows .....	39	Universal remote control .....	87
<b>Clear vision</b> .....	42	<b>Safety first</b> .....	90
Lights .....	42	<b>Driving Safely</b> .....	90
Interior lights .....	45	General notes .....	90
Vision .....	46	Proper occupant seating positions ...	91
Mirrors .....	47	Driver and passenger side footwell ...	95
Wiper and washer system .....	48	Pedal area .....	95
Digital compass .....	52	Stowing luggage .....	96
<b>Seats and storage</b> .....	54	Reporting Safety Defects .....	98
General recommendations .....	54	<b>Safety belts</b> .....	100
Adjusting front seats manually .....	55	General notes .....	100
Power seats .....	56	Why safety belts? .....	101
Head restraints .....	57	Safety belts .....	104
Rear seats .....	58	Safety belt pretensioners .....	106
Luggage compartment .....	59	<b>Airbag system</b> .....	108
Roof rack .....	60	Important things to know .....	108
		Front airbags .....	112

Monitoring the Advanced Airbag System . . . . .	119	Engine cooling system . . . . .	187
Knee airbags . . . . .	123	Brake fluid . . . . .	189
Side airbags . . . . .	126	Battery . . . . .	190
<b>Child Safety</b> . . . . .	<b>130</b>	Windshield/headlight washer container . . . . .	194
Important things to know . . . . .	130	<b>Tires and wheels</b> . . . . .	<b>196</b>
Child safety seats . . . . .	135	Tires . . . . .	196
Installing a child safety seat . . . . .	140	Tire pressure monitoring system . . . . .	214
LATCH Lower anchorages and tethers for children . . . . .	143	Run-flat tires . . . . .	217
Additional Information . . . . .	149	<b>Do-it-yourself service</b> . . . . .	<b>220</b>
<b>Vehicle operation</b> . . . . .	<b>150</b>	<b>What do I do now?</b> . . . . .	<b>220</b>
<b>Intelligent technology</b> . . . . .	<b>150</b>	Vehicle tool kit . . . . .	220
Notice about data recorded by vehicle control modules . . . . .	150	Tire repair . . . . .	220
Electronic Stabilization Control (ESC) . . . . .	150	What should I be aware of when changing a tire? . . . . .	224
Rear spoiler . . . . .	153	<b>Fuses and bulbs</b> . . . . .	<b>228</b>
Braking . . . . .	153	Electrical fuses . . . . .	228
Electro-mechanical power assist . . . . .	155	Bulbs . . . . .	231
Driving with your quattro® . . . . .	155	<b>Emergency situations</b> . . . . .	<b>232</b>
Energy management . . . . .	156	General . . . . .	232
<b>Driving and environment</b> . . . . .	<b>159</b>	Starting by pushing or towing . . . . .	232
The first 1,000 miles (1,500 km) and afterwards . . . . .	159	Starting with jumper cables . . . . .	232
Avoid damaging the vehicle . . . . .	160	Use of jumper cables . . . . .	233
Driving through water on roads . . . . .	160	Emergency towing with commercial tow truck . . . . .	234
Catalytic converter . . . . .	160	Lifting vehicle . . . . .	237
Operate your vehicle economically and minimize pollution . . . . .	161	<b>Technical data</b> . . . . .	<b>238</b>
Trailer towing . . . . .	163	<b>General information</b> . . . . .	<b>238</b>
<b>Vehicle care</b> . . . . .	<b>164</b>	Explanation of technical data . . . . .	238
<b>Cleaning and protection</b> . . . . .	<b>164</b>	Vehicle identification . . . . .	238
General information . . . . .	164	Weights . . . . .	238
Care of exterior . . . . .	164	Dimensions . . . . .	239
Care of interior . . . . .	170		
<b>Fuel supply and filling your fuel tank</b> . . . . .	<b>176</b>		
Gasoline . . . . .	176		
Fuel tank . . . . .	177		
<b>Checking and filling</b> . . . . .	<b>180</b>		
Engine hood . . . . .	180		
Engine oil . . . . .	182		

<b>Data</b> .....	240
211 hp, 2.0 liter 4-cyl. turbo engine (TT Coupe) .....	240
265 hp, 2.0 liter 4-cyl. turbo engine (TTS Coupe) .....	241
360 hp, 2.5 liter 5-cyl. turbo engine (TT RS Coupe) .....	242
<b>Consumer Information</b> .....	243
Warranty coverages .....	243
Operating your vehicle outside the U.S.A. or Canada .....	243
Audi Service Repair Manuals and Literature .....	243
Maintenance .....	243
Additional accessories, modifications and parts replacement .....	245
<b>Index</b> .....	247

In addition to this Owner's Manual, your Audi comes with a Warranty & Maintenance booklet.

Moreover, depending on the model and the equipment, there may be additional instruction booklets delivered with your vehicle (for example, Operating Instructions for your Sound System, Navigation System, etc.).

If you are missing one of these publications, or if you believe that the information is not complete, contact your authorized Audi dealer for assistance.

### **The Warranty & Maintenance booklet**

explains how you can keep your Audi in top driving condition by having it serviced regularly and contains detailed information about the warranties covering your Audi. Always have the booklet with you when you take your vehicle to an authorized Audi dealer for service. Your Audi Service Advisor will record each scheduled service and can answer any questions you may have regarding how to maintain your vehicle.

### **In Canada,**

the vehicle literature is also available in French. To obtain a copy, contact your dealer or write to:

Au Canada, on peut se procurer un exemplaire en français de ce document auprès du concessionnaire ou de:

Volkswagen Canada, Inc.  
Client Assistance  
Assistance a la Clientele  
777 Bayly Street, West,  
Ajax, Ontario L1S 7G7

### **If you sell your Audi**

all literature should be left in the vehicle to make the Warranty terms as well as all operating, safety and maintenance information available to the next owner.

### **If you change your address or if you bought this Audi used**

be sure to send in a "Notice of Address Change" / "Notice of Used Car Purchase" post card. This card can be found in the Warranty & Maintenance booklet or obtained from your authorized Audi dealer.

**It is in your own interest that we are able to contact you should the need arise.**

This owner's manual contains important information, tips, suggestions, and warnings for the use of your vehicle.

Make sure that this owner's manual is always located in the vehicle. This is especially important if you allow other people to drive the vehicle, or if you sell it.

This owner's manual describes the **equipment range** specified for this model at the editorial deadline date. Some of the equipment described here will only be available at a later date, or only in specific markets.

Some sections in this owner's manual do not apply to all vehicles. In that case, the **range of applicability** is given at the beginning of the section, e. g. "Applies to vehicles: with Audi Parking System". In addition, optional or vehicle-specific equipment is indicated by an asterisk "\*".

The details in the **illustrations** may be different from those in your vehicle, and are intended to be viewed as a basic guide.

You will find a **table of contents** at the beginning of this book, which displays all topics described in this manual in order of appearance. You will find an alphabetical **index** at the end of this book.

All **directions**, such as "left", "right", "front", "back", are relative to the direction of travel.

- \* Optional or vehicle-specific equipment
- This section continues on the next page.
- ® Registered trademarks are identified with a ®. If this symbol is missing, it is no guarantee that the terms can be used freely.

⇒ ⚠ Cross-reference to a "WARNING!" within a section. For indication with a page number, the corresponding "WARNING!" can be found outside of the section.

### **WARNING**

Text with this symbol contains important information on safety and how to reduce the risk of personal injury or death.

### **Note**

Text with this symbol draws your attention to potential sources of damage to your vehicle.

### **For the sake of the environment**

Text with this symbol contains information about the environment and how you can help protect it.

### **Tips**

Text with this symbol contains special tips and other information about getting the most out of your vehicle and its features.



## Cockpit

### General illustration

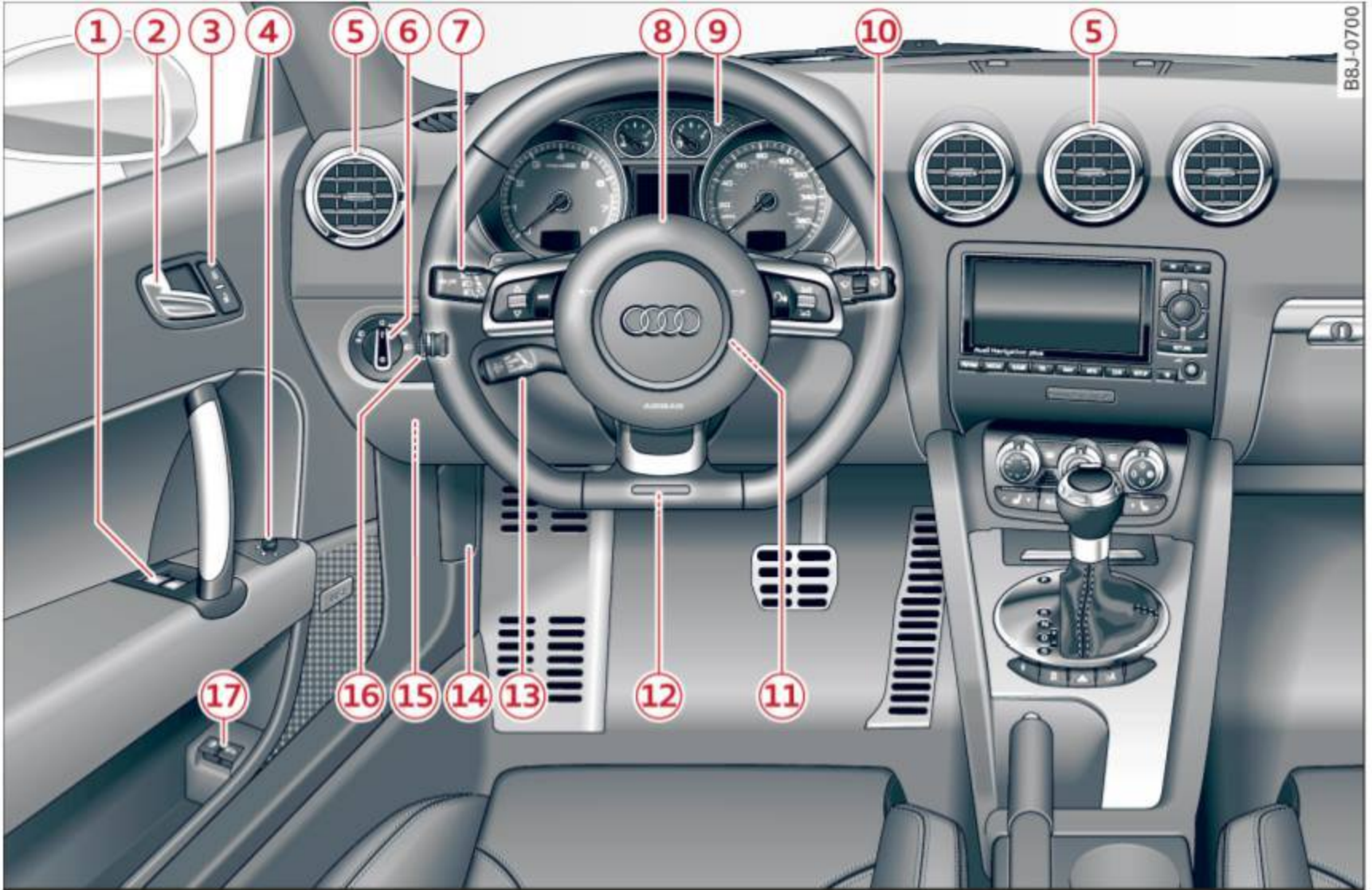

Fig. 1 Cockpit: left section

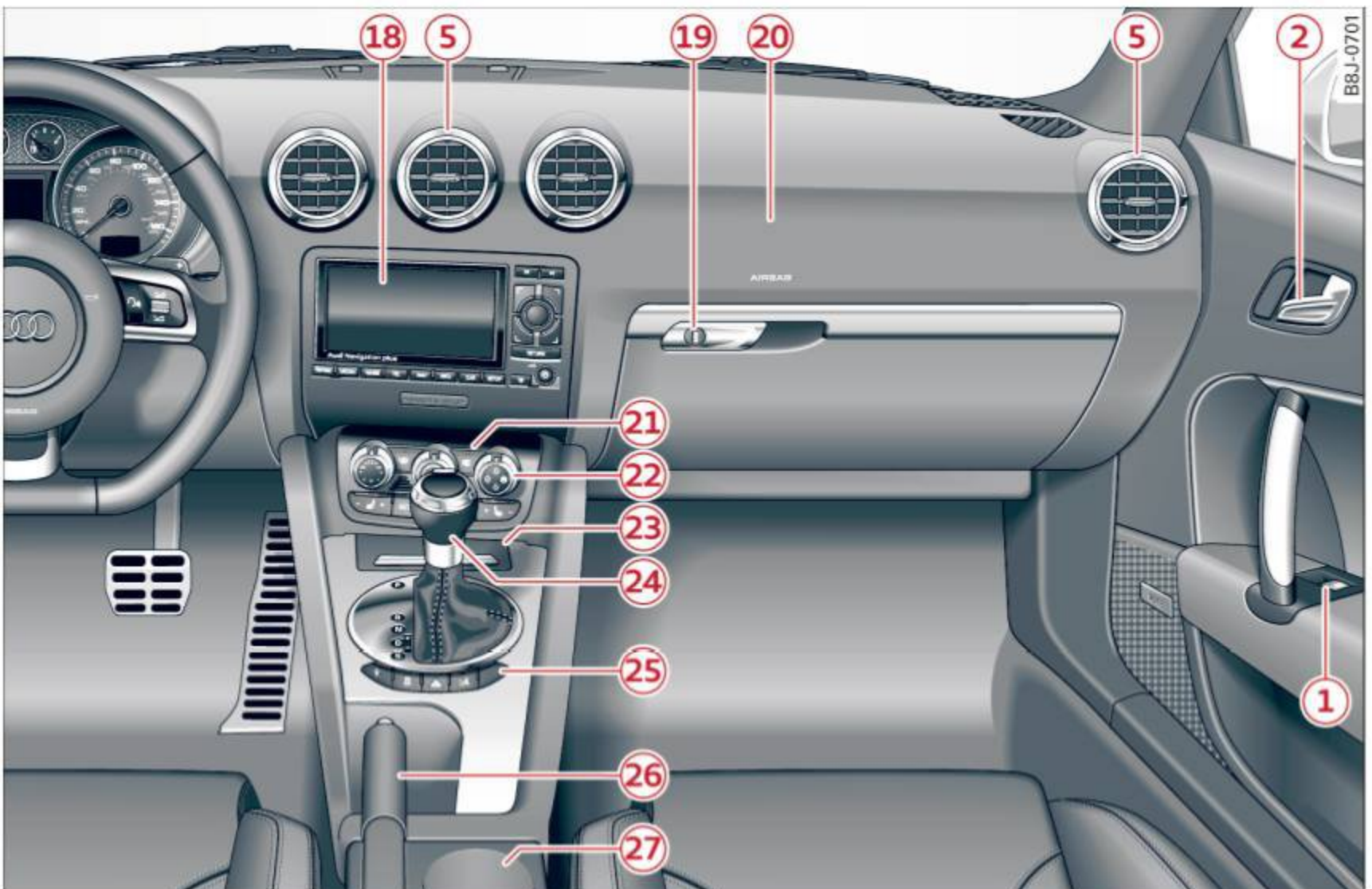

Fig. 2 Cockpit: right section

① Power window switches . . . . .	39	
② Door handle		
③ Power locking switch . . . . .	36	
④ Adjuster control for outside mirrors . . . . .	47	
⑤ Air outlets . . . . .	68	
⑥ Light switch . . . . .	42	
⑦ Turn signal and high beam . . . . .	44	
⑧ Multifunction steering wheel with:		
– Horn		
– Driver's airbag . . . . .	112	
– Shift buttons . . . . .	84	
⑨ Instrument cluster . . . . .	10	
⑩ Switches for		
– Windshield wiper/washer . . . . .	48	
– Menu display . . . . .	24	
– Trip computer . . . . .	23	
⑪ Steering lock/ignition/starter switch (in the steering wheel column) . . . . .	71	
⑫ Adjustable steering column . . . . .	71	
⑬ Cruise control . . . . .	76	
⑭ Hood release . . . . .	180	
⑮ Data Link Connector (DLC) for On Board Diagnostics (OBD II) . . . . .	30	
⑯ Instrument lighting . . . . .	46	
⑰ Switches for		
– Fuel filler flap release . . . . .	178	
– Rear lid release . . . . .	37	
⑱ Depending on options: Radio or navigation system		
⑲ Glove compartment (lockable) . . . . .	64	
⑳ Front passenger's airbag . . . . .	112	
㉑ Rear window defogger switch . . . . .	70	
㉒ Climate controls . . . . .	66	
㉓ Ashtray with cigarette lighter . . . . .	62	
㉔ Selector lever or gearshift lever		
– Selector lever (S tronic) . . . . .	80	
– Gearshift lever . . . . .	80	
㉕ Switches for		
– Audi magnetic ride or Sport mode . . . . .	78, 78	
		– Electronic Stabilization Control . . . . .
		– Emergency flasher . . . . .
		– Retractable rear spoiler . . . . .
		㉖ Parking brake lever . . . . .
		㉗ Cup holder . . . . .
		150
		45
		153
		73
		62

### **i** Tips

- Some of the equipment or features shown in the general illustration may be standard equipment on your vehicle or may be optional equipment depending on your model. Always ask your authorized Audi dealer if you have a question about your vehicle.
- A separate brochure is provided for your factory-installed audio system and/or the Audi Navigation System.

# Instruments and warning/indicator lights

## Instruments

### Instrument cluster and controls

The instrument cluster is your central source of information.

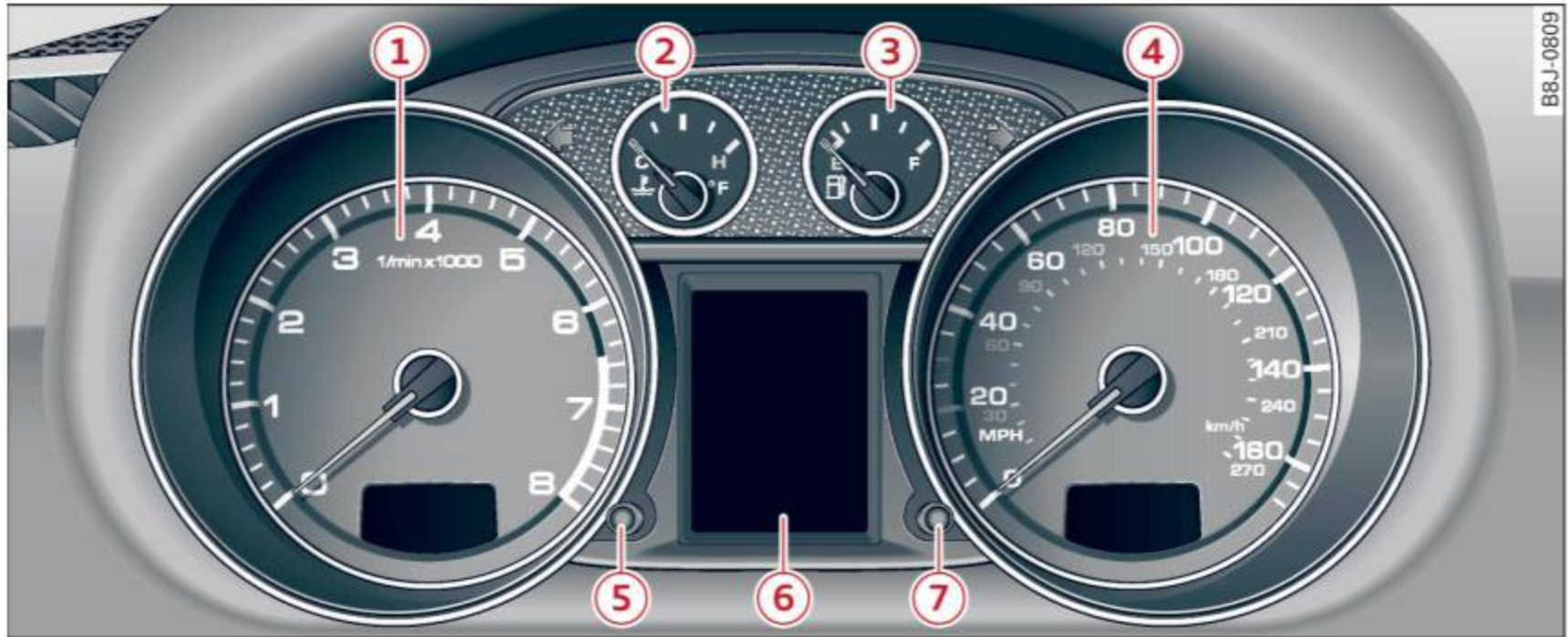

Fig. 3 Overview of the instrument cluster

- ① Tachometer with time and date display ..... 10, 11
- ② Coolant temperature gauge ... 11
- ③ Fuel gauge ..... 12
- ④ Speedometer with odometer .. 12
- ⑤ Set/Check button ..... 11
- ⑥ Driver information display .... 22
- ⑦ Reset button for
  - Trip odometer ..... 12
  - Service indicator ..... 28

### Tachometer (engine rev counter)

The tachometer indicates the engine RPM (revolutions per minutes).

If engine RPM drops below 1,500, you should downshift to the next lower gear. The red area at the end of the scale indicates maximum permissible engine RPM after the break-in period. Before reaching this area, move the selector lever to position “D (Drive)” or ease your foot off the accelerator pedal.

**i Tips**

- When switching the ignition on, the needles in the instrument cluster move upward briefly.
- The illumination for the instrument cluster lights up whenever you switch on the ignition with the **vehicle headlights off**. As the daylight fades, the instrument cluster illumination likewise dims automatically and will go out completely when the outside light is very low. This feature is meant to remind you to switch on the headlights when outside light conditions become poor.

**! Note**

The tachometer needle should only briefly be in the red zone: you could damage your engine! The beginning of the red zone varies depending on the engine.

**🌳 For the sake of the environment**

Upshifting early saves fuel and reduces engine noise.

### Digital clock with date display

Your vehicle is equipped with a quartz controlled digital clock.



Fig. 4 Instrument cluster with the digital clock

#### To set the hour

- ▶ Pull the knob (hour display flashes) and turn it to the left or right.

#### To set the minutes

- ▶ Pull the knob as many times as necessary until the minute display flashes.
- ▶ Turn the knob to the left or right.

#### To set the date

- ▶ Pull the knob as many times as necessary until the day, month or year display flashes.
- ▶ Turn the knob to the left or right.

#### To hide or display the date

- ▶ Pull the knob as many times as necessary until the date display flashes.
- ▶ Turn the knob to the left or right.

When the date display stops blinking, this means the time and date have been successfully stored.

With the ignition off, pushing or pulling the Set/Check button ⇒ *page 10, fig. 3* ⑤ can turn on the display field lighting for a few seconds.

### Engine coolant temperature gauge

The engine coolant gauge ⇒ *page 10, fig. 3* ② only works when the ignition is on. To prevent damage to your engine, please note the following important points:

#### Engine cold

As long as the needle remains at the left end of the gauge, the engine still has not reached its operating temperature. Avoid high engine speeds, heavy engine loads and heavy throttle.

#### Normal temperature

When the engine has reached its operating temperature, the needle will move into the middle of the gauge and remain there. If the engine is working hard at high outside temperatures, the needle may turn further to the right. This is no cause for concern as long as the  warning light in the instrument cluster does not illuminate.

When the  warning light starts to flash, this can mean one of two things: either the coolant *temperature* is too high, or the coolant *level* is too low ⇒ *page 16*.

#### WARNING

- Always observe the warning in ⇒ *page 174, Engine compartment* before opening the engine hood and checking the engine coolant level.
- Never open the engine hood if you see or hear steam, or if you see engine coolant dripping from the engine compartment. You could burn yourself. Let the engine cool off first until you can no longer see or hear steam or coolant escaping.

#### Note

- Mounting additional lights or accessories in front of the air inlets reduces the cooling effect of the radiator. At high outside temperatures or high engine load, the engine could overheat.
- The front spoiler has been designed to properly distribute the cooling air when the vehicle is moving. If the spoiler is damaged, this could reduce the cooling effect and the engine could then overheat. Ask your authorized Audi dealer for assistance.

## Fuel gauge

The fuel gauge works only when the ignition is on. When the needle reaches the red area, the warning light in the instrument cluster will illuminate ⇒ [page 20](#) . **Time to refuel!**

### Note

Never run the tank completely dry! An irregular supply of fuel can cause engine misfiring and fuel could enter into the exhaust system. The catalytic converter could then overheat and be damaged.

## Speedometer with odometer

The speedometer shows you the vehicle speed, and the odometer shows you how many miles (kilometers) you have driven.



Fig. 5 Speedometer close-up: odometer display

The distance driven is shown in miles (USA models) or in kilometers (Canada models).

### Lower odometer

The lower odometer shows the total number of miles (kilometers) driven.

### Upper odometer (trip odometer)

The upper odometer shows the total number of miles (kilometers) driven since you last reset the odometer back to zero. You can use this odometer when you want to keep track of how many miles (kilometers) you have driven for a single trip or errand. The last digit indicates 1/10 of a mile (100 meters). You can set the trip odometer back to zero by pressing the reset button ⇒ [fig. 5](#).

With the ignition off, pushing of the Set/Check button ⇒ [page 10, fig. 3](#)  can turn on the display field lighting for a few seconds.

### Malfunction message

If there is a malfunction somewhere in the instrument cluster, **dEF** will appear in the trip odometer and will stay on. Contact your authorized Audi dealer to have the problem corrected.

### Immobilizer

When the ignition is switched on, the data on the ignition key are scanned automatically.

If an unauthorized key was used, **SAFE** is displayed continuously in the odometer display field. The vehicle cannot be operated ⇒ [page 33](#).

## Warning/indicator lights

### Description

The indicator lights in the instrument cluster blink or turn on. They indicate functions or malfunctions ⇒ .

Messages may appear with some indicator lights. The messages turn off after a short time. To display a message again, press the Set/Check button ⇒ [page 10, fig. 3](#) . If there is more than one malfunction, the indicator lights will turn on one after the other for approximately two seconds each.

Some indicators lights in the display can turn on in several colors.

### WARNING

- Failure to heed warning lights and other important vehicle information may result in serious personal injury or vehicle damage.
- Whenever stalled or stopped for repair, move the vehicle a safe distance off the road, stop the engine, and turn on the emergency flasher ⇒ [page 45](#).

– The engine compartment of any motor vehicle is a potentially hazardous area. Before you check anything in the engine compartment, stop the engine and let it cool down. Always exercise extreme caution when working under the hood  
⇒ *page 174, Engine compartment*

**i Tips**

Malfunctions or faults will be identified either with a red symbol (priority 1 – Danger!) or with a yellow symbol (priority 2 – Warning).

**Overview**

Some indicator lights turn on briefly to check the function of that system when you switch the ignition on. These systems are marked with a ✓ in the following tables. If one of these indicator lights does not turn on, there is a malfunction in that system.

**Red indicator lights**

Red symbols indicate a priority malfunction - Danger!

- Pull off the road.
- Stop the vehicle.
- Turn off the engine.
- Check the malfunctioning system. Contact your authorized Audi dealer or a qualified workshop for assistance.













	<b>USA models:</b> Malfunction in the brake system ⇒ <i>page 14</i>
	<b>Canada models:</b> Malfunction in the brake system ⇒ <i>page 14</i>
	<b>USA models:</b> Airbag system ✓ ⇒ <i>page 15</i>
	<b>Canada models:</b> Airbag system ✓ ⇒ <i>page 15</i>
	Safety belt ⇒ <i>page 16</i>
	Generator ✓ ⇒ <i>page 16</i>

	Engine oil pressure too low ⇒ <i>page 16</i>
	Engine coolant level too low/ engine coolant temperature too high ⇒ <i>page 16</i>
	Electro-mechanical power assist ⇒ <i>page 17</i>
	Clutch is overheating ⇒ <i>page 85</i>





**Yellow indicator lights**

Yellow symbols indicate a priority 2 malfunction - Warning!

	Clutch pedal ⇒ <i>page 17</i>
	Electronic Stabilization Control (ESC) ✓ ⇒ <i>page 17</i>
	Electronic Stabilisation Control (ESC) ✓ ⇒ <i>page 17</i>
<b>ABS</b>	<b>USA models:</b> anti-lock brake system (ABS) ✓ defective ⇒ <i>page 18</i>
	<b>Canada models:</b> anti-lock brake system (ABS) ✓ defective ⇒ <i>page 18</i>
	Worn brake pads ⇒ <i>page 18</i>
	Tire pressure too low ⇒ <i>page 214</i>
<b>TPMS</b>	Tire pressure monitoring system ⇒ <i>page 215</i>
<b>EPC</b>	Electronic power control ✓ ⇒ <i>page 19</i>
	<b>USA models:</b> Malfunction Indicator Lamp (MIL) ⇒ <i>page 19</i>
	<b>Canada models:</b> Malfunction Indicator Lamp (MIL) ⇒ <i>page 19</i>
	Engine speed limitation* ⇒ <i>page 19</i>

	Check engine oil level ⇒ page 19
	Engine oil sensor malfunction ⇒ page 19
	Battery voltage too high or too low ⇒ page 19
	Low fuel level ⇒ page 20
	Windshield washer fluid level low ⇒ page 20
	Defective light bulb ⇒ page 20
	<b>USA models:</b> Defective brake light ⇒ page 20
	<b>Canada models:</b> Defective brake light ⇒ page 20
	Dynamic headlight range control* defective ⇒ page 20
	Adaptive Light* defective ⇒ page 20
	Light/rain sensor defective (automatic headlights)* defective ⇒ page 21
	Audi magnetic ride ⇒ page 21
	Rear spoiler ✓ ⇒ page 21
	<b>USA models:</b> Speed warning 1 ⇒ page 74
	<b>Canada models:</b> Speed warning 1 ⇒ page 74
	<b>USA models:</b> Speed warning 2 ⇒ page 74
	<b>Canada models:</b> Speed warning 2 ⇒ page 74
	Electro-mechanical power assist ⇒ page 17

### Other indicator lights

	Turn signals ⇒ page 21
	
	<b>USA models:</b> Cruise control acti- vated ⇒ page 21
	<b>Canada models:</b> Cruise control activated ⇒ page 21
	High beam ⇒ page 44

### **BRAKE/ (P) Brake system**

This warning/indicator light illuminates when the brake fluid level is too low or when there is a malfunction in the ABS, or when the parking brake is set.



If the **BRAKE** (USA models)/ (Canada models) symbol flashes in the display with the parking brake released, there is a malfunction in the brake system. In addition to the symbol, one of two messages appears in the display:

#### **Stop vehicle and check brake fluid level**

#### **Stabilization program and ABS fault! See Owner's manual**

- ▶ Pull off the road and stop the vehicle.
- ▶ Obtain professional assistance.

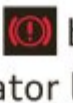

*USA models:* if there is a malfunction in the ABS system, the **ABS** warning/indicator light illuminates along with the **BRAKE** system malfunction warning/indicator light ⇒ .

*Canada models:* if there is a malfunction in the ABS system, the  warning/indicator light illuminates together with the  brake system malfunction warning/indicator light ⇒ .

The light **BRAKE** (USA)/ (Canada) illuminates when the ignition is turned on. It goes out after the engine has been started and the parking brake is fully released. This indicates ▶

that the brake warning light is functioning properly.

**If the brake warning light does not light up when the engine is cranking or the parking brake is applied, there may be a malfunction in the electrical system. In this case, contact your Audi dealer.**

If the ABS fails, the ABS warning/indicator light **ABS** (USA models) /  (Canada models) flashes together with the brake system warning/indicator light ⇒ .

(USA models): If the warning light **BRAKE** and the warning light  illuminate together, immediately contact your authorized Audi dealer or qualified workshop to have all brake pads inspected ⇒ *page 18*.

When the light comes on, an audible warning signal is also given.

### Parking brake set

The parking brake warning light **Brake** /  (Canada models) illuminates when the parking brake is set. In addition, a warning tone will sound after you have driven for longer than 3 seconds and faster than 3 mph (5 km/h).



### Parking brake set

The **BRAKE** warning/indicator light illuminates when the parking brake is set ⇒ .

#### WARNING



- Always observe the warnings in ⇒ *page 174, Engine compartment*, before opening the engine hood and checking the brake fluid.
- Driving with low brake fluid is a safety hazard! Stop the car and get professional assistance.
- *USA models*: If both, the **BRAKE** warning light and the **ABS** warning light come on at the same time, the rear wheels could lock up first under hard braking. Lock-up of the rear wheel brakes can cause loss of vehicle control and an accident. Have your vehicle repaired immedi-

ately by your authorized Audi dealer or a qualified workshop. Drive slowly and avoid sudden, hard brake application.

- *Canada models*: If both, the brake warning light  and the ABS warning light  come on at the same time, the rear wheels could lock up first under hard braking. Lock-up of the rear wheel brakes can cause loss of vehicle control and an accident. Have your vehicle repaired immediately by your authorized Audi dealer or a qualified workshop. Drive slowly and avoid sudden, hard brake application.
- If the brake warning/indicator light does not go out after a few seconds and the parking brake is released, or lights up while you are driving, the fluid level in the brake fluid reservoir is too low. If you believe that it is safe to do so, proceed immediately at low speed to the nearest authorized Audi dealer or qualified workshop and have the brake system inspected.
- Always keep in mind that after several brake applications, you will need greater pressure on the brake pedal to stop your vehicle. Do not rely on strained brakes to respond with maximum stopping power in critical situations. You must allow for increased braking distances. The extra distance used up by fading brakes could lead to an accident.

#### **Safety systems**

The  (USA models) /  (Canada models) indicator light monitors the safety systems e.g. (airbags, pretensioners) and illuminates for a few seconds each time you switch the ignition on.

If the  (USA models) /  (Canada models) indicator light does not go out, or if it illuminates while you are driving, or if it starts to blink, then there is a malfunction somewhere in the system. If the light does not illuminate when you switch on the ignition, this also means there is a malfunction. ▶

**⚠ WARNING**

If you have a malfunction in the safety systems, contact your authorized Audi dealer immediately. Otherwise the safety systems may not work properly in an accident.

**🚗 Safety belt warning light**

Applies to vehicles: with safety belt warning light

*The warning light is a reminder to fasten safety belts.*

The warning light  comes on for a few seconds after the ignition is switched on as a reminder to fasten your safety belt.

Additional information on safety belts  
⇒ *page 100.*

**🔌 Generator**

*This warning/indicator light detects a malfunction in the generator or in the vehicle's electrical system.*

The  warning/indicator light illuminates when you switch on the ignition and must go out after the engine has started.

If the  warning/indicator light illuminates while you are driving, you should contact your authorized Audi dealer. Since the vehicle battery is discharging, you should switch off any unnecessary electrical consumers (for example, the air conditioner).

**🛢 Engine oil pressure**

*The red engine oil pressure warning symbol requires immediate service or repair.*

If the  symbol appears in the display and flashes, the oil pressure is too low. In addition to the symbol, the following message also appears in the display:

**Switch off engine! Oil pressure is too low**

- ▶ Pull off the road and stop the vehicle.
- ▶ Shut the engine down.
- ▶ Check the engine oil level ⇒ *page 185.*

- ▶ Contact your authorized Audi dealer for assistance if necessary.





**Engine oil level too low**

If the engine oil level is too low, top off oil to the proper level ⇒ *page 185.*

**Engine oil level OK**

If the  symbol starts flashing again even though the engine oil level checks OK on the dipstick, **do not start driving again and do not let the engine run at idle.** Instead, contact your authorized Audi dealer for assistance.

**i Tips**

- The engine oil pressure symbol  is not an indicator for a low engine oil level. Do not rely on it. Instead, check the oil level in your engine at regular intervals, preferably each time you refuel, and always before going on a long trip.
- The yellow oil level warning indication  requires oil refill or workshop service without delay. Do not wait until the red oil pressure warning symbol  starts to flash before you respond to the low oil level warning . By then, your engine may already have suffered serious damage.

**🌡 Engine cooling system**

*A malfunction in the engine cooling system must be repaired as soon as possible.*

When the  symbol in the display flashes, then either the engine coolant *temperature* is too high, or the coolant *level* is too low. In addition to the symbol, the following message also appears in the display:

**Switch off engine and check coolant level**

- ▶ Pull off the road and stop the vehicle.
- ▶ Turn off the engine.
- ▶ Check coolant level ⇒ *page 187.*
- ▶ Add coolant if necessary ⇒ *page 188.*
- ▶ Continue driving only after the engine coolant warning/indicator light goes out. ▶

- ▶ Contact your authorized Audi dealer for assistance if necessary.

If the engine coolant level is correct, then the radiator fan may be the cause of the malfunction.

If the generator warning/indicator light should also illuminate ⇒ *page 16*, then the fan belt may be damaged.



### WARNING

- If your vehicle should break down for mechanical or other reasons, park at a safe distance from moving traffic, turn off the engine and turn on the hazard warning lights ⇒ *page 45, Emergency flasher* .
- Never open the hood if you see or hear steam or coolant escaping from the engine compartment - you risk being scalded. Wait until you can no longer see or hear steam or coolant escaping.
- The engine compartment of any vehicle is a dangerous area. Before you perform any work in the engine compartment, turn off the engine and allow it to cool. Follow the warning stickers ⇒ *page 180*.

### Note

Do not continue driving if the  symbol illuminates. There is a malfunction in the engine cooling system – you could damage your engine.

### Electro-mechanical power assist

If the indicator light illuminates while you are driving, there is a malfunction in the electro-mechanical steering. If the indicator light is showing , there may be a reduction in power steering assist. If the indicator light is showing , there may be a total loss of power steering assist. The steering must be inspected immediately by a qualified workshop ⇒ . With the engine not running (e.g. when the car is being towed), there is also no power assist available.

### WARNING

If there is a malfunction, the indicator light for the electro-mechanical power assist illuminates. Seek professional assistance.

### Clutch pedal



Applies to vehicles: with manual transmission

The indicator light  illuminates if you do not press the clutch pedal when starting the engine. For safety reasons, the engine will only start when the clutch pedal is pressed.



### Electronic Stabilization Control (ESC)

If the  indicator lamp blinks while driving, the ESC or ASR (Anti-Slip Regulation) is actively regulating.

If the  indicator lamp illuminates, the system has switched the ESC off. In this case, you can switch the ignition off and then on to switch the ESC on again. The system is functioning completely when the indicator lamp switches off.

If the  indicator lamp illuminates, the ESC was switched off with the  button.

**Stabilization program and ABS fault! See owner's manual**

If the  indicator lamp and the  ABS indicator lamp illuminate and the driver message appears, the ABS or electronic differential lock is malfunctioning. This also interrupts the ESC. The brakes still function with their normal power, but ABS is not active.

Drive to your authorized Audi dealer immediately to have the malfunction corrected.

For more information about the ESC ⇒ *page 150*.

**ABS/  Anti-lock brake system**

This warning/indicator light monitors the ABS and the electronic differential lock (EDL).

The warning/indicator light **ABS** (USA models) /  (Canada models) will come on for a few seconds when the ignition is switched on. The light will go out after an automatic check sequence is completed.

**There is a malfunction in the ABS when:**

- The warning/indicator light does not illuminate when you switch the ignition on.
- The warning/indicator light does not go out after a few seconds.
- The warning/indicator light illuminates while driving.

The ESC indicator light also illuminates if there is a malfunction in the ABS. The message **Stabilization program and ABS: fault!** **See owner's manual** also appears in the instrument cluster display and a warning tone sounds.

**The brake system will still respond even without the assistance of the ABS system. See your authorized Audi dealer as soon as possible to restore full braking performance.**

For more information regarding the ABS ⇒ *page 150*.

**Malfunction in the brake system**

If the brake warning light ⇒ *page 14* and the ABS warning illuminate *together* there may be a malfunction in the ABS, and there may also be a malfunction in the brake system itself ⇒ . **The ABS will not work and you will notice a change in braking response and performance.**





In the event of a **malfunction in the brake system** the warning/indicator light **BRAKE** (USA models) /  (Canada models) in the instrument cluster flashes ⇒ *page 14*.

**Malfunction in the electronic differential lock (EDL)**

The EDL works together with the ABS. The ABS warning light will come on if there is a

malfunction in the EDL system ⇒ *page 150*. See your authorized Audi dealer as soon as possible.

** WARNING**

- If the **ABS** (USA models) /  (Canada models) warning light does not go out, or if it comes on while driving, the ABS system is not working properly. The vehicle can then be stopped only with the standard brakes (without ABS). You will not have the protection ABS provides. Contact your Audi dealer as soon as possible.
- *USA models:* If the **BRAKE** warning light, the  warning light and the **ABS** warning light come on together, the rear wheels could lock up first under hard braking. Rear wheel lock-up can cause loss of vehicle control and an accident. Have your vehicle repaired immediately by your authorized Audi dealer or a qualified workshop. Drive slowly and avoid sudden, hard brake applications.
- *Canada models:* If the brake warning light , the  warning light and the ABS warning light  come on together, the rear wheels could lock up first under hard braking. Rear wheel lock-up can cause loss of vehicle control and an accident. Have your vehicle repaired immediately by your authorized Audi dealer or a qualified workshop. Drive slowly and avoid sudden, hard brake applications.

** Worn brake pads**** Check brake pads!**

If the warning light illuminates, immediately contact your authorized Audi dealer or qualified workshop to have all brake pads inspected. On USA models the warning light  comes on together with the warning light **BRAKE**. Both sets of brake pads on an axle must always be replaced at the same time. ►

**! WARNING**

Driving with bad brakes can cause a collision and serious personal injury.

- If the warning light  and the warning light **BRAKE**<sup>1)</sup> with the message **Brake pads!** comes on in the instrument cluster display, immediately contact your authorized Audi dealer or qualified workshop to have all brake pads checked or replaced if necessary.

**EPC Electronic power control**

*This warning/indicator light monitors the electronic power control.*

The **EPC** warning/indicator light (Electronic Power Control) illuminates when you switch on the ignition as a function check.

**i Tips**

If this warning/indicator light illuminates while you are driving, then there is a malfunction in the engine electronics. Have the malfunction corrected as soon as possible by your authorized Audi dealer or qualified workshop.

** Malfunction Indicator Lamp (MIL)**

The Malfunction Indicator Lamp (MIL) is part of the On-Board Diagnostic (OBD II) system. The symbol  lights up when the ignition is turned on and will turn off after the engine has started and has settled at constant idle speed. This indicates that the MIL is working properly.

The warning light illuminates when there is a malfunction in the engine electronic system. Contact your authorized Audi dealer and have the malfunction corrected.

**An improperly closed fuel filler cap may also cause the MIL light to illuminate**

⇒ *page 178.*

For more information ⇒ *page 30.*

** Engine speed limitation**

Applies to vehicles: with engine speed limitation

** Do not exceed max. engine speed of XXXX rpm**

The  symbol illuminates when there is an engine control malfunction. The indicator light **EPC** in the instrument cluster also illuminates. The engine speed is limited to the speed displayed in the driver information system. Keep in mind that the engine speed will not exceed the value displayed in the driver information system, for example when downshifting.

Please go to an authorized Audi dealer or other qualified workshop to have the malfunction repaired.

** Checking the engine oil level**** Please add max. 1 qt of engine oil!**

If the  symbol comes on, add 1 quart (1 liter) of oil at the next opportunity  
⇒ *page 185.*

** Engine oil sensor defective**

If the  symbol illuminates, contact your authorized Audi dealer and have the oil sensor inspected.

** Battery voltage low**** Low battery charge: battery will be charged while driving**

If the indicator light turns on and the message appears, there may be limited starting ability.

If this message turns off after a little while, the battery charged enough while driving.

If the message does not turn off, have your authorized Audi dealer or qualified workshop correct the malfunction.

1) **BRAKE**: USA models only

** Fuel supply too low**

When the  symbol illuminates, this means there are about 1.9 gallons (7 liters) of fuel left in the fuel tank. Time to refuel!

⇒ page 177.

If the symbol lights up, even when there is ample fuel in the tank, and the text **Tank system malfunction! Please contact workshop** appears in the display, there is a fault in the system. Contact a qualified workshop to have the fault rectified.

** Windshield washer fluid level too low**

If the  symbol illuminates, add windshield washer fluid to the washer system

⇒ page 194.

** Defective light bulb warning**

*The defective light bulb warning tells you when a vehicle light bulb has become defective.*

If a defective bulb has been detected by the system or a light bulb burns out, the  symbol with a message appears in the display to tell you which bulb is burnt out and where it is located. For example:

**Rear left turn signal**

After 5 seconds, the message disappears. If you want to recall the message into the display, press the CHECK button ⇒ page 10, fig. 3 .

There are three reasons why the defective bulb message would appear in the display:

- The light bulb has burnt out ⇒ page 231.
- The fuse is “blown” ⇒ page 228, *Replacing fuses*.
- The wire connection to the light bulb is defective.

Have the bulb replaced or the connection repaired by your authorized Audi Service department.

** WARNING**

- Light bulbs are pressurized and could explode while they are being changed causing serious personal injury.
- Work with due care when handling the high-voltage section of gas discharge (xenon) lamps. Failing to do so could result in death or serious injury!

** BRAKE LIGHT/  Brake light defective**

In case of a malfunction or component failure, the symbol **BRAKE LIGHT** (USA models)/  (Canada models) can appear. The following electrical components should be checked, repaired or replaced, as necessary:

- Brake light bulbs
- All wiring connections
- Brake light switch

Contact your authorized Audi dealer for assistance if necessary.

** Tips**

The brake light switch is only inspected as part of the functional check after the engine is started.

** Headlight range control defective**

Applies to vehicles: with dynamic headlight range adjustment

If the  illuminates, the dynamic headlight range control is no longer working properly. Have the system checked and repaired at your authorized Audi dealer.

** Adaptive light defective**

Applies to vehicles: with Adaptive Light

** Adaptive light defective**

When this symbol  illuminates, it means that Adaptive Light is defective. Go to a qualified workshop to have the headlights or the control unit for the Adaptive Light repaired.

### Light/rain sensor defective

Applies to vehicles: with automatic headlights

*The indicator light indicates a defect in the automatic headlights/automatic wiper system.*

If the symbol illuminates, the light sensor has failed. For safety reasons, the low beams are turned on permanently with the switch in **AUTO**. However, you can continue to turn the lights on and off using the light switch. In the case of a defect in the rain sensor, the windshield wiper lever functions are still available. Have the light/rain sensor checked as soon as possible at an authorized Audi dealer.

### Audi magnetic ride

Applies to vehicles: with Audi magnetic ride

*The indicator light monitors vehicle damping.*

The indicator light  illuminates when the ignition is switched on as a function check.

### Tips

If the indicator lamp illuminates while you are driving, there is a malfunction in the vehicle damping. The chassis should be inspected immediately by an authorized Audi dealer.

### Rear spoiler

*The warning/indicator light monitors the electrically retractable rear spoiler.*



The warning/indicator light  has the following functions:

- It comes on for about 3 seconds as a function check when the ignition is switched on.
- It comes on if there is a malfunction in the electrically retractable rear spoiler.

Additional information about the electrically retractable rear spoiler ⇒ *page 153*.

### Turn signals

*The indicator light blinks when you use either turn signal.*

Whenever you use the left  or the right  turn signal, the indicator light blinks. When you use the emergency flasher, both indicator lights flash.

If one of the turn signal light bulbs burn out, the turn signal will blink twice as fast as normal.

Additional information on the turn signals ⇒ *page 44*.

### **CRUISE/** Cruise control

The **CRUISE** (USA models)/  (Canada models) warning/indicator light illuminates when the cruise control is activated.

# Driver information system

## Introduction

The Driver information display inside the instrument cluster provides you, the driver, with important information.



Fig. 6 Instrument cluster: center display



Fig. 7 Wiper lever: controls for the menu display

### Center display

With the ignition on, the display in the Driver Information System shows the following information:

- CD\* inserted or Radio\* station set
- Outside temperature\*: At temperatures below 41 °F (+5 °C), a snowflake symbol appears in front of the temperature display ⇒ .
- Warning: front lid, door or engine compartment lid open: The display appears if the door, the engine compartment lid or front lid is not closed.

### Additional functions

You can open the following functions in the Driver Information System display by pressing the **RESET** button ⇒ *fig. 7* one or more times:

Digital speedometer*	
Tire pressure monitoring	⇒ page 214
Trip computer	⇒ page 23
Menu display	⇒ page 24
Efficiency program	⇒ page 26
Service interval display	⇒ page 28
Lap timer*	⇒ page 29
Speed warning	⇒ page 74

### Auto Check Control

Some functions and vehicle components are scanned for their operating status when you switch the ignition on and while you are driving. Malfunctions or required service procedures are signaled audibly and indicated by red and yellow illuminated symbols and reminders in the display.

#### WARNING

- Never rely exclusively on the outside temperature display to determine if a road surface is icy or not. Keep in mind that road surfaces, especially bridges and overpasses, could be ice covered and slippery even at an outside temperature above 41 °F (+5 °C).
- Always remember, even if the “snowflake” symbol (ice warning) does not appear in the display, black ice could be on the road.
- Always reduce your speed and drive with special care in cold weather conditions when the chance of encountering icy road surfaces increases.

#### Tips

- If the vehicle is stationary, or if you are driving at a very low speed, the temperature shown in the display might be slightly higher than the actual outside temperature. This is caused by the heat being radiated from the engine.
- On vehicles with Audi Navigation system\*, the displays may differ from their normal appearance during navigation.

## Trip computer

### Introduction

The trip computer gives you information on current and average fuel mileage, average speed, fuel range and driving time.



Fig. 8 Trip computer 1

The following information is continuously evaluated by the trip computer and can be displayed sequentially in the instrument cluster display:

### Fuel range

The estimated cruising range in miles (km) appears in the display. The display changes in increments of 6 miles (10 km).

### Average fuel mileage

The average fuel economy in MPG (l/100 km) since you last cleared the memory appears in this display.

### Current fuel mileage

The instantaneous fuel consumption in miles per gallon (l/100 km) is shown in this display. When the vehicle is stationary, the most recent fuel consumption is displayed.

### Average speed

The average speed in mph (km/h) since the last time the display was reset appears in the display.

### Elapsed time

The length of time that you have been driving since you last reset the memory appears in this display. The maximum time period that can be recorded is 999 hours and 59 minutes.

### Distance

The elapsed distance since the last time the memory was cleared appears in the display. The maximum distance that can be recorded is 9,999.9 miles (9,999.9 kilometers).

### Tips

- Fuel consumptions (average and current), range and speed are displayed in metric units on Canadian models.
- All stored values will be lost if the vehicle battery is disconnected.

### Memories

The trip computer is equipped with two fully automatic memories as well as an efficiency program.

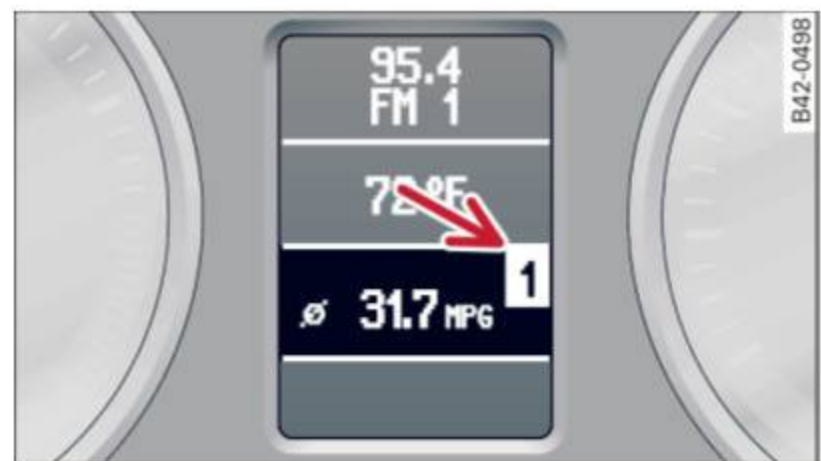



Fig. 9 Trip computer display: memory level 1

You can switch between the trip computer 1 and 2 and the efficiency program\* by pressing the **RESET** button  ⇒ page 24, fig. 10.

You can tell which memory level is currently active by the number or the sign in the display ⇒ fig. 9. The data from the single-trip memory (memory level 1) is being displayed if a **1** appears in the display. If a **2** is shown, then the data from the total-trip memory is being displayed (memory level 2). The fuel pump nozzle  indicates the efficiency program\* ⇒ page 26.

### Single-trip memory (Trip computer 1)

The single-trip memory stores the trip information from the time the ignition is turned on until it is turned off. If the trip is continued **within 2 hours** from the time the ignition was turned off, the new data will be included in

the calculation of the current trip information. If the trip is interrupted for **more than 2 hours** the memory is reset automatically.

### Total-trip memory (Trip computer 2)

Unlike the single-trip memory, the total-trip memory is not reset automatically. This permits you to evaluate your driving data for the entire period between manual resets.

### Efficiency program\*

The efficiency program can help you to use less fuel ⇒ *page 26*.

## Operation

The trip computer is controlled by two switches on the windshield wiper lever.



Fig. 10 Wiper arm/wiper lever: controls for the trip computer

### Selecting the trip computer

- ▶ Tap the **Reset** button (B) until the trip computer (memory level 1 or 2) appears in the display ⇒ *page 23, fig. 8*.

### Selecting the functions

- ▶ Push in the upper (lower) protrusion on the function selector switch (A) ⇒ *fig. 10*. The functions for the trip computer are displayed in succession on the respective memory levels.

### Resetting the function to zero

- ▶ Push the **Reset** button (B) for at least two seconds.

You can reset the following values to zero using the **Reset** button:

- driving time

- distance
- average fuel mileage
- average speed

The trip computer only operates when the ignition is on. When you turn on the ignition, the function that was in use when you last turned the ignition off will be displayed.

### **i** Tips

- You can also set the values for the functions to zero in the menu display (**Reset**) ⇒ *page 24*.
- All stored values will be lost if the vehicle battery is disconnected.
- The driving information in the efficiency program is also reset to zero with the single-trip memory.

## Menu display

### Introduction



Fig. 11 Display: Start menu

Some functions in your vehicle can be set, activated, and controlled by **Menus** (e.g. Acoustic park assist\*). With these menus you can also select the information shown in the driver information system, which operates only with the ignition switched on. Operation is controlled by the **Reset** button and the rocker switch on the wiper lever ⇒ *page 25, fig. 12*.

The **Start menu** shows you the different display types:

**Set**

**Check**

**Menu off**

Each display type in the Start menu contains a submenu with additional options.

<b>Set</b>	Clock ⇒ page 26
	Computer ⇒ page 26
	Acoustic park assist* ⇒ page 78
	Speed warning ⇒ page 76
	Language ⇒ page 26
	Units (distance, fuel consumption, temperature) ⇒ page 26
	Tire pressure monitoring ⇒ page 214
	Lap timer* ⇒ page 29
	Lighting* ⇒ page 42
	Wiper (service position) ⇒ page 50
	Window ⇒ page 40
	Doors (unlocking and locking mode, for example Auto-lock) ⇒ page 34, ⇒ page 34
	<b>Check</b>
	Chassis number ⇒ page 238
	Engine oil temperature* ⇒ page 26, ⇒ page 28
	Registered keys ⇒ page 32
<b>Menu off</b>	All of the messages shown in vehicles without menu display appear on the display screen.

### Navigating the menu

Use the rocker switch on the windshield wiper lever and the **Reset** button to operate the menu and carry out inquiries and selections.



Fig. 12 Wiper lever: Controls for the menu display



Fig. 13 Display: Start menu

**Reset** button (B) and **rocker switch** (A) ⇒ fig. 12 functions:

#### To open the menu

- ▶ Press the **Reset** button (B) until the menu display ⇒ fig. 13 appears

#### Selections and settings

- ▶ Press the rocker switch (A) to reach a menu display. The switch is operated the same as the display (up/down).

#### Entering and confirming

- ▶ Press the **Reset** button (B).

#### Returning to the Start menu

- ▶ Press the **Reset** button longer than 2 seconds to return from any menu level to the Start menu.

Using the rocker switch, you can select the menus in the display or change settings. A cursor appears on the left in front of the selected values.

By pressing the **Reset** button, you activate the selection you made or confirm the values you set. **Selected** functions are identified with a check mark or are carried out directly.

Meanings of the symbols in the display:

Selection bar	Selected function	Meaning
>	Cursor	Current Selection
✓	Check mark	Selected or Function active

<input type="checkbox"/>	Box	Not selected
▲	Triangle pointing up	Previous page
▼	Triangle pointing down	Next page

**Selecting settings**

The Driver Information System settings are menu-guided.



Fig. 14 Display: Menu Settings, computer selected (page 1)

Select your settings as follows:

- ▶ Press the **Reset** button. The Start menu appears ⇒ page 24, fig. 11.
- ▶ Press the rocker switch until **Set** is displayed.
- ▶ Press the **Reset** button. All the menus appear.
- ▶ Press the rocker switch until the desired line is highlighted (cursor) ⇒ fig. 14.
- ▶ Press the **Reset** button.
- ▶ If necessary, scroll by selecting and activating the symbol for “Next page” or “Previous page”.

When you have selected the Computer menu and activated it by pressing the **Reset** button, two computer levels appear (computer 1 and computer 2). Now you have to select the level you want using the rocker switch and activate it with the **Reset** button.



**Engine oil temperature display**

Applies to vehicles: with engine temperature control display



Fig. 15 Display: engine oil temperature display

- ▶ With the ignition switched on, press the **RESET** button ⇒ page 24, fig. 10 repeatedly until the engine oil temperature display is shown.

The engine has reached its operating temperature when the engine oil temperature is between **176 °F** (80 °C) and **248 °F** (120 °C) under normal driving conditions. The engine oil temperature may be higher if there is heavy engine load and high temperatures outside. This is not a cause for concern as long as the  ⇒ page 16 or  ⇒ page 19 warning light in the display does not flash.

**Efficiency program**

**Description**

Applies to vehicles: with trip computer with efficiency program



Fig. 16 Display: efficiency program

- ▶ Press the **RESET** button  ⇒ page 24, fig. 10 repeatedly until the efficiency program appears in the display.

The efficiency program can help you to use less fuel. It evaluates driving information in reference to fuel consumption and shows other equipment influencing consumption as well as shift recommendations. Fuel economy messages ⇒ *page 27* provide tips for efficient driving.

The efficiency program uses distance and consumption data from trip computer 1. If the data are deleted in the efficiency program, those values are also reset in trip computer 1.

### Other equipment

Applies to vehicles: with trip computer with efficiency program



Fig. 17 Display: other equipment

- ▶ In the efficiency program, press the function selection switch ⇒ *page 24, fig. 10 (A)* repeatedly until the other equipment appears in the display.

Other equipment that is currently affecting fuel consumption is listed in the efficiency program. The display shows up to three other items of equipment (B). The equipment using the most fuel is listed first. If more than three items using fuel are switched on, the equipment that is currently using the most fuel is displayed.

A scale (A) also shows the current total consumption of all other equipment.

### Fuel economy messages

Applies to vehicles: with trip computer with efficiency program



Fig. 18 Display: fuel economy message

Fuel economy messages are displayed when fuel consumption is increased by certain conditions. If you follow these fuel economy messages, you can reduce your vehicle's consumption of fuel. The messages appear automatically and are only displayed in the efficiency program. The fuel economy messages turn off automatically after a certain period of time.

- ▶ To turn a fuel economy message off immediately after it appears, press the **RESET** button ⇒ *page 24, fig. 10 (B)*, or
- ▶ Press the function selection switch ⇒ *page 24, fig. 10 (A)*.

### **i** Tips

- Once you have turned a fuel economy message off, it will only appear again after you turn the ignition on again.
- The fuel economy messages are not displayed in every instance, but rather in intervals over a period of time.

## Service interval display

The service interval display reminds you when your next service is due.



Fig. 19 Section of instrument cluster: Service interval display

The schedule for the next oil change or inspection is calculated automatically and displayed accordingly. The display works in two stages:

### Service reminder

30 days before the next service is due, a service reminder appears in the display when you turn on the ignition.

After about 5 seconds the display switches back to normal. The distance and time remaining are updated each time the ignition is turned on until the date due for service is reached.

### Service due

When the due date for service is reached, the message **Service due!** appears in the instrument cluster immediately after you turn on the ignition. Additionally, a warning tone sounds. After about 5 seconds the display switches back to normal.

### Calling up the service schedules

If or when an oil change or inspection is due, can be shown in the instrument cluster by selecting the service interval display. Select **Check > Service > Oil change** or **Service** by using the **RESET** button and the rocker switch ⇒ page 25, fig. 12.

### Resetting the service interval display

Your authorized Audi dealer will reset the corresponding service schedule after performing

the appropriate service on your vehicle. You also have the possibility to reset the oil change schedule after having performed an oil change according to Audi specifications.

- Switch the ignition on.
- Pull the knob ⇒ fig. 19. The message. **Service due!** appears.
- Pull the knob until the display **Oil change in ----- mi (km)--- days** appears. If the **RESET** button is not pulled within 5 seconds, the display reset mode closes.

### ! Note

If you disconnect the battery terminals, no calculations can be made for the service interval display during this time and no service reminder will appear. Remember that observing the proper service intervals is vitally important to extending the life of your vehicle, particularly the engine, and maintaining its value. Even if the mileage driven is low, the maximum period of one year from one service to the next must not be exceeded.

### i Tips

- Do not reset the display between oil changes, otherwise the display will be incorrect.
- The information in the Service Reminder remains stored even when the vehicle battery is disconnected.

## Boost and engine oil temperature indicator

Applies to vehicles: with boost pressure indicator



Fig. 20 Display: boost and engine oil temperature indicator



- ▶ With the ignition switched on, press the button -arrow- repeatedly until the display is shown.

### Boost pressure indicator (boost)

A bar graph that begins on the left and fills in toward the right indicates the engine's current load (meaning the current boost pressure).

### Engine oil temperature indicator

If the engine oil temperature is below 140 °F (60 °C), the  symbol followed by three hyphens " - - - " and the °C unit is shown.

The engine has reached its operating temperature when the engine oil temperature is between 176 °F (80 °C) and 248 °F (120 °C) under normal driving conditions. The engine oil temperature may be higher if there is heavy engine load and high temperatures outside. This is not a cause for concern as long as the  ⇒ page 16 or  ⇒ page 19 warning light in the display does not flash.

## Lap timer

### Introduction

Applies to vehicles: with lap timer

You can record and evaluate lap times with the lap timer in the display ⇒ page 29, fig. 22. The time is measured in minutes, seconds and 1/10 seconds. The hours are also shown when the lap time exceeds 60 minutes. The maximum individual measurement is 99 hours.

### WARNING

Please devote your full attention to driving. As the driver, you have complete responsibility for safety in traffic. Only use the functions in such a way that you always maintain complete control over your vehicle in all traffic situations.

### Tips

When the lap timer stopwatch is running, you can call up the trip computer information with the **RESET** button.

### Calling up the lap timer and timing

Applies to vehicles: with lap timer



Fig. 21 Controls

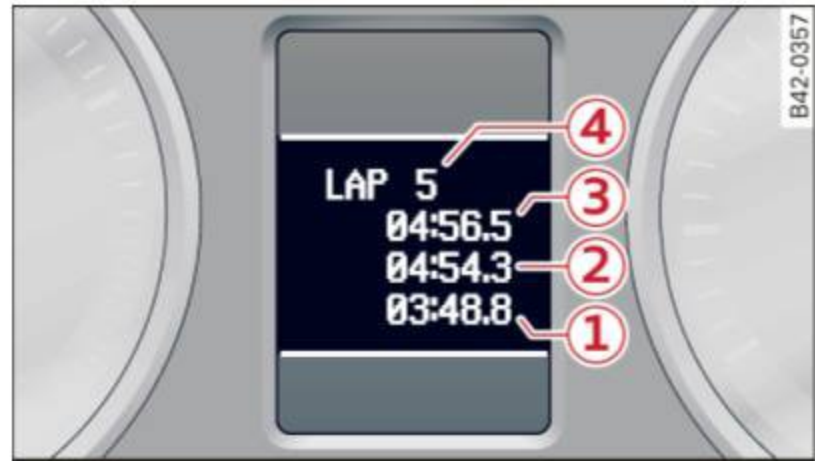

Fig. 22 Display: Lap timer

### Calling up the lap timer

- ▶ Press the **RESET** ⇒ fig. 21 **B** button until the lap timer ⇒ fig. 22 appears.

### Timing laps

- ▶ To start timing, press the upper section of the wiper switch **A**. The time measurement is shown in line **1** ⇒ fig. 22.
- ▶ To stop timing, press the upper section of the wiper switch **A** again. This also starts timing the next round. The previous time moves one line up, first to line **2** and then to line **3**. Line **4** shows the current lap number, for example LAP 5.

### Displaying intermediate time and pausing timing

- ▶ To display an intermediate time, press the lower section of the wiper switch (A). The intermediate time appears in line (1) and is marked with \*.
- ▶ To pause timing, press the lower section of the wiper switch (A) again.
- ▶ To continue timing, press the upper section of the wiper switch (A).

If timing is paused, you can continue it later even if you switch the ignition off.

### Evaluating times and continuing or resetting timing

Applies to vehicles: with lap timer

You can evaluate the fastest, slowest and average lap times.



Fig. 23 Display: lap time evaluation

- ▶ To evaluate lap times, press and hold the **RESET** ⇒ page 29, fig. 21 (B) button for approximately 2 seconds. The display shows the fastest lap "+", the slowest lap "-" and the average lap time "Ø".
- ▶ To continue timing for additional laps, press the wiper switch (A).
- ▶ To reset the timer to zero, press and hold the **RESET** button again for approximately 2 seconds.
- ▶ To switch the lap timer off completely, press the **RESET** button briefly.

#### **i** Tips

- Saved lap times cannot be individually deleted from the total results.
- The saved lap timer values will not be lost after turning the ignition off.

## On-Board Diagnostic system (OBD)

### Malfunction Indicator Lamp (MIL)

The Malfunction Indicator Lamp (MIL)  in the instrument cluster is part of the On-Board Diagnostic (OBD II) system.

The warning/indicator light illuminates when the ignition is switched on and goes out after the engine starts and the idle has stabilized. This indicates that the MIL is working properly.

**If the light does not go out** after the engine is started, or illuminates while you are driving, a malfunction may exist in the engine system. If the light illuminates, the catalytic converter could be damaged.

Continue driving **with reduced power** (avoiding sustained high speeds and/or rapid accelerations) and have the condition corrected. Contact your authorized Audi dealer.

If the light illuminates, the electronic speed limiter may also be malfunctioning. For more information ⇒ page 31, *Electronic speed limiter*.

**An improperly closed fuel filler cap may also cause the MIL light to illuminate** ⇒ page 178.

### On-Board Diagnostics



Fig. 24 Location of Data Link Connector (DLC)

On-Board Diagnostics monitors the components of your emission control system. Each monitored component in your engine system has been assigned a code. In case of a

malfunction, the component will be identified and the fault stored as a code in the control module memory.

The MIL light may also illuminate if there is a leak in the on-board fuel vapor recovery system. If the light illuminates after a refuelling, stop the vehicle and make sure the fuel filler cap is properly closed ⇒ *page 178*.

In order to make an accurate diagnosis, the stored data can only be displayed using special diagnostic equipment (generic scan tool for OBD).

In order to connect the special diagnostic equipment, push the plug into the Data Link Connector (DLC). The DLC is located to the right of the hood release ⇒ *fig. 24*.

Your authorized Audi dealer or a qualified service station can interpret the code and perform the necessary repair.

#### **WARNING**

Do not use the diagnostic connector for personal use. Incorrect usage can cause malfunctions, which can increase the risk of a collision!

### Electronic speed limiter

Your vehicle may be factory equipped with tires that are rated for a maximum speed of 130 mph (210 km/h). This is less than the maximum speed of your vehicle. To reduce the risk of sudden tire failure and loss of control if the vehicle is operated at excessive speeds, your vehicle also has an electronic speed limiter. The electronic speed limiter prevents your vehicle from going faster than the tire speed rating. For more information ⇒ *page 207*.

If the engine control unit receives faulty vehicle roadspeed signals, the Malfunction Indicator Light (MIL)  will illuminate. If this occurs, contact the nearest authorized Audi dealer for assistance.

### S models

Your vehicle's top speed is electronically limited to 155 mph (250 km/h).

If the engine control unit receives faulty vehicle roadspeed signals, the Malfunction Indicator Lamp (MIL)  will illuminate. If this occurs, contact the nearest authorized Audi dealer for assistance.

### RS models

Your vehicle's top speed is electronically limited to 175 mph (280 km/h).

If the engine control unit receives faulty vehicle roadspeed signals, the Malfunction Indicator Lamp (MIL)  will illuminate. If this occurs, contact the nearest authorized Audi dealer for assistance.

#### **WARNING**

Always observe the posted speed limits and adjust your speed to suit prevailing road, traffic and weather conditions. Never drive your vehicle faster than the maximum speed rating of the tires installed.

## Opening and closing

### Keys

#### Key set



Fig. 25 Key set



Fig. 26 Remote master key: Indicator light

#### **A** Master key with remote control

You can centrally lock and unlock your vehicle and start the engine with the master key with remote control. To fold the key out and back in place, press the release button ⇒ *fig. 25* (arrow).

#### **B** Valet key

The valet key only fits the lock in the driver's door and the ignition lock. If you have to leave the key with somebody else, you are well-advised to turn over the valet key only.

Be aware that the rear lid and glove compartment can be opened from inside the vehicle using the release buttons.

#### **C** Emergency key

The emergency key is only for temporary use if the vehicle key should be lost or misplaced ⇒ .

#### Key replacement

If you lose a key, contact your authorized Audi dealer immediately to have the *lost* key disabled. Be sure to bring all your keys with you.

#### Registered keys

You can check to find out how many keys have been registered to your vehicle. Therefore, when buying a used vehicle, make sure to get all of the keys that belong to it.

Calling up the registered keys ⇒ *page 24*.

#### State of master key battery

When a button is pressed, the check light flashes ⇒ *fig. 26* (arrow). If the check light does not come on or flash, the battery is dead and has to be replaced.

Battery replacement ⇒ *page 33*.

#### **WARNING**

- Do not leave your vehicle unattended with the key in the ignition lock. Entry by unauthorized persons could endanger you or result in theft or damage the vehicle. Always lock all doors and take the key.
- Do not leave children unattended in the vehicle, especially with access to vehicle keys. Unguarded access to the keys provides children the opportunity to start the engine and/or activate vehicle systems such as the power windows etc. Unsupervised operation of any vehicle system by children can result in serious injury.

#### **Tips**

- If you open the driver's door with the key left in the ignition lock, a chime will sound. This is your reminder to remove the key and lock the door.
- For security reasons, replacement keys are only available from Audi dealers.

## Master key with remote control

The remote control allows you to lock or unlock the vehicle electronically.

The transmitter and battery are located in the head of the remote control. The receiver is located inside the vehicle. The maximum effective range depends on several things. Remember, if the battery is weak, the effective range decreases.

If you need to replace the remote control, or if you need to have it repaired, you must see your authorized Audi dealer. Only then can you use the key again.

### **i** Tips

- If the ignition is switched on, the remote control system is deactivated.
- The remote control system can be affected by other systems operating in the same frequency range close to the vehicle, such as mobile telephones, television broadcasting stations, etc.
- For Declaration of Compliance to United States FCC and Industry Canada regulations ⇒ page 246.

## Master key battery replacement

Each master key contains a battery housed under the cover.

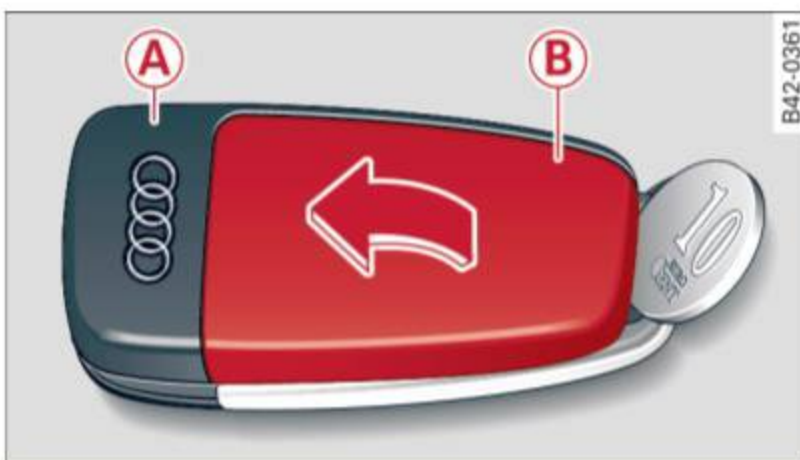

Fig. 27 Master key: opening the cover

- ▶ Pry apart the base ⇒ fig. 27 **A** and the cover **B** **carefully** with a coin.
- ▶ Remove the cover (arrow).
- ▶ Remove the dead battery from the cover.
- ▶ Install the new battery. Please make certain that the “+” sign on the battery faces down

in the cover. Correct polarity is shown on the cover.

- ▶ Place the cover with the new battery on the key base and press both parts together.

### **♻️** For the sake of the environment

Dispose of dead batteries properly so as not to pollute the environment.

### **i** Tips

The replacement battery must be the same specification as the original.

## Electronic immobilizer

The immobilizer helps to prevent unauthorized use of your vehicle.

A computer chip inside your key automatically deactivates the electronic immobilizer when you insert the key in the ignition lock. When you remove the key from the ignition lock, the electronic immobilizer is automatically activated once again.

### **⚠️** WARNING

Always take the key with you when you leave the vehicle. The key can disarm the electronic engine immobilizer and permit an unauthorized person to start the engine and enable operation of the vehicle systems such as power window leading to serious personal injury.

### **i** Tips

- The vehicle cannot be started if an unauthorized key is used. The vehicle may not start if another radio device such as a key for another vehicle or a transponder is located on the key ring.
- For Declaration of Compliance to United States FCC and Industry Canada regulations ⇒ page 246.

## Power locking system

### General description

The power locking system locks or unlocks all doors simultaneously.

The power locking system in your vehicle incorporates the following functions:

- Central locking function
- Remote control feature ⇒ page 33.
- Anti-Theft Alarm System ⇒ page 38.

All the doors and the rear lid are locked by the central locking system when you lock the vehicle.

The unlocking and locking mode\* can be changed in the driver information system ⇒ page 24.

### Unlocking the vehicle

You can unlock the vehicle from outside either by using the remote control **or** by inserting and turning the key in the driver's door lock.

When you **unlock** your vehicle:

- The anti-theft alarm system is deactivated briefly.
- The vehicle interior lights illuminate for approximately 30 seconds.
- All turn signal lights will flash twice when the car is unlocked.
- After unlocking the vehicle, you have 30 seconds to open a door or the rear lid. After 30 seconds, the vehicle automatically locks and the anti-theft alarm system activates again.

The rear lid can be locked or unlocked either by using the remote control **or** by inserting and turning the key in the driver's door lock. Unlocking the vehicle with the remote control  will only *unlock* the rear lid, to *open* it, the lid handle needs to be pressed.

### Locking the vehicle

You can lock the vehicle from outside either by using the remote control **or** by inserting and turning the key in the driver's door lock.

When you **lock** the vehicle:

- All doors and the rear lid are locked.

- All turn signal lights will flash once when the car is locked.
- The anti-theft alarm system is activated. The horn of the anti-theft alarm system will sound and the anti-theft alarm system readiness light, located in the center of the instrument panel below the windshield on the right side of the air vent, will start to blink.
- The vehicle interior lights turn off.

### Automatic locking\*

The automatic locking feature locks all the vehicle doors and the rear lid when you drive faster than 9 mph (15 km/h).

You can unlock the vehicle from the inside by:

- removing the key from the ignition switch (the vehicle will automatically unlock itself) or
- pressing the unlock part of the power lock switch  or

pulling the door handle (to open the door).

If you wish, you can have an authorized Audi dealer convert your power door lock system to automatic locking.

### Unintentionally locking yourself out

The vehicle does not lock with the central locking switch ⇒ page 36 if the driver's door is open.

Do not lock your vehicle with the **remote master key** until all doors and the rear lid are closed. In this way you avoid locking yourself out accidentally.

### WARNING

- When you lock your vehicle from outside, nobody - especially children - should remain inside the vehicle. Remember, when you lock the vehicle from the outside the windows cannot be opened from the inside.
- When you leave the vehicle, always remove the ignition key and take it with you. This will prevent passengers (children, for example) from accidentally being locked in the vehicle should they

accidentally press the power locking switch.

- Do not leave children inside the vehicle unsupervised. In an emergency it would be impossible to open the doors from the outside without the key.

### **i** Tips

- In the event of a crash with airbag deployment all locked doors will be automatically unlocked to give access to the vehicle occupants from the outside.
- If the power locking system should malfunction, you can lock each door individually using the vehicle key.
- If the power locking system should fail, you can still open the fuel tank flap in an emergency ⇒ *page 179*.
- You are well advised not to keep valuables inside an unattended vehicle, visible or not. Even a properly locked vehicle cannot provide the security of a safe!

## Unlocking and locking the vehicle with the remote control

How the remote control works.



Fig. 28 Remote control: function buttons

Whether only the driver's door or the entire vehicle is unlocked when the opening button **A** is pressed once, depends on the settings in the Driver information system **Central locking** menu ⇒ *page 24*.

### To unlock the vehicle

- ▶ Press button **A**.
- ▶ Press button **A** *two times* within two seconds **to unlock all doors and the rear lid**.

### To lock the vehicle

- ▶ Press button **B** ⇒ in *General description on page 34*.
- ▶ Watch that all turn signal lights flash once.

### To unlock rear lid only

- ▶ Press button **C** for approximately one second.

### PANIC Button

- ▶ Push the red button **D** to activate the panic function. The horn sounds and the turn signals flash.
- ▶ Push the button **D** again to deactivate the panic function.

The remote controls allows you to:

- lock or unlock the vehicle
- selectively unlock the rear lid.

The turn signals will flash briefly whenever you lock or unlock the vehicle. Also, the interior light will come on or go off whenever you open or close the driver's door.

The transmitter and battery are located in the head of the remote control. The receiver is located inside the vehicle. The maximum effective range depends on several things. Remember, if the battery is weak, the effective range decreases.

The remote-control key contains a fold-out key that you can use to manually lock or unlock the vehicle and to start the engine.

If you need to replace the remote control, or if you need to have it repaired, you must see your authorized Audi dealer. Only then can you use the key again.

### WARNING

Read and follow all WARNINGS ⇒ in *General description on page 34*.



### **i** Tips

- The remote control key is automatically deactivated when the ignition is switched on.

- The operation of the remote control key can be temporarily disrupted by interference from transmitters in the vicinity of the vehicle working in the same frequency range (e.g. a cell phone, radio equipment).
- In order to make sure the locking function is working, you should always keep your eye on the vehicle to make sure it is properly locked.
- Do not use the remote control if you are inside the car, otherwise you may unintentionally lock the vehicle, and then you would set off the anti-theft alarm when you try to start the engine or open a door. In case this happens anyhow, push the unlock button .
- Use the panic function only if you are in an emergency situation.

### Resetting the remote control

The remote control must be reset if the vehicle does not unlock.

- ▶ Press the unlock button  on the remote control.
- ▶ Manually unlock the driver's door lock with the mechanical key within 30 seconds.
- ▶ Press either the lock-  or the unlock  button to complete the reset sequence.

### Operating locks with the key

To lock and unlock the vehicle from the outside, turn the key in the lock of the driver's door.

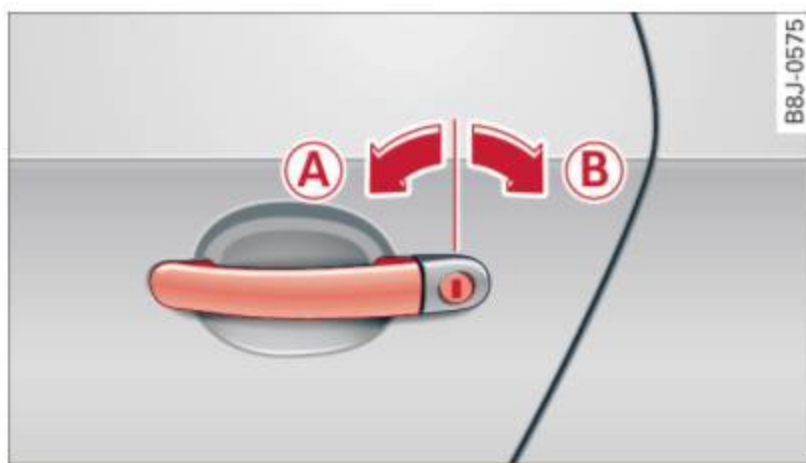



Fig. 29 Key turns for opening and closing.

- ▶ To unlock the vehicle, turn the key to the opening position **(A)** ⇒ fig. 29.
- ▶ To lock the vehicle, turn the key in the lock of the driver's door to the lock position **(B)** ⇒ .

### WARNING



Always read and heed WARNING ⇒  in General description on page 34.

### Locking and unlocking the vehicle from inside

The vehicle can be locked or unlocked from the inside using the power locking switch.



Fig. 30 Section from center console: Central locking switch

- ▶ Press the upper part of the power locking switch  to lock the vehicle ⇒ .
- ▶ Press lower part of the switch  to unlock the vehicle.

If you lock the vehicle using the power locking switch, please note the following:

- You cannot open the doors or the rear lid from the *outside* (increased security, for example when you are stopped at a red light).
- You can unlock and open the doors from the inside by pulling on the door handle.
- If the driver's door is opened (after you have locked the vehicle from the inside using the power locking switch), the door will remain unlocked to prevent you from locking yourself out of your vehicle. After you close the door, you have to lock the driver's door again.
- If you have a crash and the airbag is activated, the doors automatically unlock.

**! WARNING**

- If you use the power locking switch with the doors closed, remember that all the vehicle doors will lock.
- Locked doors make it more difficult for emergency workers to get into the vehicle, which puts lives at risk. Do not leave anyone behind in the vehicle, especially children.

**Emergency locking**

If the power locking system fails (power failure), you will need to lock the passenger door separately.



Fig. 31 Passenger's door: Emergency locking

For this purpose, a mechanical locking device is provided on the end panel of the passenger door (only visible when the door is open).

- ▶ Remove the cap ⇒ *fig. 31*.
- ▶ Insert the key into the inner slot and turn it to the right as far as it can go.

After you close the door you will no longer be able to open it from the outside. You can open it from the inside, however, by pulling on the door latch twice.

**Rear lid/trunk lid****Opening and closing rear lid**

You can open the rear lid from inside the vehicle using a switch in the driver's door.



Fig. 32 Driver's door: remote rear lid release

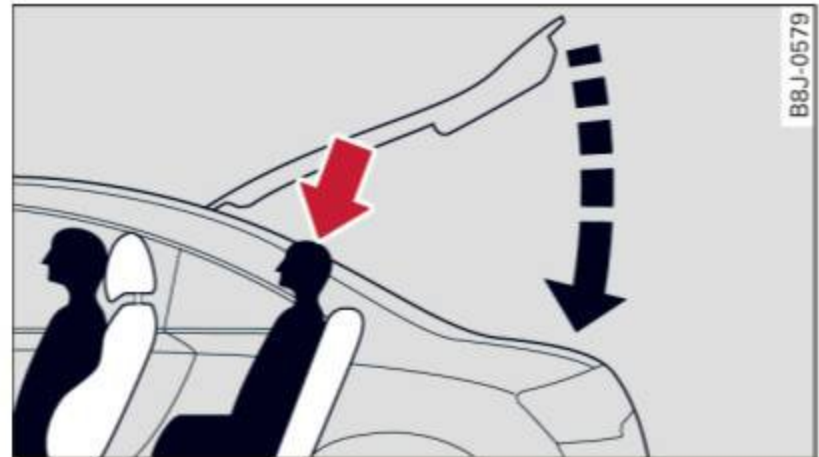





Fig. 33 Opened rear lid

**Opening the rear lid**

- ▶ Press the center button  on the master key or pull the release button  in the driver's door ⇒ *fig. 32*. The rear lid is unlocked.
- ▶ Lift the rear lid.

**Closing the rear lid**

- ▶ Pull the rear lid down and allow it to drop gently ⇒ .

**! WARNING**

- The rear seat area is too small to safely transport passengers taller than 4'11" (1.5 m).
- Persons taller than 4'11" (1.5 m) as well as children in booster seats who are too close to the rear window and roof can suffer severe head and neck injuries when the rear lid is closed or in a crash.

- The minimum clearance between the passengers' heads and the rear window must never - under any circumstances - be less than 1 inch (2.5 cm) when the passengers sit fully upright.
- Always make sure that rear seat passengers cannot be struck when the rear lid is closed.
- After closing the rear lid, always pull up on it to make sure that it is properly closed. Otherwise it could open suddenly when the vehicle is moving.
- To help prevent poisonous exhaust gas from being drawn into the vehicle, always keep the rear lid closed while driving. Never transport objects larger than those which fit completely into the luggage area, because then the rear lid cannot be fully closed.
- Never leave your vehicle unattended especially with the rear lid left open. A child could crawl into the car through the luggage compartment and pull the lid shut, becoming trapped and unable to get out. To reduce the risk of personal injury, never let children play in or around your vehicle. Always keep the rear lid as well as the vehicle doors closed when not in use.

### **i** Tips

- If the rear lid is open or not properly locked when the ignition is turned on, the door and rear lid warning appears in the instrument cluster display.
- If the rear lid on a locked vehicle is unlocked with the middle button  on the remote key, the rear lid is automatically locked again immediately after closing. This is indicated by the turn signals blinking.

### Emergency release for rear lid

If the rear lid cannot be opened, an emergency release is provided.

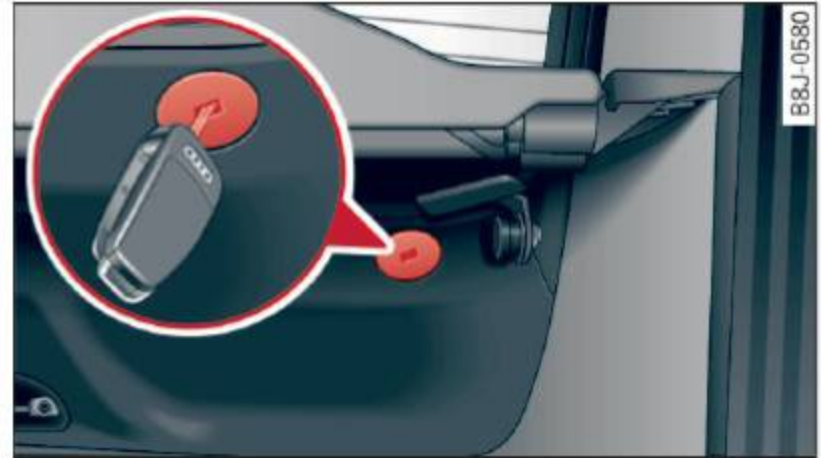

**Fig. 34** Access to emergency release on the left side of the luggage compartment below the rear window



**Fig. 35** Section: Interior luggage compartment: Emergency release

- ▶ Fold down the left rear seatback .
- ▶ Using the vehicle key, pry off the cover  $\Rightarrow$  fig. 34
- ▶ Pull the plastic cord  $\Rightarrow$  fig. 35 in the direction of the arrow.

## Anti-theft alarm system

The anti-theft alarm triggers an alarm if anyone attempts to break into the vehicle.



**Fig. 36** Diode position in the instrument panel

The anti-theft alarm system triggers an audible alarm and turns on the emergency flasher if an unauthorized interference with the vehicle is sensed by the system.

### How is the anti-theft alarm system switched on?

The anti-theft alarm system is switched on when you lock the driver's door manually using the fold-out key, or when you use the remote control. The system is activated approximately 30 seconds after the vehicle is locked. The indicator light ⇒ *fig. 36* starts flashing rapidly for 30 seconds and then blinks slowly.

### How is the anti-theft alarm system switched off?

The anti-theft alarm system is switched off only when you use the remote control to unlock your vehicle. If you do not open a door within 30 seconds after you have unlocked with the remote control, the vehicle will lock itself again automatically.

If you lock just the driver's door using your key, the front passenger's door and the rear lid remain locked.

### When will the anti theft alarm system be triggered?

When the vehicle is locked, the alarm system monitors and protects the following parts of the vehicle:

- engine compartment
- luggage compartment
- doors
- ignition

When the system is activated, the alarm will be triggered if one of the doors, the engine hood or the rear lid are opened, or if the ignition is turned on.

The anti-theft alarm system will also go off when the battery is disconnected.

You can also trigger the alarm by pressing the PANIC button on your remote-control key. This will alert other people in case of emer-

gency. Press the **PANIC** button again to turn off the alarm.

### How is the anti-theft alarm switched off when triggered?

The alarm system is switched off when you unlock the vehicle using the remote-control key or when the ignition is switched on. The alarm will also switch itself off when it comes to the end of its cycle.

### Emergency flasher

The emergency flasher will blink briefly when the doors, engine hood and rear lid are properly closed.

If the emergency flashers do not blink, check the doors, engine hood and rear lid to make sure they are properly closed. If you close a door, the hood or the rear lid with the anti-theft alarm switched on, the emergency flashers will blink only after you have closed the door or lid.

#### Tips

For the anti-theft alarm system to function properly, make sure all vehicle doors and windows are closed before leaving the vehicle.

## Power windows

### Controls

*The driver can operate all windows.*

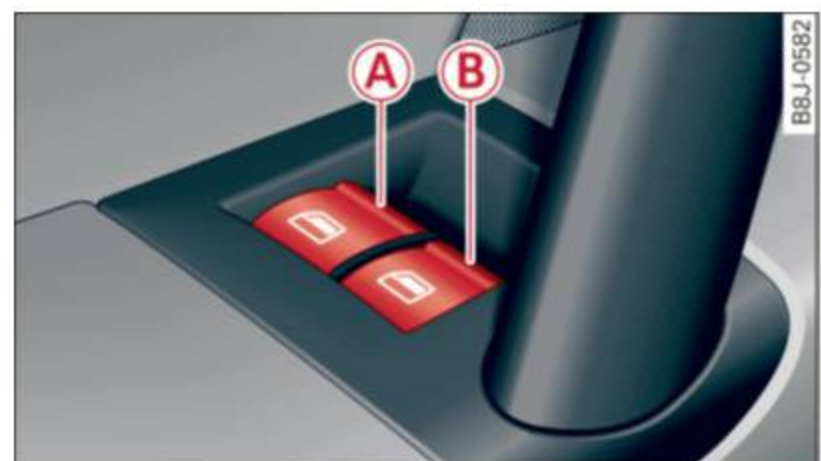

**Fig. 37** Driver's door: power window switches

If the respective switch is pushed or pulled the window will open or close. The power window switches have a **two-position function**: ▶

### Opening the windows

- ▶ Press the switch and **hold it down** until the window has reached the desired position.
- ▶ Press the switch **briefly** to open the window automatically. By briefly pressing the switch again, the downward travel of the window can be stopped in any position ⇒ ⚠.

### Closing the windows

- ▶ Pull the switch and **hold it** until the window has reached the desired position.
- ▶ Pull the switch **briefly** to close the window automatically. By briefly pressing the switch again, the upward travel of the window can be stopped in any position ⇒ ⚠.

Switch **A** ⇒ *fig. 37* operates the window in the driver's door.

Switch **B** operates the window in the front passenger's door.

#### ⚠ WARNING

- Do not leave children unattended in the vehicle, especially with access to vehicle keys. Unsupervised use of the keys can result in starting of the engine and use of vehicle systems such as power windows, etc. which could result in serious injury.
- Remember – you can still open or close the power windows for about ten minutes after the ignition is switched off. Only when either of the front doors are opened are the power windows switched off.
- Be careful when closing the windows. Check to see that no one is in the way, or serious injury could result!
- Always remove the ignition key whenever you leave your vehicle.
- If you lock your vehicle from the outside, no one, especially children, should remain in the vehicle.
- Do not stick anything on the windows or the windshield that may interfere with the driver's field of vision.

#### **i** Tips

- When the doors are opened, the windows are automatically lowered 10 mm.
- The windows can still be opened and closed for about ten minutes after the ignition has been turned off. The power windows are not shut off until one of the front doors is opened.

#### Convenience close/open feature

You can close or open the windows from outside when you lock or unlock your car with the key.

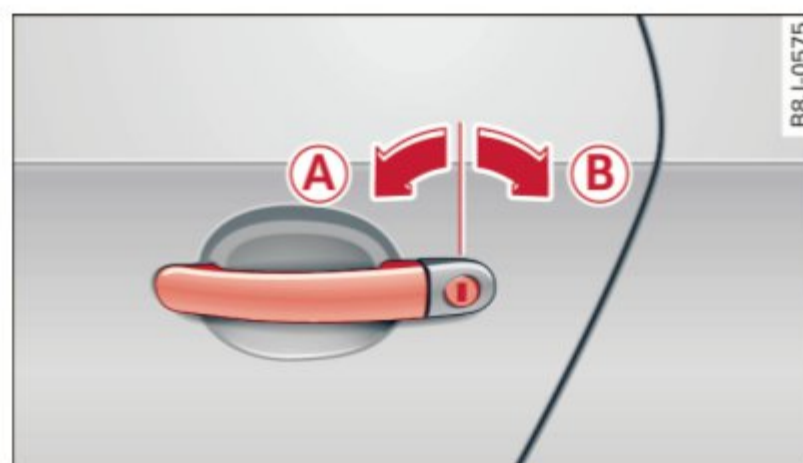

Fig. 38 Key turns for opening and closing

### Closing the windows

- ▶ Insert the key into the lock of the driver's door.
- ▶ Make sure that the windows are not blocked ⇒ ⚠.
- ▶ Turn and hold the key in the lock position **B** ⇒ *fig. 38* until the windows are completely closed.

### Opening the windows

- ▶ Insert the key into the lock of the driver's door.
- ▶ Turn and hold the key in the open position **A**.

The automatic close function will cease if the key is released.

#### ⚠ WARNING

- Be careful when closing the windows. Check to see that no one is in the way, or serious injury could result!

– Always read and heed WARNING ⇨ ⚠ in *General description on page 34.*

### Reactivating the system after battery disconnection

*Reactivating the convenience close/open feature*

If the vehicle battery is disconnected and then reconnected, the automatic closing and opening function will not work until it is reactivated. To reactivate this feature, perform the following steps:

#### Reactivating close/open feature

- ▶ Pull and hold the power window switch until the window is completely closed.
- ▶ Release the switch.
- ▶ Pull the switch again for one second. The automatic closing/opening is now reactivated.

## Clear vision

### Lights

#### Switching the headlights on and off



Fig. 39 Instrument panel: light switch



Fig. 40 Instrument panel: light switch with daytime running lights (DRL)

The light switch must not be overturned past the stops in **either** direction.

#### Switching on automatic headlight control\*

- ▶ Turn the light switch to **AUTO\*** ⇒ *fig. 39*.

#### Switching on the side marker lights

- ▶ Turn the light switch to ☞☞.

#### Switching on the headlights and high beam

- ▶ Turn the light switch to ☞☞.
- ▶ Push the high beam lever forward towards the instrument panel ⇒ *page 44*.

#### Switching off the lights

- ▶ Turn the light switch to **O**.

The headlights only work when the ignition is switched on. While starting the engine or when switching off the ignition, the head-

lights will go off and only the side marker lights will be on.

#### Daytime running lights (DRL) (USA models)

The daytime running lights can be turned on or off using this function. If the function is active, the daytime running lights are turned on automatically when the ignition is switched on.

The daytime running lights are activated **only** when the light switch is at the **AUTO\*** or **DRL\*** position.

#### Daytime running lights (Canada models only)

The daytime running lights are activated **only** when the light switch ⇒ *fig. 39* is either at the **O** or the ☞☞ position.

The daytime running lights function cannot be turned off.

#### Automatic headlight control\*

In the switch position **AUTO** the **automatic headlight control** is turned on. The low beams are turned on automatically through a light sensor as soon as ambient brightness (e.g. when driving into a tunnel) falls below a value preset at the factory. When ambient brightness increases again, the low beams are turned off again automatically ⇒ ⚠.

In the **AUTO** position the low beams are switched off automatically when the ignition is turned off.

#### Light Sensor Malfunction\*

In the event of a light sensor malfunction, the driver is notified in the instrument cluster display:

#### Automatic headlights/automatic wipers defective

For safety reasons the low beams are turned on permanently with the switch in **AUTO\***. However, you can continue to turn the lights on and off using the light switch. Have the

light sensor checked as soon as possible at a dealership.

### Coming home/leaving home function\*

The function is switched on when the switch is in the AUTO\* position and the function is shown as active in the driver information system.

The **coming home** function illuminates the area around the vehicle when the ignition is switched off and the driver's door is opened. The length of time the lights remain on can be set in the menu display (**Illumination** > **Exterior lights** > **coming home**).

The **leaving home** function illuminates the area around the vehicle when unlocking it.

### WARNING

- Never use daytime running lights to see where you are going. They are not bright enough and will not let you see far enough ahead for safety, especially at dusk or when it is dark. Always switch on the low beams at dusk or when it is dark.
- Automatic headlights are only intended to assist the driver. They do not relieve the driver of his responsibility to check the headlights and to turn them on manually according to the current light and visibility conditions. For example, fog and rain cannot be detected by the light sensors. So always switch on the headlights under these weather conditions and when driving in the dark .
- Crashes can happen when you cannot see the road ahead and when you cannot be seen by other motorists.
  - Always turn on the headlights so that you can see ahead and so that others can see your car from the back.
- Please observe legal regulations when using the lighting systems described.

### Tips

- The light sensor for headlight control is located in the rear view mirror mount. Do not apply any stickers to the wind-

shield in this area to prevent malfunctions or failures.

- Some exterior lighting functions can be adjusted in the driver information system ⇒ *page 24*.
- If you remove the ignition from the ignition lock while the headlights are still on, a buzzer will sound as long as the driver's door is open to remind you to turn off the lights.
- Always observe the specific local regulations for your area as to when to use your lights.
- With automatic headlights, the high-beam function is also available, but with one restriction: If you have not switched the high beams back to low beams during automatic headlight operation (for example, after driving through a tunnel), only the low beams come on the next time automatic headlights are switched on. To use the high beams, you first have to pull the high beam lever back and then push the lever forward again.
- In cool or damp weather, the inside of the headlights, turn signals and tail lights can fog over due to the temperature difference between the inside and outside. They will clear shortly after switching them on. This does not affect the service life of the lighting.

### Adaptive light

Applies to vehicles: with Adaptive Light

*When driving around bends, the relevant area of the road is better illuminated.*

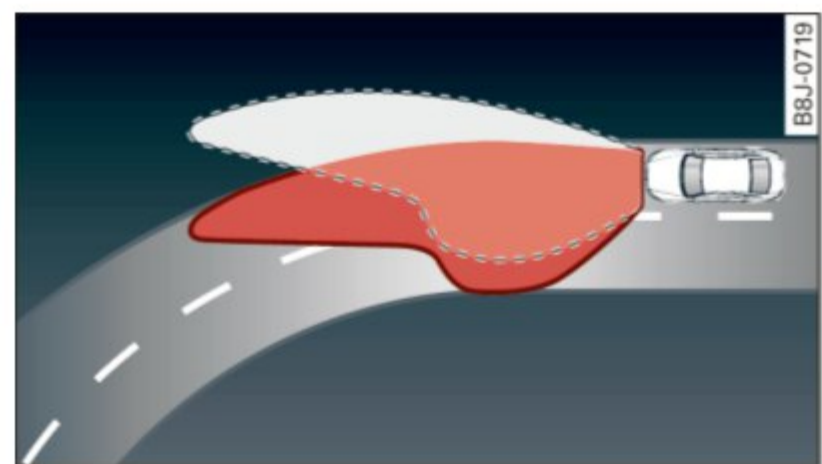

Fig. 41 Adaptive light when driving

The benefit of adaptive light is that the curve and the edge of the road are better illuminated ⇒ *fig. 41*. The adaptive light is controlled automatically, depending on vehicle speed and steering wheel angle.

When driving around bends, the headlights are controlled according to steering wheel angle. So that there is no black area ahead of the vehicle, the two main beams pivot at different angles.

**i Tips**  
The system works above a speed of about 6 mph (10 km/h).

**Front fog lights**

Use the light switch to turn on the front fog lights.



Fig. 42 Fog light activation: light switch position on vehicles WITHOUT sensor light

**Switching on the front fog lights**

- ▶ Do **not** turn the light switch toward the fog light symbol.
- ▶ Turn the light switch to the high beam or to the low beam.
- ▶ Pull the light switch to the **first stop**.

When the front fog lights are on, the symbol next to the light switch will illuminate.

**i Tips**  
With the switch in **AUTO** front fog lights cannot be turned on in addition.

**Turn signals and high beam lever**

The lever on the left side of the steering column is used to operate the turn signals and the high beam as well as the headlight flasher.



Fig. 43 Turn signal and high beam lever

The turn signal and high beam lever has the following functions:

**Turn signals**

- ▶ Push the lever up as far as it can go to turn on the right turn signal or down to turn on the left turn signal.
- ▶ Move the lever briefly until you meet resistance and release it to flash three times.
- ▶ Move the lever (up or down) until you meet resistance and hold it there to determine the flashing time for the turn signals.

**High beam**

- ▶ Push the lever forward to switch on the high beam.
- ▶ Pull the lever back towards you to switch off the high beam.

**Headlight flasher**

- ▶ Pull the lever toward the steering wheel to use the headlight flasher.

**Notes on these features**

- The *turn signals* only work with the ignition switched on. The indicator lights in the instrument cluster also blink.
- After you have turned a corner, the turn signal switches off automatically.
- The *high beam* works only when the headlights are on. The indicator light in the

instrument cluster illuminates when the high beams are on.

- The *headlight flasher* works only as long as you hold the lever - even if there are no lights turned on. The indicator light  in the instrument cluster illuminates when you use the headlight flasher.

### WARNING

Do not use the high beam or headlight flasher if you know that these could blind oncoming traffic.



### Emergency flasher

The *emergency flasher* makes other motorists aware that you or your vehicle are in an emergency situation.



Fig. 44 Center console: emergency flasher switch

- ▶ Press the switch  ⇒ *fig. 44*, to switch the emergency flasher on or off.

When the emergency flasher is on, all four turn signals blink at the same time. The turn signal indicator lights   in the instrument cluster, as well as the light in the emergency flasher switch  blink likewise. The emergency flashers also work when the ignition is turned off.

The emergency flasher will automatically switch on if you are in an accident where the airbag has deployed.

### Tips

You should switch on the emergency flasher when:

- you are the last vehicle standing in a traffic jam so that any other vehicles coming can see you, or when
- your vehicle has broken down or you are in an emergency situation, or when
- your vehicle is being towed by a tow truck or if you are towing another vehicle behind you.

## Interior lights

### Interior lights

The *interior lights* include the reading lights for the driver and the front passenger.

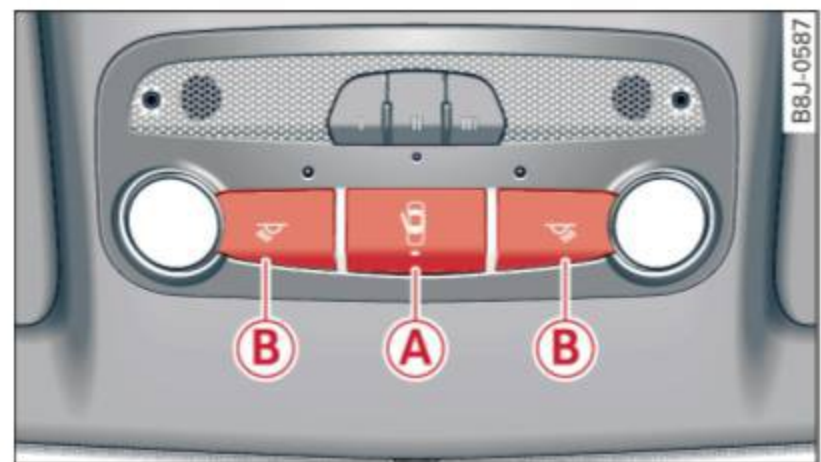



Fig. 45 Section from headliner: Interior lights

### Activating door contact circuit

- ▶ Press the button . The LED in the button illuminates.

### Deactivating door contact circuit

- ▶ Press the button . The LED in the button goes out.

### Front reading lights

- ▶ Press one of the switches  to turn the right or left reading light on or off.

With the door contact circuit, the interior lights turn on as soon as you unlock the vehicle or open the doors. The interior lights are also turned on when the ignition key is removed. The lights turn off about 30 seconds after the doors are closed. When the vehicle is locked or when the ignition is turned on, the interior lights are turned off.

When a door is open, the interior lights are turned off after about 10 minutes to prevent battery draining.

The brightness of the lights is controlled automatically by a dimmer when they are switched on and off.

**Instrument panel illumination**

The illumination of the instruments, displays and the center console can be adjusted.



Fig. 46 Instrument panel illumination

You regulate the brightness of the instruments with the left thumbwheel ⇒ fig. 46.

**Ignition ON, light switch at** .

With the ignition switched ON, the glow of instrument needles can be adjusted to appear brighter or dimmer.

**Ignition ON, light switch at or** .

With the lights switched on, the brightness of instrument cluster (i.e. needles, gauges and displays) and center console illumination can be adjusted.

**! Note**

The instrument cluster and center console illumination (gauges and needles) comes on when you switch on the ignition and the **vehicle headlights are off**. Be aware of the following difference between models built to US or Canadian specifications:

- USA models: illumination of the instrument cluster (gauges and needles), dash and center console around the gearshift lever is controlled by a light sensor located in the instrument panel. The instrument panel illumination will automatically become dimmer as the daylight fades away and eventually will go out completely when outside light is very

low. This is to remind you, the driver, to switch on the headlights before it gets too dark.

- Canada models: instrument panel illumination will stay bright regardless of the intensity of ambient light. Always be aware of changes in outside light conditions while you are driving. Respond in time to fading daylight by turning the light switch to position (or “AUTO” if your car is equipped with this feature) to turn on your headlights.

**Luggage compartment light**

The light is located on the right side of the luggage compartment.

These lights come on automatically when the rear lid is opened. The lights turn off automatically if the lid is left open for more than 10 minutes.

**Vision**

**Sun visors**

Using the sun visors makes driving safer.



Fig. 47 Sun visor

The driver's and passenger's sun visors can be pulled from the brackets above the center of the windshield and swung toward the doors ⇒ fig. 47.

The vanity mirrors in the sun visors are equipped with lids. When the lid is opened , the mirror light in the headliner turns on automatically. It turns off when the lid is closed and the visor is folded up again.

## Mirrors

### Adjusting the exterior mirrors



Fig. 48 Forward section of driver's armrest: power mirror controls

Turn the knob to the desired position:

 - In this position, you can adjust the driver's and front passenger's exterior mirrors by turning the knob in the desired direction.

 - The mirrors are heated depending on the outside temperature.

 - The exterior mirrors fold in\*

You are well-advised to fold the exterior mirrors in when maneuvering in tight spaces or when leaving the car parked close to other vehicles.

### WARNING

- Curved (i. e. convex) mirror surfaces increase your field of view. Remember that vehicles or other objects will appear smaller and farther away than when seen in a flat mirror. If you use this mirror to estimate distances of following vehicles when changing lanes, you could estimate incorrectly and cause an accident.

### Note

- If the mirror housing is moved unintentionally (for example, while parking your vehicle), then you must first fold the mirror electrically. Do not readjust the mirror housing manually. You could damage the motor which controls the mirror.
- If you wash the vehicle in an automatic car wash, you must fold the exterior mir-

rors in to reduce the risk of damage to the mirrors. Never fold power folding exterior mirrors\* by hand. Only fold them in and out using the power controls.

### Tips

If there should be a malfunction in the electrical system, you can still adjust the exterior mirrors by pressing the edge of the mirror.

### Dimming the mirrors

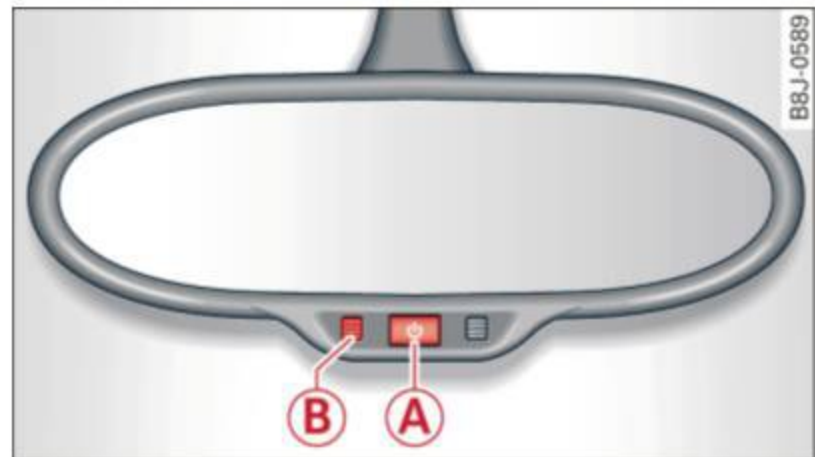

Fig. 49 Automatic dimming rearview mirror\*

### Manual anti-glare adjustment

- ▶ Move the small lever (located on the bottom edge of the mirror) to the rear.

### Automatically dimming mirrors\*

- ▶ To dim the rearview mirror and both exterior mirrors, press the **A** button. The diode **B** turns on. The rearview and exterior mirrors dim automatically when light shines on them, for example from headlights on a vehicle to the rear.

### WARNING

Electrolyte fluid can leak from automatic dimming mirrors if the glass is broken. Electrolyte fluid can irritate skin, eyes and respiratory system.

- Repeated or prolonged exposure to electrolyte can cause irritation to the respiratory system, especially among people with asthma or other respiratory conditions. Get fresh air immediately by leaving the vehicle or, if that is not possible, open windows and doors all the way.

- If electrolyte gets into the eyes, flush them thoroughly with large amounts of clean water for at least 15 minutes; medical attention is recommended.
- If electrolyte contacts skin, flush affected area with clean water for at least 15 minutes and then wash affected area with soap and water; medical attention is recommended. Thoroughly wash affected clothing and shoes before reuse.
- If swallowed and person is conscious, rinse mouth with water for at least 15 minutes. Do not induce vomiting unless instructed to do so by medical professional. Get medical attention immediately.

### ! Note

Liquid electrolyte leaking from broken mirror glass will damage any plastic surfaces it comes in contact with. Clean up spilled electrolyte immediately with clean water and a sponge.

### i Tips

- Switching off the dimming function of the inside rear view mirror also deactivates the automatic dimming function of the exterior mirrors.
- The automatic dimming mirrors do not dim when the interior lighting is turned on or the reverse gear is selected.
- Automatic dimming for the mirror only operates properly if the light striking the inside mirror is not hindered in any way.

## Wiper and washer system

### Windshield wiper

The windshield wiper lever controls both the windshield wipers and the washer system.



Fig. 50 Wiper lever: windshield wiper lever positions

The windshield wiper lever ⇒ *fig. 50* has the following positions:

### Intermittent wiping (activating rain sensor)\*

- ▶ Move the lever up to position ①.
- ▶ Move the interval set switch **A**, to change the intervals.

### Low wiper speed

- ▶ Move the lever up to position ②.

### High wiper speed

- ▶ Move the lever up to position ③.

### One-touch wiping

- ▶ Move the lever to position ④, when you want to wipe the windshield *briefly*.

### Automatic wiper/washer

- ▶ Pull the lever to position ⑤ (toward the steering wheel) and hold.
- ▶ Release the lever. The washer stops and the wipers keep going for about four seconds.

### Turning off the wipers

- ▶ Move the lever back to position ①.

The windshield wipers and washer only work when the ignition is turned on. If you switch off the ignition with the windshield wiper lever still in the interval wipe position and then ▶

come back a while later and drive off, the rain sensor will reactivate itself after the vehicle speed has exceeded 4 mph (6 km/h).

The rain sensor\* is only activated with the wiper lever set to position ①. When it starts to rain, the rain sensor will automatically activate the intermittent wiping mode.

To reduce the sensitivity of the sensor, move switch Ⓐ down. To increase the sensitivity, move the switch up. The higher you adjust the sensitivity, the faster the sensor will react when it senses moisture on the windshield. The pauses between wiper turns depend not only on the sensitivity setting, but on the vehicle speed as well.

During brief stops, e.g. at a red light, wiper motion will automatically be reduced to the next lower speed. Wipers already turning at low speed change to intermittent wiping.

When the ignition is turned on, the washer jets are heated.

### WARNING

- Wiper blades are crucial for safe driving! Only when they are in good condition are they able to clear the windows properly to provide uncompromising visibility. Worn or damaged wiper blades are a safety hazard ⇒ *page 51, Replacing windshield wiper blades!*
- The light/rain sensor\* is only designed to assist and support the driver. It remains entirely the driver's responsibility to monitor outside weather conditions and to manually activate the wipers as soon as rain or drizzle reduces visibility through the windshield.
- The windshield must not be treated with water-repellent materials. They can increase glare under poor visibility conditions such as wetness, darkness, or when the sun is low on the horizon. In addition, they can cause the windshield wipers to chatter.

### Note

In freezing or near freezing conditions:

- Always check that the wiper blades are not frozen to the glass before you turn the wipers on. Loosen a wiper blade which is frozen in place before operating the wipers to prevent damage to the wiper blade or the wiper motor.
- Do not use the wipers to clear a frosted window. Using the wipers as a convenient ice scraper will destroy the wiper blades.
- Before you take your vehicle to an automatic car wash, make sure you have the windshield wiper system switched off (lever in position 0), otherwise the windshield wiper system could get damaged in the car wash if it should suddenly come on.

### Tips

- The windshield wipers are switched off when the ignition is turned off. Activate the windshield wipers after the ignition is switched back on by moving the windshield wiper lever to any position.
- Worn or dirty windshield wiper blades cause smearing, which can affect the operation of the light/rain sensor\*. Check the condition of your windshield wiper blades regularly.
- The rain sensor is part of the interval wiping system. Turning off the ignition will also deactivate the rain sensor. To reactivate the sensor, switch off the interval wiping function, then switch it back on again.
- Applies to vehicles with light/rain sensor: When the wipers are switched on manually and in rain conditions, the automatic headlights\* turn on ⇒ *page 42, Switching the headlights on and off* or off during the day when the wipers are no longer operating. The automatic headlights\* function is available in this case only when the light switch is in the "AUTO" position ⇒ *page 42, fig. 39.*

- Make sure the washer fluid reservoir in the engine compartment is topped off before going on a long trip. Look up ⇒ *page 194* for checking and filling the washer container.
- The wipers only operate with the hood completely closed.

### Headlight washer system

Applies to vehicles: with headlight washer system

*The headlight washer system cleans the headlights.*

- ▶ Operate the windshield wiper/washer system ⇒ *page 48, fig. 50* (5) with the headlights turned on by holding the lever for longer than one second.

The washer jets extend forward out of the front bumper driven by water pressure to spray the front headlights with water.

You should inspect the headlights regularly (for example when refueling) and clean off any solid dirt or insects from the lenses.

To ensure the system works properly in winter, keep the washer jets free of snow and remove any ice using a de-icing spray.

### Service position

*It is only possible to change wiper blades if you move the wiper arms to the service position.*

In order to use the windshield wipers, the front lid must be completely closed.

### Moving wiper blades to the service position

- ▶ When there is a risk of frost, make sure that the wiper blades are not frozen to the windshield.
- ▶ Switch the ignition on.
- ▶ Move the wiper lever to position **0** ⇒ *page 48, fig. 50*.
- ▶ Press the **Reset** button until the **Display type** menu appears in the Driver Information System display.

- ▶ Using the rocker switch and the **Reset** button, select the **Set > Wipers > Front > Service position on** function. The windshield wiper arms move to the service position.

### Moving wiper blades to park position

- ▶ Make certain that the wiper arms are lying against the windshield.
- ▶ Switch the ignition on and move the wiper lever from position **0** to **4** ⇒ *page 48, fig. 50*. The wiper arms will move back to the park position.

### ! Note

Never drive your vehicle when the windshield wiper arms are in the service position and pulled away from the windshield. When you drive faster than 4 mph (6 km/h), the wiper arms automatically return to the park position and could cause paint damage to the front lid!

### i Tips

- You can also turn on the service position, for example, if you want to protect the windshield from icing by using a cover.
- The service position moves to **off** automatically when you operate the windshield wiper lever, or speed exceeds 4 mph (6 km/h).

## Replacing windshield wiper blades

Wiper blades in good condition help keep the windshield clear.

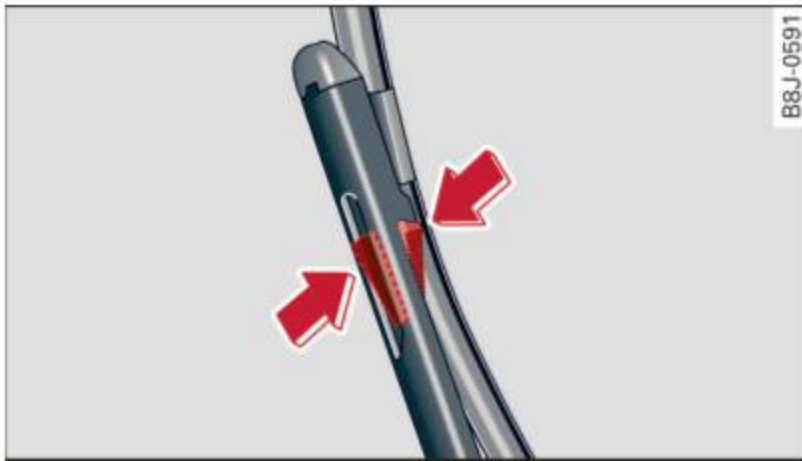

Fig. 51 Unlatching wiper blades

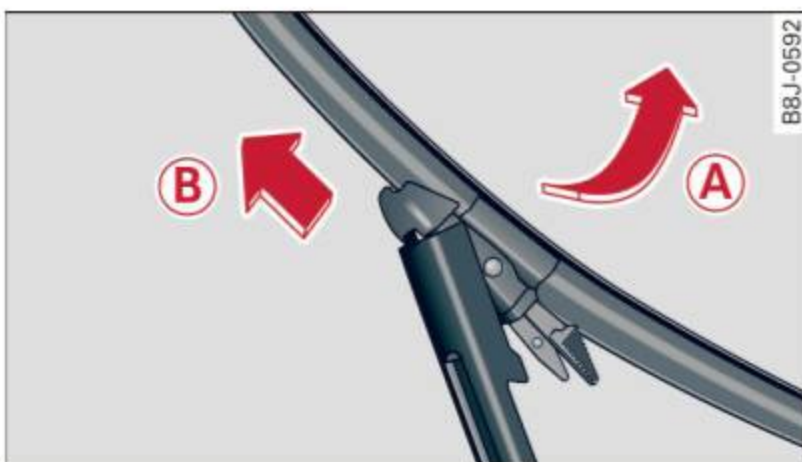

Fig. 52 Removing wiper blades

### Removing the wiper blade

- ▶ Move the wipers to the service position ⇒ *page 50*.
- ▶ Fold the windshield wiper arm away from the glass.
- ▶ On the upper end of the wiper arm at the corrugation, squeeze the plastic retainer together on both sides in the direction of the arrow ⇒ *fig. 51*.
- ▶ Rotate the wiper blade in the direction of the arrow (A) ⇒ *fig. 52* away from the wiper arm.
- ▶ Lift the wiper blade off in the direction of the arrow (B).

### Installing the wiper blade

- ▶ Place the rounded end of the wiper onto the end of the wiper arm in the **opposite** direction to the arrow (B) ⇒ *fig. 52*.
- ▶ Swing the wiper in the **opposite** direction to the arrow (A) onto the wiper arm.
- ▶ Squeeze the corrugation on the wiper until you hear it click in the wiper arm.

- ▶ Fold the wiper arm back onto the windshield.
- ▶ Move the wipers to the park position ⇒ *page 50*.

The front wiper blades measure left side 23.20 in. (590 mm) and right side 18.50 in. (470 mm) in length.

Clean your wiper blades regularly with a windshield washer solution to prevent streaking. If the blades are very dirty, for example with insects, carefully clean the blades with a sponge or a soft brush.

If the wiper blades begin to streak the windshield, this could be caused by residue left on the windshield by automatic car washes.

Fill the windshield washer container with a special solution available at your authorized Audi dealer to remove the residue.

Be sure to inspect the condition of your wiper blades regularly. For safety reasons, replace your wiper blades once or twice a year if necessary. See your authorized Audi dealer for replacement blades.

### ! WARNING

- Clean your wiper blades regularly with a windshield washer solution to prevent streaking. If the wiper blades are very dirty, for example with insects, carefully clean the wiper blades with a sponge or a soft brush.
- For your safety, you should replace the wiper blades once or twice a year. See your authorized Audi dealer for replacement blades.

### ! Note

- The windshield wiper blades must only be replaced when in the service position ⇒ *page 50*! Otherwise, you risk damaging the paint on the hood or the windshield wiper motor.

- To help prevent damage to the wiper system, always loosen blades which are frozen to the windshield before operating wipers.
- To help prevent damage to wiper blades, do not use gasoline, kerosene, paint thinner, or other solvents on or near the wiper blades.
- To help prevent damage to the wiper arms or other components, do not attempt to move the wipers by hand.

**i Tips**

- Commercial hot waxes applied by automatic car washes affect the cleanability of the glass surface.
- The front wiper blades are different lengths; the blade on the driver's side is longer.

## Digital compass

### Activating or deactivating the compass

Applies to vehicles: with digital compass

The direction is displayed on the interior rear view mirror.

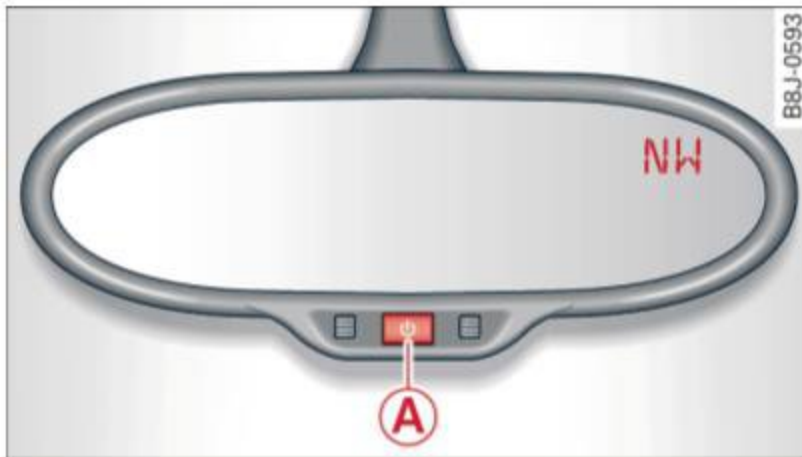

Fig. 53 Inside rear view mirror: digital compass activated

- ▶ To activate or deactivate, hold the **A** ⇒ fig. 53 button down until the red display appears or disappears.

The digital compass only works with the ignition turned on. The directions are displayed as initials: **N** (North), **NE** (Northeast), **E** (East), **SE** (Southeast), **S** (South), **SW** (Southwest), **W** (West), **NW** (Northwest).

**i Tips**

To avoid inaccurate directions, do not allow any remote controls, electrical systems, or metal parts close to the mirror.

### Setting the magnetic deflection zone

Applies to vehicles: with digital compass

The correct magnetic deflection zone must be set in order to display the directions correctly.

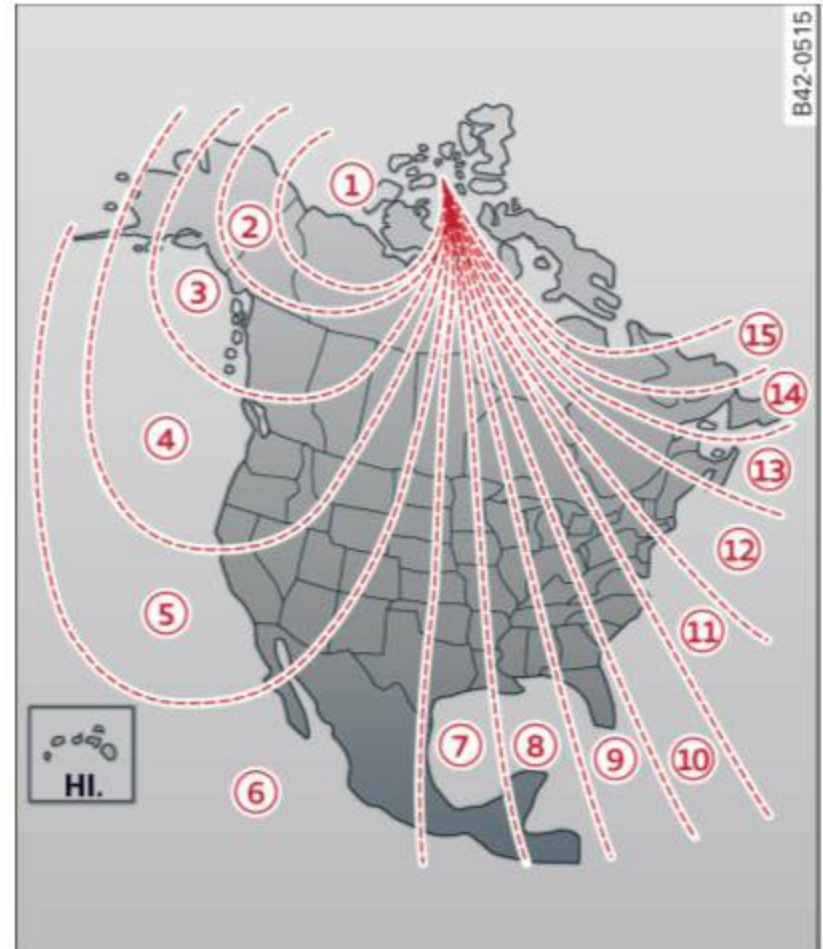

Fig. 54 North America: magnetic deflection zone boundaries

- ▶ Hold the **A** ⇒ page 52, fig. 53 button down until the number of the set magnetic deflection zone appears on the interior rear view mirror.
- ▶ Adjust the magnetic deflection zone by repeatedly pressing on the **A** button. The set mode automatically deactivates after a few seconds.

### Calibrating the compass

Applies to vehicles: with digital compass

The compass has to be recalibrated if the display is wrong or inaccurate.

- ▶ Hold the **A** button down until the letter **C** is displayed on the interior rear view mirror. ▶

- ▶ Drive in a circle at a speed of about 5 mph (10 km/h) until a direction is shown on the interior rear view mirror.

**WARNING**

The digital compass is to be used as a directional aid only. Even though you may want to look at it while you are driving, you must still pay attention to traffic, road and weather conditions as well as other possible hazards.

## Seats and storage

### General recommendations

#### Why is your seat adjustment so important?

*The safety belts and the airbag system can only provide maximum protection if the front seats are correctly adjusted.*

There are various ways of adjusting the front seats to provide safe and comfortable support for the driver and the front passenger. Adjust your seat properly so that:

- you can easily and quickly reach all the switches and controls in the instrument panel
- your body is properly supported thus reducing physical stress and fatigue
- the safety belts and airbag system can offer maximum protection ⇒ *page 108*.

In the following sections, you will see exactly how you can best adjust your seats.

There are special regulations and instructions for installing a child safety seat on the front passenger's seat. Always heed the information regarding child safety provided in ⇒ *page 130, Child Safety*.

#### WARNING

Incorrect seating position of the driver and all other passengers can result in serious personal injury.

- Always keep your feet on the floor when the vehicle is in motion – never put your feet on top of the instrument panel, out of the window or on top of the seat cushion! This applies especially to the passengers. If your seating position is incorrect you increase the risk of injury in the case of sudden braking or an accident. If the airbag inflates and the seating position is incorrect this could result in personal injury or even death.
- It is important for both the driver and front passenger to keep a distance of at

least 10 inches (25 cm) between themselves and the steering wheel and/or instrument panel. If you're sitting any closer than this, the airbag system cannot protect you properly. In addition to this, the front seats and head restraints must be adjusted to your body height so that they can give you maximum protection.

- Always try to keep as much distance as possible between yourself and the steering wheel or instrument panel.
- Do not adjust the driver's or front passenger's seat while the vehicle is moving. Your seat may move unexpectedly, causing sudden loss of vehicle control and personal injury. If you adjust your seat while the vehicle is moving, you are out of position.

#### Driver's seat

*The correct seat position is important for safe and relaxed driving.*

We recommend that you adjust the driver's seat in the following manner:

- ▶ Adjust the seat in fore and aft direction so that you can easily push the pedals to the floor while keeping your knee slightly bent ⇒  in *Why is your seat adjustment so important? on page 54*.
- ▶ Adjust the seatback so that when you sit with your back against the seatback, you can still grasp the top of the steering wheel.
- ▶ Position the head restraint according to the occupant's height ⇒ *page 57*. For maximum protection, the top of the head restraint should be at least at eye level, preferably higher and ideally level with the top of the head ⇒ *page 94, fig. 92*.

#### WARNING

Never place any objects in the driver's footwell. An object could get into the pedal area and interfere with pedal function. In case of sudden braking or an accident, you would not be able to brake or accelerate!

## Front passenger's seat

Always move the front passenger seat into the rearmost position.

To avoid contact with the airbag while it is deploying, do not sit any closer to the instrument panel than necessary and always wear the three-point safety belt provided adjusted correctly. We recommend that you adjust the passenger's seat in the following manner:

- ▶ Bring the backrest up to an (almost) upright position. **Do not** ride with the seat reclined.
- ▶ The ideal position for the head restraint is with the upper edge of the restraint level with the top of your head ⇒ *page 57*. You should *not* lower the top of the restraint below the level of your eyes.
- ▶ Place your feet on the floor in front of the passenger's seat.

## Adjusting front seats manually

### Adjustment controls

Applies to vehicles: with manual seat adjustment

Various controls on the manual seats provide a wide range for individual adjustments.

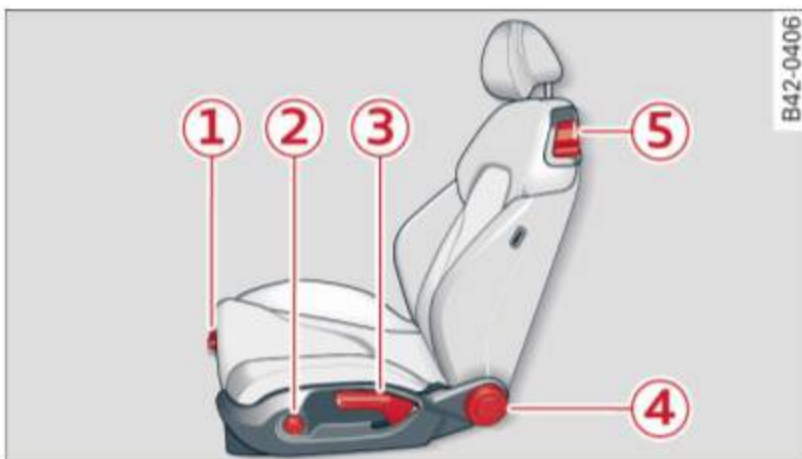

Fig. 55 Adjustment controls: locations on driver's seat

- ① Moving the seat forward or backward
- ② Adjusting the lumbar support
- ③ Adjusting the seat height
- ④ Adjusting the seatback angle
- ⑤ Releasing the seatback

### **i** Tips

Some of the controls are fitted on certain models only or they are optional equipment.

### Adjusting the manual seats

Applies to vehicles: with manual seat adjustment

*Position, angle and shape of the manual seats can be adjusted to provide safe and comfortable seating.*

Read and heed all **WARNINGS** ⇒ before you adjust your seat.

### Moving the front seats forward or backward

- ▶ Lift the lever ① ⇒ *page 55, fig. 55* and slide the seat to the desired position.
- ▶ Release the lever and then move the seat further until you feel and hear it engage.

### Adjusting the seat height

- ▶ Pull the lever ③ up and pump it to raise the seat.
- ▶ Push the lever down and pump it to lower the seat.

### Adjusting the seatback angle

- ▶ Lean forward to take your weight off the seatback.
- ▶ Turn the hand wheel ④ in the direction you want the seatback to tilt.

### Releasing seatback

- ▶ Pull the lever ⑤ up.
- ▶ Push the seatback forward.

### WARNING

- Never adjust the driver's or front passenger's seat while the vehicle is moving. If you do this while the vehicle is moving, you will be out of position. Always adjust the driver's or front passenger's seat when the vehicle is not moving.
- Be careful when adjusting the seat height. Check to see that no one is in the way, or serious injury could result!

– To reduce the risk of injury in the case of sudden braking or accident, front passengers must never ride in a moving vehicle with the seatback reclined. Safety belts and the airbag system only offer maximum protection when the seatback is upright and the safety belts are properly positioned on the body. The more the seatback is reclined, the greater the risk of personal injury from an incorrect seating position and improperly positioned safety belts!

## Power seats

### Adjustment switches

Applies to vehicles: with power seats

*The operating logic for the switches corresponds to the construction and function of the seat.*

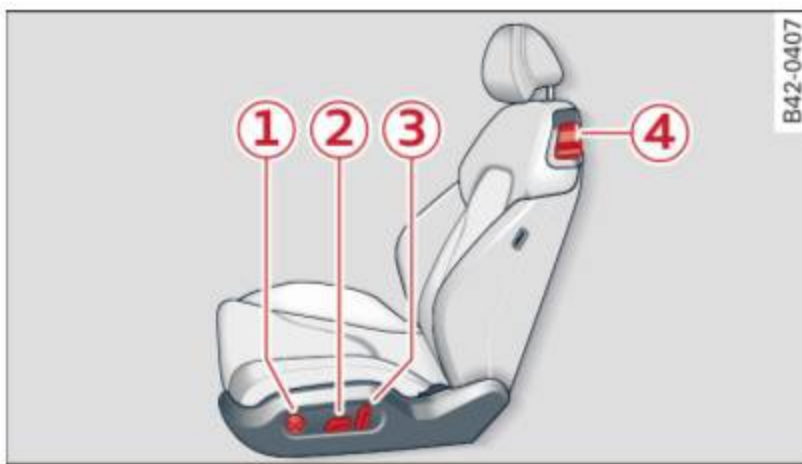

Fig. 56 Adjustment switches: locations on driver seat

The operating logic for the switches corresponds to the construction, the design and the function of the seat. Push or pull either switch in exactly the same direction you want the corresponding part of the seat to move.

### Adjustment switches

- ① Adjusting the lumbar support
- ② Adjusting seat height and fore-and-aft position
- ③ Adjusting the angle of the seatback
- ④ Releasing the seatback

### Power seat adjustment

Applies to vehicles: with power seats

*The switches can be moved in various directions to allow precise adjustment.*

Read and heed all warnings before you adjust your seat. ⇒ ⚠.

#### Adjusting the curvature of the lumbar support

- ▶ Push the forward or rear depression on the switch shell ① ⇒ page 56, fig. 56 to increase or decrease the backrest curvature.

#### Adjusting the height of the lumbar support

- ▶ Push the top or bottom depression on the switch shell ① to raise or lower the support in the backrest.

#### Moving the front seats forward or backward

- ▶ Press the switch ② forward or backward horizontally.

#### Adjusting the seat height

- ▶ Pull or push the switch ② evenly at both ends to raise or lower the seat.

#### Angling the seat cushion up and down (front)

- ▶ Pull or push the switch ② at the front only to raise or lower the seat.

#### Angling the seat cushion up and down (rear)

- ▶ Pull or push the switch ② at the rear only to raise or lower the seat.

#### Adjusting the seatback

- ▶ Push or pull the switch ③ in the same direction you want the seatback to tilt.

#### Releasing seatback

- ▶ Pull the lever ④ up.
- ▶ Push the seatback forward. ▶

### WARNING

- Never adjust the driver's or front passenger seat while the vehicle is moving. If you do this while the vehicle is moving, you will be out of position. Always adjust the driver's or front passenger seat when the vehicle is not moving.
- Be careful when adjusting the seat height. Check to see that no one is in the way, or serious injury could result!
- Because the seats can be electrically adjusted with the ignition key removed, never leave children unattended in the vehicle. Unsupervised use of the electric seat adjustments may cause serious injury.
- To reduce the risk of injury in the case of sudden braking or accident, front passengers must never ride in a moving vehicle with the seatback reclined. Safety belts and the airbag system offer maximum protection only when the seatback is upright and the safety belts are properly positioned on the body. The more the seatback is reclined, the greater the risk of personal injury from an incorrect seating position and improperly positioned safety belts!
- Always make sure the front seatbacks are in the upright position and securely locked in place when driving.

## Head restraints

### Adjusting head restraints, front seats

The head restraints must be adjusted properly to provide protection.

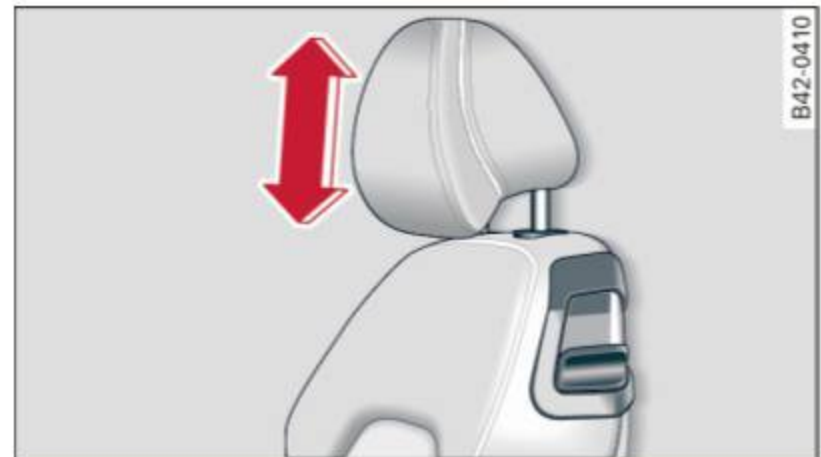

**Fig. 57** Driver's seat head restraint: adjusting the height

The head restraints on the *front* seats can be adjusted to provide safe support to head and neck at the optimum height. When optimally adjusted, the top of the restraint should be level with the top of the head ⇒ *page 94, Proper adjustment of head restraints.*

- ▶ Grasp the sides of the head restraint with both hands and slide it upward/downward until you feel it click into place ⇒ *fig. 57.*

### WARNING

- Driving without head restraints or with head restraints that are not properly adjusted increases the risk of serious or fatal neck injury dramatically.
- Read and heed all WARNINGS ⇒ *page 94.*

### Tips

Correctly adjusted head restraints and safety belts are an extremely effective combination of safety features.

## Rear seats

### General information

Safe transportation of passengers on the rear seats requires proper safety precautions.



Fig. 58 Correct seat position on the rear bench seat

All passengers on the rear seats must be seated in compliance with the safety guidelines explained in ⇒ page 100 and ⇒ page 108.

The correct seating position is critical for the safety of front *and* rear seat passengers alike ⇒ page 93.

### WARNING

- Occupants in the front *and* rear seats must always be properly restrained.
- Persons taller than 4 feet 11 inches (1.50 m) must never sit in the rear seat area. The rear passenger compartment is too small for passenger taller than 4 feet 11 inches (1.50 m).
- The minimum clearance between the passengers' heads and the rear window must never, under any circumstances, be less than 1 inch (2.5 cm) with the passengers sitting fully upright. Taller persons, as well as children on booster seats who are too close to the rear window, can suffer severe head and neck injuries when the rear lid is closed or if a crash occurs. Always make sure that rear seat passengers cannot be struck when the rear lid is closed.
- When the rear backrest is folded down do not allow passengers to occupy the load surface available while the vehicle is in motion. Vehicle occupants must always be properly restrained.

- Never store any heavy, hard objects on the rear lid cover. This can be hazardous for rear seat occupants if the rear lid is opened or if the vehicle is braked suddenly or in the event of a crash.
- Loose items inside the passenger compartment, can fly forward in a crash or sudden maneuver and injure occupants. Always store articles in the luggage compartment and use the fastening eyes, especially when the rear seatbacks have been folded down.
- Read and heed all WARNINGS ⇒ page 93, *Proper seating positions for passengers in rear seats.*

### Rear window shelf

You can place light articles of clothing on the rear window shelf behind the seatback.

### WARNING

Whenever you are driving, do not leave any hard objects on the rear window shelf or allow your pet to sit on the shelf. These could become a hazard for vehicle occupants in the event of sudden braking or a crash!

### Tips

- A vent slot is located between the shelf and the rear window. Do not block the vent with any items you may place on the rear window shelf.
- Do not place bulky items on the rear window shelf as they would restrict or block the driver's vision through the rear view mirror.

## Luggage compartment

### Expanding the luggage compartment

You can increase the available luggage space by folding the rear seatback down.

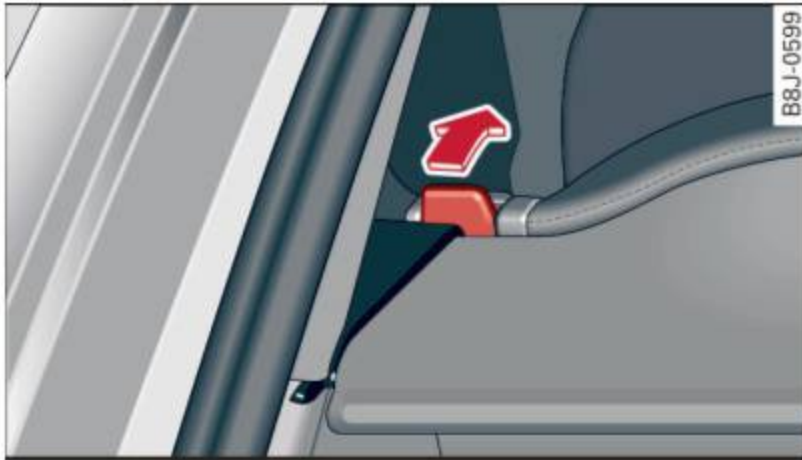

Fig. 59 Unlocking lever of the backrest (left side)

### Tilting the seatback forward

- ▶ Press the lever ⇒ *fig. 59* in the direction of the arrow.
- ▶ Tilt the seatback forward.

### Returning the seatback to its original position

- ▶ Tilt the seatback until it latches securely ⇒

You can fold down both parts of the seatback either separately or together to increase the size of the luggage compartment.

### Stowing luggage

Follow instruction ⇒ *page 96*.

#### WARNING

- The backrest must always be securely latched so that the safety belt can work properly to help protect the occupant.
- The backrest must be securely latched in position so that no items contained in the luggage compartment can slide forward upon sudden braking.
- Never allow safety belts to become damaged by being caught in door or seat hardware.
- Torn or frayed safety belts can tear and damaged belt hardware can break in a crash. Inspect the belts periodically. Belts showing damage to webbing, bind-

ings, buckles, or retractors must be replaced.

#### WARNING

Always read and heed WARNINGS ⇒ in *Loading the luggage compartment on page 96*.

#### Note

When folding the backrest back into place, make sure the safety belt does not get caught, because it can be damaged. A damaged belt can fail to provide safe restraint.

### Fastening eyelets

The luggage compartment is equipped with four tie-down eyelets to secure luggage and other items.



Fig. 60 Luggage compartment: fastening eyes

- ▶ Use the tie-down eyelets to secure your cargo properly ⇒ *fig. 60 -arrows-*.
- ▶ Read and heed all warnings ⇒ *page 96, Stowing luggage*.

In a collision, the laws of physics mean that even smaller items that are loose in the vehicle will turn into heavy missiles that can cause serious injury. Items in the vehicle pick up kinetic energy which varies with vehicle and the weight of the item. The vehicle speed is the most significant factor.

For example, in a frontal collision at a speed of 30 mph (48 km/h), the forces acting on a 10 lbs (5 kg) object are about *20 times* the normal weight of the item. This means that the weight of the item would suddenly be

about 200 lbs (90 kg). One can easily imagine the injuries that an item of that weight flying freely through the passenger compartment can cause in a collision at a speed considered relatively low.

### **! WARNING**

Weak, damaged or improper straps used to secure items to tie-downs can fail during hard braking or in a collision and cause serious personal injury.

- Always use suitable mounting straps and properly secure items to the tie-downs in the luggage compartment to help prevent items from shifting or flying forward as dangerous missiles.
- When the rear seat backrest is folded down, always use suitable mounting straps and properly secure items to the tie-downs in the luggage compartment to help prevent items from flying forward as dangerous missiles into the passenger compartment.
- Never attach a child safety seat tether strap to a tie-down.

### Luggage compartment cover removal and installation

*The luggage compartment cover prevents people from looking into the luggage compartment.*

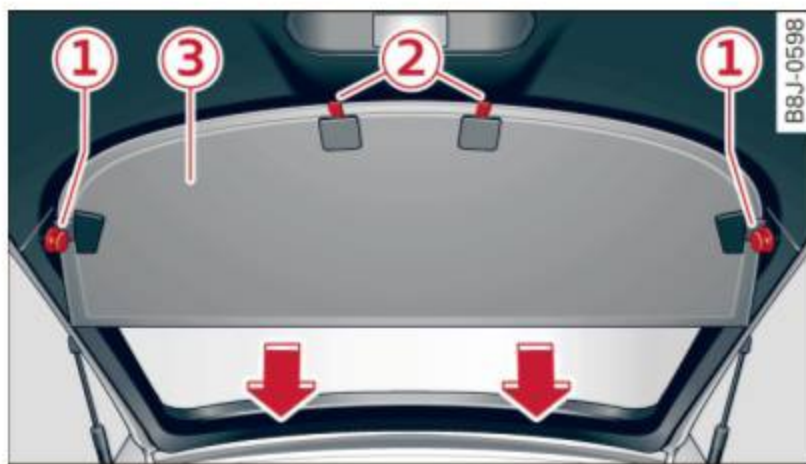

Fig. 61 Open rear lid with luggage compartment cover

### Removing the luggage compartment cover

- ▶ Pull the buttons (1) ⇒ fig. 61
- ▶ Pull the cover (3) out of the brackets (2) ⇒ fig. 61 in the direction of the arrow.

### Replacing the luggage compartment cover

- ▶ Push the cover up into the brackets (2).
- ▶ Press the buttons (1) onto the ball heads.

### **! WARNING**

Never store or place heavy objects on the luggage compartment cover. If you leave something heavy on the cover and then open the cover, the object could slide forward and injure anyone sitting in the rear. Also, in the case of sudden braking or a crash, a heavy object on the cover could fly forward and injure any passengers.

## Roof rack

### First things first

*A roof rack can be fitted to carry additional luggage on the roof.*

- ▶ Always read and follow the instructions provided by the roof rack manufacturer when the roof rack system must be installed.

If you are transporting luggage or other objects on the roof, please note the following:

- Your vehicle has specially designed aerodynamic roof rails. Only install a roof rack specifically designed for your model. Contact the nearest Audi dealer for information on approved modular roof racks for your vehicle.
- These approved roof racks are the basis for a complete roof rack system. Additional attachments for the basic roof rack are necessary to safely transport luggage, bicycles, surf boards, skis or small boats. All necessary hardware for these systems is available at your authorized Audi dealer.
- We recommend that you keep the installation instructions for your roof rack system together with your Owner's literature in the vehicle.

### When should the roof rack be removed?

- Before going through an automatic car wash (it is best to ask the car wash operator for advice).
- When not in use, to reduce fuel consumption, wind noise and to guard against theft.

#### WARNING

- Use of an unapproved roof rack or incorrect mounting of an approved roof rack can cause the roof rack or the items attached to it to fall off the roof onto the road.
- Objects falling from the roof of a vehicle can cause a crash and personal injury.
- Only mount the system between the markings shown in ⇒ page 61, fig. 62.
- The roof rack system must be installed exactly according to the instructions provided.

#### Note

- Your vehicle warranty does not cover any damages to the vehicle caused by using roof racks or mounting structures not approved by Audi for your vehicle. The same applies to damage resulting from incorrect roof rack installation.
- Always check the roof rack mountings and hardware before each trip and during a trip to make sure everything is securely tightened. If necessary, retighten the mountings and check the entire system from time to time.
- After mounting a roof rack system, or when you transport objects on the roof of your vehicle, the height of the vehicle is naturally increased. Be careful when driving under low bridges or in parking garages for example. This could cause damage to the load and even the vehicle itself.

### Mounting locations

The roof rack must be attached only at the positioning bolts.



Fig. 62 Mounting locations for roof rack

### Installation

When installing the feet make sure that they are positioned exactly on the positioning bolts provided  between the side panel and the upper roof frame ⇒ fig. 62. The positioning bolt is visible as soon as the lip of the sealing strip is pushed back from the roof frame with the tool provided.

### Loading the roof rack

Always distribute the loads evenly. Make sure anything on the roof rack is securely tied down.

- ▶ Always distribute the loads on the roof rack evenly.
- ▶ Always attach items to the roof rack securely before you drive off.

The maximum permissible roof weight is **165 lb (75 kg)**. The roof weight is made up of the weight of the roof rack system and the weight of the object being transported.

When using a roof rack system which has a lower load carrying capacity, you must not use up the total maximum permissible load carrying capacity specified above. Instead, you should load the roof rack system only to the maximum capacity specified by the manufacturer of the roof rack system. ▶

**! WARNING**

Weak, damaged or improper straps used to secure items to the roof rack can fail during hard braking or in a collision and cause serious personal injury.

- Make sure the roof rack is installed exactly as specified above ⇒ *page 61*.
- Always use suitable mounting straps for securing items to the roof rack to help prevent items from shifting or flying forward.
- Items on the roof rack must always be securely mounted.
- The use of a roof rack can negatively affect the way a vehicle handles. Cargo that is large, heavy, bulky, long or flat will have a greater negative influence on the vehicle's aerodynamics, center of gravity and overall handling. Always drive slowly, avoid sudden braking and maneuvers when transporting cargo on the roof of your vehicle.
- Never exceed the maximum permissible load carrying capacity of the roof of your vehicle, the permissible axle weights and the permissible total weight of your vehicle ⇒ *page 238, Weights*.

**🌳 For the sake of the environment**

As a result of the increased wind resistance created by a roof rack, your vehicle is using fuel unnecessarily. So remove the roof rack after using it.

**Cup holder**

Fig. 63 Cup holder

**! WARNING**

Spilled hot liquid can cause an accident and personal injury.

- Never carry any beverage containers with hot liquids, such as hot coffee or hot tea, in the vehicle while it is moving. In case of an accident, sudden braking or other vehicle movement, hot liquid could spill, causing scalding burns. Spilled hot liquid can also cause an accident and personal injury.
- Use only soft cups in the cupholder. Hard cups and glasses can cause injury in an accident.
- Never use the cupholder or adapter as an ashtray - risk of fire.

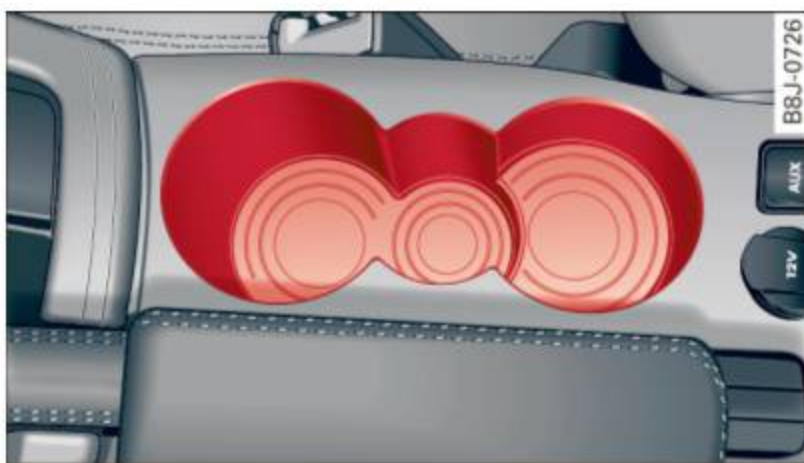
**! Note**

Only drink containers with lids should be carried in the cupholder. Liquid could spill out and damage your vehicles electronic equipment or stain the upholstery, etc.

**Ashtray**

Fig. 64 Center console: ashtray

**Opening the ashtray**

- ▶ Slide the cover open.

**Removing ashtray insert**

- ▶ Press the release button ⇒ *fig. 64*.
- ▶ Pull the ashtray insert up and out.

**To reinstall ashtray**

- ▶ Press the ashtray insert back into its holder. ▶

**! WARNING**

Never put waste paper in the ashtray. Hot ashes or other hot objects in the ashtray could set waste paper on fire.

## Cigarette lighter/ socket

### Cigarette lighter



Fig. 65 Open ashtray with cigarette lighter

The cigarette lighter or socket only work with the ignition on.

### Using the cigarette lighter

- ▶ Slide the cover open to reach the cigarette lighter.
- ▶ Push the knob ⇒ *fig. 65* in.
- ▶ Wait until the cigarette lighter knob pops out.
- ▶ Remove the cigarette lighter immediately and use it.
- ▶ Reinsert cigarette lighter into the socket after use.

### Connecting an appliance

- ▶ Slide the cover open to reach the cigarette lighter.
- ▶ Remove cigarette lighter.
- ▶ Plug in appliance to be used.

The socket of the cigarette lighter may be used for 12-volt appliances with maximum consumption of up to 100 watts, such as a flash light, small vacuum cleaner, etc.

Before you purchase any accessories, always read and follow the information in ⇒ *page 245, Additional accessories and parts replacement.*

**! WARNING**

Improper use of the cigarette lighter can cause serious injury or start a fire.

- Be careful when using the cigarette lighter. If you do not pay attention to what you are doing when you are using the cigarette lighter you can burn yourself.

**! Note**

- To avoid damaging the socket, only use plugs that fit properly.
- Only use the cigarette lighter socket as a power source for electrical accessories for short durations. Use the sockets in the vehicle when a power source is needed for longer durations.

**i Tips**

- When the engine is off and accessories are still plugged in and are on, the vehicle battery can still be drained.
- The vehicle battery must not be charged with a standard small charger that plugs into the cigarette lighter or outlet.

### Outlet

The outlet in the front center console may be used for 12-volt appliances.



Fig. 66 Center console, front: 12-volt outlet

- ▶ Fold the cover for the outlet up.
- ▶ Plug in appliance to be used.

The outlet may be used for 12-volt appliances with maximum consumption of up to 100 watts, such as a flash light, small vacuum cleaner, etc.

Before you purchase any accessories, always read and follow the information in ⇒ *page 245, Additional accessories and parts replacement.*

### **WARNING**

The outlet plus any appliances plugged into it remain functional even if the ignition is switched off or the ignition key is removed. Never leave children inside the vehicle without supervision.

### **Note**

To avoid damaging the socket, only use plugs that fit properly.

### **Tips**

When the engine is off and accessories are still plugged in and are on, the vehicle battery can still be drained.

## Storage

### General

### **WARNING**

- Always remove objects from the instrument panel. Any items not put away could slide around inside the vehicle while driving or when accelerating or when applying the brakes or when driving around a corner.
- When you are driving make sure that anything you may have placed in the center console or other storage locations cannot fall out into the footwells. In case of sudden braking you would not be able to brake, depress the clutch or accelerate.
- Any articles of clothing that you have hung up must not interfere with the driver's view. The coat hooks are designed only for lightweight clothing. Never hang any clothing with hard, pointed or heavy objects in the pockets on the coat hooks. During sudden braking or in an accident - especially if the airbag is deployed -

these objects could injure any passengers inside the vehicle.

### Glove compartment

*The glove compartment is illuminated and can be locked.*

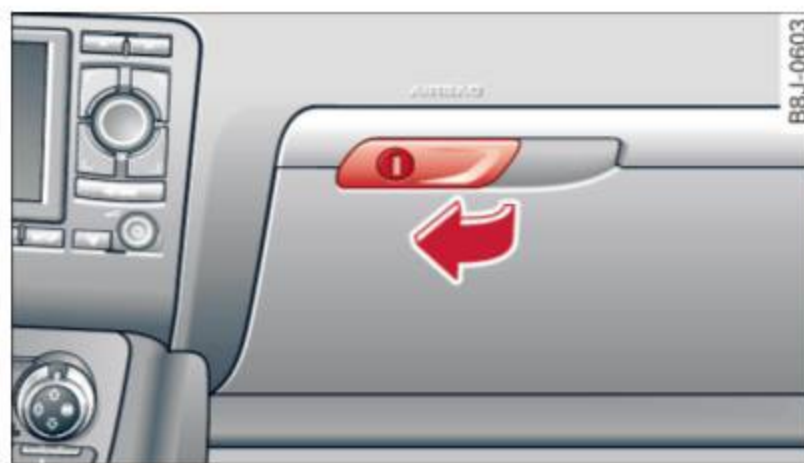

Fig. 67 Glove compartment

#### To open glove compartment

- ▶ Pull the handle ⇒ *fig. 67* in the direction of the arrow push down lid to the fully open position.

#### To close glove compartment

- ▶ Push the glove compartment lid upward until the lock engages.

#### CD changer\*

The CD changer for the Sound System is located in the glove compartment.

### **WARNING**

To reduce the risk of personal injury in an accident or sudden stop, always keep the glove compartment closed while driving.

### Storage compartment in the front seats

Applies to vehicles: with storage compartment in the front seats

*There is a fold-out storage compartment in the front of the seats.*

#### Opening

- ▶ Lift the handle and pull the drawer out.

#### Closing

- ▶ Push the drawer in completely until it latches.

 **Tips**

The maximum carrying capacity 2.2 lbs (1 kg).

**Coat hooks** **WARNING**

- Hang clothes in such a way that they do not impair the driver's vision.
- The coat hooks must only be used for lightweight clothing. Do not leave any heavy or sharp edged objects in the pockets which may interfere with the side air-bag deployment and can cause personal injury in a crash.
- Do not hang heavy objects on the coat hooks, as they could cause personal injury in a sudden stop.

## Warm and cold

### Climate controls

#### Controls

The air conditioning automatically maintains the selected temperature in the vehicle interior throughout each season.

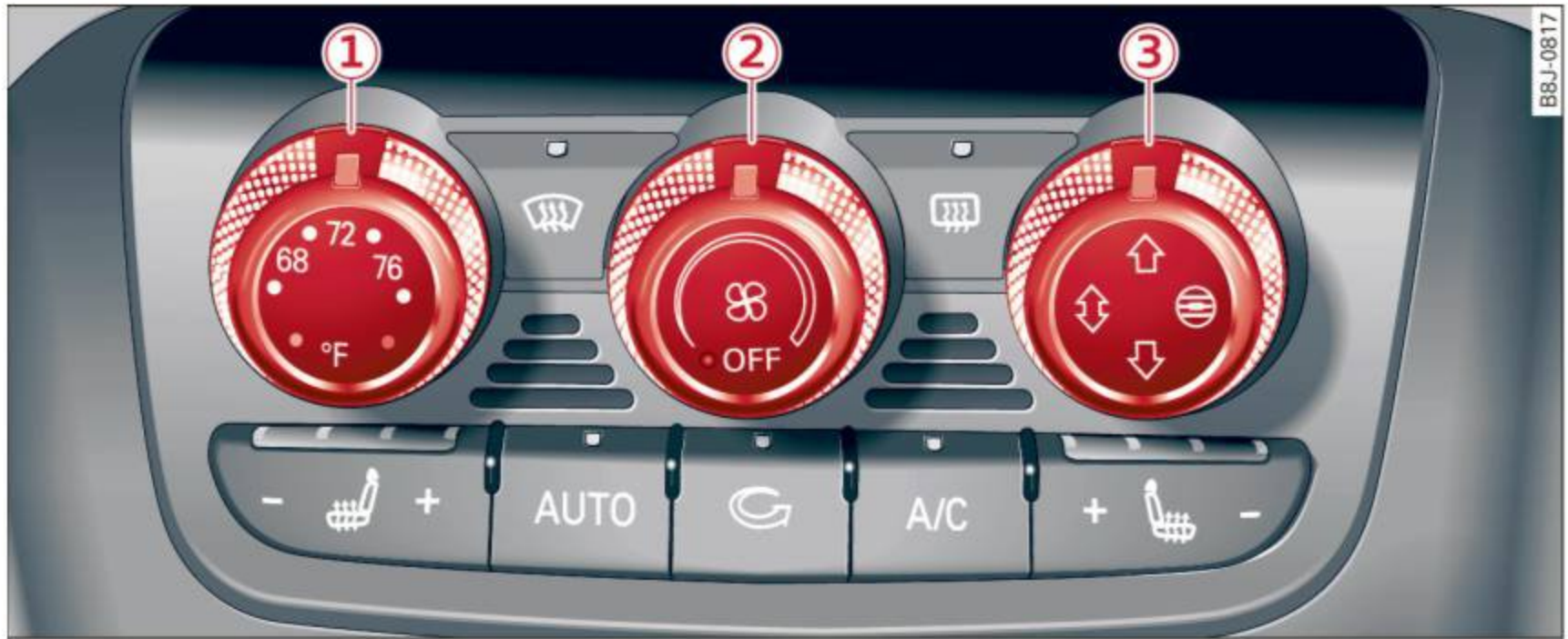

Fig. 68 Climate controls

We recommend the following setting:

- ▶ Rotate the knob ⇒ *fig. 68* ② to the right to switch on the air conditioning.
- ▶ Set the temperature to 72 °F (22 °C).
- ▶ Press the **AUTO** ⇒ *fig. 68* button.

Using the previously recommended setting is the quickest way to achieve a comfortable climate in the vehicle. This setting should therefore only be changed when personal comfort levels or certain circumstances require it.

The climate controls are a combination of automatic heating and ventilation systems and a cooling system which dehumidifies and cools the air inside the vehicle.

The climate controls automatically maintain a temperature once it has been set. The temperature of the air from the vents, fan speed (air volume) and air distribution are also automatically adjusted. The system also takes into account strong sunshine so that manual adjustment is not necessary. So in almost all cases, **automatic mode** offers the best conditions for the comfort of the occupants at all times of the year ⇒ *page 69*.

#### Please note:

In cooling mode, relative humidity in the interior is reduced. This prevents the windows from fogging up.

When relative humidity and temperatures outside are high, **condensation** can drip from the air conditioning evaporator and form a pool of water under the vehicle. This is normal and not an indication of a leak!







When outside temperatures are low, the fan does not switch to a higher speed until the coolant has reached an adequate temperature, with the exception of the defrost setting.

When accelerating at wide-open throttle, the air conditioning compressor is temporarily switched off to maintain full engine power.

In order to ensure engine cooling under extreme engine loads, the compressor is switched off if coolant temperatures climb too high.

Functions are set by turning the rotary knob or switched on and off by tapping the buttons. ►

The LED in the buttons illuminates when the function is active.

Button(s)	Meaning
Rotary knob ①	Temperature selection ⇒ page 67
Rotary knob ② 	Switch air conditioning on/off (Fan) ⇒ page 67
Rotary knob ③	Air distribution ⇒ page 68
	Defrost ⇒ page 69
	Rear window defogger ⇒ page 70
	Heated seat* driver/passenger side ⇒ page 70
	Recirculation ⇒ page 69
	Switch on cooling system ⇒ page 69

### Pollutant filter

The pollutant filter (particle filter) ensures that contaminants in the outside air (such as dust or pollen) are greatly reduced or stopped. The air is also filtered in recirculation mode.

The pollutant filter element must be changed according to the intervals specified in the maintenance schedule so that the air conditioning system's performance is not adversely affected.

If the filter's effectiveness is weakened by driving the vehicle in areas with heavily polluted outside air, the filter element should also be changed in between the listed services.

### WARNING

For safety reasons, it is important that all windows are free of ice, snow, and condensation. Only then is good visibility ensured. Please familiarize yourself with the correct operation of the air conditioning and how to dehumidify/defrost the windows.

### Note

- If you suspect that the climate controls have been damaged, switch the system off to avoid damaging it, and have it inspected by an authorized Audi dealer.
- Audi climate control system repairs require special expertise and the proper tools. You should contact an authorized Audi dealer in the event of malfunctions.

### Tips

- To avoid adversely affecting heating and cooling performance and to prevent condensation on the windows, the air intake in front of the windshield must be free of ice, snow, and leaves.
- The air coming from the vents and circulating through the entire interior is extracted through the outlet slots in the side panels in the luggage compartment. Make sure that the outlet slots are not covered by clothing, etc.
- Climate control works most effectively if the windows are closed. However, if the interior of a parked vehicle is extremely hot from the sun's rays, briefly opening the windows can speed up the cooling process.

### Setting temperature

- ▶ Turn the rotary knob ① ⇒ page 66, fig. 68 to the desired temperature setting.

To set a lower temperature, turn the rotary knob to the left. To set a higher temperature, turn the rotary knob to the right. There are additional intermediate settings available to adjust the temperature as needed.

### Switching climate control on and off

#### Switching the climate control system on and off

- ▶ Turn the knob ② ⇒ page 66, fig. 68 to the right to switch climate control on. The LED next to the word OFF goes out.

- ▶ Turn the knob ② ⇨ *page 66, fig. 68* to the left to switch the climate control system off. The LED next to the word OFF comes on.

### Setting fan speed

- ▶ Turn the knob ② ⇨ *page 66, fig. 68* to the setting you want to adjust fan speed (air quantity).

In automatic mode the climate control system automatically regulates fan speed depending on interior temperature. You can ad-

just the volume of air produced by the fan to meet your own requirements.

### Tips

If the difference between the desired temperature set by you and the vehicle's interior temperature is too great, the fan speed will change automatically. This is done so that the desired temperature setting is reached as quickly as possible.

## Air distribution

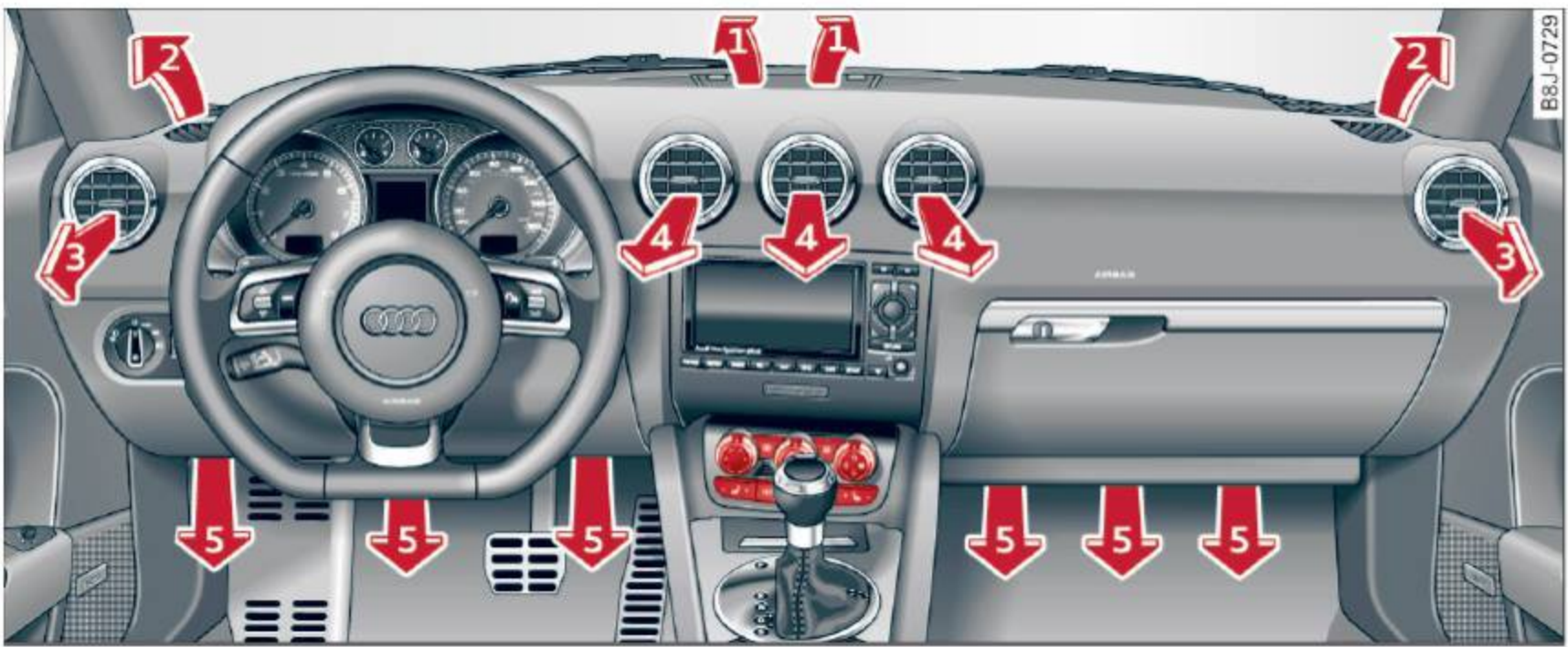





Fig. 69 Instrument panel: Location of air vents

- ▶ Turn the rotary knob ③ ⇨ *page 66, fig. 68* to the desired setting.
- ▶ To open and close the outlets, turn the adjusting ring.
- ▶ To adjust the direction of the airflow from the outlet, move the tab in the center of the outlet in the desired direction. The direction of the air delivered from the vents can be adjusted horizontally and vertically.

### Air distribution:

- In setting , air flows only to the windows, vents ① and ② are open. To defrost the driver and front passenger side windows most effectively, the vents ② should be directed toward the side windows.
- In setting , air flows only to the driver/passenger, vents ③ and ④ are open.

- In setting , air flows only to the footwell, vents ⑤ are open.
- In setting , air flows only to the windows and the footwell, vents ①, ② and ⑤ are open.



There are additional combinations (through intermediate settings) available to adjust air distribution as needed.

### Tips

If the climate controls are running in cooling mode, air should flow mainly from vents ② and ③. To achieve sufficient cooling, you should never close these vents completely.

## Defrost

The windshield and side windows are defrosted or cleared of condensation as quickly as possible.

- ▶ To turn on the defogger/defroster, press the  button ⇒ page 66, fig. 68.
- ▶ To turn the defogger/defroster off, press the  button again, or the **AUTO** button.

Temperature is controlled automatically. The maximum amount of air flows mainly from vents 1 ⇒ page 68.

A small amount of air flows from vents 2 - if they are open ⇒ page 68.

Pressing the  button switches off recirculation mode.

## Automatic operation **AUTO**

Standard operating mode at all times of the year.

### Turning on automatic operation



- ▶ Set the temperature you want.
- ▶ Press the **AUTO** button ⇒ page 66, fig. 68.

Automatic operation ensures constant temperatures in the interior and dehumidifies the air inside the vehicle. Air temperature, volume, and distribution are controlled automatically to reach or maintain the desired interior temperature as quickly as possible. Fluctuations in exterior temperature and the effects of temperature from the position of the sun are compensated for automatically.

## Manual air recirculation mode

The recirculation mode prevents polluted outside air from entering the vehicle interior.

### Switching on air recirculation

- ▶ Press the button  ⇒ page 66, fig. 68 ⇒ .

### Switching off air recirculation

- ▶ Press the button  again, or
- ▶ Press the **AUTO** button, or

- ▶ Press the  button.

In recirculation mode, air is drawn from the vehicle interior, filtered, and recirculated. We recommend that you select recirculation mode *briefly* ⇒  under the following conditions:

When driving through a tunnel or in a traffic jam so that exhaust fumes and odors cannot enter the vehicle interior.

### WARNING

You should not use the recirculation mode for an extended period since no fresh air is drawn in, and with the air conditioning switched off the windows can fog up - this increases the risk of an accident!

## A/C operation **A/C**

### Switching on A/C

- ▶ Press the **A/C** button ⇒ page 66, fig. 68.

### Switching A/C off

- ▶ Press the **A/C** button again.

The air is not cooled and humidity is not removed when cooling mode is switched off. This can cause fog on the windows. Cooling mode switches off automatically when the outside temperature is below zero.

### Tips

If the LED in the switch stays on after A/C operation has been switched off (= switching the A/C off), there is a fault in an air conditioning component. Please consult an authorized Audi dealer when there is an operating problem.

## Using the climate controls economically

Economical use of the climate controls helps to save fuel.

When climate control is working in cooling mode, engine performance is reduced and fuel consumption is affected. To keep the time ▶

the air conditioning is on as short as possible, you should do the following:

- ▶ If you would like to save fuel, switch the air conditioning off.
- ▶ If you open the windows while driving, switch the air conditioning off.
- ▶ If the vehicle is extremely hot due to the heat of the sun, briefly open doors and windows.



#### For the sake of the environment

When you save fuel, you reduce emissions from the vehicle.

## Rear window defogger

*The rear window defogger clears the rear window of condensation.*

- ▶ Press the  button ⇒ page 66, fig. 68 to turn the rear window defogger on and off.

The rear window defogger works only when the engine is running. The indicator light in the button illuminates when the rear window defogger is turned on.

The rear window defogger is switched off automatically after 10 to 20 minutes, depending on the outside temperature.

At very low outside temperatures, the rear window defogger can be switched on continuously by pushing the  button for more than 2 seconds. This remains stored until the ignition is switched off. A rear window defogger that was switched on also remains stored for 15 minutes after the ignition is switched off.

If the engine is restarted within these 15 minutes, the rear window defogger is activated for 10 to 20 minutes, depending on outside temperature. With a vehicle that is parked for a short time, the rear window defogger does not need to be manually activated again.



#### For the sake of the environment

As soon as the rear window is clear, you should switch the rear window defogger

off. The reduced power consumption has a beneficial effect on fuel consumption.

## Heated seats

Applies to vehicles: with heated seats

*The seat cushion and the seatback of the front seats can be heated electrically.*

- ▶ Press the heated seats button  ⇒ page 66, fig. 68 to set the level of heating desired.

The range of controls goes from 1 to 3. The heat setting selected is shown by LEDs above the button.



#### WARNING

Individuals with reduced sensitivity to pain or temperature could develop burns when using the seat heating function. To reduce the risk of injury, these individuals should not use seat heating.



#### Note

To avoid damage to the heating elements in the seats, do not kneel on the seats or place heavy loads on a small area of the seat.

## On the road

### Steering

#### Adjusting the steering wheel column

The steering wheel position can be continuously adjusted in height and distance.



Fig. 70 Lever under the steering column

- ▶ Push the lever ⇒ *fig. 70 -Arrow-* ⇒ ⚠.
- ▶ Move the steering wheel to the desired position.
- ▶ Push the lever against the steering column until it locks.

There must be at least 10 inches (25 cm) between your chest and the center of the steering wheel. If you cannot sit more than 10 inches (25 cm) from the steering wheel, see if adaptive equipment is available to help you reach the pedals and increase the distance from the steering wheel.

For detailed information on how to adjust the driver's seat, see ⇒ *page 56*.

#### ⚠ WARNING

Improper use of steering wheel adjustment and improper seating position can cause serious personal injury.

- Adjust the steering wheel column only when the vehicle is not moving to prevent loss of vehicle control.
- Adjust the driver's seat or steering wheel so that there is a minimum of 10 inches (25 cm) between your chest and the steering wheel ⇒ *page 91, fig. 91*. If you cannot maintain this minimum distance, the airbag system cannot protect you properly.

- If physical limitations prevent you from sitting 10 inches (25 cm) or more from the steering wheel, check with your authorized Audi dealer to see if adaptive equipment is available.
- If the steering wheel is aligned with your face, the supplemental driver's airbag cannot provide as much protection in an accident. Always make sure that the steering wheel is aligned with your chest.
- Always hold the steering wheel with your hands at the 9 o'clock and 3 o'clock positions to reduce the risk of personal injury if the driver's airbag deploys.
- Never hold the steering wheel at the 12 o'clock position or with your hands inside the steering wheel rim or on the steering wheel hub. Holding the steering wheel the wrong way can cause serious injuries to the hands, arms and head if the driver's airbag deploys.

## Ignition lock and ignition switch

### Ignition lock

The ignition key starts or stops the engine.

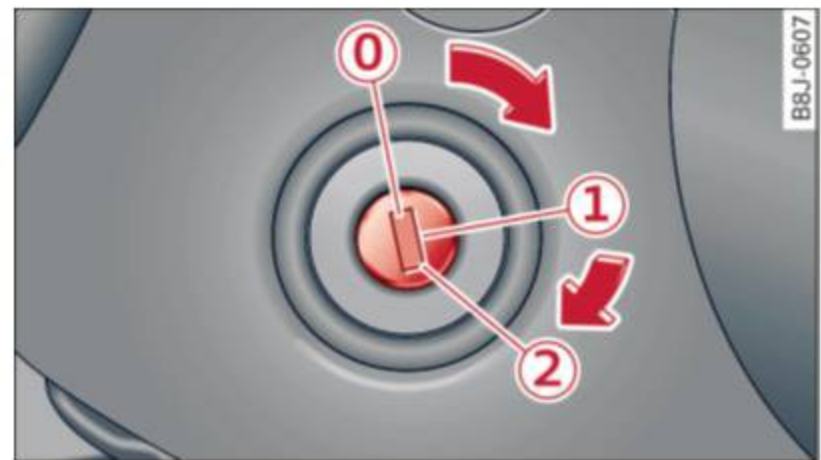

Fig. 71 Ignition lock positions

#### Ignition off ①

In position ⇒ *fig. 71 ①* both the ignition and engine are off, and the steering is locked.

To **lock the steering** after you have removed the ignition key, turn the steering wheel in either direction until you hear it lock into place. You should always lock the steering whenever ▶

you leave your vehicle. This makes a vehicle theft even more difficult ⇒ ⚠.

### Ignition key safety lock

After switching off the ignition, the ignition key can only be removed from the ignition lock when the selector lever is in the “P” (Park) position. After you have removed the key, the selector lever is locked and cannot be moved.

### Ignition on ①

If it is difficult to turn the key after you have inserted it into the ignition lock, turn the steering wheel back and forth. This will take the load off the steering lock mechanism and you will be able to turn the key freely and start the engine.

### Starting the engine ②

In this position the engine starts. While the engine is starting, the power supply to the headlights and other electrical consumers is temporarily interrupted to conserve battery power. After the engine has started, release the key and it will return to position ①.

Before the starter can be operated again the key must be turned back to position ①. The **non-repeat lock** prevents you from damaging the starter when the engine is running.

#### WARNING

- Never remove the key from the ignition lock while the vehicle is moving. The steering wheel will lock causing loss of control.
- If you have to leave your vehicle - even for just a minute - always remove the ignition key and take it with you. This is especially important if you are going to leave children behind in the vehicle. The children could start the engine or use other vehicle controls. Unsupervised use of vehicle controls (for example, power windows) can cause serious personal injuries.

#### Tips

If the vehicle battery has been disconnected and then reconnected, then you must leave the key in position ① for about 5 seconds before you can start the engine.

## Starting and stopping the engine

### Starting the engine

*The engine can only be started with an original Audi key.*

- ▶ Set the parking brake.
- ▶ Move the selector lever to the neutral position (automatic transmission): selector lever in P or N) ⇒ ⚠.
- ▶ On vehicles with manual transmission, fully depress the clutch pedal.
- ▶ Turn the ignition key to position ② ⇒ *page 71, fig. 71* - do not depress the gas pedal when starting the engine!
- ▶ Let go of the key as soon as the engine starts.

A cold engine may at first be loud after it has been started. This is due to the hydraulic valves building up the oil pressure. This normal and no need for concern.

If the engine does not start immediately, stop trying after 10 seconds and then try to restart the engine about 30 seconds later.

#### WARNING

- Never start or let the engine run in a confined or enclosed area. Exhaust fumes from the engine contain carbon monoxide, a colorless and odorless gas. Carbon monoxide can be fatal if inhaled.
- Never leave the engine idling unattended. An unattended vehicle with a running engine poses a danger of personal injury or theft.

### ! Note

- Avoid high engine speeds, fast acceleration or heavy engine loads while the engine is still cold. This could damage the engine.
- The engine cannot be started by pushing or towing the vehicle.

### 🌳 For the sake of the environment

To avoid unnecessary engine wear and to reduce exhaust emissions, do not let your vehicle stand and warm up. Be ready to drive off immediately after starting your vehicle. Maintain moderate speed until the engine is completely warm. Remember, the engine performs best at operating temperature.

## Stopping the engine

- ▶ Turn the ignition key to position ①  
⇒ page 71, fig. 71.

### ⚠️ WARNING

- Never turn off the engine before the vehicle has come to a complete stop. The full function of the brake booster and the power steering is not guaranteed. You must use more force to turn or brake if necessary. Because you cannot steer and brake as you usually would, this could lead to crashes and serious injuries.
- The radiator fan can continue to run for up to 10 minutes even after you have turned off the engine and removed the ignition key. The radiator fan can also turn on again if the engine coolant heats up because of intense sunlight or heat build-up in the engine compartment.

### ! Note

Do not stop the engine immediately after hard or extended driving. Keep the engine running for approximately two minutes to prevent excessive heat build-up.

## Parking brake

### Parking brake

When the parking brake is set, it prevents the vehicle from rolling away unintentionally.

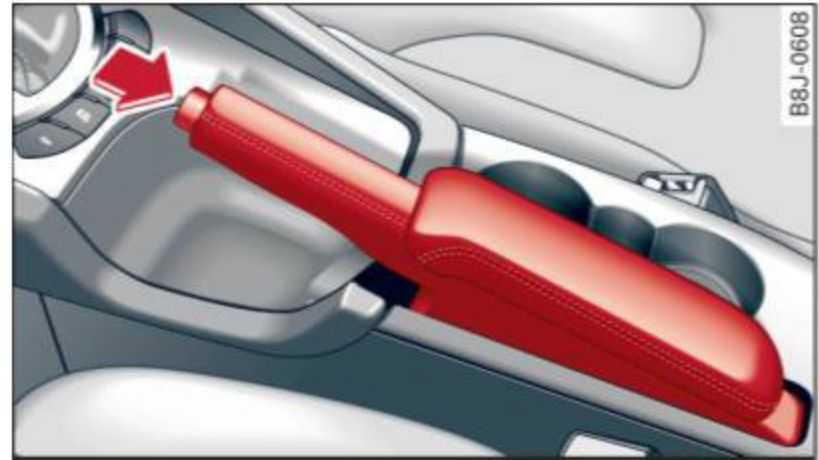

Fig. 72 Center console: Parking brake set

### Setting the parking brake

- ▶ Pull the parking brake lever all the way up.

### Releasing the parking brake

- ▶ Pull the parking brake lever up slightly *and* press the release button at the same time  
⇒ fig. 72 -arrow-.
- ▶ Keep the release button pressed and lower the parking brake ⇒ ⚠️.

If you should drive off with the parking brake still set, a warning tone will sound and the following will appear in the instrument cluster to remind you to release the parking brake:

### Handbrake is applied

The parking brake warning comes on only after you have driven for longer than 3 seconds and faster than 5 mph (5 km/h).

The parking brake warning light **Brake** (USA)/ ⚠️ (CDN) illuminates when the parking brake is set and you switch on the ignition.

### ⚠️ WARNING

Always release the parking brake completely. A partially engaged brake will overheat the rear brakes, reduce their effectiveness and cause excessive wear. This could lead to brake failure and an accident. ▶

**! Note**

Only after the vehicle has come to complete stop, should you firmly set the parking brake and either move the gearshift lever into 1st. gear (manual transmission) or move the selector lever into “P” (Automatic transmission).

**Parking****Parking**

- ▶ Stop the vehicle using the brake pedal.
- ▶ Set the parking brake firmly.
- ▶ Switch off the engine.
- ▶ Move the selector lever into the P position (**automatic transmission**) or move the gearshift lever into 1st. gear (**manual transmission**).
- ▶ Remove the ignition key from the ignition lock.

**In addition on inclines and grades**

- ▶ Turn the steering wheel so that your vehicle will roll against the curb in case it should start to move.

**! WARNING**

This is how you can reduce the risk of injury when leaving your vehicle.

- Never park the vehicle where it can come in contact with dry grass, spilled fuel or any other flammable materials.
- Never allow anyone - especially small children - to remain in the vehicle when it is locked. Locked doors make it more difficult for rescuers to access the passenger compartment in the event of an emergency. Danger to life!
- Never leave children unsupervised in the vehicle. Children could release the parking brake or move the gearshift lever out of gear. The vehicle could start to roll away and cause an accident.
- No matter what the season is, the temperature in a parked vehicle can reach dangerous levels.

**Starting on hills**

Applies to vehicles: with hill hold assist

Hill hold assist makes it easier to start on hills.

The system is activated when the brake pedal is depressed **for a few seconds**.

After releasing the brake pedal, the brake power is held for a *brief moment* to prevent the vehicle from rolling back when starting. At this time, you can easily begin to move your vehicle.

**! WARNING**

- If you did not begin moving immediately after releasing the brake pedal, under certain circumstances, the vehicle would begin to roll backward. Depress the brake pedal immediately or engage the hand brake.
- Should the engine stall, depress the brake pedal immediately or engage the hand brake.
- In order to prevent the vehicle from rolling back unintentionally when starting in stop-and-go traffic, keep the brake pedal depressed for a few seconds before driving off.

**i Tips**

You can find out if your vehicle is equipped with “Hill hold assist” at an authorized Audi dealership.

**Speed warning system****Overview**



*The speed warning system helps you to keep your driving speed below a set speed limit.*

The speed warning system warns the driver if he exceeds a previously stored maximum speed. A warning tone will sound as soon as the vehicle speed exceeds the set speed by about 3 mph (3 km/h). At the same time, a warning symbol appears in the display. ▶

The speed warning system has **two warning thresholds** that function independently of each other and that have somewhat different purposes:

### Speed warning 1

You can use speed warning 1 to set the maximum speed while you are driving. This setting will remain in effect until you turn off the ignition, assuming that you have not changed or reset the setting.



The speed warning symbol  (USA models)/  (Canada models) in the warning 1 display appears when you exceed the maximum speed. It goes out when the speed falls below the stored maximum speed.

The speed warning symbol will also go out if the speed *exceeds* the stored maximum speed by more than about 25 mph (40 km/h) for at least 10 seconds. The stored maximum speed is deleted.

Setting speed warning 1 ⇨ *page 75*.

### Speed warning 2

Storing warning 2 is recommended if you *always* want to be reminded of a certain speed, for example when you are traveling in a country that has a general maximum speed limit, or if you do not want to exceed a specified speed for winter tires.

The speed warning 2 symbol,  (USA models)/  (Canada models) appears in the display when you exceed the stored speed limit. Unlike warning 1, it will not go out until the vehicle speed drops below the stored speed limit.

Setting speed warning 2 ⇨ *page 76*.

#### Tips

Even though your vehicle is equipped with a speed warning system, you should still watch the speedometer to make sure you are not driving faster than the speed limit.



### Speed warning 1: setting a speed limit

Warning threshold 1 is set by the button.





Fig. 73 Section of instrument cluster: Set/Check button

### Storing the maximum speed

- ▶ Drive at the desired maximum speed.
- ▶ Press the knob button ⇨ *fig. 73* until the speed warning symbol  (USA models)/  (Canada models) appears.

### Resetting the maximum speed

- ▶ Drive the vehicle at a speed of at least 3 mph (5 km/h)
- ▶ Press the knob for more than 2 seconds.

The speed warning symbol  (USA models)/  (Canada models) will appear briefly in the display when you release the button to indicate that the maximum speed has been stored successfully.

The maximum speed remains stored until it is changed by pressing the button again briefly or until it is deleted by a lengthy push on the button.

### Speed warning 2: setting a speed limit

Switches in the wiper arm are used to operate warning threshold 2.



Fig. 74 Wiper lever: Trip computer controls

#### To store maximum speed

- ▶ Turn off the ignition.
- ▶ Briefly press the button in the instrument cluster ⇒ page 75, fig. 73. The odometer and the digital clock are now illuminated.
- ▶ Press the button for at least 2 seconds. The currently stored maximum speed appears in the display or the crossed out symbol for warning threshold 2, if no maximum speed was set previously.
- ▶ Press the function selector switch in the wiper lever (A) ⇒ fig. 74 up or down to change the set value. Values run up or down in steps of 6.2 mph (10 km/h).

#### To delete maximum speed

- ▶ Turn off the ignition.
- ▶ Briefly press the button in the instrument cluster ⇒ page 75, fig. 73. The odometer and the digital clock are now illuminated.
- ▶ Press the button for at least 2 seconds. The currently stored maximum speed appears in the display.
- ▶ Press the reset button in the wiper lever (B) ⇒ fig. 74 until the crossed out speed warning symbol for warning threshold 2 appears in the display.

A few seconds after the adjustment is completed, the illumination for the odometer and the digital clock will go out.

### i Tips

This warning threshold can also be controlled through the trip computer ⇒ page 25, Navigating the menu.

## Cruise control

### Switching the system on

The cruise control system makes it possible to drive at a constant speed starting at 20 mph (30 km/h).

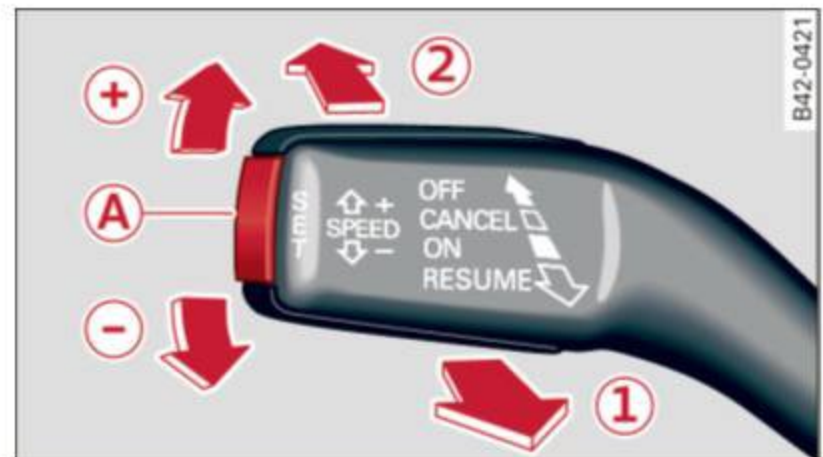



Fig. 75 Control lever with set button



Fig. 76 Display: Selected speed

- ▶ Pull the lever to position (1) ⇒ fig. 75 to switch the system on.
- ▶ Drive at the speed you wish to set.
- ▶ Press button (A) to set that speed.

The display ⇒ fig. 76 will show the set speed. The display may vary depending on the type of display in your vehicle. The indicator light **CRUISE** (US model) /  (Canadian model) will also light up in the instrument cluster.

### ! WARNING

- Always pay attention to traffic even when the cruise control is switched on. You are always responsible for your speed and



the distance between your vehicle and other vehicles.

- For safety reasons, the cruise control should not be used in the city, in stop-and-go traffic, on twisting roads and when road conditions are poor (such as ice, fog, gravel, heavy rain and hydroplaning) - risk of accident.
- Turn off the cruise control temporarily when entering turn lanes, highway exit lanes or in construction zones.
- Please note that inadvertently “resting” your foot on the accelerator pedal causes the cruise control not to brake. This is because the cruise control is overridden by the driver's acceleration.

### Tips

- Vehicles with manual transmission: You can attain the set speed only if the currently engaged gear allows it and the engine is not stressed. Shifting to a higher or lower gear promptly will allow the engine to run smoothly.
- The cruise control cannot maintain a constant speed when driving downhill. The vehicle will accelerate under its own weight. Downshift to a lower gear or use the brakes to slow down.

## Changing speed



- ▶ Press lever in the  or  direction ⇒ *page 76, fig. 75* to increase or decrease your speed.
- ▶ Release the lever to save that speed.

You can also press the accelerator pedal down to increase your speed, e.g. if you want to pass someone. The speed you saved earlier will resume as soon as you release the accelerator pedal.

If, however, you exceed your saved speed by 5 mph (10 km/h) for longer than 5 minutes, the cruise control will turn off temporarily. The symbol will go out but the saved speed will be retained.

## Presetting your speed

*You can preset your desired speed while the vehicle is not moving.*

- ▶ Turn on the ignition.
- ▶ Pull lever into position  ⇒ *page 76, fig. 75*.
- ▶ Press the lever in the  or  direction to increase or decrease your speed.
- ▶ Release the lever to save that speed.

This function makes it possible, for example, to save the speed you want before driving on the highway. Once on the highway, activate the cruise control by pulling the lever toward .

## Switching the system off

### Temporary deactivation

- ▶ Press the brake pedal, or
- ▶ Keep the clutch pedal pressed down longer, or
- ▶ Press the lever into position  (not clicked into place) ⇒ *page 76, fig. 75*, or
- ▶ Drive for longer than 5 minutes at more than 5 mph (10 km/h) above the stored speed.

### Switching off completely

- ▶ Press lever into position  (clicked into place), or
- ▶ Switch the ignition off.

The system retains the saved speed if you deactivate the cruise control temporarily. To resume the saved speed, release the brake or clutch pedal and pull the lever to position .

Switching the ignition off erases the saved speed.

### WARNING

You should only return to the saved speed if it is not too fast for the current traffic conditions - risk of an accident!

## Audi magnetic ride

Applies to vehicles: with magnetic ride

*Damping can be adjusted to the driver's preference and it adapts automatically to the current driving situation.*



Fig. 77 Center console: Switch for Audi magnetic ride

- ▶ Press the switch ⇒ *fig. 77* to turn sport setting on or off.

Audi magnetic ride is an electronically controlled damping system. This chassis system assists the driver by adapting to the particular situation through imperceptible control processes. The **damping** provides individual modulation of damping forces. For example, with damping characteristics set to provide greater comfort, damping is set somewhat harder for a brief period only as required, when rounding a curve and when braking.

### Standard setting

Select the standard setting if you prefer a suspension setting emphasizing comfort.

### Sport setting

Select the sport setting if you prefer a sporty suspension setting. The LED in the switch  comes on to indicate sport setting.

#### Tips

The warning/indicator light  in the instrument cluster comes on in the event of a malfunction. Drive to the closest authorized Audi dealer as soon as possible and have the malfunction repaired.

## Sport mode

Applies to vehicles: with Sport button



Fig. 78 Button in the center console

- ▶ To switch sport mode on, press the button in the center console. The indicator light turns on.
- ▶ To switch sport mode off, press the button in the center console again. The indicator light turns on.

A more agile and sporty driving style is possible when driving the vehicle in “sport mode”. This mode affects throttle response and the sound of the engine and the damping characteristics of the Audi magnetic ride for dynamic suspension tuning.

#### Tips

If there is a malfunction in the retractable rear spoiler\* or the Audi magnetic ride\*, it may not be possible to activate sport mode.

## Acoustic parking system

### Rear acoustic park assist

Applies to vehicles: with 4-channel acoustic park assist

*Acoustic park assist gives a warning about obstacles behind the vehicle.*

#### Description

The rear acoustic park assist (4-channel acoustic park assist) determines the distance of the vehicle from an obstacle using ultrasonic sensors. The sensors are in the rear bumper. The volume and the pitch of the

chimes can be adjusted through the menu display ⇒ *page 24*.

The range at which the sensors start to measure is **about**:

To the side	2 feet (0.60 m)
Center rear	5 feet (1.60 m)

### Activation

The parking assist is activated when **reverse gear** is engaged. A brief tone confirms that the system is activated.

### Backing up

Distance warning when backing up starts when an obstacle is detected in the range of the park assist system. As the distance decreases, the time interval between the audible tones becomes shorter.

When the distance is less than 1 foot (0.30 m), the tone becomes continuous. At this point you should stop backing up.

Please note that low objects already signalled by a warning can disappear from the system's detection range and will not continue to be signalled.

### Potential malfunctions

If a warning buzzer sounds for a few seconds when the ignition is switched on, there is a system malfunction with the acoustic park assist. If the malfunction persists until the ignition is switched off, there will be no acoustic warning at the next attempt to activate the system. Have the problem corrected.

There is no confirmation tone when reverse gear is engaged if there is a system malfunction.

For the parking assist to operate, the sensors must be kept clean and free of ice.

### WARNING

- Sensors have blind spots in which objects cannot be detected. Pay special attention to small children and animals. They can-

not always be detected by the sensors - danger of an accident!

- The parking assist cannot replace the driver's attention. The driver alone is responsible for parking and similar driving maneuvers. Always watch where you are driving.

### Note

Low obstacles already signalled by a warning can disappear from the system's detection range as they are approached and will not continue to be signalled. Objects such as barrier chains, trailer draw bars, thin painted vertical poles, or fences may not be detected by the system - risk of damage.

### Tips

For the parking assist to operate, the sensors must be kept clean and free of snow and ice.

## Transmission

### Manual transmission

#### Gearshift lever

Applies to vehicles: with manual transmission

The clutch pedal must be depressed all the way before you can start the engine.

The manual transmission in your Audi is equipped with an *interlock-feature*.

- ▶ Depress the clutch pedal all the way.
- ▶ Start the engine with the gearshift lever in Neutral and the clutch pedal depressed.

#### ! Note

Always depress the clutch pedal fully when changing gears. Do not hold the vehicle on a hill with the clutch pedal partially depressed. This may cause premature clutch wear or damage.

#### i Tips

- Resting your hand on the gearshift lever knob while driving will cause premature wear in the transmission.
- The back-up lights go on when you shift into Reverse with the ignition on.

#### Gearshift pattern (6-speed manual transmission)

Applies to vehicles: with 6-speed manual transmission

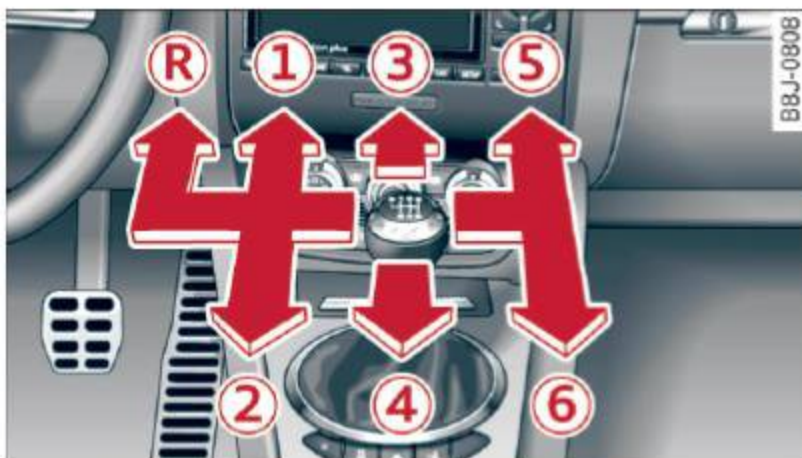

Fig. 79 Gearshift pattern: 6-speed manual transmission

Drive in 6th gear for optimum fuel economy when cruising. However, if more acceleration is required (when passing, for example), shift down.

#### Engaging reverse gear (R)

- ▶ Move the shift lever all the way to the left, press it down, then push it forward.

Especially after driving forward, stop the vehicle completely, shift into *Neutral* and rest the shift lever briefly in Neutral before shifting into *Reverse*.

## S tronic transmission

#### Introduction

Applies to vehicles: with S tronic

Your vehicle is equipped with a S tronic transmission, also called a double-clutch system/transmission.

Power is transferred between the engine and the transmission by means of two independent clutches. They replace the torque converter of conventional automatic transmissions and allow the vehicle to accelerate without a noticeable break in the power flow.

With the aid of **tiptronic**, the gears can optionally be shifted *manually* ⇒ page 84.

#### Selector lever positions

Applies to vehicles: with S tronic

All the selector lever positions are explained in this section.



Fig. 80 Display: Selector lever position

The instrument cluster display shows the selector lever position.

#### P - Park lock

In this position the gears are mechanically locked.

The park lock must only be engaged with the vehicle *stationary* ⇒ ⚠.

To engage P and to remove the lever from this position, you must depress the release button (button in the selector lever handle) *and* simultaneously you must step on the brake pedal.

### R - reverse

In this position, reverse is engaged.

Reverse gear must only be engaged with the vehicle *stationary* and the engine running at idle speed ⇒ ⚠.

To engage R, you have to depress the release button *and* simultaneously step on the brake pedal. In the R position, the back-up lights illuminate with the ignition on.

### N - Neutral

The transmission is in neutral in this position.

### D - Normal position for driving forward

In this position, the forward gears are automatically shifted up and down, depending on engine load and vehicle speed.

To engage D from N, the brake pedal must be depressed at speeds below 5 km/h or when the vehicle is stationary ⇒ ⚠.

In certain circumstances (driving in the mountains for example) it can be beneficial to switch temporarily to the manual shift program ⇒ *page 84* in order to adjust the gear ratios to driving conditions *manually*.

### S - Sport setting

The S setting should be selected for sporty driving. The power reserves of the engine can be fully exploited through later upshifts.

To engage S from N, the brake pedal must be depressed at speeds below 5 km/h or when the vehicle is stationary ⇒ ⚠.

## ⚠ WARNING

- Never place the selector lever in the R or P position while the vehicle is moving - risk of an accident!
- With the engine running, it is necessary to hold the vehicle with the foot brake in all selector lever positions (except P and N), because even at idle speed the transfer of power is never completely interrupted - the vehicle “creeps”. If the vehicle is stationary and the transmission is engaged, the engine should never be speeded up unintentionally (e.g. manually from under the hood). Otherwise the vehicle will immediately start to move - sometimes even if the parking brake is firmly applied - risk of an accident!
- Before you or other persons open the hood and work on a running engine, the selector lever must be moved to P and the parking brake applied firmly - risk of an accident! Follow the warning stickers ⇒ *page 174, Engine compartment*.

## i Tips

If you have inadvertently shifted into N while the vehicle is moving, you should remove your foot from the accelerator and wait until the engine speed has dropped to idle before shifting back to D or S.

## Selector lever lock

Applies to vehicles: with S tronic

*The selector lever lock prevents a gear from being engaged accidentally and unintentionally setting the vehicle in motion.*

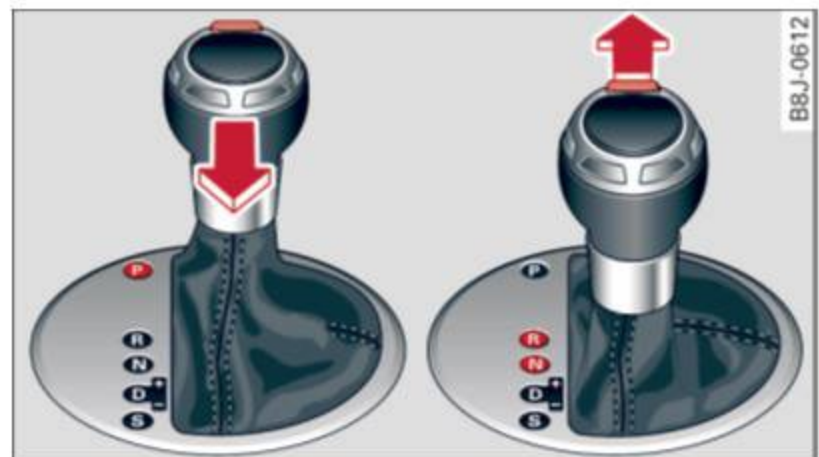

Fig. 81 Selector lever locks

The selector lever lock is released as follows:

- ▶ Switch the ignition on.
- ▶ Step on the brake pedal *and* simultaneously hold down the release button.

### Automatic selector lever lock

The selector lever is locked in the P and N positions when the ignition is on. To move the lever from these positions the driver must depress the brake pedal. As a reminder to the driver, the following warning appears in the instrument cluster display when the selector is in P and N:

### To start engine or select gear apply foot brake when stationary

The selector lever lock is effective only when the vehicle is stationary and at speeds below 5 km/h. At higher speeds, the lock in the N position is automatically switched off.

The selector lever is not locked when rapid shifts are made through the N position (e.g. from R to D). This allows you to “rock” the vehicle if it becomes stuck. If the lever is in the N position for more than 1 second with the brake pedal not depressed, the selector lock engages automatically.

### Release button

The release button in the selector lever handle prevents accidental shifts into certain selector lever positions. When you press the release button, the selector lever lock is cancelled. In the illustration, the positions in which the release button has to be pressed are highlighted in color ⇒ *fig. 81*.

### Ignition key removal lock

The ignition key can only be removed after the ignition is switched off if the selector lever is in P. As long as the ignition key is removed, the selector lever is locked in P.

#### Tips

If the selector lever does not engage, there is a malfunction. The engine is disabled to prevent the vehicle from driving off unintentionally. To allow the selector lever

to engage again, proceed as follows: Press and release the brake pedal.

### Driving Notes

Applies to vehicles: with S tronic

*The forward gears are shifted up or down automatically.*



**Fig. 82** Section from center console: Selector lever with release button

### Starting the engine

- ▶ The selector lever must be in the P or the N position. At low temperatures (below -10 °C), the engine can only be started when the selector lever is in the P position.

### Starting from stop

- ▶ Step on and hold the brake pedal.
- ▶ Hold the release button (button in selector lever) down, move the selector lever to the desired position, for example D ⇒ *page 80*, and release the button.
- ▶ Release the brake pedal and accelerate ⇒ .

### Stopping temporarily

- ▶ Bring the vehicle to a full stop with the brake, e.g. at traffic signals.
- ▶ Do not accelerate.

### Parking

- ▶ Step on and hold the brake pedal ⇒ .
- ▶ Apply the parking brake firmly.
- ▶ Hold the release button down, move the selector lever to P and release the button.

### Stopping on an incline

- ▶ *Always* hold the vehicle with the footbrake or parking brake in order to prevent

“rollback” ⇒ . Do **not** try to prevent the vehicle from rolling back by revving the engine while it is in gear.

### Starting on a hill

- ▶ Apply the hand brake firmly.
- ▶ With the engine in gear, gradually accelerate and release the hand brake.

The engine can only be **started** with the selector lever in P or N ⇒ *page 72*. At low ambient temperatures (14 °F / -10 °C), it is only possible to start the engine with the selector lever in P.

When parking on level ground, it is sufficient to place the selector lever in P. On a steeply sloping road, you should first apply the parking brake firmly and then place the selector lever in P. This way, you do not overload the pawl mechanism and it is easier to move the selector lever out of P.

#### **WARNING**

- Never leave your vehicle with the engine running while in gear. If you must leave your vehicle with the engine running, set the parking brake and engage the park lock.
- When the engine is running and the transmission is in gear (D, S or R) or in “tiptronic” mode, it is essential that you stop the vehicle with the footbrake. When idling, the transmission of power does not stop completely – the vehicle “creeps”.
- Do not accelerate when you change the selector lever position with the vehicle stationary and the engine running - risk of an accident!
- Never place the selector lever in the R or N position while the vehicle is moving - risk of an accident!
- If you have to bring your vehicle to a stop while on an incline, keep the foot brake depressed all the way down so that the vehicle does not start to roll backward. You should never hold the vehicle using the clutch if you are going to be stopped

on an incline. If you do, the clutch will start to slip when it overheats caused by the constant overload. This is dangerous because if the vehicle starts to roll backward, you could cause an accident. If the clutch should start to slip, you will feel the vehicle “jerk” and the selector lever display will start blinking.

- Before driving down a steep slope, reduce your speed and shift into a lower gear with “tiptronic”.
- Do not ride the brakes or apply the brake pedal too often or too long. Constant braking causes the brakes to overheat and substantially reduces braking performance, increases braking distance or causes complete failure of the brake system.

### Hill Descent Assist

Applies to vehicles: with S tronic

*Hill Descent Assist helps the driver when driving down inclines.*

Hill Descent Assist is activated by pressing the brake while descending when the selector lever is in D/S. The S tronic transmission automatically shifts down to a gear suitable for the incline. Hill Descent Assist attempts to maintain the current vehicle speed when the braking occurs, as far as physical and technical limits allow. It may be necessary to adjust the speed using the brakes.

Hill Descent Assist switches off when the incline levels out or when the gas pedal is pressed.

On vehicles with cruise control\* ⇒ *page 76*, Hill Descent Assist is also activated when the speed is set.

#### **WARNING**

Hill Descent Assist cannot overcome physical limitations, so it may not be possible to maintain a constant vehicle speed under all circumstances. Always be ready to apply the brakes.

**tiptronic operation**

Applies to vehicles: with S tronic

*Tiptronic allows the driver to shift gears manually.*



Fig. 83 Center console: Manual shifting (tiptronic)



Fig. 84 Display: Manual shifting (tiptronic)

**Switching to manual**

- ▶ Move the selector lever to the right out of the D position. The display changes once the transmission has switched to manual mode. For example, **M4** indicates that 4th gear is engaged.

**Upshifting**

- ▶ Tap the selector lever forward (in the tiptronic setting) ⇒ *fig. 83* ⊕.

**Downshifting**

- ▶ Tap the selector lever backward (in the tiptronic setting) ⊖.

Switching to manual can be carried out with the vehicle stationary as well as moving.

When accelerating, the transmission shifts into the next gear in gears 1, 2, 3, 4 and 5 shortly before the maximum permissible engine speed is reached.

If you have selected a lower gear than the current one, the transmission will only shift down when the engine cannot be overspeeded.

If kick-down is actuated, the transmission shifts into a lower gear independently of speed and engine rpm.

**Steering wheel with Tiptronic® controls**

Applies to vehicles: with S tronic

*The selector paddles allow the driver to keep both hands on the steering wheel when shifting gears.*



Fig. 85 Sport steering wheel with selector paddles

**Shifting up**

- ▶ Pull the *right* paddle, marked ⊕ ⇒ *fig. 85* briefly towards you.

**Shifting down**

- ▶ Pull the *left* paddle, marked ⊖ ⇒ *fig. 85* briefly towards you.

The selector paddles on the steering wheel are activated when the selector lever on the center console is in D, S or in the manual position (Tiptronic mode).

You can also shift gears in the Tiptronic mode using the selector lever on the center console.

**i Tips**

With the gear selector lever in either D or S the transmission will switch back to the automatic mode if you do not use the paddles within approx. 30 seconds.

### Kick-down feature

Applies to vehicles: with S tronic

*The kick-down feature allows maximum acceleration.*

If you depress the accelerator pedal fully beyond the full-throttle position, the transmission automatically downshifts one gear, depending on vehicle speed and engine rpm. The upshift into the next higher gear takes place as soon as the maximum specified engine speed is reached.

#### WARNING

Please note that the drive wheels can spin if the kick-down is used on a smooth slippery road - risk of skidding!

### Launch Control Program

Applies to vehicles: with S tronic

*The Launch Control Program permits maximum acceleration.*

In order to use Launch Control, the ASR (Anti-Slip Regulation) must be disabled. When ASR is disabled, the ESC warning/indicator light  in the instrument cluster illuminates. So that Launch Control can be used, the engine must be at operating temperature and the steering wheel must not be turned.

- ▶ With the engine running, briefly press the ESC button. The message “Stabilization program off” or “Sport control Warning! Restricted stability” in the driver information system display.
- ▶ Shift the gear lever to “S” or the tiptronic® position.
- ▶ Step on the brake pedal with your left foot and keep the brake pedal fully depressed for at least one second.
- ▶ With your right foot, step on the accelerator to the wide-open throttle position or Kickdown. The engine speed settles at about 3,200 rpm.
- ▶ Take your left foot off the brake.

#### WARNING

- Always adapt your driving to the traffic flow.
- Only use Launch Control when road and traffic conditions allow it and other drivers will not be endangered or annoyed by your driving and the acceleration of the vehicle.
- Make sure that ESC remains enabled. With the ESC disabled, the vehicle could brake away, particularly on a slick and slippery road - risk of skidding!
- Once acceleration is finished, switch ASR on again by briefly pushing the ESC button.

### Back-up program

Applies to vehicles: with S tronic

*In the event of a system malfunction, there is a back-up program.*

In the event of system malfunction, the automatic transmission switches to the fail-safe mode. All of the selector lever position displays for the automatic transmission are highlighted with a light background in the instrument cluster display. In some cases you cannot use reverse gear any more.

If the transmission switches to fail-safe mode, you should take the vehicle to an authorized Audi dealership as soon as possible to have the condition corrected.

### Clutch is overheating

Applies to vehicles: with S tronic

 **Clutch is overheating! Please stop vehicle!**

If the symbols are illuminated, the clutch is overheating and could be damaged if you continue to drive. Stop the vehicle and allow the transmission to cool with the selector lever in the P position while the engine runs at idle. If the warning does not turn off, do not continue driving. See your authorized Audi dealer or

qualified repair facility for assistance. Otherwise serious transmission damage could result. Once the indicator light has turned off, drive to your authorized Audi dealer or qualified repair facility immediately to have the malfunction corrected.

### Selector lever emergency release

Applies to vehicles: with S tronic

*If the vehicle's power supply fails, the selector lever can be released in an emergency.*



Fig. 86 Selector lever: Removing the selector lever boot



Fig. 87 Selector lever: Using the emergency release to move out of the Park position

The emergency release mechanism is located in the right front area under the selector lever shift gate. Using the emergency release can be complicated. We recommend contacting your authorized Audi dealer for assistance, if necessary.

### Removing the selector lever boot

- ▶ Activate the parking brake.
- ▶ Carefully pry the selector lever boot out of the trim **(A)** using a small screwdriver.
- ▶ Pull both sides of the selector lever boot upward in the direction of the arrow **(B)**.
- ▶ Fold the selector lever boot upward.

### Selector lever emergency release

- ▶ Press the release lever down and hold it in place ⇒ *fig. 87*.
- ▶ Press the release button in the selector lever **(C)** and move the lever into the N position.
- ▶ Clip the selector lever boot back into the shift gate after using the emergency release.

If the vehicle must be pushed or towed due to a power failure (for example, the battery is discharged), the selector lever must first be moved to the N position using the emergency release mechanism.

### **!** WARNING

Only move the selector lever out of the P position when the parking brake is activated. Otherwise, the vehicle could start to move unintentionally when the selector lever is moved out of the P position.

## HomeLink®

### Universal remote control

#### General information

The HomeLink universal remote control can be programmed with hand-held transmitters from existing equipment.

You must first program the HomeLink® transmitter before you can use the system  
⇒ page 87, *Programming the HomeLink® transmitter*.

In order to program the HomeLink® transmitter for devices utilizing rolling code, a second person on a ladder who can safely reach the garage door opener motor is recommended. It is also necessary to locate the “learn” button on your garage door opener motor. Refer to the operating instructions for the opener, as the location and color of this button may vary by manufacturer.

You can still use the original remote control for the device at any time.

#### WARNING

- Never use the HomeLink® transmitter with any garage door opener that does not have the safety stop and reverse feature as required by federal safety standards. This includes any garage door opener model manufactured before April 1, 1982.
- A garage door opener which cannot detect an object, signaling the door to stop and reverse does not meet current federal safety standards. Using a garage door opener without these features increases risk of serious injury or death.
- For safety reasons never release the parking brake or start the engine while anyone is standing in front of the vehicle.
- A garage door or an estate gate may sometimes be set in motion when the HomeLink® remote control is being programmed. If the device is repeatedly ac-

tivated, this can overstrain motor and damage its electrical components - an overheated motor is a fire hazard!

- To avoid possible injuries or property damage, please always make absolutely certain that no persons or objects are located in the range of motion of any equipment being operated.

#### Tips

- If you would like more information on HomeLink®, where to purchase the HomeLink® compatible products, or would like to purchase the HomeLink® Home Lighting Package, please call toll-free: 1-800-355-3515.
- For Declaration of Compliance to United States FCC and Industry Canada regulations ⇒ page 246.

#### Programming the HomeLink® transmitter

The transmitter is programmed in two phases. For rolling code transmitters, a third phase is also necessary.

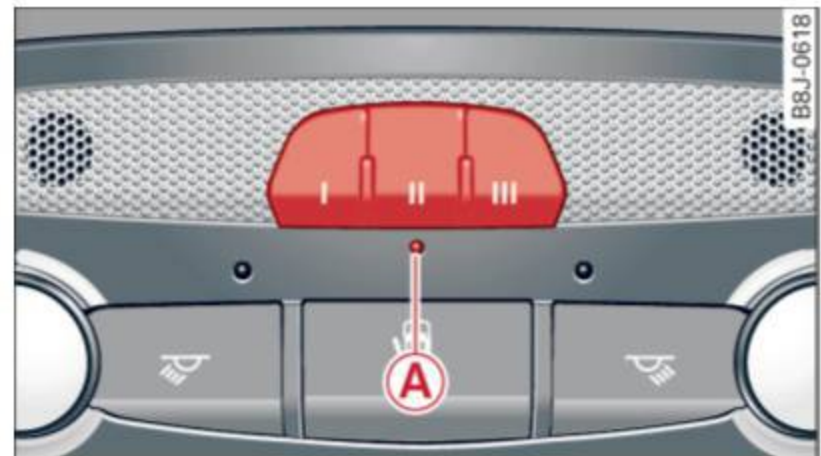









Fig. 88 Overhead console: HomeLink® keypad



Fig. 89 Front bumper, driver side: location of transmitter unit

### Phase 1: programming the overhead keypad

1. Make sure your vehicle is within operating range of the remote controlled garage door opener.
2. Set the parking brake ⇒  in *General information on page 87*.
3. Turn the ignition on. Do not start the engine!
4. Press and hold the two outside HomeLink® buttons  and  for approximately 20 seconds until indicator light  ⇒ *fig. 88* begins to flash. Then release both buttons. Do not hold the buttons for longer than 30 seconds.
  - ▶ This procedure only needs to be performed **once**. It erases the factory-set default codes and does not have to be repeated to program additional remote controls.
5. Press and hold the HomeLink® button ,  or  until the indicator light  starts flashing *slowly*. Release the button.
  - ▶ *The system will remain in programming mode for 5 minutes. Go to the front of the vehicle and proceed with phase 2.*

### Phase 2: programming the bumper mounted transmitter

6. Hold the *original remote control* at a distance between 0–6 in. (0–15 cm) from the bumper below the appropriate headlight for your vehicle ⇒ *fig. 89* (use the shortest distance possible).
7. Aim the remote control just below the **driver side** headlight.
8. Press and hold the activation button on the remote control.
  - ▶ May be different in Canada. If so, press and re-press (cycle) the activation button on your remote control every two seconds.
9. The emergency flashers will flash **three times** (after about 15–60 seconds) when the programming is successful. Release the button on the remote control.
  - ▶ *To program more devices, repeat steps 4 to 9.*

10. Press and hold the trained HomeLink® button and observe the indicator light  ⇒ *fig. 88*.
  - ▶ If the indicator light is solid/continuous, programming is complete and your device should activate when you press and release the trained HomeLink® button.
  - ▶ If the indicator light blinks rapidly for 2 seconds and is then a solid/continuous light, proceed with phase 3 to program a rolling code device.

### Phase 3: rolling code programming

- ▶ A second person on a ladder who can safely reach the garage door opener motor is recommended.
11. Locate the “learn” button on the garage door opener motor (refer to the operating instructions for the opener, as the location of this button may vary by manufacturer).
  12. Press and release the learn button on the garage door opener motor.
    - ▶ **Note:** once the button is pressed, there are **30 seconds** in which to initiate the next step.
  13. On the HomeLink® keypad inside the vehicle, firmly press and hold the HomeLink® button previously programmed in phases 1 and 2 for two seconds and release. Repeat this sequence **twice**.
    - ▶ Some vehicles may require the press/hold/release sequence up to three times to complete the training process.
    - ▶ *HomeLink® should now activate your rolling code equipped device.*

If the 5 minute time limit is exceeded, the **emergency flashers will flash one time** to indicate that the process has been terminated. In this case, repeat steps 4 through 9.

If the emergency flashers do not flash *three* times (after about 15–60 seconds), programming was not successful. In this case, repeat steps 4 through 9.

Remote control units for garage door openers in Canada are set to stop transmitting radio frequency signals after two seconds. This time ▶

may not be sufficient for the HomeLink® system to learn the radio frequency signal. Perform all other steps as described above.

### Operating the HomeLink® transmitter

The HomeLink® transmitter works in the same manner as the original handheld remote control that came with the system.

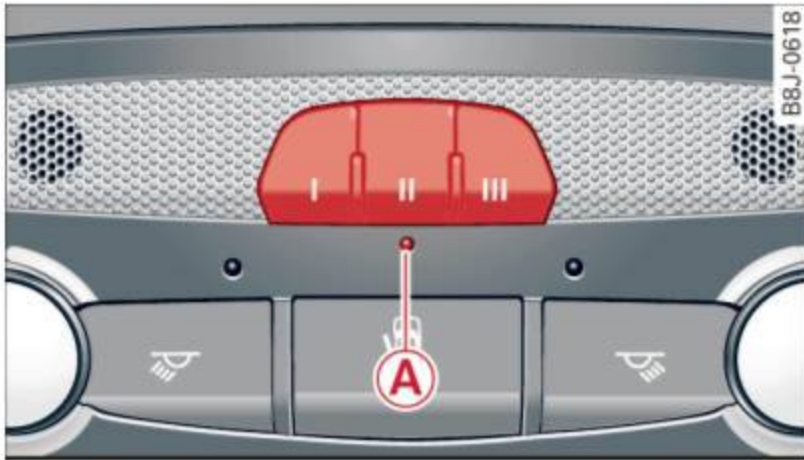



Fig. 90 Overhead console: HomeLink® keypad

- ▶ Press the appropriate programmed button **I**, **II** or **III** to activate the desired remote control function ⇒  in *General information on page 87*.

### Reprogramming a single button

A HomeLink® button can be reprogrammed individually without affecting the other button allocations.

#### Programming the overhead keypad

- ▶ Press the appropriate HomeLink® button until the indicator light begins flashing slowly.

#### Programming the bumper mounted transmitter

1. Hold the *original remote control* at a distance between 0–5 in. (0–13 cm) from the bumper below the appropriate headlight for your vehicle (use the shortest distance possible).
2. Aim the remote control just below the **driver side** headlight.
3. Press and hold the activation button on the remote control.
4. The emergency flashers will flash **three times** (after about 15–60 seconds) when

the programming is successful. Now release the button on the remote control.

- ▶ If the device utilizes a rolling code, please follow phase 3 of ⇒ *page 87, Programming the HomeLink® transmitter* for rolling code programming.

**This procedure will cause the existing programming on the HomeLink® button to be erased!**

### Erasing the programming of the HomeLink® transmitter

When you erase the programming, the programming on all three of the transmitter channels will be lost!

- ▶ Perform steps 1 to 4 as described on ⇒ *page 88, Phase 1: programming the overhead keypad*.

When completed, the HomeLink® system will be in the programming mode and is then ready to learn the codes for remote controlled devices.

#### Tips

- Programmed buttons cannot be erased individually.
- For security reasons you are advised to erase the programming of the HomeLink® system before you sell your vehicle.

## Driving Safely

### General notes

#### Safe driving habits

*Please remember - safety first!*

This chapter contains important information, tips, instructions and warnings that you need to read and observe for your own safety, the safety of your passengers and others. We have summarized here what you need to know about safety belts, airbags, child restraints as well as child safety. Your safety is for us *priority number 1*. Always observe the information and warnings in this section - for your own safety as well as for that of your passengers.

The information in this section applies to all model versions of your vehicle. Some of the features described in this sections may be standard equipment on some models, or may be optional equipment on others. If you are not sure, ask your authorized Audi dealer.

#### WARNING

- Make certain that you follow the instructions and heed the WARNINGS in this Manual. It is in your interest and in the interest of your passengers.
- Always keep the complete Owner's Literature in your Audi when you lend or sell your vehicle so that this important information will always be available to the driver and passengers.
- Always keep the Owner's literature handy so that you can find it easily if you have questions.

#### Safety equipment

*The safety features are part of the occupant restraint system and work together to help reduce the risk of injury in a wide variety of accident situations.*

Your safety and the safety of your passengers should not be left to chance. Advances in technology have made a variety of features available to help reduce the risk of injury in an

accident. The following is a listing of just a few of the safety features in your Audi:

- sophisticated safety belts for driver and all passenger seating positions,
- safety belt pre-tensioners,
- front airbags,
- knee airbags for the front seats,
- side airbags in the front seats,
- LATCH anchorages for child restraints,
- adjustable steering column.

These individual safety features can work together as a system to help protect you and your passengers in a wide range of accidents. These features cannot work as a system if they are not always properly adjusted and properly used!

#### Safety is everybody's responsibility!

#### Important things to do before driving

*Safety is everybody's job! Vehicle and occupant safety always depends on the informed and careful driver.*

For your safety and the safety of your passengers, **before driving always:**

- ▶ Make sure that all lights and signals are operating correctly.
- ▶ Make sure that the tire pressure is correct.
- ▶ Make sure that all windows are clean and afford good visibility to the outside.
- ▶ Secure all luggage and other items carefully ⇒ *page 64*.
- ▶ Make sure that nothing can interfere with the pedals.
- ▶ Adjust front seat, head restraint and mirrors correctly for your height.
- ▶ Instruct passengers to adjust the head restraints according to their height.
- ▶ Make sure to use the right child restraint correctly to protect children ⇒ *page 130, Child Safety*.
- ▶ Sit properly in your seat and make sure that your passengers do the same ⇒ *page 54, General recommendations*.

- ▶ Fasten your safety belt and wear it properly. Also instruct your passengers to fasten their safety belts properly ⇒ *page 100*.

### What impairs driving safety?

Safe driving is directly related to the condition of the vehicle, the driver as well as the driver's ability to concentrate on the road without being distracted.

The driver is responsible for the safety of the vehicle and all of its occupants. If your ability to drive is impaired, safety risks for everybody in the vehicle increase and you also become a hazard to everyone else on the road ⇒ ⚠.

Therefore:

- ▶ Do not let yourself be distracted by passengers or by using a cellular telephone.
- ▶ NEVER drive when your driving ability is impaired (by medications, alcohol, drugs, etc.).
- ▶ Observe all traffic laws, rules of the road and speed limits and plain common sense.
- ▶ ALWAYS adjust your speed to road, traffic and weather conditions.
- ▶ Take frequent breaks on long trips. Do not drive for more than two hours at a stretch.
- ▶ Do NOT drive when you are tired, under pressure or when you are stressed.

### ⚠ WARNING

Impaired driving safety increases the risk of serious personal injury and death whenever a vehicle is being used.

## Proper occupant seating positions

### Proper seating position for the driver

The proper driver seating position is important for safe, relaxed driving.

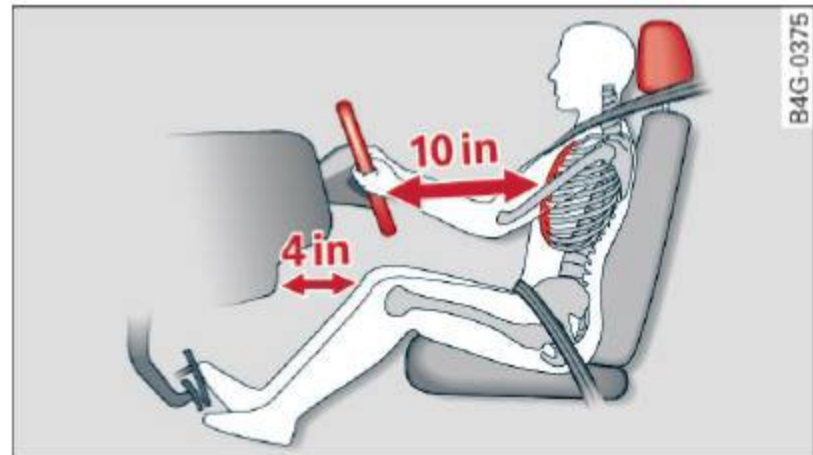

Fig. 91 The correct distance between driver and steering wheel

For your own safety and to reduce the risk of injury in the event of an accident, we recommend that you adjust the driver's seat to the following position:

- ▶ Adjust the driver's seat so that you can easily push the pedals all the way to the floor while keeping your knee(s) slightly bent ⇒ ⚠.
- ▶ Adjust the angle of the seatback so that it is in an upright position so that your back comes in full contact with it when you drive.
- ▶ Adjust the steering wheel so that there is a distance of at least 10 inches (25 cm) between the steering wheel and your breast bone ⇒ *fig. 91*. If not possible, see your authorized Audi dealership about adaptive equipment.
- ▶ Adjust the steering wheel so that the steering wheel and airbag cover points at your chest and not at your face.
- ▶ Grasp the top of the steering wheel with your elbow(s) slightly bent.
- ▶ Adjust the head restraint so the upper edge is as even as possible with the top of your head. If that is not possible, try to adjust the head restraint so that it is as close to this position as possible.
- ▶ Fasten and wear safety belts correctly ⇒ *page 104*.

- ▶ Always keep both feet in the footwell so that you are in control of the vehicle at all times.

For detailed information on how to adjust the driver's seat, see ⇒ *page 55*.



### WARNING

Drivers who are unbelted, out of position or too close to the airbag can be seriously injured by an airbag as it deploys. To help reduce the risk of serious personal injury:

- Always adjust the driver's seat and the steering wheel so that there are at least 10 inches (25 cm) between your breastbone and the steering wheel.
- Always adjust the driver's seat and the steering wheel so that there are at least 4 inches (10 cm) between the knees and the lower part of the instrument panel.
- Always hold the steering wheel on the outside of the steering wheel rim with your hands at the 9 o'clock and 3 o'clock positions to help reduce the risk of personal injury if the driver's airbag inflates.
- Never hold the steering wheel at the 12 o'clock position or with your hands at other positions inside the steering wheel rim or on the steering wheel hub. Holding the steering wheel the wrong way can cause serious injuries to the hands, arms and head if the driver's airbag inflates
- Pointing the steering wheel toward your face decreases the ability of the supplemental driver's airbag to protect you in a collision.
- Always sit in an upright position and never lean against or place any part of your body too close to the area where the airbags are located.
- Before driving, always adjust the front seats and head restraints properly and make sure that all passengers are properly restrained.
- Never adjust the seats while the vehicle is moving. Your seat may move unexpect-

edly and you could lose control of the vehicle.

- Never drive with the backrest reclined or tilted far back! The farther the backrests are tilted back, the greater the risk of injury due to incorrect positioning of the safety belt and improper seating position.
- Children must always ride in child seats ⇒ *page 130*. Special precautions apply when installing a child seat on the front passenger seat ⇒ *page 108*.

### Proper seating position for the front passenger

*The proper front passenger seating position is important for safe, relaxed driving.*

For your own safety and to reduce the risk of injury in the event of an accident, we recommend that you adjust the seat for the front passenger to the following position:

- ▶ Adjust the angle of the seatback so that it is in an upright position and your back comes in full contact with it whenever the vehicle is moving.
- ▶ Adjust the head restraint so that the upper edge is as even with the top of your head as possible but not lower than eye level and so that it is as close to the back of your head as possible ⇒ *page 94*.
- ▶ Keep both feet flat on the floor in front of the front passenger seat.
- ▶ Fasten and wear safety belts correctly ⇒ *page 104*.

For detailed information on how to adjust the front passenger's seat, see ⇒ *page 54*.



### WARNING

Front seat passengers who are unbelted, out of position or too close to the airbag can be seriously injured or killed by the airbag as it unfolds. To help reduce the risk of serious personal injury:

- Passengers must always sit in an upright position and never lean against or place any part of their body too close to the area where the airbags are located.
- Passengers who are unbelted, out of position or too close to the airbag can be seriously injured by an airbag as it unfolds with great force in the blink of an eye.
- Always make sure that there are at least 10 inches (25 cm) between the front passenger's breastbone and the instrument panel.
- Always make sure that there are at least 4 inches (10 cm) between the front passenger's knees and the lower part of the instrument panel.
- Each passenger must always sit on a seat of their own and properly fasten and wear the safety belt belonging to that seat.
- Before driving, always adjust the front passenger seat and head restraint properly.
- Always keep your feet on the floor in front of the seat. Never rest them on the seat, instrument panel, out of the window, etc. The airbag system and safety belt will not be able to protect you properly and can even increase the risk of injury in a crash.
- Never drive with the backrest reclined or tilted far back! The farther the backrests are tilted back, the greater the risk of injury due to incorrect positioning of the safety belt and improper seating position.
- Children must always ride in child seats ⇒ *page 130*. Special precautions apply when installing a child seat on the front passenger seat ⇒ *page 108*.

### Proper seating positions for passengers in rear seats

*Rear seat passengers must sit upright with both feet on the floor consistent with their physical size and be properly restrained whenever the vehicle is in use.*

To reduce the risk of injury caused by an incorrect seating position in the event of a sudden braking maneuver or an accident, your passengers on the rear bench seat must always observe the following:

- ▶ Make sure that the seatback is securely latched in the upright position ⇒ *page 59*.
- ▶ Keep both feet flat in the footwell in front of the rear seat.
- ▶ Fasten and wear safety belts properly ⇒ *page 104*.
- ▶ Make sure that children are always properly restrained in a child restraint that is appropriate for their size and age ⇒ *page 130*.



#### WARNING

Passengers who are improperly seated on the rear seat can be seriously injured in a crash.

- Each passenger must always sit on a seat of their own and properly fasten and wear the safety belt belonging to that seat.
- Safety belts only offer maximum protection when the seatback is securely latched in the upright position and the safety belts are properly positioned on the body. By not sitting upright, a rear seat passenger increases the risk of personal injury from improperly positioned safety belts!

### Proper adjustment of head restraints

Correctly adjusted head restraints are an important part of your vehicle's occupant restraint system and can help to reduce the risk of injuries in accident situations.

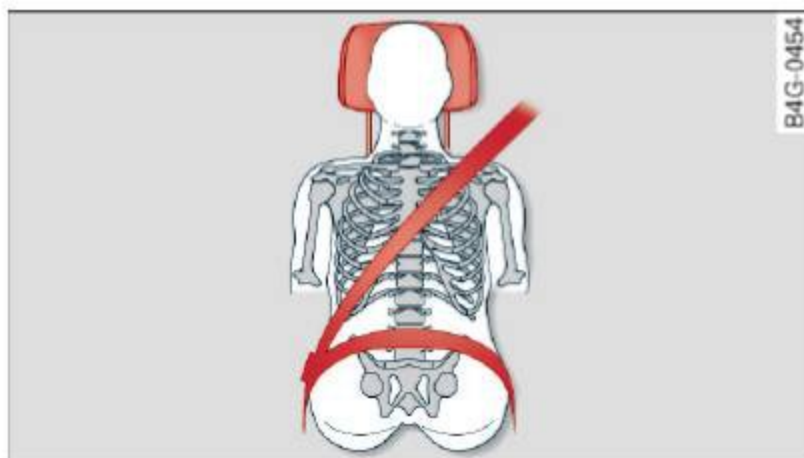

Fig. 92 Head restraint: viewed from the front

The head restraints must be correctly adjusted to achieve the best protection.

- ▶ For adjustable head restraints: adjust the head restraint so the upper edge is as even as possible with the top of your head. If that is not possible, try to adjust the head restraint so that it is as close to this position as possible ⇒ *fig. 92*.

Adjusting head restraints ⇒ *page 57*.

### WARNING

Driving without head restraints or with head restraints that are not properly adjusted increases the risk of serious or fatal neck injury dramatically. To help reduce the risk of injury:

- Always drive with the head restraints in place and properly adjusted.
- Every person in the vehicle must have a properly adjusted head restraint.
- Always make sure each person in the vehicle properly adjusts their head restraint. Each head restraint must be adjusted according to occupants' size so that the upper edge is as even with the top of the person's head, but no lower than eye level and so it is as close to the back of to the head as possible.
- Never attempt to adjust head restraint while driving. If you have driven off and

must adjust the driver headrest for any reason, first stop the vehicle safely before attempting to adjust the head restraint.

- Children must always be properly restrained in a child restraint that is appropriate for their age and size ⇒ *page 130*.

### Examples of improper seating positions

The occupant restraint system can only reduce the risk of injury if vehicle occupants are properly seated.

Improper seating positions can cause serious injury or death. Safety belts can only work when they are properly positioned on the body. Improper seating positions reduce the effectiveness of safety belts and will even increase the risk of injury and death by moving the safety belt to critical areas of the body. Improper seating positions also increase the risk of serious injury and death when an airbag deploys and strikes an occupant who is not in the proper seating position. A driver is responsible for the safety of all vehicle occupants and especially for children. Therefore:

- ▶ Never allow anyone to assume an incorrect seating position when the vehicle is being used ⇒ .

The following bullets list only some sample positions that will increase the risk of serious injury and death. Our hope is that these examples will make you more aware of seating positions that are dangerous.

### Therefore, whenever the vehicle is moving:

- never stand up in the vehicle
- never stand on the seats
- never kneel on the seats
- never ride with the seatback reclined
- never lie down on the rear seat
- never lean up against the instrument panel
- never sit on the edge of the seat
- never sit sideways
- never lean out the window

- never put your feet out the window
- never put your feet on the instrument panel
- never rest your feet on the seat cushion or back of the seat
- never ride in the footwell
- never ride in the cargo area

### WARNING

Improper seating positions increase the risk of serious personal injury and death whenever a vehicle is being used.

- Always make sure that all vehicle occupants stay in a proper seating position and are properly restrained whenever the vehicle is being used.

## Driver and passenger side footwell

### Important safety instructions

### WARNING

Always make sure that the knee airbag can inflate without interference. Objects between yourself and the airbag can increase the risk of injury in an accident by interfering with the way the airbag deploys or by being pushed into you as the airbag deploys.

- No persons (children) or animals should ride in the footwell in front of the passenger seat. If the airbag deploys, this can result in serious or fatal injuries.
- No objects of any kind should be carried in the footwell area in front of the driver's or passenger's seat. Bulky objects (shopping bags, for example) can hamper or prevent proper deployment of the airbag. Small objects can be thrown through the vehicle if the airbag deploys and injure you or your passengers.

## Pedal area

### Pedals

*The pedals must always be free to move and must never be interfered with by a floor mat or any other object.*

Make sure that all pedals move freely without interference and that nothing prevents them from returning to their original positions.

Only use floor mats that leave the pedal area free and can be secured with floor mat fasteners.

If a brake circuit fails, increased brake pedal travel is required to bring the vehicle to a full stop.

### WARNING

Pedals that cannot move freely can cause loss of vehicle control and increase the risk of serious injury.

- Never place any objects in the driver's footwell. An object could get into the pedal area and interfere with pedal function. In case of sudden braking or an accident, you would not be able to brake or accelerate!
- Always make sure that nothing can fall or move into the driver's footwell.

### Floor mats on the driver side

*Always use floor mats that can be securely attached to the floor mat fasteners and do not interfere with the free movement of the pedals.*

- ▶ Make sure that the floor mats are properly secured and cannot move and interfere with the pedals ⇒ .

Use only floor mats that leave the pedal area unobstructed and that are firmly secured so that they cannot slip out of position. You can obtain suitable floor mats from your authorized Audi Dealer.

Floor mat fasteners are installed in your Audi. ▶

Floor mats used in your vehicle must be attached to these fasteners. Properly securing the floor mats will prevent them from sliding into positions that could interfere with the pedals or impair safe operation of your vehicle in other ways.

**! WARNING**

Pedals that cannot move freely can result in a loss of vehicle control and increase the risk of serious personal injury.

- Always make sure that floor mats are properly secured.
- Never place or install floor mats or other floor coverings in the vehicle that cannot be properly secured in place to prevent them from slipping and interfering with the pedals or the ability to control the vehicle.
- Never place or install floor mats or other floor coverings on top of already installed floor mats. Additional floor mats and other coverings will reduce the size of the pedal area and interfere with the pedals.
- Always properly reinstall and secure floor mats that have been taken out for cleaning.
- Always make sure that objects cannot fall into the driver footwell while the vehicle is moving. Objects can become trapped under the brake pedal and accelerator pedal causing a loss of vehicle control.

## Stowing luggage

### Loading the luggage compartment

All luggage and other objects must be properly stowed and secured in the luggage compartment.

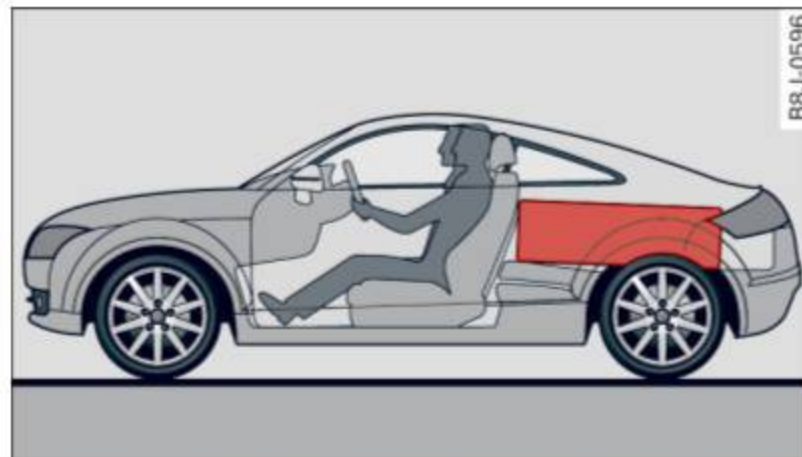

**Fig. 93** Safe load positioning: heavy cargo positioned as far forward as possible.

Loose items in the luggage compartment can shift suddenly, changing vehicle handling characteristics. Loose items can also increase the risk of serious personal injury in a sudden vehicle maneuver or in a collision.

- ▶ Distribute the load evenly in the luggage compartment.
- ▶ Always place and properly secure heavy items in the luggage compartment as far forward as possible ⇒ *fig. 93*.
- ▶ Secure luggage using the tie-downs provided ⇒ *page 59*.
- ▶ Make sure that the rear seatback is securely latched in place.

**! WARNING**

Improperly stored luggage or other items can fly through the vehicle causing serious personal injury in the event of hard braking or an accident. To help reduce the risk of serious personal injury:

- Always put objects, for example, luggage or other heavy items in the luggage compartment.
- Always secure objects in the luggage compartment using the tie-down eyelets and suitable straps.

**! WARNING**

Heavy loads will influence the way your vehicle handles. To help reduce the risk of a loss of control leading to serious personal injury:

- Always keep in mind when transporting heavy objects, that a change in the center of gravity can also cause changes in vehicle handling:
  - Always distribute the load as evenly as possible.
  - Place heavy objects as far forward in the luggage compartment as possible.
- Never exceed the Gross Axle Weight Rating or the Gross Vehicle Weight Rating specified on the safety compliance sticker on the left door jamb. Exceeding permissible weight standards can cause the vehicle to slide and handle differently.
- Please observe information on safe driving ⇒ *page 90*.

**! WARNING**

To help prevent poisonous exhaust gas from being drawn into the vehicle, always keep the rear lid closed while driving.

- Never transport objects larger than those fitting completely into the luggage area because the rear lid cannot be fully closed.
- If you absolutely must drive with the rear lid open, observe the following notes to reduce the risk of poisoning:
  - Close all windows,
  - Open all air outlets in the instrument panel,
  - Switch off the air recirculation,
  - Set the fresh air fan to the highest speed.

**! WARNING**

Always make sure that the doors, all windows and the rear lid are securely closed and locked to reduce the risk of injury when the vehicle is not being used.

- After closing the rear lid, always make sure that it is properly closed and locked.
- Never leave your vehicle unattended especially with the rear lid left open. A child could crawl into the vehicle through the luggage compartment and close the rear lid becoming trapped and unable to get out. Being trapped in a vehicle can lead to serious personal injury.
- Never let children play in or around the vehicle.
- Never let passengers ride in the luggage compartment. Vehicle occupants must always be properly restrained in one of the vehicle's seating positions.

**i Tips**

- Air circulation helps to reduce window fogging. Stale air escapes to the outside through vents in the trim panel, on the left side of the luggage compartment. Be sure to keep these slots free and open.
- The tire pressure must correspond to the load. The tire pressure is shown on the tire pressure label. The tire pressure label is located on the driver's side B-pillar. The tire pressure label lists the recommended cold tire inflation pressures for the vehicle at its maximum capacity weight and the tires that were on your vehicle at the time it was manufactured. For recommended tire pressures for normal load conditions, please see chapter ⇒ *page 200*.

**Tie-downs**

*The luggage compartment is equipped with four tie-downs to secure luggage and other items.*

Use the tie-downs to secure your cargo properly ⇒ *page 96, Loading the luggage compartment*.

In a collision, the laws of physics mean that even smaller items that are loose in the vehicle will become heavy missiles that can cause

serious injury. Items in the vehicle possess energy which vary with vehicle speed and the weight of the item. Vehicle speed is the most significant factor.

For example, in a frontal collision at a speed of 30 mph (48 km/h), the forces acting on a 10-lb (4.5 kg) object are about 20 times the normal weight of the item. This means that the weight of the item would suddenly be about 200 lbs. (90 kg). You can imagine the injuries that a 200 lbs. (90 kg) item flying freely through the passenger compartment could cause in a collision like this.

### **WARNING**

Weak, damaged or improper straps used to secure items to tie-downs can fail during hard braking or in a collision and cause serious personal injury.

- Always use suitable mounting straps and properly secure items to the tie-downs in the luggage compartment to help prevent items from shifting or flying forward as dangerous missiles.
- When the rear seat backrest is folded down, always use suitable mounting straps and properly secure items to the tie-downs in the luggage compartment to help prevent items from flying forward as dangerous missiles into the passenger compartment.
- Never attach a child safety seat tether strap to a tie-down.

## Reporting Safety Defects

### Applicable to U.S.A.

If you believe that your vehicle has a defect which could cause a crash or could cause injury or death, you should immediately inform the National Highway Traffic Safety Administration

(NHTSA) in addition to notifying Audi of America, Inc.

If NHTSA receives similar complaints, it may open an investigation, and if it finds that a safety defect exists in a group of vehicles, it may order a recall and remedy campaign. However, NHTSA cannot become involved in individual problems between you, your dealer, or Audi of America, Inc.

To contact NHTSA, you may call the Vehicle Safety Hotline toll-free at:

Tel.: 1-888-327-4236 (TTY:  
1-800-424-9153) or  
1-800-424-9393

or you may write to:

Administrator  
NHTSA  
1200 New Jersey Avenue, SE  
Washington, D.C. 20590

You can also obtain other information about motor vehicle safety from:

<http://www.safercar.gov>

### Applicable to Canada

If you live in Canada and you believe that your vehicle has a

defect that could cause a crash, injury or death, you should immediately inform Transport Canada, Defect Investigations and Recalls. You should also notify Volkswagen Group Canada, Inc.

Canadian customers who wish to report a safety-related defect to Transport Canada, Defect Investigations and Recalls, may either call Transport Canada toll-free at:

Tel.: 1-800-333-0510 or  
Tel.: 1-819-994-3328 (Ottawa region and from other countries)

TTY for hearing impaired: Tel.:  
1-888-675-6863

or contact Transport Canada by mail at:

Transport Canada  
Motor Vehicle Safety Investigations Laboratory  
80 Noel Street  
Gatineau, QC  
J8Z 0A1

For additional road safety information, please visit the Road Safety website at:

<http://www.tc.gc.ca/eng/roadsafety/menu.htm>

## Safety belts

### General notes

#### Always wear safety belts!

*Wearing safety belts correctly saves lives!*

This chapter explains why safety belts are necessary, how they work and how to adjust and wear them correctly.

- ▶ Read all the information that follows and heed all of the instructions and WARNINGS.

#### WARNING

Not wearing safety belts or wearing them improperly increases the risk of serious personal injury and death.

- Safety belts are the single most effective means available to reduce the risk of serious injury and death in automobile accidents. For your protection and that of your passengers, always correctly wear safety belts when the vehicle is moving.
- Pregnant women, injured, or physically impaired persons must also use safety belts. Like all vehicle occupants, they are more likely to be seriously injured if they do not wear safety belts. The best way to protect a fetus is to protect the mother - throughout the entire pregnancy.

#### Number of seats

Your Audi TT Coupe has two seating positions in the front and two height-limited seating positions in the rear. Each seating position has a safety belt. The rear seat area in your Audi TT Coupe does not have enough room for passengers of all sizes. For reasons of safety, no person taller than 4'11" (1.5 meters) should ever ride in the rear seat area.

#### WARNING

Not wearing safety belts or wearing them improperly increases the risk of serious personal injury and death.

- Never strap more than one person, including small children, into any belt. It is especially dangerous to place a safety belt over a child sitting on your lap.
- Never let more people ride in the vehicle than there are safety belts available.
- Be sure everyone riding in the vehicle is properly restrained with a separate safety belt or child restraint.
- Persons taller than 4'11" (1.5 m) as well as children in booster seats who are too close to the rear window and roof can suffer severe head and neck injuries when the rear lid is closed or in a crash.
- The minimum clearance between the passenger's heads and the rear window must never - under any circumstances - be less than 1 inch (2.5 cm.) when the passengers sit fully upright.
- Always make sure that rear seat passengers cannot be struck when the rear lid is closed.

#### Safety belt warning light

*Your vehicle has a warning system for the driver and front seat passenger to remind you about the importance of buckling-up.*



**Fig. 94** Safety belt warning light in the instrument cluster - enlarged

#### Before driving off, always:

- ▶ Fasten your safety belt and make sure you wear it properly.
- ▶ Make sure that your passengers also buckle up and properly wear their safety belts.
- ▶ Protect children with a child restraint system appropriate for the size and age.

The warning light  in the instrument cluster lights up when the ignition is switched on as a reminder to fasten the safety belts. In addition, you will hear a warning tone for a certain period of time.

**Fasten your safety belt and make sure that your passengers also properly put on their safety belts.**

### WARNING

- Safety belts are the single most effective means available to reduce the risk of serious injury and death in automobile accidents. For your protection and that of your passengers, always correctly wear safety belts when the vehicle is moving.
- Failure to pay attention to the warning light that come on, could lead to personal injury.

## Why safety belts?

### Frontal collisions and the law of physics

*Frontal crashes create very strong forces for people riding in vehicles.*

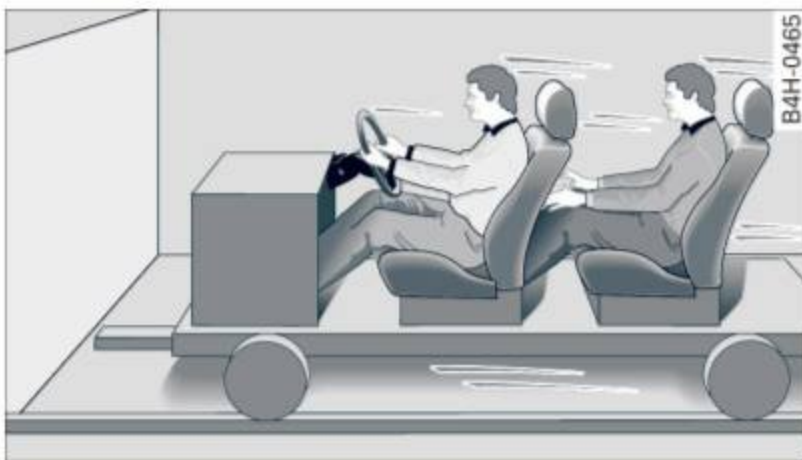

**Fig. 95** Unbelted occupants in a vehicle heading for a wall



**Fig. 96** The vehicle crashes into the wall.

The physical principles are simple. Both the vehicle and the passengers possess energy which varies with vehicle speed and body weight. Engineers call this energy “kinetic energy.”

The higher the speed of the vehicle and the greater the vehicle's weight, the more energy that has to be “absorbed” in the crash.

Vehicle speed is the most significant factor. If the speed doubles from 15 to 30 mph (25 to 50 km/h), the energy increases 4 times!

Because the occupants in this vehicle are not using safety belts  $\Rightarrow$  *fig. 95*, they will keep moving at the same speed the vehicle was moving just before the crash, until something stops them - here, the wall  $\Rightarrow$  *fig. 96*.

The same principles apply to people sitting in a vehicle that is involved in a frontal collision. Even at city speeds of 20 to 30 mph (30 to 50 km/h), the forces acting on the body can reach one ton (2,000 lbs, or 1,000 kg) or more. At higher speeds, these forces are even greater.

People who do not use safety belts are also not attached to their vehicle. In a frontal collision they will also keep moving forward at the speed their vehicle was travelling just before the crash. Of course, the laws of physics don't just apply to frontal collisions, they determine what happens in all kinds of accidents and collisions.

### What happens to occupants not wearing safety belts?

*In crashes unbelted occupants cannot stop themselves from flying forward and being injured or killed. Always wear your safety belts!*



**Fig. 97** A driver not wearing a safety belt is violently thrown forward



**Fig. 98** A rear passenger not wearing a safety belt will fly forward and strike the driver

Unbelted occupants are not able to resist the tremendous forces of impact by holding tight or bracing themselves. Without the benefit of safety restraint systems, the unrestrained occupant will slam violently into the steering wheel, instrument panel, windshield, or whatever else is in the way ⇒ *fig. 97*. This impact with the vehicle interior has all the energy they had just before the crash.

Never rely on airbags alone for protection. Even when they deploy, airbags provide only additional protection. Airbags are not supposed to deploy in all kinds of accidents. Although your Audi is equipped with airbags, all vehicle occupants, including the driver, must wear safety belts correctly in order to minimize the risk of severe injury or death in a crash.

Remember too, that airbags will deploy only once and that your safety belts are always

there to offer protection in those accidents in which airbags are not supposed to deploy or when they have already deployed. Unbelted occupants can also be thrown out of the vehicle where even more severe or fatal injuries can occur.

It is also important for the rear passengers to wear safety belts correctly. Unbelted passengers in the rear seats endanger not only themselves but also the driver and other passengers ⇒ *fig. 98*. In a frontal collision they will be thrown forward violently, where they can hit and injure the driver and/or front seat passenger.

### Safety belts protect

*People think it's possible to use the hands to brace the body in a minor collision. It's simply not true!*



**Fig. 99** Driver is properly restrained in a sudden braking maneuver.

Safety belts used properly can make a big difference. Safety belts help to keep passengers in their seats, gradually reduce energy levels applied to the body in an accident, and help prevent the uncontrolled movement that can cause serious injuries. In addition, safety belts reduce the danger of being thrown out of the vehicle.

Safety belts attach passengers to the car and give them the benefit of being slowed down more gently or “softly” through the “give” in the safety belts, crush zones and other safety features engineered into today's vehicles. By “absorbing” the kinetic energy over a longer period of time, the safety belts make the

forces on the body more “tolerable” and less likely to cause injury.

Although these examples are based on a frontal collision, safety belts can also substantially reduce the risk of injury in other kinds of crashes. So, whether you're on a long trip or just going to the corner store, always buckle up and make sure others do, too. Accident statistics show that vehicle occupants properly wearing safety belts have a lower risk of being injured and a much better chance of surviving an accident. Properly using safety belts also greatly increases the ability of the supplemental airbags to do their job in a collision. For this reason, wearing a safety belt is legally required in most countries including much of the United States and Canada.

Although your Audi is equipped with airbags, you still have to wear the safety belts provided. Front airbags, for example, are activated only in some frontal collisions. The front airbags are not activated in all frontal collisions, in side and rear collisions, in roll overs or in cases where there is not enough deceleration through impact to the front of the vehicle. The same goes for the other airbag systems in your Audi. So, always wear your safety belt and make sure everybody in your vehicle is properly restrained!

### Important safety instructions about safety belts

*Safety belts must always be properly positioned across the strongest bones of your body.*

- ▶ Always wear safety belts as illustrated and described in this chapter.
- ▶ Make sure that your safety belts are always ready for use and are not damaged.

#### WARNING

Not wearing safety belts or wearing them improperly increases the risk of serious personal injury and death. Safety belts can work only when used correctly.

- Always fasten your safety belts correctly before driving off and make sure all passengers are properly restrained.
- For maximum protection, safety belts must always be positioned correctly on the body.
- Never strap more than one person, including small children, into any single safety belt.
- Never place a safety belt over a child sitting on your lap.
- Always keep feet in the footwell in front of the seat while the vehicle is being driven.
- Never let any person ride with feet on the instrument panel or sticking out the window or on the seat.
- Never remove a safety belt while the vehicle is moving. Doing so will increase your risk of being injured or killed.
- Never wear belts twisted.
- Never wear belts over rigid or breakable objects in or on your clothing, such as eye glasses, pens, keys, etc., as these may cause injury.
- Never wear the shoulder part of the belt under your arm or otherwise out of position.
- Several layers of heavy clothing may interfere with correct positioning of belts and reduce their effectiveness.
- Always keep belt buckles free of anything that may prevent the buckle from latching securely.
- Never use comfort clips or devices that create slack in the shoulder belt. However, special clips may be required for the correct use of some child restraint systems.
- Never allow safety belts to become damaged by being caught in door or seat hardware.
- Torn or frayed safety belts can tear and damaged belt hardware can break in an accident. Inspect belts regularly. If webbing, bindings, buckles, or retractors are

damaged, have belts replaced by an authorized Audi dealer or qualified workshop.

- Safety belts that have been worn and loaded in an accident must be replaced with the correct replacement safety belt by an authorized Audi dealer or qualified workshop. Replacement may be necessary even if damage cannot be clearly seen. Anchorages that were loaded must also be inspected.
- Never remove, modify, disassemble, or try to repair the safety belts yourself.
- Always keep the belts clean. Dirty belts may not work properly and can impair the function of the inertia reel  
⇒ *page 174, Safety belts.*

## Safety belts

### Fastening safety belts

*Seat first - everybody buckle up!*



**Fig. 100** Belt buckle and tongue on the driver's seat

To provide maximum protection, safety belts must always be positioned correctly on the wearer's body.

- ▶ Adjust the front seat and head restraint properly ⇒ *page 54, General recommendations.*
- ▶ Hold the belt by the tongue and pull it evenly across the chest and pelvis ⇒ .
- ▶ Insert the tongue into the correct buckle of your seat until you hear it latch securely ⇒ *fig. 100.*
- ▶ Pull on the belt to make sure that it is securely latched in the buckle.

### Automatic safety belt retractors

Every safety belt is equipped with an automatic belt retractor on the shoulder belt. This feature locks the belt when the belt is pulled out fast, during hard braking and in an accident. The belt may also lock when you drive up or down a steep hill or through a sharp curve. During normal driving the belt lets you move freely.

### Safety belt pretensioners

The safety belts on the front seats are equipped with a belt pretensioner that helps to tighten the safety belt and remove slack when the pretensioner is activated. The function of the pretensioner is monitored by a warning light ⇒ *page 15.*

### Switchable locking feature

Every safety belt except the one on the driver seat is equipped with a switchable locking feature that **must** be used when the safety belt is used to attach a child seat. Be sure to read the important information about this feature ⇒ *page 140.*

### WARNING

Improperly positioned safety belts can cause serious injury in an accident

⇒ *page 105, Safety belt position.*

- Safety belts offer optimum protection only when the seatback is upright and belts are properly positioned on the body.
- Never attach the safety belt to the buckle for another seat. Attaching the belt to the wrong buckle will reduce safety belt effectiveness and can cause serious personal injury.
- A passenger who is not properly restrained can be seriously injured by the safety belt itself when it moves from the stronger parts of the body into critical areas like the abdomen.
- Always lock the convertible locking retractor when you are securing a child seat in the vehicle ⇒ *page 142.*

## Safety belt position

Correct belt position is the key to getting maximum protection from safety belts.

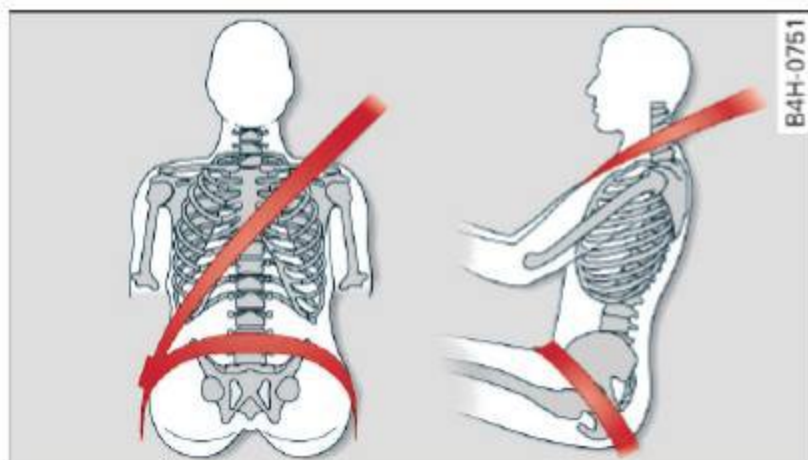

Fig. 101 Safety belt position

Standard features on your vehicle help you adjust the position of the safety belt to match your body size.

- height-adjustable front seats.

### WARNING

Improperly positioned safety belts can cause serious personal injury in an accident.

- The shoulder belt should lie as close to the center of the collar bone as possible and should fit well on the body. Hold the belt above the latch tongue and pull it evenly across the chest so that it sits as low as possible on the pelvis and there is no pressure on the abdomen. The belt should always fit snugly ⇒ *fig. 101*. Pull on the belt to tighten if necessary.
- The lap belt portion of the safety belt must be positioned as low as possible across pelvis and never over the abdomen. Make sure the belt lies flat and snug ⇒ *fig. 101*. Pull on the belt to tighten if necessary.
- A loose-fitting safety belt can cause serious injuries by shifting its position on your body from the strong bones to more vulnerable, soft tissue and cause serious injury.
- Always read and heed all WARNINGS and other important information ⇒ *page 103*.

## Pregnant women must also be properly restrained

The best way to protect the fetus is to make sure that expectant mothers always wear safety belts correctly - throughout the pregnancy.



Fig. 102 Safety belt position during pregnancy

To provide maximum protection, safety belts must always be positioned correctly on the wearer's body ⇒ *page 105*.

- ▶ Adjust the front seat and head restraint correctly ⇒ *page 54, General recommendations*.
- ▶ Make sure the seatback of the rear seat bench is in upright position and securely latched in place before using the belt.
- ▶ Hold the belt by the tongue and pull it evenly across the chest and pelvis ⇒ *fig. 102*, ⇒ .
- ▶ Insert the tongue into the correct buckle of your seat until you hear it latch securely ⇒ *page 104, fig. 100*.
- ▶ Pull on the belt to make sure that it is securely latched in the buckle.

### WARNING

Improperly positioned safety belts can cause serious personal injury in an accident.

- Expectant mothers must always wear the lap portion of the safety belt as low as possible across the pelvis and below the rounding of the abdomen.
- Always read and heed all WARNINGS and other important information ⇒  in *Fastening safety belts on page 104*.

### Unfastening safety belts

Unbuckle the safety belt with the red release button only after the vehicle has stopped.



Fig. 103 Releasing the tongue from the buckle

- ▶ Push the red release button on the buckle ⇒ *fig. 103*. The belt tongue will spring out of the buckle ⇒ .
- ▶ Let the belt wind up on the retractor as you guide the belt tongue to its stowed position.

### WARNING

Never unfasten safety belt while the vehicle is moving. Doing so will increase your risk of being injured or killed.

### Improperly worn safety belts

Incorrectly positioned safety belts can cause severe injuries.

Wearing safety belts improperly can cause serious injury or death. Safety belts can only work when they are correctly positioned on the body. Improper seating positions reduce the effectiveness of safety belts and will even increase the risk of injury and death by moving the safety belt to critical areas of the body. Improper seating positions also increase the risk of serious injury and death when an airbag deploys and strikes an occupant who is not in the correct seating position. A driver is responsible for the safety of all vehicle occupants and especially for children. Therefore:

- ▶ Never permit anyone to assume an incorrect sitting position in the vehicle while traveling ⇒ .

### WARNING

Improperly worn safety belts increase the risk of serious personal injury and death whenever a vehicle is being used.

- Always make sure that all vehicle occupants are correctly restrained and stay in a correct seating position whenever the vehicle is being used.
- Always read and heed all WARNINGS and other important information ⇒ *page 103*.

## Safety belt pretensioners

### How safety belt pretensioners work

In front and side collisions above a particular severity, safety belts in use are tensioned automatically.

The safety belts for the front seating positions are equipped with safety belt pretensioners. The system is activated by sensors in front and side collisions of great severity. This tightens the belt and takes up belt slack ⇒  in *Service and disposal of safety belt pretensioner on page 107*. Taking up the slack helps to reduce forward occupant movement during a collision.

### Tips

- The safety belt pretensioner can only be activated once.
  - In minor frontal and side collisions, in rear-end collisions, in a rollover and in accidents involving very little impact force, the safety belt pretensioner are not activated.
  - When the safety belt pretensioner is activated, a fine dust is released. This is normal and is not caused by a fire in the vehicle.
  - The relevant safety requirements must be observed when the vehicle or components of the system are scrapped. A qualified dealership is familiar with

these regulations and will be pleased to pass on the information to you.

- Be sure to observe all safety, environmental and other regulations if the vehicle or individual parts of the system, particularly the safety belt or airbag, are to be disposed. We recommend you have your authorized Audi dealer perform this service for you.

### Service and disposal of safety belt pretensioner

The safety belt pretensioners are parts of the safety belts on your Audi. Installing, removing, servicing or repairing of belt pretensioners can damage the safety belt system and prevent it from working correctly in a collision.

There are some important things you have to know to make sure that the effectiveness of the system will not be impaired and that discarded components do not cause injury or pollute the environment.

#### WARNING

Improper care, servicing and repair procedures can increase the risk of personal injury and death by preventing a safety belt pretensioner from activating when needed or activating it unexpectedly:

- The belt pretensioner system can be activated only once. If belt pretensioners have been activated, the system must be replaced.
- Never repair, adjust, or change any parts of the safety belt system.
- Safety belt systems including safety belt pretensioners cannot be repaired. Special procedures are required for removal, installation and disposal of this system.
- For any work on the safety belt system, we strongly recommend that you see your authorized Audi dealer or qualified technician who has an Audi approved repair manual, training and special equipment necessary.



#### For the sake of the environment

Undeployed airbag modules and pretensioners might be classified as Perchlorate Material -special handling may apply, see [www.dtsc.ca.gov/hazardouswaste/perchlorate](http://www.dtsc.ca.gov/hazardouswaste/perchlorate). When the vehicle or parts of the restraint system including airbag modules safety belts with pretensioners are scrapped, all applicable laws and regulations must be observed. Your authorized Audi dealer is familiar with these requirements and we recommend that you have your dealer perform this service for you.

## Airbag system

### Important things to know

#### Importance of wearing safety belts and sitting properly

*Airbags are only supplemental restraints. For airbags to do their job, occupants must always properly wear their safety belts and be in a proper seating position.*

For your safety and the safety of your passengers, before driving off, always:

- ▶ Adjust the driver's seat and steering wheel properly ⇒ *page 91*,
- ▶ Adjust the front passenger's seat properly ⇒ *page 55*,
- ▶ Wear safety belts properly ⇒ *page 103*,
- ▶ Always properly use the proper child restraint to protect children ⇒ *page 130*.

In a collision airbags must inflate within the blink of an eye and with considerable force. The supplemental airbags can cause injuries if the driver or the front seat passenger are not seated properly. Therefore in order to help the airbag to do its job, it is important, both as a driver and as a passenger to sit properly at all times.

By keeping room between your body and the steering wheel and the front of the passenger compartment, the airbag can inflate fully and completely and provide supplemental protection in certain frontal collisions ⇒ *page 91*, *Proper occupant seating positions*. For details on the operation of the seat adjustment controls ⇒ *page 55* and ⇒ *page 56*.

It's especially important that children are properly restrained ⇒ *page 130*.

There is a lot that the driver and the passengers can and must do to help the individual safety features installed in your Audi work together as a system.

Proper seating position is important so that the front airbag on the driver side can do its job. If you have a physical impairment or con-

dition that prevents you from sitting properly on the driver seat with the safety belt properly fastened and reaching the pedals, or if you have concerns with regard to the function or operation of the Advanced Airbag System, please contact your authorized Audi dealer or qualified workshop, or call Audi Customer Relations at 1-800-822-2834 for possible modifications to your vehicle.

When the airbag system deploys, a gas generator will fill the airbags, break open the padded covers, and inflate between the steering wheel and the driver and between the instrument panel and the front passenger. The airbags will deflate immediately after deployment so that the front occupants can see through the windshield again without interruption.

All of this takes place in the blink of an eye, so fast that many people don't even realize that the airbags have deployed. The airbags also inflate with a great deal of force and nothing should be in their way when they deploy. Front airbags in combination with properly worn safety belts slow down and limit the occupant's forward movement. Together they help to prevent the driver and front seat passenger from hitting parts of the inside the vehicle while reducing the forces acting on the occupant during the crash. In this way they help to reduce the risk of injury to the head and upper body in the crash. Airbags do not protect the arms or the lower parts of the body.

Both front airbags will not inflate in all frontal collisions. The triggering of the airbag system depends on the vehicle deceleration rate caused by the collision and registered by the electronic control unit. If this rate is below the reference value programmed into the control unit, the airbags will not be triggered, even though the car may be badly damaged as a result of the collision. Vehicle damage, repair costs or even the lack of vehicle damage is not necessarily an indication of whether an airbag should inflate or not. ►

It is not possible to define a range of vehicle speeds that will cover every possible kind and angle of impact that will always trigger the airbags, since the circumstances will vary considerably between one collision and another. Important factors include, for example, the nature (hard or soft) of the object which the car hits, the angle of impact, vehicle speed, etc. The front airbags will also not inflate in side or rear collisions, or in roll-overs.

**Always remember:** Airbags will deploy only once, and only in certain kinds of collisions. Your safety belts are always there to offer protection in those situations in which airbags are not supposed to deploy, or when they have already deployed; for example, when your vehicle strikes or is struck by another after the first collision.

This is just one of the reasons why an airbag is a supplementary restraint and is not a substitute for a safety belt. The airbag system works most effectively when used with the safety belts. Therefore, always properly wear your safety belts ⇒ *page 100*.

### WARNING

- Sitting too close to the steering wheel or instrument panel will decrease the effectiveness of the airbags and will increase the risk of personal injury in a collision.
- Never sit closer than 10 inches (25 cm) to the steering wheel or instrument panel.
  - If you cannot sit more than 10 inches (25 cm) from the steering wheel, investigate whether adaptive equipment may be available to help you reach the pedals and increase your seating distance from the steering wheel.
  - If you are unrestrained, leaning forward, sitting sideways or out of position in any way, your risk of injury is much higher.
  - You will also receive serious injuries and could even be killed if you are up against the airbag or too close to it when it inflates - even with an Advanced Airbag.

- To reduce the risk of injury when an airbag inflates, always wear safety belts properly ⇒ *page 104, Safety belts*.
- Always make certain that children age 12 or younger always ride in the rear seat. If children are not properly restrained, they may be severely injured or killed when an airbag inflates.
- Never let children ride unrestrained or improperly restrained in the vehicle. Adjust the front seats properly.
- Never ride with the backrest reclined.
- Always sit as far as possible from the steering wheel or the instrument panel ⇒ *page 91, Proper occupant seating positions*.
- Always sit upright with your back against the backrest of your seat.
- Never place your feet on the instrument panel or on the seat. Always keep both feet on the floor in front of the seat to help prevent serious injuries to the legs and hips if the airbag inflates.
- Never recline the front passenger's seat to transport objects. Items can also move into the area of the side airbag or the front airbag during braking or in a sudden maneuver. Objects near the airbags can become projectiles and cause injury when an airbag inflates.

### WARNING

- Airbags that have deployed in a crash must be replaced.
- Use only original equipment airbags approved by Audi and installed by a trained technician who has the necessary tools and diagnostic equipment to properly replace any airbag in your vehicle and assure system effectiveness in a crash.
  - Never permit salvaged or recycled airbags to be installed in your vehicle.

### Child restraints on the front seat – some important things to know

- ▶ Be sure to read the important information and heed the WARNINGS for important details about children and Advanced Airbags ⇒ *page 130*.

Even though your vehicle is equipped with an Advanced Airbag System, make certain that all children, especially those 12 years and younger, always ride in the back seat properly restrained for their age and size. The airbag on the passenger side makes the front seat a potentially dangerous place for a child to ride. The front seat is not the safest place for a child in a forward-facing child safety seat. It can be a very dangerous place for an infant or a child in a rearward-facing seat.

The Advanced Airbag System in your vehicle has been certified to comply with the Requirements of United States Federal Motor Vehicle Safety Standard 208 as applicable at the time your vehicle was manufactured.

The Standard requires the front airbag on the passenger side to be turned off (“suppressed”) if a child up to about one year of age restrained in one of the rear-facing or forward-facing infant restraints listed in Federal Motor Vehicle Safety Standard 208 with which the Advanced Airbag System in your vehicle was certified has been installed on the front passenger seat. For a listing of the child restraints that were used to certify compliance with the US Safety Standard ⇒ *page 132*.

The **PASSENGER AIR BAG OFF** light in the instrument panel tells you when the front Advanced Airbag on the passenger side has been turned off by the electronic control unit.

Each time you turn on the ignition, the **PASSENGER AIR BAG OFF** light will come on for a few seconds and:

- will stay on if the front passenger seat is not occupied,
- will stay on if there is a small child or child restraint on the front passenger seat,

- will go off if the front passenger seat is occupied by an adult as registered by the weight-sensing mat ⇒ *page 119, Monitoring the Advanced Airbag System*.

The **PASSENGER AIR BAG OFF** light comes on when the control unit detects a total weight on the front passenger seat that requires the front airbag to be turned off.

If the total weight on the front passenger seat is more than that of a typical 1 year-old child but less than the weight of a small adult, the front airbag on the passenger side can deploy (the **PASSENGER AIR BAG OFF** light does not come on). If the **PASSENGER AIR BAG OFF** light does not come on, the front airbag on the passenger side has not been turned off by the electronic control unit and can deploy if the control unit senses an impact that meets the conditions stored in its memory.

#### For example, the airbag may deploy if:

- a small child that is heavier than a typical 1 year-old child is on the front passenger seat (regardless of whether the child is in one of the child safety seats listed ⇒ *page 132*), or
- a child who has outgrown child restraints is on the front passenger seat.

If the front passenger airbag is turned off, the **PASSENGER AIR BAG OFF** light comes on in the instrument panel and stays on.

The front airbag on the passenger side may *not* deploy (the **PASSENGER AIR BAG OFF** light does not illuminate and stay lit) even if a small adult or teenager, or a passenger who is not sitting upright with their back against a non-reclined backrest with their feet on the vehicle floor in front of the seat is on the front passenger seat ⇒ *page 91, Proper seating position for the driver*.

If the front passenger airbag deploys, the Federal Standard requires the airbag to meet the “low risk” deployment criteria to reduce the risk of injury through interaction with the airbag. “Low risk” deployment occurs in those crashes that take place at lower decelerations ►

as defined in the electronic control unit  
 ⇒ *page 119, PASSENGER AIR BAG OFF light.*

Always remember, a child safety seat or infant carrier installed on the front seat may be struck and knocked out of position by the rapidly inflating passenger's airbag in a frontal collision. The airbag could greatly reduce the effectiveness of the child restraint and even seriously injure the child during inflation.

For this reason, and because the back seat is the safest place for children - when properly restrained according to their age and size - we strongly recommend that children always sit in the back seat ⇒ *page 130, Child Safety.*

### WARNING

A child in a rearward-facing child safety seat installed on the front passenger seat will be seriously injured and can be killed if the front airbag inflates - even with an Advanced Airbag System.

- The inflating airbag will hit the child safety seat or infant carrier with great force and will smash the child safety seat and child against the backrest, door or roof.
- Always install rear-facing child safety seats on the rear seat.
- If you must install a rearward facing child safety seat on the front passenger seat because of exceptional circumstances and the **PASSENGER AIR BAG OFF** light does not come on and stay on, immediately install the rear-facing child safety seat in a rear seating position and have the airbag system inspected by your Audi dealer.
- Forward-facing child safety seats installed on the front passenger's seat may interfere with the deployment of the airbag and cause serious personal injury to the child.

### WARNING

If, in exceptional circumstances, you must install a forward-facing child restraint on the front passenger's seat:

- Always make sure the forward-facing seat has been designed and certified by its manufacturer for use on a front seat with a passenger front and side airbag.
- Never put the forward-facing child restraint up against or very near the instrument panel.
- Always move the passenger seat into its rearmost position in the seat's fore and aft adjustment range, as far away from the airbag as possible before installing the forward-facing child restraint. The backrest must be adjusted to an upright position.
- Make sure that the **PASSENGER AIR BAG OFF** light comes on and stays on all the time whenever the ignition is switched on.

### WARNING

To reduce the risk of serious injury, make sure that the **PASSENGER AIR BAG OFF** light will be displayed whenever a child restraint is installed on the front passenger seat and the ignition is switched on.

- If the **PASSENGER AIR BAG OFF** light does not stay on, perform the checks described ⇒ *page 119, Monitoring the Advanced Airbag System.*
- Take the child restraint off the front passenger seat and install it properly at one of the rear seat positions if the **PASSENGER AIR BAG OFF** light does not stay on.
- Have the airbag system inspected by your Audi dealer immediately.
- Always carefully follow instructions from child restraint manufacturers when installing child restraints.

### WARNING

If, in exceptional circumstances, you must install a forward or rearward-facing child restraint on the front passenger's seat:

- Improper installation of child restraints can reduce their effectiveness or even prevent them from providing any protection.

- An improperly installed child restraint can interfere with the airbag as it deploys and seriously injure or even kill the child – even with an Advanced Airbag System.
- Always carefully follow the manufacturer's instructions provided with the child safety seat or carrier.
- Never place additional items on the seat that can increase the total weight registered by the weight-sensing mat and can cause injury in a crash.

## Front airbags

### Description of front airbags

*The airbag system can provide supplemental protection to properly restrained front seat occupants.*



**Fig. 104** Location of driver airbag: in steering wheel



**Fig. 105** Location of front passenger's airbag: in the instrument panel

Your vehicle is equipped with an “Advanced Airbag System” in compliance with United States Federal Motor Vehicle Safety Standard (FMVSS) 208 as applicable at the time your vehicle was manufactured. The safety belts for the front seats have “pretensioners” that help to take slack out of the belt system. The

pretensioners are also activated by the electronic control unit for the airbag system.

The front safety belts also have load limiters to help reduce the forces applied to the body in a crash.

The airbag for the driver is in the steering wheel hub ⇒ *fig. 104* and the airbag for the front passenger is in the instrument panel ⇒ *fig. 105*. The general location of the airbags is marked “AIRBAG”.

There is a lot you need to know about the airbags in your vehicle. We urge you to read the detailed information about airbags, safety belts and child safety in this and the other chapters that make up the owner's literature. Please be sure to heed the WARNINGS - they are extremely important for your safety and the safety of your passengers, especially infants and small children.

### WARNING

- Never rely on airbags alone for protection.
- Even when they deploy, airbags provide only supplemental protection.
  - Airbags work most effectively when used with properly worn safety belts.
  - Therefore, always wear your safety belts and make sure that everybody in your vehicle is properly restrained.

### WARNING

- A person on the front passenger seat, especially infants and small children, will receive serious injuries and can even be killed by being too close to the airbag when it inflates.
- Although the Advanced Airbag System in your vehicle is designed to turn off the front passenger airbag if an infant or a small child is on the front passenger seat, nobody can absolutely guarantee that deployment under these special conditions is impossible in all conceivable situations that may happen during the useful life of your vehicle.

- The Advanced Airbag System can deploy in accordance with the “low risk” option under the U.S. Federal Standard if a child that is heavier than the typical one-year old child is on the front passenger seat and the other conditions for airbag deployment are met.
- Accident statistics have shown that children are generally safer in the rear seat area than in the front seating position.
- For their own safety, all children, especially 12 years and younger, should always ride in the back properly restrained for their age and size.

### Advanced front airbag system

Your vehicle is equipped with a front Advanced Airbag System in compliance with United States Federal Motor Vehicle Safety Standard 208 as applicable at the time your vehicle was manufactured.

The front Advanced Airbag System supplements the safety belts to provide additional protection for the driver's and front passenger's heads and upper bodies in frontal crashes. The airbags inflate only in frontal impacts when the vehicle deceleration is high enough.

The front Advanced Airbag System for the front seat occupants is not a substitute for your safety belts. Rather, it is part of the overall occupant restraint system in your vehicle. Always remember that the airbag system can only help to protect you, if you are sitting upright, wearing your safety belt and wearing it properly. This is why you and your passengers must always be properly restrained, not just because the law requires you to be.

The Advanced Airbag System in your vehicle has been certified to meet the “low risk” requirements for 3 and 6 year-old children on the passenger side and very small adults on the driver side. The low risk deployment criteria are intended to help reduce the risk of injury through interaction with the front airbag that can occur, for example, by being too

close to the steering wheel and instrument panel when the airbag inflates.

In addition, the system has been certified to comply with the “suppression” requirements of the Safety Standard, to turn off the front airbag for infants 12 months old and younger who are restrained on the front passenger seat in child restraints that are listed in the Standard ⇒ *page 132, Child restraints and Advanced Airbags.*

“Suppression” requires the front airbag on the passenger side to be turned off if:

- a child up to about one year of age is restrained on the front passenger seat in one of the rear-facing or forward-facing infant restraints listed in Federal Motor Vehicle Safety Standard 208 with which the Advanced Airbag System in your vehicle was certified. For a listing of the child restraints that were used to certify your vehicle's compliance with the US Safety Standard ⇒ *page 132,*
- weight less than a threshold level stored in the control unit is detected on the front passenger seat.

When a person is detected on the front passenger seat, weighing more than the total weight of a child that is about 1 year old restrained in one of the rear-facing or forward-facing infant restraints (listed in Federal Motor Vehicle Safety Standard 208 with which the Advanced Airbag System in your vehicle was certified), the front airbag on the passenger side may or may not deploy.

The **PASSENGER AIR BAG OFF** light comes on when the electronic control unit detects a total weight on the front passenger seat that requires the front airbag to be turned off. If the **PASSENGER AIR BAG OFF** light does not come on, the front airbag on the passenger side has not been turned off by the control unit and can deploy if the control unit senses an impact that meets the conditions stored in its memory.

If the total weight on the front passenger seat is more than that of a typical 1 year-old, ►

but less than the weight of a small adult, the front airbag on the passenger side may deploy (the **PASSENGER AIR BAG OFF** light does not come on).

**For example, the airbag may deploy if:**

- a small child that is heavier than a typical 1 year-old child is on the front passenger seat (regardless of whether the child is in one of the child safety seats listed ⇒ *page 132*),
- a child who has outgrown child restraints is on the front passenger seat.

If the front passenger airbag is turned off, the **PASSENGER AIR BAG OFF** light in the center of the instrument panel will come on and stay on.

The front airbag on the passenger side may *not* deploy (the **PASSENGER AIR BAG OFF** light does not illuminate and stay lit) if:

- a small adult or teenager is on the front passenger seat
- a passenger who is not sitting upright with their back against a non-reclined backrest with their feet on the vehicle floor in front of the seat is on the front passenger seat.

If the front passenger airbag deploys, the Federal Standard requires the airbag to meet the “low risk” deployment criteria to help reduce the risk of injury through interaction with the airbag. “Low risk” deployment occurs in those crashes that take place at lower decelerations as defined in the electronic control unit ⇒ *page 119*.

**Always remember:** Even though your vehicle is equipped with Advanced Airbags, the safest place for children is properly restrained on the back seat. Please be sure to read the important information in the sections that follow and be sure to heed all of the WARNINGS.

 **WARNING**

- To reduce the risk of injury when an airbag inflates, always wear safety belts properly.
- If you are unrestrained, leaning forward, sitting sideways or out of position in any way, your risk of injury is much higher.

- You will also receive serious injuries and could even be killed if you are up against the airbag or too close to it when it inflates - even with an Advanced Airbag ⇒ *page 108*.

 **WARNING**

A child in a rearward-facing child safety seat installed on the front passenger seat will be seriously injured and can be killed if the front airbag inflates - even with an Advanced Airbag System.

- Although the Advanced Airbag System in your vehicle is designed to turn off the front airbag when a rearward-facing child restraint has been installed on the front passenger seat, nobody can absolutely guarantee that deployment is impossible in all conceivable situations that may happen during the useful life of your vehicle.
- The inflating airbag will hit the child safety seat or infant carrier with great force and will smash the child safety seat and child against the backrest, door, or roof.
- Always install rearward-facing child restraints in the back seat.
- If you must install a rearward facing child safety seat on the front passenger seat because of exceptional circumstances and the **PASSENGER AIR BAG OFF** light does not come on and stay on, immediately install the rear-facing child safety seat in a rear seating position and have the airbag system inspected by your Audi dealer.

 **WARNING**

If, in exceptional circumstances, you must install a forward-facing child restraint on the front passenger's seat:

- Always make sure the forward-facing seat has been designed and certified by its manufacturer for use on a front seat with a passenger front and side airbag.

- Never put the forward-facing child restraint up against or very near the instrument panel.
- Always move the passenger seat into its rearmost position in the seat's fore and aft adjustment range, as far away from the airbag as possible, before installing the forward-facing child restraint. The backrest must be adjusted to an upright position.
- Make sure that the **PASSENGER AIR BAG OFF** light comes on and stays on all the time whenever the ignition is switched on.

### Advanced Airbag System components

The front passenger seat in your vehicle has a lot of very important parts of the Advanced Airbag System in it. These parts include the weight-sensing mat, sensors, wiring, brackets, and more. The function of the system in the front passenger seat is checked by the electronic control unit when the ignition is on. The control unit monitors the Advanced Airbag System and turns the airbag indicator light on when a malfunction in the system components is detected. The function of the airbag indicator light is described in greater detail below. Because the front passenger seat contains important parts of the Advanced Airbag System, you must take care to prevent it from being damaged. Damage to the seat may prevent the Advanced Airbag for the front passenger seat from doing its job in a crash.

#### The front Advanced Airbag System consists of the following:

- Crash sensors in the front of the vehicle that measure vehicle acceleration/deceleration to provide information to the Advanced Airbag System about the severity of the crash.
- An electronic control unit, with integrated crash sensors for front and side impacts. The control unit “decides” whether to fire the front airbags based on the information received from the crash sensors. The control

- unit also “decides” whether the safety belt pretensioners should be activated.
- An Advanced Airbag with gas generator for the driver inside the steering wheel hub.
- An Advanced Airbag with gas generator inside the instrument panel for the front passenger.
- A weight-sensing mat under the upholstery padding of the front passenger seat cushion that measures the total weight on the seat. The information registered is sent continuously to the electronic control unit to regulate deployment of the front Advanced Airbag on the passenger side.
- An airbag monitoring system and indicator light in the instrument cluster ⇒ *page 119*.
- The **PASSENGER AIR BAG OFF** light comes on and stays on in the center of the instrument panel ⇒ *page 119, fig. 107* and tells you when the front Advanced Airbag on the passenger side has been turned off.
- A sensor below the safety belt latch for the front seat passenger to measure the tension on the safety belt. The tension on the safety belt and the weight registered by the weight-sensing mat help the control unit “decide” whether the front airbag for the front passenger seat should be turned off or not ⇒ *page 110, Child restraints on the front seat – some important things to know*.
- A sensor in the safety belt latch for the driver and for the front seat passenger that senses whether that safety belt is latched or not and transmits this information to the electronic control unit.

#### WARNING

Damage to the front passenger seat can prevent the front airbag from working properly.

- Improper repair or disassembly of the front passenger and driver seat will prevent the Advanced Airbag System from functioning properly.
- Repairs to the front passenger seat must be performed by qualified and properly trained workshop personnel.

- Never remove the front passenger or driver seat from the vehicle.
- Never remove the upholstery from the front passenger seat.
- Never disassemble or remove parts from the seat or disconnect wires from it.
- Never carry sharp objects in your pockets or place them on the seat. If the weight-sensing mat in the passenger seat is punctured it cannot work properly.
- Never carry things on your lap or carry objects on the passenger seat. Such items can increase the weight registered by the weight-sensing mat and send the wrong information to the airbag control unit.
- Never store items under the front passenger seat. Parts of the Advanced Airbag System under the passenger seat could be damaged, preventing them and the airbag system from working properly.
- Never place seat covers or replacement upholstery that have not been specifically approved by Audi on the front seats.
- Seat covers can prevent the Advanced Airbag System from recognizing child restraints or occupants on the front passenger seat and prevent the side airbag in the seat backrest from deploying properly.
- Never use cushions, pillows, blankets or similar items on the front passenger seat. The additional padding will prevent the weight-sensing mat in the seat from accurately registering the child restraint or person on the seat and prevent the Advanced Airbag System from functioning properly.
- If you must use a child restraint on the front passenger seat and the child restraint manufacturer's instructions require the use of a towel, foam cushion or something else to properly position the child restraint, make certain that the **PASSENGER AIR BAG OFF** light comes on and stays on whenever the child re-

straint is installed on the front passenger seat.

- If the **PASSENGER AIR BAG OFF** light does not come on and stay on, immediately install child restraint in a rear seating position and have the airbag system inspected by your Audi dealer.

### How the Advanced Airbag System components work together

The front Advanced Airbag System and the side airbags supplement the protection offered by the front three-point safety belts with pretensioners and load limiters and the adjustable head restraints to help reduce the risk of injury in a wide range of accident and crash situations. Be sure to read the important information about safety and heed the **WARNINGS** in this chapter.

Deployment of the Advanced Airbag System and the activation of the safety belt pretensioners depend on the deceleration measured by the crash sensors and registered by the electronic control unit. Crash severity depends on speed and deceleration as well as the mass and stiffness of the vehicle or object involved in the crash.

When the electronic control unit registers a low severity crash and the safety belt is being used, the airbag will not deploy. If the safety belt is not being used, the first stage deploys, followed by the second stage after a much later time in the crash sequence.

If the electronic control unit registers a crash of medium severity, the first stage of the airbag deploys followed by the second stage at a much later time in the crash sequence - regardless of whether the safety belt is being used or not. In higher severity crashes as registered by the electronic control unit, both the first and second stages deploy almost at the same time.

On the passenger side, regardless of safety belt use, the airbag will be turned off if the weight on the passenger seat is less than the amount programmed in the electronic control ►

unit. The front airbag on the passenger side will also be turned off if one of the child safety seats that has been certified under Federal Motor Vehicle Safety Standard 208 has been recognized on the seat. The **PASSENGER AIR BAG OFF** light comes on and stays on to tell you when the front Advanced Airbag on the passenger side has been turned off  
 ⇒ page 110, *Child restraints on the front seat – some important things to know.*

### WARNING

To reduce the risk of injury when an airbag inflates, always wear safety belts properly.

- If you are unrestrained, leaning forward, sitting sideways or out of position in any way, your risk of injury is much higher.
- You will also receive serious injuries and could even be killed if you are up against the airbag or too close to it when it inflates - even with an Advanced Airbag  
 ⇒ page 108.

### More important things to know about front airbags



Fig. 106 Inflated front airbags

Safety belts are important to help keep front seat occupants in the proper seated position so that airbags can unfold properly and provide supplemental protection in a frontal collision.

The front airbags are designed to provide additional protection for the chest and face of the driver and the front seat passenger when:

- safety belts are worn properly,

- the seats have been positioned so that the occupant is properly seated as far as possible from the airbag,
- and the head restraints have been properly adjusted.

Because airbags inflate in the blink of an eye with great force, things you have on your lap or have placed on the seat could become dangerous projectiles, and be pushed into you if the airbag inflates.

When an airbag deploys, fine dust is released. This is normal and is not caused by a fire in the vehicle. This dust is made up mostly of a powder used to lubricate the airbags as they deploy. It could irritate skin.

It is important to remember that while the supplemental airbag system is designed to reduce the likelihood of serious injuries, other injuries, for example swelling, bruising and minor abrasions, can also happen when airbags inflate. Airbags do not protect the arms or the lower parts of the body. Front airbags only supplement the three point safety belts in some frontal collisions in which the vehicle deceleration is high enough to deploy the airbags.

#### Front airbags will not deploy:

- if the ignition is switched off when a crash occurs,
- in side collisions,
- in rear-end collisions,
- in rollovers,
- when the crash deceleration measured by the airbag system is less than the minimum threshold needed for airbag deployment as registered by the electronic control unit.

#### The front passenger airbag will also not deploy:

- when the front passenger seat is not occupied,
- when the weight on the front passenger seat as sensed by the Advanced Airbag System indicates that the front airbag on the passenger side has to be turned off by the

electronic control unit (the **PASSENGER AIR BAG OFF** light comes on and stays on).

 **WARNING**

Sitting in the wrong position can increase the risk of serious injury in crashes.

- To reduce the risk of injury when the airbags inflate, the driver and passengers must always sit in an upright position, must not lean against or place any part of their body too close to the area where the airbags are located.
- Occupants who are unbelted, out of position or too close to the airbag can be seriously injured by an airbag as it unfolds with great force in the blink of an eye  
⇒ page 110.

 **WARNING**

A child in a rearward-facing child safety seat installed on the front passenger seat will be seriously injured and can be killed if the front airbag inflates - even with an Advanced Airbag System.

- The inflating airbag will hit the child safety seat or infant carrier with great force and will smash the child safety seat and child against the backrest, center arm rest, door or roof.
- Always install rear-facing child safety seats on the rear seat.
- If you must install a rearward facing child safety seat on the front passenger seat because of exceptional circumstances and the **PASSENGER AIR BAG OFF** light does not come on and stay on, immediately install the rear-facing child safety seat in a rear seating position and have the airbag system inspected by your Audi dealer.

 **WARNING**

Objects between you and the airbag will increase the risk of injury in a crash by interfering with the way the airbag unfolds or by being pushed into you as the airbag inflates.

- Never hold things in your hands or on your lap when the vehicle is in use.
- Never transport items on or in the area of the front passenger seat. Objects could move into the area of the front airbags during braking or other sudden maneuver and become dangerous projectiles that can cause serious personal injury if the airbags inflate.
- Never place or attach accessories or other objects (such as cup holders, telephone brackets, large, heavy or bulky objects) on the doors, over or near the area marked "AIRBAG" on the steering wheel, instrument panel, seat backrests or between those areas and yourself. These objects could cause injury in a crash, especially when the airbags inflate.
- Never recline the front passenger's seat to transport objects. Items can also move into the area of the side airbag or the front airbag during braking or in a sudden maneuver. Objects near the airbags can become projectiles and cause injury, particularly when the seat is reclined.
- Never tilt the front passenger seat backrest forward when the vehicle is moving. An inflating airbag will force the backrest backward and can injure rear seat occupants.

 **WARNING**

The fine dust created when airbags deploy can cause breathing problems for people with a history of asthma or other breathing conditions.

- To reduce the risk of breathing problems, those with asthma or other respiratory conditions should get fresh air right away by getting out of the vehicle or opening windows or doors.
- If you are in a collision in which airbags deploy, wash your hands and face with mild soap and water before eating.
- Be careful not to get the dust into your eyes, or into any cuts or scratches.

- If the residue should get into your eyes, flush them with water.

## Monitoring the Advanced Airbag System

### **AIR BAG** Airbag monitoring indicator light

Two separate indicators monitor the function of the Advanced Airbag System: the airbag monitoring indicator light and the **PASSENGER AIR BAG OFF** light.

The Advanced Airbag System (including the electronic control unit, sensor circuits and system wiring) is monitored continuously to make sure that it is functioning properly whenever the ignition is on. Each time you turn on the ignition, the airbag monitoring indicator light **AIR BAG** will come on for a few seconds (self diagnostics).

**The system must be inspected when the indicator light **AIR BAG**:**

- does not come on when the ignition is switched on,
- does not go out a few seconds after you have switched on the ignition, or
- comes on while driving.

If an airbag system malfunction is detected, the indicator light will first start flashing to catch the driver's attention and then stay on continuously to serve as a constant reminder to have the system inspected immediately.

If a malfunction occurs that turns the front airbag on the passenger side off, the **PASSENGER AIR BAG OFF** light will come on and stay on whenever the ignition is on.

### **!** WARNING

An airbag system that is not functioning properly cannot provide supplemental protection in a frontal crash.

- If the airbag indicator light comes on, it means that there may be something wrong with the Advanced Airbag System.

It is possible that the airbag will inflate when it is not supposed to, or will not inflate when it should.

- Have the airbag system inspected immediately by your Audi dealer.

### **PASSENGER AIR BAG OFF** light



**Fig. 107** Section from the instrument panel: **PASSENGER AIR BAG OFF** light

The **PASSENGER AIR BAG OFF** light is located in the center of the instrument panel  
⇒ *fig. 107*.

The **PASSENGER AIR BAG OFF** light will come on and stay on to tell you when the front Advanced Airbag on the passenger side has been turned off by the electronic control unit. Each time you turn on the ignition, the **PASSENGER AIR BAG OFF** light will flash for a few seconds and:

- will stay on if the front passenger seat is not occupied,
- will stay on if there is a small child or child restraint on the front passenger seat,
- will go out if the front passenger seat is occupied by an adult as registered by the weight-sensing mat.

The **PASSENGER AIR BAG OFF** light **must come on and stay on** if the ignition is on and

- a car bed has been installed on the front seat, or
- a rearward-facing child restraint has been installed on the front passenger seat, or
- a forward-facing child restraint has been installed on the front passenger seat, or

- the weight registered on the front passenger seat is equal to or less than the combined weight of a typical 1 year-old restrained in one of the rear-facing or forward-facing infant restraints listed in Federal Motor Vehicle Safety Standard 208 with which the Advanced Airbag System in your vehicle was certified.

If the front passenger seat is not occupied, the front airbag will not deploy, and the **PASSENGER AIR BAG OFF** light will stay on. Never install a rearward-facing child restraint on the front passenger seat, the safest place for a child in any kind of child restraint is at one of the seating positions on the rear seat  
 ⇒ *page 110, Child restraints on the front seat – some important things to know* and  
 ⇒ *page 130, Child Safety.*

**If the PASSENGER AIR BAG OFF light comes on** when one of the conditions listed above is met, be sure to check the light regularly to make certain that the **PASSENGER AIR BAG OFF** light stays on continuously whenever the ignition is on. If the **PASSENGER AIR BAG OFF** light does not appear and not stay on all the time, stop as soon as it is safe to do so and

- reactivate the system by turning the ignition off and then turning it on again;
- remove and reinstall the child restraint. Make sure that the child restraint is properly installed and that the safety belt for the front passenger seat has been correctly routed around the child restraint as described in the child restraint manufacturer's instructions;
- make sure that the convertible locking feature on the safety belt for the front passenger seat has been activated and that the safety belt has been pulled tight. The belt must not be loose or have loops of slack so that the sensor below the safety belt latch on the seat can do its job ⇒ *page 140.*
- make sure that things that may increase the weight of the child and child safety seat are not being transported on the front passenger seat;

- make sure that the safety belt tension sensor is not blocked. Shake the safety belt latch on the front passenger seat back and forth;
- If a strap or tether is being used to tie the child safety seat to the front passenger seat, make sure that it is not so tight that it causes the weight-sensing mat to measure more weight than is actually on the seat.

**If the PASSENGER AIR BAG OFF light still does not come on** and does not stay on continuously (when the ignition is switched on),

- take the child restraint off the front passenger seat and install it properly at one of the rear seat positions. Have the airbag system inspected by your Audi dealer immediately.
- move the child to a rear seat position and make sure that the child is properly restrained in a child restraint that is appropriate for its size and age.

The **PASSENGER AIR BAG OFF** light should NOT come on when the ignition is on and an adult is sitting in a proper seating position on the front passenger seat. If the **PASSENGER AIR BAG OFF** light comes on and stays on or flashes for about 5 seconds while driving, under these circumstances, make sure that:

- the adult on the front passenger seat is properly seated on the center of the seat cushion with his or her back up against the backrest and the backrest is not reclined  
 ⇒ *page 91, Proper occupant seating positions,*
- the adult is not taking weight off the seat by holding on to the passenger assist handle above the front passenger door,
- the safety belt is being properly worn and that there is not a lot of slack in the safety belt webbing,
- accessory seat covers or cushions or other things that may cause an incorrect reading or impression on the weight-sensing mat under the upholstery of the seat have been removed from the front passenger seat, ►

- a safety belt extender has not been left in the safety belt latch for the front passenger seat.

In addition to the **PASSENGER AIR BAG OFF** light in the center of the instrument panel, the message **PASSENGER AIR BAG OFF** or **PASSENGER AIR BAG ON** will briefly appear in the instrument cluster display. This is to inform the driver of the current front passenger airbag status.

### Important safety instructions on monitoring the Advanced Airbag System

#### WARNING

An airbag system that is not functioning properly cannot provide supplemental protection in a frontal crash.

- If the airbag indicator light comes on, it means that there may be something wrong with the Advanced Airbag System. It is possible that the airbag will inflate when it is not supposed to, or will not inflate when it should.
- Have the airbag system inspected immediately by your Audi dealer.

#### WARNING

If the front airbag inflates, a child without a child restraint, in a rearward-facing child safety seat or in a forward-facing child restraint that has not been properly installed will be seriously injured and can be killed.

- Even though your vehicle is equipped with an Advanced Airbag System, make certain that all children, especially 12 years and younger, always ride on the back seat properly restrained for their age and size.
- Always install forward or rear-facing child safety seats on the rear seat – even with an Advanced Airbag System.
- If you must install a rearward-facing child safety seat on the front passenger seat because of exceptional circumstances and the **PASSENGER AIR BAG OFF** light does not appear and stay on, imme-

diately install the rear-facing child safety seat in a rear seating position and have the airbag system inspected by your Audi dealer.

- A tight tether or other strap on a rearward-facing child restraint attached to the front passenger seat can put too much pressure on the weight-sensing mat in the seat and register more weight than is actually on the seat. The heavier weight registered can make the system work as though an adult were on the seat and deploy the Advanced Airbag when it must be suppressed causing serious or even fatal injury to the child.
- If, in exceptional circumstances, you must install a forward-facing child restraint on the front passenger seat, always move the seat into its rearmost position in the seat's fore and aft adjustment range, as far away from the airbag as possible. The backrest must be adjusted to an upright position. Make sure that the **PASSENGER AIR BAG OFF** light comes on and stays on all the time whenever the ignition is switched on.

#### WARNING

- If the **PASSENGER AIR BAG OFF** light does not go out when an adult is sitting on the front passenger seat after taking the steps described above, make sure the adult is properly seated and restrained at one of the rear seating positions.
- Have the airbag system inspected by your Audi dealer before transporting anyone on the front passenger seat.

#### Tips

If the weight-sensing mat in the front passenger seat detects an empty seat, the front airbag on the passenger side will be turned off, and **PASSENGER AIR BAG OFF** will stay on.

### Repair, care and disposal of the airbags

Parts of the airbag system are installed at many different places on your Audi. Installing, removing, servicing or repairing a part in an area of the vehicle can damage a part of an airbag system and prevent that system from working properly in a collision.

There are some important things you have to know to make sure that the effectiveness of the system will not be impaired and that discarded components do not cause injury or pollute the environment.

#### WARNING

Improper care, servicing and repair procedures can increase the risk of personal injury and death by preventing an airbag from deploying when needed or deploying an airbag unexpectedly:

- Never cover, obstruct, or change the steering wheel horn pad or airbag cover or the instrument panel or modify them in any way.
- Never attach any objects such as cup holders or telephone mountings to the surfaces covering the airbag units.
- For cleaning the horn pad or instrument panel, use only a soft, dry cloth or one moistened with plain water. Solvents or cleaners could damage the airbag cover or change the stiffness or strength of the material so that the airbag cannot deploy and protect properly.
- Never repair, adjust, or change any parts of the airbag system.
- All work on the steering wheel, instrument panel, front seats or electrical system (including the installation of audio equipment, cellular telephones and CB radios, etc.) must be performed by a qualified technician who has the training and special equipment necessary.
- For any work on the airbag system, we strongly recommend that you see your authorized Audi dealer or qualified workshop.

- Never modify the front bumper or parts of the vehicle body.
- Always make sure that the side airbag can inflate without interference:
  - Never install seat covers or replacement upholstery over the front seat-backs that have not been specifically approved by Audi.
  - Never use additional seat cushions that cover the areas where the side airbags inflate.
  - Damage to the original seat covers or to the seam in the area of the side airbag module must always be repaired immediately by an authorized Audi dealer.
- The airbag system can be activated only once. After an airbag has inflated, it must be replaced by an authorized Audi dealer or qualified technician who has the technical information, training and special equipment necessary.
- The airbag system can be deployed only once. After an airbag has been deployed, it must be replaced with new replacement parts designed and approved especially for your Audi model version. Replacement of complete airbag systems or airbag components must be performed by qualified workshops only. Make sure that any airbag service action is entered in your Audi Warranty & Maintenance booklet under *AIRBAG REPLACEMENT RECORD*.
- For safety reasons in severe accidents, the alternator and starter are separated from the vehicle battery with a pyrotechnic circuit interrupter.
  - Work on the pyrotechnic circuit interrupter must only be performed by a qualified dealer - risk of an accident!
  - If the vehicle or the circuit interrupter is scrapped, all applicable safety precautions must be followed.



### For the sake of the environment

Undeployed airbag modules and pretensioners might be classified as Perchlorate Material -special handling may apply, see [www.dtsc.ca.gov/hazardouswaste/perchlorate](http://www.dtsc.ca.gov/hazardouswaste/perchlorate). When the vehicle or parts of the restraint system including airbag modules and safety belts with pretensioners are scrapped, all applicable laws and regulations must be observed. Your authorized Audi dealer is familiar with these requirements and we recommend that you have your dealer perform this service for you.

### Other things that can affect Advanced Airbag performance

Changing the vehicle's suspension system can change the way that the Advanced Airbag System performs in a crash. For example, using tire-rim combinations not approved by Audi, lowering the vehicle, changing the stiffness of the suspension, including the springs, suspension struts, shock absorbers etc. can change the forces that are measured by the airbag sensors and sent to the electronic control unit. Some suspension changes can, for example, increase the force levels measured by the sensors and make the airbag system deploy in crashes in which it would not deploy if the changes had not been made. Other kinds of changes may reduce the force levels measured by the sensors and prevent the airbag from deploying when it should.

The sensors in the safety belt buckle for the driver and front passenger seat tell the electronic control module if the safety belt is latched or not. If the safety belt is being used, the front airbag will deploy at a slightly higher rate of vehicle deceleration than if the safety belt is not being used. Therefore, in a particular collision, it is possible that an airbag will not deploy at a seating position where the safety belt is being used but will inflate at the position where the safety belt is not being used. It is important that nothing interfere with the safety belt buckles so that the sen-

sors can send the correct information about safety belt use to the electronic control unit.



#### WARNING

Changing the vehicle's suspension including use of unapproved tire-rim combinations can change Advanced Airbag performance and increase the risk of serious personal injury in a crash.

- Never install suspension components that do not have the same performance characteristics as the components originally installed on your vehicle.
- Never use tire-rim combinations that have not been approved by Audi.



#### WARNING

Items stored between the safety belt buckle and the center console can cause the sensors in the buckle to send the wrong information to the electronic control module and prevent the Advanced Airbag System from working properly.

- Always make sure that nothing can interfere with the safety belt buckles and that they are not obstructed.

## Knee airbags

### Description of knee airbags

*The knee airbag system can provide supplemental protection to properly restrained front seat occupants.*

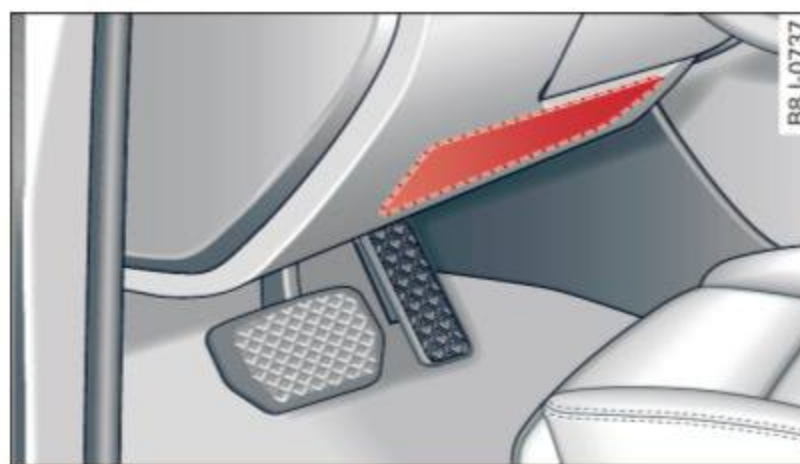

Fig. 108 Driver's airbag

The driver knee airbag is in the instrument panel underneath the steering wheel ⇒ *fig. 108*, the airbag for the passenger is at ▶

about the same height in the instrument panel underneath the glove compartment.

The knee airbag offers additional protection to the driver's and passenger's knees and upper and lower thigh areas and supplements the protection by the safety belts.

If the front airbags deploy, the knee airbags also deploy in frontal collisions when the deployment threshold stored in the control unit is met ⇒ *page 117, More important things to know about front airbags.*

In addition to their normal safety function, safety belts help keep the driver or front passenger in position in a frontal collision so that the airbags can provide supplemental protection.

The airbag system is not a substitute for your safety belt. Rather, it is part of the overall occupant restraint system in your vehicle. Always remember that the airbag system can only help to protect you if you are wearing your safety belt and wearing it properly. This is why you should always wear your safety belt, not just because the law requires you to do so ⇒ *page 100, General notes.*

The safety belt buckle for the driver and front seat passenger have switches that tell the airbag control module if the safety belt is being used or not. If the safety belt is being used, the knee airbag will deploy at a slightly higher rate of deceleration than if the belt is not being used. Therefore, in a particular collision, it is possible that an airbag will not deploy at a seating position where the safety belt is being used but will inflate at the position where the safety belt is not being used.

Remember too, airbags will deploy only once and only in certain kinds of accidents - your safety belts are always there to offer protection in those accidents in which airbags are not supposed to deploy or when they have already deployed, for example when your vehicle strikes or is struck by another after the first collision.

This is just one of the reasons why an airbag is not a substitute for the safety belt. The airbag system works most effectively when used with the safety belts. Therefore, always wear your safety belts correctly.

It is important to remember that while the supplemental knee airbag system is designed to reduce the likelihood of serious injuries, other injuries, for example, swelling, bruising, minor abrasions and friction burns can also occur when an airbag inflates.

#### **The knee airbag system basically consists of:**

- The electronic control module
- Two inflatable airbags (airbag and gas generator), one for the driver and one for the front passenger
- The airbag indicator light in the instrument panel

#### **The knee airbag system will not deploy:**

- when the ignition is turned off
- in frontal collisions when the deceleration measured by the control unit is too low
- in side collisions
- in rear-end collisions
- in rollovers
- in the event of a system malfunction (warning/indicator light is on) ⇒ *page 15.*

#### **WARNING**

- Safety belts and the airbag system can only provide protection when occupants are in the proper seating position ⇒ *page 117.*
- If the airbag indicator light comes when the vehicle is being used, have the system inspected immediately by your authorized Audi dealer.

## How knee airbags work

The risk of injury to the leg area can be reduced by fully inflated knee airbags.

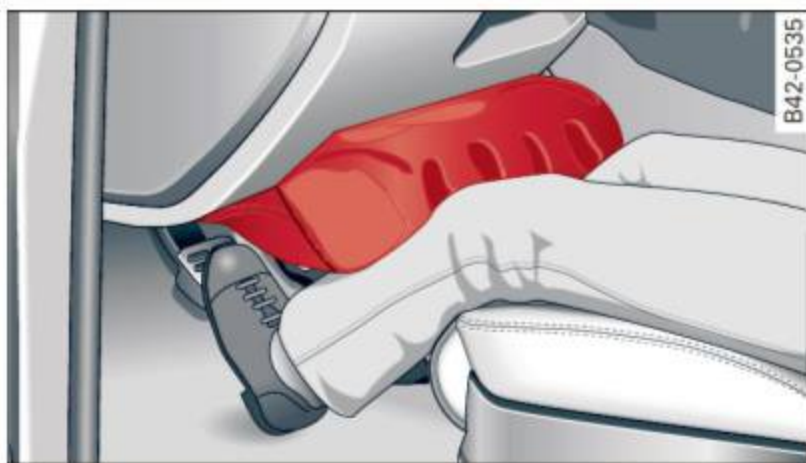

**Fig. 109** Inflated airbags protecting in a frontal collision

The knee airbag system has been designed so that the airbags for the driver and front passenger deploy in certain but not all frontal collisions.

If the front airbags deploy, the knee airbags also deploy in frontal collisions when the deployment threshold stored in the control unit is met.

When the system deploys, the airbags fill with a propellant gas, and inflate between the lower part of the instrument panel and the driver and the lower part of the instrument panel and the front passenger ⇒ *page 117, fig. 106.*

Although they are not a soft pillow, they can “cushion” the impact and in this way they can help to reduce the risk of injury to the lower extremities.

All of this takes place in the blink of an eye, so fast that many people don't even realize that the airbags have deployed. The airbags also inflate with a great deal of force and it is important for occupant safety that nothing should be in their way when they deploy.

Fully inflated airbags in combination with properly worn safety belts slow down and limit the occupant's forward movement and help to reduce the risk of injury.

## Important safety instructions on the knee airbag system

*Airbags are only supplemental restraints. Always wear safety belts correctly and ride in a proper seating position.*

There is a lot that you and your passengers must know and do to help the safety belts and airbags to provide supplemental protection.

### WARNING

An inflating knee airbag can cause serious injury. Wearing safety belts incorrectly and improper seating positions increase the risk of serious personal injury and death whenever a vehicle is being used.

- The knee airbag system cannot protect you properly if you are seated too close to any of the airbag locations. When adjusting their seat positions, it is important that both the driver and the front passenger keep their upper bodies and knees at the following minimum safe distances:
  - at least 10 inches (25 cm) between the chest and the steering wheel/instrument panel.
  - at least 4 inches (10 cm) between the knees and the lower part of the instrument panel.
- The risk of personal injury increases if you lean forward or to the side, or if the seat is improperly positioned and you are not wearing your safety belt. The risk increases even more should the airbag deploy.
- Always make sure that the knee airbag can inflate without interference. Objects between you and the airbag can increase the risk of injury in an accident by interfering with the way the airbag deploys or by being pushed into you as the airbag deploys.
  - Never let anybody, especially children or animals ride in the footwell in front

of the passenger seat. If the airbag deploys, this can result in serious or fatal injuries.

- Never carry objects of any kind in the footwell area in front of the driver's or passenger's seat. Bulky objects (shopping bags, for example) can interfere with or prevent proper deployment of the airbag. Small objects can be thrown through the vehicle if the airbag deploys and injure you or your passengers.
- Make sure there are no cracks, deep scratches or other damage in the area of the instrument panel where the knee airbags are located.
- If children are incorrectly seated, their risk of injury increases in a collision ⇒ *page 130, Child Safety.*

## Side airbags

### Description of side airbags

The airbag system can provide supplemental protection to properly restrained front seat occupants.

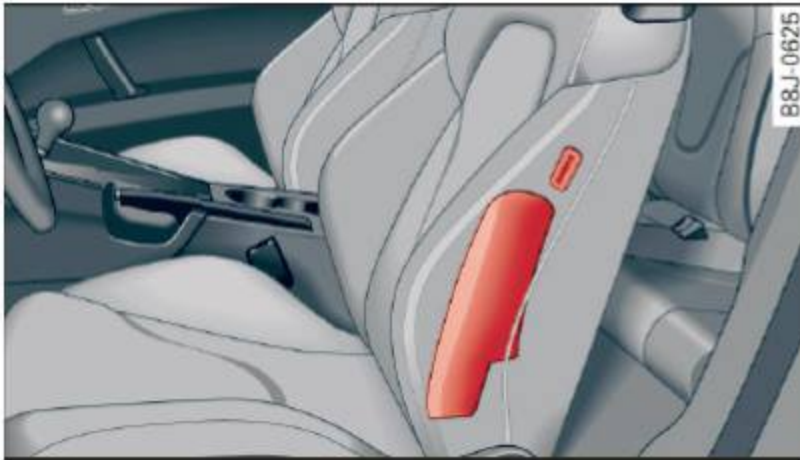

**Fig. 110** Side airbag location in the driver's seat

The side airbags are located in the sides of the front seat backrests ⇒ *fig. 110* facing the doors. They are identified by the word "AIR-BAG".

### The side airbag system basically consists of:

- the electronic control module and external side impact sensors
- the two side airbags located in the sides of the front backrests

- the airbag warning light in the instrument cluster.

The airbag system is monitored electronically to make certain that it is functioning properly at all times. Each time you turn on the ignition, the airbag system indicator light will come on for a few seconds (self diagnostics).

The side airbag system supplements the safety belts and can help to reduce the risk of injury to the driver's and front passenger's upper torso and head on the side of the vehicle that is struck in a side collision. The airbag deploys in side impacts and only when the vehicle acceleration registered by the control unit is high enough. If this rate is below the reference value programmed into the control unit, the side airbags will not be triggered, even though the car may be badly damaged as a result of the collision. It is not possible to define an airbag triggering range that will cover every possible angle of impact, since the circumstances will vary considerably between one collision and another. Important factors include, for example, the nature (hard or soft) of the impacting object, the angle of impact, vehicle speed, etc. ⇒ *page 128, Important safety instructions on the side airbag system.*

Aside from their normal safety function, safety belts work to help keep the driver or front passenger in position in the event of a side collision so that the side airbags can provide protection.

The airbag system is *not* a substitute for your safety belt. Rather, it is part of the overall occupant restraint system in your vehicle. Always remember that the side airbag system can only help to protect you if you are wearing your safety belt and wearing it properly. This is another reason why you should always wear your safety belts, not just because the law requires you to do so ⇒ *page 100, General notes.*

It is important to remember that while the supplemental side airbag system is designed to reduce the likelihood of serious injuries, other injuries, for example, swelling, bruising, ►

and minor abrasions can also be associated with deployed side airbags. Remember too, side airbags will deploy only once and only in certain kinds of accidents - your safety belts are always there to offer protection.

Vehicle damage, repair costs or even the lack of vehicle damage are not necessarily an indication of over-sensitive or failed airbag activation. In some collisions, both front and side airbags may inflate. Remember too, that airbags will deploy only once and only in certain kinds of collisions - your safety belts are always there to offer protection in those accidents in which airbags are not supposed to deploy or when they have already deployed.

#### The side airbag system will not deploy:

- when the ignition is turned off
- in side collisions when the acceleration measured by the sensor is too low
- in rear-end collisions
- in rollovers.

In some types of accidents the front airbags and side airbags may be triggered together.

#### WARNING

- Safety belts and the airbag system will only provide protection when occupants are in the proper seating position ⇒ *page 128*.
- If the airbag indicator light comes on when the vehicle is being used, have the system inspected immediately by your authorized Audi dealer. The airbag may not work properly when the vehicle acceleration in a side collision is high enough to activate the airbag.

#### How supplemental side airbags work

*Side airbags deploy instantly and can help reduce the risk of upper torso injuries for occupants who are properly restrained.*



Fig. 111 Inflated side airbags on left side of vehicle

When the system is triggered, the airbag is filled with propellant gas and breaks through a seam in the seat surface area marked "AIR-BAG". It expands between the side trim panel and the passenger. In order to help provide this additional protection, the side airbag must inflate within a fraction of a second at very high speed and with great force. The supplemental side airbag could injure you if your seating position is not proper or upright or if items are located in the area where the supplemental side airbag expands. This applies especially to children ⇒ *page 130, Child Safety*. Supplemental side airbags inflate between the occupant and the door panel on the side of the vehicle that is struck in certain side collision ⇒ *fig. 111*.

Although they are not a soft pillow, they can "cushion" the impact and in this way they can help to reduce the risk of injury to the upper part of the body.

A fine dust may develop when the airbag deploys. This is normal and does not mean there is a fire in the vehicle.

### Important safety instructions on the side airbag system

*Airbags are only supplemental restraints. Always properly wear safety belts and ride in a proper seating position.*

There is a lot that you and your passengers must know and act accordingly to help the safety belts and airbags do their job to provide supplemental protection.

#### WARNING

An inflating side airbag can cause serious or fatal injury. Improperly wearing safety belts and improper seating positions increase the risk of serious personal injury and death whenever a vehicle is being used.

- In order to reduce the risk of injury when the supplemental side airbag inflates:
  - Always sit in an upright position and never lean against the area where the supplemental side airbag is located.
  - Never let a child or anyone else rest their head against the side trim panel in the area where the supplemental side airbag inflates.
  - Always make sure that safety belts are worn correctly,
  - Do not let anyone sitting in the front seat put their hand or any other parts of their body out of the window.
- Always make sure that the side airbag can inflate without interference.
  - Never install seat covers or replacement upholstery over the front seat-backs that have not been specifically approved by Audi.
  - Never use additional seat cushions that cover the areas where the side airbags deploy.
  - Damage to the original seat covers or to the seam in the area of the side airbag module must always be repaired immediately by an authorized Audi dealer.

- Objects between you and the airbag can increase the risk of injury in an accident by interfering with the way the airbag unfolds or by being pushed into you as the airbag inflates.
  - Never place or attach accessories or other objects (such as cup holders, telephone brackets, or even large, bulky objects) on the doors, over or near the area marked “AIRBAG” on the seat backrests.
  - Such objects and accessories can become dangerous projectiles and cause injury when the supplemental side airbag deploys.
  - Never carry any objects or pets in the deployment space between them and the airbags or allow children or other passengers to travel in this position.
- Always use the built-in coat hooks only for lightweight clothing. Never leave any heavy or sharp-edged objects in the pockets that may interfere with side airbag deployment and can cause personal injury in an accident.
- Always prevent the side airbags from being damaged by heavy objects knocking against or hitting the sides of the seat-backs.
- The airbag system can only be triggered once. If the airbag has been triggered, the system must be replaced by an authorized Audi dealership.
- Damage (cracks, deep scratches etc.) to the original seat covers or to the seam in the area of the side airbag module must always be repaired immediately by an authorized Audi dealer.
- If children are seated improperly, their risk of injury increases in the case of an accident ⇒ *page 130, Child Safety*.
- Never attempt to modify any components of the airbag system in any way.
- In a side collision, side airbags will not function properly if sensors cannot correctly measure increasing air pressure inside the doors when air escapes through

larger, unclosed openings in the door panel.

- Never drive with interior door trim panels removed.
- Never drive when parts have been removed from the inside door panel and the openings they leave have not been properly closed.
- Never drive when loudspeakers in the doors have been removed unless the speaker holes have been properly closed.
- Always make certain that openings are covered or filled if additional speakers or other equipment is installed in the inside door panels.
- Always have work on the doors done by an authorized Audi dealer or qualified workshop.

## Child Safety

### Important things to know

#### Introduction

*The rear seat is generally the safest place in a collision.*

The physical principles of what happens when your vehicle is in a crash apply also to children ⇒ *page 102, What happens to occupants not wearing safety belts?*. But unlike adults and teenagers, their muscles and bones are not fully developed. In many respects children are at greater risk of serious injury in crashes than adults.

Because children's bodies are not fully developed, they require restraint systems especially designed for their size, weight, and body structure. Many countries and all states of the United States and provinces of Canada have laws requiring the use of approved child restraint systems for infants and small children.

In a frontal crash at a speed of 20-35 mph (30-56 km/h) the forces acting on a 13-pound (6 kg) infant will be more than 20 times the weight of the child. This means the weight of the child would suddenly be more than 260 pounds (120 kg). Under these conditions, only an appropriate child restraint properly used can reduce the risk of serious injury. Child restraints, like adult safety belts, must be used properly to be effective. Used improperly, they can increase the risk of serious injury in an accident.

Consult the child safety seat manufacturer's instructions in order to be sure the seat is right for your child's size ⇒ *page 133, Important safety instructions for using child safety seats*. Please be sure to read and heed all of the important information and WARNINGS about child safety, Advanced Airbags, and the installation of child restraints in this chapter.

There is a lot you need to know about the Advanced Airbags in your vehicle and how they work when infants and children in child re-

straints are on the front passenger seat. Because of the large amount of important information, we cannot repeat it all here. We urge you to read the detailed information in this owner's manual about airbags and the Advanced Airbag System in your vehicle and the very important information about transporting children on the front passenger seat. Please be sure to heed the WARNINGS - they are extremely important for your safety and the safety of your passengers, especially infants and small children.

#### WARNING

- Accident statistics have shown that children are generally safer in the rear seat area than in the front seating position. Always restrain any child age 12 and under in the rear.
- All vehicle occupants and especially children must be restrained properly whenever riding in a vehicle. An unrestrained or improperly restrained child could be injured by striking the interior or by being ejected from the vehicle during a sudden maneuver or impact. An unrestrained or improperly restrained child is also at greater risk of injury or death through contact with an inflating airbag.
- A suitable child restraint properly installed and used at one of the rear seating positions provides the highest degree of protection for infants and small children in most accident situations.

#### WARNING

- Children on the front seat of any car even with Advanced Airbags can be seriously injured or even killed when an airbag inflates. A child in a rearward-facing child safety seat installed on the front passenger seat will be seriously injured and can be killed if the front airbag inflates.
- The inflating airbag will hit the child safety seat or infant carrier with great force and will smash the child safety seat and child against the backrest or door.

- Always install rear-facing child safety seats on the rear seat.
- If you must install a rearward facing child safety seat on the front passenger seat in exceptional circumstances and the **PASSENGER AIR BAG OFF** light does not come on and stay on, immediately install the rear-facing child safety seat in a rear seating position and have the air-bag system inspected immediately by your Audi dealer.

### **WARNING**

If, in exceptional circumstances, you must install a forward-facing child restraint on the front passenger's seat:

- Always make sure the forward-facing seat has been designed and certified by its manufacturer for use on a front seat with a passenger front and side airbag.
- Always follow the manufacturer's instructions provided with the child safety seat or carrier.
- Always move the passenger seat into its rearmost position in the seat's fore and aft adjustment range, as far away from the airbag as possible before installing the child restraint. The backrest must be adjusted to an upright position.
- Always make sure that the **PASSENGER AIR BAG OFF** light comes on and stays on all the time whenever the ignition is switched on.

### **Tips**

Always replace child restraints that were installed in a vehicle during a crash. Damage to a child restraint that is not visible could cause it to fail in another collision situation.

## Advanced front airbag system and children

Your vehicle is equipped with an “Advanced Airbag System” in compliance with United States Federal Motor Vehicle Safety Standard

(FMVSS) 208 as applicable at the time your vehicle was manufactured.

The Advanced Airbag system in your vehicle has been certified to meet the “low-risk” requirements for 3- and 6-year old children on the passenger side and small adults on the driver side. The low risk deployment criteria are intended to reduce the risk of injury through interaction with the airbag that can occur, for example, by being too close to the steering wheel and instrument panel when the airbag inflates. In addition, the system has been certified to comply with the “suppression” requirements of the Safety Standard, to turn off the front airbag for infants up to 12 months who are restrained on the front passenger seat in child restraints that are listed in the Standard.

Even though your vehicle is equipped with an Advanced Airbag system, all children, especially those 12 years and younger, should always ride in the back seat properly restrained for their age and size. The airbag on the passenger side makes the front seat a potentially dangerous place for a child to ride. The front seat is not the safest place for a child in a forward-facing child safety seat. It can be a very dangerous place for an infant or a larger child in a rearward-facing seat.

### Advanced Airbags and the weight-sensing mat in the front seat

The Advanced Airbag System in your vehicle detects the presence of an infant or child in a child restraint on the front passenger seat using the weight-sensing mat in the seat cushion and the sensor below the safety belt latch on the front passenger seat that measures the tension on the safety belt.

The weight-sensing mat measures total weight of the child and the child safety seat and a child blanket on the front passenger seat. The weight on the front passenger seat is related to the design of the child restraint and its “footprint”, the size and shape of the bottom of the child restraint as it sits on the

seat. The weight of a child restraint and its “footprint” vary for different kinds of child restraints and for the different models of the same kind of child restraint offered by child restraint manufacturers.

The weight ranges for the individual types, makes and models of child restraints that the NHTSA has specified in the Safety Standard together with the weight ranges of typical infants and typical 1 year-old child have been stored in the control unit of the Advanced Airbag System. When a child restraint is being used on the front passenger seat with a typical 1 year-old child, the Advanced Airbag System compares the weight measured by the weight sensing mat with the information stored in the electronic control unit.

The electronic control unit also registers the tension on the front passenger safety belt. The tension on the safety belt for the front passenger seat will be different for an adult who is properly using the safety belt as compared to the tension on the belt when it is used to attach a child restraint to the seat. The sensor below the latch for the safety belt for the front seat passenger measures the tension on the belt. The input from this sensor is then used with the weight to “decide”, whether there is a child restraint with a typical 1 year-old child on the front passenger seat and whether or not the airbag must be turned off.

### **Child restraints and Advanced Airbags**

Regardless of the child restraint that you use, make sure that it has been certified to meet United States Federal Motor Vehicle Safety Standards and has been certified by its manufacturer for use with an airbag. Always be sure that the child restraint is properly installed at one of the rear seating positions. If in exceptional circumstances you must use it on the front passenger seat, carefully read all of the information on child safety and Advanced Airbags and heed all of the applicable WARNINGS. Make certain that the child restraint is correctly recognized by the weight-sensing

mat inside the front passenger seat, that the front passenger airbag is turned off and that the airbag status is always correctly signaled by the **PASSENGER AIR BAG OFF** light.

Many types and models of child restraints have been available over the years, new models are introduced regularly incorporating new and improved designs and older models are taken out of production. Child restraints are not standardized. Child restraints of the same type typically have different weights and sizes and different ‘footprints,’ the size and shape of the bottom of the child restraint that sits on the seat, when they are installed on a vehicle seat. These differences make it virtually impossible to certify compliance with the requirements for advanced airbags with each and every child restraint that has ever been sold in the past or will be sold over the course of the useful life of your vehicle.

For this reason, the United States National Highway Traffic Safety Administration has published a list of specific type, makes and models of child restraints that must be used to certify compliance of the Advanced Airbag System in your vehicle with the suppression requirements of Federal Motor Vehicle Safety Standard 208. These child restraints are:

#### **Subpart A – Car bed child restraints**

<b>Model</b>	<b>Manufactured on or after</b>
Angel Guard Angel Ride AA2403FOF	September 25, 2007

#### **Subpart B – Rear-facing child restraints**

<b>Model</b>	<b>Manufactured on or after</b>
Century SmartFit 4543	December 1, 1999
Cosco Arriva 22-013PAW and base 22-999WHO	September 25, 2007
Evenflo Discovery Adjust Right 212	December 1, 1999

Model	Manufactured on or after
Evenflo First Choice 204	December 1, 1999
Graco Infant 8457	December 1, 1999
Graco Snugride	September 25, 2007
Peg Perego Primo Viaggio SIP IMUN00US	September 25, 2007

**Subpart C – Forward-facing and convertible child restraints**

Model	Manufactured on or after
Britax Roundabout E9L02xx	September 25, 2007
Cosco Touriva 02519	December 1, 1999
Cosco Summit Deluxe High Back Booster 22-262	September 25, 2007
Cosco High Back Booster 22-209	September 25, 2007
Evenflo Tribute V 379xxxx	September 25, 2007
Evenflo Medallion 254	December 1, 1999
Evenflo Generations 352xxxx	September 25, 2007
Graco ComfortSport	September 25, 2007
Graco Toddler Safety Seat Step 2	September 25, 2007
Graco Platinum Cargo	September 25, 2007

**! WARNING**

To reduce the risk of serious injury, make sure that the **PASSENGER AIR BAG OFF** light comes on and stays on whenever a child restraint is installed on the front passenger seat and the ignition is switched on.

- Take the child restraint off the front passenger seat and install it properly at one of the rear seat positions if the **PASSENGER AIR BAG OFF** light does not stay on.
- Have the airbag system inspected by your authorized Audi dealer immediately.

**i Tips**

The child seats listed in categories A to C have been statically tested by Audi only for the Advanced Airbag function.

**Important safety instructions for using child safety seats**

*Correct use of child safety seats substantially reduces the risk of injury in an accident!*

As the driver, you are responsible for the safety of everybody in the vehicle, especially children:

- ▶ Always use the right child safety seat for each child and always use it properly ⇒ *page 135*.
- ▶ Always carefully follow the child safety seat manufacturer's instructions on how to route the safety belt properly through the child safety seat.
- ▶ When using the vehicle safety belt to install a child safety seat, you must first activate the convertible locking retractor on the safety belt to prevent the child safety seat from moving ⇒ *page 140*.
- ▶ Push the child safety seat down with your full weight to get the safety belt really tight so that the seat cannot move forward or sideways more than one inch (2.5 cm).
- ▶ If a strap or tether is being used to tie the child safety seat to the front passenger seat, make sure that it is not so tight that it causes the weight-sensing mat to measure more weight than is actually on the seat.
- ▶ Secure unused safety belts on the rear seat ⇒ *page 135*.

Always remember: Even though your vehicle is equipped with an Advanced Airbag system, all children, especially those 12 years and younger, should always ride in the back seat properly restrained for their age and size. ▶

 **WARNING**

Not using a child safety seat, using the wrong child safety seat or improperly installing a child restraint increases the risk of serious personal injury and death.

- All vehicle occupants and especially children must always be restrained properly whenever riding in a vehicle.
  - An unrestrained or improperly restrained child can be injured or killed by being thrown against the inside of the vehicle or by being ejected from it during a sudden maneuver or impact.
  - An unrestrained or improperly restrained child is at much greater risk of injury or death by being struck by an inflating airbag.
- Commercially available child safety seats are required to comply with U.S. Federal Motor Vehicle Safety Standard (FMVSS) 213 (in Canada CMVSS 213).
  - When buying a child restraint, select one that fits your child and the vehicle.
  - Only use child restraint systems that fully contact the flat portion of the seat cushion. The child restraint must not tip or lean to either side. Audi does not recommend using child safety seats that rest on legs or tube-like frames. They do not provide adequate contact with the seat.
  - Always heed all legal requirements pertaining to the installation and use of child safety seats and carefully follow the instructions provided by the manufacturer of the seat you are using.
- Never allow children under 4 ft. 9 in. (1.4 m) to wear a normal safety belt. However, the rear seat in the TT Coupe is designed to permit children who are between 4 ft. 3 in. (1.3 m) and 4 ft. 11 in. (1.5 m) tall to use the available three-point lap and shoulder safety belts.
- Never let more than one child occupy a child safety seat.

- Never let babies or older children ride in a vehicle while sitting on the lap of another passenger.
  - Holding a child in your arms is never a substitute for a child restraint system.
  - The strongest person could not hold the child with the forces that exist in an accident. The child will strike the interior of the vehicle and can also be struck by the passenger.
  - The child and the passenger can also injure each other in an accident.
- Never install rear-facing child safety seats or infant carriers on the front passenger seat. A child will be seriously injured and can be killed when the passenger airbag inflates – even with an Advanced Airbag System.
- The inflating airbag will hit the child safety seat or infant carrier with great force and will smash the child safety seat and child against the backrest, door or roof.
- Always install rear-facing child safety seats or infant carriers on the rear seat.
- Forward-facing child safety seats installed on the front passenger's seat can interfere with the airbag when it inflates and cause serious injury to the child. Always install forward-facing child safety seats on the rear seat.
- If exceptional circumstances require the use of a forward-facing child restraint on the front passenger's seat, the child's safety and well-being require that the following special precautions be taken:
  - Make sure the forward-facing seat has been designed and certified by its manufacturer for use on a front seat with a passenger front and side airbag.
  - Always carefully follow the manufacturer's instructions provided with the child safety seat or carrier.
  - Always move the front passenger seat into the rearmost position of the passenger seat's fore and aft adjustment range, and as far away from the airbag

as possible before installing the child restraint.

- Always make sure that nothing prevents the front passenger's seat from being moved to the rearmost position in its fore and aft adjustment range.
- Always make sure that the backrest is in the upright position.
- Always buckle the child safety seat firmly in place even if a child is not sitting in it. A loose child safety seat can fly around during a sudden stop or in a collision.
- Always read and heed all WARNINGS whenever using a child restrained in a vehicle is being used ⇒ *page 100, Safety belts*, ⇒ *page 108, Airbag system* and ⇒ *page 130, Child Safety*.

**! WARNING**

- To reduce the risk of serious injury, make sure that the **PASSENGER AIR BAG OFF** light comes on and stays on whenever a child restraint is installed on the front passenger seat and the ignition is switched on.
- Take the child restraint off the front passenger seat and install it properly at one of the rear seat positions if the **PASSENGER AIR BAG OFF** light does not stay on.
  - Have the airbag system inspected by your authorized Audi dealer immediately.

**Secure unused safety belts on the rear seat**



**Fig. 112** Schematic overview: keep unused safety belts away from children in child safety seats. - outer rear safety belt,

If a child safety seat is used on the rear bench, especially with LATCH universal lower anchorages, the unused safety belts **must** be secured so that the child in the child restraint cannot reach them ⇒ **!**

- Fasten the unused safety belt behind the child seat and let the belt retractor wind up the safety belt webbing.

**! WARNING**

A child in a child safety seat installed with the LATCH lower anchorages or with the standard safety belt or a child in a booster seat on the rear seat could play with unused rear seat safety belts and become entangled. This could cause the child serious personal injury and even death.

- Always secure unused rear seat safety belts out of reach of children in child seats such as by fastening the unused safety belt behind the child seat and letting the belt retractor wind up the webbing.

**Child safety seats**

**Infant seats**

*Babies and infants up to about one year old and 20 lbs. or 9 kg need special rearward-facing child restraints that support the back, neck and head in a crash.*

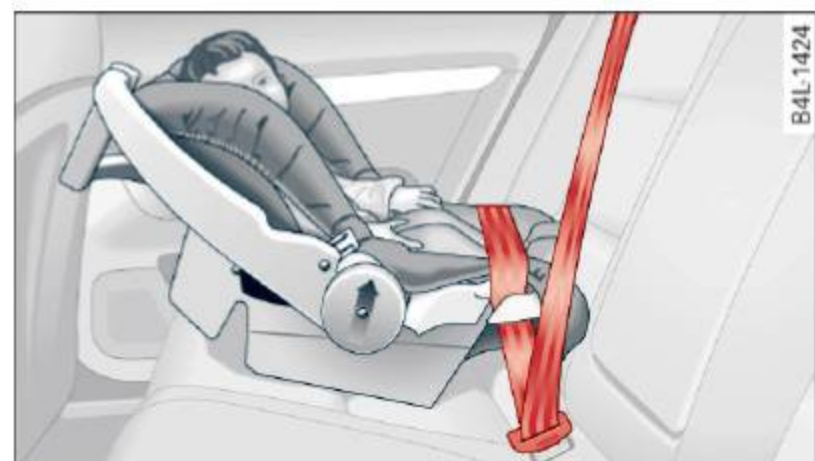

**Fig. 113** Schematic overview: rearward-facing infant seat, properly installed on the rear seat

- ▶ When using the vehicle safety belt to install a child safety seat, you must first activate the convertible locking retractor on the safety belt to prevent the child safety seat ▶

from moving ⇒ *page 140* or install the seat using the LATCH attachments.

- ▶ Push the child safety seat down with your full weight to get the safety belt really tight so that the seat cannot move forward or sideways more than one inch (2.5 cm).
- ▶ Secure unused safety belts on the rear seat ⇒ *page 135*.

Infants up to about one year (20 lbs. or 9 kg) are best protected in special infant carriers and child safety seats designed for their age group. Many experts believe that infants and small children should ride only in special restraints in which the child faces the back of the vehicle. These infant seats support the baby's back, neck and head in a crash ⇒ *fig. 113*.

The airbag on the passenger side makes the front seat a potentially dangerous place for a child to ride. The front seat is not the safest place for a child in a forward-facing child seat. It is a very dangerous place for an infant or a larger child in a rearward-facing seat.

### WARNING

Not using a child safety seat, using the wrong child safety seat or improperly installing a child restraint increases the risk of serious personal injury and death in a crash.

- Never install rear-facing child safety seats or infant carriers on the front passenger seat - even with an Advanced Airbag System. A child will be seriously injured and can be killed when the inflating airbag hits the child safety seat or infant carrier with great force and smashes the child safety seat and child against the backrest, door or roof ⇒ *page 110, Child restraints on the front seat - some important things to know*.
- Always install rear-facing child safety seats or infant carriers on the rear seat.
- Never install a rear-facing child restraint in the forward-facing direction. Such restraints are designed for the special needs of infants and very small children

and cannot protect them properly if the seat is forward-facing.

- If you must install a rearward facing child safety seat on the front passenger seat because of exceptional circumstances and the **PASSENGER AIR BAG OFF** light does not come on and stay on, immediately install the rear-facing child safety seat in a rear seating position and have the airbag system inspected by your Audi dealer.
- Always read and heed all WARNINGS whenever using a child restrained in a vehicle is being used ⇒ *page 100, Safety belts*, ⇒ *page 108, Airbag system* and ⇒ *page 130, Important things to know*.

### Convertible child safety seats

Properly used convertible child safety seats can help protect toddlers and children over age one who weigh between 20 and 40 lbs. (9 and 18 kg) in a crash.



**Fig. 114** Schematic overview: installation of the attachments applicable to a LATCH seat

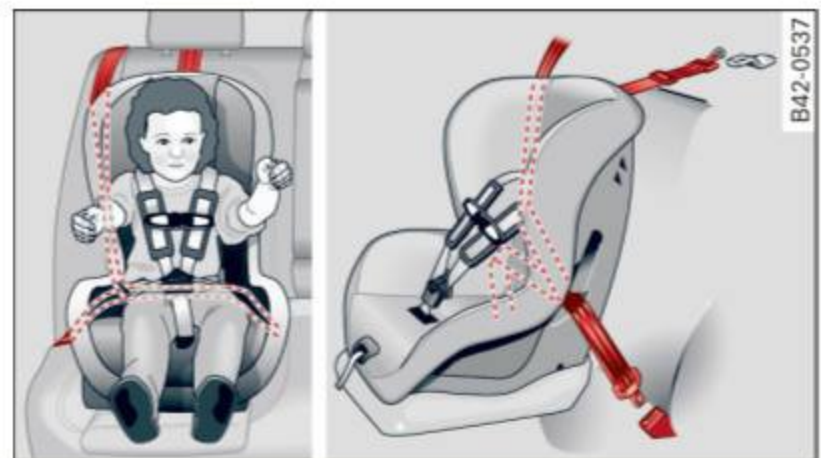

**Fig. 115** Schematic overview: installation of the seat using the vehicle's safety belt system

- ▶ When using the vehicle safety belt to install a child safety seat, you must first activate the convertible locking feature on the safety ▶

belt to prevent the child safety seat from moving ⇒ *page 140* or install the seat using the LATCH attachments.

- ▶ Push the child safety seat down with your full weight to get the safety belt really tight so that the seat cannot move forward or sideways more than one inch (2.5 cm) ⇒ *page 140*.
- ▶ If the child safety seat is equipped with a tether strap, attach it to the tether anchors ⇒ *page 147*.
- ▶ Secure unused safety belts on the rear seat ⇒ *page 135*.

A toddler or child is usually too large for an infant restraint if it is more than one year old and weighs more than 20 lbs. (9 kg).

Toddlers and children who are older than one year up to about 4 years old and weigh more than 20 lbs. (9 kg) up to 40 lbs. (18 kg) must always be properly restrained in a child safety seat certified for their size and weight ⇒ *fig. 114* and ⇒ *fig. 115*.

The airbag on the passenger side makes the front seat a potentially dangerous place for a child to ride. The front seat is not the safest place for a child in a forward-facing child safety seat. It is a very dangerous place for an infant or a larger child in a rearward-facing seat.

### WARNING

Not using a child safety seat, using the wrong child safety seat or improperly installing a child restraint increases the risk of serious personal injury and death in a collision or other emergency situation.

- Children on the front seat of any car, even with Advanced Airbags, can be seriously injured or even killed when an airbag inflates. A child in a rearward-facing child safety seat installed on the front passenger seat will be seriously injured and can be killed if the front airbag inflates – even with an Advanced Airbag System.
- The inflating airbag will hit the child safety seat or infant carrier with great

force and will smash the child safety seat and child against the backrest, door or roof.

- Always install rear-facing child safety seats on the rear seat.
- If you must install a rearward facing child safety seat on the front passenger seat because of exceptional circumstances and the **PASSENGER AIR BAG OFF** light does not come on and stay on, immediately install the rear-facing child safety seat in a rear seating position and have the airbag system inspected by your Audi dealer.
- Always read and heed all WARNINGS whenever using a child restrained in a vehicle is being used ⇒ *page 100, Safety belts*, ⇒ *page 108, Airbag system* and ⇒ *page 130, Important things to know*.

### WARNING

If exceptional circumstances require the use of a forward-facing child restraint on the front passenger's seat, the child's safety and well-being require that the following special precautions be taken:

- Make sure the forward-facing seat has been designed and certified by its manufacturer for use on a front seat with a passenger front and side airbag.
- Always follow the manufacturer's instructions provided with the child safety seat or infant carrier.
- Always move the front passenger seat into the rearmost position of the passenger seat's fore and aft adjustment range, and as far away from the airbag as possible before installing the child restraint.
- Always make sure that nothing prevents the front passenger's seat from being moved to the rearmost position in its fore and aft adjustment range.
- Always make sure the backrest is in an upright position.
- Make sure that the **PASSENGER AIR BAG OFF** light comes on and stays on all the

time whenever the ignition is switched on.

- If the light does not stay on, perform the checks ⇒ *page 119, Monitoring the Advanced Airbag System.*
- Take the child restraint off the front passenger seat and install it properly at one of the rear seat positions if the **PASSENGER AIR BAG OFF** light does not stay on whenever the ignition is switched on.

### Booster seats and safety belts

*Properly used booster seats can help protect children weighing between about 40 lbs. and 80 lbs. (18 kg and 36 kg) who are less than 4 ft. 9 in. (57 inches/1.45 meters) tall.*



**Fig. 116** Rear seat: child properly restrained in a booster seat

Booster seats raise these children up so that the safety belt will pass properly over the stronger parts of their bodies and the safety belt can help protect them in a crash.

- ▶ Do not use the convertible locking retractor when using the vehicle's safety belt to restrain a child on a booster seat.
- ▶ The shoulder belt must lie as close to the center of the child's collar bone as possible and must lie and snug on the upper body. It must never lie across the throat or neck. The lap belt must lie across the pelvis and never across the stomach or abdomen. Make sure the belt lies flat and snug. Pull on the belt to tighten if necessary.
- ▶ Secure unused safety belts on the rear seat ⇒ *page 135.*

Children up to at least 8 years old (over 40 lbs. or 18 kg) are best protected in child safety seats designed for their age and weight. Experts say that the skeletal structure, particularly the pelvis, of these children is not fully developed, and they must not use the vehicle safety belts without a suitable child restraint.

It is usually best to put these children in appropriate booster seats. Be sure the booster seat meets all applicable safety standards.

Booster seats raise the seating position of the child and reposition both the lap and shoulder parts of the safety belt so that they pass across the child's body in the right places. The routing of the belt over the child's body is very important for the child's protection, whether or not a booster seat is used. Children age 12 and under must always ride in the rear seat.

Children who are at least 4 ft. 9 in. (57 inches/1.45 meters) tall can generally use the vehicle's three point lap and shoulder belts. Never use the lap belt portion of the vehicle's safety belt alone to restrain any child, regardless of how big the child is. Always remember that children do not have the pronounced pelvic structure required for the proper function of lap belt portion of the vehicle's three point lap and shoulder belts. The child's safety absolutely requires that a lap belt portion of the safety belt be fastened snugly and as low as possible around the pelvis. Never let the lap belt portion of the safety belt pass over the child's stomach or abdomen.

In a crash, airbags must inflate within a blink of an eye and with considerable force. In order to do its job, the airbag needs room to inflate so that it will be there to protect the occupant as the occupant moves forward into the airbag.

A vehicle occupant who is out of position and too close to the airbag gets in the way of an inflating airbag. When an occupant is too close, he or she will be struck violently and will receive serious or possibly even fatal injury.

In order for the airbag to offer protection, it is important that all vehicle occupants, especially any children, who must be in the front seat because of exceptional circumstances, be properly restrained and as far away from the airbag as possible. By keeping room between the child's body and the front of the passenger compartment, the airbag can inflate completely and provide supplemental protection in certain frontal collisions.

### WARNING

Not using a booster seat, using the booster seat improperly, incorrectly installing a booster seat or using the vehicle safety belt improperly increases the risk of serious personal injury and death in a collision or other emergency situation. To help reduce the risk of serious personal injury and/or death:

- The shoulder belt must lie as close to the center of the child's collar bone as possible and must lie and snug on the upper body. It must never lie across the throat or neck. The lap belt must lie across the pelvis and never across the stomach or abdomen. Make sure the belt lies flat and snug. Pull on the belt to tighten if necessary.
- Failure to properly route safety belts over a child's body will cause severe injuries in an accident or other emergency situation ⇒ *page 100*.
- Children on the front seat of any car, even with Advanced Airbags, can be seriously injured or even killed when an airbag inflates.
- Never let a child stand or kneel on any seat, for example the front seat.
- Never let a child ride in the cargo area of your vehicle.
- Always remember that a child leaning forward, sitting sideways or out of position in any way during an accident can be struck by a deploying airbag. This will result in serious personal injury or death.
- If you must install a booster seat on the front passenger seat because of excep-

tional circumstances the **PASSENGER AIR BAG OFF** light must come on and stay on, whenever the ignition is switched on.

- If the **PASSENGER AIR BAG OFF** light does not come on and stay on, perform the checks described ⇒ *page 119, Monitoring the Advanced Airbag System*.
- Take the child restraint off the front passenger seat and install it properly at one of the rear seat positions if the **PASSENGER AIR BAG OFF** light does not stay on whenever the ignition is switched on.
- Always read and heed all WARNINGS whenever using a child restrained in a vehicle is being used ⇒ *page 100, Safety belts*, ⇒ *page 108, Airbag system* and ⇒ *page 130, Important things to know*.

### Booster seats on the rear seat

Children who are about 7 years and older, who weigh more than 55 lbs. (25 kg) and are not taller than 4'11" (1.5 m) are best protected when properly restrained on the rear seat.

Due to limited rear seat head clearance children 4'3" (1.3 m) and taller must not use booster seats on the rear seat of your Audi TT Coupe. The rear seat of your Audi TT Coupe has been specially designed to permit children who are between 4'3" (1.3 m) and 4'11" (1.5 m) tall (about 7 to 12 years old) to use the available three-point lap and shoulder safety belts.

### WARNING

- The rear seat area is too small to safely transport passengers taller than 4'11" (1.5 m).
- Persons taller than 4'11" (1.5 m) as well as children in booster seats who are too close to the rear window and roof can suffer severe head and neck injuries when the rear lid is closed or in a crash.
- The minimum clearance between the passengers' heads and the rear window

must never - under any circumstances - be less than 1 inch (2.5 cm.) when the passengers sits fully upright.

- Always make sure that the rear seat passengers cannot be struck when the rear lid is closed.

### Booster seats on the front seat

Children aged about 7 years and older and weighing more than 55 lbs (25 kg) who are between 4'3" (1.3 m) and 4'11" (1.5 m) tall may in exceptional circumstances ride on the front passenger's seat. Children less than 4'9" (1.4 m) tall must sit on a certified booster seat and properly wear the vehicle's three-point lap and shoulder safety belt.

Always securely latch the passenger seat at the very rear of its fore and aft adjustment range. The backrest must be adjusted to an upright position.

#### WARNING

If you must install a booster seat child restraint on the front passenger seat:

- Make sure the booster seat has been designed and certified by its manufacturer for use on a front seat with a passenger front and side airbag.
- Always follow the manufacturer's instructions provided with the booster seat.
- Always move the passenger seat to the very rear of its fore and aft adjustment range, as far away from the airbag as possible.
- Always make sure that the passenger seat is securely latched in place before installing the booster seat. The backrest must be adjusted to an upright position.
- If the passenger seat cannot be securely latched in the very rear of its fore and aft adjustment range, then the passenger front airbag must be turned off with the ON / OFF switch.

## Installing a child safety seat

### Securing a child safety seat using a safety belt

*Safety belts for the rear seats and the front passenger can be locked with the convertible locking retractor to properly secure child safety seats.*

The safety belts emergency locking retractors for the rear seats safety belts and for the front passenger's seat safety belt have a convertible locking retractor for child restraints. The safety belt must be locked so that belt webbing cannot unreel. The retractor can be activated to lock the safety belt and prevent the safety belt webbing from loosening up during normal driving. A child safety seat can only be properly installed when the safety belt is locked so that the child and child safety seat will stay in place.

Always remember: Even though your vehicle is equipped with an Advanced Airbag system, all children, especially those 12 years and younger, should always ride in the back seat properly restrained for their age and size.

#### WARNING

Improperly installed child safety seats increase the risk of serious personal injury and death in a collision.

- Always make sure that the safety belt retractor is locked when installing a child safety seat. An unlocked safety belt retractor cannot hold the child safety seat in place during normal driving or in a crash.
- Always buckle the child safety seat firmly in place even if a child is not sitting in it. A loose child safety seat can fly around during a sudden stop or in a collision
- If the backrest is not securely latched, the child and the child restraint will be thrown forward together with the backrest and will strike parts of the vehicle

interior. The child can be seriously injured or killed.

- Never install rear-facing child safety seats or infant carriers on the front passenger seat. A child will be seriously injured and can be killed when the passenger airbag inflates.
- The inflating airbag will hit the child safety seat or infant carrier with great force and will smash the child safety seat and child against the backrest, door or roof.
- Always install rear-facing child safety seats or infant carriers on the rear seat.
- Forward-facing child safety seats or infant carriers installed on the front passenger's seat may interfere with the deployment of the airbag and cause serious injury to the child.
- It is safer to install a forward-facing child safety seat on the rear seat.
- Always read and heed all WARNINGS whenever using a child restrained in a vehicle is being used ⇒ *page 130*. Special precautions apply when installing a child safety seat on the front passenger seat ⇒ *page 110, Child restraints on the front seat – some important things to know*.

### WARNING

Always take special precautions if you must install a forward or rearward-facing child restraint on the front passenger's seat in exceptional situations:

- Whenever a forward or rearward-facing child restraint is installed on the front passenger seat, the **PASSENGER AIR BAG OFF** light must come on and stay on whenever the ignition is switched on.
- If the **PASSENGER AIR BAG OFF** light does not come on and stay on, perform the checks described ⇒ *page 119, Monitoring the Advanced Airbag System*.
- Take the child restraint off the front passenger seat and install it properly at one of the rear seat positions if the **PASSEN-**

**GER AIR BAG OFF** light does not stay on whenever the ignition is switched on.

- Improper installation of child restraints can reduce their effectiveness or even prevent them from providing any protection.
- An improperly installed child restraint can interfere with the airbag as it deploys and seriously injure or even kill the child.
- Always carefully follow the manufacturer's instructions provided with the child safety seat or carrier.
- Never place additional items on the seat that can increase the total weight registered by the weight-sensing mat and can cause injury in a crash.

### WARNING

Forward-facing child restraints:

- Always make sure the forward-facing seat has been designed and certified by its manufacturer for use on a front seat with a passenger front and side airbag.
- Never put the forward-facing child restraint up, against or very near the instrument panel.
- Always move the passenger seat into its rearmost position in the seat's fore and aft adjustment range, as far away from the airbag as possible before installing the forward-facing child restraint. The backrest must be adjusted to an upright position.
- Make sure that the **PASSENGER AIR BAG OFF** light comes on and stays on all the time whenever the ignition is switched on.

### WARNING

Rearward-facing child restraints:

- A child in a rearward-facing child safety seat installed on the front passenger seat will be seriously injured and can be killed if the front airbag inflates - even with an Advanced Airbag System.

- The inflating airbag will hit the child safety seat or infant carrier with great force and will smash the child safety seat and child against the backrest, door or roof.
- Always be especially careful if you must install a rearward facing child safety seat on the front passenger seat in exceptional circumstances.
- A tight tether strap on a rearward-facing child restraint attached to the front passenger seat can put too much pressure on the weight-mat in the seat and register a heavier weight in the Advanced Airbag System. The heavier weight registered can make the system work as though an adult were on the seat and deploy the Advanced Airbag when it must be suppressed causing serious or even fatal injury to the child.
- Make sure that the **PASSENGER AIR BAG OFF** light comes on and stays on all the time whenever the ignition is switched on.
- If the **PASSENGER AIR BAG OFF** light does not come on and stay on, immediately install the rear-facing child safety seat in a rear seating position and have the airbag system inspected by your Audi dealer.

### Activating the convertible locking retractor

*Use the convertible locking retractor to secure a child restraint.*

Always heed the child safety seat manufacturer's instructions when installing a child restraint in your vehicle. To activate the convertible locking retractor:

- ▶ Place the child restraint on a seat, preferably on the rear seat.
- ▶ Slowly pull the belt **all the way out**.
- ▶ Route it around or through the child restraint belt path ⇒ .
- ▶ Push the child safety seat down with your full weight to get the safety belt really tight.

- ▶ Insert the belt tongue into the buckle for that seating position.
- ▶ Guide the safety belt back into the retractor until the belt lies flat and snug on the child safety seat.
- ▶ You should hear a “clicking” noise as the belt winds back into the inertia reel. Test the convertible locking retractor by pulling on the belt. You should no longer be able to pull the belt out of the retractor. The convertible locking retractor is now activated.
- ▶ Make sure that the red release button is facing away from the child restraint so that it can be unbuckled quickly.
- ▶ Pull on the belt to make sure the safety belt is properly tight and fastened so that the seat cannot move forward or sideways more than one inch (2.5 cm).

### WARNING

- Using the wrong child restraint or an improperly installed child restraint can cause serious personal injury or death in a crash.
- Always make sure that the safety belt retractor is locked when installing a child safety seat. An unlocked safety belt retractor cannot hold the child safety seat in place during normal driving or in a crash.
  - Always buckle the child safety seat firmly in place even if a child is not sitting in it. A loose child safety seat can fly around during a sudden stop or in a crash.
  - Always make sure the seat backrest to which the child restraint is installed is in an upright position and securely latched into place and cannot fold forward. Otherwise, the seatback with the child safety seat attached to it could fly forward in the event of an accident or other emergency situation.
  - Always read and heed all WARNINGS whenever using a child restrained in a vehicle is being used ⇒ *page 130*. Special precautions apply when installing a child safety seat on the front passenger seat ⇒ *page 110, Child restraints on the front seat – some important things to know*.

## Deactivating the convertible locking retractor

The convertible locking retractor for child restraints will be deactivated automatically when the belt is wound all the way back into the retractor.

- ▶ Press the red button on the safety belt buckle. The belt tongue will pop out of the buckle.
- ▶ Guide the safety belt all the way back into its stowed position.

Always let the safety belt retract completely into its stowed position. The safety belt can now be used as an ordinary safety belt without the convertible locking retractor for child restraints.

If the convertible locking retractor should be activated inadvertently, the safety belt must be unfastened and guided completely back into its stowed position to deactivate this feature. If the convertible locking retractor is not deactivated, the safety belt will gradually become tighter and uncomfortable to wear.

### WARNING

Improperly installed child safety seats increase the risk of serious personal injury and death in a collision.

- Never unfasten the safety belt to deactivate the convertible locking retractor for child restraints while the vehicle is moving. You would not be restrained and could be seriously injured in an accident.
- Always read and heed all WARNINGS whenever using a child restrained in a vehicle is being used ⇒ *page 130*. Special precautions apply when installing a child safety seat on the front passenger seat ⇒ *page 110, Child restraints on the front seat – some important things to know*.

## LATCH Lower anchorages and tethers for children

### Child Restraint System anchors and how are they related to child safety

To provide a simpler and more practicable way to attach the child restraint on the vehicle seat, Federal regulations require special lower anchorages in vehicles and devices on new child restraints to attach to the vehicle anchorages.

The combination of the tether anchorages and the lower anchorages is now generally called the **LATCH** system for “**L**ower **A**nchorages and **T**ethers for **C**hildren.” In Canada, the terms “top tether” with “lower universal anchorages” (or “lower universal anchorage bars”) are used to describe the system.

Forward-facing child restraints manufactured after September 1, 1999, are required by U.S. federal regulations to comply with new child head movement performance requirements. These new performance requirements make a tether necessary on most new child seats.

Installing a child restraint that requires a top tether without one can seriously impair the performance of the child restraint and its ability to protect the child in a collision. Installing a child restraint that requires a top tether without the top tether may be a violation of state law.

Child restraint manufacturers offer LATCH lower anchorages on their child seats with hook-on or push-on connectors attached to adjustable straps.

In addition to the LATCH lower anchorages, these child restraint systems usually require the use of tether straps to help keep the child restraint firmly in place.

### WARNING

Improper installation of child restraints will increase the risk of injury and death in a crash.

- Always follow the instructions provided by the manufacturer of the child restraint you intend to install in your vehicle.
- Never install a child restraint without a properly attached top tether strap if the child restraint manufacturer's instructions require the top tether strap to be used.
- Improper use of child restraint LATCH lower anchorage points can lead to injury in a collision. The LATCH lower anchorage points are designed to withstand only those loads imposed by correctly fitted child restraints.
- Never mount two child restraint systems on one LATCH lower anchorage point.
- Never secure or attach any luggage or other item to the LATCH lower anchorages.

### **i** Tips

- In Canada, the terms “top tether” with “lower universal anchorages” (or “lower universal anchorage bars”) are used to describe the system.
- In other countries, the term “ISOFIX” is used to describe the lower anchorages.

### Location

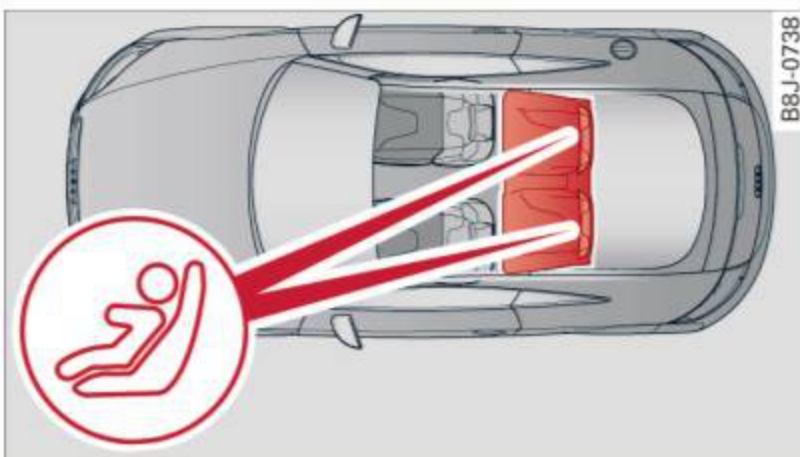

**Fig. 117** Schematic overview: LATCH anchorage point locations

The illustration shows the seating locations in your vehicle which are equipped with the lower universal anchorages system.

### Description

The lower anchorage positions are marked for quick locating.



**Fig. 118** Rear seatbacks: locator buttons for lower anchorages

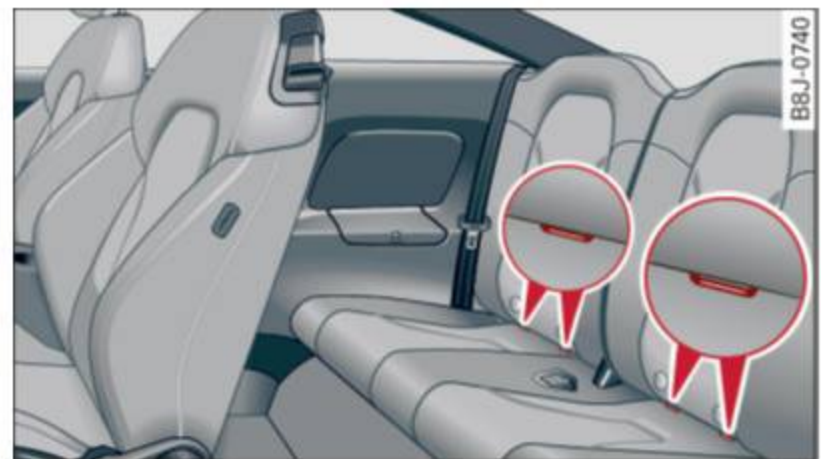

**Fig. 119** Rear seats: lower anchorage bracket locations

### Attachment locator markers for lower anchorages

Circular locator buttons on the rear seatback indicate the lower anchorage locations on the rear seating positions ⇒ *fig. 118*.

### Lower anchorages

The lower anchorage attachment points are located between the rear seatback and rear seat cushion ⇒ *fig. 119*.

Lower anchorages secure the child restraint in the seat without using the vehicle's safety belts. Anchorages provide a secure and easy-to-use attachment and minimize the possibility of improper child restraint installation.

All child restraints manufactured after September 1, 2002, must have lower anchorage attachments for the *LATCH* system.

Remember that the lower anchorage points are only intended for installation and attachment of child restraints specifically certified for use with *LATCH* lower anchorages. Child

restraints that are not equipped with the lower anchorage attachments can still be installed in compliance with the child restraint manufacturer's instructions on using vehicle safety belts.

### WARNING

Improper use of LATCH lower anchorages can cause serious personal injury in an accident.

- Always carefully follow the child restraints manufacturer's instructions for proper installation of the child restraint and proper use of the lower anchorages or safety belts in your vehicle.
- Never secure or attach any luggage or other items to the *LATCH* lower anchorages.
- Always read and heed the important information about child restraints in this chapter and WARNINGS ⇒ page 130, *Child Safety*.

### Guidance fixtures for lower anchorages

*Special guidance fixtures increase the convenience of the lower anchorages and are available from your authorized Audi dealer.*

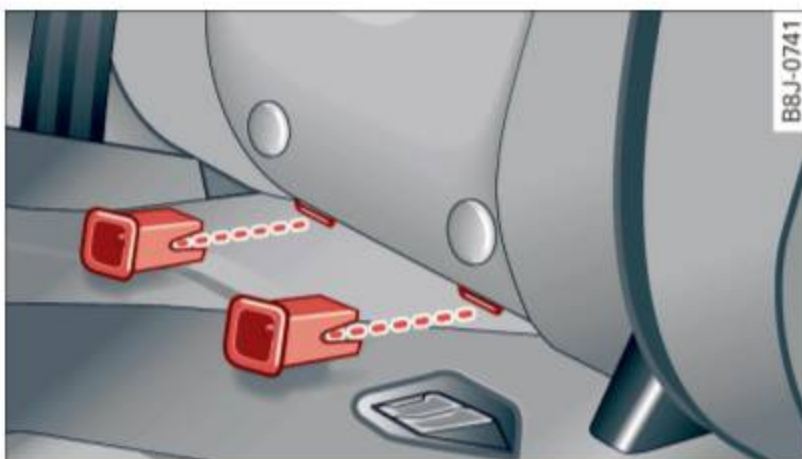

Fig. 120 Rear seats: installing the guidance fixtures

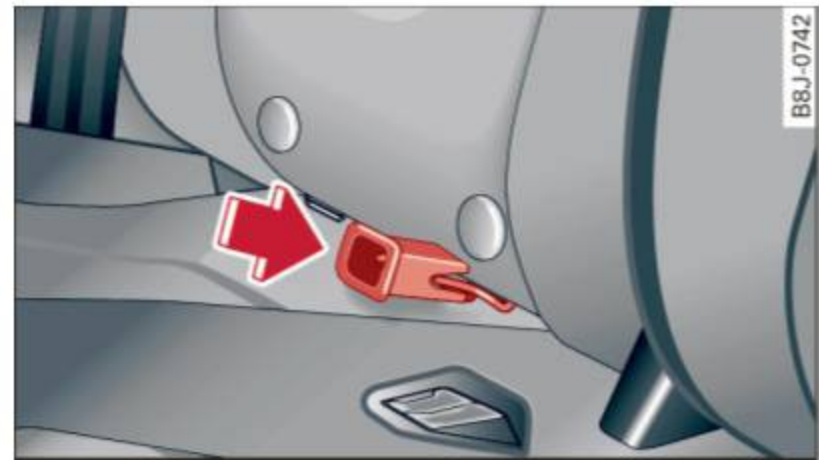

Fig. 121 Close-up: fitting the guidance fixture over the lower anchorage bracket

The lower anchorage attachment points are located on the rear seats between the seat-back and the seat cushion. Special guidance fixtures increase the convenience of the lower anchorages and help protect the seat material from possible damage when installing child restraints.

### Installing the guidance fixtures

- ▶ Push down on the seat cushion so that the lower anchorages are visible.
- ▶ Hold the guidance fixture with the part number facing downward and push it in the direction of the arrow onto the anchorage ⇒ fig. 121.
- ▶ Make sure that each of the two guidance fixtures per seat snaps into place.

### Removing the guidance fixtures

- ▶ Remove the child restraint according the child restraint manufacturer's instructions.
- ▶ Push down on the seat cushion so that the lower anchorages are visible.
- ▶ Pull off the guidance fixtures from the lower anchorages.
- ▶ Always remove the guidance fixtures and keep them in a safe place when not in use.

You may find it easier to install child restraints equipped with hooks attached to straps without the guidance fixtures in place. If this is the case, remove the guidance fixtures by pulling them off the anchorages. However, the guidance fixtures can help you to locate the *LATCH* anchorages. ▶

**! WARNING**

Improper use of tether anchorages or lower anchorages can cause serious personal injury in a crash.

- Always carefully follow the child restraint manufacturer's instructions for proper installation and use of child restraint systems.
- Never use the *LATCH* or tether anchorages to attach safety belts or other kinds of occupant restraints.
- Child restraint tether attachments and lower attachments are only designed to secure a child restraint that has been equipped to use these anchorages.
- Tether anchorages and lower anchorages are designed to withstand only those loads imposed by correctly fitted child restraints. Under no circumstances can they be used safely for adult or child safety belts or harnesses.
- Never mount more than one child restraint to a single tether or to a lower anchorage point. Attaching two child restraints to a single anchorage point can cause the anchorage to fail and cause serious personal injury in a crash.

**! Note**

- Remove the guidance fixtures before folding the rear seatback to prevent damaging the seat cushion.
- If you leave the guidance fixtures installed for several days, they could leave a mark on the upholstery on the seat cushion and backrest in the area that the guidance fixtures were installed. The upholstery would also be permanently stretched around the guidance fixtures. This applies especially to leather seats.

**Installing a child restraint with LATCH lower anchorages**

Whenever you install a child restraint always follow the child restraint manufacturer's instructions.

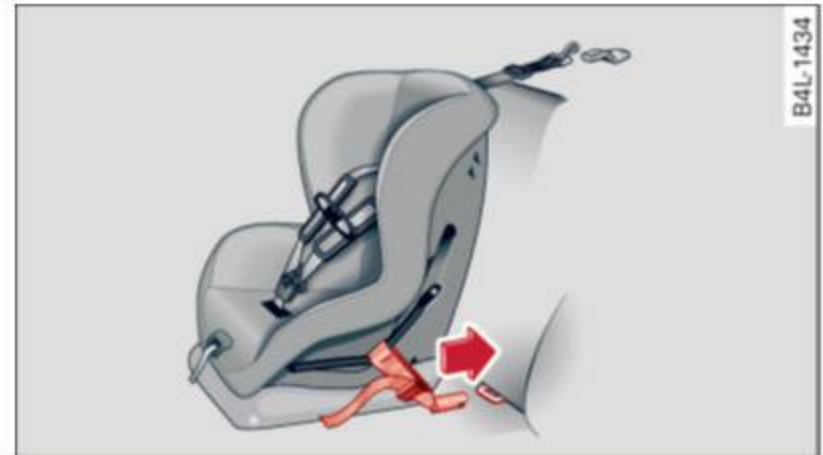

Fig. 122 Lower anchorages: proper mounting

**Mounting**

- ▶ Make sure the seatback of the rear seat bench is in the upright position and securely latched in place.
- ▶ Attach both hook-on connectors with the spring catch release on the child safety seat onto the LATCH lower anchorage so that the connectors lock into place ⇒ *fig. 122*.
- ▶ Pull on the connector attachments to make sure they are properly attached to the LATCH lower anchorage.
- ▶ Pull straps tight following the child restraint manufacturer's instructions.

**Releasing**

- ▶ Loosen the tension on the straps following the child restraint manufacturer's instructions.
- ▶ Depress the spring catches to release the anchorage hooks from the lower anchorages.

Remember: Use tether straps to help keep the child restraint firmly in place.

**! WARNING**

Improper use of the LATCH system can increase the risk of serious personal injury and death in an accident.

- These anchors were developed only for child safety seats using the “LATCH” system.
- Never attach other child safety seats, belts or other objects to these anchors.
- Always make sure that you hear a click when latching the seat in place. If you do not hear a click the seat is not secure and could fly forward and hit the interior of the vehicle, or be ejected from the vehicle.

### WARNING

Improper installation of child restraints will increase the risk of injury in an accident.

- Always follow the child restraint system manufacturer's instructions for proper installation of the child restraint system and proper use of tether straps as well as the lower anchorages or safety belts in your vehicle.
- Always read and heed the important information and WARNINGS about child safety and the installation of child restraint systems ⇒ *page 130, Child Safety*.

## Tether anchors and tether straps



**Fig. 123** Tether anchors: attachment hook locations behind the rear seatbacks

The tether anchors for the rear seating positions are located on the backside of the rear seatbacks ⇒ *fig. 123*.

A tether is a straight or V-shaped strap that attaches the top part of a child restraint to special anchorage points in the vehicle.

The purpose of the tether is to reduce the forward movement of the child restraint in a crash, in order to help reduce the risk of head injury that could be caused by striking the vehicle interior.

Forward facing child restraints manufactured after September 1, 1999, are required by U.S. federal regulations to comply with new child head movement performance requirements. These new performance requirements make a tether necessary on most new child safety seats.

### WARNING

Improper installation of child restraints will increase the risk of injury and death in a crash.

- Always follow the instructions provided by the manufacturer of the child restraint you intend to install in your Audi.
- Improper use of child restraint anchors (including tether anchors) can lead to injury in a collision. The anchors are designed to withstand only those loads imposed by correctly fitted child restraints.
- Never mount two child restraint systems on one LATCH lower anchor point.
- Never attach two child restraint systems to one tether strap or tether anchorage.
- Never attach a tether strap to a tie-down hook in the luggage compartment.
- Never use child restraint tether anchorages to secure safety belts or other kinds of occupant restraints.
- Never secure or attach any luggage or other items to the LATCH lower anchorages or to the tether anchors.
- If a tether or other strap is used to attach a child restraint to the front passenger seat, make sure that it is not so tight, that it causes the weight-sensing mat to measure more weight than is actually on the seat.
- The heavier weight registered can make the Advanced Airbag System work as though an adult were on the seat and deploy the Advanced Airbag when it must

be suppressed causing serious or even fatal injury to the child.

- If you must install a rearward facing child safety seat on the front passenger seat because of exceptional circumstances and the **PASSENGER AIR BAG OFF** light does not come on and stay on, immediately install the rear-facing child safety seat in a rear seating position and have the airbag system inspected by your Audi dealer.

### Installing the upper tether strap on the anchorage

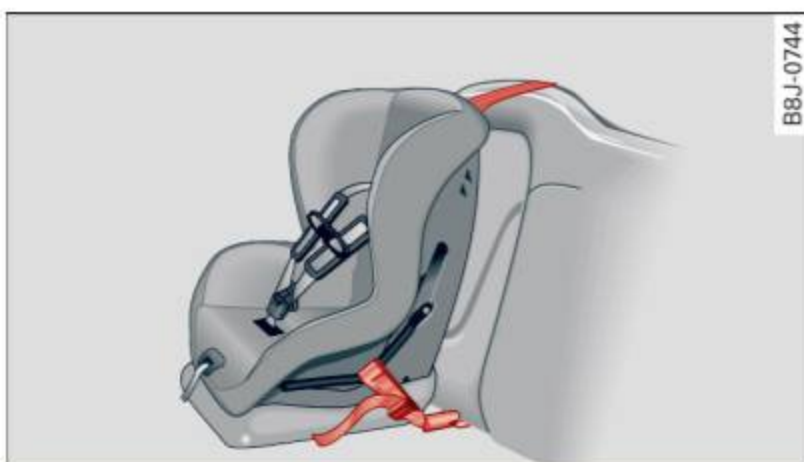

Fig. 124 Tether strap: proper routing and mounting

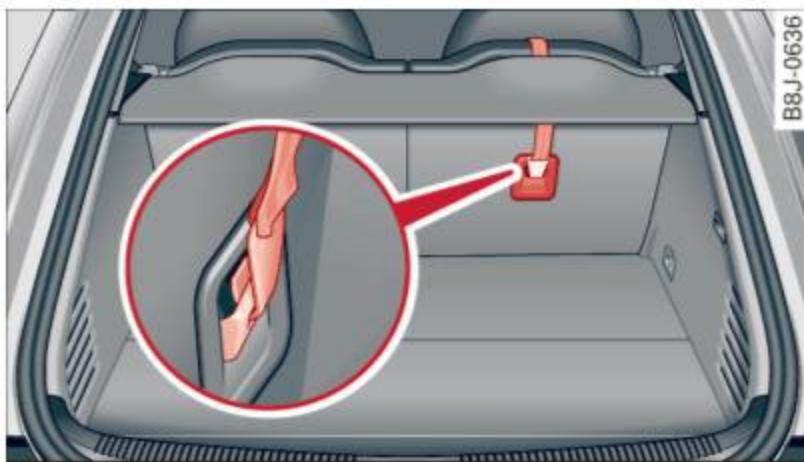

Fig. 125 Tether strap: proper routing and mounting

### Installing the tether strap

- ▶ Release or deploy the tether strap on the child restraint according to the child restraint manufacturer's instructions.
- ▶ Guide the upper tether strap into the rear cargo area ⇒ *fig. 125*.
- ▶ Slide the tether strap hook over the anchor bracket.
- ▶ Pull on the tether strap hook so that the spring catch of the hook engages.
- ▶ Tighten the tether strap firmly following the child restraint manufacturer's instructions.

### Releasing the tether strap

- ▶ Loosen the tension following the child restraint manufacturer's instructions.
- ▶ Depress the spring catch on the hook and release it from the anchorage.

#### Note

If you leave the child restraint with the tether strap firmly installed for several days, this could leave a mark on the upholstery on the seat cushion and backrest in the area where the tether strap was installed. The upholstery would also be permanently stretched around the tether strap. This applies especially to leather seats.

### Using tether straps on rearward-facing child restraints

Currently, few rear-facing child restraint systems come with a tether. Please read and heed the child restraint system manufacturer's instructions carefully to determine how to properly install the tether.

#### WARNING

A child in a rearward-facing child safety seat installed on the front passenger seat will be seriously injured and can be killed if the front airbag inflates - even with an Advanced Airbag System.

- The inflating airbag will hit the child safety seat or infant carrier with great force and will smash the child safety seat and child against the backrest, or door.
- A tight tether or other strap on a rearward-facing child restraint attached to the front passenger seat can put too much pressure on the weight-mat in the seat and register a heavier weight in the Advanced Airbag System. The heavier weight registered can make the system work as though an adult were on the seat and deploy the Advanced Airbag when it must be suppressed causing serious or even fatal injury to the child.

– If you must install a rearward facing child safety seat on the front passenger seat because of exceptional circumstances and the **PASSENGER AIR BAG OFF** light does not come on and stay on, immediately install the rear-facing child safety seat in a rear seating position and have the airbag system inspected by your Audi dealer.

## Additional Information

### Sources of information about child restraints and their use

There are a number of sources of additional information about child restraint selection, installation and use:

NHTSA advises that the best child safety seat is the one that fits your child and fits in your vehicle, and that you will use correctly and consistently.

Try before you buy!

#### **U.S National Highway Traffic Safety Administration**

Tel.: 1-888-327-4236 (TTY: 1-800-424-9153)  
www.nhtsa.gov

#### **National SAFE KIDS Campaign**

Tel.: (202) 662-0600  
www.safekids.org

#### **Safety BeltSafe U.S.A**

Tel.: (800) 745-SAFE (English)  
Tel.: (800) 747-SANO (Spanish)  
www.carseat.org

#### **Transport Canada Information Centre**

Tel.: 1 (800) 333-0371 or call  
1 (613) 998-8616 if you are in the Ottawa area  
<http://www.tc.gc.ca/eng/roadsafety/menu.htm>

#### **Audi Customer Relations**

Tel.: (800) 822-2834

## Intelligent technology

### Notice about data recorded by vehicle control modules

Your vehicle is not equipped with an Event Data Recorder (EDR), installed by some manufacturers for the express purpose of capturing data for retrieval after an accident or crash event. EDR's are sometimes called "crash recorders".

Some state laws restrict the retrieval or downloading of data stored by EDR's that were installed in a vehicle for the express purpose of retrieving data after an accident or crash event without the owner's consent.

Although your vehicle is not equipped with an EDR, it is equipped with a number of electronic control modules for various vehicle systems such as, for example, engine function, emission control, as well as for the airbags and safety belts.

These electronic control modules also record vehicle-related data during normal vehicle operation for diagnostic and repair purposes. The recording capacity of the electronic control modules is limited to data (no sound is recorded) and only a small amount of data is actually recorded over a very limited period of time and stored when a system fault or other condition is sensed by a control unit. Some of the data then stored may relate to vehicle speed, direction, braking as well as restraint system use and performance in the event of a crash or other condition. Stored data can only be read and downloaded with special equipment.

### Electronic Stabilization Control (ESC)

#### Description

ESC helps to improve road holding and vehicle dynamics to help reduce the probability of skidding and loss of vehicle control. It works only when the engine is running. ESC detects

certain difficult driving situations, including when the vehicle is beginning to spin (yaw) out of control and helps you to get the vehicle back under control by selectively braking the wheels, and/or reducing engine power and providing steering assistance to help hold the vehicle on the driver's intended course. The indicator light  in the instrument cluster blinks when ESC is taking action to help you control the vehicle.

ESC has limitations. It is important to remember that ESC cannot overcome the laws of physics. It will not always be able to help out under all conditions you may come up against. For example, ESC may not always be able to help you master situations where there is a sudden change in the coefficient of friction of the road surface. When there is a section of dry road that is suddenly covered with water, slush or snow, ESC cannot perform the same way it would on the dry surface. If the vehicle hydroplanes (rides on a cushion of water instead of the road surface), ESC will not be able to help you steer the vehicle because contact with the pavement has been interrupted and the vehicle cannot be braked or steered. During fast cornering, particularly on winding roads, ESC cannot always deal as effectively with difficult driving situations as at lower speeds.

Always adjust your speed and driving style to road, traffic and weather conditions. ESC cannot override the vehicle's physical limits, increase the available traction, or keep a vehicle on the road if road departure is a result of driver inattention. Instead, ESC improves the possibility of keeping the vehicle under control and on the road during extreme maneuvers by using the driver's steering inputs to help keep the vehicle going in the intended direction. If you are traveling at a speed that causes you to run off the road before ESC can provide any assistance, you may not experience the benefits of ESC.

ESC includes and/or works together with the anti-lock brake system (ABS), brake assist system and anti-slip regulation (ASR). ESC is

switched on all the time. In certain situations when you need less traction, you can switch off ESC by pressing the button . Be sure to switch ESC on again when you no longer need less traction.

### Anti-lock braking system (ABS)

ABS prevents the wheels from locking up when braking. The vehicle can still be steered even during hard braking. Apply steady pressure to the brake pedal. Do not pump the pedal. A pulsing in the brake pedal indicates that the system is helping you to brake the vehicle.

### Brake assist system

The brake assist system can decrease braking distance. It increases braking power when the driver presses the brake pedal quickly in emergency situations. You must press and hold the brake pedal until the situation is over.

### Anti-slip regulation (ASR)

ASR reduces engine power when the drive wheels begin to spin and adapts the force to the road conditions. This makes it easier to start, accelerate and drive up hills.

### Electronic differential lock (EDL)

The EDL brakes wheels that are spinning and transfers the drive power to the other drive wheel or wheels if the vehicle is equipped with all-wheel drive\*. This function is available up to about 60 mph (100 km/h).

In extreme cases, EDL automatically switches off to help keep the brake on the braked wheel from overheating. EDL will switch on again automatically when conditions have returned to normal.



#### WARNING

- ESC, ABS, ASR and EDL cannot overcome the laws of physics. This is especially important on slippery or wet roads. If the systems begin acting to stabilize your vehicle, you should immediately change your speed to match the road and traffic conditions. Do not let the increased safety provided by these systems tempt you

to take risks. Doing so will increase the risk of a loss of vehicle control, collision and serious personal injuries.

- Always adapt your speed to road, traffic and weather conditions. The risk of losing control of the vehicle increases when driving too fast, especially through curves and on slippery or wet roads, and when driving too close to vehicles up ahead. ESC, ABS, the brake assist system, EDL and ASR cannot prevent collisions.
- Always accelerate with special care on even, smooth surfaces such as those that are wet or covered with ice and snow. The drive wheels can spin even with these assistance systems that cannot always help to reduce the risk of loss of vehicle control.

#### Tips

- ABS and ASR only work correctly when all four wheels are equipped with identical tires. Different tire sizes can lead to a reduction in engine power.
- You may hear noises when the systems described are working.
- If the indicator light  or **ABS** (USA models)/ (Canada models) appears, there may be a malfunction ⇒ page 18, ⇒ page 17.

#### TT/TTS: Switching on/off

Applies to vehicles: TT Coupe and TTS Coupe

*ESC turns on automatically when you start the engine.*





Fig. 126 Center console: ESC OFF button

### Switching ESC off (sport mode)

In certain situations, it might make sense to allow some slip. For example:

- Rocking the vehicle to free it when it is stuck
- Driving in deep snow or on loose ground
- Driving with snow chains

Press the  button. The ESC indicator light  turns on and **Stabilization program off** appears in the display. ASR deactivates completely and the stabilization effects from the ESC system are limited.

### Switching on

Press the  button again. The message **Stabilization program on** appears briefly in the display.

#### WARNING

Only switch ESC sport mode on when your driving abilities and the traffic situation permit. Please note that the driving wheels can spin and the vehicle can break away in ESC sport mode, especially when the road is slippery.

#### Tips

If there are faults in the rear spoiler system or in Audi magnetic ride, it may not be possible to activate ESC sport mode or normal mode may activate again automatically.

### TT RS: Switching on/off

Applies to vehicles: TT RS Coupe

*ESC turns on automatically when you start the engine.*





Fig. 127 Center console: ESC OFF button



### ESC sport mode

In certain situations, it might make sense to allow some slip. For example:

- Rocking the vehicle to free it when it is stuck
- Driving in deep snow or on loose ground
- Driving with snow chains

Press the  button briefly ⇒ fig. 127. The  indicator light turns on and **Sport control Warning! Restricted stability** appears in the driver information system display. Driving stability is limited in sport mode.

### Switching ESC off

Press and hold the  button for three seconds. The ESC indicator light  turns on and **Stabilization program off** appears in the display. ASR is also switched off when ESC is switched off.

### Switching on

Press the  button again. The message **Stabilization program on** appears briefly in the display.

#### WARNING

You should only switch the ESC off if your driving ability and the traffic situation allow. This could increase the risk of slipping.

- The stabilizing function is limited in ESC sport mode. The driving wheels could spin and the vehicle could swerve, especially on slick or slippery road surfaces.
- There is no vehicle stabilization when ESC is switched off.

#### Tips

If there is a malfunction in the retractable rear spoiler\* or the Audi magnetic ride\*, it may not be possible to activate ESC sport mode or normal mode may activate again automatically.

## Rear spoiler

Applies to vehicles: with retractable rear spoiler

*The rear spoiler improves vehicle handling and enhances driver control.*



Fig. 128 Switch for rear spoiler

The rear spoiler deploys and retracts. Spoiler operation can be set for automatic or manual operation.

### Automatic mode (normal operation)

- Automatic deployment: At a speed of about 75 mph (120 km/h), the rear spoiler deploys automatically.
- Automatic retraction: When speed drops below about 50 mph (80 km/h), the rear spoiler retracts automatically.

### Manual mode

- Manual deployment: Tapping briefly on the switch ⇒ *fig. 128* deploys the rear spoiler.
- Manual retraction: At speeds up to about 10 mph (20 km/h), retract the rear spoiler by pressing and holding the switch ⇒ *fig. 128*. At speeds between 10 mph (20 km/h) and 75 mph (120 km/h), retract the rear spoiler by tapping on the switch ⇒ *fig. 128*.

### WARNING

Driving at higher speeds without the rear spoiler deployed can impair handling characteristics, making the vehicle harder to control.

- Always make sure that the spoiler is deployed when driving at speeds over 85 mph (140 km/h). If the rear spoiler warning/indicator light in the instru-

ment cluster comes on, the rear spoiler may not have deployed.

- Never drive at speeds higher than 85 mph (140 km/h) if the spoiler is not deployed. Have the spoiler inspected as soon as possible by an authorized Audi dealer or qualified workshop.
- Always obey speed limits and other traffic laws.

### WARNING

Improper operation of the rear spoiler can cause crushing injuries.

- Always make sure that nobody, especially children, is in the way when the rear spoiler is deployed or retracted.

### Note

Never push the vehicle or apply force to the rear spoiler – it could be damaged.

### Tips

Clean the spoiler compartment every 2 to 3 months. The spoiler compartment must always be free of ice, snow, leaves or other debris.

## Braking

### General information

*What affects braking efficiency?*

### Operating conditions and driving habits

The brakes on today's automobiles are still subject to wear, depending largely on operating conditions and driving habits ⇒ . On vehicles that are either driven mostly in stop-and-go city traffic or are driven hard, the brake pads should be checked by your authorized Audi dealer more often than specified in the **Warranty & Maintenance booklet**. Failure to have your brake pads inspected can result in reduced brake performance.

On steep slopes, you should use the braking effect of the engine. This way, you prevent unnecessary wear on the brake system. If you must use your brakes, do not hold the brakes ▶

down continuously. Pump the brakes at intervals.

Noises may occur when braking depending on the speed, braking force and outside conditions such as temperature and humidity.

### Moisture or road salt

Under certain conditions, for example, when driving through water or very heavy rain, or even after washing your vehicle, the braking effect can be reduced due to moisture (or in freezing conditions ice) on the brake pads. A few cautious brake applications should dry off the brake pads or remove any ice coatings.

The effectiveness of the brakes can be reduced when the vehicle is driven on a salt-covered road and the brakes are not used. Likewise, you clean off accumulated salt coating from brake discs and pads with a few cautious applications of the brake ⇒ ⚠.

### Corrosion

There may be a tendency for dirt to build up on the brake pads and corrosion to form on the discs if the car is not driven regularly or only for short trips with little use of the brakes.

If the brakes are not used frequently, or if corrosion has formed on the discs, it is advisable to clean off the pads and discs by braking firmly a few times from a moderately high speed ⇒ ⚠.

### Faults in the brake system

If you should notice a *sudden* increase in brake pedal travel, then one of the two brake circuits may have failed ⇒ ⚠.

### Low brake fluid level

Malfunctions can occur in the brake system if the brake fluid level is too low. The brake fluid level is monitored electronically.

### Brake booster

The brake booster increases the pressure that you generate with the brake pedal. It works only when the engine is running ⇒ ⚠

### Brake lining wear status

Brake lining wear may be checked by visual inspection of the condition of the brake pads through the openings in the wheel. If necessary, the wheel may be removed for this inspection ⇒ *page 224, What should I be aware of when changing a tire?*

#### **WARNING**

- You should perform braking maneuvers for the purpose of cleaning the brake system only if road conditions permit. Other road users must not be put at risk - you may cause an accident!
- Before descending a steep grade, reduce speed and shift transmission into a lower gear or lower driving range. Do not ride the brakes or hold the pedal down too long or too often. This could cause the brakes to get hot and diminish braking efficiency.
- Do not “ride the brakes” by resting your foot on the pedal when you do not intend to brake. This may cause the brakes to overheat, premature wear and increased stopping distance.
- Under certain climatic and operating conditions such as passing through water, driving in heavy rain or after washing the vehicle, the effectiveness of the brakes can be reduced. In winter, ice can accumulate on the brake pads, linings, discs and drums. Carefully apply brakes for a test. Brakes will dry and ice coatings will be cleaned off after a few careful brake applications.
- Driving for an extended period of time on salt-covered roads without using your brakes can also affect braking efficiency. Clean off accumulated salt coating from brake discs and pads with a few cautious brake applications.
- If you damage the front spoiler, or if you install a different spoiler, be sure the air flow to the front brakes is not obstructed. Otherwise the brake system could

overheat reducing the effectiveness of the entire brake system.

- Failure of one brake circuit will impair the braking capability resulting in an increased stopping distance. Avoid driving the vehicle and have it towed to the nearest Audi dealer or qualified workshop.
- Never let the vehicle roll to a stop with the engine shut off.
- If the brake booster is not working, for example when towing your vehicle, or because the brake booster has somehow been damaged, the brake pedal must be pressed considerably harder to make up for the lack of booster assistance.

## Electro-mechanical power assist

*The electro-mechanical power assist helps the driver when steering.*

The degree of power assist is *electronically* matched to vehicle speed.

The power steering system assists the driver so that he can steer the vehicle with reduced physical effort.



Power steering will not work if the engine is off. As a result, the steering wheel will be hard to turn.

### WARNING

If the system develops a problem, you must seek qualified professional assistance.

### Note

If there is an electronic malfunction, *servotronic* will still function like a conventional power steering system, providing a constant steering support force that is no longer proportionate to the vehicle speed. This is most noticeable when turning the steering wheel at low speeds (for example when parking), - more effort will be required than usual.

- Be aware of the different than usual steering response and adjust your steering force accordingly.
- Have the problem checked and set right by an authorized Audi dealer as soon as possible.
- If a steering malfunction occurs, this is signaled with the  or  indicator lights and a warning tone, see .

### Tips

- If the power steering system should fail, or if the engine is not running (for example, while being towed), you will still be able to steer the vehicle. However, more effort will be required to do so.
- If the power steering system is not functioning properly, contact your authorized Audi dealer immediately.

## Driving with your quattro®

Applies to vehicles: with all-wheel drive

*With all-wheel drive, all four wheels are driven.*

### General information

With all-wheel drive, power is distributed to all four wheels. This happens automatically depending on your driving style and the road conditions at the time. See also ⇒ *page 150*.

The all-wheel drive concept is designed for high engine power. Your vehicle is exceptionally powerful and has excellent driving characteristics both under normal driving conditions and on snow and ice. Always read and follow safety precautions ⇒ .

### Winter tires

When driving in the winter, your vehicle with all-wheel drive has an advantage, even with regular tires. In winter road conditions it may be advisable to mount winter tires (or all-season tires) for improved driveability and braking: these tires must be mounted on **all four wheels**. See also ⇒ *page 211, Winter tires*. ▶

## Snow chains

Where tire chains are mandatory on certain roads, this normally also applies to vehicles with all-wheel drive ⇒ *page 212, Snow chains*.

## Replacing wheels/tires

Vehicles with all-wheel drive must always have tires of the same size. Also avoid tires with different tread depths. For details see *page 207, New tires and replacing tires and wheels*.

## Off-Road driving?

Your Audi does not have enough ground clearance to be used as an off-road vehicle. It is therefore best to avoid rough tracks and uneven terrain as much as possible. Also refer to ⇒ *page 160*.



### WARNING

Always adjust your driving to road and traffic conditions. Do not let the extra safety afforded by all-wheel drive tempt you into taking extra risks.

- Although the all-wheel drive is very effective, always remember that braking capacity is limited by tire traction. You should therefore not drive at excessive speeds on icy or slippery road surfaces.
- On wet road surfaces, be careful not to drive too fast because the front wheels could begin to slide on top of the water (aquaplaning). If this should occur, you will have no warning from a sudden increase in engine speed as with a front-wheel drive vehicle. Always drive at speeds which are suited to the road conditions. – risk of crash.

## Energy management

### Starting ability is optimized

*Energy management controls the distribution of electrical energy and thus optimizes the availability of electrical energy for starting the engine.*

If a vehicle with a conventional energy system is not driven for a long period of time, the battery is discharged by idling current consumers (e.g. immobilizer). In certain circumstances it can result in there being insufficient energy available to start the engine.

Intelligent energy management in your vehicle handles the distribution of electrical energy. Starting ability is markedly improved and the life of the battery is extended.

Basically, energy management consists of **battery diagnosis, idling current management and dynamic energy management**.

### Battery diagnosis

Battery diagnosis continuously determines the state of the battery. Sensors determine battery voltage, battery current and battery temperature. This determines the current state of charge and the power of the battery.

### Idling current management

Idling current management reduces energy consumption while the vehicle is standing. With the ignition switched off, it controls the energy supply to the various electrical components. Data from battery diagnosis is considered.

Depending on the battery's state of charge, individual consumers are gradually turned off to prevent excessive discharge of the battery and thus maintain starting capability.

### Dynamic energy management

While the vehicle is being driven, dynamic energy management distributes the energy generated according to the needs of the individual components. It regulates consumption, so that more electrical energy is not being used ►

than is being generated and ensures an optimal state of charge for the battery.

### Tips

- But even energy management cannot negate the limits of physics. Consider that the power and life of a battery are limited.
- If starting ability is threatened, you are informed by a warning ⇒ *page 157, Driver notification in the instrument cluster display.*

### What you should know

*The highest priority is given to maintaining starting capability.*

The battery is severely taxed in short-distance driving, in city traffic and during the cold time of year. Abundant electrical energy is required, but only a little is generated. It is also critical if the engine is not running and electrical components are turned on. In this instance energy is being consumed but none is being generated.

It is in precisely these situations that you will notice energy management actively regulating the distribution of energy.

#### Vehicle stands for an extended period

If you do not drive your vehicle over a period of several days or weeks, electrical components are gradually cut back or switched off. This reduces energy consumption and maintains starting capability over a longer period.

Take into consideration that when you unlock your vehicle, some convenience functions, such as the remote key or power seat adjustment, may not be available. The convenience functions will be available again when you turn on the ignition and start the engine.

#### With the engine turned off

If you listen to the radio, for example, with the engine turned off, the battery is being discharged.

If starting capability is jeopardized due to energy consumption, a message appears in the driver information display.

You have to start the engine to charge the battery.

#### With the engine running

Although electrical energy is generated when the vehicle is being driven, the battery can become discharged. This happens mostly when little energy is being generated and a great deal consumed and the battery's state of charge is not optimal.

To bring the energy balance back into equilibrium, consumers which require especially large amounts of energy are temporarily cut back or switched off. Heating systems in particular require a great deal of energy. If you notice, for example, that the heated seats\* or the heated rear window are not heating, they have been temporarily cut back or switched off. These systems will be available again as soon as the energy balance has been restored.

You will also notice that engine idle speed has been increased slightly. This is normal and not a cause for concern. By increasing engine idle speed the additional energy required is generated and the battery is charged.

### Driver notification in the instrument cluster display

If battery power drops into the range where it can limit the ability of the engine to start, this is shown in the instrument cluster display with the following driver message:

#### Low battery charge: battery will be charged while driving

This notification reminds you that the starting capability of the engine may be limited. As soon as you start driving again, the battery will be recharged and the notification will go out.

**Driver notification appears and goes out again**

If this driver notification appears after the ignition is turned on or while driving and it goes out again after a while, the battery has been adequately recharged.

**Driver notification appears and does not go out again**

If this driver notification appears after the ignition is turned on or while driving and does not go out again, the battery's state of charge is not in the optimal range. Starting ability is restricted. Have the battery checked as soon as possible by an authorized Audi dealer or qualified workshop.

## Driving and environment

### The first 1,000 miles (1,500 km) and afterwards

#### New engine

The engine needs to be run-in during the first 1,000 miles (1,500 km).

#### For the first 600 miles (1,000 kilometres):

- ▶ Do not use full throttle.
- ▶ Do not drive at engine speeds that are more than 2/3 of the maximum permitted RPM.
- ▶ Avoid high engine speeds.

#### From 600 to 1,000 miles (1,000 to 1,500 kilometres):

- ▶ Speeds can *gradually* be increased to the maximum permissible road or engine speed.

#### During and after break-in period

- ▶ Do not rev the engine up to high speeds when it is cold. This applies whether the transmission is in N (Neutral) or in gear.

#### After the break-in period

- ▶ Do not exceed maximum engine speed under any circumstances.
- ▶ Upshift into the next higher gear *before* reaching the red area at the end of the tachometer scale ⇒ *page 10*.

During the first few hours of driving, the engine's internal friction is higher than later when all the moving parts have been broken in. How well this break-in process is done depends to a considerable extent on the way the vehicle is driven during the first 1,000 miles (1,500 kilometres).

#### Note

Extremely high engine speeds are automatically reduced. However, these RPM-

limits were programmed for an engine well run-in, not a new engine.



#### For the sake of the environment

Do not drive with unnecessarily high engine speeds - upshifting early saves fuel, reduces noise and protects the environment.

#### New tires

If your vehicle is running on new tires, drive particularly careful for the first 350 miles (500 kilometres) after fitting.



#### WARNING

New tires tend to be slippery and must also be "broken-in". Be sure to remember this during the first 350 miles (500 kilometres). Brake gently. Avoid following closely behind other vehicles or other situations that might require sudden, hard braking.

#### New brake pads

Remember that new brake pads do not have a full braking effect during the first 250 miles (400 kilometres) after they are installed.

New brake pads have to be "burnished in" before they have optimal grab ⇒ .

During the break-in period, you should avoid putting severe loads on the brakes. Severe loads include, for example, sudden hard braking, in particular at very high speeds or, for example, on mountain passes.



#### WARNING

Until they develop the maximum "bite" for best stopping power, the surfaces on new brake pads require some "breaking-in" during the initial 100 to 150 miles (150 to 200 kilometres) of normal city driving. You can compensate for this by pressing the brake pedal more firmly. This applies whenever new pads are installed.

## Avoid damaging the vehicle

When you are driving on poor roads, or over curbs, steep ramps, etc., make certain that low-lying parts such as spoilers and exhaust system parts do not bottom out and get damaged.

This is especially true for vehicles with low-slung chassis (sports chassis) and fully loaded vehicles.

## Driving through water on roads

Note the following to avoid vehicle damage when driving through water, for example on flooded roads:

- The water must not be any higher than the bottom of the vehicle body.
- Do not drive faster than walking speed.

### WARNING

After driving through water, mud, slush, etc., the brakes may be slow to take effect because of wet brake rotors and pads. Dry the brakes first by braking carefully to restore the full braking effect.

### Note

Vehicle components such as the engine, transmission, suspension or electrical system can be severely damaged by driving through water.

### Tips

- Check the depth of the water before driving through it.
- Do not stop the vehicle, drive in reverse or switch the engine off when driving through water.
- Keep in mind that oncoming vehicles may create waves that raise the water level and make it too deep for your vehicle to drive through safely.
- Avoid driving through salt water because it can cause corrosion.

## Catalytic converter

*It is very important that your emission control system (catalytic converter) is functioning properly to ensure that your vehicle is running in an environmentally sound manner.*

- ▶ Always use lead-free gasoline ⇒ *page 176, Fuel supply.*
- ▶ Never run the tank down all the way to empty.
- ▶ Never put too much motor oil in your engine ⇒ *page 185, Adding engine oil* .
- ▶ Never try to push- or tow-start your vehicle.

The catalytic converter is an efficient “clean-up” device built into the exhaust system of the vehicle. The catalytic converter burns many of the pollutants in the exhaust gas before they are released into the atmosphere.

The exclusive use of unleaded fuel is critically important for the life of the catalytic converter and proper functioning of the engine.

### WARNING

- Do not park or operate the vehicle in areas where the hot exhaust system may come in contact with dry grass, brush, fuel spill or other material which can cause a fire.
- Do not apply additional undercoating or rustproofing on or near the exhaust manifold, exhaust pipes, catalytic converter or heat shields. During driving, the substance used for undercoating could overheat and cause a fire.

### Note

- Be aware that just one tank filling with **leaded** fuel will already seriously degrade the performance of the catalytic converter.
- Do not exceed the correct engine oil level ⇒ *page 185.*
- Do not drive until the fuel tank becomes completely empty. The engine could misfire. Unburned fuel could also get into

the exhaust system and this could cause the catalytic converter to overheat.

- Do not turn off the ignition while the vehicle is moving.
- Do not continue to operate your vehicle under these conditions, as otherwise fuel can reach the catalytic converter. This could result in overheating of the converter, requiring its replacement.
- To assure efficient operation of the Emission Control System:
  - Have your vehicle maintained properly and in accordance with the service recommendations in your Warranty & Maintenance booklet.
  - Lack of proper maintenance as well as improper use of the vehicle will impair the function of the emission control system and could lead to damage.



### For the sake of the environment

Even when the Emission Control System is operating properly, the exhaust gas can have a sulfur-like exhaust gas smell under some operating states. This depends on the sulfur content of the fuel being used. Using a different brand of fuel may help, or filling the tank with lead-free super grade gasoline.

## Operate your vehicle economically and minimize pollution

### General

*Your personal style of driving will determine the economy of your vehicle, as well as exhaust and noise levels.*

Fuel economy, environmental impact, and wear on your engine, brakes and tires largely depend on three factors:

- your personal driving style
- operating conditions
- technical limitations

If you anticipate what you need to do next and drive economically, you can easily cut your

fuel consumption by 10-15 percent. This section will give you some tips on how you can help the environment and your pocketbook.

### Tips

The consumption estimates as published by ENVIRONMENTAL PROTECTION AGENCY (EPA) and Transport Canada may not correspond to your actual consumption on the road, which will vary depending upon vehicle load and speed, road and weather conditions, trip length, etc.

### Drive smoothly and keep a lookout ahead

*Vehicles use the most fuel when they are accelerating.*

Avoid unnecessary accelerating and braking.

Vehicles use the most fuel when they are accelerating. If you anticipate what is going to happen next, you will need to brake less and, thus, accelerate less. Let the vehicle coast whenever possible - for example when you see that the next traffic light is red.

### Avoid full throttle

*Driving at moderate speeds saves fuel and improves your mileage.*

- ▶ Try and keep well below your car's maximum speed.

Accelerating gently reduces fuel consumption, engine wear, and does not disturb the environment.

Fuel consumption, exhaust emissions and engine noise increase disproportionately at high speeds. If you drive at approximately three quarters of top speed, fuel consumption will be reduced by one half. Never drive faster than the posted speed limit and weather conditions permit.

### Reducing unnecessary idling

*Even when your car is just idling it burns up fuel.*

- ▶ Shut the engine off when you are not driving the vehicle.
- ▶ Do not warm up the vehicle by letting the engine run at idle.

It makes sense to shut off the engine in traffic jams, when waiting for trains to pass at railroad crossings, or at traffic lights that have long waits on red. Turning the engine off for just 30-40 seconds saves more fuel than is burned starting the engine again.

It takes a long time for the engine to warm up fully when it is running at idle. However, wear and noxious emissions are especially high when the engine is warming up. So you should drive away as soon as you start the engine and avoid running at high RPMs while the engine is still warming up.

#### Note

Do not leave engine idling unattended after starting. If warning lights should come on to indicate improper operation, they would go unheeded. Extended idling also produces heat, which could result in overheating or other damage to the vehicle or other property.

### Regular maintenance

*A badly tuned engine unnecessarily wastes a lot of fuel.*

- ▶ Have your vehicle serviced at regular intervals.

By having your vehicle regularly serviced by an Audi dealer helps to ensure that it runs properly and economically. The condition of your vehicle not only affects its safety and ability to hold its value, it also affects **fuel consumption**.

**Check your oil each time you fill your tank.**

The amount of oil used is related to engine load and speed.

It is normal for the oil consumption of a new engine to reach its lowest value after a certain mileage has been driven.

You must drive your vehicle about 3,000 miles (5,000 kilometres) before you can properly assess oil consumption.

This also applies to fuel consumption and engine output.

#### Note

- Have your vehicle maintained properly and in accordance with the service recommendations in your Warranty & Maintenance booklet. Lack of proper maintenance as well as improper use of the vehicle will impair the function of the emission control system and could lead to damage.
- Do not alter or remove any component of the Emission Control System unless approved by the manufacturer.
- Do not alter or remove any device, such as heat shields, switches, ignition wires, valves, which are designed to protect your vehicle's Emission Control System and other important vehicle components.

### Fewer short trips

*Fuel consumption will always be relatively high on short trips.*

- ▶ Try to avoid driving short distances with a cold engine.

The engine and catalytic converter have to reach their optimal **operating temperature** to reduce fuel consumption and noxious emissions effectively.

- Just after starting, a cold engine in a mid-size car burns the fuel at a poor rate of 6-8 miles per gallon (30-40 l/100km). Half a mile down the road, the mileage improves to 12 MPG (20 l/100 km). It will take the

engine no less than *two and a half miles (4 km)* of driving to warm up to its proper operating temperature and operate at an economic mileage. This explains why taking the car for short trips is a rather wasteful convenience.

- The **outside temperature** is also critical in this regard. Your car consumes more fuel in the winter than in the summer.

## Trailer towing

### General information

*Your Audi TT Coupe is not designed to tow a trailer.*

Towing a trailer with your Audi TT Coupe is not recommended and can cause damage to the car. Damaged caused by towing a trailer is not covered by your Audi Warranty.

## Cleaning and protection

### General information

*Regular care preserves vehicle value.*

Any automobile is exposed to industrial fumes, corrosive road salt, etc. A well cared for Audi can look like new many years after purchase. Regular and correct care will contribute to maintaining the beauty and value of your Audi.

**Furthermore, good care may be a condition for substantiating a warranty claim should corrosion damage or paint defects occur.**

Your authorized Audi dealer has a variety of **dedicated vehicle-care products** and can advise which ones to use for cleaning the exterior and interior of your vehicle.

Whether you use products recommended by Audi or other commercially available cleaning agents, please make sure you apply them correctly.

#### WARNING

- Cleaning agents may be poisonous. Keep them out of the reach of children.
- Heed all caution labels.
- Always read directions on the container before using any product. Follow the directions carefully.
- Most chemical cleaners are concentrated and have to be diluted.
- Use spot removing fluids only in well ventilated areas.
- Do not use gasoline, kerosene, diesel fuel, nail polish remover or other volatile fluids. They may be toxic, flammable or hazardous in other ways. Do not wash, wax or dry the vehicle with the ignition on or the engine running.
- Do not clean the undersides of chassis, fenders, wheel covers, etc. without protecting your hands and arms. You may cut yourself on sharp-edged metal parts.

- Moisture and ice on brakes may impair braking efficiency ⇒ *page 153, General information*. Test the brakes carefully each time you wash the vehicle.



#### For the sake of the environment

Select only environmentally friendly cleaning products. Leftover cleaning products should not be disposed of in the household waste.

## Care of exterior

### Washing

*Frequent washing protects the vehicle.*

The best protection against environmental influences is *frequent* washing and waxing. How often this is required depends on:

- How much the vehicle is used
- Where the vehicle is parked (garage, in the open under trees, etc.)
- The seasonal and weather conditions
- Environmental influences

The longer bird droppings, insects, tree resin, road and industrial grime, tar, soot, road salt and other materials remain on the vehicle paint, the more lasting their destructive effects will be.

High temperatures, as from exposure to intense sunlight, intensify the corrosive effect particularly when humidity is high as well.

Under certain circumstances, **weekly** washing may be necessary. Under other conditions, a monthly washing and waxing may be adequate.

After the winter, the underside of the vehicle should be thoroughly washed preferably in a professional car wash.



#### WARNING

Always read and heed all WARNINGS and the information ⇒ *page 164*.

## Automatic car wash

*The vehicle can be washed in almost any modern automatic car wash.*

The vehicle paint is so durable that the vehicle can normally be washed without problems in an automatic car wash. However, the effect on the paint depends to a large extent on the design of the facility, the filtering of the wash water, the type of wash and care material, etc. If the paint has a dull appearance after going through the car wash or is scratched, bring this to the attention of the operator immediately. If necessary, use a different car wash.

Before going through a car wash, be sure to take the usual precautions such as closing the windows. Remove antenna if applicable.

If you have installed additional accessories on the vehicle - such as spoilers, etc. - it is best to ask the car wash operator if these should be removed.

### WARNING

Always read and heed all WARNINGS and the information ⇨ *page 164*.

### Note

- Fold the exterior mirrors - flat there is a risk of damaging the exterior mirrors. Power folding exterior mirrors must not be folded in or out by hand. Use the power function!
- Compare the track of your vehicle with the distance between the guide rails of the facility - there is a risk of damage to the wheels and tires.
- Compare the width of your vehicle with the width of the tunnel at the facility.

## Washing the vehicle by hand

*A lot of water is needed when washing a vehicle by hand.*

- ▶ Before you start washing, make sure you have read and understood the WARNINGS ⇨  in *General information on page 164*.

- ▶ First soak all dried dirt until it is soft, then rinse it off.
- ▶ As you clean your vehicle, start with the roof and work your way down to the bottom, using a sponge, a sponge glove or a clean brush.
- ▶ Rinse the sponge or the sponge glove often, flushing it clean each time.
- ▶ Use special car shampoo only for very persistent dirt.
- ▶ Rinse the car thoroughly with water.
- ▶ Use a chamois leather to gently wipe the exterior dry.

Use a separate sponge for cleaning the wheels, door sills and other regions exposed to road dirt. In this way, you will not scratch the paint with coarse particles imbedded in the sponge the next time you wash the car.

### WARNING

- Wash your vehicle only when the ignition is switched off to reduce the risk of a crash.
- Always read and heed all WARNINGS and other information ⇨ *page 164*.

### Note

- Never try to remove dirt, mud or dust if the surface of the vehicle is dry. Never use a dry cloth or sponge, since this could scratch your vehicle's paint or windows.
- Never wash your car in bright sunlight. Drops of water act as magnifying lenses and may damage your paint.
- When you wash your car in the winter: if you rinse your vehicle with a hose, be careful not to aim the stream of water directly at locks, or at door or hatch openings - they can freeze shut.
- Never use sponges designed to remove insects, or any kitchen scouring sponges or similar products. They can damage your paint finish.
- Never use a dry cloth or sponge to clean the headlights. Only use wet cloths or

sponges to prevent scratches. It is best to use soapy water.

- You should remove debris (such as insects) from the headlight lenses on a regular basis, for example when refueling your vehicle.



### **For the sake of the environment**

Only wash the vehicle in facilities specially designed for that purpose. This will reduce the risk of dirty water contaminated with oil from entering the sewer system. In some areas, washing vehicles outside of these facilities is prohibited.

### **Washing your vehicle with a power washer**

*Cleaning the exterior of your car with a high-pressure power washer is safe as long as you observe a few simple rules.*

- ▶ Before using the power washer, make sure you have read and understood the WARNINGS ⇒  in *General information on page 164*.
- ▶ Always follow the operating instructions for the power washer.
- ▶ Make sure that the jet on the spray hose produces a “fan shaped spray”.
- ▶ Do *not* hold the spray nozzle *too close* to soft materials.

Keep a distance from soft materials such as rubber hoses or insulating material as well as sensors and camera lenses.

When cleaning the vehicle with a power washer *always* follow the operating instructions. This applies particularly to the operating pressure and the spraying distance. Do not point the spray directly at the seals around the side windows, around the doors, on the rear lid or on the sunroof\*. Likewise, do not point it directly at tires, rubber hoses, insulation material or sensors. Hold the spray nozzle at least 1.3 ft (0.4 m) away from the vehicle.

Do not use a high-pressure power washer to remove snow and ice.

Do not use a jet which sprays water in a direct stream or one that has a rotating jet.

Water temperature should not exceed 140 °F (60 °C).



### **WARNING**

Never wash tires with a jet that sprays water in a direct stream. This could cause invisible damage to the tires and weaken them, even if the spray is from a relatively long distance and for a short time. Damaged and weakened tires can fail and cause accidents and personal injury.



### **Note**

To avoid damaging your vehicle, always make sure that there is sufficient distance between the spray head and soft materials like rubber hoses, plastic parts and sound-deadening materials as well as sensors and camera lenses. Never aim the spray head at the same point for a long time. This also applies to cleaning headlights and painted bumpers. Remember: the closer the nozzle is to the surface of the material, the greater the stress on the material.

### **Caring for vehicles with matte finish paint**

Applies to vehicles: with matte finish paint

*Vehicles with matte finish paint require special care due to the characteristics of the paint.*

#### **Washing by hand**

To avoid damaging the paint when washing, first remove dust and large particles from your vehicle. Insects, grease spots and fingerprints are best removed with a **special cleaner for matte finish paint**.

Apply the product using a **microfiber cloth**. To avoid damaging the paint surface, do not use too much pressure. ►

Rinse the vehicle thoroughly with water. Clean the vehicle starting at the top and working toward the bottom using a **neutral shampoo** and a soft **microfiber cloth**. Stop frequently to rinse the cloth thoroughly.

Clean the wheels and sill panels last. Use a clean **sponge** on these areas.

Rinse the vehicle thoroughly again and let it air dry. If there are any water spots, they can be removed using a **leather cloth**.

Clean again with the **special cleaner for matte finish paint** if necessary.

### Removing stubborn dirt

**Bird droppings** or **tree sap** are best removed with plenty of water and a microfiber cloth.

You should rinse off **gasoline residue** immediately with plenty of water.

#### **WARNING**

- Wash your vehicle only when the ignition is switched off to reduce the risk of a crash.
- Always read and heed all WARNINGS and other information ⇨ *page 164*.

#### **Note**

- Do not treat vehicle parts painted with matte finish paint using polishing materials or hard wax. These products could cause damage to the appearance or surface that cannot be repaired.
- Never use protective wax. It can destroy the matte finish effect.
- Do not place any stickers or magnetic signs on vehicle parts painted with matte finish paint. The paint could be damaged when the stickers or magnets are removed.
- To prevent paint damage, do not wash the vehicle in direct sunlight.
- To prevent damage to the paint surface, do not use insect removal sponges, rough kitchen sponges or similar items.
- You should remove debris (such as insects) from the headlight lenses on a

regular basis, for example when refueling your vehicle. Only clean the headlights using a wet cloth or sponge, never a dry one. Cleaning with soapy water is recommended.

#### **Tips**

For more information on special cleaning products designed for matte finish paint, see your Audi dealer.

## Waxing and Polishing

### Waxing

A good wax coating protects the vehicle paint to a large extent against the environmental factors listed under ⇨ *page 164, Washing* and even against slight scratches.

You can use a liquid car wax to protect your paint as soon as one week after your vehicle has been delivered.

Even if you regularly use a **waxing** process in automatic car washes, we recommend that you manually apply a coat of wax to give the paint extra protection, particularly if water no longer beads on the clean paint.

Protect plastic body parts with car wax in the same way as the vehicle body.

During warm weather dead insects tend to collect on the front bumper and on the forward area of the hood. They are much easier to remove from paint that is waxed *often*.

### Polishing

Polish your vehicle only if the paint has lost its shine and the gloss cannot be brought back with wax.

If the polish used does not contain preservative compounds, the paint must be waxed afterwards.

#### **WARNING**

Always read and heed all WARNINGS and other information ⇨ *page 164*.

**!** **Note**

Do not use car wax on  
 – matte or anodized metal trim  
 – rubber or rubber-like trim.

**Trim strips**

*Metal trim needs special care.*

For environmental reasons, Audi fabricates the bright trim strips and trim pieces from pure chromium-free aluminum.

Dirt and marks on the trim strips should be removed with a **pH-balanced** cleaning agent (do not use a chrome cleaner). Audi dealers carry cleaning products which have been tested for use on your vehicle and are not harmful to the environment.

To avoid corrosion on the exterior trim strips, only a pH-balanced solution should be used for the windshield washer.

**!** **WARNING**

Always read and heed all WARNINGS and other information ⇒ *page 164.*

**Plastic and vinyl**

*Plastics needs special care.*

Use a clean, damp cloth or sponge to remove dust and light surface dirt. For other soil, use a lukewarm all-purpose cleaning solution or a mild saddle soap for vinyl trim. Remove water spots and soap traces with a clean, damp cloth or sponge. Use a clean, soft cloth to rub dry.

Grease, tar or oil stains can be removed with a clean cloth or sponge soaked with all-purpose cleaner or with a solvent designed especially to clean vinyl.

Occasionally apply a colorless vinyl or leather preservative to retain the material's luster and pliability.

**!** **WARNING**

Always read and heed all WARNINGS and the information ⇒ *page 164.*

**Aluminum trim**

Use only **neutral-pH** products to remove spots and deposits from aluminum surfaces. Chrome care products and alkaline cleaners will attack aluminum surfaces and can damage them over time.

**!** **WARNING**

Always read and heed all WARNINGS and the information ⇒ *page 164.*

**Touch-up paint**

*Minor paint damages should be touched up immediately.*

- ▶ Use either a touch-up paint stick or spray paint to cover minor scratches and nicks.

Your Audi dealer has touch-up paint for minor scratches and stone chips. Scratches should be touched up soon after they occur to prevent corrosion.

The number for the original vehicle paint can be found on the vehicle identification label ⇒ *page 238.*

**!** **WARNING**

Always read and heed all WARNINGS and the information ⇒ *page 164.*

**Windows**

*Clear vision to all sides.*

Clean all windows regularly to remove road film and carwash wax buildup.

- ▶ Remove snow from windows using a brush.
- ▶ Use a plastic ice scraper to remove ice from windows and mirrors.
- ▶ Remove other residue on the windows with a spray-on glass cleaner.

- ▶ Wipe the windows dry with a clean piece of cloth or kitchen paper towel.

The best way to remove snow from windows and mirrors is to use a brush. Use a non-abrasive **plastic ice scraper** - better still, a spray deicer - to remove **ice** from windows and mirrors.

The windows must not be cleaned with insect remover or wax since these can interfere with the function of the windshield wiper blades (chatter).

Oil, grease or silicone residue can be removed with **glass cleaner** or **silicone remover**. However, wax residue requires the use of a specially formulated solvent. Please contact your Audi dealer for advice on safe products for wax removal.

Windows should also be cleaned on the inside at regular intervals.

Never dry windows with the same chamois that you use to dry painted surfaces. Wax residue on the chamois can impair vision through the windows.

### WARNING

- The windshield must not be treated with water-repellent materials. They can increase glare under poor visibility conditions such as wetness, darkness, or when the sun is low on the horizon. In addition, they can cause the windshield wipers to chatter.
- Always read and heed all WARNINGS and other information ⇒ *page 164*.

### Note

- Never use warm or hot water to remove snow and ice from windows and mirrors. This could cause the glass to crack.
- To prevent damage to the wires of the rear defogger, do not place any adhesive stickers on the inside of the rear window over the wires.
- To help prevent dirt from scratching the window, always scrape in a forward di-

rection - pushing the scraper away from you - never back and forth.

## Steel wheels

Applies to vehicles: with steel wheels

*The wheels also have to be cleaned.*

- ▶ Always include the hub caps and wheel rims when washing your vehicle to remove road dirt, salt sprays and brake dust.

If necessary, use a commercial wheel cleaner to remove accumulated brake dust.

The wheel rims are easier to keep clean if they are regularly coated with liquid wax.

Paint scratches should be touched up as soon as possible to prevent corrosion ⇒ *page 168, Touch-up paint*.

### WARNING

- Moisture and ice on brakes may affect braking efficiency - ⇒ *page 153, General information*. Test the brakes carefully after each vehicle wash.
- Always read and heed all WARNINGS and the information ⇒ *page 164*.

## Cast (light) alloy wheels

Applies to vehicles: with Cast alloy wheels

*Cast (light) alloy wheels require special care.*

- ▶ Wash the wheels with a sponge or hose brush every other week.
- ▶ For deep cleaning afterwards, use only a dedicated **acid-free** cast alloy wheel cleaner.
- ▶ Rub a coat of **liquid wax** onto the rims every three months. Be sure to reach and treat all parts of the rim.

To preserve the decorative appearance of the cast alloy wheels, some special care is necessary. In addition to road dirt and salt, brake dust is also corrosive. If left on for too long, brake dust can cause pitting.

Use only special *acid-free* cleaners formulated for alloy rims. Safe products are available at your Audi dealer. Never leave the cleaner on

the rims longer than specified on the label. If not rinsed off promptly, the acid contained in some cleaners can attack the threads on the wheel bolts.

Never use abrasive or metal polishing cleaning agents. If the protective coating has been chipped, e.g. by kicked up road dirt, touch it up as soon as possible.

### **WARNING**

- Moisture and ice on brakes may affect braking efficiency ⇒ *page 153, General information*. Test the brakes carefully each time you wash the vehicle.
- Always read and heed all WARNINGS and other information ⇒ *page 164*.

### **Body cavity sealing**

*The body cavity sealing does not need to be checked.*

All body cavities which could be affected by corrosion have been given thorough protection at the factory.

This sealing does not require any inspection or additional treatment. If any wax should seep out of the cavity when the ambient temperature is high, it can be removed with a plastic scraper and a suitable solvent.

### **WARNING**

- Solvents can be dangerous.
- Benzine is flammable and toxic. If you use benzine for removing the wax, keep sparks, flame and lighted cigarettes away. Never dump benzine on the ground, into open streams or down sewage drains.
  - Be sure to observe all safety and environmental regulations. Follow all instructions on the container.
  - Always read and heed all WARNINGS and the information ⇒ *page 164*.

### **Chassis**

*Have the undercoating checked for damage from time to time.*

The lower body shell of your Audi is also thoroughly protected against corrosion.

Any damage to the undercoating caused by road hazards should be repaired promptly.

### **WARNING**

- Too much undercoating in the wrong places can cause a fire.
- Do not apply additional undercoating or rustproofing on or near the exhaust manifold, exhaust pipes, catalytic converter or heat shields. While driving, the substance used for undercoating could overheat and cause a fire.
  - Always read and heed all WARNINGS and other information ⇒ *page 164*.

### **Exhaust tail pipes**

Road salt and other corrosive materials will damage the material in the exhaust tail pipes if they are not cleaned regularly. Do not clean the tail pipes with wheel cleaner, paint polish, chrome polish or other abrasive cleaners. Clean the tail pipes with car care products that are suitable for stainless steel.

Your authorized Audi dealer can provide cleaning products that have been tested and approved for your vehicle.

## **Care of interior**

### **Radio-/Navigation\* display**

- ▶ Clean the display with a soft clean cloth and an LCD cleaner.

The display can be cleaned with a professionally available “LCD cleaner”. The cloth should be slightly dampened with the cleaning fluid to clean the display. ▶

**Note**

To avoid scratching the display, you should never clean it dry.

**Aluminum trim**

Use only **neutral-pH** products to remove spots and deposits from aluminum surfaces. Chrome care products and alkaline cleaners will attack aluminum surfaces and can damage them over time.

**WARNING**

Always read and heed all WARNINGS and the information ⇒ *page 164*.

**Fabrics and fabric coverings**

Fabrics and fabric coverings (e.g. seats, door trim panels, etc.) should be cleaned at regular intervals with a vacuum cleaner. This removes surface dirt particles which could become embedded in the fabric through use. Steam cleaners should not be used, because the steam tends to push the dirt deeper into the fabric and lock it there.

**Normal cleaning**

Generally, we recommend using a soft sponge or a lint-free microfiber cloth to clean fabric. Brushes should only be used for carpets and floor mats, since other fabric surfaces could be harmed by brushes.

Normal surface stains can be cleaned using a commercially available foam cleaner. Spread the foam on the surface of the fabric with a soft sponge and work it in gently. Do not saturate the fabric. Then pat the foam dry using absorbent, dry cloths (e.g. microfiber cloth) and vacuum it after it has dried completely.

**Cleaning stains**

Stains caused by beverages (e.g. coffee, fruit juice, etc.) can be treated with a mild detergent solution. Apply the detergent solution with a sponge. In the case of stubborn stains, a detergent paste can be applied directly to

the stain and worked into the fabric. Afterwards, use copious amounts of clean water to remove the remaining detergent. Apply the water with a damp cloth or sponge and pat the fabric dry with an absorbent, dry cloth.

Stains from chocolate or makeup should have detergent paste (e.g. ox-gall soap) rubbed into them. Afterwards, remove the soap with water (damp sponge).

Alcohol can be used to treat stains from grease, oil, lipstick or a ballpoint pen. Melted grease or dye must be patted off using absorbent material. It may be necessary to re-treat the areas with detergent paste and water.

In the case of general soiling of the upholstery and cover material, we recommend hiring a specialist that has the equipment to clean the seat covers and other fabric surfaces by shampooing and spray extraction.

**WARNING**

Always read and heed all WARNINGS and the information ⇒ *page 164*.

**Tips**

Open Velcro fasteners on your clothing can damage the seat cover. Please make sure that Velcro fasteners are closed.

**Plastic parts and instrument panel**

Always use a clean cloth moistened in clear water to clean these areas. For persistent dirt use an Audi approved **solvent-free** plastic cleaner/protectant.

**WARNING**

Solvents can change the properties of some plastics and make it harder for the airbag to deploy.

- Never clean the instrument panel or the surface of Airbag modules with cleaning products that contain solvents.
- Products containing solvents will make the surface of this part porous.

- Serious injuries can result if plastic parts come loose when the airbag is deployed.
- Always read and heed all WARNINGS and the information ⇨ *page 164*.

### **Note**

Cleaning agents containing solvents will attack the material and can change the way it behaves.

### **Instrument cluster glass**

- ▶ Clean the glass with a soft, damp cloth.

In order to preserve the anti-glare properties of the instrument cluster glass, it should only be cleaned with a soft, damp cloth.

### **Natural leather**

Applies to vehicles: with natural leather

*Audi makes great efforts to maintain the properties, natural look and feel of interior leather.*

#### **General**

We offer many different types of leather on our vehicles. Most are different types of nappa leather, which has a smooth surface and comes in various colors.

The intensity of the color determines the visual characteristics and appearance. If the surface of the leather has a typical natural look, then the leather is a nappa leather that has been left in a relatively natural condition. This leather offers particularly good comfort and breathes well. Fine veins, closed grains, insect bites, skin folds, and subtle variations in color remain visible. These characteristics demonstrate that the material is natural.

Natural nappa leather is not covered by a color finish. It is therefore more sensitive to soiling and wear, which is something you need to consider if children, animals or other factors might prove to be particularly hard on the leather.

By contrast, leather types that are covered by a colored finish layer are more durable. This

has a positive effect on the leather's resistance to wear and soiling in daily use. On the other hand, the typical characteristics of natural leather are barely or not apparent. However, this does not mean that the leather itself is of inferior quality.

#### **Care and handling**

Because of the exclusive nature of the types of leather that Audi uses and their unique properties (such as sensitivity to oils, grease, soiling, etc.), you will need to be somewhat careful with these leathers, and a certain type of care is required. For example, dark clothing materials can discolor leather seats (especially if such clothing is damp and was not dyed correctly). Dust and dirt particles in pores, folds, and seams can have an abrasive effect and can damage the leather surface as well as weaken seams.

The leather should be cleaned regularly as needed. After having been used for a relatively long time, your leather seats will acquire a rich aged finish. This is a characteristic of natural leather and a sign of true quality.

In order to maintain the value of this natural product over the life of your vehicle, you should follow the recommendations below:

### **Note**

- To keep your leather from bleaching out, do not allow it to be exposed to bright sunlight for long periods of time. If you have to leave the vehicle parked outside for long periods, cover the leather to protect it from direct exposure to sunlight.
- Sharp objects on clothing, such as zippers, rivets or sharp pieces on belts can leave permanent scratches or scrape marks on the surface of the leather.

### **Tips**

- After each time you clean the leather and at regular intervals, use a leather preservative creme that contains UV-blockers and that works into the leather. This

creme will nourish and moisturize the leather, helping it to breathe and stay supple. It also helps to build up a protective coating on the surface.

- Clean the leather every 2 - 3 months, and clean any areas that get soiled.
- Remove fresh marks made by ballpoint pens, ink, lipstick, shoe polish, etc. as soon as possible.
- Preserve the color of the leather as needed by using a special colored leather care creme to touch up areas of uneven color.

### Cleaning and caring for leather upholstery and trim

Applies to vehicles: with natural leather

*Natural leather requires special care and attention.*

#### Normal cleaning

- ▶ Clean soiled areas with a slightly moistened cotton or woolen cloth.

#### More stubborn dirt

- ▶ More stubborn dirt can be removed using a cloth saturated with a mild soap solution (2 tablespoons mild liquid soap).
- ▶ Never allow the soap solution to saturate the leather, and make certain that no water soaks into the seams.
- ▶ Wipe off the soap solution with a soft, dry cloth.

#### Cleaning spots

- ▶ Remove fresh **water-based** spots (such as coffee, tea, juices, blood) with an absorbent cloth or paper towel.
- ▶ Remove fresh **grease or oil-based spots** (such as butter, mayonnaise, chocolate) with an absorbent cloth or paper towel, or use the cleaner from the leather care kit if the spot has not yet penetrated into the surface of the leather.
- ▶ Use an oil/grease dissolving spray, if **oil/grease spots have dried on**.
- ▶ Remove specific kinds of spots (ballpoint pen, felt marker, fingernail polish, water-

based paint, shoe polish, etc.) with a spot remover specifically formulated for leather.

#### Leather care

- ▶ Every half year use an approved leather care product (available from your Audi dealer) to care for the leather.
- ▶ Apply the product very sparingly.
- ▶ Wipe it off with a damp cloth.

If you have any questions about cleaning and caring for the leather in your vehicle, it is best to contact your authorized Audi dealer, who will be glad to help you and tell you about our full range of leather care products, such as:

- Leather cleaning and care kit
- Cremes to care for colored leather
- Spot removers for ballpoint pens, shoe polish, etc.
- Oil/grease dissolving spray
- New and upcoming products.

#### WARNING

Always read and heed all WARNINGS and the information ⇒ *page 164*.

#### Note

- Never use chemical solvents (e.g. lighter fluid, turpentine), waxes, shoe polish or similar products on the leather surfaces in your Audi.
- To avoid damage, have stubborn stains removed by a commercial cleaning specialist.

### Cleaning Alcantara® (synthetic suede)

Applies to vehicles: with Alcantara upholstery

#### Removing dust and dirt

- ▶ Moisten a cloth, *squeeze out excess water* and wipe down the seat surfaces.

#### Removing stains

- ▶ Moisten a cloth with lukewarm water or with diluted **ethyl (rubbing) alcohol**.
- ▶ Dab at the stain. Start at the outside and work inwards.

- ▶ Once the stain is no longer visible, use a soft dry cloth or tissue to soak up the moisture.

Do not use leather cleaning products on Alcantara.

You may use a suitable shampoo for removing dust and dirt.

Dust and grit in the pores and seams can scratch and damage the surface. If the car is left standing in the sun for long periods, the Alcantara should be protected against direct sunlight to prevent it from fading. Slight color variations will develop in normal use and are not an indication of material deterioration.

### **Note**

- Never use chemical solvents (e.g. lighter fluid, turpentine), waxes, shoe polish or similar products on Alcantara® surfaces.
- To avoid damage, have stubborn stains removed by a commercial cleaning specialist.
- Do not use brushes, stiff sponges or similarly abrasive cleaning aids.

### **Safety belts**

*Only well-maintained safety belts work reliably when needed.*

Heavily soiled safety belts may not retract properly.

- ▶ Keep belts clean.
- ▶ For cleaning, use a mild soap and water solution. Let belts dry thoroughly and away from direct sunlight.
- ▶ Do not allow inertia reel safety belts to retract before they are completely dry.
- ▶ Check the condition of your safety belts *regularly*.

### **WARNING**

Damaged safety belts can break in a crash.

- Anything that might damage your safety belts could mean that you and your passengers would not be adequately protected in an accident.
- Safety belt performance depends on correct installation. Never remove belts from the vehicle to clean them.
- Do not use chemical cleaning agents, bleach or dyes. They have corrosive properties which weaken the webbing.
- When cleaning your safety belts, inspect them for damage. If you discover damage, see your Audi dealer.
- Always read and heed all WARNINGS and the information ⇨ *page 164*.

### **Engine compartment**

*Be especially careful when cleaning the engine compartment.*

**Always switch off the ignition before cleaning the engine** ⇨ .

#### **Plenum panel**

Remove leaves from the plenum panel in front of the windshield under the engine hood. This prevents the water drain holes from becoming blocked, and it prevents debris from entering the vehicle interior through the heating and ventilation ducts.

#### **Corrosion protection**

The engine compartment and transmission have been corrosion-protected at the factory.

Good anti-corrosion treatment is very important, particularly in the winter. If the vehicle is frequently driven on salt treated roads, the entire engine compartment and plenum panel should be thoroughly cleaned at the end of winter and retreated to prevent salt damage. At the same time, the underside of the vehicle should be washed as well.

If the engine compartment is cleaned at any time with grease removing solutions<sup>1)</sup>, or if

<sup>1)</sup> Use only the correct cleaning solutions. Never use gasoline or diesel fuel.

you have the engine washed, the anti-corrosion treatment is almost always removed as well. It is therefore essential to have a long-lasting corrosion protection reapplied to all surfaces, seams, joints and components in the engine compartment.

 **WARNING**

Be aware: The engine compartment of any motor vehicle is a potentially hazardous area.

- Before working in the engine compartment, be sure to read the information ⇒ *page 174*.
- Before reaching into the front plenum panel, always remove the ignition key. Otherwise, the windshield wiper system could unintentionally be switched on, possibly causing personal injury from the moving wiper linkage.
- Never reach into the area around or touch the radiator fan. The auxiliary fan is temperature controlled and can switch on suddenly - even when the ignition is off.
- Do not wash, wax or dry the engine with the engine running. Moving or hot parts could injure you.
- Do not clean the underside of the chassis, fenders, wheel covers, or other hard to reach parts without protecting your hands and arms. You may cut yourself on sharp-edged metal parts.
- Always read and heed all WARNINGS and other information ⇒ *page 164*.

## Fuel supply and filling your fuel tank

### Gasoline

#### Fuel supply

*Using the right fuel helps keep the environment clean and prevents engine damage.*

#### Fuel recommendation

The fuel recommended for your vehicle is **unleaded premium** grade gasoline. See also ⇒ *page 240, Data*. Audi recommends using TOP TIER Detergent Gasoline with a minimum octane rating of 91 AKI (95 RON). For more information on TOP TIER Detergent Gasoline, please go to the official website ([www.toptier-gas.com](http://www.toptier-gas.com)).

The recommended gasoline octane rating for your engine can also be found on a label located on the inside of the fuel filler flap. This rating may be specified as AKI or RON.

Your vehicle may also be operated using unleaded regular gasoline with a minimum octane rating of 87 AKI/91 RON. However, using 87 AKI/91 RON octane fuel will slightly reduce engine performance.

**Use unleaded gasoline only.** Unleaded gasoline is available throughout the USA, Canada, and in most European countries. We recommend that you do not take your vehicle to areas or countries where unleaded gasoline may not be available.

For more information on refueling your vehicle, see ⇒ *page 177*.

#### Octane rating

Octane rating indicates a gasoline's ability to resist engine damaging "knock" caused by premature ignition and detonation. Therefore, buying the correct grade of gasoline is very important to help prevent possible engine damage and a loss of engine performance.

Gasoline most commonly used in the United States and Canada has the following octane

ratings that can usually be found on the filler pump:

- Premium Grade: 91 - 96 AKI
- Regular Grade: 87 - 90 AKI

Explanation of the abbreviations:

AKI = **A**nti **K**nock **I**ndex =  $(R+M)/2 = (RON + MON)/2$

RON = **R**esearch **O**ctane **N**umber

MON = **M**otor **O**ctane **N**umber.



#### Note

- Do not use any fuel with octane ratings lower than 87 AKI or 91 RON otherwise expensive engine damage will occur.
- Do **not** use leaded gasoline! The use of leaded gasoline will severely damage your vehicle's catalytic converter and its ability to control exhaust emissions.

#### Blended gasoline

##### Use of gasoline containing alcohol or MTBE (methyl tertiary butyl ether)

You may use unleaded gasoline blended with alcohol or MTBE (commonly referred to as oxygenates) if the blended mixture meets the following criteria:

##### Blend of gasoline methanol (wood alcohol or methyl alcohol)

- Anti-knock index must be 87 AKI or higher.
- Blend must contain no more than 3% methanol.
- Blend must contain more than 2% co-solvents.

##### Blend of gasoline and ethanol (grain alcohol or ethyl alcohol)

- Anti-knock index must be 87 AKI or higher.
- Blend must not contain more than 10% ethanol.

##### Blend of gasoline and MTBE

- Anti-knock index must be 87 AKI or higher. ►

- Blend must contain not more than 15% MTBE.

### Seasonally adjusted gasoline

Many gasoline grades are blended to perform especially well for winter or summer driving. During seasonal change-over, we suggest that you fill up at busy gas stations where the seasonal adjustment is more likely to be made in time.

#### Note

- Methanol fuels which do not meet these requirements may cause corrosion and damage to plastic and rubber components in the fuel system.
- Do not use fuels that fail to meet the specified criteria in this chapter.
- If you are unable to determine whether or not a particular fuel blend meets the specifications, ask your service station or its fuel supplier.
- Do not use fuel for which the contents cannot be identified.
- Fuel system damage and performance problems resulting from the use of fuels different from those specified are not the responsibility of Audi and are not covered under the New Vehicle or the Emission Control System Warranties.
- If you experience a loss of fuel economy or driveability and performance problems due to the use of one of these fuel blends, we recommend that you switch to unblended fuel.

### Gasoline additives

A major concern among many auto manufacturers is carbon deposit build-up caused by the type of gasoline you use.

Although gasoline grades differ from one manufacturer to another, they have certain things in common. All gasoline grades contain substances that can cause deposits to collect on vital engine parts, such as fuel injectors and intake valves. Although most gasoline brands include additives to keep engine and

fuel systems clean, they are not equally effective.

Audi recommends using TOP TIER Detergent Gasoline. For more information on TOP TIER Detergent Gasoline, please go to the official website ([www.toptiergas.com](http://www.toptiergas.com)).

After an extended period of using inadequate fuels, built-up carbon deposits can rob your engine of peak performance.

#### Note

Damage or malfunction due to poor fuel quality is not covered by the Audi New Vehicle Limited Warranty.

## Fuel tank

### Fuel filler neck

The fuel filler neck is located on the right rear side panel behind the fuel filler flap.

If the unlocking system should fail, you can still open the flap manually - for detailed instructions see ⇒ *page 179*.

You can find the fuel tank capacity of your vehicle in **Technical Data** ⇒ *page 240*.

The label on the inside of the fuel filler flap tells you the correct fuel for your vehicle. For more information about fuel specifications, see ⇒ *page 176*.

Your vehicle fuel tank has an on-board refueling vapor recovery system. This feature helps to prevent fuel vapors from escaping from the tank and polluting the environment while you refuel your vehicle. In order to fill the tank properly while protecting the environment, please follow this refueling procedure carefully.

#### WARNING

Under normal operating conditions, never carry additional fuel containers in your car. Gas canisters and other containers used to transport fuel can be dangerous. Such containers, full or empty, may leak and could cause a fire in a collision. If you must

transport fuel to use for your lawn mower, snow blower, etc., be very careful and always observe local and state laws regarding the use, transportation and storage of such fuel containers. Make certain the container meets industry standards (ANSI/ASTM F852 - 86).

### ! Note

Never drive your vehicle until the fuel tank is completely dry. The irregular supply of fuel can cause misfiring. Gasoline could enter into the exhaust system and damage the catalytic converter.

## Refuelling



Fig. 129 Driver's door: Unlocking fuel filler flap



Fig. 130 Fuel cap hooked on the opened fuel filler flap

When adding fuel, the ignition and any cellular phones in the vehicle must be switched off.

### Taking the fuel cap off

- ▶ To open the fuel filler flap, pull the button ⇒ *fig. 129*.
- ▶ Unscrew fuel filler cap counter-clockwise and hang it on the fuel filler flap ⇒ *fig. 130*.

### Refuelling procedure

- ▶ Insert the fuel nozzle from the gasoline pump into the fuel filler neck as far as it will go.
- ▶ Select a medium refuelling rate so that the nozzle switches off automatically when the tank is full.

### Putting the fuel cap back on

- ▶ After filling your tank, twist the fuel filler cap clockwise until you hear a definite click.
- ▶ Close the fuel filler flap.

To avoid fuel spilling or evaporating from the fuel tank always close fuel filler cap properly and completely. An improperly closed fuel filler cap may also cause the MIL lamp ⇒ *page 30* to come on.

### ! WARNING

Improper refueling or handling of fuel can cause fire, explosion and severe burns.

- Fuel is highly flammable and can cause severe burns and other injuries.
- Failure to shut the engine off while refueling and/or to insert the pump nozzle fully into the fuel filler neck could cause fuel to spray out of filler neck or to overflow. Fuel spray and overflowing fuel can cause a fire.
- Never use a cellular telephone while refueling. The electromagnetic radiation can cause sparks that can ignite fuel vapors and cause a fire.
- Never get back into your vehicle while refueling. If in exceptional circumstances you must get back in your vehicle while refueling, make certain that you close the door and touch metal to discharge static electricity before touching the filler nozzle again. Static electricity can cause sparks that can ignite fuel vapors released during refueling.
- Never smoke or have an open flame anywhere in or near your vehicle when refueling or filling a portable fuel container.

- For your safety, we strongly recommend that you do not travel with a portable fuel container in your vehicle. The container, full or empty may leak and could cause a fire, especially in a crash.
- If, under exceptional circumstances, you must transport a portable fuel container, please observe the following:
  - Never fill a portable fuel container while it is anywhere in or on the vehicle (for example, in the luggage compartment, or on the trunk). Static electricity can build up while filling and can ignite fuel vapors causing a fire.
  - Always place a portable fuel container on the ground before filling.
  - Always keep the filler nozzle completely inside the portable container before and during filling.
  - If filling a portable container made of metal, the filler nozzle must always be in contact with the container. This will help prevent static electricity from discharging and cause a fire.
  - Never spill fuel inside the vehicle or luggage compartment. Fuel vapors are highly flammable.
  - Always observe local and state/provincial laws regarding the use, storage and transportation of fuel containers.
  - Make certain the fuel container meets industry standards (ANSI / ASTM F852-86).

### Note

If any fuel has spilled onto the car, it should be removed immediately to prevent damage to the paint.

### For the sake of the environment

As soon as the correctly operated nozzle switches off automatically for the first time, the tank is full. Do not try to add more fuel because fuel may spill out. In addition, the expansion space in the fuel tank will be filled - causing the fuel to

overflow when it becomes warm and pollute the environment.

### Tips

- Running your engine while refuelling may cause vapors to escape or even fuel to spill out of the tank. This would then shut off the fuel nozzle before the tank is full.
- Do not refuel your vehicle with the ignition switched on. The fuel gauge may otherwise not indicate the correct fuel level after refuelling.

### Unlocking the fuel filler flap by hand

You can open the fuel filler flap by hand if the power locking system should fail.

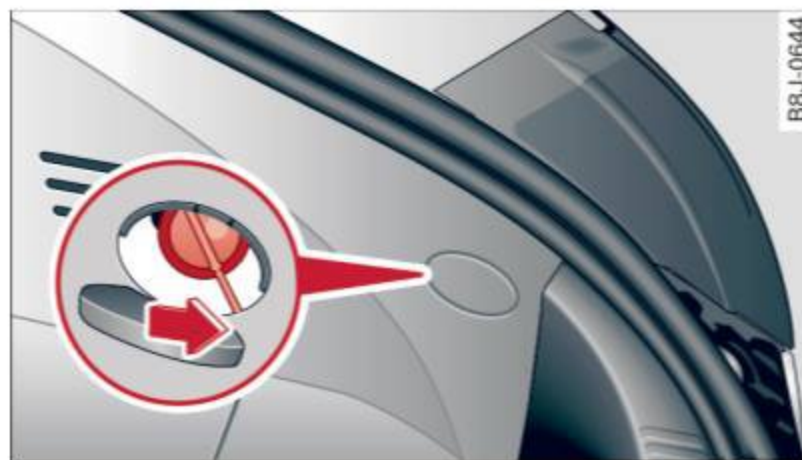

**Fig. 131** Luggage compartment: Cover in the right-side interior trim

If the power locking system should fail, you can still open the flap manually:

- ▶ Open the rear lid.
- ▶ Open the round cover in the right-side interior trim.
- ▶ Remove the red plastic knob from its retainer.
- ▶ Pull the plastic cord in the direction of the arrow to unlock the fuel filler flap  
⇒ *fig. 131*.

## Checking and filling

### Engine hood

#### Releasing the engine hood

The engine hood is released from inside the vehicle.

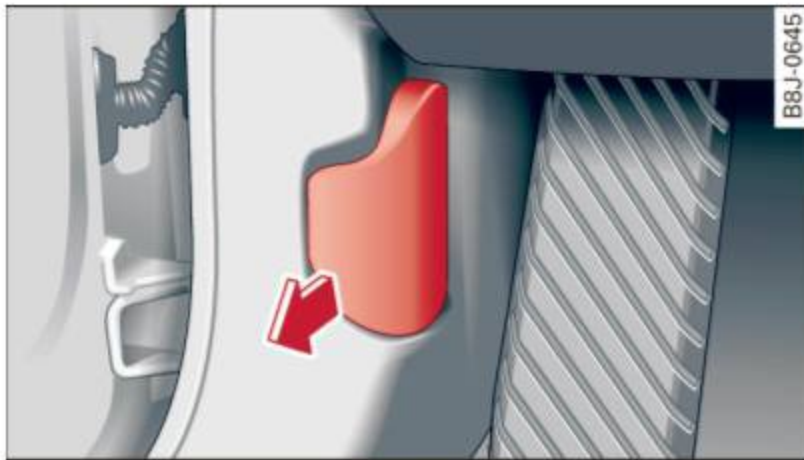

Fig. 132 Driver's side footwell: engine hood release lever

- ▶ Open the driver's door.
- ▶ Pull the release lever on the left under the instrument panel ⇒ *fig. 132* in the direction of the arrow.

The hood pops up slightly under spring pressure.

#### Opening the engine hood



Fig. 133 Release lever under the engine hood

Before opening the engine hood, make sure that the windshield wipers are flat against the windshield. Otherwise, they could damage the paint on the hood.

- ▶ Lift the hood slightly ⇒ ⚠.
- ▶ Pull up on the release under the hood ⇒ *fig. 133*. This releases the catch.
- ▶ Open the hood all the way.

#### ⚠ WARNING

Hot engine coolant can burn you.

- To reduce the risk of being burned, never open the hood if you see or hear steam or coolant escaping from the engine compartment. Wait until no steam or coolant can be seen or heard before carefully opening the hood.

#### Closing the engine hood

- ▶ Pull the hood down until the pressure from the struts is reduced.
- ▶ Let the hood *drop down* and latch in place. Do not try to push it shut; it may fail to engage ⇒ ⚠.

#### ⚠ WARNING

A hood that is not completely latched could fly up and block your view while driving.

- When you close the engine hood, check it to make sure the safety catch has properly engaged. The hood should be flush with the surrounding vehicle body parts.
- If you notice while driving that the hood is not secured properly, stop at once and close it.

#### Working in the engine compartment

Be especially careful whenever you work in the engine compartment!

Whenever you must perform any work in the engine compartment, for example checking and filling the different fluids, there is a risk of injury, burns and accidents. To prevent personal injury always observe the following **WARNINGS**. The engine compartment of any vehicle is a hazardous area! ⇒ ⚠

#### ⚠ WARNING

To help avoid injury, before you check anything under the hood:

- Switch off the engine.
- Remove the ignition key.

- Apply the parking brake.
- Move selector lever of automatic transmission to “P” (Park); put manual transmission in Neutral.
- Always let the engine cool down. Hot components will burn skin on contact.
- To reduce the risk of being burned, never open the hood if you see or hear steam or coolant escaping from the engine compartment. Wait until no steam or coolant can be seen or heard before carefully opening the hood.
- Keep children away from the engine compartment.
- Never spill fluids on hot engine components. They can cause a fire.
- Never touch the radiator fan. The auxiliary electric fan is temperature controlled and can switch on suddenly.
- Never open the coolant reservoir cap when the engine is still warm. The coolant system is pressurized and hot coolant could spray out.
- Protect your face, hands and arm from steam or hot engine coolant by placing a thick rag over the cap when you open the coolant reservoir.
- Do not remove the engine cover under any circumstances. This increases the risk of burns.
- If work on the fuel system or the electrical system is necessary:
  - Always disconnect the battery.
  - Never smoke or work near heaters or open flames. Fluids in the engine compartment could start a fire.
  - Keep an approved fire extinguisher immediately available.
- To avoid electrical shock and personal injury while the engine is running or being started, never touch:
  - Ignition cables
  - Other components of the high voltage electronic ignition system.
- If you must perform a check or repair with the engine running:

- First, fully apply the parking brake, move selector lever of automatic transmission to “P” (Park); put manual transmission in Neutral.
- Always use extreme caution to prevent clothing, jewelry, or long hair from getting caught in the radiator fan, V-belts or other moving parts, or from contacting hot parts. Tie back hair before starting, and wear no clothing that will hang or droop into the engine.
- Minimize exposure to emission and chemical hazards ⇒ ⚠.

### WARNING

California Proposition 65 Warning:

- Engine exhaust, some of its constituents, and certain vehicle components contain or emit chemicals known to the State of California to cause cancer and birth defects and reproductive harm. In addition, certain fluids contained in vehicles and certain products of component wear contain or emit chemicals known to the State of California to cause cancer and birth defects or other reproductive harm.
- Battery posts, terminals and related accessories contain lead and lead compounds, chemicals known to the State of California to cause cancer and reproductive harms. Wash hands after handling.

### Note

When adding fluids, always make sure that they are poured into the proper container or filler opening, otherwise serious damage to vehicle systems will occur.

### For the sake of the environment

To detect leaks in time, inspect the vehicle floor pan from underneath regularly. If you see spots from oil or other vehicle fluids, have your vehicle inspected by an authorized Audi dealer.

## Engine compartment

These are the most important items that you can check.

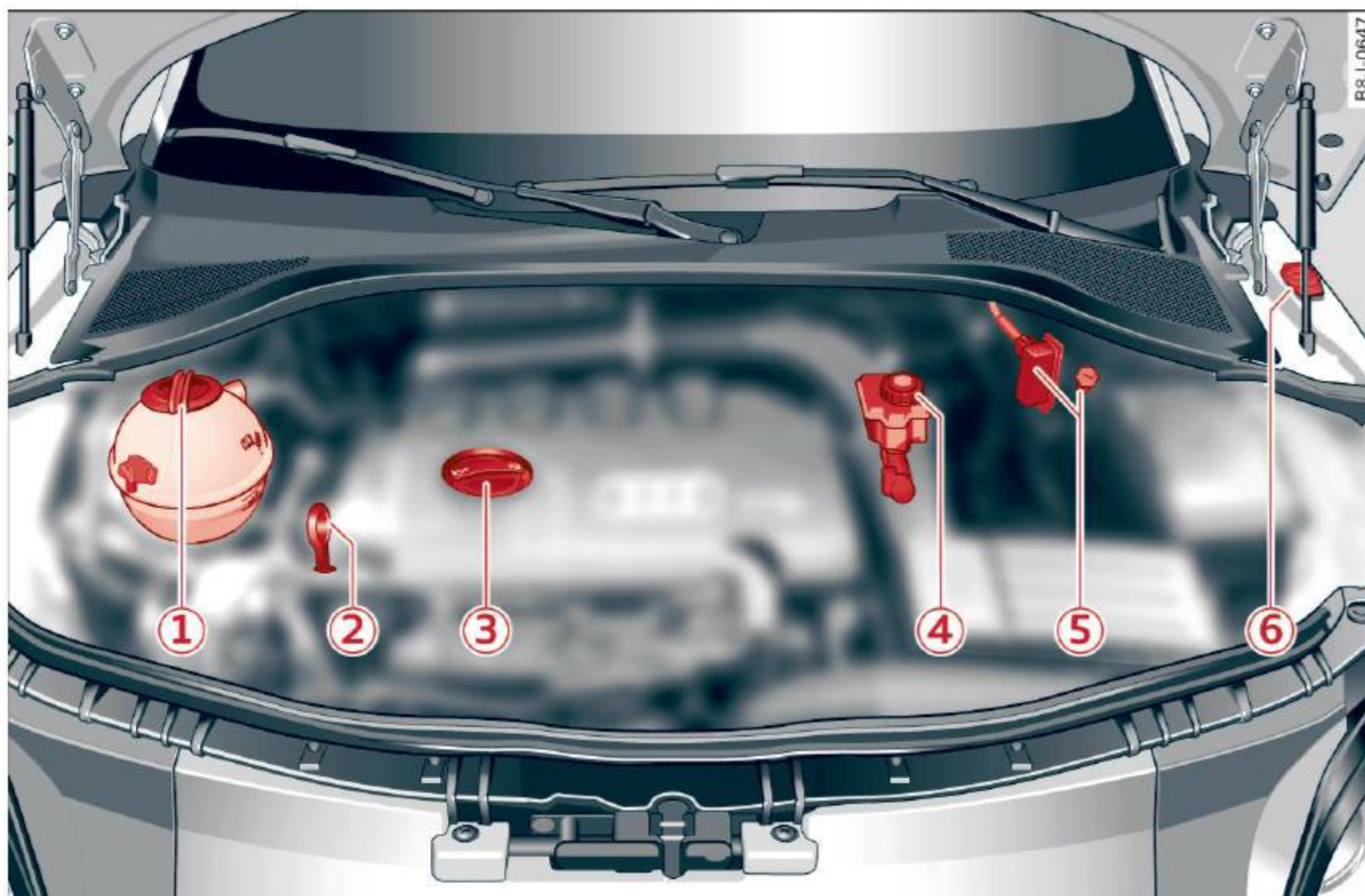

Fig. 134 Typical layout for containers and engine oil filler cap

- |   |  |     |
|---|--|-----|
| ① | Coolant expansion tank (☞) . . .                             | 187 |
| ② | Engine oil dipstick . . . . .                                | 185 |
| ③ | Engine oil filler cap (☞) . . . . .                          | 185 |
| ④ | Brake fluid reservoir (☞) . . . . .                          | 189 |
| ⑤ | Jump start points (+) under a cover, (-) bolt head . . . . . | 233 |
| ⑥ | Windshield/headlight washer container (☞) . . . . .          | 194 |

The position of the engine oil dipstick and the engine oil filling hole ⇒ *fig. 134* (items ② and ③) can differ depending on the engine design.

### ⚠ WARNING

Before you check anything in the engine compartment, always read and heed all WARNINGS ⇒ ⚠ in *Working in the engine compartment* on page 180.

## Engine oil

### Engine oil specifications

*The engine oil used in your Audi needs the right kind of oil.*

The engine in your Audi is a sophisticated powerplant that was built to exacting specifications. This engine needs the right kind of engine oil that meets specifications regarding quality and viscosity so that it can run smoothly and reliably. Choosing the right oil and changing oil within the time and mileage intervals printed in your vehicle's Warranty & Maintenance booklet matters a lot more today than it did years ago. Audi has developed a special quality standard for engine oil that will help assure that your vehicle's engine will get the lubrication it needs for proper operation.

Modern engine lubrication has taken a quantum leap in the last few years. Many synthetic ►

oils available today provide better engine lubrication that can outlast traditional petroleum-based oils, making them a smart choice for use throughout the life of your Audi.

Whether you use synthetic or petroleum-based engine oil, the oil that you use must conform to Audi's oil quality standard VW 502 00 to help keep your vehicle's engine running smoothly and help prevent the formation of harmful deposits, sometimes called "sludge," that over time can lead to expensive repairs.

At the time of printing, engine oils available in the U.S. and Canada that meet the exacting specifications of Audi oil standard VW 502 00 are synthetic engine oils. This does not mean, however, that every synthetic engine oil will meet Audi oil standard VW 502 00. So always be sure that you use an approved oil.

To help prevent the formation of harmful deposits use only oil with the following specifications printed on the oil container:

#### **Audi oil standard VW 502 00**

Oil container labels may carry the specification singly or in combination with other designations and oil quality standards.

#### **Viscosity**

Engine oils are graded according to their viscosity. The proper viscosity grade oil for your engine depends on climactic or seasonal conditions where you drive. You can use oil with a viscosity grade of SAE 5W40 across all temperature ranges for normal driving conditions.

However, if engine oil viscosity grade SAE 5W40 is not available, you can also use viscosity grade SAE 5W-30 or SAE 0W-40 as long as it meets Audi oil quality standard VW 502 00 specifications.

Because engine oil that meets the Audi oil standard may not be available everywhere when you need it, we strongly recommend that you always carry with you an extra quart (liter) of oil that expressly conforms to the

VW 502 00 specification, in case you have to top off the oil while on the road.

Only if the level of the oil is at or below the minimum mark on the oil dipstick - and no oil that expressly conforms to Audi oil standard VW 502 00 specifications is available - may you top off with a high quality engine oil, preferably synthetic-based, that meets ACEA A3 or API SM specifications, but even then, only in viscosity grades SAE 5W-40, SAE 5W-30, or SAE 0W-40. However, during the entire time between oil change intervals, never top off with more than a total of 0.5 qt/liter engine oil that does not conform to Audi oil specification VW 502 00.

For more information about engine oil that has been approved for your vehicle, please contact either your authorized Audi dealer or Audi Customer Relations at 1 (800) 822-2834 or visit our web site at [www.audiusa.com](http://www.audiusa.com) or [www.audicanada.ca](http://www.audicanada.ca). Here you will also find a current list of oils (manufacturers, brand names etc.) that conform to Audi oil standard VW 502 00.

#### **Changing the engine oil**

The engine oil and oil filter must be changed according to the mileage (kilometers) and time intervals specified in your vehicle's Warranty & Maintenance booklet. Do not exceed these intervals - harmful deposits from old engine oil can reduce engine performance and can lead to expensive engine repairs.

Changing the oil at the recommended intervals is so very important because the lubricating properties of oil decrease gradually during normal vehicle use. If you are not sure when you have your oil changed, ask your authorized Audi Service Advisor.

Under some circumstances the engine oil should even be changed more frequently. Change oil more often if you drive mostly short distances, operate the vehicle in dusty areas or mostly under stop-and-go traffic conditions, or when you use your vehicle where temperatures stay below freezing point for long periods. ▶

Detergent additives in the oil will make fresh oil look dark after the engine has been running for a short time. This is normal and is not a reason to change the oil more often than recommended.

### **Damage or malfunctions due to lack of maintenance**

It is essential that you change your oil at the recommended intervals using only engine oil that complies with Audi oil standard VW 502 00. Your Limited New Vehicle Warranty does not cover damage or malfunctions due to failure to follow recommended maintenance and use requirements as set forth in the Audi Owner's Manual and Warranty & Maintenance booklet. Your dealer will have to deny warranty coverage unless you present to the dealer proof in the form of Service or Repair Orders that all scheduled maintenance was performed in a timely manner.

### **Engine oil consumption**

*The engine in your vehicle depends on an adequate amount of oil to lubricate and cool all of its moving parts.*

In order to provide effective lubrication and cooling of internal engine components, all internal combustion engines consume a certain amount of oil. Oil consumption varies from engine to engine and may change significantly over the life of the engine. Typically, engines with a specified break-in period (see ⇒ *page 159*) consume more oil during the break-in period than they consume after oil consumption has stabilized.

Under normal conditions, the rate of oil consumption depends on the quality and viscosity of the oil, the RPM (revolutions per minute) at which the engine is operated, the ambient temperature and road conditions. Further factors are the amount of oil dilution from water condensation or fuel residue and the oxidation level of the oil. As any engine is subject to wear as mileage builds up, the oil consumption may increase over time until replacement of worn components may become necessary.

With all these variables coming into play, no standard rate of oil consumption can be established or specified. There is no alternative to regular and frequent checking of the oil level, see **Note**.

If the yellow engine oil level warning symbol in the instrument cluster  lights up, you should check the oil level as soon as possible *with the oil dipstick* ⇒ *page 185*. Top off the oil at your earliest convenience ⇒ *page 185*.

### **WARNING**

Before you check anything in the engine compartment, always read and heed all WARNINGS ⇒  *in Working in the engine compartment on page 180*.

### **Note**

Driving with an insufficient oil level is likely to cause severe damage to the engine.

### **Tips**

- The oil pressure warning display  is not an indicator of the oil level. Do not rely on it. Instead, check the oil level in your engine at regular intervals, preferably each time you refuel, and always before going on a long trip.
- If you have the impression your engine consumes excessive amounts of oil, we recommend that you consult your Audi dealer to have the cause of your concern properly diagnosed. Keep in mind that the accurate measurement of oil consumption requires great care and may take some time. Your Audi dealer has instructions about how to measure oil consumption accurately.

**Checking the engine oil level**

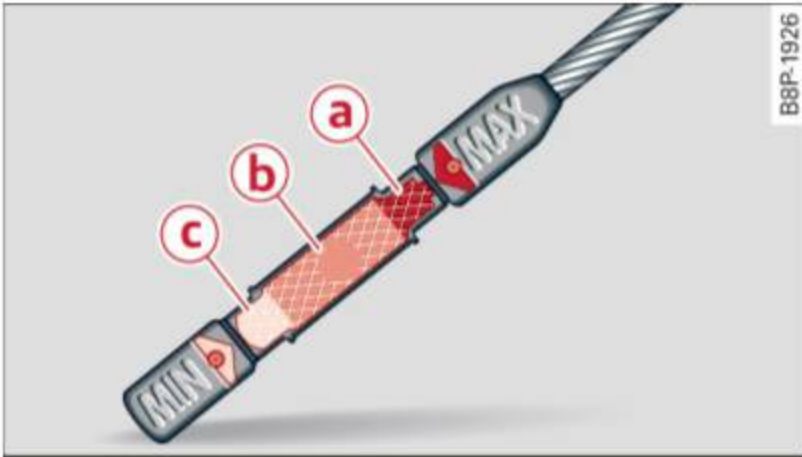

**Fig. 135** Illustration of principle 1: Markers on oil dipstick

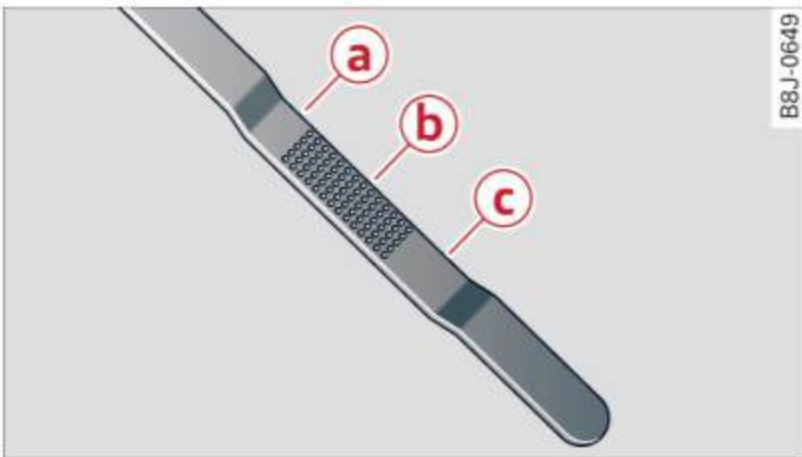

**Fig. 136** Illustration of principle 2: Markers on oil dipstick

Before you check anything in the engine compartment, **always read and heed all WARNINGS** ⇒ in *Working in the engine compartment on page 180*.

**Determining oil level**

- ▶ Park your vehicle on a level surface.
- ▶ While at operating state temperature, briefly let the engine run at idle and then shut it off.
- ▶ Wait approx. two minutes.
- ▶ Pull out the oil dipstick. Wipe off the oil dipstick with a clean cloth, and slide it back in as far as it will go.
- ▶ Pull it back out and read off the oil level ⇒ *fig. 135* or ⇒ *fig. 136*. Top off the engine oil, if applicable ⇒ *page 185*.

**Oil level within range (a)**

- ▶ Do not add oil.

**Oil level within range (b)**

- ▶ You can add oil. Afterwards, the oil level should be within range (a).

**Oil level within range (c)**

- ▶ You must add oil. Afterwards, the oil level should be within range (a).

The oil level needs to be checked at regular intervals. The best times to do this are whenever you refuel and prior to long trips.

Depending on the way the vehicle is driven and the operating conditions, oil consumption can be up to 1/2 quart per 600 miles (0.5 liter per 1,000 km). Consumption may be higher within the first 3,000 miles (5,000 km).

**Adding engine oil**



**Fig. 137** Engine compartment: cover on the engine oil filler neck

Before you check anything in the engine compartment, **always read and heed all WARNINGS** ⇒ in *Working in the engine compartment on page 180*.

- ▶ Unscrew the cap to the engine oil filling hole ⇒ *page 182, fig. 134*.
- ▶ Carefully top off with the appropriate oil in 0.5 liter doses.
- ▶ Check the oil level again after two minutes ⇒ *page 185*.
- ▶ Top off the oil again, if necessary.
- ▶ Screw the cap back on the filling hole and slide the oil dipstick in as far as it will go.

**WARNING**

- While topping off, the oil must not come in contact with hot engine parts - fire hazard!
- The oil filler cap must be properly secured to prevent oil from being sprayed

- on the hot engine and exhaust system when the engine is running - fire hazard!
- If your skin has come in contact with the engine oil, you must subsequently cleanse it thoroughly.

### Note

- The oil level must not be above range  - danger of converter or engine damage! Contact an authorized Audi dealer to draw off oil, if necessary.
- **Audi does not recommend the use of oil additives. They may damage the engine and adversely affect your New Vehicle Warranty.**

### For the sake of the environment

- Under no circumstances can the oil come in contact with the sewage network or the soil.
- Observe and follow legal regulations when disposing of empty oil containers.

## Changing the engine oil

*We recommend that have your oil changed by an authorized Audi dealer or a qualified service station.*

Before you check anything in the engine compartment, **always read and heed all WARNINGS** ⇨  in *Working in the engine compartment on page 180.*

The engine oil must be changed according to the intervals specified in your Warranty & Maintenance booklet. This is very important because the lubricating properties of oil diminish gradually during normal vehicle use.

Under some circumstances the engine oil should be changed more frequently. Change oil more often if you drive mostly short distances, operate the vehicle in dusty areas or under predominantly stop-and-go traffic conditions, or have your vehicle where temperatures remain below freezing for extended periods.

Detergent additives in the oil will make fresh oil look dark after the engine has been running for a short time. This is normal and is not a reason to change the oil more often than recommended.

Because of the problem of proper disposal, along with the special tools and necessary expertise required, we strongly recommend that you have your oil changed by an authorized **Audi dealer** or a qualified service station.

**If you choose to change your oil yourself,** please note the following important information:

### WARNING

- To reduce the risk of personal injury if you must change the engine oil in your vehicle yourself:
- Wear eye protection.
  - To reduce the risk of burns from hot engine oil, let the engine cool down to the touch.
  - When removing the oil drain plug with your fingers, stay as far away as possible. Always keep your forearm parallel to the ground to help prevent hot oil from running down your arm.
  - Drain the oil into a container designed for this purpose, one large enough to hold at least the total amount of oil in your engine.
  - Engine oil is poisonous. Keep it well out of the reach of children.
  - Continuous contact with used engine oil is harmful to your skin. Always protect your skin by washing oil off thoroughly with soap and water.

### Note

Never mix oil additives with your engine oil. These additives can damage your engine and adversely affect your Audi Limited New Vehicle Warranty. ▶



### For the sake of the environment

- Before changing your oil, first make sure you know where you can properly dispose of the used oil.
- Always dispose of used engine oil properly. Do not dump it on garden soil, wooded areas, into open streams or down sewage drains.
- Recycle used engine oil by taking it to a used engine oil collection facility in your area, or contact a service station.

## Engine cooling system

### Coolant

*The engine coolant performs two functions: it keeps the engine from overheating and it protects the engine from freezing in the winter.*

The cooling system is sealed and generally requires little attention.

The cooling system has been filled at the factory with a permanent coolant which does not need to be changed. The coolant consists of a mixture of water and the manufacturer's glycol-based coolant additive G13 antifreeze with anticorrosion additives (50% for USA models; 60% for Canadian models). This mixture both assures the necessary frost protection and protects metal components in the engine's cooling system from corrosion and scaling. It also raises the boiling point of the coolant.

Do not reduce the concentration of the coolant in the summer by adding plain water. **The proportion of coolant additive must be at least 50% but not more than 60%** to maintain antifreeze protection and cooling efficiency. If the coolant frost protection is too low, the coolant could freeze and damage the vehicle heating and engine cooling system.

For year-round driving, antifreeze is added at the factory for temperatures down to:

- - 31 °F ( - 35 °C) USA
- - 40 °F ( - 40 °C) Canada.



### WARNING

Before you check anything in the engine compartment, always read and heed all WARNINGS ⇒ in *Working in the engine compartment* on page 180.



### Note

- Before winter sets in, have the coolant checked to see if the coolant additive in your vehicle is sufficient to meet the climate conditions. This is especially important if you live in a region where the winter is extremely cold. If necessary, increase the proportion of coolant additive to 60%.
- When adding coolant additive to your cooling system, remember:
  - We recommend using only coolant additive G12++ or G13 (check the label) for your vehicle. This coolant additive is available at authorized Audi dealers. Other types of antifreeze can significantly reduce corrosion protection. The resulting corrosion can cause a loss of coolant and serious engine damage.
  - Do not add any type of radiator leak sealant to your vehicle's engine coolant. Adding radiator repair fluid may adversely affect the function and performance of your cooling system and could result in damage not covered by your New Vehicle Limited Warranty.

### Checking the engine coolant level

*The engine coolant level can be checked with a quick glance.*



**Fig. 138** Engine compartment: cover on the coolant expansion tank

Before you check anything in the engine compartment, **always read and heed all WARNINGS** ⇒  in *Working in the engine compartment* on page 180.

- ▶ Park your vehicle on a level surface.
- ▶ Switch the ignition off.
- ▶ Read the coolant level at the coolant expansion tank ⇒ page 182, fig. 134. With a cold engine, it must be above the “min” mark. With a hot engine, it can be a little above the indicated range.

The location of the coolant expansion tank can be seen in the engine compartment illustration ⇒ page 182.

To obtain an accurate reading, the engine must be switched off.

The expansion tank in your vehicle is equipped with an electric coolant level sensor.

When the coolant level is too low, the warning light in the Auto-Check System ⇒ page 16 will illuminate until you add coolant and the level has been restored to normal. Even though there is an electric coolant level sensor, we still recommend you check the coolant level from time to time.

### Coolant loss

Coolant loss may indicate a **leak** in the cooling system. In the event of coolant loss, the cooling system should be inspected immediately by your authorized Audi dealer. It is not enough merely to add coolant.

In a **sealed** system, losses can occur only if the boiling point of the coolant is exceeded as a result of overheating.

#### Note

Do not add any type of radiator leak sealant to your vehicle's engine coolant. Adding radiator repair fluid may adversely affect the function and performance of your cooling system and could result in damage not covered by your New Vehicle Limited Warranty.

### Adding coolant

*Be very careful when adding engine coolant.*

Before you check anything in the engine compartment, **always read and heed all WARNINGS** ⇒  in *Working in the engine compartment* on page 180.

- ▶ Turn off the engine.
- ▶ Let the engine cool down.
- ▶ Place a thick rag over the coolant expansion tank ⇒ page 187, fig. 138 and **carefully** twist the cap counter-clockwise ⇒ .
- ▶ Add coolant.
- ▶ Twist the cap on again *tightly*.

Replacement engine coolant must conform to exact specifications ⇒ page 187, *Coolant*.

Even in an emergency, if coolant additive G12++, G12+ or G12 is not available, do **not** use a different additive. Use plain water instead until you can get the correct additive and can restore the correct ratio. This should be done as soon as possible.

If you have lost a considerable amount of coolant, then you should add cold antifreeze and cold water only when the engine is cold.

Always use *new* engine coolant when refilling.

Do not fill coolant above the “MAX” mark. Excess coolant will be forced out through the pressure relief valve in the cap when the engine becomes hot.

#### WARNING

- The cooling system is under pressure and can get very hot. Reduce the risk of scalding from hot coolant by following these steps.
- Turn off the engine and allow it to cool down.
- Protect your face, hands and arms from escaping fluid and steam by covering the cap with a large, thick rag.
- Turn the cap slowly and very carefully in a counter-clockwise direction while applying light, downward pressure on the top of the cap.

- To avoid being burned, do not spill antifreeze or coolant on the exhaust system or hot engine parts. Under certain conditions, the ethylene glycol in engine coolant can catch fire.
- Antifreeze is poisonous. Always store antifreeze in its original container and well out of the reach of children.
- If you drain the coolant, it must be caught and safely stored in a proper container clearly marked “poison”.

### ! Note

- Coolant pollutes the environment and could cause an engine fire. Excess coolant will be forced out through the pressure relief valve in the cap when the engine becomes hot.
- If, in an emergency, only water can be added, the correct ratio between water and antifreeze ⇒ *page 187* must be restored as soon as possible.

### 🌳 For the sake of the environment

Drained coolant should not be reused. Always dispose of used coolant while observing all environmental regulations.

## Radiator fan

*The radiator fan switches on automatically by itself.*

The electric radiator fan is controlled by thermostats that switch on and off depending on coolant and engine compartment temperatures.

An auxiliary electric radiator fan\* switches on and off depending on coolant temperature and other vehicle operation conditions.

After you switch the engine off, the auxiliary fan can continue running for up to 10 minutes - even with the ignition off. It can even switch on again later by itself ⇒ ⚠, if

- the temperature of the engine coolant rises due to the heat build-up from the engine in the engine compartment, or

- the engine compartment heats up because the vehicle is parked in intense sunlight.

### ⚠ WARNING

- To reduce the risk of personal injury never touch the radiator fan.
- The auxiliary electric fan is temperature controlled and can switch on suddenly even when the engine is not running.
- The auxiliary radiator fan switches on automatically when the engine coolant reaches a certain temperature and will continue to run until the coolant temperature drops.

## Brake fluid

### Checking brake fluid level

*The brake fluid level can be checked with a quick glance.*



**Fig. 139** Engine compartment: cover on the brake fluid reservoir

Before you check anything in the engine compartment, **always read and heed all WARNINGS** ⇒ ⚠ *in Working in the engine compartment on page 180.*

- ▶ Read the brake fluid level from the brake fluid reservoir ⇒ *page 182, fig. 134*. The brake fluid level must be between the “MIN” and “MAX” markings.

The brake fluid reservoir is located behind the rear partition of the engine compartment on the left side ⇒ *page 182*.

The fluid level may drop *slightly* after some time due to the automatic adjustment of the brake pads. This is not cause for alarm. ▶

If the brake fluid level falls *considerably* below the “MIN” mark, the brake warning/indicator light (U.S. models: **BRAKE**, Canadian models: ) will come on ⇒ *page 14*. Do not continue to operate the vehicle. The complete brake system should be thoroughly checked by an authorized Audi dealer or other qualified facility and the cause corrected. If the brake fluid level is too low, the brake warning/indicator light will illuminate. Contact an authorized Audi dealer **immediately**.

### Changing brake fluid

*Have the brake fluid changed by an experienced technician.*

Brake fluid absorbs moisture from the air. If the water content in the brake fluid is too high, corrosion in the brake system may result after a period of time. The boiling point of the brake fluid will also decrease considerably and decrease braking performance.

Therefore, the brake fluid must be changed **every two years**. Always use new brake fluid which conforms to Federal Motor Vehicle Standard “FMVSS 116 DOT 4”.

The brake fluid reservoir can be difficult to reach, therefore, we recommend that you have the brake fluid changed by your authorized **Audi dealer**. Your dealer has the correct tools, the right brake fluid and the know-how to do this for you.

#### **WARNING**

- Brake fluid is poisonous. It must be stored only in the closed original container out of the reach of children!
- Brake failure can result from old or inappropriate brake fluid. Observe these precautions:
  - Use only brake fluid that meets SAE specification J 1703 and conforms to Federal Motor Vehicle Standard 116. Always check with your authorized Audi dealer to make sure you are using the correct brake fluid. The correct type of

brake fluid is also indicated on the brake fluid reservoir.

- The brake fluid must be new. Heavy use of the brakes can cause a vapor lock if the brake fluid is left in the system too long. This can seriously affect the efficiency of the brakes as well as your safety. This could result in an accident.

#### **Note**

Brake fluid will damage the paint of your vehicle.

#### **For the sake of the environment**

Because of the problem of proper disposal of brake fluid as well as the special tools required and the necessary expertise, we recommend that you have the brake fluid changed by your authorized Audi dealer.

## Battery

### General information

Your vehicle is equipped with a special battery, an *AGM battery*. This battery is located in the luggage compartment and must be replaced with an original equipment battery. Under normal operating conditions, the battery is **maintenance-free**.

Have the battery checked when you take your vehicle in for service. You are well advised to replace a battery that is older than 5 years.

### Disconnecting the battery terminals

Some vehicle functions (power window regulators, for example) are lost if the battery terminals are disconnected. These functions have to be relearned after the battery terminals are connected again. To prevent this, the battery should only be disconnected from the vehicle electrical system when absolutely necessary for repairs.

### Vehicles not driven for long periods

If you do not drive your vehicle over a period of several days or weeks, electrical components are gradually cut back or switched off. ►

This reduces energy consumption and maintains starting capability over a longer period ⇒ *page 156*. Some of the convenience functions may not operate, such as the interior lights or power seat adjustment. The convenience functions will be available again when you switch on the ignition and start the engine.

### Winter operation

During the winter months, battery capacity tends to decrease as temperatures drop. This is because more power is also consumed while starting, and the headlights, rear window defogger, etc., are used more often.

Avoid unnecessary power consumption, particularly in city traffic or when traveling only short distances. Let your authorized Audi dealer check the capacity of the vehicle battery before winter sets in ⇒ *page 193*. A well charged battery will not only prevent starting problems when the weather is cold, but will also last longer.

### Replacing battery

The new battery **must have** the same capacity, voltage (12 volts), amperage, construction and plug sealing, as the original battery. Specifications are listed on the battery housing. Batteries specially developed by Audi fulfill the maintenance, output, and safety requirements.

When installing the battery, make sure the ignition and all electrical consumers are switched off ⇒ .

We recommend that you use maintenance-free or **cycle-resistant/leak-proof** batteries according to the standards TL 825 06 (from April 2008) and VW 7 50 73 (from April 2010).

Replacing the battery should be carried by a qualified workshop. Please follow the instructions on the battery cover.

### Note

- All work on the battery requires technical knowledge. Please contact an Audi dealership or another authorized facility for questions about the battery - danger of acid burns and explosion hazard!
- The battery must not be opened! Do not try to change the battery's liquid level, otherwise detonating gas will escape from the battery - explosion hazard!
- The AGM battery in the luggage compartment cannot leak, because the electrolyte for this battery is absorbed into a special glass mat. This leak-proof battery must not be replaced with a conventional battery.
- Make sure the ventilation hose on the side of the battery is connected, otherwise fumes or battery acid can leak out.
- Battery holder and terminals always have to be secured correctly.
- Before all work on the battery follow the **warnings** below ⇒  *in Working on the battery on page 192*.

### For the sake of the environment

Because of the problem of proper disposal of a battery, we recommend your authorized Audi dealer change the battery for you. Batteries contain sulfuric acid and lead and must always be disposed of properly in compliance with all environmental regulations. Disposing of vehicle batteries improperly is very dangerous to the environment. Make sure that the removed battery cannot overbalance, otherwise sulfuric acid might escape!

### Tips

If your vehicle is left standing for several weeks at extremely low temperatures, the vehicle battery should be removed and stored where it will not freeze. This will prevent it from being damaged and having to be replaced.

### Working on the battery





*Be especially careful when working on or near the battery!*

The battery is located in the luggage compartment under the floor. Before you work on or near the battery, **read and heed all WARNINGS** ⇨ .

Always heed the **safety warnings**, when working on the vehicle battery or the vehicle electrical system to prevent injury.

**The following WARNINGS are very important when working on the battery:**

**Always heed the following WARNING SYMBOLS and safety precautions when working on the battery.**

	<b>Always wear eye protection.</b>
	<b>Battery acid contains sulfuric acid. Always wear gloves and eye protection.</b>
	<b>No</b> - sparks - flames - smoking.
	<b>When a battery is charged, it produces hydrogen gas which is explosive and could cause personal injury.</b>
	<b>Always keep the battery well out of reach of children.</b>

### **WARNING**

Whenever working on the battery or on the electrical system, there is the risk of injury, accident and even fire. Read and heed the following WARNINGS:

- Always wear eye protection. Do not let battery acid or any lead particles get on your skin or clothing. Shield your eyes. Explosive gases can cause blindness or other injury.
- Battery acid contains sulfuric acid. Sulfuric acid can cause blindness and severe burns.
- Always wear gloves and eye protection. Do not tilt the battery because acid

could leak out of the ventilation openings.

- If you get battery acid in your eyes or on your skin, immediately rinse with cold water for several minutes and get medical attention.
- If you should ingest any battery acid, seek medical attention immediately.
- Do not expose the battery to an open flame, electric sparks or an open light.
- Do not smoke.
- Do not interchange the positive and negative cables.
- When working on the battery, be sure not to short-circuit the terminals with tools or other metal objects. This would cause the battery to heat up very quickly, which could lead to damage or explosion and personal injury.
- When a battery is charged, it produces hydrogen gas which is explosive and could cause personal injury.
- Always keep the battery well out of the reach of children.
- Before work is done on the electrical system, disconnect the negative ground cable.
- Before performing any work on the electrical system, switch off the engine and ignition as well as any electrical equipment. The negative cable on the battery must be disconnected. If you are just going to replace a light bulb, then it is enough to switch off the lights.
- Before disconnecting the battery, switch off the anti-theft alarm system! Otherwise you will set off the alarm.
- When disconnecting the battery, first disconnect the negative cable and then the positive cable.
- Before reconnecting the battery, make sure all electrical consumers are switched off. Reconnect the positive cable first and then the negative cable. Never interchange the cables - this could start a fire!
- Never charge a frozen or a thawed-out battery. It could explode! If a battery has frozen, then it must be replaced. A

discharged battery can freeze over at 32 °F (0 °C).

- Make sure the vent hose is always attached to the opening on the side of the battery.
- Never use batteries which are damaged. Danger of explosion! Always replace a damaged battery.

### WARNING

California Proposition 65 Warning:

- Battery posts, terminals and related accessories contain lead and lead compounds, chemicals known to the State of California to cause cancer and reproductive problems. Wash hands after handling.

### Note

- Do not disconnect the vehicle battery when the ignition is switched on or when the engine is running, otherwise, you will damage electronic components in the electrical system.
- If your vehicle is going to stand for a long period of time without being driven, protect the battery from “freezing”, otherwise it will be damaged and will then have to be replaced.

## Checking the battery acid level on magic eye batteries\*

The battery acid level in the battery can be checked through the clear inspection window.

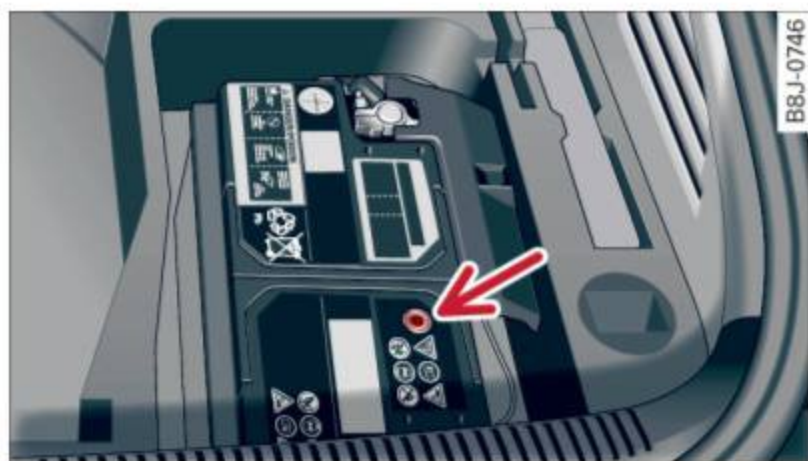



Fig. 140 Luggage compartment: Battery with magic eye.

On top of the battery, there is a round “window”. This window (magic eye) changes color as the battery charge and acid level change.

- ▶ Read and heed all WARNINGS ⇒  in *Working on the battery on page 192*
- ▶ Read the acid level from the window on the battery ⇒ *fig. 140*.

Air bubbles in the window can cause an inaccurate reading. Carefully tap on the side of the window.



- If the window is **green**, the battery acid level is correct.
- If the window has **no color** or is **bright yellow**, the battery acid level is too low. Have the battery tested by your authorized Audi dealer or a qualified workshop.
- If the window is **black**, then the battery is insufficiently charged. Recharge the battery as soon as possible ⇒ *page 193*.

### Note

Do not overfill the battery, otherwise battery acid will overflow through the vent opening. This can damage the paint and cause corrosion.

## Charging of battery

Starting the engine requires a well charged battery.

- ▶ **Always read and heed all WARNINGS** below ⇒  and ⇒  in *Working on the battery on page 192*.
- ▶ Switch off the ignition and all electrical consumers.
- ▶ Make sure the area is well ventilated when you charge the battery.
- ▶ Connect charger cables. **ALWAYS connect charger cables POSITIVE (+) to POSITIVE (+); NEGATIVE (-) to NEGATIVE (-)**.
- ▶ Switch on the charger.
- ▶ Turn off the charger ⇒ .
- ▶ Disconnect the charger cables.
- ▶ Connect both battery cables to the battery if necessary - *first plus, then minus*.

When charging at *low* voltages (e.g. with a **trickle charger**), the battery cables do not have to be disconnected first. Before charging at *high* voltages, i.e. “**fast charging**”, you must disconnect both cables. In either case, follow the instructions from the manufacturer of the charger.

Fastcharging a battery is **dangerous** ⇒ ⚠ in *Working on the battery on page 192*. It requires special charging equipment and the knowledge to go with it. We recommend having your battery fast charged only by a qualified workshop.

A discharged battery can **freeze** at temperatures of only 32 °F (0 °C). Allow a frozen battery to thaw completely before attempting to charge it ⇒ ⚠. However, we recommend not using a thawed battery again because the battery casing can be cracked due to ice formation and can leak battery acid.

Do not open the battery caps when charging the battery.

### ⚠ WARNING

Charging a battery can be dangerous.

- Never charge a frozen battery. It may explode because of gas trapped in the ice. Allow a frozen battery to thaw out first.
- Do not reuse batteries which were frozen. The battery housing may have cracked and weakened when the battery froze.
- Charge the battery in a well ventilated area. Keep away from open flame or electrical spark. Do not smoke. Hydrogen gas generated by the battery is explosive.
- To reduce the danger of explosion, never connect or disconnect charger cables while the charger is operating.
- Fast charging a battery is dangerous and should only be attempted by a competent technician with the proper equipment.
- Battery acid that may spill during charging should be washed off with a solution of warm water and baking soda to neutralize the acid.

### ! Note

Never use a fast charger as a booster to start the engine. This will seriously damage sensitive electronic components, such as control units, relays, radio, etc., as well as the battery charger.

### i Tips

The vehicle battery must not be charged with a standard small charger that plugs into the cigarette lighter or outlet.

## Windshield/headlight washer container



Fig. 141 Fender, left: cover on the windshield and headlight\* washer fluid reservoir

The washer fluid container is marked with the symbol 🚿 on its cap ⇒ *page 182, fig. 134*.

- ▶ Before you check anything in the engine compartment, **always read and heed all WARNINGS** ⇒ ⚠ in *Working in the engine compartment on page 180*.
- ▶ Lift the filler cap tongue to add washer fluid. You can fill the container to the top.
- ▶ Press the cap back onto the filler neck after filling the container.

You can find the reservoir **capacity** in the table in ⇒ *page 240*

Clean water should be used when filling up. If possible, use soft water to prevent scaling on the washer jets. Always add a glass cleaner solution (with frost protection in the winter). ▶

**!** Note

- Do not mix engine coolant antifreeze or any other additives to fill up the windshield washer reservoir.
- Do not use glass cleaners containing paint solvent; you risk damaging the paint.

## Tires and wheels

### Tires

#### General notes

*Tires may be the least appreciated and most abused parts of a motor vehicle.*

Tires may be the least appreciated and most abused parts of a motor vehicle. Tires are, however, one of the most important parts of a vehicle, particularly considering the comparatively small patch of rubber on each tire that assures that all-important contact between you, your vehicle and the road.

Maintaining the correct tire pressure, making sure that your vehicle and its tires do not have to carry more weight than they can safely handle, avoiding damage from road hazards and regularly inspecting tires for damage including cuts, slashes irregular wear and overall condition are the most important things that you can do to help avoid sudden tire failure including tread separation and blowouts.

#### Avoiding damage

If you have to drive over a curb or similar obstacle, drive very slowly and as close as possible at a right angle to the curb.

Always keep chemicals including grease, oil, gasoline and brake fluid off the tires.

Inspect the tires regularly for damage (cuts, cracks or blisters, etc.). Remove any foreign bodies embedded in the treads.

#### Storing tires

Mark tires when you remove them to indicate the direction of rotation. This ensures you to be able to mount them correctly when you re-install them.

When removed, the wheels or tires should be stored in a cool, dry and preferably dark place.

Store tires in a vertical position if they are not mounted on rims, in a horizontal position if they are mounted on rims.

#### New tires

New tires have to be broken in ⇒ .

The tread depth of new tires may vary, according to the type and make of tire and the tread pattern.

#### Hidden damage

Damage to tires and rims is often not readily visible. If you notice unusual vibration or the vehicle pulls to one side, this may indicate that one of the tires has been damaged. The tires must be checked immediately by an authorized Audi dealer or qualified workshop.

#### Unidirectional tires

A unidirectional tire can be identified by arrows on the sidewall, that point in the direction the tire is designed to rotate. You must follow the specified direction of rotation. This is necessary so that these tires can develop their optimum characteristics regarding grip, road noise, wear and hydroplaning resistance. For more information ⇒ *page 227*.



#### WARNING

New tires or tires that are old, worn or damaged cannot provide maximum control and braking ability.

- New tires tend to be slippery and must be broken in. To reduce the risk of losing control, a collision and serious personal injuries, drive with special care for the first 350 miles (560 km).
- Driving with worn or damaged tires can lead to loss of control, sudden tire failure, including a blowout and sudden deflation, crashes and serious personal injuries. Have worn or damaged tires replaced immediately.
- Tires age even if they are not being used and can fail suddenly, especially at high speeds. Tires that are more than 6 years old can only be used in an emergency and then with special care and at low speed.

- Never mount used tires on your vehicle if you are not sure of their “previous history.” Old used tires may have been damaged even though the damage cannot be seen that can lead to sudden tire failure and loss of vehicle control.
- If you notice unusual vibration or if the vehicle pulls to one side when driving, always stop as soon as it is safe to do so and check the wheels and tires for damage.

### Note

Please note that summer and winter tires are designed for the conditions that are

typical in those seasons. Audi recommends using winter tires during the winter months. Low temperatures significantly decrease the elasticity of summer tires, which affects traction and braking ability. If summer tires are used in very cold temperatures, cracks can form on the tread bars, resulting in permanent tire damage that can cause loud driving noise and unbalanced tires. Audi is not responsible for this type of damage.

## Glossary of tire and loading terminology

### Accessory weight

means the combined weight (in excess of those standard items which may be replaced) of automatic transmission, power steering, power brakes, power windows, power seats, radio, and heater, to the extent that these items are available as factory-installed equipment (whether installed or not).

### Aspect ratio

means the ratio of the height to the width of the tire in percent. Numbers of 55 or lower indicate a low sidewall for improved steering response and better overall handling on dry pavement.

### Bead

means the part of the tire that is made of steel wires, wrapped or reinforced by ply cords and that is shaped to fit the rim.

### Bead separation

means a breakdown of the bond between components in the bead.

### Cord

means the strands forming the plies in the tire.

### Cold tire inflation pressure

means the tire pressure recommended by the vehicle manufacturer for a tire of a designated size that has not been driven for more than a couple of miles (kilometers) at low speeds in the three hour period before the tire pressure is measured or adjusted.

### Curb weight

means the weight of a motor vehicle with standard equipment including the maximum capacity of fuel, oil, and coolant, air conditioning and additional weight of optional equipment.

### Extra load tire

means a tire designed to operate at higher loads and at higher inflation pressures than the corresponding standard tire. Extra load tires may be identified as “XL”, “xl”, “EXTRA LOAD”, or “RF” on the sidewall.

### Gross Axle Weight Rating (“GAWR”)

means the load-carrying capacity of a single axle system, measured at the tire-ground interfaces.

### Gross Vehicle Weight Rating (“GVWR”)

means the maximum total loaded weight of the vehicle.

**Groove**

means the space between two adjacent tread ribs.

**Load rating (code)**

means the maximum load that a tire is rated to carry for a given inflation pressure. You may not find this information on all tires because it is not required by law.

**Maximum load rating**

means the load rating for a tire at the maximum permissible inflation pressure for that tire.

**Maximum loaded vehicle weight**

means the sum of:

- (a) Curb weight
- (b) Accessory weight
- (c) Vehicle capacity weight, and
- (d) Production options weight

**Maximum (permissible) inflation pressure**

means the maximum cold inflation pressure to which a tire may be inflated. Also called “maximum inflation pressure.”

**Normal occupant weight**

means 150 lbs. (68 kilograms) times the number of occupants seated in the vehicle up to the total seating capacity of your vehicle.

**Occupant distribution**

means distribution of occupants in a vehicle.

**Outer diameter**

means the overall diameter of an inflated new tire.

**Overall width**

means the linear distance between the exteriors of the sidewalls of an inflated tire, including elevations due to labeling, decorations, or protective bands or ribs.

**Ply**

means a layer of rubber-coated parallel cords.

**Production options weight**

means the combined weight of those installed regular production options weighing over 5 lbs. (2.3 kg) in excess of those standard items which they replace, not previously considered in curb weight or accessory weight, including heavy duty brakes, ride levelers, roof rack, heavy duty battery, and special trim.

**Radial ply tire**

means a pneumatic tire in which the ply cords that extend to the beads are laid at substantially 90 degrees to the centerline of the tread.

**Recommended inflation pressure**

see ⇒ *page 197, Cold tire inflation pressure.*

**Reinforced tire**

means a tire designed to operate at higher loads and at higher inflation pressures than the corresponding standard tire. Reinforced tires may be identified as “XL” , “xl” , “EXTRA LOAD” , or “RF” on the sidewall.

**Rim**

means a metal support for a tire or a tire and tube assembly upon which the tire beads are seated.

**Rim diameter**

means nominal diameter of the bead seat. If you change your wheel size, you will have to purchase new tires to match the new rim diameter.

**Rim size designation**

means rim diameter and width.

**Rim width**

means nominal distance between rim flanges.

**Sidewall**

means that portion of a tire between the tread and bead. ►

**Speed rating (letter code)**

means the speed at which a tire is designed to be driven for extended periods of time. The ratings range from 93 mph (150 km/h) to 186 mph (298 km/h) ⇒ *page 208*. You may not find this information on all tires because it is not required by law.

The speed rating letter code, where applicable, is molded on the tire sidewall and indicates the maximum permissible road speeds ⇒  *in Winter tires on page 212*.

**Tire pressure monitoring system**

means a system that detects when one or more of a vehicle's tires are underinflated and illuminates a low tire pressure warning tell-tale.

**Tread**

means that portion of a tire that comes into contact with the road.

**Tread separation**

means pulling away of the tread from the tire carcass.

**Treadwear indicators (TWI)**

means the projections within the principal grooves designed to give a visual indication of the degrees of wear of the tread. See ⇒ *page 206, Tread Wear Indicator (TWI)* for more information on measuring tire wear.

**Uniform Tire Quality Grading**

is a tire information system developed by the United States National Highway Traffic Safety Administration (NHTSA) that is designed to help buyers make relative comparisons among tires. The UTQG is not a safety rating and not a guarantee that a tire will last for a prescribed number of miles or perform in a certain way. It simply gives tire buyers additional information to combine with other considerations,

such as price, brand loyalty and dealer recommendations. Under UTQG, tires are graded by the tire manufacturers in three areas: treadwear, traction and temperature resistance. The UTQG information on the tires, molded into the sidewalls.

**U.S. DOT Tire Identification Number (TIN)**

This is the tire's "serial number" It begins with the letters "DOT" and indicates that the tire meets all federal standards. The next two numbers or letters indicate the plant where it was manufactured, and the last four numbers represent the week and year of manufacture. For example,

**DOT ... 2211 ...**

means that the tire was produced in the 22nd week of 2011. The other numbers are marketing codes that may or may not be used by the tire manufacturer. This information is used to contact consumers if a tire defect requires a recall.

**Vehicle capacity weight**

means the rated cargo and luggage load plus 150 lbs. (68 kilograms) times the vehicle's total seating capacity as listed on the label located on the driver's side B-pillar.

**Vehicle maximum load on the tire**

means that load on an individual tire that is determined by distributing to each axle its share of the maximum loaded vehicle weight and dividing by two.

**Vehicle normal load on the tire**

means that load on an individual tire that is determined by distributing to each axle its share of the curb weight, accessory weight, and normal occupant weight (distributed in accordance with table below ⇒ *page 200*) and dividing by two. ▶

## Occupant loading and distribution for vehicle normal load for various designated seating capacities

Designated seating capacity, number of occupants	Vehicle normal load, number of occupants	Occupant distribution in a normally loaded vehicle
4	2	2 in front

### Cold tire inflation pressure

*Tire pressure affects the overall handling, performance and safety of a vehicle.*

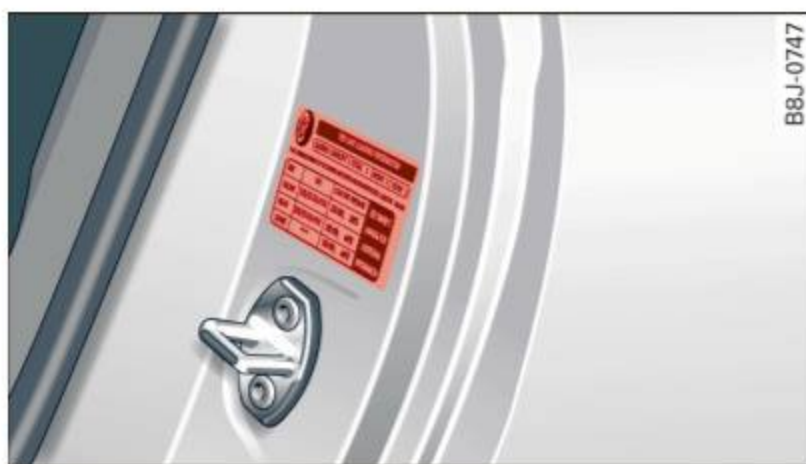

Fig. 142 Tire pressure label: located on driver's side B-pillar

Tire pressure generally refers to the amount of air in a tire that it needs it to do its job and safely carry the combined load of the entire vehicle and its contents. Tire pressure is measured in kilopascals (kPa), the international measuring unit and in pounds per square inch (PSI). Tire pressure is based in part on the vehicle's design and load limit – the greatest amount of weight that the vehicle can carry safely and the tire size. The proper tire pressure is frequently referred to as the “recommended cold tire inflation pressure.” Air in the tires expands when the tire heats up because of internal friction when it flexes in use. The tire pressure is higher when the tire has warmed up than when it is “cold.” It is the inflation pressure in a “cold” tire that counts. Therefore, you should never let air out of a warm tire to match “cold tire inflation pressure” recommendations. The tires would then be underinflated and could fail suddenly.

Maintaining proper tire pressure is one of the most important things you can do to help avoid sudden tire failure. Underinflated tires are a major cause of sudden tire failure. Keeping tires at the right pressure is also important for safe and responsive vehicle handling,

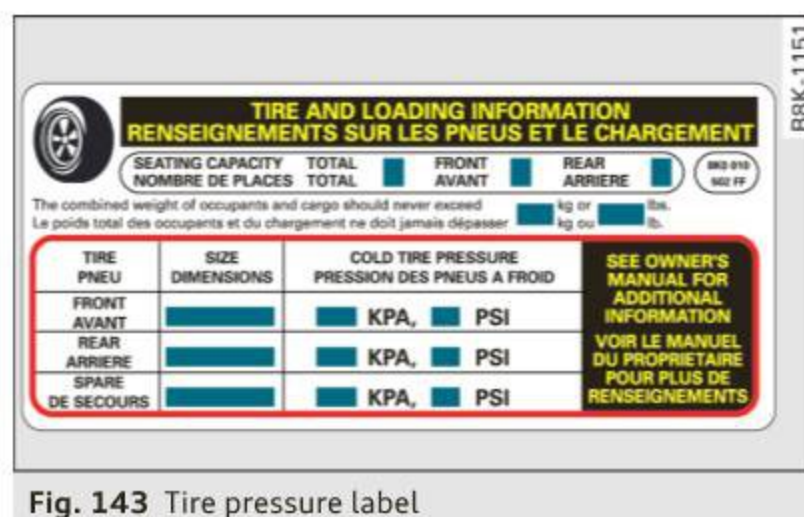

Fig. 143 Tire pressure label

traction, braking and load carrying. **Tire pressures are particularly important when the vehicle is being driven at higher speeds, and then especially when heavily loaded even within the permissible load-carrying capacities approved for your vehicle.**

The recommended tire pressures for your Audi depend on the kind of tires on your vehicle and the number of passengers and/or amount of luggage you will be transporting.

The tire pressure label is located on the driver's side B-pillar. The tire pressure label lists the recommended cold tire inflation pressures for the vehicle at its maximum capacity weight and tires that were on your vehicle at the time it was manufactured.

**If you wish to improve comfort when operating the vehicle at normal load (up to 2 occupants), you can adjust tire pressures to those specified for normal vehicle load. Before operating the vehicle at maximum load, you must increase the tire pressures to those specified for maximum vehicle load ⇒ ⚠.**

Bear in mind that the tire pressure monitoring system can only monitor the tire pressures

you have stored. The system does not recognize the load condition of your vehicle.

The effectiveness of the tire pressure monitoring system will be impaired if you store normal load pressures but then operate the vehicle at its maximum load ⇒ ⚠.

See the illustration ⇒ *fig. 142* for the location of the label on driver's side B-pillar (color of the actual label and exact location on the vehicle will vary slightly).

Note that the following table is accurate at the time of going to press and is subject to

change. In the event of discrepancies, the tire pressure label (on driver's side B-pillar) always takes precedence.

The table below lists the recommended cold tire inflation pressures for the Audi model covered by your Owner's Literature at the vehicle's capacity weight and the tire sizes installed on the respective models as original equipment, or as a factory option.

Model/ Engine	Tire designation	Tire pressure front				Tire pressure rear			
		normal load condition (up to 2 occupants)		full load condition		normal load condition (up to 2 occupants)		full load condition	
		PSI	kPA	PSI	kPA	PSI	kPA	PSI	kPA
TT/TTS: 2.0 liter 4-cylinder	225/50 R17 94H All Season	32	220	32	220	29	200	29	200
	225/50 R17 94W XL High Performance	32	220	32	220	29	200	29	200
	245/45 R17 95H All Season	32	220	32	220	29	200	29	200
	245/45 R17 95Y XL High Performance	32	220	32	220	29	200	29	200
	245/40 R18 93H All Season	32	220	32	220	29	200	29	200
	245/40 R18 93Y XL High Performance	32	220	33	230	29	200	30	210
	255/35 R19 96Y XL High Performance	32	220	32	220	29	200	29	200
TT RS: 2.5 liter 5-cylinder	245/40 R18 93Y	35	240	36	250	32	220	32	220
	255/35 R19 96Y XL High Performance	35	240	36	250	32	220	32	220

**XL = reinforced or extra load tire. It may also appear as xl, EXTRA LOAD, or RF on the tire sidewall.**

The correct tire pressure for the *spare wheel* is located on a label on the driver's side B-pillar.

Because technical changes may be made to vehicle equipment during the model year, always compare the tire size designation on the

tire pressure label on your vehicle with the tires on your vehicle. Make sure that the tire size information on the vehicle label is the same as the size of the tires on the vehicle. This is especially important if the vehicle belongs to someone else or you bought the

vehicle with different rims/tires or you bought the vehicle as a previously owned vehicle.

Remember, your safety and that of your passengers also depends on making sure that load limits are not exceeded. Vehicle load includes everybody and everything in and on the vehicle. These load limits are technically referred to as the vehicle's Gross Vehicle Weight Rating ("GVWR"). The Gross Axle Weight Rating ("GAWR") is the maximum load that can be applied at each of the vehicle's two axles. The Gross Vehicle Weight Rating and the Gross Axle Weight Rating are listed on the safety compliance sticker label located on the driver's side B-pillar. The tire pressure label on your Audi lists the maximum combined weight of all of the occupants and luggage or other cargo that the vehicle can carry. For the location of the tire pressure label ⇒ *fig. 142*.

### WARNING

Overloading a vehicle can cause loss of vehicle control, a crash or other accident, serious personal injury, and even death.

- Carrying more weight than your vehicle was designed to carry will prevent the vehicle from handling properly and increase the risk of a loss of vehicle control.
- The brakes on a vehicle that has been overloaded may not be able to stop the vehicle within a safe distance.
- Tires on a vehicle that has been overloaded can fail suddenly causing loss of control and a crash.

### WARNING

- Incorrect tire pressures and/or underinflation can lead to a serious or fatal accident.
- Incorrect tire pressures and/or underinflation cause increased tire wear and can affect the handling of the vehicle.
- Incorrect tire pressures and/or underinflation can also lead to sudden tire failure, including a blowout and sudden deflation, causing loss of vehicle control.

### Checking tire pressure

*The correct tire pressure for the tires originally installed on your vehicle is listed on the tire pressure label located on driver's side B-pillar.*

The recommended tire pressures are on the tire pressure label and in the table ⇒ *page 200, Cold tire inflation pressure*. This means that the pressure must be checked and adjusted when the tire has not been driven for more than a couple of miles (kilometers) at low speeds during the previous three hours. Air in the tires expands when the tire heats up as a result of internal friction as it flexes in use. The tire pressure is higher when the tire has warmed up than when it is "cold."

It is the inflation pressure in a "cold" tire that counts. Therefore, you should never let air out of a warm tire to match "Cold tire inflation pressure" recommendations ⇒ *page 200*. The tires would then be underinflated and could fail suddenly.

The tire pressure label on your Audi lists the recommended cold tire inflation pressures for the new, original equipment tires that were on your vehicle at the time it was manufactured. For the location of the label ⇒ *page 200, fig. 142*.

Most tires lose air naturally over time. They can also lose some air if you drive over a pothole or hit a curb while parking. It is usually not possible to see whether the radial tires used today are underinflated just by looking at them.

Therefore, be sure to check tire pressures at least once a month and always before going on a long trip. Make sure to take the number of people and the amount of luggage into account when adjusting tire pressure for a trip – even one that you would not consider to be "long." See ⇒ *page 204, Tires and vehicle load limits* for more important information.

Always use an accurate tire pressure gauge when checking and adjusting inflation pressures. Check all of the tires and be sure not to ►

forget the spare tire. If the pressure in any tire is too high when the tire is “cold,” let air out of the tire slowly with the edge of the tire gauge and keep checking the pressure until you reach the pressure that is correct for the load (passengers and luggage) and kind of driving you plan to do.

If the pressure in any tire is too low, note the difference between the pressure in the cold tire and the pressure you need and add the air that you need to reach the correct pressure for the vehicle load (passengers and luggage) for the tires on your vehicle as listed on the on your vehicle and in this manual and the kind of driving you plan to do.

**Never exceed the maximum inflation pressure listed on the tire sidewall for any reason.**

Remember that the vehicle manufacturer, not the tire manufacturer, determines the correct tire pressure for the tires on your vehicle.

It is important to check the tire pressure when the tires are cold.

- Read the required tire pressure from the tire pressure label located on driver’s side B-pillar.
- Turn the valve stem cap counter-clockwise to remove it from the tire valve.
- Place the air pressure gauge on the valve.
- The tire pressures should only be checked and adjusted when the tires are cold. The slightly raised pressures of warm tires must not be reduced.
- Adjust the tire pressure to the load you are carrying.
- Reinstall the valve stem cap on the valve.

#### **When should I check the tire pressure?**

The correct tire pressure is especially important at high speeds. The pressure should therefore be checked at least once a month and always before starting a journey.

#### **When should I adjust the tire pressures?**

Adjust the tire pressure to the load you are carrying. After changing a wheel **or** replacing

wheels you have to adjust the tire pressures on all wheels. In addition, you must then initialize the new tire pressures in the tire pressure monitoring system ⇒ *page 214*.

#### **WARNING**

Incorrect tire pressures and/or underinflation can lead sudden tire failure, loss of control, collision, serious personal injury or even death.

- When the warning symbol  appears in the instrument cluster, stop and inspect the tires.
- Incorrect tire pressure and/or underinflation can cause increased tire wear and can affect the handling of the vehicle and stopping ability.
- Incorrect tire pressures and/or underinflation can also lead to sudden tire failure, including a blowout and sudden deflation, causing loss of vehicle control.
- The driver is responsible for the correct tire pressures for all tires on the vehicle. The applicable pressure values are located on a sticker on the driver’s side B-pillar.
- Only when all tires on the vehicle are filled to the correct pressure, the tire pressure monitoring system can work correctly.
- The use of incorrect tire pressure values can lead to accidents or other damage. Therefore it is essential that the driver observe the specified tire pressure values for the tires and the correct pressures for the function of the tire pressure monitoring system.
- Always inflate tires to the recommended and correct tire pressure before driving off.
- Driving with underinflated tires bend more, letting them get too hot resulting in tread separation, sudden tire failure and loss of control.
- Excessive speed and/overloading can cause heat build-up, sudden tire failure and loss of control.

- If the tire pressure is too low or too high, the tires will wear prematurely and the vehicle will not handle well.
- If the tire is not flat and you do not have to change a wheel immediately, drive at reduced speed to the nearest service station to check the tire pressure and add air as required.

### Note

Driving without valve stem caps can cause damage to the tire valves. To prevent this, always make sure that factory installed valve stem caps on all wheels are securely mounted on the valve.

### For the sake of the environment

Underinflated tires will also increase the fuel consumption.

## Tires and vehicle load limits

There are limits to the amount of load or weight that any vehicle and any tire can carry. A vehicle that is overloaded will not handle well and is more difficult to stop. Overloading can not only lead to loss of vehicle control, but can also damage important parts of the vehicle and can lead to sudden tire failure, including a blowout and sudden deflation that can cause the vehicle to crash.

Your safety and that of your passengers also depends on making sure that load limits are not exceeded. Vehicle load includes everybody and everything in and on the vehicle. These load limits are technically referred to as the vehicle's **Gross Vehicle Weight Rating** ("GVWR").

The "GVWR" includes the weight of the basic vehicle, all factory installed accessories, a full tank of fuel, oil, coolant and other fluids plus maximum load. The maximum load includes the number of passengers that the vehicle is intended to carry ("seating capacity") with an assumed weight of 150 lbs (68 kg) for each passenger at a designated seating position

and the total weight of any luggage in the vehicle.

The **Gross Axle Weight Rating** ("GAWR") is the maximum load that can be applied at each of the vehicle's two axles.

The Gross Vehicle Weight Rating and the Gross Axle Weight Rating are listed on the safety compliance sticker label located on the driver's side B-pillar. Your Audi has 4 seating positions, 2 in the front and 2 in the rear for total seating capacity of 4. Each seating position has a safety belt ⇒ *page 100, Safety belts*.

The fact that there is an upper limit to your vehicle's Gross Vehicle Weight Rating means that the total weight of whatever is being carried in the vehicle is limited. The more passengers in the vehicle or passengers who are heavier than the standard weights assumed mean that less weight can be carried as luggage.

The tire pressure label on your Audi also lists the maximum combined weight of all of the occupants and luggage or other cargo that the vehicle can carry. For the location of the label ⇒ *page 200, fig. 142*.

### WARNING

Overloading a vehicle can cause loss of vehicle control, a crash or other accident, serious personal injury, and even death.

- Carrying more weight than your vehicle was designed to carry will prevent the vehicle from handling properly and increase the risk of the loss of vehicle control.
- The brakes on a vehicle that has been overloaded may not be able to stop the vehicle within a safe distance.
- Tires on a vehicle that has been overloaded can fail suddenly, including a blowout and sudden deflation, causing loss of control and a crash.

### Determining correct load limit

Use the example below to calculate the total weight of the passengers and luggage or other things that you plan to transport so that you can make sure that your vehicle will not be overloaded.

### Steps for Determining Correct Load Limit

1. Locate the statement “THE COMBINED WEIGHT OF OCCUPANTS AND CARGO SHOULD NEVER EXCEED XXX KG OR XXX LBS” on your vehicle’s placard (tire inflation pressure label) ⇒ *page 200, fig. 142.*
2. Determine the combined weight of the driver and passengers that will be riding in your vehicle.
3. Subtract the combined weight of the driver and passengers from “XXX” kilograms or “XXX” pounds shown on the sticker ⇒ *page 200, fig. 142.*
4. The resulting figure equals the available amount of cargo and luggage load capacity. For example, if the “XXX” amount equals 1400 lbs. and there will be five 150 lbs. passengers in your vehicle, the amount of available cargo and luggage load capacity is 650 lbs. ( $1400 - 750$  ( $5 \times 150$ ) = 650 lbs.)
5. Determine the combined weight of luggage and cargo being loaded on the vehicle. That weight may not safely exceed the available cargo and luggage load capacity calculated in Step 4.
6. If your vehicle will be towing a trailer, load from your trailer will be transferred to your vehicle. Consult this manual to determine how this reduces the available cargo and luggage load capacity of your vehicle.
  - ▶ Check the tire sidewall (⇒ *page 207, fig. 146*) to determine the designated load rating for a specific tire.

### Tire service life

The service life of tires depends on a lot of different things including proper installation and balancing, correct tire pressure and driving style.



Fig. 144 Tire tread: tread wear indicators (TWI)

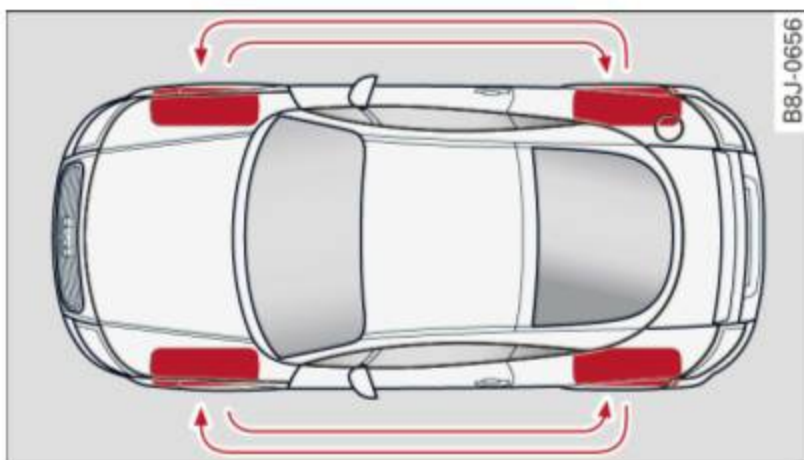

Fig. 145 Rotating tires for more even wear

### Tread Wear Indicator (TWI)

The original tires on your vehicle have 1/16 inch (1.6 mm) high “wear indicators” ⇒ *fig. 144* running across the tread. Depending on the make, there will be six to eight of them evenly placed around the tire. Marks on the tire sidewall (for example “TWI” or other symbols) indicate the positions of the tread wear indicators. Worn tires must be replaced. Different figures may apply in other countries ⇒ ⚠.

### Tire pressure

Incorrect tire pressure causes premature wear and can cause sudden tire blow-out. For this reason, tire pressure must be checked at least once a month ⇒ *page 202*.

### Driving style

Driving fast around curves, heavy acceleration and hard braking increase tire wear.

### Rotating tires for more even wear

For all four tires on your vehicle to have the same service life, we recommend that the front and rear tires are rotated according to the tire manufacturer's suggested tire rotation intervals. Please remember the following:

- Tire rotation intervals may differ from the vehicle service intervals outlined in your Warranty & Maintenance Booklet.
- The longer one tire is used in one location on the vehicle, the more it wears at certain points; therefore, we recommend that you follow the tire manufacturer's suggested tire rotation intervals.
- Vehicles with front-wheel drive experience more tread wear on the front wheels compared to all-wheel drive (quattro®).
- Please rotate tires as shown ⇒ *fig. 145*.
- Extra care must be taken when rotating direction-specific tires ⇒ *page 227*.

### Wheel balancing

The wheels on new vehicles are balanced. However, various situations during everyday driving can cause them to become unbalanced, resulting in vibrations you can usually feel through the steering wheel.

Unbalanced wheels must be rebalanced to avoid excessive wear on steering, suspension and tires. A wheel must also be rebalanced when a new tire is installed.

### Incorrect wheel alignment

Incorrect wheel alignment can cause excessive tire wear, impairing the safety of the vehicle. If tires show excessive wear, have the wheel alignment checked by an authorized Audi dealer or qualified workshop.

### all-wheel drive

Vehicles with quattro® must always have tires of the same size, construction and tread type. For details see ⇒ *page 155*. ▶

## ! WARNING

- Sudden tire failure can lead to loss of control, a crash and serious personal injury!
- Never drive a vehicle when the tread on any tire is worn down to the wear indicators.
  - Worn tires are a safety hazard, they do not grip well on wet roads and increase your risk of “hydroplaning” and loss of control.
  - Always keep chemicals that can cause tire damage, such as grease, oil, gasoline and brake fluid away from tires.
  - Tires age even if they are not being used and can fail suddenly, especially at high speeds. Tires that are more than 6 years old can only be used in an emergency and then with special care and at lower speeds.
  - Never mount used tires on your vehicle if you are not sure of their “previous history.” Old used tires may have been damaged even though the damage cannot be seen that can lead to sudden tire failure and loss of vehicle control.

## New tires and replacing tires and wheels

*New tires and wheels have to be broken in.*

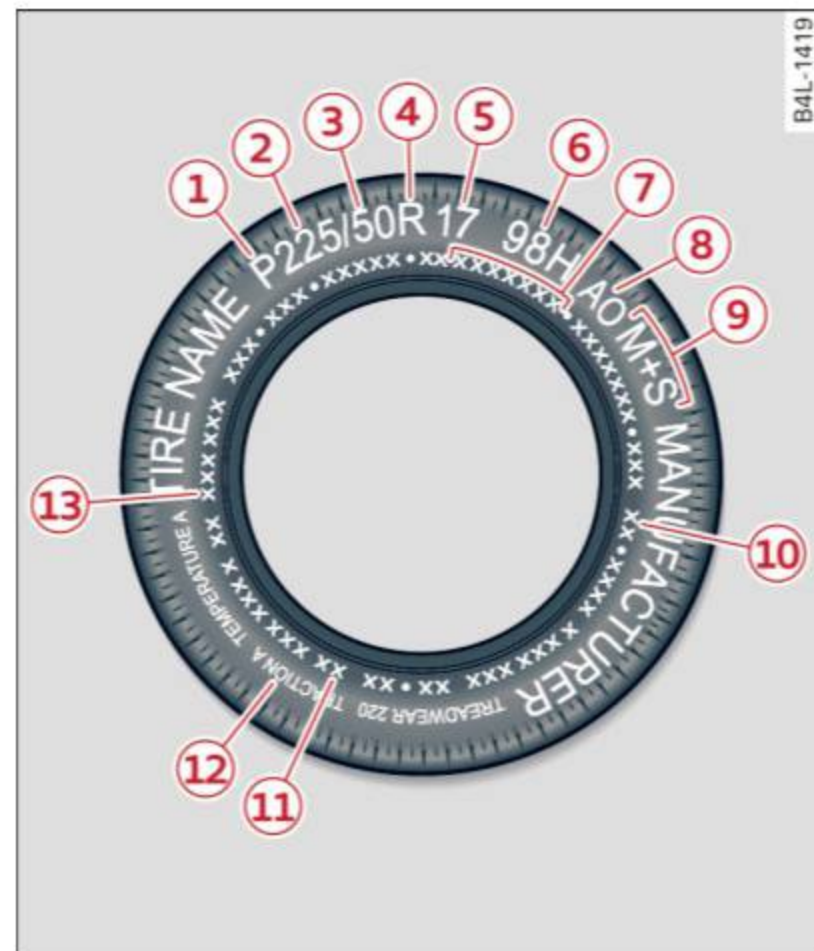

**Fig. 146** Tire specification codes on the sidewall of a tire

No.	Description
①	Passenger car tire (where applicable)
②	Nominal width of tire in millimeters
③	Ratio of height to width (aspect ratio)
④	Radial
⑤	Rim diameter code
⑥	Load index and speed rating
⑦	U.S. DOT tire identification number
⑧	Audi Original tire
⑨	Sever snow conditions
⑩	Tire ply composition and materials used
⑪	Maximum load rating
⑫	Treadwear, traction and temperature grades
⑬	Maximum permissible inflation pressure

The tires and rims are essential parts of the vehicle's design. The tires and rims approved by Audi are specially matched to the characteristics of the vehicle and can make a major contribution to good road holding and safe

handling when in good condition and properly inflated ⇒ .

We recommend that all work on tires and wheels be performed by an authorized Audi dealer. They are familiar with recommended procedures and have the necessary special tools and spare parts as well as the proper facilities for disposing of the old tires.

Authorized Audi dealers have the necessary information about technical requirements for installing or changing tires and rims.

### Replacing tires and wheels

Tires should be replaced at least in pairs and not individually (for example both front tires or both rear tires together).

Be sure to read and heed the information to the tire pressure monitoring system ⇒ *page 214*.

Always buy replacement radial tires that have the same specifications as the tires approved for your vehicle by Audi. Replacement tires must always have the same load rating specification as the original equipment or approved optional tires listed in the table ⇒ *page 200*.

Audi-approved specification tires are specially matched to your vehicle and its load limits, and can contribute to the important roadholding, driving characteristics, and safety of the vehicle. The table (⇒ *page 200*) lists specifications of the tires approved for the Audi models covered by your Owner's Literature.

The tire pressure label located on driver's side B-pillar (⇒ *page 200, fig. 143*) lists the specifications of the original equipment tires installed on your vehicle at the time it was manufactured.

Federal law requires tire manufacturers to place standardized information on the sidewall of all tires ⇒ *fig. 146*. This information identifies and describes the fundamental characteristics, the quality grade of the tire and also provides a tire identification number for safety standard certification and in case of a recall.

### Tire specifications

Knowledge of tire specifications makes it easier to choose the correct tires. Radial tires have the tire specifications marked on the sidewall, for example:

#### **P245 / 45 R 17 95 H**

This contains the following information:

- P** Indicates the tire is for passenger cars
- 245** Nominal tire width in mm of the tire from sidewall edge to sidewall edge. In general, the larger the number, the wider the tire
- 45** Height/width ratio in percent (aspect ratio)
- R** Tire construction: **Radial**
- 17** Rim diameter code (in inches)
- 95** Load rating code
- H** Speed rating letter code
- XL** (or "xl", "EXTRA LOAD", or "RF") indicates that the tire is a "Reinforced" or an "Extra Load" tire
- M+S** (or "M/S") Indicates that the tire has some mud and snow capability

The tires could also have the information of direction of rotation ⇒ *page 196*.

### Tire manufacturing date

The manufacturing date is also indicated on the tire sidewall (possibly only on the *inner* side of the wheel):

"DOT ... 2211..." means, for example, that the tire was produced in the 22nd week of 2011.

### Speed rating (letter code)

The speed rating letter code on the wheels indicates the maximum permissible road speeds ⇒  in *Winter tires on page 212*.

- P** up to 93 mph (150 km/h)
- Q** up to 99 mph (158 km/h)
- R** up to 106 mph (170 km/h)
- S** up to 110 mph (180 km/h)
- T** up to 118 mph (190 km/h)
- U** up to 124 mph (200 km/h)
- H** up to 130 mph (210 km/h)



- V up to 149 mph (240 km/h)<sup>1)</sup>
- Z over 149 mph (240 km/h)<sup>1)</sup>
- W up to 168 mph (270 km/h)<sup>1)</sup>
- Y up to 186 mph (298 km/h)<sup>1)</sup>

Your vehicle is normally factory equipped with tires, which possess excellent driving characteristics and give your Audi optimum driving comfort. An electronic speed limiter ⇒ *page 31* will normally prevent your vehicle from going faster than the tire speed rating ⇒ .

### U.S. DOT Tire Identification Number (TIN) and tire manufacture date

This is the tire's "serial number". It begins with the letters "DOT" and indicates that the tire meets all federal standards. The next two numbers or letters indicate the plant where it was manufactured, and the last four numbers represent the week and year of manufacture. For example, the numbers 2211 mean that the tire was produced in the 22nd week of 2011. The other numbers are marketing codes that may or may not be used by the tire manufacturer. This information is used to contact consumers if a tire defect requires a recall.

### Audi Original tire

Tires with the identification "AO" or "RO" have been specially matched with your Audi. We recommend using only these tires because they meet the highest standards regarding safety and driving characteristics when used correctly. Your authorized Audi dealer will gladly provide you with more information.

### Tire ply composition and materials used

The number of plies indicates the number of layers of rubber-coated fabric in the tire. In general, the greater the number of plies, the more weight a tire can support. Tire manufacturers also must indicate the materials in the

tire, which include steel, nylon, polyester, and others.

### Maximum Load Rating

This number indicates the maximum load in kilograms and pounds that can be carried by the tire.

### Tire quality grading for treadwear, traction, and temperature resistance

Tread wear, traction and temperature grades ⇒ *page 210*.

### Maximum Permissible Inflation Pressure

This number is the greatest amount of air pressure that should ever be put in the tire under normal driving conditions.



### WARNING

- Using incorrect or unmatched tires and / or wheels or improper tire and wheel combinations can lead to loss of control, collision and serious personal injury.
- Always use tires, rims and wheel bolts that meet the specifications of original factory-installed tires or other combinations that have been specifically approved by the vehicle manufacturer.
- Tires age even if they are not being used and can fail suddenly, especially at high speeds. Tires that are more than 6 years old can only be used in an emergency and then with special care and at lower speeds.
- Never mount used tires on your vehicle if you are not sure of their "previous history." Old used tires may have been damaged even though the damage cannot be seen that can lead to sudden tire failure and loss of vehicle control.
- All four wheels must be fitted with radial tires of the same type, size (rolling circumference) and the same tread pattern.

<sup>1)</sup> For tires with a maximum speed capability over 149 mph (240 km/h), tire manufacturers sometimes use the letters "ZR."

Driving with different tires reduces vehicle handling and can lead to a loss of control.

- If the spare tire is not the same as the tires that are mounted on the vehicle - for example with winter tires - only use the spare tire for a short period of time and drive with extra care. Refit the normal road wheel as soon as safely possible.
- Never drive faster than the maximum speed for which the tires on your vehicle are rated because tires that are driven faster than their rated speed can fail suddenly.
- Overloading tires cause heat build-up, sudden tire failure, including a blowout and sudden deflation and loss of control.
- Temperature grades apply to tires that are properly inflated and not over or underinflated.
- For technical reasons it is not always possible to use wheels from other vehicles - in some cases not even wheels from the same vehicle model.
- If you install wheel trim discs on the vehicle wheels, make sure that the air flow to the brakes is not blocked. Reduced air-flow to the brakes can lead them to overheat, increasing stopping distances and causing a collision.
- Run flat tires may only be used on vehicles that were equipped with them at the factory. The vehicle must have a chassis designed for run flat tires and a factory-installed tire pressure monitoring system that indicates a loss of tire pressure. Incorrect use of run flat tires can lead to vehicle damage or accidents. Check with an authorized Audi dealer or tire specialist to see if your vehicle can be equipped with run flat tires. If run flat tires are used, they must be installed on all four wheels. Mixing tire types is not permitted.

### Note

- For technical reasons, it is not generally possible to use the wheel rims from other vehicles. This can hold true for wheels of the same vehicle type.
- If the spare tire is different from the tires that you have mounted on your vehicle (for example winter tires or wide profile tires), then use the spare tire for a short period of time only and drive with extra care. Replace the flat tire with the tire matching the others on your vehicle as soon as possible.
- Never drive without the valve stem cap. The valves could get damaged.

### For the sake of the environment

Dispose of old tires in accordance with the local requirements.

## Uniform tire quality grading

- Tread wear
- Traction AA A B C
- Temperature A B C

Quality grades can be found where applicable on the tire side wall between tread shoulder and maximum section width ⇒ *page 207, fig. 146.*

**For example:** Tread wear **200**, Traction **AA**, Temperature **A**.

All passenger car tires must conform to Federal Safety Requirements in addition to these grades.

### Tread wear

The *tread wear* grade is a comparative rating based on the wear rate of the tire when tested under controlled conditions on a specified government test course.

For example, a tire graded 150 would wear one and one half (1 1/2) times as well on the government course as a tire graded 100. ▶

The relative performance of tires depends upon the actual conditions of their use, however, and may depart significantly from the norm due to variations in driving habits, service practices and differences in road characteristics and climate.

### Traction

The *traction* grades, from highest to lowest, are AA, A, B and C. Those grades represent the tire's ability to stop on wet pavement as measured under controlled conditions on specified government test surfaces of asphalt and concrete. A tire marked C may have poor traction performance ⇒ ⚠.

### Temperature

The *temperature* grades are A (the highest), B, and C, representing the tire's resistance to the generation of heat and its ability to dissipate heat when tested under controlled conditions on a specified indoor laboratory test wheel.

Sustained high temperature can cause the material of the tire to degenerate and reduce tire life, and excessive temperature can lead to sudden tire failure ⇒ ⚠.

The grade C corresponds to a level of performance which all passenger car tires must meet under the Federal Motor Vehicle Safety Standard No. 109. Grades B and A represent higher levels of performance on the laboratory test wheel than the minimum required by law.

#### WARNING

The traction grade assigned to this tire is based on straight-ahead braking traction tests, and does not include acceleration, cornering, hydroplaning or peak traction characteristics.

#### WARNING

The temperature grade for this tire is established for a tire that is properly inflated and not overloaded. Excessive speed, underinflation, or excessive loading, either

separately or in combination, can cause heat buildup and possible tire failure.

### Winter tires

*Winter tires can improve vehicle handling on snow and ice. At temperatures below 45 °F (7 °C) we recommend changing to winter tires.*

In some heavy snow areas, local governments may require true winter or “snow” tires, those with very deeply cut tread. These tires should only be used in pairs and be installed on all four wheels. Make sure you purchase snow tires that are the same size and construction type as the other tires on your vehicle.

If your vehicle is equipped with all-wheel drive\*, this will improve traction during winter driving, even with the standard tires. However, we strongly recommend that you always equip all four wheels on your vehicle with correctly fitted winter tires or all-season tires, when winter road conditions are expected. This also improves the vehicle's braking performance and reduces stopping distances.

Summer tires provide less grip on ice and snow.

Winter tires (snow tires) must always be fitted on all four wheels.

Ask your authorized Audi dealer or qualified workshop for permitted **winter tire sizes**. Use only radial winter tires.

Winter tires lose their effectiveness when the tread is worn down to a depth of 0.157 inch (4 mm).

Only drive with winter tires under winter conditions. Summer tires handle better when there is no snow or ice on the roads and the temperature is above 45 °F (7 °C).

If you have a flat tire, see notes on spare wheel ⇒ *page 207*.

Please always remember that winter tires may have a lower speed rating than the tires originally installed on your vehicle at the time it

was manufactured. Please see ⇒ *page 208*, *Speed rating (letter code)* for a listing of the speed rating letter codes and the maximum speed at which the tires can be driven.

The speed rating letter code (⇒ *page 199*) is on the side wall of the tire ⇒ *page 207*.

### WARNING

Winter tires have maximum speed limits that may be lower than your vehicle's maximum speed. Always know the maximum speed before driving off. Never drive faster than the speed permitted for your specific winter tires. This will cause damage to the tires leading to an accident and serious personal injury to you and your passengers.

### WARNING

Driving faster than the maximum speed for which the winter tires on your vehicle were designed can cause tire failure including a blowout and sudden deflation, loss of control, crashes and serious personal injuries. Have worn or damaged tires replaced immediately.

- Winter tires have maximum speed rating that may be lower than your vehicle's maximum speed.
- Never drive faster than the speed for which the winter or other tires installed on your vehicle are rated.

### WARNING

Always adjust your driving to the road and traffic conditions. Never let the good acceleration of the winter tires and all-wheel drive tempt you into taking extra risks. Always remember:

- When braking, an all-wheel drive vehicle handles in the same way as a front drive vehicle.
- Drive carefully and reduce your speed on icy and slippery roads, even winter tires cannot help under black ice conditions.



### For the sake of the environment

Use summer tires when weather conditions permit. They are quieter, do not wear as quickly and reduce fuel consumption.

## Snow chains

Snow chains may be fitted only to the front wheels, and only to certain tire sizes. Ask your authorized Audi dealer on which tire sizes snow chains can be used.

If you are going to use snow chains, then you must install them on the front wheels at least.

The snow chains must have low-profile links and must not be thicker than 0.53 inch (13.5 mm), including the lock.

Remove wheel center covers and trim discs before putting snow chains on your vehicle ⇒ . For safety reasons cover caps must then be fitted over the wheel bolts. These are available from authorized Audi dealers.



### WARNING

Using the wrong snow chains for your vehicle or installing them incorrectly can increase the risk of loss of control leading to serious personal injury.

- Snow chains are available in different sizes. Always make sure to follow the instructions provided by the snow chain manufacturer.
- When driving with snow chains never drive faster than the speed permitted for your specific snow chains.
- Always observe local regulations.



### Note

- Remove snow chains before driving on roads not covered with snow to avoid damaging tires and wearing the snow chains down unnecessarily.
- Snow chains, which come into direct contact with the wheel rim, can scratch or damage it. Therefore, make sure that the

snow chains are suitably covered. Check the position of the snow chains after driving a few yards and correct if necessary. Follow the instructions from the snow chain manufacturer when doing so.

### Tips

Where snow chains are mandatory on certain roads, this normally also applies to vehicles with all-wheel drive.

## Wheel bolts

*Wheel bolts must always be tightened to the correct torque.*

The design of wheel bolts is matched to the factory installed rims. If different rims are fitted, the correct wheel bolts with the right length and correctly shaped bolt heads must be used. This ensures that wheels are fitted securely and that the brake system functions correctly.

In certain circumstances, you may not use wheel bolts from a different vehicle – even if it is the same model ⇒ *page 245*.

### WARNING

Improperly tightened or maintained wheel bolts can become loose causing loss of control, a collision and serious personal injury.

- Always keep the wheel bolts and the threads in the wheel hubs clean so the wheel bolts can turn easily and be properly tightened.
- Never grease or oil the wheel bolts and the threads in the wheel hubs. They can become loose while driving if greased or oiled, even if tightened to the specified torque.
- Only use wheel bolts that belong to the rim being installed.
- Never use different wheels bolts on your vehicle.
- Always maintain the correct tightening torque for the wheel bolts to reduce the risk of a wheel loss. If the tightening tor-

que of the wheel bolts is too low, they can loosen and come out when the vehicle is moving. If the tightening torque is too high, the wheel bolts and threads can be damaged and the wheel can become loose.

### Note

The specified torque for the wheel bolts is 90 ft lb (120 Nm) with a tolerance of  $\pm 7,4$  ft lb ( $\pm 10$  Nm). Torque wheel bolts diagonally. After changing a wheel, the torque must be checked as soon as possible with a torque wrench – preferably by an authorized Audi dealer or qualified workshop.

## Low aspect ratio tires

Your Audi is factory-equipped with low aspect ratio tires. These tires have been thoroughly tested and been selected specifically for your model for their superb performance, road feel and handling under a variety of driving conditions. Ask your authorized Audi dealer for more details.

The low aspect ratio of these tires is indicated by a numeral of **55 or less** in the tire's size designation. The numeral represents the ratio of the tire's sidewall height in relation to its tread width expressed in percentage. Conventional tires have a height/width ratio of 60 or more.

**The performance of low-aspect-ratio tires is particularly sensitive to improper inflation pressure. It is therefore important that low aspect ratio tires are inflated to the specified pressure and that the inflation pressure is regularly checked and maintained. Tire pressures should be checked at least once a month and always before a long trip** ⇒ *page 202, Checking tire pressure*.

### What you can do to avoid tire and rim damage

Low aspect ratio tires can be damaged more easily by impact with potholes, curbs, gullies ▶

or ridges on the road, particularly if the tire is underinflated.

In order to minimize the occurrence of impact damage to the tires of your vehicle, we recommend that you observe the following precautions:

- Always maintain recommended inflation pressures. Check your tire pressure every 2,000 miles (3,000 km) and add air if necessary.
- Drive carefully on roads with potholes, deep gullies or ridges. The impact from driving through or over such obstacles can damage your tires. Impact with a curb may also cause damage to your tires.
- After any impact, immediately inspect your tires or have them inspected by the nearest authorized Audi dealer. Replace a damaged tire as soon as possible.
- Inspect your tires every 2,000 miles (3,000 km) for damage and wear. Damage is not always easy to see. Damage can lead to loss of air and underinflation, which could eventually cause tire failure. If you believe that a tire may have been damaged, replace the tire as soon as possible.
- These tires may wear more quickly than others.
- Please also remember that, while these tires deliver responsive handling, they may ride less comfortably and make more noise than other choices.

### **Reduced performance in winter/cold season conditions**

All tires are designed for certain purposes. The low aspect ratio, ultra high performance tires originally installed on your vehicle are intended for maximum dry and wet road performance and handling. They are not suitable for cold, snowy or icy weather conditions. If you drive under those circumstances, you should equip your vehicle with all-season or winter tires, which offer better traction under those conditions. We suggest you use the recommended snow or all-season tires specified for your vehicle, or their equivalent.

Refer to ⇒ *page 211* for more detailed information regarding winter tires.

## **Tire pressure monitoring system**

### **General notes**

Applies to vehicles: with tire pressure monitoring system

Each tire, including the spare (if provided), should be checked monthly when cold and inflated to the inflation pressure recommended by the vehicle manufacturer on the vehicle placard or tire inflation pressure label. (If your vehicle has tires of a different size than the size indicated on the vehicle placard or tire inflation pressure label, you should determine the proper tire inflation pressure for those tires.)

As an added safety feature, your vehicle has been equipped with a tire pressure monitoring system (TPMS) that illuminates a low tire pressure telltale when one or more of your tires is significantly under-inflated. Accordingly, when the low tire pressure telltale illuminates, you should stop and check your tires as soon as possible, and inflate them to the proper pressure. Driving on a significantly under-inflated tire causes the tire to overheat and can lead to tire failure. Under-inflation also reduces fuel efficiency and tire tread life, and may affect the vehicle's handling and stopping ability.

Please note that the TPMS is not a substitute for proper tire maintenance, and it is the driver's responsibility to maintain correct tire pressure, even if under-inflation has not reached the level to trigger illumination of the TPMS low tire pressure telltale.

Your vehicle has also been equipped with a TPMS malfunction indicator to indicate when the system is not operating properly. The TPMS malfunction indicator is combined with the low tire pressure telltale. When the system detects a malfunction, the telltale will flash for approximately one minute and then ►

remain continuously illuminated. This sequence will continue upon subsequent vehicle start-ups as long as the malfunction exists.

When the malfunction indicator is illuminated, the system may not be able to detect or signal low tire pressure as intended. TPMS malfunctions may occur for a variety of reasons, including the installation of replacement or alternate tires or wheels on the vehicle that prevent the TPMS from functioning properly. Always check the TPMS malfunction telltale after replacing one or more tires or wheels on your vehicle to ensure that the replacement or alternate tires and wheels allow the TPMS to continue to function properly.

### Tire pressure indicator appears

Applies to vehicles: with tire pressure monitoring system

*The tire pressure indicator in the instrument cluster informs you if the tire pressure is too low or if there is a system malfunction.*

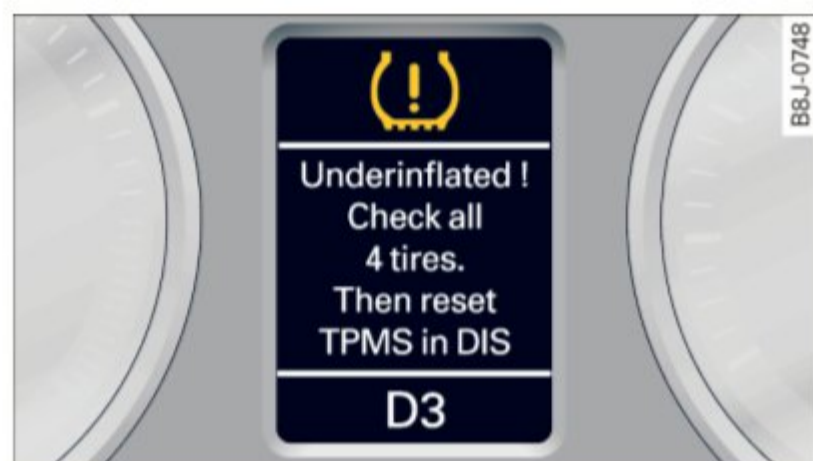



Fig. 147 Display: underinflation warning

Using the ABS sensors, the tire pressure monitoring system compares the tire tread circumference and vibration characteristics of the individual tires. If the pressure decreases in one or more tires, this is indicated in the instrument cluster with a warning symbol  and a message  $\Rightarrow$  fig. 147. The driver message in the display goes out after 5 seconds. The driver message can be displayed again by pressing the **CHECK** button   $\Rightarrow$  page 10, fig. 3. If only one tire is affected, the display will indicate its position.



The tire pressure monitoring must be reset in the menu display each time the pressures are adjusted (e. g. when switching between parti-

al and full load pressure) or after changing or replacing a tire on your vehicle  $\Rightarrow$  page 216. The TPMS indicator only monitors the tire pressure that you have previously stored. You can find the recommended tire pressures for your vehicle on the label on the driver's door pillar  $\Rightarrow$  page 200.

Tire tread circumference and vibration characteristics can change and cause a tire pressure warning if:

- the tire pressure in one or more tires is too low,
- the tire has structural damage,
- the tire pressure was changed, wheels rotated or replaced but the TPMS was not reset  $\Rightarrow$  page 216.

### Warning symbols

 Loss of pressure in at least one tire  $\Rightarrow$  . Check the tire or tires and replace or repair if necessary. The indicator light  in the instrument cluster also illuminates  $\Rightarrow$  page 13. Check/correct the pressures of all four tires and reset TPMS in the menu display.

**TPMS** (Tire Pressure Monitoring System) **Tire pressure! System malfunction.** If **TPMS** appears after switching the ignition on or while driving and the indicator light  in the instrument cluster blinks for approximately one minute and then stays on, there is a system malfunction.

Attempt to store the correct tire pressure  $\Rightarrow$  page 216. If the indicator light does not turn off or if it turns on shortly thereafter, immediately drive your vehicle to an authorized Audi dealer or authorized repair facility to have the malfunction corrected.

### WARNING

- If the tire pressure indicator appears in the instrument cluster display, one or more of your tires is significantly underinflated. Reduce your speed immediately and avoid any hard steering or braking maneuvers. Stop as soon as possible and check the tires and their pressures.

Inflate the tire pressure to the proper pressure as indicated on the vehicle's tire pressure label ⇒ *page 200*. Driving on a significantly under-inflated tire causes the tire to overheat and can lead to tire failure. Under-inflation also is likely to impair the vehicle's handling and stopping ability.

- The driver is responsible for maintaining the correct tire pressures. You must check the tire pressures regularly.
- Under certain conditions (such as a sporty driving style, winter conditions or unpaved roads), the pressure monitor indicator may be delayed.
- Ask your authorized Audi dealer if run-flat tires may be used on your vehicle. Your vehicle registration becomes invalid if you use these tires when not permitted. Damage to your vehicle or accidents could also result.
- If you switch between standard and run-flat tires, an authorized Audi dealer or qualified workshop must reprogram the control module.

### **i** Tips

- The tire pressure monitoring system stops working when there is an ESC/ABS malfunction.
- Using snow chains may result in a system malfunction.
- The tire pressure monitoring system on your Audi was developed using tires with the “AO” or “RO” identification on the tire sidewall ⇒ *page 207*. We recommend using these tires.

## Reset tire pressure monitoring system (Step1)

Applies to vehicles: with tire pressure monitoring system

*If the tire pressure is adjusted, wheels are rotated or changed, the TPMS must be reset in the menu display.*



Fig. 148 Wiper lever: Controls for the menu display



Fig. 149 Display: Start menu

**Reset** button (B) and **rocker switch** (A)  
⇒ *fig. 148* functions:

### To open the menu

- ▶ Press the **Reset** button (B) until the menu display ⇒ *fig. 149* appears

### Selections and settings

- ▶ Press the rocker switch (A) to reach a menu display. The switch is operated the same as the display (up/down).

### Entering and confirming

- ▶ Press the **Reset** button (B).

### Returning to the Start menu

- ▶ Press the **Reset** button longer than 2 seconds to return from any menu level to the Start menu.

**i** Tips

- Before resetting the TPMS, the current pressures of **all four tires** must correspond to the specified values. Adjust the tire pressure and reset the pressure in the tire pressure monitoring system according to the load you are carrying ⇒ *page 200*.
- Do not store the tire pressure if there are snow chains on the tire.

**Reset tire pressure monitoring system (Step2)**

Applies to vehicles: with tire pressure monitoring system



Fig. 150 Display: Tire pressure



Fig. 151 Display: Tire pressure

**Reset** button **(B)** and **rocker switch (A)**  
⇒ *page 216, fig. 148* functions:

**Storing tire pressures**

- ▶ Turn on the ignition.
- ▶ Select the menu: > **Adjusting\*** > **Tire pressure** > **Store**.

**Entering and confirming**

- ▶ Select the menu: Store now
- ▶ Press the **Reset** button **(B)**.
- ▶ Select the menu: Confirm
- ▶ Press the **Reset** button **(B)**.

**Returning to the Start menu**

- ▶ Press the **Reset** button longer than 2 seconds to return from any menu level to the Start menu.

**i** Tips

- Before resetting the TPMS, the current pressures of **all four tires** must correspond to the specified values. Adjust the tire pressure and reset the pressure in the tire pressure monitoring system according to the load you are carrying ⇒ *page 200*.
- Do not store the tire pressure if there are snow chains on the tire.

**Run-flat tires****Introduction**

Applies to vehicles: with Run-flat tires

*Run-flat tires help keep you moving if a tire goes flat.*

Reinforced sidewalls give the tires run-flat capability if tire pressure is lost.

We recommend that run-flat tires only be mounted on vehicles that were originally equipped with these special tires at the factory and have a **Tire Pressure Monitoring System**.

**Run-flat tires can be identified by the letters "RSC" on the tire sidewall.**

If you do change the tires on your vehicle from normal to run-flat tires, you must buy the special rims required for run-flat tires, and the **Tire Pressure Monitoring System** must be re-programmed by an authorized Audi dealer or other qualified workshop.

**What do run-flat tires do?**

These special tires have run-flat capabilities that help keep you moving if a tire loses pressure and goes flat. Under favorable conditions tires can be driven **at least 30 miles (50 km)**, but you must not drive **faster than 50 mph (80 km/h)** ⇒ *page 218, Driving with run-flat tires*.

### When it is not possible to continue driving, even with run-flat tires?

- If the Electronic Stabilization Control (ESC) is not working or keeps coming on.
- If the **Tire Pressure Monitoring System** does not work.
- If the tire has been severely damaged, in a crash, for example. The tread can separate from a damaged tire as the wheel turns, and hit parts of the vehicle, such as the fuel tank filler neck, fuel lines or brake lines.
- Do not continue driving if severe vibration occurs or if the tire starts to smoke because the tire is running hot.
- Do not continue driving if damage to the tire, such as cracks in the sidewall, appears.

#### **WARNING**

Improper use of run-flat tires can cause vehicle damage that can lead to loss of vehicle control, a crash and serious personal injury.

- Run-flat tires can only be used with special rims.
- Run-flat tires must always be monitored with a properly programmed **Tire Pressure Monitoring System**.
- Always inspect a tire that has lost air to make sure it is safe to drive with the tire in the run-flat mode.
- Never drive with run-flat tires that have been damaged in a collision.
- Never drive with run-flat tires if heat build-up causes the tire to give off smoke.
- Never drive with run-flat tires if the vehicle shakes or vibrates severely.
- Never drive with a run-flat tire that develops sidewall cracks or other damage while in use.
- If you switch between standard and run-flat tires, an authorized Audi dealer or qualified workshop must reprogram the control module.

#### **Note**

Run-flat tires have special characteristics and requirements, that are very different from conventional tires. Run-flat tires require special rims for run-flat use and cannot be used on conventional wheel rims.

#### **Tips**

- If you are not able to continue driving with run-flat tires, please seek professional assistance.
- Please contact your authorized Audi dealer or Audi of America, Inc. if you have questions about tires and rims.

### Driving with run-flat tires

Applies to vehicles: with Run-flat tires

*Handling characteristics change when tire pressure is low.*

Driving on tires with low tire pressure changes the way a vehicle handles, particularly when cornering and braking. The handling characteristics of run-flat tires do not seem to change a lot even when driving on low pressure or in the run-flat mode. Nevertheless you must still take special precautions when operating a vehicle on run-flat tires when tire pressure is low or the tire(s) is flat:

- ▶ The Electronic Stabilization Control (ESC) must be switched on.
- ▶ Never drive faster than 50 mph (80 km/h) ⇒ .
- ▶ Plan ahead when driving and anticipate what you will have to do considering traffic and road conditions up ahead.
- ▶ Accelerate carefully.
- ▶ Avoid unnecessary and sudden steering and braking maneuvers.
- ▶ Reduce your speed in plenty of time before intersections, curves and other places where you may have to react quickly.

Please see: ⇒ page 218, *When it is not possible to continue driving, even with run-flat tires?*

### Handling characteristics change when driving with low air pressure or with flat tires even with special run-flat tires

A low pressure or flat **front tire** affects vehicle handling characteristics by pulling the vehicle slightly to the side where the tire is mounted and reduces braking performance.

A low pressure or flat **rear tire** also affects driving characteristics by pulling to the side where the tire is mounted and also reduces braking performance. The effect on vehicle handling is most noticeable when driving around curves.

#### **WARNING**

Changed vehicle handling characteristics when driving in the run-flat mode can cause loss of vehicle control, a crash and serious personal injury.

- Driving on special run-flat tires in the run-flat mode will change vehicle handling characteristics during braking, when cornering and under heavy acceleration.
- Never drive faster than the maximum rated speed of 50 mph (80 km/h) when driving in the run-flat mode.
- Always adjust vehicle speed to traffic, road and weather conditions and drive slower than the maximum rated speed if necessary weather and road conditions are taken into account.
- Always obey speed limits and other traffic laws.

#### **Note**

We always recommend driving with even more care when using these special tires in the run-flat mode. Always avoid sudden maneuvers.

### Replacing run-flat tires and rims

Applies to vehicles: with Run-flat tires

*Your vehicle was especially designed to use special run-flat tires.*

You may use and combine only approved run-flat tires and special matching rims that have been designed for run-flat tires. Mounting special run-flat tires on standard wheels will not work and will not provide the advantages for the run-flat feature. Never use special run-flat tires on standard wheel rims.

After driving with a tire in the run-flat mode, always have the vehicle and affected tire(s) and rim(s) inspected by an authorized Audi dealer. Tires that have been driven in the run-flat mode must be replaced.

#### **WARNING**

Use of damaged run-flat tires and rims can cause vehicle damage that can lead to loss of vehicle control, a crash and serious personal injury.

- Always have the vehicle and affected tire(s) and rim(s) inspected by an authorized Audi dealer after driving a tire in the run-flat mode.
- Tires that have been driven in the run-flat mode must be replaced.

## What do I do now?

### Vehicle tool kit

The tools are stored underneath the floor panel in the luggage compartment.

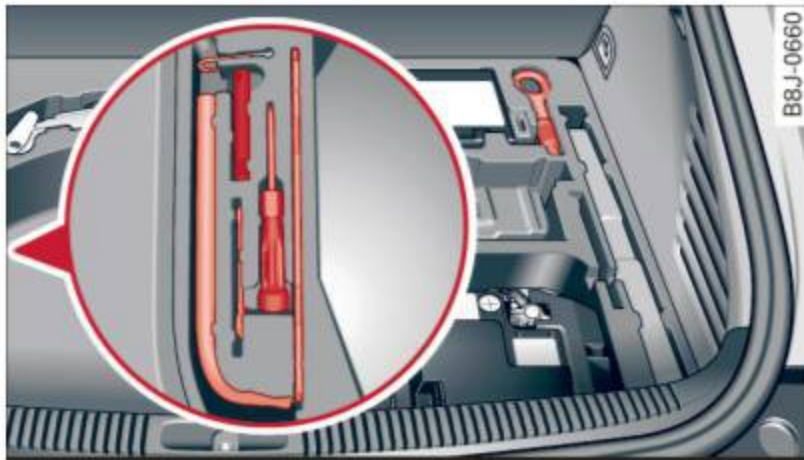

Fig. 152 Luggage compartment: vehicle tool kit

- ▶ Swing the luggage compartment floor upwards.
- ▶ Remove the vehicle tool kit.

The onboard tool kit includes:

- Hook for removing wheel covers\*
- Plastic clip to remove wheel bolt covers\*
- Wheel bolt wrench
- Alignment pin for changing wheels
- Screwdriver with reversible blade
- Replacement bit (reversible Torx bit for changing lamps)
- Open ended wrench 10 x 13
- Towing eye
- Jack\*

Some of the onboard items listed above are provided on certain models only or are optional extras.

Before returning the jack\* to its place, retract the jack arm fully.



#### WARNING

Improper use of the vehicle jack can cause serious personal injuries.

- Never use the screw driver hex head to tighten wheel bolts, since the bolts cannot attain the necessary tightening torque if you use the hex head, potentially causing an accident.

- The factory-supplied jack is intended only for your vehicle model. Under no circumstances should it be used to lift heavy vehicles or other loads; you risk injuring yourself.
- Never start the engine when the vehicle is raised, which could cause an accident.
- Support the vehicle securely with appropriate stands if work is to be performed underneath the vehicle; otherwise, there is a potential risk for injury.
- Never use the jack supplied with your Audi on another vehicle, particularly on a heavier one. The jack is only suitable for use on the vehicle it came with.

## Tire repair

### General and safety pointers

Applies to vehicles: with Tire Mobility System

*Tire repair is intended only for temporary, short-term use.*



Fig. 153 Tire damage for which the Tire Mobility System is not suited

Your vehicle is equipped with a tire repair kit, the **Tire Mobility System (TMS)**.

In the event of a tire failure, the **TMS** is in the luggage compartment under the floor. It consists of the tire sealant and an electric air pump.

Using **TMS**, tire damage caused by foreign bodies up to about **0.16 inch (4 mm)** in diameter can be sealed reliably.

The foreign object can stay in the tire. ▶

**The tire sealant must not be used:**

- for cuts or punctures in the tire which are larger than 0.16 inch (4 mm) ⇒ *fig. 153* ①
- for damage to the rim ②
- if you have been driving with very low tire pressures or tires with no air ③

Using the **TMS** is described in the section ⇒ *page 221, Preliminary steps.*

**TMS** can be used at temperatures down to  $-4\text{ }^{\circ}\text{F}$  ( $-20\text{ }^{\circ}\text{C}$ ).

**! WARNING**

Take the following precautions after repairing the tire:

- Do not drive faster than 50 mph (80 km/h)!
- Avoid full-throttle acceleration, heavy braking and fast cornering.
- The vehicle's road behavior can be affected.
- Tires sealed with **TMS** are intended only for **temporary, short-term** use.
- After using the tire sealant the tire pressure monitoring system may no longer work properly. Drive carefully to the next professional repair facility.
- **TMS** must **NOT** be used,
  - for cuts or punctures in the tire which are larger than 0.16 inch (4 mm)
  - for damage to the rim
  - if you have been driving with very low tire pressures or tires with no air
- Seek professional assistance if it is not possible to repair the tire with the tire sealant.

**! WARNING**

The tire sealant must not come into contact with skin, eyes or clothing.

- If you get any tire sealant in your eyes or come into contact with it, rinse the affected area thoroughly with clean water. Find a physician immediately!
- Change any clothing contaminated with tire sealant immediately.
- Do not inhale the vapor!

- If you have swallowed tire sealant, rinse your mouth thoroughly right away and drink plenty of water.
  - Do not induce vomiting! Find a physician immediately!
- If you have allergic reactions, find a physician immediately.
- Keep the tire sealant away from children.

**! Note**

Do not use commercially available tire sealants. The electrical components of the tire pressure monitoring system will no longer work properly.

**🌱 For the sake of the environment**

Used sealant bottles can be dropped off at a recycling facility.

**i Tips**

- If sealant has run out, allow it to dry. Then you can peel it off.
- Have the tire sealant replaced every 4 years at a dealership.

**Preliminary steps**

Applies to vehicles: with Tire Mobility System

*Some preliminary steps are necessary for tire repair.*

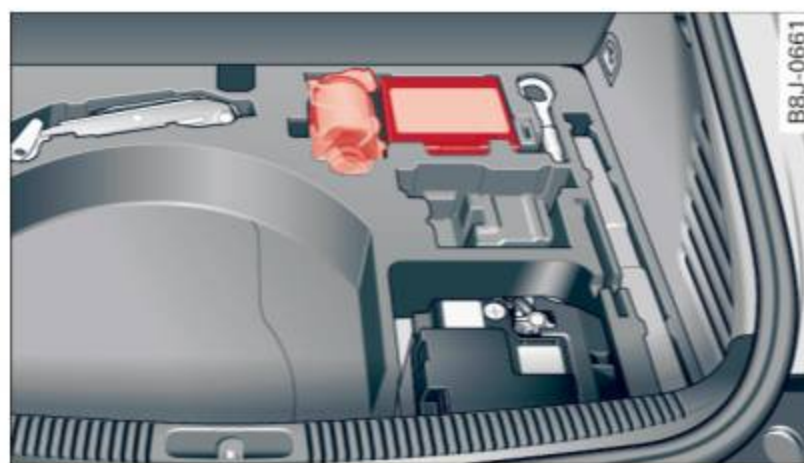

**Fig. 154** Luggage compartment: Tire Mobility System

- ▶ If you have a flat tire, park the vehicle as far as possible from moving traffic.
- ▶ Apply the **parking brake** firmly.
- ▶ Shift into **1st gear** on vehicles with manual transmission, or move the **selector lever to the P position** on vehicles with automatic transmission.

- ▶ Check whether a repair using the Tire Mobility System is possible ⇒ *page 220, General and safety pointers.*
- ▶ Have all passengers **leave** the vehicle and stay away from the danger zone ⇒ .
- ▶ Take the **sealant bottle** and the **electric air pump** from the luggage compartment under the floor ⇒ *fig. 154.*
- ▶ Remove the “max. 50 mph” (80 km/h) sticker from the sealant bottle and affix it to the instrument cluster in the driver's view.

### WARNING

- Turn the hazard flashers on and set up the warning triangle if you have a flat tire in moving traffic. In this way you protect yourself and other road users.
- Make sure that all passengers are in a safe place, out of the danger zone (for example, behind a guard rail).

### Note

Particular care is necessary if you are making a tire repair on a steep incline.

### Tips

Obey all laws.

## Making a tire repair

Applies to vehicles: with Tire Mobility System

*Tire repair consists of the following sections.*

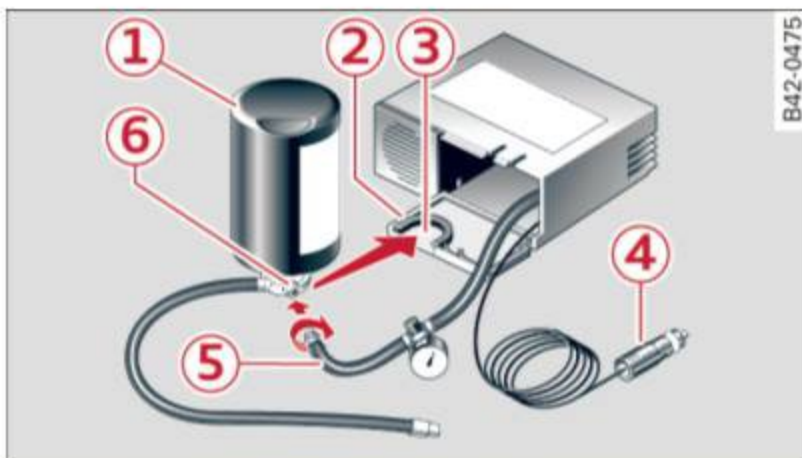

Fig. 155 Parts of the Tire Mobility System

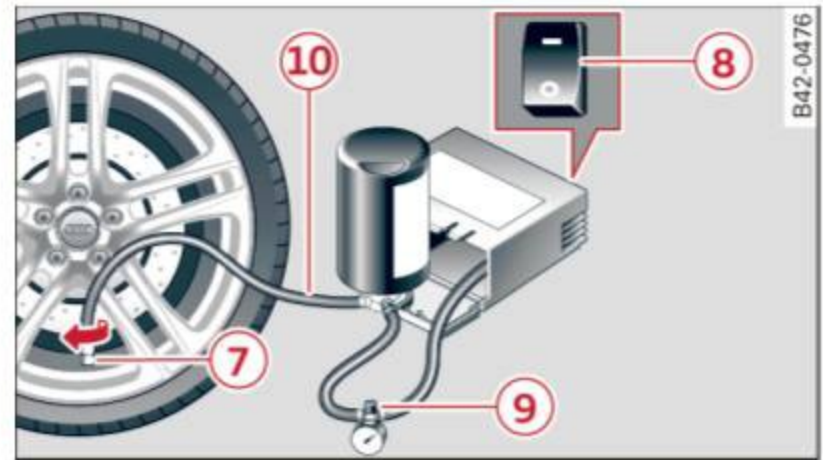

Fig. 156 Connector for the Tire Mobility System

## Assembling Tire Mobility System

- ▶ Open the lid (2) of the electric air pump ⇒ *fig. 155.*
- ▶ Pull the plug (4) and the pressure hose (5) with the gauge out of the housing.
- ▶ Screw the pressure hose (5) of the electric air pump onto the flange (6) of the sealant bottle (1).
- ▶ Push the sealant bottle with the flange down into the recess (3) on the lid of the electric air pump.
- ▶ Remove the dust cap from the valve of the defective tire.
- ▶ Screw the hose (10) onto the valve (7) ⇒ *fig. 156.*
- ▶ Insert the plug (4) ⇒ *fig. 155* into the socket for the cigarette lighter.
- ▶ Switch on the ignition.

## Inflating tire

- ▶ Move the switch (8) ⇒ *fig. 156* on the electric air pump <sup>1)</sup> to position **I**. After 5 minutes, tire pressure must have reached at least 1.8 bar.
- ▶ Switch the electric air pump off - switch in position **0**. If the required tire pressure of at least 1.8 bar has not been reached, follow the instructions in the section *Re-inflating tire.*

## Re-inflating tire

- ▶ Remove the hose from the valve and pull the plug out of the socket.

<sup>1)</sup> The electric air pump should never run for longer than 6 minutes.

- ▶ Drive the vehicle slowly 10 meters backward or forward. This helps to distribute the sealant better.
- ▶ Remove the empty inflation bottle and screw the hose ⑤ ⇒ *fig. 155* from the electric pump directly onto the valve.
- ▶ Insert the plug ④ ⇒ *fig. 155* into the socket for the cigarette lighter.
- ▶ Switch on the ignition.
- ▶ Move the switch ⑧ ⇒ *fig. 156* on the electric air pump <sup>1)</sup> to position **I**. After 5 minutes, tire pressure must have reached at least 1.8 bar.
- ▶ Switch the electric air pump off - switch in position **0**. If the required tire pressure of at least 1.8 bar has not been reached, it is not possible to make a repair with the tire sealant. Seek professional assistance.

### Disassembling Tire Mobility System

- ▶ Remove the hose from the valve and pull the plug out of the socket.
- ▶ Screw the dust cap onto the valve.
- ▶ Place the empty sealant bottle back in the original packaging and clip it in place under the floor so that no tire sealant can run out into the vehicle.
- ▶ Place the electric air pump in the luggage compartment for the time being.
- ▶ Start driving right away so that the sealant is distributed in the tire.

#### WARNING

- Follow the manufacturer's safety instructions on the decal for the air pump and the sealant bottle.
- If a tire pressure of 1.8 bar cannot be achieved after pumping for 5 minutes, the tire is too severely damaged. Do not continue to drive.
- Seek professional assistance if it is not possible to repair the tire with the tire sealant.

#### Tips

- Do not operate the electric air pump for more than 6 minutes without stopping, otherwise it can overheat. When the air pump has cooled down, you can continue to use it.
- If sealant has escaped, allow it to dry, then you can peel it off.

#### Final check

Applies to vehicles: with Tire Mobility System

#### After driving for a short distance, tire pressure must be checked

- ▶ After driving for about 10 minutes, stop and check the tire pressure.
- ▶ If tire pressure is still at least 1.3 bar, inflate the tire to specified pressure (see driver's side B-pillar), drive to the next repair shop and have the tire and the sealant bottle replaced.
- ▶ If tire pressure is less than 1.3 bar, the tire is too severely damaged. Do not continue to drive. Seek professional assistance.

#### WARNING

If tire pressure is less than 1.3 bar after driving for 10 minutes, the tire is too severely damaged. Do not continue to drive. Seek professional assistance.

#### Tips

After a tire repair, have the sealant bottle replaced at a dealership. This restores full functionality to the Tire Mobility System.

<sup>1)</sup> The electric air pump should never run for longer than 6 minutes.

## What should I be aware of when changing a tire?

### General information

The following sections will provide you with important information on how to change a tire using the vehicle tool kit.

However, we recommend that you have a qualified service center change the tire and perform all work associated with changing it.

### Wheels with cap-covered wheel bolts

Applies to vehicles: with cap-covered wheel bolts

*The caps must be removed first from the wheel bolts before the bolts can be unscrewed.*



Fig. 157 Wheel change: removing the wheel bolt caps

#### Removing

- ▶ Push the **plastic clip** provided with the onboard tool kit down over the wheel bolt cap until it engages.
- ▶ Pull on the properly engaged **plastic clip** to extract the cap ⇒ *fig. 157*.

#### Refitting

- ▶ Place the caps over the wheel bolts and push them back in.

The caps are there to protect and keep the wheel bolts clean.

### Decorative wheel covers

Applies to vehicles: with decorative wheel covers

*The decorative wheel covers must be removed first to access the wheel bolts.*



Fig. 158 Wheel change: removing the wheel cover

#### Removing

- ▶ Insert the **hook** provided with the onboard tool kit into the hole on the center hub piece.
- ▶ Pull off the **decorative wheel cover** ⇒ *fig. 158*.

### Loosening and tightening the wheel bolts

*The wheel bolts must be loosened before raising the vehicle.*

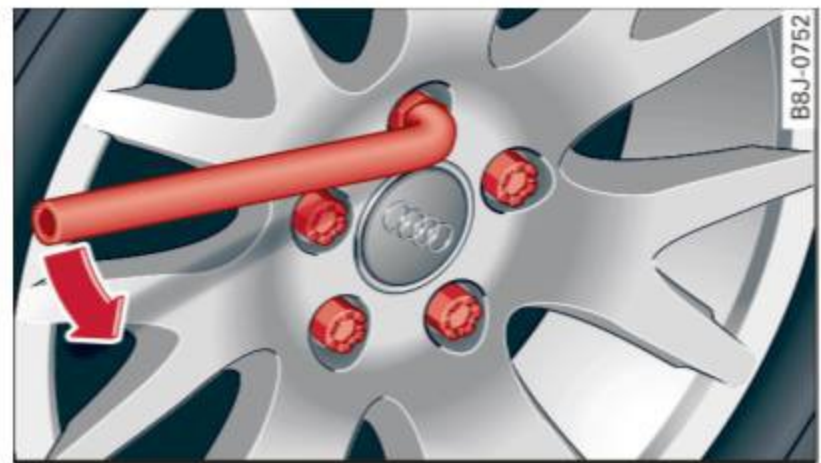

Fig. 159 Wheel change: loosening the wheel bolts

#### Loosening

- ▶ Fit the **wheel bolt wrench** over the wheel bolt and push it down as far as it will go.
- ▶ Close your grip around the *end* of the wrench handle for maximum torque and turn the wheel bolts **counter-clockwise** about *one single* turn in the direction of arrow ⇒ *fig. 159*.

### Tightening

- ▶ Fit the **wheel bolt wrench** over the wheel bolt and push it down as far as it will go.
- ▶ Close your grip around the *end* of the wrench handle for maximum torque and turn each wheel bolt **clockwise** until it sits tight.

#### WARNING

- Using force without control to speed the wheel change up can cause the vehicle to slip off the jack and cause serious personal injuries.
- *Do not* loosen the wheel bolts *more than one turn* before you raise the vehicle with the jack. - Risk of injury!

#### Tips

- Never try and use the hexagonal socket in the handle of the screwdriver to loosen or tighten the wheel bolts.
- If a wheel bolt sits very tight, you may find it easier to loosen by carefully pushing down on the end of the wheel bolt wrench with *one foot only*. As you do, hold on to the car to keep yourself stable and take care not to slip.

### Raising the vehicle

The vehicle must be lifted with the jack first before the wheel can be removed.

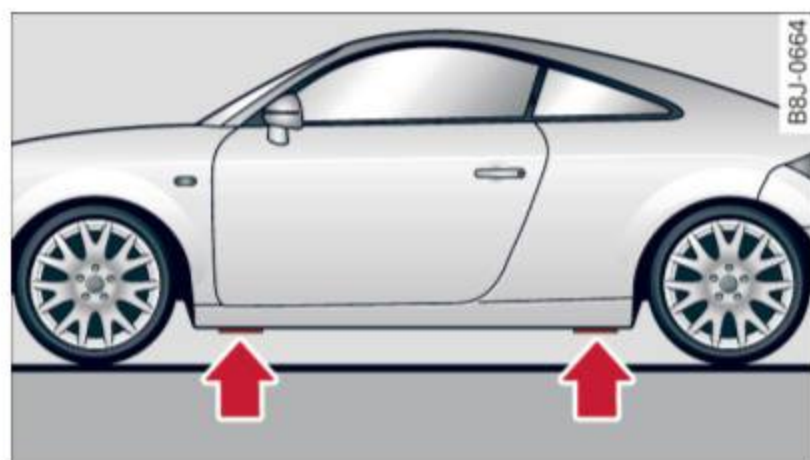

Fig. 160 Sill panels: markings

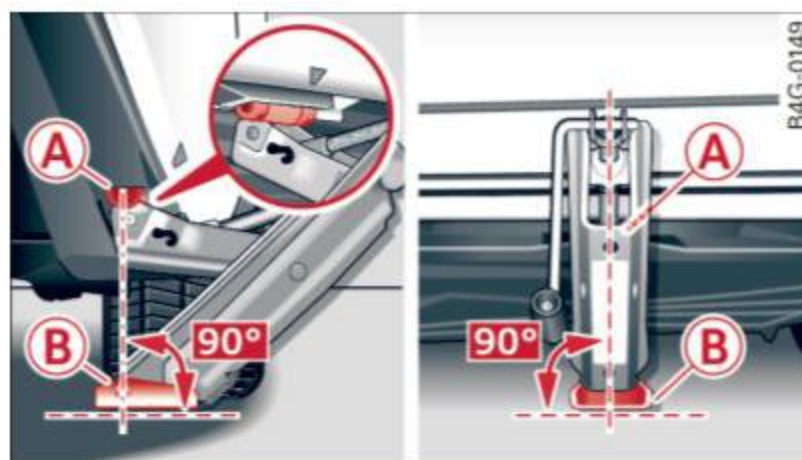







Fig. 161 Sill: positioning the vehicle jack

- ▶ Apply the **parking brake** firmly to prevent your vehicle from rolling unintentionally.
- ▶ Shift into **1st gear** on vehicles with manual transmission, or move the **selector lever to the P position** on vehicles with automatic transmission.
- ▶ Position the jack below the door sill under the **mounting point** that is closest to the wheel to be changed ⇒ *fig. 160*.
- ▶ Extend the **jack** under the lifting point on the door sill until its arm is positioned directly under the lifting point ⇒ .
- ▶ Align the jack so that its arm **A** ⇒ *fig. 161* engages in the designated lifting point in the door sill and the movable base **B** lies flat on the ground. The base **B** must be *vertical* under the lifting point **A**.
- ▶ Wind the jack up further until the flat tire comes off the ground ⇒ .

Position the vehicle jack **only** under the designated lifting points on the sill ⇒ *fig. 160*. There is exactly *one* location for each wheel. The jack must not be positioned at any other location ⇒  ⇒ .

An **unstable surface** under the jack can cause the vehicle to slip off the jack. Always provide a firm base for the jack on the ground. If necessary place a sturdy board or similar support under the jack. On **hard, slippery surfaces** (such as tiles) use a rubber mat or similar to prevent the jack from slipping ⇒ .

#### WARNING

- You or your passengers could be injured while changing a wheel if you do not follow safety precautions:

- Position the vehicle jack only at the designated lifting points and align the jack. Otherwise, the vehicle jack could slip and cause an injury if it does not have sufficient hold on the vehicle.
- A soft or unstable surface under the jack may cause the vehicle to slip off the jack. Always provide a firm base for the jack on the ground. If necessary, use a sturdy board under the jack.
- On hard, slippery surface (such as tiles) use a rubber mat or similar to prevent the jack from slipping.
- To help prevent injury to yourself and your passengers:
  - Do not raise the vehicle until you are sure the jack is securely engaged.
  - Passengers must not remain in the vehicle when it is jacked up.
  - Make sure that passengers wait in a safe place away from the vehicle and well away from the roadway and traffic.
  - Make sure jack position is correct, adjust as necessary and then continue to raise the jack.

### ! Note

A floor jack or the pads on the hoist arms must **not** be positioned at the points shown -arrows-.

### Taking the wheel off

Follow these instructions step-by-step for changing the wheel.



Fig. 162 Wheel change: using the screwdriver handle (with the blade removed) to turn the bolts



Fig. 163 Wheel change: alignment pin inside the top hole

After you have loosened all wheel bolts and raised the vehicle off the ground, perform the following steps to remove and replace the wheel:

### Removing the wheel

- ▶ Use the **hexagonal socket in the screwdriver handle** to completely turn out the top-most wheel bolt and set it aside on a *clean* surface ⇒ *fig. 162*.
- ▶ Screw the threaded end of the **alignment pin** from the tool kit hand-tight into the now vacant bolt hole ⇒ *fig. 163*.
- ▶ Then completely unscrew the other wheel bolts as described above.
- ▶ Take off the wheel leaving the alignment pin in the bolt hole ⇒ !.

### Putting on the wheel

- ▶ Lift the spare wheel and carefully slide it over the alignment pin to guide it in place ⇒ !.
- ▶ Use the hexagonal socket in the screwdriver handle to screw in and tighten all wheel bolts *slightly*.
- ▶ Unscrew the alignment pin and insert and tighten the remaining wheel bolt slightly like the rest.
- ▶ Turn the jack handle counter-clockwise to lower the vehicle until the jack is fully released.
- ▶ Use the wheel bolt wrench to tighten all wheel bolts firmly ⇒ *page 224*. Tighten them *crosswise*, from one bolt to the (approximately) opposite one, to keep the wheel centered.

**! Note**

When removing or installing the wheel, the rim could hit the brake rotor and damage the rotor. Work carefully and have a second person help you.

**i Tips**

Never use the hexagonal socket in the handle of the screwdriver to loosen or tighten the wheel bolts.

- Pull the reversible blade from the screwdriver before you use the hexagonal socket in the handle to turn the wheel bolts.
- When mounting tires with **unidirectional tread design** make sure the tread pattern is pointed the right way ⇒ *page 227*.
- The wheel bolts should be clean and easy to turn. Check for dirt and corrosion on the mating surfaces of both the wheel and the hub. Remove all dirt from these surfaces before remounting the wheel.

**Notes on wheel change**

Please read the information ⇒ *page 207, New tires and replacing tires and wheels*, if you are going to use a spare tire which is different from the tires on your vehicle.

After you change a tire:

- **Check the tire pressure on the spare immediately after mounting.**
- **Have the wheel bolt tightening torque checked with a torque wrench as soon as possible by your authorized Audi dealer or a qualified service station.**
- **With steel and alloy wheel rims, the wheel bolts are correctly tightened at a torque of 90 ft lb (120 Nm).**
- **If you notice while changing a tire that the wheel bolts are corroded and difficult to turn, then they should be replaced before you check the tightening torque.**

- **Replace the flat tire with a new one and have it installed on your vehicle as soon as possible. Remount the wheel cover.**

**Until then, drive with extra care and at reduced speeds.**

**! WARNING**

- If you are going to equip your vehicle with tires or rims which differ from those which were factory installed, then be sure to read the information ⇒ *page 207, New tires and replacing tires and wheels*.
- Always store the tools securely in luggage compartment. Otherwise, in an accident or sudden maneuver they could fly forward, causing injury to passengers in the vehicle.

**Tires with unidirectional tread design**

*Tires with unidirectional tread design must be mounted with their tread pattern pointed the right direction.*

A unidirectional tire can be identified by **arrows on the sidewall**, which point in the direction of the rotation. You must follow the specified direction of rotation. This is necessary in order for these tires to develop their optimum characteristics regarding grip, road noise, wear, and hydroplaning.

## Fuses and bulbs

### Electrical fuses

#### Replacing fuses

Fuses that have blown will have metal strips that have burned through.

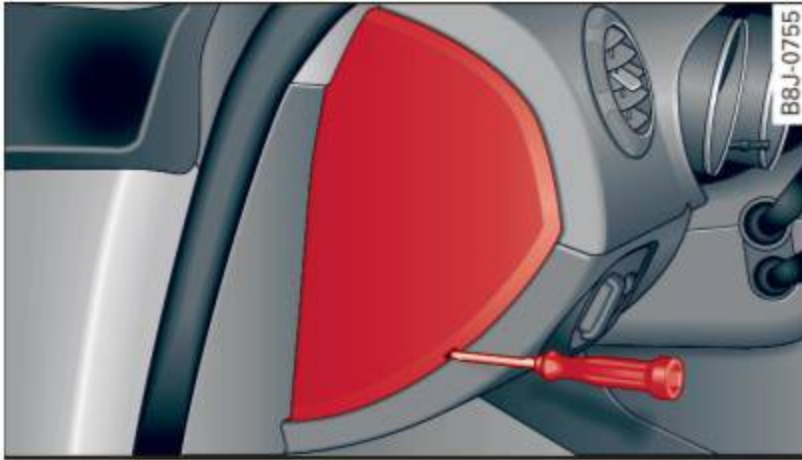

Fig. 164 End face of instrument panel: removing cover plate to access fuses



Fig. 165 Left side of engine compartment: fuse cover

#### Fuse cover on the left end face of the instrument panel

- ▶ Switch off the ignition and the electrical component affected.
- ▶ Carefully pry the fuse cover off the instrument panel using the ignition key or a screwdriver ⇒ *fig. 164*.
- ▶ Check the fuse listing on the next pages to find out which fuse belongs to the component which has failed ⇒ *page 229, Fuse Location, Instrument Panel left*.
- ▶ Remove the blown fuse with the plastic clip provided. The clip is located on the holder in the fuse box.
- ▶ Replace a blown fuse (recognizable by the melted metal strip inside) with a fuse of the *same* amperage.
- ▶ Firmly snap the cover back onto the instrument panel face.

#### Fuse cover in engine compartment

- ▶ Switch the ignition and the affected consumer off.
- ▶ Unlatch the fuse cover, push the two slides forward ⇒ *fig. 165*.
- ▶ Find out which fuse belongs to the equipment which stopped working ⇒ *page 230, Fuse location, left side of engine compartment*.
- ▶ Remove the plastic from its retainer in the fuse box cover (left face end of the instrument panel), place it on the fuse in question and pull it out.
- ▶ If the fuse is burned out (recognizable by melted strips of metal), replace it with a new fuse *of the same* rating.
- ▶ Replace the fuse cover.
- ▶ Push the two slides to the rear ⇒ *fig. 165*. Install the fuse cover carefully to prevent water from entering.

The various electrical circuits are protected by fuses. The fuses are clustered in a centralized unit. The unit is located behind the face panel at the end of the instrument panel.

You are well advised to keep a supply of spare fuses in your vehicle. Fuses with the proper ampere ratings are available at your authorized Audi dealer.

#### WARNING

Do not repair fuses and never replace a blown fuse with one that has a higher amp rating. This can cause damage to the electrical system and a fire.

#### Note

If a new fuse burns out again after shortly have you have installed it, have the electrical system checked by your authorized Audi dealer.

Fuse Location, Instrument Panel left

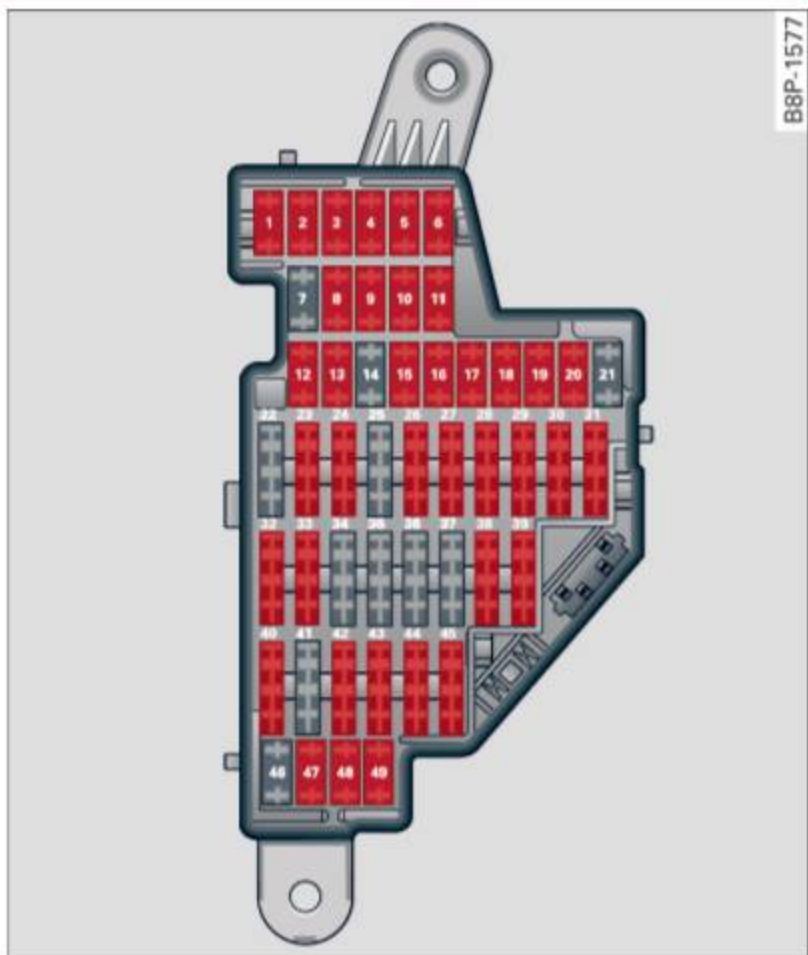

Fig. 166 Fuse carrier behind the instrument panel end face, cover removed

Some of the equipment items listed are optional or only available on certain model configurations.

**Note that the following table is accurate at the time of going to press and is subject to change. In the event of discrepancies, the label on the inside of the cover always takes precedence.**

The power seats are protected by **circuit breakers**, which automatically reset after a few seconds after the overload has been remedied.

No.	Equipment	Amps
1	Engine relay, fuel tank control unit, Airbag Off light, light switch (switch illumination), diagnostic connector	10
2	ABS, ASR, ESC, brake light switch	5
3	AFS headlight (left)	5

No.	Equipment	Amps
4	Oil level sensor (extended maintenance interval) (WIV), tire pressure monitoring system, switch for Electronic Stabilization Control (ESC), AFS headlights (control unit), A/C system (pressure sensor), backup light switch	5
5	Automatic headlight range control, AFS headlight (right) / manual headlight range control, halogen headlights	5/10
6	Control unit for CAN data transfer (gateway), electromechanical steering, automatic transmission shift gate	5
7	Acoustic Park Assist, automatic dipping interior rear view mirror, garage door opener, heatable windshield washer nozzles, washer pump, wind deflector relay (Roadster)	5
8	Haldex clutch/Haldex clutch (TTS)	5/10
9	Control unit Audi magnetic ride	5
10	Airbag control unit	5
11	Mass airflow sensor, crankcase heating	5/10
12	Door control unit (central locking driver/passenger)	10
13	Diagnostic connector	10
14	Rain sensor, automatic transmission shift gate	5
15	Roof light (interior lighting)	5
16	A/C system (control unit)	10
17	Tire pressure monitoring system (control unit)	5
18	Not used	
19	Not used	
20	Not used	
21	Fuel injectors (gasoline engine)	10
22	Wind deflector (Roadster)	30
23	Horn	20

Controls and equipment

Safety first

Vehicle operation

Vehicle care

Do-it-yourself service

Technical data

No.	Equipment	Amps
24	Transmission (control unit)	15
25	Heater rear window Coupe/ heated rear window Roadster	30/20
26	Driver's side power window	30
27	Passenger's side power window	30
28	Not used	
29	Washer pump	15
30	Cigarette lighter	20
31	Starter	40
32	Steering column module	5
33	Instrument cluster	5
34	Radio navigation system, radio	20/15
35	Audio amplifier	30
36	Engine (control unit)	10
37	CAN (Gateway)	5
38	Cigarette lighter	20
39	Not used	
40	Not used	
41	Not used	
42	Not used	
43	Not used	
44	Not used	
45	Not used	
46	Not used	
47	SDARS tuner, cell phone pack- age, TV tuner	5
48	VDA interface	5
49	Not used	

### Fuse location, left side of engine compartment



Fig. 167 Illustration of fuse holder on left side of engine compartment: fuses (without fuse cover)

Some of the equipment items listed are optional or only available on certain model configurations.

**Note that the following table is accurate at the time of going to press and is subject to change.**

No.	Equipment	Amps
<b>Fuse holder (black)</b>		
1	Not used	
2	Not used	
3	Not used	
4	Not used	
5	Anti-theft warning system (sensor), anti-theft warning system (horn)	5
6	Headlamp washer system	30
7	Electric fuel pumps (supply), volume control valve/Interrelais (5-cyl.)	15/10
8	Windshield wipers	30
9	Heated seats (driver and passenger)	25
10	Lumbar support (driver and passenger)	10
11	Not used	
12	Ventilation blower	40
<b>Fuse holder (brown)</b>		
1	Not used	
2	Electric fuel pump (5-cyl.)	30
3	Not used	
4	Not used	
5	Relay coil relay volume control valve (4-cyl.)/O2 sensors (5-cyl.)	5/10
6	O2 sensors	10
7	Positioning valves pre-wired engine harness	10
8	Ignition coils	20
9	Engine (control unit)	25
10	Water pump delayed-off	10

No.	Equipment	Amps
11	Feed (brake pedal)	5
12	Activated charcoal filter/charge pressure control valve	10

## Bulbs

### Replacing light bulbs

*For your safety, we recommend that you have your authorized Audi dealer replace burned out bulbs for you.*

It is becoming increasingly more and more difficult to replace vehicle light bulbs since in many cases, other parts of the car must first be removed before you are able to get to the bulb. This applies especially to the light bulbs in the front of your car which you can only reach through the engine compartment.

Sheet metal and bulb holders can have sharp edges that can cause serious cuts, and parts must be correctly taken apart and then properly put back together to help prevent breakage of parts and long term damage from water that can enter housings that have not been properly resealed.

For your safety, we recommend that you have your authorized Audi dealer replace any bulbs for you, since your dealer has the proper tools, the correct bulbs and the expertise.

### Gas discharge lamps (Xenon lights)\*:

Due to the high electrical voltage, have the bulbs replaced by a qualified technician. Headlights with Xenon light can be identified by the high voltage sticker.

#### WARNING

Contact with high-voltage components of the electrical system and improper replacement of gas discharge (Xenon) headlight bulbs can cause serious personal injury and death.

- Xenon bulbs are pressurized and can explode when being changed.

- Changing Xenon lamps requires the special training, instructions and equipment.
- Only an authorized Audi dealer or other qualified workshop should change the bulbs in gas discharge lamps.

#### WARNING

There are parts with sharp edges on the openings and on the bulb holders that can cause serious cuts.

- If you are uncertain about what to do, have the work performed by an authorized Audi dealer or other qualified workshop. Serious personal injury may result from improperly performed work.

#### Tips

- If you must replace the light bulbs yourself, always remember that the engine compartment of any vehicle is a hazardous area to work in. Always read and heed all WARNINGS ⇒ *page 174, Engine compartment* ⇒ .
- It is best to ask your authorized Audi dealer whenever you need to change a bulb.

## Emergency situations

### General

This chapter is intended for trained emergency crews and working personnel who have the necessary tools and equipment to perform these operations.

### Starting by pushing or towing

#### Note

Vehicles with an automatic transmission cannot be started by pushing or towing.

### Starting with jumper cables

*If necessary, the engine can be started by connecting it to the battery of another vehicle.*

If the engine should fail to start because of a discharged or weak battery, the battery can be connected to the battery of *another* vehicle, using a **pair of jumper cables** to start the engine.

#### Jumper cables

Use *only* jumper cables of sufficiently large **cross section** to safely carry the starter current. Refer to the manufacturer's specifications.

Use only jumper cables which have *insulated* terminal clamps and are properly marked for distinction:

**plus (+) cable** in most cases colored **red**

**minus (-) cable** in most cases colored **black**.

#### WARNING

Batteries contain electricity, acid, and gas. Any of these can cause very serious or fatal injury. Follow the instructions below for safe handling of your vehicle's battery.

- Always shield your eyes and avoid leaning over the battery whenever possible.

- A discharged battery can already freeze at temperatures just below 32 °F (0 °C). Before connecting a jumper cable, the frozen battery must be thawed completely, otherwise it could explode.
- Do not allow battery acid to contact eyes or skin. Flush any contacted area with water immediately.
- Improper use of a booster battery to start a vehicle may cause an explosion.
- Vehicle batteries generate explosive gases. Keep sparks, flame and lighted cigarettes away from batteries.
- Do not try to jump start any vehicle with a low acid level in the battery.
- The voltage of the booster battery must also have a 12-Volt rating. The capacity (Ah) of the booster battery should not be lower than that of the discharged battery. Use of batteries of different voltage or substantially different "Ah" rating may cause an explosion and personal injury.
- Never charge a frozen battery. Gas trapped in the ice may cause an explosion.
- Never charge or use a battery that has been frozen. The battery case may have been weakened.
- Use of batteries of different voltage or substantially different capacity (Ah) rating may cause an explosion and injury. The capacity (Ah) of the booster battery should not be lower than that of the discharged battery.
- Before you check anything in the engine compartment, always read and heed all WARNINGS ⇒ *page 174, Engine compartment*.

#### Note

- Applying a higher voltage booster battery will cause expensive damage to sensitive electronic components, such as control units, relays, radio, etc.
- There must be no electrical contact between the vehicles as otherwise current could already start to flow as soon as the positive (+) terminals are connected.

**i Tips**

The discharged battery must be properly connected to the vehicle's electrical system.

**Use of jumper cables**

Make sure to connect the jumper cable clamps in exactly the order described below!

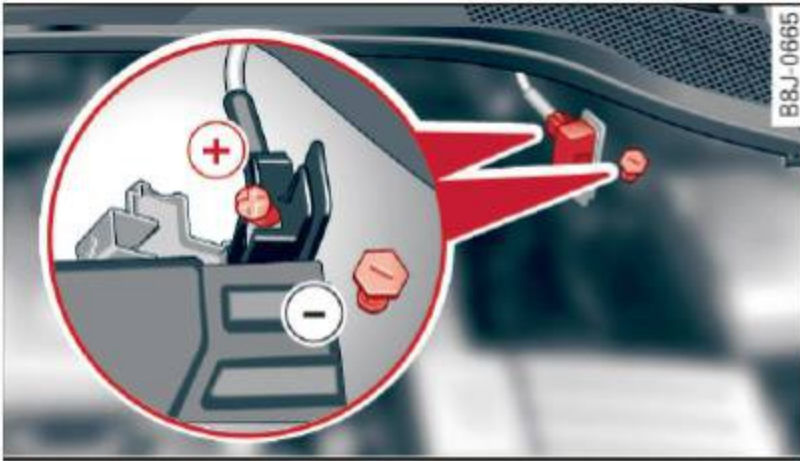

Fig. 168 Engine compartment: Connectors for jumper cables and charger

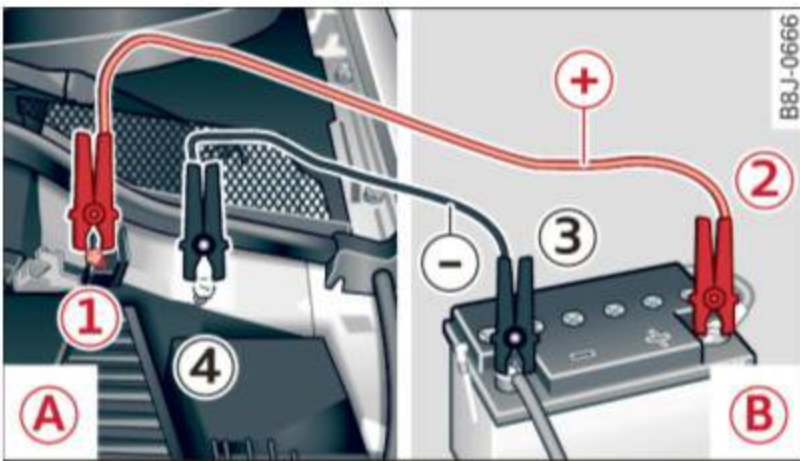

Fig. 169 Jump starting with the battery of another vehicle: (A) discharged vehicle battery, (B) booster battery

The procedure described below for connecting jumper cables is intended to provide a jump start for your vehicle.

**Preparatory measures**

1. Do not jump start a frozen battery! Replace such a battery!
2. Otherwise apply the hand brake and shift into idle gear if your vehicle has manual transmission, and put the selector lever into P position if your vehicle has automatic transmission.
3. For both vehicles switch off all consumers and the ignition.

**Connecting/disconnecting the jumper cable.**

4. Connect one end of the red jumper cable on the **jump start bolt** (1) ⇒ fig. 169 (Bolts under red cover = "positive") of the vehicle to be started (A).
5. Connect the other end of the red jumper cable to the positive terminal (2) of the booster battery (B).
6. Connect one end of the black jumper cable to the negative terminal (3) of the booster battery (B).
7. Connect the other end of the black jumper cable to the negative terminal (bolt head) (4) in the external starting point (A) of your vehicle.
8. Route the jumper cables so that they cannot catch in any rotating parts in the engine compartment.

**Starting the engine**

9. Start the engine of the vehicle providing assistance and allow it to run at idle.
10. Now start the engine of the vehicle with the discharged battery, wait for two to three minutes until the engine "runs" smoothly.
11. If the engine does not start: Stop trying after 10 seconds and then try again after about 30 seconds.
12. In the vehicle that has received start assistance, turn on the heater blower and the rear window heating to eliminate any voltage peaks when disconnecting. Driving lights must be switched off!
13. Disconnect the cable while the engine is running exactly in *reverse* order to that described in ⇒ page 233, *Connecting/disconnecting the jumper cable*.. When doing so, make sure that the cable cannot contact rotating engine parts.
14. Close the cover on the positive terminal.

The battery is vented to the outside to prevent gases from entering the vehicle interior. Make sure that the jumper clamps are well connected with their *metal parts in full contact* with the battery terminals.

 **WARNING**

To avoid serious personal injury and damage to the vehicle, heed all warnings and instructions of the jumper cable manufacturer. If in doubt, call for road service.

- Jumper cables must be long enough so that the vehicles do not touch.
- When connecting jumper cables, make sure that they cannot get caught in any moving parts in the engine compartment.
- Before you check anything in the engine compartment, always read and heed all **WARNINGS** ⇒ *page 174, Engine compartment*.

 **Note**

Improper hook-up of jumper cables can ruin the generator.

- Always connect POSITIVE (+) to POSITIVE (+), and NEGATIVE (-) to NEGATIVE (-) ground post of the battery manager control unit.
- Check that all screw plugs on the battery cells are screwed in firmly. If not, tighten plugs prior to connecting clamp on negative battery terminal.
- Please note that the procedure for connecting a jumper cable as described above applies specifically to the case of your vehicle being jump started. When you are giving a jump start to another vehicle, do *not* connect the negative (-) cable to the negative (-) terminal on the discharged battery . Instead, securely connect the negative (-) cable to either a solid metal component that is firmly bolted to the engine block or to the engine block itself. If the battery that is being charged does not vent to the outside, escaping battery gas could ignite and explode!

## Emergency towing with commercial tow truck

### General hints

*Your Audi requires special handling for towing.*

The following information is to be used by commercial tow truck operators who know how to operate their equipment safely.

- **Never tow your Audi, towing will cause damage to the engine and transmission.**
- **Never wrap the safety chains or winch cables around the brake lines.**
- **To prevent unnecessary damage, your Audi must be transported with a car carrier (flatbed truck).**
- **To load the vehicle on to the flat bed, use the towing loop found in the vehicle tools and attach to the front or rear anchorage** ⇒ *page 235* and ⇒ *page 236*.

 **WARNING**

A vehicle being towed is not safe for passengers. Never allow anyone to ride in a vehicle being towed, for any reason.

### Front towing loop (Version A)

Do not install the front towing loop until it is needed.



Fig. 170 Front bumper: removing the grill

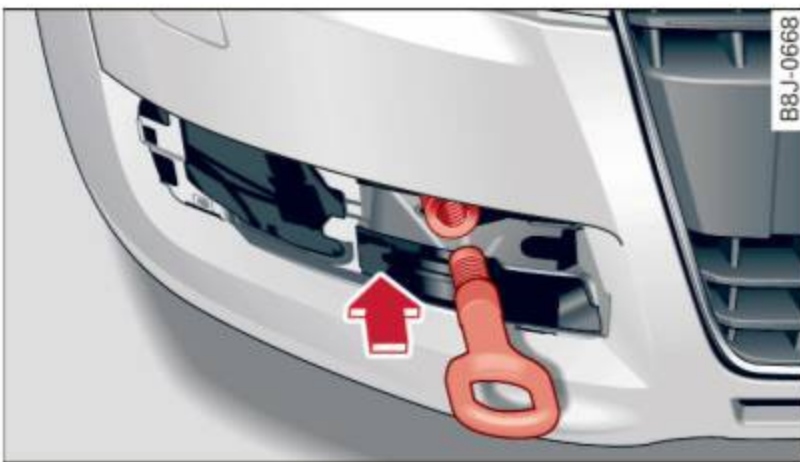

Fig. 171 Front bumper: screwing in the towing loop

The towing loop fits into the threaded hole located on the right side of the front bumper behind the grill.

- ▶ Remove the screwdriver and towing loop from the vehicle toolkit ⇒ *page 220*.
- ▶ Insert the screwdriver into the slot as shown and press toward the center of the vehicle ⇒ *fig. 170*. At the same time, pull the grill forward and out.
- ▶ Screw the towing loop tightly into the threaded hole as far as it will go ⇒ *fig. 171*.

When it is no longer needed, unscrew the towline eye and put it back into the on-board toolkit. Make sure to have the towline eye stored in the vehicle at all times.

When installing the grill for the air duct, be sure that the tabs on the grill are first inserted into their guides on the vehicle. Then push the grill into position.

### ! WARNING

If the towing loop is not screwed in as far as it will go, the thread can pull out when the vehicle is towed - potential risk of an accident.

### Front towing loop (Version B)

Do not install the front towing loop until it is needed.



Fig. 172 Right front section: removing the air intake grille



Fig. 173 Right front section with plastic cover

A threaded opening with **left-hand threads** is located at the front right of the bumper behind the air intake grille. The towing loop is installed in this opening.

- ▶ Remove the screwdriver and the towing loop from the vehicle tool kit ⇒ *page 220*.
- ▶ Reach through the air intake grille, grip the horizontal fins and pull it forward to remove.
- ▶ Use the screwdriver to pry the plastic cover off ⇒ *fig. 173*.
- ▶ Install the towing loop in the threaded opening and tighten it until it stops ⇒ *page 235, fig. 171*.

Remove the towing loop when you are done using it and place it back in the vehicle tool kit. Always keep the towing loop in the vehicle.

When installing the air intake grille, insert the tabs on the grille in the mounts on the vehicle first. Then press the grille in to secure it.

### WARNING

If the towing loop is not tightened until it stops when installing, the threads may be pulled out when towing the vehicle and that could cause an accident.

### Rear towing loop

Do not install the rear towing loop until it is needed.

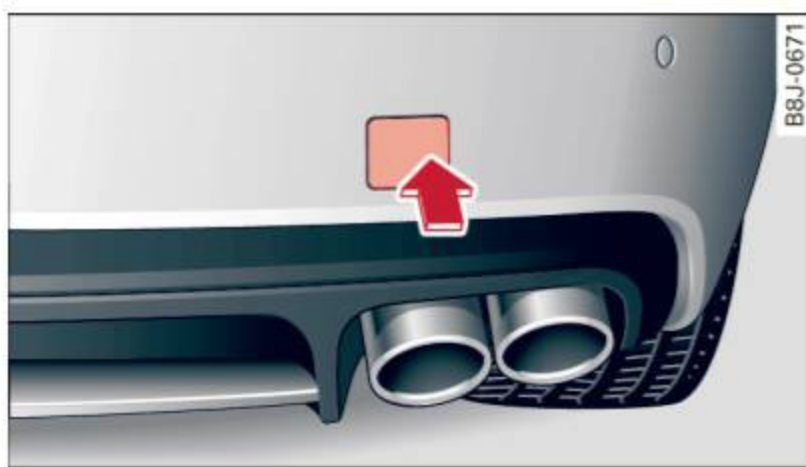

Fig. 174 Right rear section



Fig. 175 Rear bumper: screwing in the towing loop

On the right side under the rear bumper there is a threaded hole for the towing loop. The threaded hole is protected by a cover.

- ▶ Remove the towing loop from the vehicle toolkit ⇒ *page 220*.
- ▶ Press the right side of the cover inward forcefully to remove it from the bumper. ⇒ *fig. 174*.

- ▶ Screw the towing loop tightly into the threaded hole as far as it will go.

When it is no longer needed, unscrew the towing loop and put it back into the vehicle toolkit. Be sure to have the towing loop stored in the vehicle at all times.

### WARNING

If the towing loop is not screwed in as far as it will go, the thread can pull out when the vehicle is towed - potential risk of an accident.

### Loading the vehicle onto a flatbed truck



Fig. 176 Vehicle on flatbed truck

### Front hook up

- ▶ Align the vehicle with the centerline of the car carrier ramp.
- ▶ Attach the winch hook to the front towline eye previously installed.

### Rear hook up

- ▶ Align the vehicle with the centerline of the car carrier ramp.
- ▶ Attach the winch hook to the rear towline eye previously installed.

### Tips

Check carefully to make sure the hook-up is secure before moving the car up the flatbed truck ramp.

## Lifting vehicle

### Lifting with workshop hoist and with floor jack

The vehicle may only be lifted at the lifting points illustrated.



Fig. 177 Rear lifting point (right side)

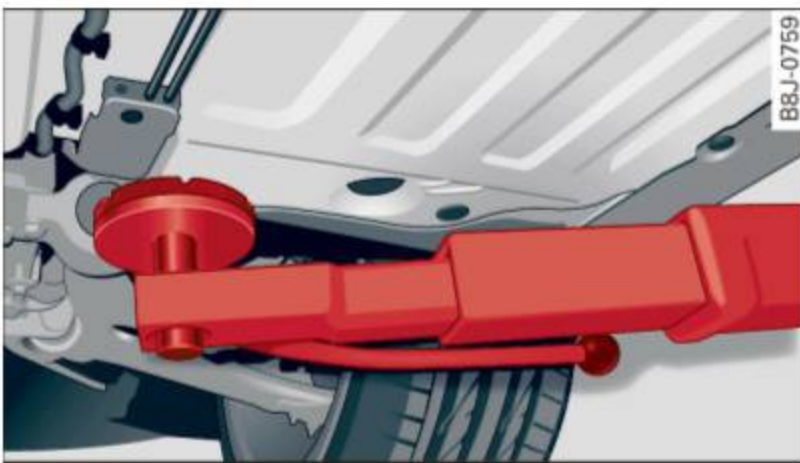

Fig. 178 Front lifting point (right side)

- ▶ Read and heed WARNING ⇒ ⚠.
- ▶ Locate lifting points ⇒ fig. 177 ⇒ fig. 178.
- ▶ Adjust lifting arms of workshop hoist or floor jack to match vehicle lifting points.
- ▶ Insert a rubber pad between the floor jack/workshop hoist and the lifting points.

If you must lift your vehicle with a floor jack to work underneath, be sure the vehicle is safely supported on stands intended for this purpose.

#### Front lifting point

The lifting point is located on the floor pan reinforcement about at the same level as the jack mounting point ⇒ fig. 178. **Do not lift the vehicle at the vertical sill reinforcement.**

#### Rear lifting point

The lifting point is located on the vertical reinforcement of the lower sill for the onboard jack ⇒ fig. 177.

### Lifting with vehicle jack

Refer to ⇒ page 225.

#### ⚠ WARNING

- To reduce the risk of serious injury and vehicle damage.
- Always lift the vehicle only at the special workshop hoist and floor jack lift points illustrated ⇒ fig. 177 and ⇒ fig. 178.
- Failure to lift the vehicle at these points could cause the vehicle to tilt or fall from a lift if there is a change in vehicle weight distribution and balance. This might happen, for example, when heavy components such as the engine block or transmission are removed.
- When removing heavy components like these, anchor vehicle to hoist or add corresponding weights to maintain the center of gravity. Otherwise, the vehicle might tilt or slip off the hoist, causing serious personal injury.

#### ! Note

- Be aware of the following points before lifting the vehicle:
  - **The vehicle should never be lifted or jacked up from underneath the engine oil pan, the transmission housing, the front or rear axle or the body side members. This could lead to serious damage.**
  - To avoid damage to the underbody or chassis frame, a rubber pad must be inserted between the floor jack and the lift points.
  - Before driving over a workshop hoist, check that the vehicle weight does not exceed the permissible lifting capacity of the hoist.
  - Before driving over a workshop hoist, ensure that there is sufficient clearance between the hoist and low parts of the vehicle.

## General information

### Explanation of technical data

Some of the technical data listed in this manual require further explanation.

The technical data for your vehicle are listed in the charts starting on ⇒ page 240. This chapter provides general information, notes and restrictions which apply to these data.

### Vehicle identification

The key data are given on the vehicle identification number (VIN) plate and the vehicle data sticker.



Fig. 179 Vehicle Identification Number (VIN) plate: location on driver's side dash panel

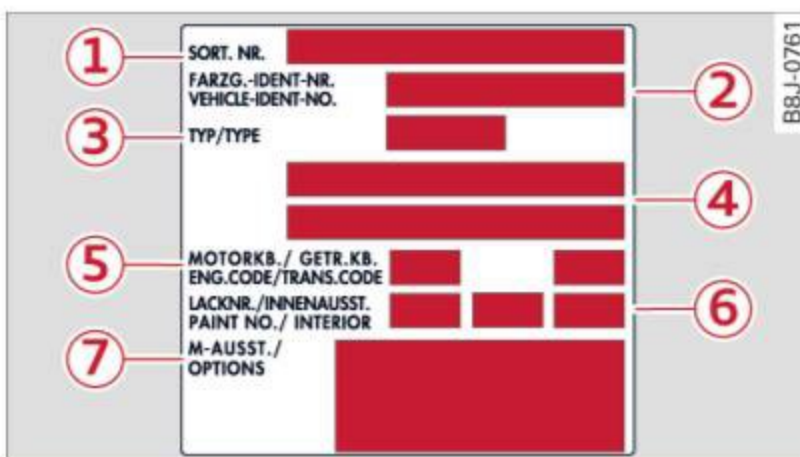

Fig. 180 The vehicle identification label – inside the luggage compartment

#### The Vehicle Identification Number (VIN)

is located on the driver's side so that it is visible from the outside through the windshield – see ⇒ fig. 179. You can also display the Vehicle Identification Number of your vehicle in the Driver Information display ⇒ page 24.

#### The vehicle identification label

is located in the luggage compartment in the spare wheel well.

The label ⇒ fig. 180 shows the following vehicle data:

- ① Production control No.
- ② Vehicle identification No.
- ③ Type code number
- ④ Type designation/engine output in Kilowatts
- ⑤ Engine and transmission code letter
- ⑥ Paint No./Interior
- ⑦ Optional equipment No.'s

Vehicle data 2 to 7 are also found in your Warranty & Maintenance booklet.

#### The safety compliance sticker

is your assurance that your new vehicle complies with all applicable Federal Motor Vehicle Safety Standards which were in effect at the time the vehicle was manufactured. You can find this sticker on the left door jamb. It shows the month and year of production and the vehicle identification number of your vehicle (perforation) as well as the Gross Vehicle Weight Rating (GVWR) and the Gross Axle Weight Rating (GAWR).

#### The high voltage warning label

is located on the lock carrier.

The spark ignition system complies with the Canadian standard ICES-002.

## Weights

### Gross Vehicle Weight Rating

The Gross Vehicle Weight Rating (GVWR), and the Gross Axle Weight Rating (GAWR) for front and rear are listed on a sticker on the left door jamb.

The Gross Vehicle Weight Rating includes the weight of the basic vehicle plus full fuel tank, oil and coolant, plus maximum load, which includes passenger weight (150 lbs/68 kg per ►

designated seating position) and luggage weight.

### Gross Axle Weight Rating

The Gross Axle Weight Rating is the maximum load that can be applied at each axle of the vehicle ⇒ .

### Vehicle capacity weight

The vehicle capacity weight (max. load) is listed either on the driver's side B-pillar or inside the fuel filler flap.

### Roof weight

The maximum permissible roof weight is **165 lb (75 kg)**. The roof weight is made up of the weight of the roof rack system and the weight of the object being transported ⇒ *page 61, Loading the roof rack.*

#### WARNING

- The actual Gross Axle Weight Rating at the front and rear axles should not exceed the permissible weights, and their combination must not exceed the Gross Vehicle Weight Rating.
- Exceeding permissible weight ratings can result in vehicle damage, accidents and personal injury.

#### Note

- The vehicle capacity weight figures apply when the load is distributed evenly in the vehicle (passengers and luggage). When transporting a heavy load in the luggage compartment, carry the load as near to the rear axle as possible so that the vehicle's handling is not impaired.
- Do not exceed the maximum permissible axle loads or the maximum gross vehicle weight. Always remember that the vehicle's handling will be affected by the extra load. Therefore, adjust your speed accordingly.
- Always observe local regulations.

## Dimensions

The specifications refer to the basic model. Differences may occur depending on the model type and options ordered, for example, tire sizes.

#### Note

When driving up steep ramps, on rough roads, over curbs, etc. it is important to remember that some parts of your vehicle, such as spoilers or exhaust system components, may be close to the ground. Be careful not to damage them.

## Data

### 211 hp, 2.0 liter 4-cyl. turbo engine (TT Coupe)

Applies to vehicles: with 2.0 liter 4-cyl. engine

#### Engine data

Maximum output SAE net	hp @ rpm	211 @ 4300 - 6000
Maximum torque SAE net	lb-ft @ rpm	259 @ 1600 - 4200
No. of cylinders		4
Displacement	CID (cm <sup>3</sup> )	121 (1984)
Stroke	in (mm)	3.65 (92.8)
Bore	in (mm)	3.25 (82.5)
Compression ratio		9.6 : 1
Fuel	<b>Premium unleaded (91 AKI)</b> Recommended for maximum engine performance. Further details ⇒ <i>page 176, Gasoline</i>	

#### Dimensions (approx.)

Length (with license plate bracket)	in (mm)	165.3 (4198)
Width (across mirrors)	in (mm)	76.9 (1952)
Height (unloaded)	in (mm)	53 (1345)
Turning circle diameter (curb to curb)	ft. (m)	35,96 (10.96)

#### Capacities (approx.)

<b>Fuel tank</b>		
- Total capacity	gal/liters	14.5 / 55.0
- Reserve (of total capacity)	gal/liters	1.9 / 7.0
<b>Windshield and headlight* washer fluid container</b>	quarts/liters	4.3 / 4.0
<b>Engine oil with filter change</b>	quarts/liters	4.8 / 4.5

## 265 hp, 2.0 liter 4-cyl. turbo engine (TTS Coupe)

Applies to vehicles: with 2.0 liter 4-cyl. engine

### Engine data

Maximum output SAE net	hp @ rpm	265 @ 6000
Maximum torque SAE net	lb-ft @ rpm	258 @ 2500 - 5000
No. of cylinders		4
Displacement	CID (cm <sup>3</sup> )	121 (1984)
Stroke	in (mm)	3.65 (92.8)
Bore	in (mm)	3.25 (82.5)
Compression ratio		9.8 : 1
Fuel	<b>Premium unleaded (91 AKI)</b> Recommended for maximum engine performance. Further details ⇒ <i>page 176, Gasoline</i>	

### Dimensions (approx.)

Length (with license plate bracket)	in (mm)	165.3 (4198)
Width (across mirrors)	in (mm)	76.9 (1952)
Height (unloaded)	in (mm)	53 (1345)
Turning circle diameter (curb to curb)	ft. (m)	35,96 (10.96)

### Capacities (approx.)

<b>Fuel tank</b>		
- Total capacity	gal/liters	14.5 / 55.0
- Reserve (of total capacity)	gal/liters	1.9 / 7.0
<b>Windshield and headlight* washer fluid container</b>	quarts/liters	4.3 / 4.0
<b>Engine oil with filter change</b>	quarts/liters	4.8 / 4.5

## 360 hp, 2.5 liter 5-cyl. turbo engine (TT RS Coupe)

Applies to vehicles: with 2.5 liter 5-cyl. engine

### Engine data

Maximum output SAE net	hp @ rpm	360 @ 5500 - 6700
Maximum torque SAE net	lb-ft @ rpm	343 @ 1650 - 5400
No. of cylinders		5
Displacement	CID (cm <sup>3</sup> )	151 (2480)
Stroke	in (mm)	3.65 (92.8)
Bore	in (mm)	3.25 (82.5)
Compression ratio		10 : 1
Fuel	<b>Premium unleaded (91 AKI)</b> Recommended for maximum engine performance. Further details ⇒ <i>page 176, Gasoline</i>	

### Dimensions (approx.)

Length (with license plate bracket)	in (mm)	165.3 (4198)
Width (across mirrors)	in (mm)	76.9 (1952)
Height (unloaded)	in (mm)	53 (1345)
Turning circle diameter (curb to curb)	ft. (m)	35,96 (10.96)

### Capacities (approx.)

<b>Fuel tank</b>		
- Total capacity	gal/liters	14.5 / 55.0
- Reserve (of total capacity)	gal/liters	1.9 / 7.0
<b>Windshield and headlight* washer fluid container</b>	quarts/liters	4.3 / 4.0
<b>Engine oil with filter change</b>	quarts/liters	6.9 / 6.5

## Consumer Information

### Warranty coverages

Your Audi is covered by the following warranties:

- *New Vehicle Limited Warranty*
- *Limited Warranty Against Corrosion Performance*
- *Emissions Control System Warranty*
- *Emissions Performance Warranty*
- *California Emissions Control Warranty (USA vehicles only)*
- *California Emissions Performance Warranty (USA vehicles only)*

Detailed information regarding your warranties can be found in your **Warranty & Maintenance booklet**.

### Operating your vehicle outside the U.S.A. or Canada

Government regulations in the United States and Canada require that automobiles meet specific emission regulations and safety standards. Therefore, vehicles built for the U.S.A. and Canada differ from vehicles sold in other countries.

If you plan to take your vehicle outside the continental limits of the United States or Canada, there is the possibility that:

- unleaded fuels for vehicles with catalytic converter may not be available;
- fuel may have a considerably lower octane rating. Improper fuel may cause engine damage;
- service may be inadequate due to lack of proper service facilities, tools or testing equipment;
- replacement parts may not be readily available.
- Navigation systems for vehicles built for the U.S.A. and Canada will not necessarily work in Europe, and may not work in other countries outside of North America.

#### Note

Audi cannot be responsible for mechanical damage that could result from inadequate fuel, service or parts availability.

### Audi Service Repair Manuals and Literature

Audi Official Factory Service Manuals and Literature are published as soon as possible after model introduction. Service Manuals and literature are available to order from the Audi Technical Literature Ordering Center at:

[www.audi.techliterature.com](http://www.audi.techliterature.com)

### Maintenance

#### General

Your vehicle has been designed to help keep maintenance requirements to a minimum. However, a certain amount of regular maintenance is still necessary to assure your vehicle's safety, economy and reliability. For detailed vehicle maintenance consult your Warranty & Maintenance booklet.

**Under difficult operating conditions**, for example at extremely low outside temperatures, in very dusty regions, etc., some service work should be performed between the intervals specified. This applies particularly to:

- oil changes, and
- cleaning or replacing the air filter.

#### For the sake of the environment

By regularly maintaining your vehicle, you help make sure that emission standards are maintained, thus minimizing adverse effects on the environment.

#### Important considerations for you and your vehicle

The increasing use of electronics, sophisticated fuel injection and emission control systems, and the generally increasing technical complexity of today's automobiles, have

steadily reduced the scope of maintenance and repairs which can be carried out by vehicle owners. **Also, safety and environmental** concerns place very strict limits on the nature of repairs and adjustments to engine and transmission parts which an owner can perform.

Maintenance, adjustments and repairs usually require special tools, testing devices and other equipment available to specially trained workshop personnel in order to assure proper performance, reliability and safety of the vehicle and its many systems.

Improper maintenance, adjustments and repairs can impair the operation and reliability of your vehicle and even void your vehicle warranty. Therefore, proof of servicing in accordance with the maintenance schedule may be a condition for upholding a possible warranty claim made within the warranty period.

Above all, operational safety can be adversely affected, creating unnecessary risks for you and your passengers.

If in doubt about any servicing, have it done by your authorized Audi dealer or any other properly equipped and qualified workshop. We strongly urge you to give your authorized Audi dealer the opportunity to perform all scheduled maintenance and necessary repairs. Your dealer has the facilities, original parts and trained specialists to keep your vehicle running properly.

### Performing limited maintenance yourself

The following pages describe a limited number of procedures which can be performed on your vehicle with ordinary tools, should the need arise and trained personnel be unavailable. Before performing any of these procedures, always thoroughly read all of the applicable text and carefully follow the instructions given. Always rigorously observe the **WARNINGS** provided.

**Before you check anything in the engine compartment, always read and heed all WARNINGS** ⇨  **and** ⇨  *in Working in the engine compartment on page 180.*

### **WARNING**

- Serious personal injury may occur as a result of improperly performed maintenance, adjustments or repairs.
- Always be extremely careful when working on the vehicle. Always follow commonly accepted safety practices and general common sense. Never risk personal injury.
- Do not attempt any of the maintenance, checks or repairs described on the following pages if you are not fully familiar with these or other procedures with respect to the vehicle, or are uncertain how to proceed.
- Do not do any work without the proper tools and equipment. Have the necessary work done by your authorized Audi dealer or another properly equipped and qualified workshop.
- The engine compartment of any motor vehicle is a potentially hazardous area. Never reach into the area around or touch the radiator fan. It is temperature controlled and can switch on suddenly - even when the engine is off and the ignition key has been removed. The radiator fan switches on automatically when the coolant reaches a certain temperature and will continue to run until the coolant temperature drops.
- Always remove the ignition key before anyone gets under the vehicle.
- Always support your vehicle with safety stands if it is necessary to work underneath the vehicle. The jack supplied with the vehicle is not adequate for this purpose and could collapse causing serious personal injury.
- If you must work underneath the vehicle with the wheels on the ground, always make sure the vehicle is on level ground, that the wheels are always securely blocked and that the engine cannot be started.
- Always make sure the transmission selector lever (automatic transmission) is

in "P" (Park position) (automatic transmission) or Neutral (manual transmission) and the hand brake is firmly applied.



### For the sake of the environment

- Changing the engine settings will adversely affect emission levels. This is detrimental to the environment and increases fuel consumption.
- Always observe environmental regulations when disposing of old engine oil, used brake fluid, dirty engine coolant, spent batteries or worn out tires.
- Undeployed airbag modules and pretensioners might be classified as Perchlorate Material -special handling may apply, see [www.dtsc.ca.gov/hazardous-waste/perchlorate](http://www.dtsc.ca.gov/hazardous-waste/perchlorate). When the vehicle or parts of the restraint system including airbag modules safety belts with pretensioners are scrapped, all applicable laws and regulations must be observed. Your authorized Audi dealer is familiar with these requirements and we recommend that you have your dealer perform this service for you.

## Additional accessories, modifications and parts replacement

### Additional accessories and parts replacement

*Always consult an authorized Audi dealer before purchasing accessories.*

Your vehicle incorporates the latest safety design features ensuring a high standard of active and passive safety.

This safety could be compromised by non-approved changes to the vehicle. For this reason, if parts have to be replaced, please observe the following points when installing additional accessories:

Approved Audi accessories and genuine Audi parts are available from authorized Audi dealers.

These dealers also have the necessary facilities, tools and trained specialists to install the parts and accessories properly.



### WARNING

- Using the wrong spare parts or using non-approved accessories can cause damage to the vehicle and serious personal injury.
- Use only accessories expressly approved by Audi and genuine Audi spare parts
  - These parts and accessories have been specially designed to be used on your vehicle.
  - Never install accessories such as telephone cradles or beverage holders on airbag covers or within the airbag deployment zones. Doing so will increase the risk of injury if airbags are triggered in an accident!
  - Before you check anything in the engine compartment, always read and heed all WARNINGS ⇨ *page 174*.



### Note

- If items other than genuine Audi spare parts, add-on equipment and accessory items are used or if repair work is not performed according to specified methods, this can result in severe damage to your vehicle's engine and body (such as corrosion) and adversely affect your vehicle's warranty.
- The innovative aluminium concept of your Audi TT means that all servicing, repairs or other work on the vehicle body must be carried out exclusively by an Audi workshop.
- If emergency repairs must be performed elsewhere, have the vehicle examined by an authorized Audi dealership as soon as possible.
- The manufacturer cannot be held liable for damage which occurs due to failure to comply with these stipulations.

## Technical Modifications

*Our guidelines must be complied with when technical modifications are made.*

Always consult an authorized Audi dealer **before** starting work on any modifications.

This will help ensure that vehicle function, performance and safety are not impaired

⇒ ⚠.

Attempting to work on electronic components and the software used with them can cause malfunctions. Because of the way electronic components are interconnected with each other, such malfunctions can also have an adverse affect on other systems that are not directly involved. This means that you risk both a substantial reduction in the operational safety of your vehicle and an increased wear of vehicle parts ⇒ ⚠.

Authorized Audi dealers will perform this work in a professional and competent manner or, in special cases, refer you to a professional company that specializes in such modifications.

### WARNING

Improper repairs and modifications can change the way vehicle systems work and cause damage to the vehicle and serious personal injury.

### Note

If emergency repairs must be performed elsewhere, have the vehicle examined by an authorized Audi dealership as soon as possible.

## Declaration of Compliance, Telecommunication or Electronic Systems

*Radio Frequency Devices and Radiocommunication Equipment User Manual Notice.*

The manufacturer is not responsible for any radio or TV interference caused by unauthorized modifications to this equipment.

## Devices

The following devices each comply with FCC Part 15.19, FCC Part 15.21 and RSS-Gen Issue 1:

- Cell phone package
- Electronic immobilizer
- HomeLink® universal remote control
- Remote control key

### FCC Part 15.19

This device complies with part 15 of the FCC Rules. Operation is subject to the following two conditions:

- (1) This device may not cause harmful interference, and
- (2) this device must accept any interference received, including interference that may cause undesired operation.

### FCC Part 15.21

CAUTION:

Changes or modifications not expressly approved by the party responsible for compliance could void the user's authority to operate the equipment.

### RSS-Gen Issue 1

Operation is subject to the following two conditions:

- (1) this device may not cause interference, and
- (2) this device must accept any interference, including interference that may cause undesired operation of the device.

- A**
- A/C operation ..... 69
  - Accessories ..... 245
  - Acoustic park assist ..... 78
  - Adaptive light ..... 43
    - defective ..... 20
  - Adding
    - Engine coolant ..... 188
    - Engine oil ..... 185
    - Windshield washer fluid ..... 194
  - Additional accessories ..... 245
  - Additives
    - Engine oil ..... 185
  - Adjustable steering column ..... 71
  - Adjusting front seats ..... 54
  - Adjusting steering column ..... 71
  - Adjusting the seats ..... 55
  - Advanced Airbag System
    - Children ..... 131
    - Components ..... 115
    - Front airbags ..... 113
    - How the components work together .. 116
    - Monitoring ..... 119
    - Weight-sensing mat ..... 131
  - Airbag
    - Warning/indicator lights ..... 15
  - Airbag system ..... 108, 127
    - Care ..... 122
    - Child restraints ..... 132
    - Components (front airbags) ..... 115
    - Danger of fitting a child safety seat on the front passenger seat ..... 110
    - Disposal ..... 122
    - Front airbags ..... 112
    - How do the front airbags work? ..... 117
    - How many airbags does my vehicle have? ..... 115
    - Important safety instructions on the knee airbag system ..... 125
    - Important things to know ..... 108
    - Indicator light ..... 119
    - Knee airbags ..... 123
    - Monitoring ..... 119
    - PASSENGER AIR BAG OFF light ..... 119
    - Repairs ..... 122
    - Side airbags ..... 126
    - When must the system be inspected? . 119
  - All-wheel drive ..... 155
    - Winter tires ..... 211
  - Alloy wheels ..... 169
  - Alternator
    - refer to* Generator ..... 16
  - Anti-freeze
    - refer to* Engine cooling system ..... 187
  - Anti-lock brake system
    - Warning/indicator lights ..... 18
  - Anti-lock braking system ..... 150
  - Anti-slip regulation ..... 150
  - Anti-theft systems
    - Anti-theft alarm system ..... 38
    - Electronic immobilizer ..... 33
  - Ashtray ..... 62
  - Asterisk
    - What does it mean when something is marked with an asterisk? ..... 6
  - Audi magnetic ride ..... 21, 78
    - Description ..... 78
    - Indicator light ..... 21
  - Audi Service Repair Manuals and Literature ..... 243
  - Automatic belt retractor ..... 104
  - Automatic car wash
    - refer to* Washing ..... 165
  - Automatic transmission ..... 80
    - Driving Notes ..... 82
    - Emergency program ..... 85
    - Emergency release ..... 86
    - Ignition key safety lock ..... 72
    - Kick-down ..... 85
    - Launch Control Program ..... 85
    - Selector lever lock ..... 81
    - Selector lever positions ..... 80
    - Tiptronic ..... 84
    - Tiptronic controls on the steering wheel 84
  - Auto Safety Hotline ..... 98
  - Average fuel mileage ..... 23
  - Average speed ..... 23
  - Avoid damaging the vehicle ..... 160
- B**
- Battery ..... 190, 193
    - Charging ..... 193
    - Checking battery acid level ..... 193

- Connecting ..... 190  
 Disconnecting ..... 190  
 Important warnings ..... 192  
 Location ..... 192  
 Low ..... 156  
 Replacing the battery ..... 191  
 State of charge ..... 156  
 Winter operation ..... 190  
 Working on the battery ..... 192  
 Battery voltage ..... 19  
 Before driving ..... 90  
 Blended gasoline ..... 176  
 Body cavity sealing ..... 170  
 Boost ..... 28  
 Booster seats ..... 138  
 Boost pressure indicator ..... 28  
 Brake fluid  
   Changing the brake fluid ..... 190  
   Checking the brake fluid level ..... 189  
   What is the correct brake fluid level? .. 189  
   What should I do if the brake fluid warn-  
   ing light comes on? ..... 189  
 Brake fluid reservoir ..... 189  
 Brake system ..... 189  
   Anti-lock brake system ..... 18  
   Brake assist system ..... 150  
   Brake fluid ..... 189  
   Brake fluid specifications for refill and re-  
   placement ..... 190  
   Brake light defective ..... 20  
   Brake pads ..... 159  
   General information ..... 153  
   How does the moisture or road salt affect  
   the brakes? ..... 153  
   Malfunction ..... 14  
   Warning/indicator lights ..... 14  
   Worn brake pads symbol ..... 18  
 Break-in period ..... 159  
   Brake pads ..... 159  
   Tires ..... 159  
 Bulbs ..... 231
- C**
- California Proposition 65 Warning ..... 181  
   Battery specific ..... 193  
 Capacities ..... 240  
 Car care ..... 164  
   Interior ..... 170  
   Plastic and vinyl ..... 168  
 Care of exterior ..... 164  
 Cargo area  
   *refer to* Luggage compartment ..... 96  
 Catalytic converter ..... 160  
 CD changer ..... 64  
 Certification ..... 246  
 Changing a flat tire ..... 224  
 Changing engine oil ..... 186  
 Chassis  
   Undercoating ..... 170  
   *also refer to* Audi magnetic ride ..... 78  
 Checking  
   Battery acid level ..... 193  
   Engine coolant level ..... 187  
 Checking tire pressure ..... 202  
 Child restraint  
   Danger of using child restraints in the  
   front seat ..... 110  
 Child restraints  
   Where can I get additional information  
   about child restraints and their use? .. 149  
 Child restraint system anchors ..... 143  
 Child safety ..... 130  
   Convertible locking retractor ..... 140  
   Guidance fixtures for lower anchorages 145  
   Important safety instructions for using  
   child safety seats ..... 133  
   Important things to know when driving  
   with children ..... 130  
   Installing a child restraint using the  
   LATCH system ..... 146  
   Mounting and releasing the anchorage  
   hook ..... 146  
   Tether anchors ..... 147  
   Tether straps ..... 147  
 Child safety seat ..... 135  
   Convertible locking retractor ..... 140  
   Installing ..... 140  
   Unused safety belts on the rear seat .. 135  
 Child safety seats  
   Booster seats ..... 138  
   Convertible child seats ..... 136  
   How do I properly install a child safety  
   seat in my vehicle? ..... 133

- Infant seats ..... 135
  - LATCH system ..... 146
  - Safety instructions ..... 133
  - Child seats
    - Lower anchorages ..... 144
  - Cigarette lighter ..... 63
  - Cleaning
    - Alcantara (synthetic suede) ..... 173
    - Engine compartment ..... 174
    - Exhaust tail pipes ..... 170
    - Fabrics and fabric coverings ..... 171
    - Instrument panel ..... 171
    - Interior ..... 170
    - Leather ..... 173
    - Matte finish paint ..... 166
    - Navigation display ..... 170
    - Plastic and vinyl ..... 168
    - Plastic parts ..... 171
    - Radio display ..... 170
    - Safety belts ..... 174
    - Trim strips ..... 168
  - Cleaning and protection ..... 164
  - Climate controls ..... 66
    - A/C operation ..... 69
    - Air distribution ..... 68
    - Air recirculation mode ..... 69
    - Automatic mode ..... 69
    - Controls ..... 66
    - Defrost ..... 69
    - Economical use ..... 69
    - Fan ..... 67
    - Heated seats ..... 70
    - Heating ..... 66
    - Pollutant filter ..... 66
    - Rear window defogger ..... 70
    - Switching on and off ..... 67
    - Temperature ..... 67
    - Ventilation ..... 66
  - Clock ..... 11
  - Clutch overheating ..... 85
  - Clutch pedal
    - Indicator light ..... 17
  - Coat hooks ..... 65
  - Cold tire inflation pressure ..... 200
  - Coming home ..... 43
  - Compass mirror ..... 52
  - Compliance ..... 246
  - Consumer Information ..... 98, 243
  - Contacting NHTSA ..... 98
  - Controls and displays ..... 8
  - Convenience close/open feature
    - Windows ..... 40
  - Convertible child safety seats ..... 136
  - Convertible locking retractor
    - Activating ..... 142
    - Deactivating ..... 143
    - Using to secure a child safety seat 140, 142
  - Cooling system ..... 187
    - Expansion tank ..... 187
  - Cornering light ..... 43
  - Cruise control ..... 76
    - Changing speed ..... 77
    - Presetting your speed ..... 77
    - Switching off ..... 77
    - Switching on ..... 76
    - Warning/indicator lights ..... 21
  - Cup holder ..... 62
  - Current fuel mileage ..... 23
- ## D
- Damping
    - refer to* Audi magnetic ride ..... 78
  - Data ..... 240
  - Data recorder ..... 150
  - Date display ..... 11
  - Daytime running lights ..... 42
  - Declaration of compliance
    - Cell phone package ..... 246
    - Electronic immobilizer ..... 246
    - HomeLink® universal remote control .. 246
    - Remote control key ..... 246
  - def
    - What does this mean when it appears in the trip odometer display? ..... 12
  - Defective light bulb warning ..... 20
  - Defrosting the windows ..... 69
  - Determining correct load limit ..... 205
  - Digital clock ..... 11
  - Digital compass ..... 52
  - Dimensions ..... 239
  - Dimming the rearview mirror ..... 47
  - Dipstick
    - Reading the dipstick properly ..... 185

- Distance ..... 23
- Driver information system
- Boost ..... 28
  - Engine oil temperature display ..... 26
  - Engine oil temperature indicator ..... 28
  - Menu button ..... 25
  - Menu display ..... 24
  - Open door or front lid warning ..... 22
  - Outside temperature display ..... 22
  - Red symbols ..... 13
  - Service interval display ..... 28
  - Setting ..... 26
  - Sound system display ..... 22
  - Trip computer ..... 23
  - yellow symbols ..... 13
- Driver seat
- refer to* Seating position ..... 91
- Driving
- Run-flat tires ..... 218
- Driving safely ..... 90
- Driving through water ..... 160
- Duplicate key ..... 32
- Dust filter ..... 67
- E**
- Efficiency program ..... 26
- Fuel economy messages ..... 27
  - Memory levels ..... 23
  - Other equipment ..... 27
- Elapsed time ..... 23
- Electro-mechanical power assist ... 17, 155
- Electronic differential lock (EDL) ..... 150
- Warning/indicator lights ..... 18
- Electronic immobilizer ..... 12, 33
- Electronic power control
- EPC warning/indicator light ..... 19
- Electronic speed limiter ..... 31
- Electronic Stability Control (ESC)
- Warning/indicator lights ..... 17
- Electronic Stabilization Control (ESC) ... 150
- Emergency flasher ..... 45
- Warning/indicator lights ..... 21
- Emergency locking ..... 37
- Emergency operation
- Rear lid ..... 38
- Emergency starting ..... 232
- Emergency towing ..... 234
- Energy management ..... 156
- Battery power ..... 157
  - Driver notification ..... 157
- Engine
- Checking and filling locations ..... 182
  - Coolant ..... 187
  - Hood ..... 180
  - Starting ..... 71, 72
  - Starting with jumper cables ..... 232
  - Stopping ..... 73
- Engine compartment ..... 182
- Safety instructions ..... 180
  - Working in the engine compartment .. 180
- Engine coolant system
- Malfunction ..... 16
  - Radiator fan ..... 189
  - Temperature gauge ..... 11
- Engine cooling system ..... 187
- Adding coolant ..... 188
  - Checking the engine coolant level ..... 187
- Engine data ..... 240
- Engine hood
- Closing ..... 180
  - How to release the hood ..... 180
- Engine oil ..... 182
- Adding ..... 185
  - Additives ..... 185
  - Changing ..... 186
  - Checking the engine oil level ..... 185
  - Indications and conditions requiring extra checking ..... 185
  - Oil consumption ..... 184
  - Oil grades ..... 182
  - Recommended oil check intervals ..... 185
  - Specification and viscosity ..... 182
  - Temperature display ..... 26
- Engine oil level ..... 19
- Engine oil pressure (malfunction) ..... 16
- Engine oil sensor defective ..... 19
- Engine oil temperature indicator ..... 28
- Engine speed limitation ..... 19
- Environment
- Break-in period ..... 159
  - Catalytic converter ..... 160
  - Disposing of your vehicle battery ..... 191
  - Driving at high speeds ..... 161

- Driving to minimize pollution and noise 161
- Fuel ..... 178
- Fuel economy ..... 161
- Leakage from your vehicle ..... 180
- Letting the vehicle stand and warm up . 162
- Proper disposal of drained brake fluid . 190
- Proper disposal of drained engine coolant ..... 188
- Proper disposal of drained engine oil ..... 185, 186
- Recycling used engine oil ..... 185
- Unleaded fuel ..... 176
- What should I do with an old battery? . 191
- EPC  
*refer to* Electronic power control ..... 19
- ESC (Electronic Stabilization Control)  
 Warning/indicator lights ..... 17
- Event Data Recorder (EDR) ..... 150
- Exhaust tail pipes  
 Cleaning ..... 170
- Expansion tank ..... 187
- Exterior mirrors  
 Adjusting ..... 47  
 Dimming ..... 47  
 Heating ..... 47
- F**
- Fan ..... 67  
 Radiator ..... 189
- Fastening  
 Booster seats ..... 138  
 Convertible child safety seats ..... 136  
 Infant seats ..... 135
- Fastening eyelets ..... 59
- Flat tire  
 Changing ..... 224
- Floor mats ..... 95
- Fog lights ..... 44
- Folding master key with remote control .. 32
- Foot pedals ..... 95
- For the sake of the environment  
 Gasoline fumes and the environment .. 178  
 Letting your engine warm up ..... 72  
 Refueling ..... 178  
 Saving fuel by early upshifting ..... 10
- Front airbags  
 Description ..... 112  
 How they work ..... 117
- Frontal collisions and the laws of physics 101
- Front seats ..... 54  
 Adjusting ..... 92  
 Adjusting the manual seats ..... 55  
 Child restraints in the front seat ..... 110
- Fuel  
 Additives ..... 176  
 Blended gasoline ..... 176  
 Current fuel mileage ..... 23  
 Filler neck ..... 177  
 Fuel gauge ..... 12  
 Fuel supply too low ..... 20  
 Gasoline ..... 176  
 Gasoline additives ..... 177  
 Octane rating ..... 176  
 Recommendation ..... 176  
 Refuelling ..... 178  
 Reserve ..... 12  
 Tank capacity ..... 240  
 Unlocking the fuel filler flap by hand .. 179
- Fuel economy messages (efficiency program) ..... 27
- Fuse arrangement ..... 229
- G**
- Garage door opener (HomeLink®) ..... 87
- Gas discharge lamps ..... 231
- Gauges  
 Engine coolant temperature ..... 11  
 Fuel gauge ..... 12  
 Tachometer ..... 10
- Gearshift lever ..... 80
- General illustration  
 Instruments and controls ..... 8
- Generator  
 Warning/indicator lights ..... 16
- Glossary of tire and loading terminology 197
- Glove compartment ..... 64
- Gross Vehicle Weight Rating (GVWR) ... 238

**H**

Headlights	42
adaptive light	43
defective	20
Front fog lights	44
Switching off	42
Switching on	42
Washer system	50
Xenon headlights	42
Head restraints	94
Adjusting	94
Heated	
exterior mirrors	47
front seats (climate control)	70
rear window	70
Heated seats	70
Heated washer jets	
Wiper and washer system	48
Heating	66
High beam	42, 44
High voltage warning label	238
Hill Descent Assist	83
Hill hold assist	
Starting on hills	74
HomeLink® universal remote control	87
Hood	
Opening	180
Release lever	180
Horn	8
How are child restraint system anchors related to child safety	143
How many airbags does my vehicle have?	115
How often should I check my tire pressures?	203
How safety belt pretensioners work	106
Hydroplaning	207

**I**

Ignition key	71
Ignition key safety lock	72
Ignition lock	71
Ignition lock positions	71
Immobilizer	12
Important things to do before driving	90
Improperly worn safety belts	106

## Indicator light

Airbag system	119
Audi magnetic ride	21
Clutch overheating	85
PASSENGER AIR BAG OFF	119

## Indicator lights

Red symbols in the center display	13
Yellow symbols in the center display	13
<i>also refer to Warning/indicator lights</i>	12

## Infant seats

## Installing child safety seats

Safety belts	140
--------------	-----

## Installing the upper tether strap on the

## anchorage

	148
--	-----

## Instrument cluster and controls

## Instrument panel illumination

	46
--	----

## Instruments and controls

General illustration	8
----------------------	---

## Interior lights

Luggage compartment	46
---------------------	----

## Interlock switch

	17
--	----

**J**

## Jump-starting

	232
--	-----

## Jumper cables

	233
--	-----

**K**

## Key

Battery replacement	33
---------------------	----

Check light	32
-------------	----

Convenience opening and closing of windows	40
--	----

Emergency key	32
---------------	----

Key replacement	32
-----------------	----

Master key	32
------------	----

Valet key	32
-----------	----

## Keyless entry remote control

	33
--	----

## Kick-down

	85
--	----

## Knee airbags

Description	123
-------------	-----

How they work	125
---------------	-----

Important safety instructions	125
-------------------------------	-----

**L**

## Lap timer

	29
--	----

- LATCH ..... 143  
 Description ..... 144  
 Guidance fixtures for lower anchorages 145  
 Installing a child restraint ..... 146  
 Location ..... 144  
 Mounting and releasing the anchorage  
 hook ..... 146  
 Launch Control Program ..... 85  
 Leather ..... 172  
 Cleaning ..... 173  
 Leaving home ..... 43  
 Lifting jack ..... 225  
 Lifting vehicle ..... 237  
 Light/rain sensor defective ..... 21  
 Lights ..... 42  
 Coming/Leaving home ..... 43  
 Emergency flasher ..... 45  
 Exterior lighting ..... 43  
 Front fog lights ..... 44  
 Headlights ..... 42  
 High beam ..... 42, 44  
 Instrument panel illumination ..... 46  
 Side marker lights ..... 42  
 Turn signals ..... 44  
 Xenon headlights ..... 42  
 Loading the luggage compartment ..... 96  
 Loading the roof rack ..... 61  
 Locking  
 Power locking switch ..... 36  
 Rear lid/trunk lid ..... 37  
 Remote master key ..... 35  
 Using the key ..... 36  
 Lower universal anchorage bars (Canada) 143  
 Lower universal anchorages (Canada) ... 143  
 Luggage compartment  
 Cover ..... 60  
 Expanding ..... 59  
 Fastening eyelets ..... 59  
 Light ..... 46  
 Loading ..... 96
- M**
- Maintenance ..... 243  
 Malfunction Indicator Lamp (MIL) .. 19, 30  
 Manual transmission ..... 80  
 Gearshift lever ..... 80
- Master key ..... 33  
 Battery replacement ..... 33  
 Matte finish paint ..... 166  
 Menu button ..... 25  
 Menu display ..... 24  
 Mirrors  
 Activating the digital compass ..... 52  
 Adjusting the exterior mirrors ..... 47  
 dimming ..... 47  
 Monitoring the Advanced Airbag System 119
- N**
- Natural leather ..... 172  
 New tires and wheels ..... 207  
 NHTSA  
 Contacting ..... 98  
 Number of seats ..... 100
- O**
- Occupant seating positions ..... 91  
 Octane rating ..... 176  
 Odometer ..... 12  
 Oil  
*refer to* Engine oil ..... 182  
 On-Board Diagnostic System (OBD)  
 Data Link Connector (DLC) ..... 30  
 Electronic speed limiter ..... 31  
 Malfunction Indicator Lamp (MIL) ..... 30  
 Open door or front lid warning ..... 22  
 Operate your vehicle economically and  
 minimize pollution ..... 161  
 Optional equipment  
 Marked with an asterisk ..... 6  
 Other equipment (efficiency program) ... 27  
 Outlets ..... 63  
 Outside mirrors  
*refer to* Exterior mirrors ..... 47  
 Outside temperature display ..... 22  
 Owner's manual  
 How the Owner's Manual is organized ... 6
- P**
- Paint  
 Touch-up ..... 168  
 Paint No. .... 238

- Park assist ..... 78
- Parking ..... 74, 82
- Parking brake ..... 73
- Parking brake warning ..... 15
- Parking on a decline (downhill) ..... 74
- Parking on an incline (uphill) ..... 74
- Parts replacement ..... 245
- PASSENGER AIR BAG OFF light ..... 119
- Passive safety system ..... 90
- Pedals ..... 95
- Physical principles of a frontal collision . 101
- Polishing ..... 167
- Pollen filter ..... 67
- Pollutant filter ..... 67
- Power locking switch ..... 36
- Power locking system ..... 34
- Convenience close/open feature ..... 40
- Locking and unlocking the vehicle from  
    inside ..... 36
- Opening and closing the windows ..... 40
- Rear lid/trunk lid ..... 37
- Remote control ..... 33
- Unlocking and locking vehicle ..... 35
- Power outlets ..... 63
- Power seats
- Adjustment ..... 56
- Power steering
- refer to* Electro-mechanical power as-  
    sist ..... 17, 155
- Power window switches ..... 39
- Reactivating the system ..... 41
- Pregnant women
- Special considerations when wearing a  
    safety belt ..... 105
- Programming the HomeLink® universal re-  
mote control ..... 87
- Proper occupant seating positions ..... 91
- Proper safety belt position ..... 105
- Proper seating position
- Front passenger ..... 92
- Occupants ..... 91
- Rear passengers ..... 93
- Q**
- Quartz clock ..... 11
- quattro®
- refer to* All-wheel drive ..... 155
- Question
- What happens to unbelted occupants? 102
- Why safety belts? ..... 100
- R**
- Radiator fan ..... 189
- Rain sensor defective ..... 21
- Reading lights ..... 45
- Rear lid ..... 37
- Emergency release ..... 38
- Rear light defective ..... 20
- Rear spoiler ..... 153
- Rear view mirror ..... 47
- Rear window defogger ..... 70
- Rear window shelf ..... 58
- Refuelling ..... 178
- Release lever for hood ..... 180
- Remote control ..... 33, 36
- Remote control garage door opener  
(HomeLink®) ..... 87
- Remote master key
- Unlocking and locking ..... 35
- Remote rear lid release ..... 37
- Repair manuals ..... 243
- Repairs
- Airbag system ..... 122
- Replacement parts ..... 245
- Replacing
- Wheel rims ..... 207
- Replacing a fuse ..... 228
- Replacing light bulbs ..... 231
- Replacing tires and wheels ..... 208
- Replacing windshield wiper blades ..... 51
- Reporting Safety Defects ..... 98
- Reset button ..... 12
- Resetting remote control ..... 36
- Retractor ..... 104
- Reverse (Automatic transmission) ..... 81
- Rims
- Cast alloy ..... 169
- Replacing ..... 207
- Steel rims ..... 169

- Roof rack  
 Loading ..... 61  
 Mounting locations ..... 61  
 Safe mounting ..... 60
- Roof weight ..... 61
- Run-flat tires ..... 217  
 Driving ..... 218  
 Introduction ..... 217  
 Replacing defects parts ..... 219
- S**
- SAFE ..... 12
- Safe driving habits ..... 90
- Safety belt position ..... 105  
 Safety belts worn by pregnant women . 105
- Safety belt pretensioner  
 Service and disposal ..... 107
- Safety belts ..... 104  
 Cleaning ..... 174  
 Danger to passengers who do not wear a  
 safety belt ..... 102  
 Fastening ..... 104  
 Improperly worn ..... 106  
 Not worn ..... 102  
 pretensioners ..... 106  
 Safety belt position ..... 105  
 Safety instructions ..... 103  
 Securing child safety seats ..... 140  
 Special considerations for pregnant  
 women ..... 105  
 Unfastening ..... 106  
 Warning/indicator light ..... 100  
 Why YOU MUST wear them ..... 100  
 Worn properly ..... 102
- Safety belt warning light ..... 16, 100
- Safety compliance sticker ..... 238
- Safety equipment ..... 90
- Safety features for occupant restraint and  
 protection ..... 90
- Safety guidelines  
 Seat adjustment ..... 54
- Safety instructions  
 Engine compartment ..... 180  
 for using child safety seats ..... 133  
 For using safety belts ..... 103  
 Monitoring the Advanced Airbag Sys-  
 tem ..... 121
- Safety lock (Ignition key) ..... 72
- Seat adjustment  
 Driver's seat ..... 54  
 Front passenger's seat ..... 55  
 Front seats ..... 54  
 Head restraints ..... 94  
 Head restraints, front seat ..... 57  
 Manual controls ..... 55  
 Power seats ..... 56  
 Safety guidelines ..... 54  
 seatback angle ..... 55
- Seating capacity ..... 100
- Seating position  
 Driver ..... 91  
 Front passenger ..... 92  
 How to adjust the front seats ..... 92  
 Incorrect seat position ..... 94  
 Occupants ..... 91  
 Rear passengers ..... 93
- Seats  
 Number of seats ..... 100
- Selector lever emergency release ..... 86
- Selector lever positions ..... 80
- Service and disposal  
 Safety belt pretensioner ..... 107
- Service interval display ..... 28
- Service position for windshield wipers ... 50
- Set menu ..... 26
- Setting  
 Date display ..... 11  
 Digital clock ..... 11
- Side airbags  
 Description ..... 126  
 How they work ..... 127
- Side marker lights ..... 42
- Snow chains ..... 212
- Sockets ..... 63
- Sound system display ..... 22
- Sources of information about child re-  
 straints and their use ..... 149
- Speedometer ..... 12
- Speed rating letter code ..... 208
- Speed warning system ..... 74
- Sport button ..... 78
- Sport mode ..... 78, 152
- Starting assistance ..... 233

- Starting on hills  
Hill hold assist ..... 74
- Starting the engine ..... 71, 72  
What should I do if the engine does not start? ..... 72
- Steel wheels ..... 169
- Steering  
*refer to* Electro-mechanical power assist ..... 17, 155
- Steering column  
Adjusting ..... 71  
Locking the steering ..... 71
- Steps for determining correct load limit . 205
- Stopping the engine ..... 73
- Storage ..... 64  
Compartment in the front seats ..... 64  
Cup holder ..... 62  
Glove compartment ..... 64
- Storage compartment  
Expanding ..... 59
- St ronic ..... 80  
Driving Notes ..... 82  
Emergency program ..... 85  
Emergency release ..... 86  
Kick-down ..... 85  
Launch Control Program ..... 85  
Selector lever lock ..... 81  
Selector lever positions ..... 80  
Tiptronic ..... 84  
Tiptronic controls on the steering wheel 84
- Sun visors ..... 46
- Switches  
Emergency flasher ..... 45
- Symbols  
Red symbols in the center display ..... 13  
Yellow symbols in the center display ... 13  
*also refer to* Warning/Indicator lights .. 12
- T**
- Tachometer ..... 10
- Tank flap  
Unlocking the fuel filler flap by hand .. 179
- Technical modifications ..... 246
- Temperature ..... 67
- Temperature display  
Engine oil ..... 26
- Tether anchors ..... 147
- Tether strap ..... 147
- The first 1,000 miles (1,500 km) and afterwards ..... 159
- Tie-downs ..... 59, 97
- Tightening wheel bolts ..... 224
- Tips for the environment  
Saving fuel ..... 62
- Tire mobility system ..... 220
- Tire pressure ..... 202
- Tire pressure monitoring system ..... 214  
Loss of air pressure ..... 215  
Malfunction ..... 215  
Resetting tire pressures ..... 216, 217
- Tire repair kit ..... 220
- Tires ..... 196  
Replacing ..... 207  
run-flat ..... 217  
Service life ..... 206  
speed rating letter code ..... 208  
Tire manufacturing date ..... 208  
Tire specifications ..... 208  
Tread depth ..... 206  
Uniform tire quality grading ..... 210  
Winter tires ..... 211
- Tires/Wheels  
Low aspect ratio tires ..... 213  
Tire mobility system ..... 220  
Tire pressure monitoring system ..... 214  
Tire repair kit ..... 220
- Tires and vehicle load limits ..... 204
- Tires and wheels  
Checking tire pressure ..... 202  
Cold tire inflation pressure ..... 200  
Dimensions ..... 207  
General notes ..... 196  
Glossary of tire and loading terminology ..... 197  
New tires and wheels ..... 207  
Replacing ..... 208  
Snow chains ..... 212  
Tires and vehicle load limits ..... 204  
Wheel bolts ..... 213  
Winter tires ..... 211
- Tire service life ..... 206
- Tool kit ..... 220
- Touch-up paint ..... 168

Towing  
 Front eyelet ..... 235  
 Rear eyelet ..... 236  
 Tow truck procedures ..... 234

Towing loop  
 front ..... 235

TPMS  
 Tire pressure monitoring system ..... 215

Trailer towing ..... 163

Transmission  
 Manual transmission ..... 80  
 S tronic transmission ..... 80

Transport Canada ..... 98

Tread Wear Indicator (TWI) ..... 206

Trip computer ..... 23  
 Single-trip memory ..... 23  
 Total-trip memory ..... 23

Trip odometer ..... 12  
 What does it mean when dEF appears in  
 the trip odometer display? ..... 12

Trunk lid ..... 37

Turn signals ..... 44  
 Warning/indicator lights ..... 21

**U**

Undercoating ..... 170

Unfastening safety belts ..... 106

Unidirectional tires ..... 196

Uniform tire quality grading ..... 210

Universal Radio- Frequency Remote Control (HomeLink®) ..... 87

Unlocking  
 Power locking switch ..... 36  
 Rear lid/trunk lid ..... 37  
 Remote control key ..... 35  
 Using the key ..... 36

**V**

Vanity mirror ..... 46

Vehicle-care products ..... 164

Vehicle electrical system ..... 16

Vehicle Identification Number (VIN) ..... 238

Vehicle jack ..... 225

Vehicle literature ..... 5

Vehicle tool kit ..... 220

Ventilation ..... 66

**W**

Warning/indicator lights ..... 10, 12  
 Airbag system ..... 15  
 Anti-lock brake system (ABS) ..... 18  
 Brake system ..... 14  
 Cruise control ..... 21  
 Electronic power control ..... 19  
 Electronic Stabilization Control (ESC) ... 17  
 Generator ..... 16  
 Malfunction Indicator Lamp (MIL) ..... 19  
 Parking brake ..... 14  
 Safety belt ..... 16  
 Safety systems ..... 15  
 Turn signals ..... 21

Warning/Indicator lights  
 Rear spoiler ..... 21

Warning lights  
 Red symbols in the center display ..... 13  
 Yellow symbols in the center display ... 13

Warranty coverages ..... 243

Washer reservoir ..... 194

Washing ..... 164  
 Automatic car wash ..... 165  
 by hand ..... 165  
 General information ..... 164  
 Matte finish paint ..... 166  
 with a power washer ..... 166

Waxing ..... 167

Wear indicator ..... 206

Weights ..... 238

What happens if you wear your safety belt  
 too loose? ..... 105

What happens to unbelted occupants? .. 102

What impairs driving safety? ..... 91

What should I do after changing a  
 wheel? ..... 203

What should I do after replacing wheels? 203

Wheel bolts  
 Torque ..... 213

Wheels ..... 196  
 Cast alloy ..... 169  
 Checking tire pressure ..... 202  
 Cold tire inflation pressure ..... 200  
 General notes ..... 196

- Glossary of tire and loading terminology . . . . . 197
- New tires and wheels . . . . . 207
- Tires and vehicle load limits . . . . . 204
- Wheels/Tires
  - Steel wheels . . . . . 169
- When must the airbag system be inspected? . . . . . 119
- When should I adjust the tire pressures? 203
- When should I check the tire pressures? . 203
- Where are lower anchorages located? . . . 144
- Where can I find the tire pressures for my car? . . . . . 202
- Why safety belts? . . . . . 100, 101
- Windows
  - Cleaning . . . . . 168
  - Convenience close/open feature . . . . . 40
  - Defrost . . . . . 69
- Windshield washer fluid . . . . . 20
- Windshield wipers
  - Folding up . . . . . 51
  - Replacing windshield wiper blades . . . . . 51
  - Service position . . . . . 50
  - Washer fluid reservoir . . . . . 194
- Winter operation
  - Battery . . . . . 190
  - Coolant system . . . . . 187
  - Defrosting windows . . . . . 69
  - Heated seats (climate control) . . . . . 70
  - Tires . . . . . 155
  - Windows . . . . . 168
- Winter tires . . . . . 211
  - All-wheel drive . . . . . 211
- Wiper and washer system . . . . . 48
  - Intermittent wiping . . . . . 48
  - One-tap wiping . . . . . 48
  
- X**
  - Xenon-Lights . . . . . 231

It has always been Audi's policy to continuously improve its products. Audi, therefore, reserves the right to make changes in design and specifications, and to make additions or improvements in its products, without incurring any obligation to install them on products previously manufactured.

Text, illustrations and specifications in this manual are based on the most up-to-date information available at the time of printing.

All rights reserved. May not be reproduced or translated in whole or in part without the

written consent of AUDI AG. Specifications are subject to change without notice.

"Audi", "quattro" and the four rings emblem are registered trademarks of AUDI AG.

**Editorial deadline: 09/07/2012**



**For the sake of the environment**

Printed on environmentally friendly paper (bleached without chlorine, recyclable).

Printed in Germany

© 2012 AUDI AG

**Owner's Manual**  
**2013 Audi TT | TTS | TT RS Coupe**  
**Englisch Nordamerika 11.2012**  
**132.561.8J3.21**



1325618J321

[www.audi.com](http://www.audi.com)