

Contents

A-Z

BMW M



The Ultimate
Driving Machine



THE BMW M4 COUPÉ.

OWNER'S HANDBOOK.

M4 **Owner's Handbook for the vehicle**

Congratulations on your choice of a BMW M4.

The better you are acquainted with your vehicle, the easier you will find it is to operate. We would therefore like to offer you the following advice:

Please read the Owner's Handbook before setting out in your new BMW M4. Also use the integrated Owner's Handbook in your vehicle. It contains important information on how to operate the vehicle, enabling you to derive maximum benefit from the technical advantages of your BMW M4. It also contains useful information which will help you to maintain both the operating and road safety of your BMW M4 as well as its full resale value.

If applicable, you will find updates after the editorial deadline in the appendix of the printed Owner's Handbook for the vehicle.

Supplementary information is provided in the other documents of on-board literature.

We wish you a safe and pleasant journey.



The Owner's Handbook is available as an app in many countries. You will find further information on the Internet at:

www.bmw.com/bmw_drivers_guide

© 2017 Bayerische Motoren Werke
Aktiengesellschaft
Munich, Germany
Not to be reproduced, wholly or in part, without written
permission from BMW AG, Munich.
English ID5 VI/17, 07 17 490
Printed on environmentally friendly paper, bleached
without chlorine, suitable for recycling.

Contents

For quick access to a particular topic or item, please consult the detailed alphabetical index, see page 254.

The topics of navigation, entertainment and communication can be called up using the following Owner's Handbooks: Integrated Owner's Handbook in the vehicle on the Control Display, Online Owner's Handbook, BMW Driver's Guide App.

6 Notes

Overview

- 14 Driving area
- 18 iDrive
- 27 Voice control system
- 30 General settings
- 43 Integrated Owner's Handbook in the vehicle

Controls

- 48 Opening and closing
- 66 Adjusting
- 77 Carrying children safely
- 85 Driving
- 101 Displays
- 120 Lights
- 126 Safety
- 149 Driving Stability Control Systems
- 155 Driving comfort
- 171 Air conditioning
- 180 Interior equipment
- 184 Storage compartments

Driving hints

- 190 BMW M4 Technology
- 192 Driving precautions
- 196 Loads
- 199 Saving fuel

Mobility

- 204 Refuelling
- 206 Fuel
- 207 Wheels and tyres
- 220 Engine compartment
- 223 Engine oil
- 227 Coolant
- 229 Maintenance
- 232 Replacing parts
- 237 Breakdown Assist
- 244 General care

Reference

- 250 Technical data
- 253 Appendix
- 254 Everything from A to Z

Notes

About this Owner's Handbook

Orientation

The quickest way to find information on a particular topic or feature is to consult the alphabetical index.

We recommend that you read through the first chapter to get an initial overview of the vehicle.

Updates after going to press

Updates following the copy deadline can result in differences between the printed Owner's Handbook and the following Owner's Handbooks:

- ▷ Integrated Owner's Handbook in the vehicle.
- ▷ Online Owner's Handbook.
- ▷ BMW Driver's Guide App.

You will find notes on any updates in the appendix of the printed Owner's Handbook for the vehicle.

Owner's Handbook for Navigation, Entertainment, Communication

The Owner's Handbook for navigation, entertainment and communication is available as a printed book from Service.

The topics of navigation, entertainment and communication can be called up using the following Owner's Handbooks:

- ▷ Integrated Owner's Handbook in the vehicle on the Control Display.
- ▷ Online Owner's Handbook.
- ▷ BMW Driver's Guide App.

Additional sources of information

Service Partner

A Service Partner of the manufacturer will be happy to answer any further questions.

Internet

Owner's Handbook and general information about BMW, for example on technology, are available on the Internet: www.bmw.com.

BMW Driver's Guide App



The Owner's Handbook is available as an app in many countries. You will find further information on the Internet at:

www.bmw.com/bmw_drivers_guide

Symbols and displays

Symbols in the Owner's Handbook

⚠ Indicates precautions that must be followed precisely in order to avoid the possibility of personal injury and serious damage to the vehicle.

◀ Marks the end of a specific item of information.

♻ Refers to measures that can be taken to help protect the environment.

"..." identifies texts on a display in the vehicle for selecting functions.

>...< Identifies commands for the voice control system.

»...« Identifies replies by the voice control system.

Actions

The actions to be carried out are shown as a numbered list. The sequence of steps must be followed.

1. First action.
2. Second action.

Lists

Alternative options and lists of items with no implied sequence are shown as bullet point lists:

- ▷ First option.
- ▷ Second option.

Symbol for components and assemblies

 Recommends that you study the relevant section of this Owner's Handbook in connection with a particular part or assembly.

Vehicle equipment

This Owner's Handbook describes all models and all standard, national and special equipment available for the model series. As a result, this Owner's Handbook may also contain descriptions and illustrations of equipment and functions not featured in your vehicle, for example due to selected special equipment or country specification.

This also applies to safety-relevant functions and systems.

Comply with the relevant laws and regulations when using the corresponding functions and systems.

If certain equipment and models are not described in this Owner's Handbook, refer to the Supplementary Owner's Handbooks provided.

In right-hand drive vehicles, some controls are arranged differently from those shown in the illustrations.

Production date

The production date of your vehicle can be found at the bottom of the door pillar on the driver door.

The production date is defined as the calendar month and the calendar year in which the vehicle body and the powertrain assemblies are joined and the vehicle is driven or moved from the production line.

Status of the Owner's Handbook

General

Continuous development ensures high levels of vehicle safety and quality. In rare instances, your vehicle may therefore differ from the information supplied here.

For Australia/New Zealand: general

When reading this Owner's Handbook, please bear the following in mind: to ensure that our vehicles continue to embody the highest quality and safety standards, we pursue a policy of continuous, ongoing development. Because modifications in the design of both vehicles and accessories may be introduced at any time, your own vehicle's equipment may vary from that described in this handbook. For the same reason, it is also impossible to guarantee that all descriptions will be completely accurate in all respects.

We must therefore request your understanding of the fact that the manufacturer of your vehicle is unable to recognise legal claims based on discrepancies between the data, illustrations and descriptions in this Owner's Handbook and your own vehicle's equipment.

Please note, too, that some of the optional equipment described in this manual is not available on Australian models due to restrictions imposed by Australian Design Rules and other requirements.

Should you require any further information, please contact your Service Partner or a qualified specialist workshop, who will be pleased to advise you.

Updates after going to press

Updates following the copy deadline can result in differences between the printed Owner's Handbook and the following Owner's Handbooks:

- ▷ Integrated Owner's Handbook in the vehicle.
- ▷ Online Owner's Handbook.
- ▷ BMW Driver's Guide App.

You will find notes on any updates in the appendix of the printed Owner's Handbook for the vehicle.

Your own safety

Intended use

Comply with the following when using the vehicle:

- ▷ Owner's Handbook.
- ▷ Information on the vehicle. Do not remove stickers.
- ▷ Technical data of the vehicle.
- ▷ The applicable laws and safety standards of the country in which the vehicle is used.
- ▷ Vehicle papers and legal documents.

Warranty

Your vehicle is technically designed for the operating conditions and approval requirements prevalent in the country to which it was first delivered - homologation. If your vehicle is to be operated in another country, it may have to

be adapted to any prevailing different operating conditions and approval requirements. If your vehicle does not comply with the homologation requirements in a certain country you cannot lodge warranty claims for your vehicle there. A Service Partner is able to provide further information.

Maintenance and repairs

The advanced technology used in your vehicle, for example the state-of-the-art materials and high-performance electronics, requires suitably appropriate maintenance and repair methods.

Consequently, the manufacturer of your vehicle recommends having corresponding work carried out by a BMW Service Partner. If you select a different specialist workshop, BMW recommends that you select a workshop that can carry out the corresponding work such as maintenance and repair according to BMW specifications and works with appropriately trained personnel, referred to in this Owner's Handbook as another qualified Service Partner or a specialist workshop.

If such work, for example maintenance and repair, is performed inexpertly, it could result in consequential damage and thus constitute a safety risk.

Parts and accessories

BMW recommends using parts and accessory products that are specifically approved for this purpose by BMW.

You are recommended to consult a BMW Service Partner for advice on genuine BMW parts and accessories, other BMW approved products and expert advice on all related matters.

The safety and compatibility of these products in conjunction with BMW vehicles have been checked by BMW.

BMW accepts product responsibility for genuine BMW parts and accessories. BMW cannot

accept liability for parts or accessory products of any kind which it has not approved.

BMW is unable to assess each individual product of outside origin as to its suitability for use on BMW vehicles without safety risk. Nor can suitability be assured if an official permit has been issued for it in a specific country. Tests performed for such permits cannot always cover all operating conditions for BMW vehicles, and some of them therefore are insufficient.

Data memory

General

A number of electronic control devices are installed in your vehicle. Some of these are necessary for the vehicle to function safely or provide assistance during driving, for example Driver Assistance Systems. There are also control devices which manage comfort or infotainment functions.

Electronic control devices contain data memories, which are able to save information on the vehicle condition, component wear and condition, maintenance requirements, technical events or errors temporarily or permanently.

This information generally documents the condition of a component, a module, a system or its environment, for example:

- ▶ Operating states of system components, for example, fill levels, tyre pressure, battery status.
- ▶ Status messages of the vehicle and its individual components, for example wheel rotation speed, wheel speed, deceleration, lateral acceleration, fastened seat belt indicator.
- ▶ Malfunctions and faults of important system components, for example, lights and brakes.
- ▶ Information on vehicle-damaging events.

- ▶ Responses of the vehicle to particular driving situations, for example, triggering of an airbag, activation of the stability control systems.
- ▶ Ambient conditions, for example temperature, rain sensor signals.

The data is required to perform the control device functions. It is also used for detecting and rectifying malfunctions, and helps the vehicle manufacturer to optimise vehicle functions. The majority of this data is transient and is only processed within the vehicle itself. Only a small proportion of the data is stored in event or error memories and, if necessary, in the vehicle key.

Reading out data

When service work is being carried out, for example repairs, service operations, warranty work and quality assurance measures, this technical information can be read out from the vehicle together with the vehicle identification number. A Service Partner of the manufacturer or another qualified Service Partner or a specialist workshop can read out the information. The legally required on-board diagnostics (OBD) socket in the vehicle is used to read out the data. The data is collected, processed and used by the relevant organisations in the service network. The data documents the technical conditions of the vehicle, helps in locating faults and improving quality, and is transferred to the vehicle manufacturer, if necessary.

Furthermore, the manufacturer has product monitoring obligations to meet in line with product liability law. To fulfil these obligations, the vehicle manufacturer requires technical data from the vehicle. Error and event memories in the vehicle can be reset when a Service Partner of the manufacturer or another qualified Service Partner or a specialist workshop performs repair or servicing work.

Data on service work carried out and proof of maintenance is saved in the vehicle under the service history and transferred to the vehicle

manufacturer. The vehicle owner can contact a Service Partner of the manufacturer to object to the data being saved and transferred to the vehicle manufacturer. This objection applies for as long as the vehicle owner remains the proprietor of the vehicle.

Data entry and data transfer into the vehicle

General

Depending on the equipment, some data can be transferred into the vehicle when using comfort and infotainment functions, for example:

- ▷ Multimedia data such as music, films or photos for playback in an integrated multimedia system.
- ▷ Address book data for use in conjunction with an integrated hands-free system or an integrated navigation system.
- ▷ Entered navigation destinations.
- ▷ Data on the use of Internet services.

This data can be saved locally in the vehicle or is found on a device that has been connected to the vehicle, for example a smartphone, USB stick or MP3 player. If this data is saved in the vehicle, it can be deleted at any time. This data is only transmitted to third parties if expressly desired. This depends on the personal settings selected for using online services.

Depending on the equipment, the following comfort and individual settings can be saved in the vehicle and modified at any time, for example:

- ▷ Settings for the seat and steering wheel positions.
- ▷ Suspension and climate control settings.
- ▷ Individual settings, for example interior lighting.

Control via mobile user devices

Depending on the equipment, mobile end user devices connected to the vehicle, for example smartphones, can be controlled via the vehicle controls. The sound and picture from the mobile user device can be played back and displayed through the multimedia system. Certain information is transferred to the mobile user device at the same time. Depending on the type of connection, this includes, for example position data and other general vehicle information. This optimises the way in which selected apps, for example navigation or music playback, work.

There is no further interaction between the mobile user device and the vehicle, for example active access to vehicle data. How the data is processed further is determined by the provider of the particular app being used. The range of settings depends on the respective app and the operating system of the mobile user device.

Services

General

If the vehicle has a wireless network connection, this enables data to be exchanged between the vehicle and other systems. The wireless network connection is established via an in-vehicle transmitter and receiver unit or via personal mobile user devices brought into the vehicle, for example smartphones. This wireless network connection enables 'online functions' to be used. These include online services and apps supplied by the vehicle manufacturer or by other providers.

Services from the vehicle manufacturer

Where online services from the vehicle manufacturer are concerned, the relevant functions are described in the appropriate place, for example the Owner's Handbook or manufacturer's website. The relevant legal information

pertaining to data protection is also provided. Personal data may be used to perform online services. Data is exchanged over a secure connection, for example with the IT systems of the vehicle manufacturer intended for this purpose. Any collection, processing and use of personal data above and beyond that needed to provide the services must always be based on legal permission, a contractual arrangement or consent.

In addition, the vehicle manufacturer evaluates anonymised information on transport infrastructure and how the infotainment system is used. This information cannot be traced back to individual vehicles or people. Evaluating the data enables the manufacturer to further improve its products or services, for example by incorporating the most up-to-date traffic information. The data transfer feature can be deactivated in the vehicle. Certain services and functions, some of which are subject to a charge, can be deactivated by the driver. It is also possible to activate or deactivate the data connection as a whole. With the exception of functions and services required by law, for example emergency call systems.

Services from other providers

When using online services from other providers, these services are the responsibility of the relevant provider and subject to their data privacy conditions and terms of use. The vehicle manufacturer has no influence on the content exchanged when using these services. Information on the way in which personal data is collected and used in relation to services from third parties, the scope of such data and its purpose, can be obtained from the relevant service provider.

Vehicle identification number

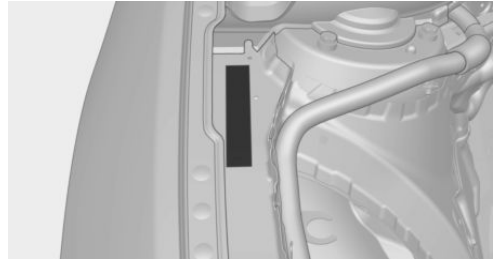

The vehicle identification number is in the engine compartment, on the right-hand side of the vehicle.



Overview

This chapter shows you the layouts of the different buttons, switches and displays. It also gets you quickly acquainted with the various operating concepts and options.

Driving area

Vehicle equipment

This chapter describes all standard, national and special equipment available for the model series. Therefore equipment which is not installed in your vehicle, for example on account

of the selected optional equipment or the country specification, may also be described here. This also applies to safety-relevant functions and systems. Comply with the relevant laws and regulations when using the corresponding functions and systems.

Around the steering wheel

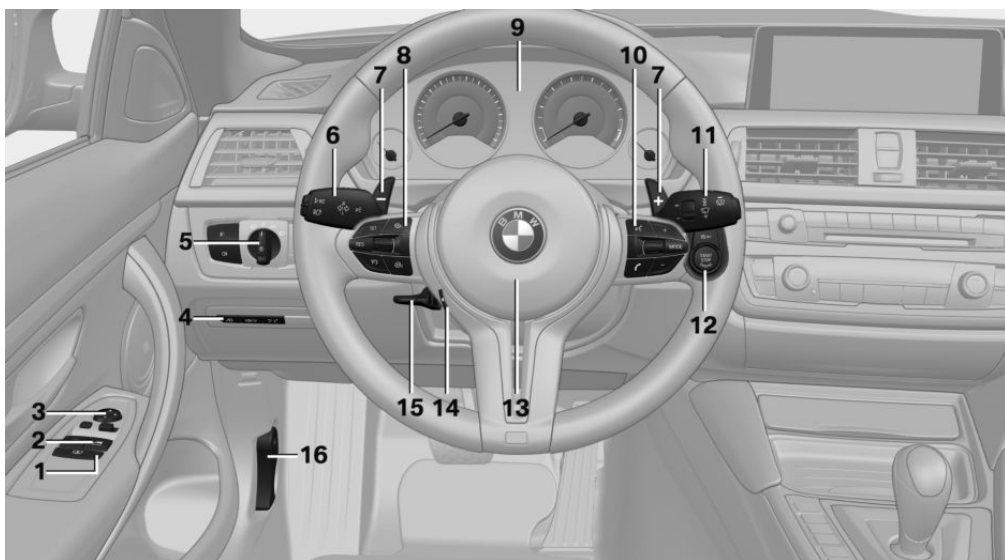

- 1 Roller sunblind for rear window [63](#)
 - 2 Power windows [62](#)
 - 3 Exterior mirror operation [74](#)
 - 4 Glove box on the driver's side [185](#)
- Driver Assistance Systems



Lane Change Warning [142](#)





























Intelligent Safety [134](#)



Lane Departure Warning [140](#)

5 Lights

-  Rear fog light 124
-  Light switch 120
-  Lights off
Daytime driving lights 122
-  Side lights 120
-  Low-beam headlights 120
-  Automatic driving lights control 121
Adaptive light functions 122
High-beam assistance 123
-  Instrument lighting 124
- 6** Steering-column lever, left
-  Turn indicator 90
-  High-beam headlights, headlight flasher 90
-  High-beam assistance 123
-  Parking lights 120
-  On-board computer 113
- 7** Shift paddles 98
- 8** Buttons on steering wheel, left
-  Activate M Drive 1 149
-  Activate M Drive 2 149
-  Speed limiter 144
-  Cruise Control on/off, interrupt 155
-  Cruise Control: to resume a speed
Rocker switch for Cruise Control
- 9** Instrument cluster 101
- 10** Buttons on steering wheel, right
-  Entertainment source, see Owner's Handbook for Navigation, Entertainment, Communication 6
-  Volume, see Owner's Handbook for Navigation, Entertainment, Communication 6
-  Voice control 27
-  Telephone, see Owner's Handbook for Navigation, Entertainment, Communication 6
- Knurled wheel for selection lists 112
- 11** Steering-column lever, right
-  Wiper 91
-  Rain sensor 92
-  Cleaning the windows and headlights 92
- 12**  Start/stop engine and switch ignition on/off 86
-  Auto Start Stop function 87
- 13**  Horn, entire area



14 Steering wheel heating 76

15 To adjust the steering wheel 76

16 To release the bonnet 221

Around the centre console

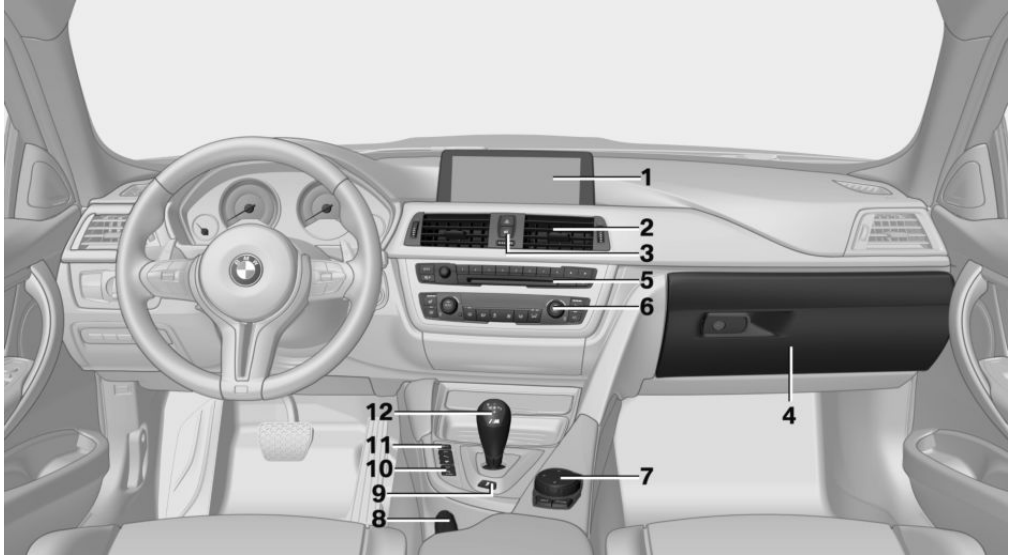

1 Control Display 18

2 Ventilation 177

3  Hazard warning lights 237

 Central locking system 52

4 Glove box 184

5 Radio/CD/Multimedia, see Owner's Handbook for Navigation, Entertainment, Communication 6

6 Climate 171

7 Controller with buttons 18

8 Parking brake 90

9  Drivelogic 98

10  Park Distance Control, PDC 157

Rear-view camera 160

Park Assistant 167

Surround view 160

 Side View 163

11  Dynamic Stability Control, DSC 150

 Engine Dynamics 100



Adaptive M chassis [153](#)

12 M double clutch transmission selector lever [95](#)





Servotronic [154](#)

Manual transmission selector lever [95](#)

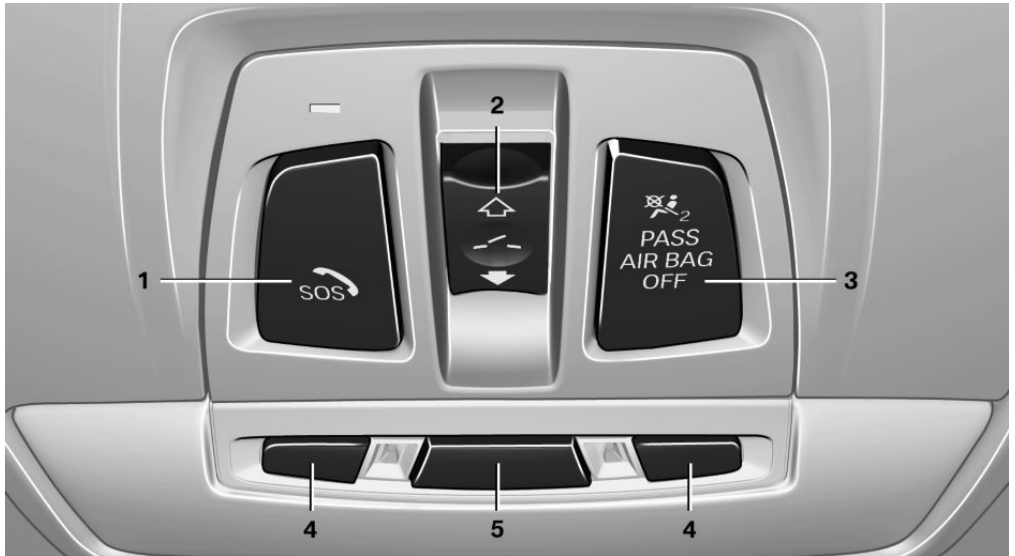
Around the roof lining



1  Emergency call, SOS [237](#)

4  Reading lights [124](#)

2  Glass Roof, electric [63](#)

5  Interior light [124](#)

3  Front passenger airbag indicator lamp [128](#)

iDrive

Vehicle equipment

This chapter describes all standard, national and special equipment available for the model series. Therefore equipment which is not installed in your vehicle, for example on account of the selected optional equipment or the country specification, may also be described here. This also applies to safety-relevant functions and systems. Comply with the relevant laws and regulations when using the corresponding functions and systems.

Principle

iDrive integrates the functions of a large number of switches. These functions can be operated using the Controller.

Safety note



WARNING

Operating integrated information systems and communication devices during the journey may distract you from the traffic. You could lose control of the vehicle. There is a danger of accidents. Only operate the systems or devices if permissible in the traffic situation. Stop if necessary and operate the systems or devices with the vehicle at a standstill. ◀

Controls

Overview

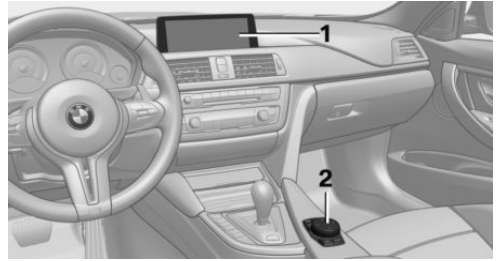

- 1 Control Display
- 2 Controller with buttons and touchpad, depending on equipment

Control Display

General

To clean the Control Display, comply with the information regarding care, see page 247.

Do not place objects in front of the Control Display, otherwise the Control Display may get damaged.

If the Control Display is exposed to very high temperatures, for example because of strong sunlight, there may be a reduction in brightness and the Control Display may even switch itself off. Normal functions will be restored when the temperature is reduced, for example by shading or using the air conditioning system.

Switching on

1. Switch on the ignition.
2. Press the Controller.

Switching off

1.  Press the button.

2. "Switch off control display"

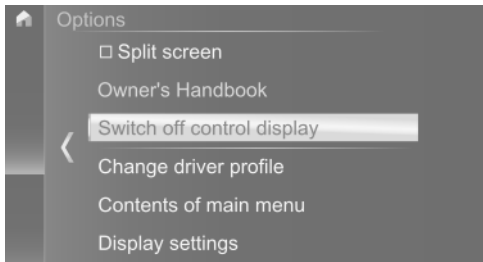

Controller with navigation system

General

The buttons can be used to call up menus directly. The Controller can be used to select menu items and perform settings.

Some of the functions of the iDrive can be operated with the touchpad of the Controller, see page 24.

Operation

- ▶ Turning.

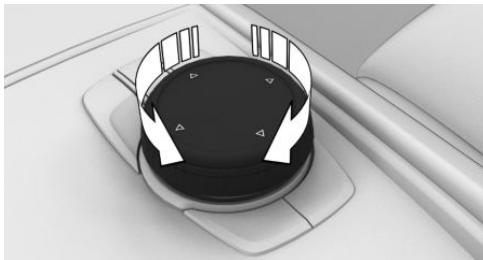



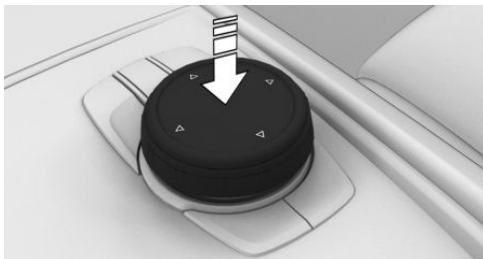

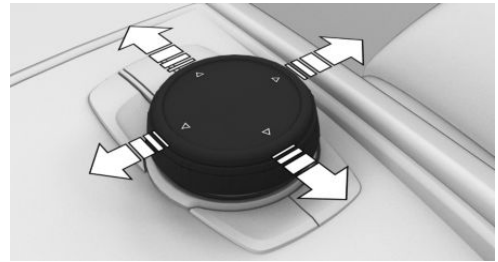

- ▶ Pressing.



- ▶ Tilting in four directions.



Buttons on the Controller

Button	Function
	Press once: calls up main menu. Press twice: shows all menu items of the main menu.
	Calls up Communication menu.
	Calls up Media/Radio menu.
	Calls up the Destination input menu of the navigation system.
	Calls up navigation map.
	Press once: calls up the previous screen. Press and hold: calls up the last menu used.
	Calls up the Options menu.

Controller without navigation system

General

The buttons can be used to call up menus directly. The Controller can be used to select menu items and perform settings.

Operation

- ▶ Turning.

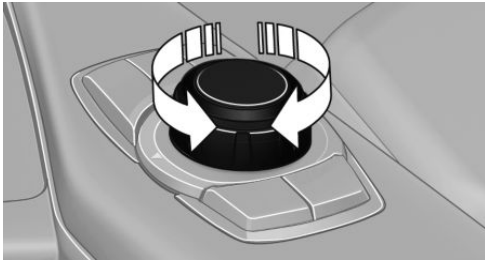

▷ Pressing.

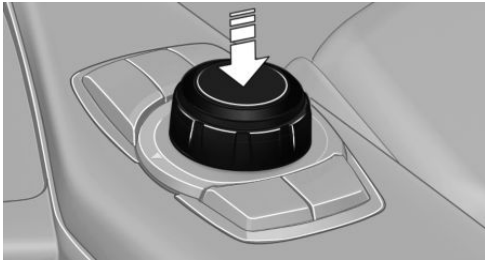

▷ Tilting in four directions.

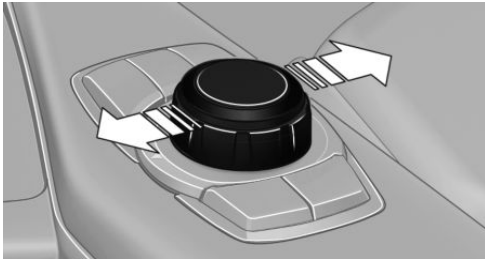

Buttons on the Controller

Button Function

MENU	Press once: calls up main menu. Press twice: shows all menu items of the main menu.
COM	Calls up Communication menu.
MEDIA	Calls up Media/Radio menu.

Button Function

BACK	Press once: calls up the previous screen. Press and hold: calls up the last menu used.
OPTION	Calls up the Options menu.

Operation using Controller

Calling up the main menu

MENU Press the button.

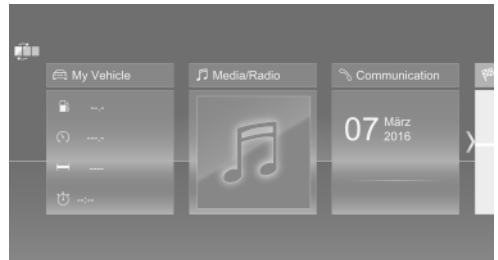

The main menu is displayed.

All iDrive functions can be called up via the main menu.

Adapting the main menu

- MENU** Press the button twice.
All menu items of the main menu are displayed.
- Select a menu item.
- To move a menu item to the desired position, tilt the Controller to the right or left.

Selecting a menu item

Highlighted menu items can be selected.

1. Turn the Controller until the desired menu item is highlighted.

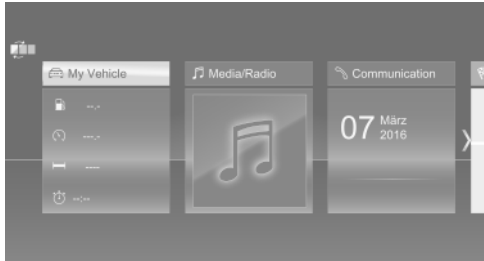

2. Press the Controller.

Menu items in the Owner's Handbook

In this Owner's Handbook, the menu items that can be selected are shown in quotation marks, for example "iDrive settings".

Switching between screens

After a menu item has been selected, for example "iDrive settings", a new screen is displayed.

- ▷ Tilt the Controller to the left.
The current screen is closed and the previous screen is displayed.
- ▷  Press the button.
The previous screen is opened again.
- ▷ Tilt the Controller to the right.
The new screen is opened.

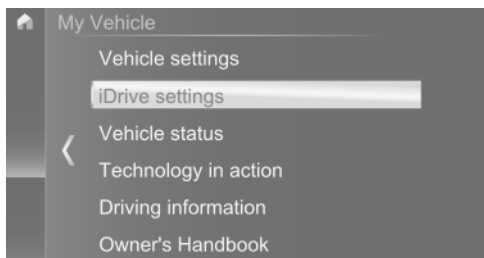

The arrow indicates that further screens can be called up.

Calling up recently used menus

The recently used menus can be displayed.



Press and hold the button.

Calling up the Options menu



Press the button.

The "Options" menu is displayed.

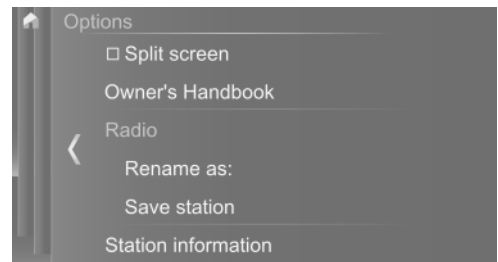

The Options menu consists of various areas:

- ▷ Screen settings, for example "Split screen".
- ▷ Operating options for the selected main menu, for example for "Media/Radio".
- ▷ If applicable, other operating options for the selected menu, for example "Save station".

Adjusting the settings

1. Select a field.

- Turn the Controller until the desired setting is displayed.

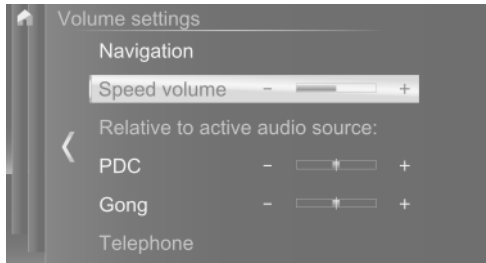

- Press the Controller.

Activating/deactivating functions

Some menu items are preceded by a checkbox. The box indicates whether the function is enabled or disabled. Selecting the menu item enables or disables the function.

- Function is enabled.
- Function is disabled.

Entering letters and numbers

General

Letters and numbers can be entered via the Controller.

The keyboard display changes automatically.

Entry

- Turn the Controller: to select letters or numbers.
- OK** : to confirm your entry.

Symbol	Function
←	Press Controller: deletes letters or digits.
←	Press and hold the Controller: deletes all letters or numbers.

Changing between upper/lower case, numbers and characters

Depending on the menu, it is possible to enter upper and lower case letters, numbers and characters.

Symbol	Function
ABC	Enter letters.
1@+	Enter numbers.
abc or ABC	Switch between upper and lower case.

Entry comparison

When entering names and addresses, the selection is gradually narrowed down and possibly supplemented with every subsequent letter that you enter.

Inputs are continuously compared with the data saved in the vehicle.

- ▷ Only letters for which data is available are offered for entry.
- ▷ Destination search: place names can be entered in all languages available in iDrive.

Operating alphabetical lists

For alphabetic lists with more than 30 entries, the letters for which entries are available, can be shown on the left side.

- Turn the Controller quickly to the left or right.
On the left, all letters are displayed for which an entry is available.
- Select the initial letter of the desired entry.
The first entry of the selected letter is displayed.

Operation by touchscreen

General

The Control Display is equipped with a touchscreen.

Touch the touchscreen with your fingers. Do not use any objects.

Calling up the main menu

🏠 Tap the symbol.

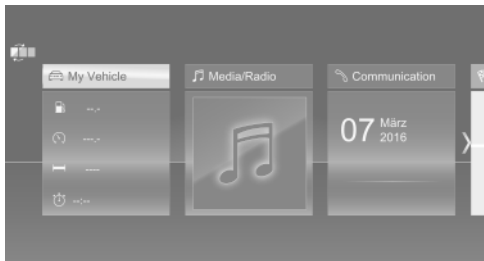

All iDrive functions can be called up via the main menu.

Selecting a menu item

Touch required menu item.

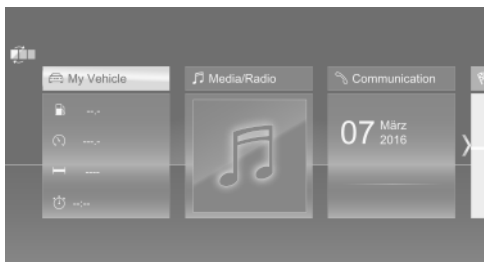

Menu items in the Owner's Handbook

In this Owner's Handbook, the menu items that can be selected are shown in quotation marks, for example "iDrive settings".

Switching between screens

After a menu item has been selected, a new screen is displayed.

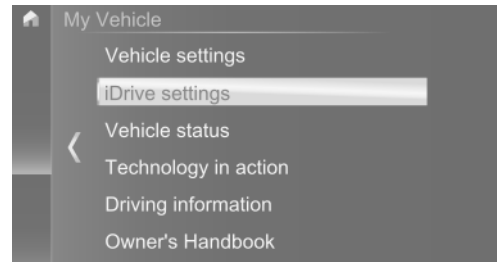

A white arrow indicates that further screens can be called up.

- ▷ Swipe to the left.
- ▷ Tap the symbol.

The new screen is opened.

Calling up recently used menus

1. 🏠 Tap the symbol.
2.  Tap the symbol.

Adjusting the settings

Settings such as volume can be made using the touchscreen.

- ▷ Move to the right or left until the required setting is displayed.
- ▷ **- +** Tap the symbol.

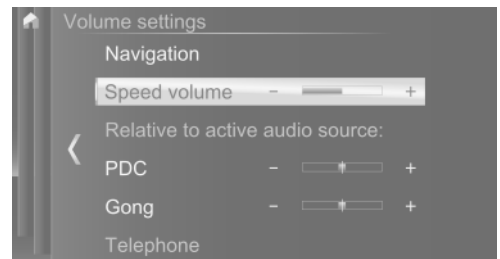

Activating/deactivating functions

Some menu items are preceded by a check-box. The box indicates whether the function is enabled or disabled. Selecting the menu item enables or disables the function.



- Function is enabled.
- Function is disabled.

Entering letters and numbers

General

Letters and numbers can be entered using the Controller or the touchscreen.

The keyboard display changes automatically.

Symbol	Function
	Tap the symbol: delete letter or number.
	Tap and hold the symbol: delete all letters or numbers.

Changing between upper/lower case, numbers and characters

Symbol	Function
ABC	Enter letters.
1@+	Enter numbers.
ABC or abc	Switch between upper and lower case.

Operation of the navigation map

The navigation map can be moved via the touchscreen.

Function	Operation
To enlarge/reduce map.	Pinch or open up your fingers.

Touchpad

General

Some of the functions of the iDrive can be operated with the touchpad of the Controller.

Selecting functions

1. "My Vehicle"
2. "iDrive settings"

3. "Touchpad"
4. Select the desired setting.
 - ▷ "Write": to enter letters and numbers.
 - ▷ "Map": to operate the map.
 - ▷ "Search fields": to write letters without selecting the list field.
 - ▷ "Audio feedback": to have the entered letters and numbers read out.

Entering letters and numbers

Entering letters requires a bit of practice to begin with. Pay attention to the following when entering:

- ▷ The system recognises upper and lower case and numbers. It may be necessary to switch between upper and lower case, numbers and characters, see page 22.
- ▷ Enter symbols as they are displayed on the Control Display.
- ▷ Always enter associated characters, such as accents or dots, so that the letter will be correctly detected. The input option depends on the language that has been set. You may need to enter special characters using the Controller.
- ▷ To delete a character, swipe on the touchpad towards the left.
- ▷ To enter a space, swipe towards the right in the middle of the touchpad.
- ▷ To enter a hyphen, swipe towards the right in the upper area of the touchpad.
- ▷ To enter an underscore, swipe towards the right in the lower area of the touchpad.

Operating map

The map of the navigation system can be moved using the touchpad.

Function	Operation
To move map.	Swipe in the appropriate direction.
To enlarge/ reduce map.	Pinch together or move apart your fingers on the touchpad.
To display menu.	Tap once.

Split screen

General

Additional information, for example information from the on-board computer, can be displayed on the right-hand side of the screen in some menus.

This information remains visible in the split screen view even if you switch to another menu.

Switching the split screen view on/off

-  Press the button.
- "Split screen"

Selecting the display

In the menus in which a splitscreen view is possible, you can select the desired display.

- Tilt the Controller to the right until the split screen is selected.
- Press the Controller.

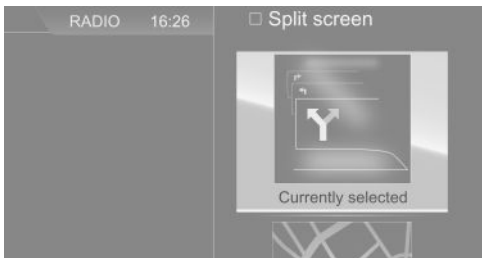

- Select the desired setting.

Defining the display selection

The display selection can be defined.

- Tilt the Controller to the right until the split screen is selected.
- Press the Controller.
- "Personalise menu"
- Select the desired setting.
- Tilt the Controller to the left.











Status information

General

The status field is located in the top area of the Control Display. Status information is displayed in the form of symbols.

Symbols in the status field

Telephone

Symbol	Meaning
	Incoming or outgoing call.
	Missed call.
	Reception level of mobile telephone network.
	Searching for network.
	No mobile telephone network available.
	Critical charge state of the mobile telephone reached.
	Data transfer not possible.
	Roaming active.
	Text message received.
	Message received.
	Reminder.

Symbol	Meaning
	Sending not possible.
	Contacts are being loaded.

Entertainment

Symbol	Meaning
	CD/DVD player.
	Music hard disc.
	Bluetooth audio.
	USB audio interface.
	Mobile telephone audio interface.
	Online Entertainment
	WLAN.
	iPod.

Other functions

Symbol	Meaning
	Check Control message.
	Sound output switched off.
	Encrypted connection not active.
	Determining the current vehicle position.
	Traffic information.

Favourites buttons

General

iDrive functions, for example radio stations, navigation destinations, telephone numbers and shortcuts to the menu, can be saved to Favourites buttons and called up directly.

The settings are saved for the currently used driver profile.

Saving a function

1. Select function via iDrive.
2.  Press and hold the desired button until a signal sounds.

Performing a function

1.  Press the button.

The function is carried out immediately. If you have selected a telephone number, for example, the connection will also be established.

Displaying the button assignment

Touch the buttons with your finger. Do not wear gloves or use objects.

The button assignment is displayed at the top edge of the screen.

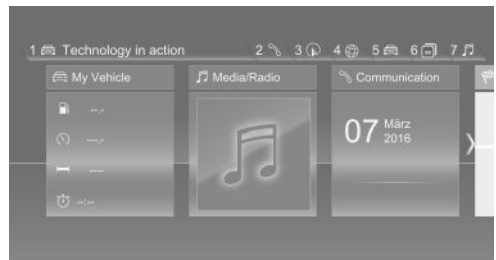

Clearing the button assignment

1. Press and hold buttons 1 and 8 simultaneously for approximately 5 seconds.
2. "OK"

Voice control system

Vehicle equipment

This chapter describes all standard, national and special equipment available for the model series. Therefore equipment which is not installed in your vehicle, for example on account of the selected optional equipment or the country specification, may also be described here. This also applies to safety-relevant functions and systems. Comply with the relevant laws and regulations when using the corresponding functions and systems.

Principle

The voice control system enables most of the functions shown in the Control Display to be operated by spoken commands. The system provides spoken announcements to assist you with input.

General

- ▷ Functions that can only be used when the vehicle is stationary can only be operated via the voice control system to a limited extent.
- ▷ The system has a special microphone on the driver's side.
- ▷ »...« Indicates commands for the voice control system in the Owner's Handbook.
- ▷ Commands, numbers and letters should be spoken fluently, with the usual emphasis and at a normal volume and speed.
- ▷ Always speak the commands in the language of the voice control system.
- ▷ When selecting the radio station, use the customary pronunciation of the station name as it is displayed on the Control Display.

»[...] Station ...«, for example, Classic Radio station.

Requirements

On the Control Display set a language that is also supported by the voice control system, so that the vehicle can identify spoken commands.

Setting the language, see page 30.

Saying voice commands

Activating the voice control system

1.  Press the button on the steering wheel.
2. Wait for the acoustic signal.
3. Say the command.

This symbol  in the instrument cluster indicates that the voice control system is active.

If no further spoken commands are possible, switch to iDrive to operate the function.

Switching off the voice control system

-  Press the button on the steering wheel or say »Cancel«.

Possible commands

General

Most of the menu items on the Control Display can be said as commands.

Commands from other menus can be spoken as well.

Some list entries, for example telephone book entries, can also be selected using the voice

control system. When doing this, list entries are to be spoken exactly as they are shown in the relevant list.

Displaying possible commands

The following is displayed in the upper area of the Control Display:

- ▷ Some of the possible commands for the current menu.
- ▷ Some possible commands from other menus.
- ▷ Voice recognition status.
- ▷  Encrypted connection unavailable.

Help with the voice control system

- ▷ To have information about the voice control system read aloud: ›General information on voice control.
- ▷ To have help on the current menu read aloud: ›Help◀.

An example: calling up sound settings

The commands for the menu items are spoken exactly as they are selected using the Controller.

1. If necessary, switch on entertainment audio output.
2.  Press the button on the steering wheel.
3. ›Media and radio◀
4. ›Sound◀

Settings

Setting the speech dialogue

You can select whether the system uses the standard dialogue or the short variant.

With the short variants of the speech dialogue, the system announcements are played in shortened form.

Via iDrive:

1. "My Vehicle"
2. "iDrive settings"
3. "Language"
4. "Voice control:"
5. Select the desired setting.

Selecting the input language

For some languages, it is possible to select which language is used for voice input.

Via iDrive:

1. "My Vehicle"
2. "iDrive settings"
3. "Language"
4. "Voice input:"
5. Select the desired setting.

Activating voice recognition via server

Voice recognition via server enables use of the dictation function and natural input of destinations and improves the quality of voice recognition. For use, data are sent to a service provider and stored locally there.

Via iDrive:

1. "My Vehicle"
2. "iDrive settings"
3. "Language"
4. "Server speech recognition"

Speaking during voice output

It is possible to answer while the voice control system is querying your previous spoken instruction. The function can be deactivated if the confirmations are frequently cancelled inadvertently, for example due to background noise or speaking.

Via iDrive:

1. "My Vehicle"
2. "iDrive settings"
3. "Language"
4. "Speaking during voice output"

Adjusting the volume

Turn the volume knob during the spoken instructions until the desired volume is obtained.

- ▷ The volume setting is retained even if you change the volume of other audio sources.
- ▷ The volume setting is saved for the currently used driver profile.

Note regarding emergency calls

The voice control system should not be used for emergency calls. Under stress, a person's speech and voice pitch can change. This could unnecessarily delay the connection of your call.

Instead, use the SOS button, see page [237](#), located near the rear-view mirror.

Operating conditions

- ▷ Doors, windows and the Glass Roof should be kept closed to avoid noise interference.
- ▷ Avoid background noises in the vehicle while you are speaking.

General settings

Vehicle equipment

This chapter describes all standard, national and special equipment available for the model series. Therefore equipment which is not installed in your vehicle, for example on account of the selected optional equipment or the country specification, may also be described here. This also applies to safety-relevant functions and systems. Comply with the relevant laws and regulations when using the corresponding functions and systems.

Language

Setting the language

Via iDrive:

1. "My Vehicle"
2. "iDrive settings"
3. "Language"
4. "Language:"
5. Select the desired setting.

The setting is saved for the currently used driver profile.

Setting the speech dialogue

Speech dialogue for the voice control system, see page [28](#).

Time

Setting the time zone

Via iDrive:

1. "My Vehicle"
2. "iDrive settings"
3. "Date and time"

4. "Time zone:"
5. Select the desired setting.

The setting is saved for the currently used driver profile.

Setting the time

Via iDrive:

1. "My Vehicle"
2. "iDrive settings"
3. "Date and time"
4. "Time:"
5. Turn the Controller until the desired hours are displayed.
6. Press the Controller.
7. Turn the Controller until the desired minutes are displayed.
8. Press the Controller.

The setting is saved for the currently used driver profile.

Setting the time format

Via iDrive:

1. "My Vehicle"
2. "iDrive settings"
3. "Date and time"
4. "Time format:"
5. Select the desired setting.

The setting is saved for the currently used driver profile.

Automatic time setting

Depending on equipment, the time, date and, if necessary, time zone are updated automatically.

Via iDrive:

1. "My Vehicle"
2. "iDrive settings"
3. "Date and time"
4. "Automatic time setting"

The setting is saved for the currently used driver profile.

Date

Setting the date

Via iDrive:

1. "My Vehicle"
2. "iDrive settings"
3. "Date and time"
4. "Date:"
5. Turn the Controller until the desired day is displayed.
6. Press the Controller.
7. Alter the setting for month and year.

The setting is saved for the currently used driver profile.

Setting the date format

Via iDrive:

1. "My Vehicle"
2. "iDrive settings"
3. "Date and time"
4. "Date format:"
5. Select the desired setting.

The setting is saved for the currently used driver profile.

Setting units of measurement

It is possible to select the units of measurement for various values, for example fuel consumption, distances and temperature.

Via iDrive:

1. "My Vehicle"
2. "iDrive settings"
3. "Units"
4. Select the desired menu item.
5. Select the desired setting.

The setting is saved for the currently used driver profile.

Activating/deactivating display of the current vehicle position

Principle

If vehicle tracking is activated, the current vehicle position can be displayed in the BMW Connected app or in the ConnectedDrive customer portal.

Activating/deactivating

Via iDrive:

1. "My Vehicle"
2. "Vehicle settings"
3. "Vehicle tracking"
4. "Vehicle tracking"

Activating/deactivating information windows

Information windows are automatically shown on the Control Display for some functions.

Some of these information windows can be activated or deactivated.

1. "My Vehicle"
2. "iDrive settings"
3. "Pop-ups"
4. Select the desired setting.

The setting is saved for the currently used driver profile.

Control Display

Brightness

Via iDrive:

1. "My Vehicle"
2. "iDrive settings"
3. "Displays"
4. "Control display"
5. "Brightness"
6. Turn the Controller until the desired brightness is obtained.
7. Press the Controller.

The setting is saved for the currently used driver profile.

Depending on the lighting conditions, the brightness adjustment may not be immediately apparent.

Screen saver

If no entries were made via iDrive, the screen saver can be displayed after a set time.

Via iDrive:

1. "My Vehicle"
2. "iDrive settings"
3. "Displays"
4. "Control display"
5. "Screensaver"
6. Select the desired setting.

The setting is saved for the currently used driver profile.

Selecting the content of the main menu

The content displayed in some menu items of the main menu can be selected.

1.  Press the button.
2. "Contents of main menu"
3. Select the desired menu and desired content.

The setting is saved for the currently used driver profile.

Messages

Principle

The menu shows all messages that arrive in the vehicle, centrally in the form of a list.

General

The following messages can be displayed:

- ▷ Traffic messages.
- ▷ Check Control messages.
- ▷ Communication messages, for example e-mail, SMS or reminders.
- ▷ Service requirement messages.

Messages are additionally displayed in the status field.

Calling up messages

Via iDrive:

1. "Notifications"
2. Select the required message.

The corresponding menu is opened, in which the message is displayed.

Deleting messages

All messages which are not Check Control messages can be deleted from the list. Check Control messages remain for as long as they are relevant.

Via iDrive:

1. "Notifications"
2. Select the required message if necessary.
3.  Press the button.
4. "Delete this notification" or "Delete all notifications"

Settings

The following settings can be performed:

- ▷ Select the applications from which messages are permitted.
- ▷ Sort the sequence of messages by date or priority.

Via iDrive:

1. "My Vehicle"
2. "iDrive settings"
3. "Notifications"
4. Select the desired setting.

Data protection

Data transfer

Principle

The vehicle offers various functions which require data to be transferred to BMW or a service provider. The transfer of data can be deactivated for some functions.

General

If data function has been deactivated for a function, then that function cannot be used.

Only perform settings with the vehicle at a standstill.

Activating/deactivating data transfer

Follow the instructions on the Control Display.

Via iDrive:

1. Switch on the ignition.
2. "My Vehicle"
3. "iDrive settings"
4. "Data privacy"
5. Select the desired setting.

Deleting personal data in the vehicle

Principle

Depending on use, the vehicle stores personal data such as saved radio stations. This personal data can be permanently deleted using iDrive.

General

Depending on the equipment installed in your vehicle, the following data can be deleted:

- ▷ Driver profile settings.
- ▷ Saved radio stations.
- ▷ Saved Favourites buttons.
- ▷ Trip and on-board computer values.
- ▷ Music hard disc.
- ▷ Navigation, for example saved destinations.
- ▷ Phone book.
- ▷ Online data, for example Favourites, cookies.
- ▷ Office data, for example voice memos.
- ▷ Login accounts.

It can take up to 15 minutes in total to delete data.

Operating requirements

Data can only be deleted with the vehicle at a standstill.

Deleting data

Follow the instructions on the Control Display.

Via iDrive:

1. Switch on the ignition.
2. "My Vehicle"
3. "iDrive settings"
4. "Data privacy"
5. "Delete personal data"
6. "Delete personal data"
7. "OK"
8. Exit and lock the vehicle.

Deletion is completed after 15 minutes.

If not all data is deleted, repeat deletion if required.

Cancelling deletion

Start the engine to cancel data deletion.

Connections

Principle

Various connection types are available for using mobile devices in the vehicle. The connection type to select depends on the mobile device and the desired function.

General

The following overview shows possible functions and the appropriate connection types for them. The extent of applications depends on the mobile device.

Function	Connection type
Telephoning using the hands-free system.	Bluetooth.
Operating telephone functions via iDrive.	
Using the smartphone Office functions.	
Playing music from the smartphone or the audio player.	Bluetooth or USB.
Operating compatible apps via iDrive.	Bluetooth or USB.
USB storage medium:	USB.
Exporting and importing driver profiles.	
Performing software updates.	
Importing and exporting stored journeys.	
Music playback.	
Playing videos from the smartphone or the USB device.	USB.
Using the vehicle Internet access.	Internet hotspot.
Operate Apple CarPlay apps via iDrive and by voice commands.	Bluetooth and WiFi.
Screen Mirroring:	WiFi.
Showing the smartphone display on the Control Display.	

The following connection types require one-off registration process with the vehicle:

- ▷ Bluetooth.
- ▷ Internet hotspot.
- ▷ Apple CarPlay.
- ▷ Screen Mirroring.

Connected devices are then automatically recognised and connected to the vehicle.

Safety note



WARNING

Operating integrated information systems and communication devices during the journey may distract you from the traffic. You could lose control of the vehicle. There is a danger of accidents. Only operate the systems or devices if permissible in the traffic situation. Stop if necessary and operate the systems or devices with the vehicle at a standstill. ◀

Compatible devices

General

Information about mobile devices compatible with the vehicle is available at www.bmw.com/bluetooth.

Malfunctions may occur when using unlisted devices or different software versions.

Viewing the vehicle identification number and software part number

When looking for compatible devices, the vehicle identification number and software part number may have to be stated. These numbers can be displayed in the vehicle.

Via iDrive:

1. "My Vehicle"
2. "iDrive settings"
3. "Mobile devices"
4. "Settings"
5. "Bluetooth information"
6. "System information"

You have the option of performing a software update, see page 41.

Bluetooth pairing

Operating requirements

- ▶ Compatible device, see page 35, with Bluetooth interface.

- ▶ The remote control is in the vehicle.
- ▶ The device is ready for operation.
- ▶ Bluetooth is activated on the device and in the vehicle, see page 35.
- ▶ If default Bluetooth settings are required on the device, for example visibility, see the user manual of the device.

Switching on Bluetooth

Via iDrive:

1. "My Vehicle"
2. "iDrive settings"
3. "Mobile devices"
4. "Settings"
5. "Bluetooth"

Activating/deactivating telephone functions

To be able to use all supported functions of a mobile telephone, it is necessary for the following functions to be activated before registering.

Via iDrive:

1. "My Vehicle"
2. "iDrive settings"
3. "Mobile devices"
4. "Settings"
5. Select the desired setting:
 - ▶ "Office"



Activate this function to transfer SMS messages, e-mails, calendar, tasks, memos and reminders to the vehicle. Transferring all data to the vehicle may incur costs.
 - ▶ "Contact pictures"

Activate the function to have contact pictures displayed.
6. Tilt the Controller to the left.

Registering the mobile device with the vehicle

Via iDrive:

1. "My Vehicle"
2. "iDrive settings"
3. "Mobile devices"
4. "Connect new device"
5. Select the functions for which the device will be used:

- ▷  "Telephone"
- ▷  "Bluetooth audio"
- ▷ "Apps"
- ▷  "Apple CarPlay"

The Bluetooth name of the vehicle is displayed in the Control Display.

6. On the mobile device, search for Bluetooth devices in the vicinity.

The Bluetooth name of the vehicle is shown on the display of the mobile device. Select the Bluetooth name of the vehicle.

7. Depending on the mobile device, either a control number is displayed, or you will have to enter the control number yourself.

- ▷ Compare the control number shown on the Control Display with the control number in the device display.

Confirm the control number in the device and on the Control Display.

- ▷ Enter the same control number on the device and via iDrive then confirm.

The device is connected and displayed in the device list, see page 40.

If the connection was not successful: Frequently Asked Questions, see page 36.

Frequently Asked Questions

All preconditions are met and all necessary steps have been carried out in the specified order. Nevertheless, the mobile device does not function as expected.

In such cases, the following explanations may provide assistance:

Why could the mobile telephone not be paired or connected?

- ▷ Too many Bluetooth devices are paired to the mobile telephone or the vehicle.

In the vehicle, delete Bluetooth connections with other devices.

Delete all known Bluetooth connections from the device list on the mobile telephone and start a new device search.

- ▷ The mobile telephone is in power-save mode or the battery is low.
Charge up the mobile telephone.
- ▷ It might be the case that only one mobile telephone can be connected to the vehicle, depending on the mobile telephone.
Unpair the connected mobile telephone from the vehicle and only register and connect one mobile telephone.

Why does the mobile telephone no longer respond?

- ▷ The applications on the mobile telephone are no longer functioning.

Switch the mobile telephone off and on again.

- ▷ Ambient temperatures too high or too low to operate the mobile telephone.

Do not subject the mobile telephone to extreme ambient conditions.

Why can telephone functions not be operated via iDrive?

- ▷ The mobile telephone may not be configured correctly, for example as a Bluetooth audio device.

Connect the mobile telephone with the telephone or additional telephone function.

Why are no phone book entries, not all entries or incomplete entries displayed?

- ▷ The transfer of the phone book entries is not yet completed.

- ▷ Under certain circumstances only the phone book entries saved in the mobile telephone or on the SIM card are transferred.
- ▷ It is possible that phone book entries with special characters cannot be displayed.
- ▷ It may not be possible to transfer contacts from social networks.
- ▷ The number of phone book entries to be saved is too high.
- ▷ The data volume of the contact is too large, for example due to saved information such as memos.
Reduce the data volume of the contact.
- ▷ A mobile telephone can only be connected as an audio source or as a telephone.
Configure the mobile telephone and connect it with the telephone or additional telephone function.

How can the telephone connection quality be improved?

- ▷ Depending on the mobile telephone, it may be possible to adjust the strength of the Bluetooth signal on the mobile telephone.
- ▷ Place the mobile telephone in the snap-in adapter or close to the centre console.
- ▷ Insert the mobile telephone in the wireless charging cradle.
- ▷ Adjust the volume of the microphone and speaker separately.

If all the points on the list have been reviewed and the desired function cannot be performed, contact the Hotline, a Service Partner of the manufacturer or another qualified Service Partner or a specialist workshop.

USB connection

General

Mobile devices with a USB port are connected to the USB interface.

- ▷ Mobile telephones.

The snap-in adapter has its own USB port that is automatically connected when an appropriate mobile telephone is inserted.

- ▷ Audio devices with a USB port, for example MP3 players.
- ▷ USB storage devices.

Common file systems are supported. Formats FAT32 and exFAT are recommended.

The following uses are possible:

- ▷ Exporting and importing of driver profiles, see page 56.
- ▷ Playback of music files via USB audio.
- ▷ Playback of video films via USB video.
- ▷ Importing of software updates, see page 41.
- ▷ Importing trips.

When connecting, bear the following in mind:

- ▷ Do not use force when inserting the plug into the USB interface.
- ▷ Use a flexible adapter cable.
- ▷ Protect the USB device from mechanical damage.
- ▷ Due to the large variety of USB devices available on the market, operation via the vehicle cannot be ensured for every device.
- ▷ Do not expose the USB devices to extreme environmental conditions, for example very high temperatures, see operating instructions of the device.
- ▷ Due to the large variety of different compression techniques, correct playback of the media stored on the USB device cannot be guaranteed in every case.
- ▷ A connected USB device is supplied with charging current via the USB interface if the device supports this.
- ▷ To ensure correct transfer of the stored data, do not charge a USB device from the socket in the vehicle when the device is also connected to the USB interface.

- ▷ Depending on how the USB device is being used, it may be necessary to perform settings on the USB device, see operating instructions of the device.

Unsuitable USB devices:

- ▷ USB hard drives.
- ▷ USB hubs.
- ▷ USB memory card reader with several inserts.
- ▷ HFS-formatted USB devices.
- ▷ Devices such as fans or lamps.

Operating requirements

Compatible device, see page 35, with USB interface.

Connecting a device

Connect the USB device to a USB interface, see page 181, using a suitable adapter cable.

The USB device is displayed in the device list, see page 40.

Internet connection

General

Up to 8 devices can be connected at the same time using the Internet hotspot.

Operating requirements

- ▷ Compatible device, see page 35, with WiFi interface.
- ▷ ConnectedDrive contract.
- ▷ Data contract with a service provider.
- ▷ WiFi activated on the device.
- ▷ Internet hotspot activated on the vehicle.
- ▷ Ignition is switched on.

Activating the Internet hotspot

Via iDrive:

1. "My Vehicle"
2. "iDrive settings"

3. "Mobile devices"
4. "Settings"
5. "Internet hotspot"

Connecting a device to the Internet hotspot

Via iDrive:

1. "My Vehicle"
2. "iDrive settings"
3. "Mobile devices"
4. "Connect new device"
5.  "Internet hotspot"

The hotspot name and hotspot code are displayed on the Control Display.

6. On the device, search for WiFi networks. Select the network name on the device.
7. Enter hotspot code on the device and connect.

A data volume must be purchased from a service provider when you first connect to the Internet via the Internet hotspot.

This data volume is used by all devices connected via the Internet hotspot.

Data volumes can be purchased via the ConnectedDrive Store.

Settings

The network name and hotspot code can be changed. In addition, the network name can be hidden to prevent it from being discovered by other devices.

Via iDrive:

1. "My Vehicle"
2. "iDrive settings"
3. "Mobile devices"
4.  Press the button.
5. ▷ "Change hotspot key"
Enter the required hotspot code.
- ▷ "Change hotspot name"

Enter required network name.

- ▷ "Hide hotspot"
Activate or deactivate the function.
- 6. Confirm the entry of the hotspot code or the network name:
OK Select the symbol.

Apple CarPlay

Principle

CarPlay makes it possible to operate certain functions of a compatible Apple iPhone by Siri voice operation and using iDrive.

Operating requirements

- ▷ Compatible iPhone, see page 35.
iPhone 5 or later with iOS 7.1 or later.
- ▷ Corresponding mobile radio contract.
- ▷ Bluetooth, WiFi and Siri voice operation are activated on the iPhone.

Switching on Bluetooth and CarPlay

Via iDrive:

1. "My Vehicle"
2. "iDrive settings"
3. "Mobile devices"
4. "Settings"
5. Select the following settings:
 - ▷ "Bluetooth"
 - ▷ "Apple CarPlay"

Registering iPhone with CarPlay

Register iPhone via Bluetooth on the vehicle, see page 36.

Select CarPlay as the function:

- ▷ "Apple CarPlay"

The iPhone is connected to the vehicle and displayed in the device list, see page 40.

Operation

For more information, see the integrated Owner's Handbook, online Owner's Handbook, BMW Driver's Guide app or, if necessary, the Owner's Handbook for Navigation, Entertainment, Communication.

Frequently Asked Questions

All preconditions are met and all necessary steps have been carried out in the specified order. Nevertheless, the mobile device does not function as expected.

In such cases, the following explanations may provide assistance:

The iPhone has already been paired with Apple CarPlay. When a new connection is established, CarPlay can no longer be selected.

- ▷ Delete the iPhone concerned from the device list.
- ▷ On the iPhone, delete the vehicle concerned from the list of saved vehicles under Bluetooth and under WiFi.
- ▷ Pair the iPhone as a new device.

If the steps listed have been carried out and the desired function still cannot be run: contact the hotline, a Service Partner of the manufacturer or another qualified Service Partner or a specialist workshop.

Managing mobile devices

General

- ▷ Following one-off registration, the devices are automatically detected and paired again when the ignition is switched on.
- ▷ The data saved on the SIM card or in the mobile telephone is transferred to the vehicle following detection.
- ▷ In some devices, certain settings may be necessary, for example authorisation, see operating instructions of the device.







Displaying device list

All devices registered or connected to the vehicle are displayed in the device list.

Via iDrive:

1. "My Vehicle"
2. "iDrive settings"
3. "Mobile devices"

A symbol indicates which function a device is used for.

Symbol	Function
	"Telephone"
	"Additional telephone"
	"Bluetooth audio"
	"Apps"
	"Internet hotspot"
	"Apple CarPlay"

Configuring the device

Functions can be activated or deactivated on a registered or connected device.

Via iDrive:

1. "My Vehicle"
2. "iDrive settings"
3. "Mobile devices"
4. Select the required device.
5. Select the desired setting.

If a function is assigned to a device, where applicable it is deactivated for a device that is already connected and that device is disconnected.

Disconnecting a device

A device's connection to the vehicle is disconnected.

The device remains registered and can be connected again, see page 40.

Via iDrive:

1. "My Vehicle"
2. "iDrive settings"
3. "Mobile devices"
4. Select the device.
5. "Disconnect device"

Connecting a device

A disconnected device can be reconnected.

Via iDrive:

1. "My Vehicle"
2. "iDrive settings"
3. "Mobile devices"
4. Select the device.
5. "Connect device"

Functions assigned to the device before disconnection are reassigned to the device upon reconnection. If applicable, these function are deactivated for a previously connected device.

Deleting a device

Via iDrive:

1. "My Vehicle"
2. "iDrive settings"
3. "Mobile devices"
4. Select the device.
5. "Delete device"

The device is disconnected and deleted from the device list.

Switching telephone and additional telephone

If two mobile telephones are paired with the vehicle, the functions of the telephone and additional telephone can be exchanged.

Via iDrive:

1. "My Vehicle"
2. "iDrive settings"

3. "Mobile devices"
4. "Settings"
5. "Swap telephone/additional tel."

Software update

General

The vehicle supports a large number of mobile devices, for example mobile telephones and MP3 players. Software updates are provided for many of the supported devices. Regular updating of the vehicle software keeps the vehicle up-to-date.

Updates and related, up-to-date information are posted on the website at www.bmw.com/update.

Displaying installed software version

The software version installed in the vehicle is displayed.

Via iDrive:

1. "My Vehicle"
2. "iDrive settings"
3. "Software update"
4. "Show current version"

If an update has already been applied, select the desired version to show additional information.

Updating software via USB

Do not attempt to update the software unless the vehicle is at a standstill.

Via iDrive:

1. Save the file for the software update onto a USB data storage medium in the main folder.
2. Connect USB data storage medium to a USB interface.
3. "My Vehicle"
4. "iDrive settings"
5. "Software update"

6. "Update software"
7. "USB"
8. "Install software"
9. "OK"
10. Wait for the update.
11. Confirm the system restart.

Updating software via BMW Teleservice

Software updates via BMW Teleservice are country-specific and may be unavailable.

The software is first transferred to the vehicle and can then be installed. The installation can be performed at a different time from that of the transfer.

It is possible to transfer the software during a journey. If you interrupt your journey, the transfer resumes automatically when you start off again. The other functions are available while the transfer is in process. The transfer requires mobile phone reception.

Do not attempt to update the software unless the vehicle is at a standstill.

Via iDrive:

1. "My Vehicle"
2. "iDrive settings"
3. "Software update"
4. "Update software"
5. "Teleservices"
6. "Load update"

The update is loaded, but not installed.

7. Install or remove the update.

- ▶ "Install software"

The loaded update is installed.

This step can also be carried out at a later stage.

- ▶ "Remove update"

The loaded update is removed.

The following steps are dispensed with.

8. "OK"
9. Wait for the update.
10. Confirm the system restart.

Restoring the software version

It is possible to restore the software to the version prior to the last update or to its factory settings.

Do not attempt to restore the software unless the vehicle is at a standstill.

Via iDrive:

1. "My Vehicle"
2. "iDrive settings"
3. "Software update"
4. "Restore software"
5. > "Previous version"
 - The previous software version is restored.
 - > "Software factory settings"
 - The first software version is resaved.
6. "Remove software"
7. "OK"
8. Wait for restore.
9. Confirm the system restart.

Integrated Owner's Handbook in the vehicle

Vehicle equipment

This chapter describes all standard, national and special equipment available for the model series. Therefore equipment which is not installed in your vehicle, for example on account of the selected optional equipment or the country specification, may also be described here. This also applies to safety-relevant functions and systems. Comply with the relevant laws and regulations when using the corresponding functions and systems.

Integrated Owner's Handbook in the vehicle

Principle

The integrated Owner's Handbook describes the specific equipment and functions present in the vehicle. The integrated Owner's Handbook can be shown in the Control Display.

Components of the integrated Owner's Handbook

The integrated Owner's Handbook consists of four parts providing different levels of information and access options.

Quick Reference

Important information is found in the quick reference for the operation of the vehicle, the operation of fundamental vehicle functions and in case of breakdown. This information can also be displayed during the journey.

Search by pictures

The search by pictures function enables you to search for information and descriptions using

pictures. This is particularly useful, for example, if you require a description of an item of equipment but do not know its name.

Keyword search

This function enables you to search for information and descriptions by entering a search term directly from the index.

Animations

The animations explain the basic functions of selected systems.

Selecting components

1.  Press the button.
2. "My Vehicle"
3. "Owner's Handbook"
4. Select the desired setting.

Scrolling within the Owner's Handbook

Turn the Controller until the next or previous contents are displayed.

Context-sensitive help - Owner's Handbook for the currently selected function

Relevant information can be displayed directly.

Calling up when using iDrive

Switch to the Options menu directly from the function on the Control Display:

1.  Press the button.
2. "Owner's Handbook"



Calling up when displaying a Check Control message

Directly from the Check Control message on the Control Display:

 "Owner's Handbook"

Switching between a function and the Owner's Handbook

You can use the Control Display to switch from a function, for example radio, to the Owner's Handbook, and then back and forth between the two displays:

1.  Press the button.
2. "Owner's Handbook"
3. Select the desired page in the Owner's Handbook.
4.  Press the button again to switch back to the last displayed function.
5.  Press the button again to switch back to the last displayed page of the Owner's Handbook.

To switch continuously between the last displayed function and the last displayed page of the Owner's Handbook, repeat steps 4 and 5. As you do so, new screens are opened.



Favourites buttons

General



The links/entry points/short cuts to the Owner's Handbook can be saved on Favourites buttons, see page 26, and called up directly.

Saving

1. Select required jump using iDrive:
 - ▷ "Quick reference"
 - ▷ "Picture search"
 - ▷ "Keyword search"
 - ▷ "Animations"

2. ... Press and hold required Favourites button for more than 2 seconds.

Executing/Performing

1. ... Press the appropriate button. Owner's Handbook is displayed directly with the selected jump.





Controls

The information in this chapter helps you to operate your vehicle confidently. All equipment designed to make your journey safer and more comfortable is described here.

Opening and closing

Vehicle equipment

This chapter describes all standard, national and special equipment available for the model series. Therefore equipment which is not installed in your vehicle, for example on account of the selected optional equipment or the country specification, may also be described here. This also applies to safety-relevant functions and systems. Comply with the relevant laws and regulations when using the corresponding functions and systems.

Remote control

General

The delivery specification includes two remote controls with integrated keys.

Each remote control contains a replaceable battery. Replacing the battery, see page 50.

The buttons' functions can be assigned depending on the equipment installed and the country specification. For settings, see page 59.

Personal settings are saved in the vehicle for each remote control. Driver profiles, see page 56.

The remote controls store servicing information. Service data in the remote control, see page 229

Safety notes

WARNING

Persons remaining in the vehicle or pets left inside can lock the doors from the inside and lock themselves in. In this case, the vehicle cannot be opened from the outside. There is a danger of injury. Carry the remote control with you so that you can open the vehicle from the outside. ◀

WARNING

If the vehicle is locked from the outside, it cannot be unlocked from the inside in some country versions.

There is a risk of injury or danger to life if persons remain in the vehicle for extended periods and are exposed to extreme temperatures as a result. Do not lock the vehicle from the outside when there is someone inside it. ◀

WARNING

Unsupervised children or animals in the vehicle can set the vehicle in motion and endanger themselves or other road users, for example by the following actions:

- ▷ Pressing the start/stop button.
- ▷ Releasing the parking brake.
- ▷ Opening and closing doors or windows.
- ▷ Engage selector lever position N.
- ▷ Operating vehicle equipment.

There is a risk of accident or injury. Do not leave children or animals unsupervised in the vehicle. When leaving the vehicle, take the remote control with you and lock the vehicle. ◀

Overview

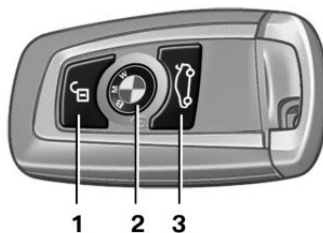

- 1 Unlocking
- 2 Locking
- 3 Opening the boot lid

Unlocking



Press the button on the remote control.

Depending on the settings, see page 59, the following access points are unlocked.

- ▷ The driver door and the fuel filler flap.
Press the button on the remote control again to unlock the other access points.
- ▷ All doors, the boot lid and the fuel filler flap.

The following functions are also carried out:

- ▷ The settings saved in the driver profile, see page 56, are applied.
- ▷ The driver's seat is set to the last seat position saved. This function must be activated in the settings, see page 59.
- ▷ The interior light is switched on, unless it was switched off manually. Switch the interior light on/off manually, see page 124.
- ▷ The exterior lights activated in the settings, see page 59, are switched on.
- ▷ Automatically folded-in exterior mirrors are folded out. This function must be activated in the settings. Exterior mirrors folded in using comfort closing must be folded out using comfort opening.
- ▷ With anti-theft system: The anti-theft system is switched off.
- ▷ The alarm system, see page 60, is switched off.

The light functions might be dependent on the ambient brightness.



Press remote control button twice in direct succession to activate comfort memory.

When a door is opened, the window is lowered further to make it easier to get in. This function must be activated in the settings, see page 59.

Comfort opening



Keep the button on the remote control pressed after unlocking.

The windows and Glass Roof are opened for as long as the button on the remote control is pressed.

Locking

1. Close the driver door.
2. Press the  button on the remote control.

Following functions are carried out:

- ▷ All doors, boot lid and fuel filler flap are locked.
- ▷ With anti-theft system: The anti-theft system is switched on. This prevents the doors from being unlocked using the locking buttons or the door openers.
- ▷ The alarm system, see page 60, is switched on.

If vehicle horn sounds twice when locking, this means engine or ignition is still switched on. In this case, switch off engine or ignition using start/stop button.

Comfort closing

Safety note



WARNING

Parts of the body can become trapped when the comfort closing feature is operating. There is a danger of injury. During comfort closing, make sure that the area of movement is kept free. ◀

Closing



Keep the button on the remote control pressed after locking.

The windows and the Glass Roof are closed for as long as the button on the remote control is pressed.

The exterior mirrors are folded in.

Switching on interior light and courtesy light

 With the vehicle locked, press the button on the remote control.

This function is not available if the interior light was switched off manually.

The light functions might be dependent on the ambient brightness.

After locking, wait 10 seconds before pressing the button again.

Boot lid

General

To prevent the remote control from being locked in, do not place the remote control in the boot.

Depending on the equipment and country version, it can be set whether the doors are also unlocked when unlocking with the remote control. Adjusting the settings, see page 59.

On some equipment versions, the doors are also unlocked each time.

Safety notes

 **WARNING**
Parts of the body can become trapped when the boot lid is operating. There is a danger of injury. When opening and closing, make sure that the area of movement of the boot lid is free. ◀

 **NOTE**
The boot lid swings rearwards and upwards when opened. There is a danger of damage to property. When opening and closing, make sure that the area of movement of the boot lid is free. ◀

Opening

 Press the button on the remote control for approximately 1 second.

Replacing the battery

1. Remove the integrated key from the remote control, see page 52.
2. Place integrated key under the battery compartment cover, arrow 1, and pry off the cover with a lever motion of the integrated key, arrow 2.

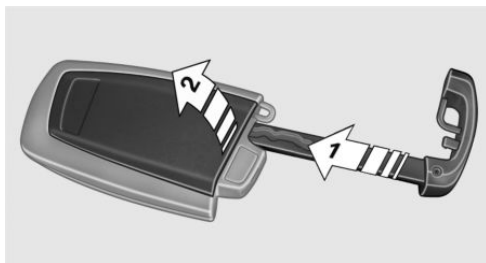

3. Use a pointed object to push the battery in the direction of the arrow and lift it out.

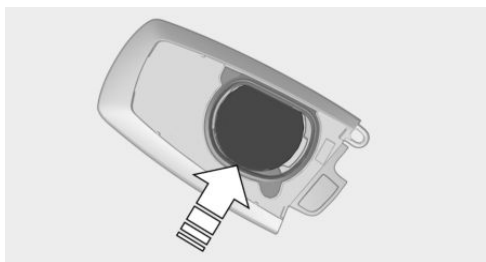

4. Insert a new type CR 2450 battery with the positive side facing upwards.
5. Press the cover back into position.
6. Push the integrated key into the remote control until it snaps into place.



Dispose of old batteries at a Service Partner of the manufacturer or another qualified Service Partner or a specialist workshop or hand them into an authorised collecting point.

Additional remote controls

Additional remote controls are available from a Service Partner of the manufacturer or another qualified Service Partner or a specialist workshop.

Loss of remote controls

A lost remote control can be blocked and replaced by a Service Partner of the manufacturer or another qualified Service Partner or a specialist workshop.

Malfunction

General

A Check Control message is shown.

It may be difficult for the vehicle to detect the remote control in some conditions, including the following:

- ▶ The battery of the remote control is discharged. Replacing the battery, see page 50.
- ▶ Disruption of the radio link by transmission masts or other equipment transmitting powerful signals.
- ▶ Shielding of the remote control by metallic objects.
Do not transport the remote control together with metallic objects.
- ▶ Disruption of the radio link by mobile telephones or other electronic devices in the immediate vicinity of the remote control.
Do not transport the remote control together with electronic devices.
- ▶ Interference with the radio link caused by the charging of mobile devices, for example a mobile phone.
- ▶ The remote control is located in the immediate vicinity of the wireless charging cradle.

Place the remote control somewhere else.

If there is a malfunction, the vehicle can be unlocked and locked from the outside with the integrated key, see page 51.

Starting the engine via special ID of the remote control

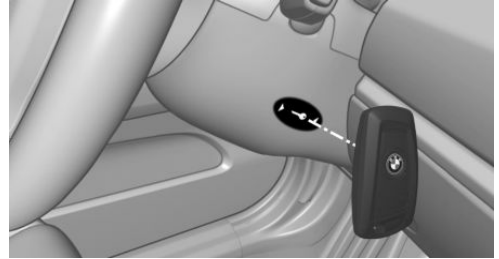

1. Hold the back of the remote control against the mark on the steering column.
2. Start the engine within 10 seconds.

If the remote control is not detected, change the position of the remote control slightly and repeat the procedure.

Integrated key

General

With the integrated key, the driver door can be unlocked and locked without the remote control.

The integrated key also fits the glove box on the front passenger side.

Use the integrated key to operate the key switch for front passenger airbags, see page 128.

Safety notes



WARNING

If the vehicle is locked from the outside, it cannot be unlocked from the inside in some country versions.

There is a risk of injury or danger to life if persons remain in the vehicle for extended periods and are exposed to extreme temperatures as a result. Do not lock the vehicle from the outside when there is someone inside it. ◀



NOTE

The door lock is firmly connected to the door. The door handle can be moved. Pulling the door handle when the integrated key is inserted can damage the paint or the integrated key. There is a danger of damage to property. Pull out the integrated key before pulling on the outer door handle. ◀

Removing

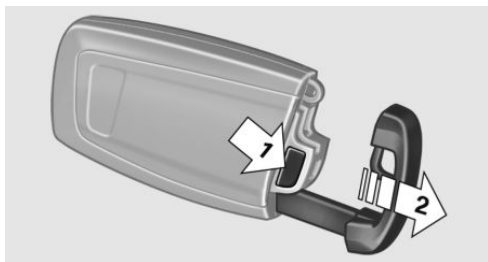

Press the button, arrow 1, and pull out the integrated key, arrow 2.

Unlocking/locking using the door lock

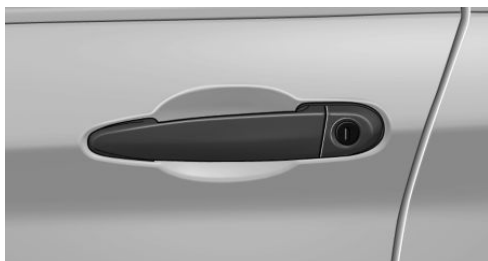

Unlock or lock the driver door using the integrated key in the door lock.

The other doors must be unlocked or locked from the inside.

Alarm system

The alarm system is not switched on if the vehicle is locked with the integrated key.

The alarm system is triggered if the vehicle is unlocked via the door lock.

To stop the alarm, unlock the vehicle with the remote control or turn on the ignition, with special ID of the remote control, see page 51, as necessary.

Central locking button

General

In the event of an accident of sufficient severity, the vehicle is automatically unlocked. The hazard warning lights and interior lights illuminate.

Overview

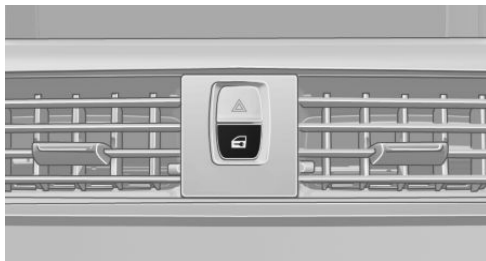

Central locking button.

Unlocking and locking

Press the button. To lock, the doors must be closed.

- ▷ The fuel filler flap remains unlocked.
- ▷ Locking does not activate anti-theft protection for the vehicle.

Opening

- ▷ Press  button to unlock doors together and then pull door opener above armrest.

- ▷ Pull twice on door opener on door to be opened: first pull unlocks door, second pull opens door. The other doors remain locked.

Comfort Access

Principle

This feature allows you to access the vehicle without having to operate the remote control. Simply having the remote control with you, for example in your trouser pocket, is sufficient. The vehicle automatically recognises the remote control when it is in the immediate vicinity or inside the vehicle.

General

Comfort Access supports the following functions:

- ▷ Unlocking and locking the vehicle.
- ▷ Comfort closing.
- ▷ Open the boot lid.
- ▷ Open boot lid contactlessly.

Operating requirements

- ▷ To lock, the remote control must be located outside the vehicle in the vicinity of the doors.
- ▷ The vehicle can only be unlocked and locked again after approximately 2 seconds.

Unlocking

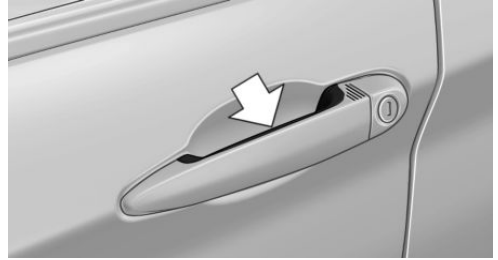

Completely grip handle of the driver or front passenger door.

This corresponds to pressing the  button on the remote control.

Locking

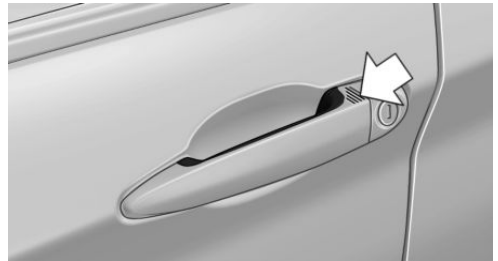

Use your finger to touch the area on the door handle of the driver or front passenger door for approximately 1 second, without gripping the door handle.

This corresponds to pressing the  button on the remote control.

Comfort closing

Safety note



WARNING

Parts of the body can become trapped when the comfort closing feature is operating. There is a danger of injury. During comfort closing, make sure that the area of movement is kept free. ◀

Closing

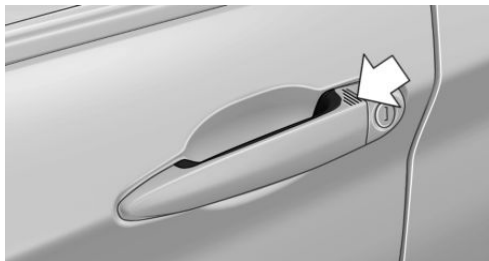

Use your finger to touch area on door handle of the driver or front passenger door and keep your finger there without gripping door handle.

Corresponds to pressing and holding the  button on the remote control.

In addition to locking, windows and Glass Roof are closed and exterior mirrors are folded in.

Opening the boot lid

General

If the boot lid is opened using Comfort Access, locked doors are not unlocked.

To prevent the remote control from being locked in, do not place the remote control in the boot.

Safety notes

WARNING

Parts of the body can become trapped when the boot lid is operating. There is a danger of injury. When opening and closing, make sure that the area of movement of the boot lid is free. ◀

NOTE

The boot lid swings rearwards and upwards when opened. There is a danger of damage to property. When opening and closing, make sure that the area of movement of the boot lid is free. ◀

Opening

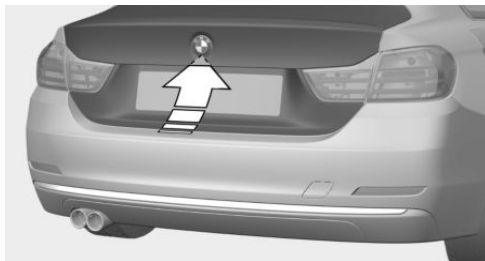

Press the button on the boot lid.

This corresponds to pressing the  button on the remote control.

Contactless opening of the boot lid

Principle

The boot lid can be opened contactlessly if you carry the remote control. Two sensors detect a foot movement forwards in the central rear area and the boot lid is opened.

General

To prevent the remote control from being locked in, do not place the remote control in the boot.

If the remote control is within the sensor range, the boot lid can be accidentally operated by an unintentional or supposedly recognised foot movement.

The sensor range extends to approximately 1.50 m, 5 ft behind the rear area.

If the boot lid is opened with a contactless method, locked doors are not unlocked.

Safety notes

WARNING

During operation without contact, there is a risk of touching vehicle parts, for example the hot exhaust system. There is a danger of injury. Make sure you are standing securely

when you perform the foot movement, and do not touch the vehicle. ◀



WARNING

Parts of the body can become trapped when the boot lid is operating. There is a danger of injury. When opening and closing, make sure that the area of movement of the boot lid is free. ◀



NOTE

The boot lid swings rearwards and upwards when opened. There is a danger of damage to property. When opening and closing, make sure that the area of movement of the boot lid is free. ◀

Correct foot movement

1. Stand in the centre behind the vehicle, approximately an arm's length away from the rear of the vehicle.
2. Move a foot in the direction of travel as far under the vehicle as possible and immediately pull it back again. With this movement, the leg must pass through the range of both sensors.

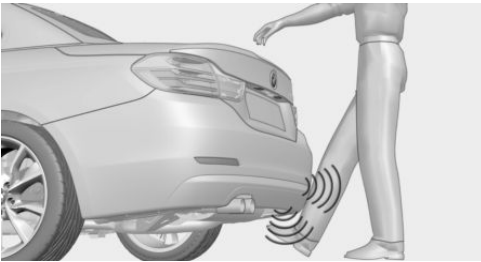

Opening

Perform the foot movement described previously.

Boot lid is opened.

The hazard warning lights flash before opening.

The opening operation can be interrupted by performing another foot movement.

Malfunction

It may be difficult for the vehicle to detect the remote control in some conditions, including the following:

- ▷ The battery of the remote control is discharged. Changing the battery, see page 50.
- ▷ Disruption of the radio link by transmission masts or other equipment transmitting powerful signals.
- ▷ Shielding of the remote control by metallic objects.
Do not transport the remote control together with metallic objects.
- ▷ Disruption of the radio link by mobile telephones or other electronic devices in the immediate vicinity of the remote control.
Do not transport the remote control together with electronic devices.

In case of a fault, unlock and lock the vehicle with the buttons on the remote control or with the integrated key, see page 51.

Boot lid

General

To prevent the remote control from being locked in, do not place the remote control in the boot.

Depending on the equipment and country version, it can be set whether the doors are also unlocked when unlocking with the remote control. Adjusting the settings, see page 59.

On some equipment versions, the doors are also unlocked each time.

Safety notes



WARNING

Parts of the body can become trapped when the boot lid is operating. There is a danger of injury. When opening and closing, make

sure that the area of movement of the boot lid is free. ◀





NOTE

The boot lid swings rearwards and upwards when opened. There is a danger of damage to property. When opening and closing, make sure that the area of movement of the boot lid is free. ◀

Opening and closing

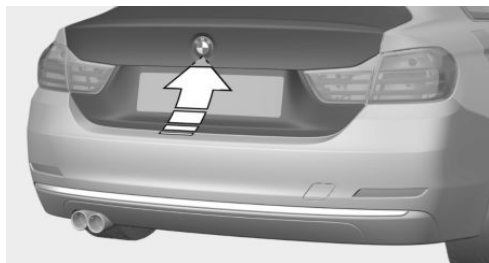
Opening from outside



- ▶ Without Comfort Access: unlock vehicle.
With Comfort Access: unlock the vehicle or have the remote control about your person.
Press the button on the boot lid.
- ▶  Press the button on the remote control for approximately 1 second.
If applicable, the doors are also unlocked.
Unlocking with remote control, see page 50.

Closing



Pull the boot lid down using the handle recess.

Boot lid emergency release



Pull the handle in the boot.
This will unlock the boot lid.

Driver profiles

Principle

Individual settings for several drivers can be saved in the driver profiles and called up again as required.

General

Three profiles are provided, in which personal vehicle settings can be saved. Each remote control is allocated to one of these driver profiles.

When the vehicle is unlocked with a remote control, the allocated driver profile is activated. All the settings saved in the driver profile are applied automatically.

If several drivers each use their own remote control, the vehicle will adapt to their personal settings when it is unlocked. These settings are also restored if the vehicle is used in the intervening period by someone with a different remote control.

Changes to settings are saved automatically in the currently used driver profile.

If a different driver profile is selected via iDrive, the settings saved there are automatically applied. The new driver profile is allocated to the remote control currently used.

A guest profile is also available which is not allocated to any remote control. It can be used to perform settings on the vehicle without changing the personal driver profiles.

Operating requirements

To ensure that the correct driver profile can be set, the system must be able to assign the detected remote control uniquely to the driver.

This is assured if the following conditions are met:

- ▶ The driver is only carrying their own remote control.
- ▶ The driver unlocks the vehicle.
- ▶ The driver enters the vehicle through the driver door.

Settings

Settings for the following systems and functions are saved in the active profile. Which settings can be saved depends on the country and equipment.

- ▶ Unlocking and locking.
- ▶ Lights.
- ▶ Air conditioning.
- ▶ Radio.
- ▶ Instrument cluster.
- ▶ Favourites buttons.
- ▶ Volumes, sound.
- ▶ Control Display.

- ▶ Navigation.
- ▶ TV.
- ▶ Park Distance Control PDC.
- ▶ Rear-view camera.
- ▶ Side View.
- ▶ Top view.
- ▶ Head-Up Display.
- ▶ M Drive: configurations.
- ▶ Driver's seat position, exterior mirror position, steering wheel position, if applicable.

The positions set via the seat memory and the last position set are saved.
- ▶ Intelligent Safety.
- ▶ Lane Change Warning.

Profile management

Selecting driver profile

Regardless of which remote control is currently being used, it is possible to call up a different driver profile. This enables the personal vehicle settings to be called up, even if the vehicle was not unlocked with the driver's own remote control.

Via iDrive:

1. "My Vehicle"
2. "Driver profiles"
3. Select driver profile.
4. "OK"
 - ▶ The settings saved in the selected driver profile are applied automatically.
 - ▶ The called up driver profile is allocated to the currently used remote control.
 - ▶ If the driver profile has already been allocated to another remote control, this driver profile applies to both remote controls.

Using a guest profile

With the guest profile, individual settings can be performed that are not saved in any of the three driver profiles.

Via iDrive:

1. "My Vehicle"
2. "Driver profiles"
3. "Drive off (guest)"
4. "OK"

The guest profile cannot be renamed. It is not allocated to the currently used remote control.

Renaming the driver profile

To avoid mixing up the driver profiles, it is possible to assign a personal name to the currently used driver profile.

Via iDrive:

1. "My Vehicle"
2. "Driver profiles"
3. Select driver profile.
 The driver profile marked with this symbol can be renamed.
4. "Change driver profile name"
5. Enter a profile name.
6. **OK** Select the symbol.

Resetting the driver profile

The settings of the driver profile currently in use are reset to factory settings.

Via iDrive:

1. "My Vehicle"
2. "Driver profiles"
3. Select driver profile.
 The driver profile marked with this symbol can be reset.
4. "Reset driver profile"
5. "OK"

Exporting driver profile

Most of the settings of the currently used driver profile can be exported.

Exporting can be useful for backing up and calling up personal settings, for example before taking the vehicle into a workshop. Once backed up, the driver profiles can be taken into a different vehicle.

Via iDrive:

1. "My Vehicle"
2. "Driver profiles"
3. Select driver profile.
 The driver profile marked with this symbol can be exported.
4. "Export driver profile"
5. Select a medium for exporting the driver profile.
 - ▷ "USB device"
If necessary, select the USB storage medium, see page 37.
 - ▷ Online.

Importing driver profile

The existing settings of the currently used driver profile are overwritten by the settings of the imported driver profile.

Via iDrive:

1. "My Vehicle"
2. "Driver profiles"
3. Select the driver profile to be overwritten.
 The driver profile marked with this symbol can be overwritten.
4. "Import driver profile"
5. Select a medium for importing the driver profile.
 - ▷ USB storage medium: "USB device"
If necessary, select the USB storage medium.

- ▶ Online.

6. Select the driver profile to be imported.

Displaying driver profiles when starting

The driver profiles can be shown every time the vehicle is started so that the desired profile to be selected.

Via iDrive:

1. "My Vehicle"
2. "Driver profiles"
3. "Show driver profiles at start"

System limits

It is not always possible to assign a remote control uniquely to a driver. This may be the case in the following scenarios:

- ▶ The front passenger unlocks the vehicle with their remote control, but another person drives.
- ▶ The driver unlocks the vehicle using Comfort Access and is carrying a number of remote controls.
- ▶ If there is a change of driver without the vehicle being locked and unlocked.
- ▶ If a number of remote controls are located in the area outside of the vehicle.

Settings

General



Various settings are possible for opening and closing, depending on the equipment and country variant.

These settings are saved for the currently used driver profile, see page 56.

Unlocking

Doors

Via iDrive:

1. "My Vehicle"
2. "Vehicle settings"
3. "Doors/Key"
4.  "Driver's door" or  "All doors"
5. Select the desired setting:
 - ▶ "Driver's door only"

Only the driver door and fuel filler flap are unlocked. Pressing again unlocks the entire vehicle.
 - ▶ "All doors"

The entire vehicle is unlocked.
 - ▶ "Comfort entry"



The entire vehicle is unlocked.

Pressing the button on the remote control twice in direct succession causes the window to be lowered further when the door is subsequently opened.

Boot lid

Depending on the equipment and country specifications, these settings may not be available.

Via iDrive:

1. "My Vehicle"
2. "Vehicle settings"
3. "Doors/Key"
4.  "Tailgate" or  "Tailgate and door(s)"
5. Select the desired setting:
 - ▶ "Tailgate"

Boot lid is opened.
 - ▶ "Tailgate and door(s)"

Boot lid is opened and doors are unlocked.

Setting the last seat and mirror position

Via iDrive:

1. "My Vehicle"
2. "Driver profiles"
3. Select driver profile.
 -  The setting can be made for the driver profile marked with this symbol.
4. "Last seat position automatic"

When the vehicle is unlocked, the driver's seat and exterior mirrors are adjusted to their last set positions.

The last position setting is independent of the positions saved via the seat memory.

Acknowledgement signals of the vehicle

Via iDrive:

1. "My Vehicle"
2. "Vehicle settings"
3. "Doors/Key"
4. "Flash for lock/unlock"
 - Unlocking is acknowledged by flashing twice, locking by flashing once.

Automatic locking

Via iDrive:

1. "My Vehicle"
2. "Vehicle settings"
3. "Doors/Key"
4. Select the desired setting:
 - ▷ "Relock automatically"
 - The vehicle is automatically locked again after a short while if no door is opened after unlocking.
 - ▷ "Lock after pulling away"
 - On driving off, the vehicle is locked automatically.

Alarm system

General

The alarm system responds to the following changes when the vehicle is locked:

- ▷ Unauthorised opening of a door, the bonnet or the boot lid.
- ▷ There are movements inside the vehicle.
- ▷ The vehicle's incline changes, for instance if an attempt is made to jack it up and steal the wheels or to raise it prior to towing away.
- ▷ There is an interruption in the power supply from the battery.

The alarm system indicates these changes visually and audibly:

- ▷ Audible alarm.
 - Depending on local regulations, the acoustic alarm may be suppressed.
- ▷ Activation of the hazard warning lights.

Switching on/off

The alarm system is switched on/off at the same time as the vehicle is unlocked and locked via the remote control or Comfort Access.

Opening the doors when the alarm system is switched on

The alarm system is triggered on opening a door if the door has been unlocked using the integrated key in the door lock.

Switching off the alarm, see page 61.

Opening the boot lid with the alarm system switched on

The boot lid can be opened even with the alarm system switched on.

On closing the boot lid, it is locked again and monitored, as long as the doors are locked. The hazard warning lights flash once.

Indicator lamp on the rear-view mirror

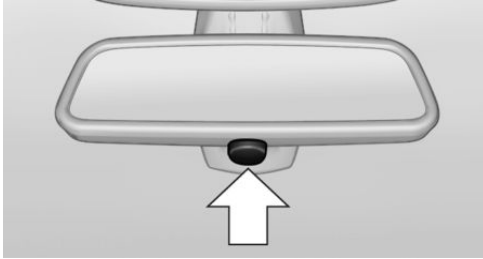

- ▶ Indicator lamp flashes every 2 seconds:
The alarm system is switched on.
- ▶ Indicator lamp flashes for approximately 10 seconds before it flashes every 2 seconds:
The interior movement detector and tilt alarm sensor are not active because doors, bonnet or boot lid are not closed correctly. Correctly closed access points are secured.
If the open access points are then closed, the interior protection and tilt alarm sensor are switched on.
- ▶ The indicator lamp extinguishes after the vehicle has been unlocked:
No attempt has been made to tamper with the vehicle.
- ▶ The indicator lamp flashes after unlocking until the ignition is switched on, but for no longer than approximately 5 minutes:
The alarm has been triggered.

Tilt alarm sensor

The incline of the vehicle is monitored. The alarm system responds, for example, when there is an attempt to steal a wheel or when towing away.

Interior movement detector

To ensure perfect functioning, the windows and Glass Roof must be closed.

Avoiding false alarms

General

The tilt alarm sensor and the interior movement detector may trigger an alarm without any unauthorised activity taking place.

Possible situations for an unwanted alarm:

- ▶ In washing bays or car washes.
- ▶ In two-level garages.
- ▶ During transport via motorail, car ferry or trailer.
- ▶ When there are animals in the vehicle.

The tilt alarm sensor and interior protection can be switched off for such situations.

Switching off the tilt alarm sensor and interior movement detector



Press the button on the remote control again within 10 seconds, as soon as the vehicle is locked.

The indicator lamp illuminates for approximately 2 seconds and then flashes again.

The tilt alarm sensor and the interior movement detector are switched off until the next time the vehicle is locked.

Switching off the alarm

- ▶ Unlock the vehicle with the remote control or switch on the ignition, if necessary using the special ID of the remote control, see page 51.
- ▶ With Comfort Access:
Fully grasp the door handle on either the driver door or the front passenger door while carrying the remote control.

Power windows

Safety note

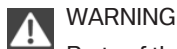

WARNING

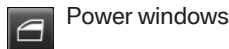

Parts of the body can become trapped when the windows are operating. There is a danger of injury or damage to property. When opening and closing, make sure that the area of movement of the windows is kept clear ◀

Overview



Power windows

Opening

- ▷  Push the switch as far as the resistance point.
The window opens as long as the switch is held.
- ▷  Push the switch past the resistance point.
The window is opened automatically. The movement is stopped by pressing the switch again.

Comfort opening using the remote control, see page 49.

Closing

- ▷  Pull the switch as far as the resistance point.

The window closes as long as the switch is held.

- ▷  Pull the switch past the resistance point.

The window closes automatically when the door is closed. Pulling the switch again stops the movement.

Comfort closing using the remote control, see page 49.

Closing using Comfort Access, see page 53.

After switching off the ignition

Windows can still be operated:

- ▷ For some time with radio ready state switched on.
- ▷ For approximately 1 minute with the ignition switched off.

Anti-trap mechanism

General

If the closing force exceeds a certain value when a window is closing, the closing operation is interrupted.

The window is opened slightly.

Safety note



WARNING

Accessories on the windows, for example aerials, can impair the anti-trap mechanism. There is a danger of injury. Do not attach any accessories in the area of movement of the windows. ◀

Closing without the anti-trap mechanism

If an external danger or ice does not allow you to close the windows normally, proceed as follows:

1.  Pull the switch past the resistance point and hold it there.

The window is closed with a restricted anti-trap mechanism. If the closing force exceeds a certain value, the closing operation is interrupted.

-  Pull the switch past the resistance point again within approximately 4 seconds and hold it there.

The window is closed without the anti-trap mechanism.

Roller sunblinds

Roller sunblind for rear window

General

If the roller sunblinds for the rear window can no longer be moved after a number of operations in immediate succession, the system is blocked for a limited time to prevent overheating. Allow the system to cool down.

The roller sunblind for the rear window cannot be operated in low interior temperatures.

Retracting or extending the roller sunblind for rear window



Press the button.

Glass Roof, electrical

General

The Glass Roof and the sun blind can be operated separately or together with the same switch.

Safety note



WARNING

Operation of the Glass Roof can lead to parts of the body becoming trapped. There is a danger of injury. When opening and closing,

make sure that the area of movement of the Glass Roof is free. ◀

Overview



Raising the Glass Roof

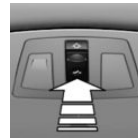

Push the switch briefly upward.

- ▶ The closed Glass Roof is raised.
- ▶ The opened Glass Roof closes to the raised position. The sun blind does not move.

Opening/closing Glass Roof and sun blind

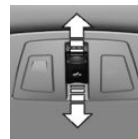

- ▶ Push and hold the switch in the desired direction as far as the resistance point.

The Glass Roof and sun blind open jointly as long as the switch is held.

The Glass Roof closes as long as the switch is held. The sun blind can be closed by hand.

- ▶ Push the switch beyond the resistance point in the desired direction.

The Glass Roof and the sun blind are opened automatically.

The Glass Roof is closed automatically. The sun blind can be closed by hand.

Movement is stopped by pressing switch upwards.

Comfort opening using the remote control, see page 49.

Comfort closing using the remote control, see page 49.

Closing using Comfort Access, see page 53.

Comfort position

If the Glass Roof is not fully opened by automatic function, this means comfort position has been reached. This position minimises wind noise in the interior.

You can continue the movement by subsequently pressing the switch.

After switching off the ignition

The Glass Roof can still be opened or closed for approximately 1 minute after the ignition has been switched off.

Anti-trap mechanism

General

If the closing force exceeds a certain value when closing the Glass Roof, the closing operation is interrupted once the roof reaches the half-open position, or it is stopped when closing from the raised position. Glass Roof is opened slightly.

Closing without anti-trap mechanism from open position

In the event of danger from the outside, proceed as follows:

1. Slide the switch forwards beyond the resistance point and hold it there.

The Glass Roof is closed with a restricted anti-trap mechanism. If the closing force

exceeds a certain value, the closing operation is interrupted.

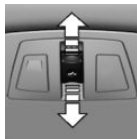

2. Press the switch forwards once again beyond the resistance point and hold until the Glass Roof closes without the anti-trap mechanism. Ensure that the closing area is clear.

Closing without anti-trap mechanism from raised position

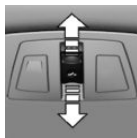

If there is a danger from the outside slide the switch forwards beyond the resistance point and hold it there.

The Glass Roof is closed without the anti-trap mechanism.

Initialising after power failure

General

The Glass Roof functions may be restricted after a power cut during the opening or closing operation.

The system can be initialised under the following conditions.

- ▶ The vehicle is parked in a horizontal position.
- ▶ The engine is running.
- ▶ The outside temperature is above 5 °C/41 °F.

During the initialisation, the Glass Roof closes without the anti-trap mechanism.

Ensure that the closing area is clear.

Initialising the system



Press the switch upwards and hold until the initialisation is complete:

Initialisation begins within 15 seconds and is complete

when the Glass Roof is fully closed.

Adjusting

Vehicle equipment

This chapter describes all standard, national and special equipment available for the model series. Therefore equipment which is not installed in your vehicle, for example on account of the selected optional equipment or the country specification, may also be described here. This also applies to safety-relevant functions and systems. Comply with the relevant laws and regulations when using the corresponding functions and systems.

Safe seating position

A sitting position that suitably reflects the requirements of the occupants is essential for relaxed driving with minimum fatigue.

In an accident, the correct seat position plays an important role. For safe driving, additionally note the following chapters:

- ▷ Seats, see page 66.
- ▷ Seat belts, see page 70.
- ▷ Head restraints, see page 72.
- ▷ Airbags, see page 126.

Seats

Safety notes

! **WARNING**
Adjusting the seat during a journey could cause the seat to move unexpectedly. You could lose control of the vehicle. There is a danger of accidents. Only adjust the seat on the driver's side when at a standstill. ◀

! **WARNING**

If the seat backrest is angled back too far, the protective effect of the seat belt will no longer be guaranteed. There is a danger of slipping under the seat belt in the event of an accident. There is a danger of injury or even death. Adjust the seat before starting the journey. Adjust the seat backrest to the most upright position possible, and do not change it during the journey. ◀

! **WARNING**

Risk of entrapment when moving the seats. There is a danger of injury or damage to property. Before performing the setting, make sure that the movement area of the seat is clear. ◀

Manually adjustable seats

Overview

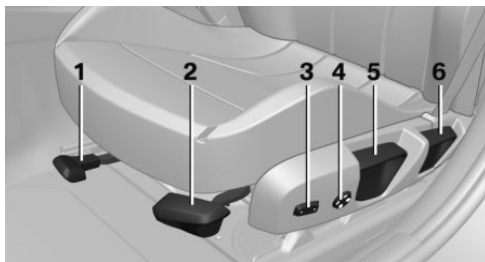

- 1 Forward/back
- 2 Seat angle
- 3 Backrest width
- 4 Lumbar support
- 5 Height
- 6 Backrest angle

Forward/back

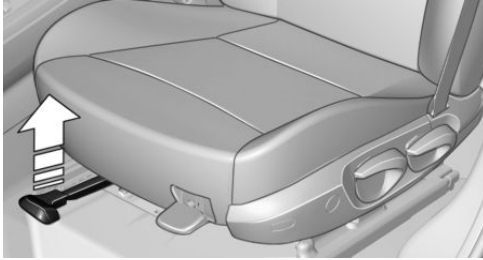

Pull the lever and slide the seat in the desired direction.

After releasing the lever, move the seat gently forward or back to make sure it engages properly.

Seat angle

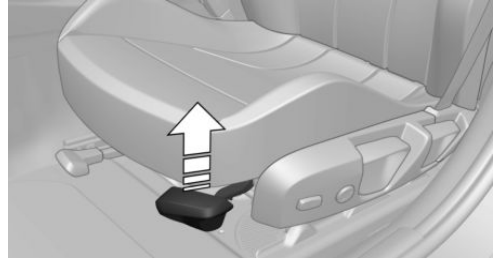

Pull the lever and move the seat until the desired angle is reached. After releasing the lever, sit on and get up out of the seat to make sure it engages properly.

Height

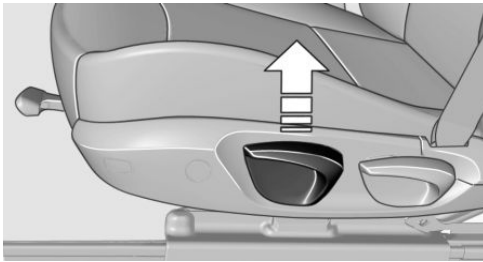

Pull the lever and add or remove pressure on the seat as required.

Backrest angle



Pull the lever and add or remove pressure on the backrest as required.

Electrically adjustable seats

General

The driver's seat adjustment is saved for the currently used profile. When the vehicle is unlocked using the remote control, this position is called up automatically if the function for this has been activated, see page 60.

The current seat position can be saved with the memory function, see page 73.

Overview

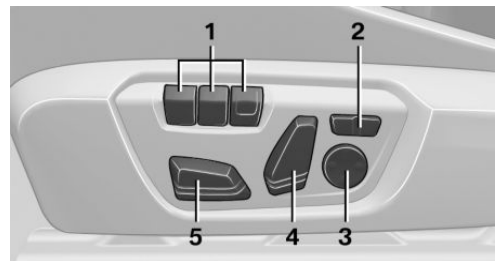

- 1 Memory function
- 2 Backrest width
- 3 Lumbar support
- 4 Backrest angle
- 5 Forward/back, height, seat angle

Forward/back

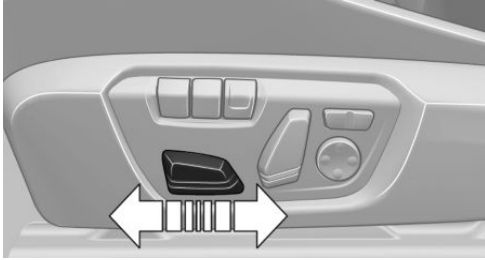

Press the switch forwards or backwards.

Backrest angle

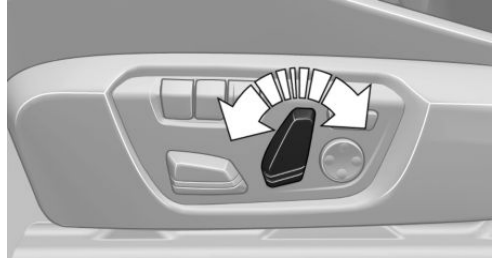

Tip the switch forwards or backwards.

Height

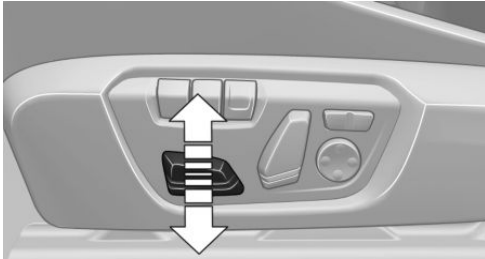

Press the switch up or down.

Lumbar support

The curvature of the backrest can be changed in such a way that the lumbar region, the lordosis, is supported. The upper edge of the pelvis and the spinal column are supported to encourage an upright posture.



- ▷ Press the button at the front/rear:
The curvature is increased/decreased.
- ▷ Press the button at the top/bottom:
The curvature is shifted upwards/downwards.

Seat angle

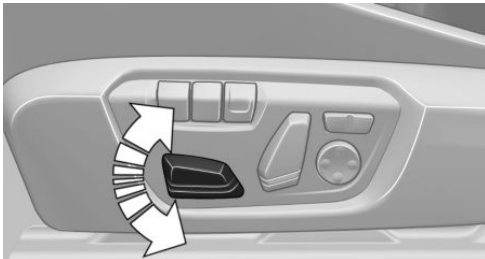

Tilt the switch up or down.

Backrest width

General

To change the width of the backrest, the side cushions of the backrest can be adjusted.

Adjusting



- ▷ Press the button at the front:
Backrest width is reduced.
- ▷ Press the button at the rear:
Backrest width is increased.

Seat heating, front

Overview



Seat heating

Switching on



Press the button once for each temperature level.

Maximum temperature is indicated by three LEDs.

If the journey is continued within about 15 minutes after a temporary stop, the seat heating is automatically activated with the last temperature set.

Switching off



Press and hold the button until the LEDs are extinguished.

Entering in the back

Safety notes



WARNING

Risk of entrapment when moving the seats. There is a danger of injury or damage to property. Before performing the setting, make sure that the movement area of the seat is clear. ◀



WARNING

The backrest can unexpectedly move during the journey when it is unlocked. You could lose control of the vehicle. There is a danger of injury. Fold back and lock the backrests before every journey. ◀

Manual longitudinal adjustment

Comfort entry

The comfort entry contains a memory function for the longitudinal and backrest adjustment.

1. Pull the lever until it stops.

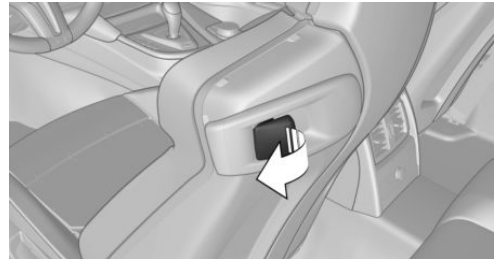

2. Fold the backrest forwards.
3. Slide the seat forwards.

Original position

1. Push seat back to the starting position.
2. Fold back backrest to lock the seat.



Electric longitudinal adjustment

Comfort entry

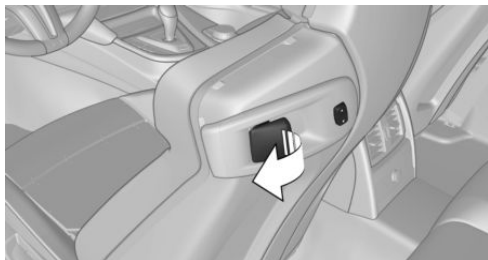

The comfort entry contains a memory function for the longitudinal and backrest adjustment.

1. Pull the lever until it stops.



2. Fold the backrest forwards.
3. Changing the entrance area:
 - ▶  Press and hold down the button until the seat has moved into the desired position. Releasing stops the movement.
 - ▶  Press the button briefly. Seat automatically moves into the end position. Pressing the button again stops the movement.

Original position

1. Move seat in original position:
 - ▶  Hold down the button until the seat is moved to its original position. Releasing stops the movement.
 - ▶  Press the button briefly. The seat moves into its original position. Pressing the button again stops the movement.
2. Fold back backrest.

Seat belts

Number of seat belts and belt buckles

For the safety of the vehicle occupants, the vehicle is equipped with four seat belts. However, they can only provide effective protection when worn correctly.

General

Before every journey, make sure that all occupants have fastened their seat belts. The air-bags are a complementary safety feature and not a substitute for the seat belts.

The belt anchorage is suitable for adults of any stature if the seat is adjusted correctly.

Safety notes

WARNING

Never restrain more than one person with each seat belt, otherwise the protective effect of the seat belt is no longer guaranteed. There is a danger of injury or even death. Only restrain one person with each seat belt. Do not allow infants and children to travel on the lap of another occupant. Instead, secure the infant or child in a child restraint system intended for this purpose. ◀

WARNING

The protective effect of the seat belts can be restricted or may even fail completely if the seat belts are worn incorrectly. If a seat belt is not worn correctly, additional injuries can be caused, for example in the event of an accident or braking and evasive manoeuvres. There is a danger of injury or even death. Make sure that all vehicle occupants have fastened their seat belts correctly. ◀

WARNING

Seat belts are designed to bear upon the body's skeleton and should be worn low across the front of the pelvis, or lie against pelvis, chest and shoulders, as applicable. Do not

route the lap section of the belt across the abdomen.

Do not modify seat belts, belt buckles, belt tensioners, belt retractors and belt anchor points and ensure that they are kept clean. A slack belt will greatly reduce the protection afforded to the wearer.

Do not allow the seat belt webbing to come into contact with polishes, oils and chemicals and particularly battery acid. It may be safely cleaned with mild soap and water. The seat belt strap should be replaced if webbing becomes frayed, contaminated or damaged. Seat belts should not be worn with seat belt straps twisted. Each seat belt assembly must only be used by one occupant; it is illegal to carry an infant or a child on the occupant's lap.

It is essential to replace the entire assembly after it has been worn in a severe impact even if damage to the assembly is not obvious. ◀



WARNING

No modifications or additions should be made by the user that will either prevent the seat belt adjusting devices from operating to remove slack, or prevent the seat belt assembly from being adjusted to remove slack. ◀



WARNING

The protective effect of the seat belts may be restricted or nullified in the following situations:

- ▶ The seat belts or belt buckles are damaged, dirty or have been modified in another way.
- ▶ Belt tensioners or belt retractors have been modified.

Seat belts can be damaged in an accident without the damage necessarily being apparent. There is a danger of injury or even death. Do not modify seat belts, belt buckles, belt tensioners, belt retractors and belt anchor points; also, keep them clean. After an accident, have the seat belts inspected at a Service Partner of the manufacturer or another

qualified Service Partner or a specialist workshop. ◀

Correct seat belt use

- ▶ Place the seat belt tightly over the pelvis and shoulder, close to the body and without twisting.
- ▶ Make sure that the seat belt is positioned low at the hip in the area of the pelvis. The seat belt must not press on the abdomen.
- ▶ The seat belt must not be rubbed on sharp edges, be routed over solid or breakable objects or be trapped.
- ▶ Avoid bulky clothing.
- ▶ Keep the seat belt taut by occasionally pulling upwards on the upper section.

Adjustment for automatic retracting seat belts

- ▶ Pull the seat belt tongue diagonally across the body and push it into the belt buckle until it audibly engages into place.
- ▶ It is important to adjust the belt length correctly. To adjust the lap belt and check whether the belt tongue has engaged correctly in the buckle, pull upwards on the shoulder section of the belt until the lap belt fits tightly.
- ▶ The diagonal shoulder strap adjusts automatically to allow freedom of movement.
- ▶ To release the seat belt, press the button on the buckle.

Fastening the seat belt

1. When fastening the seat belt, guide the seat belt slowly from the bracket.

2. Insert the seat belt tongue in the belt buckle. The seat belt buckle must be heard to engage.

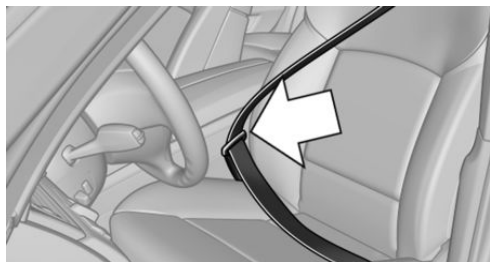

If the seat belt is fastened, the seat belt strap is automatically fastened once when driving off.

Unfastening the seat belt

1. Hold the seat belt firmly.
2. Press the red button on the belt buckle.
3. Guide the seat belt back up to the reel mechanism.

Seat belt reminder for driver and front seat passenger seat

General

The seat belt reminder is activated when the seat belt on the driver's side is not fastened.

For some country versions, the seat belt reminder is also active if the front passenger seat belt is not fastened and heavy objects are on the front passenger seat.

Display



A Check Control message is shown. Check whether the seat belt has been fastened correctly.

Seat belt reminder for rear seats



The indicator lamp in the instrument cluster is illuminated after the engine starts.

- ▷ Green: seat belt fastened on the corresponding rear seat.
- ▷ Red: seat belt not fastened on the corresponding rear seat.

The seat belt reminder will also be activated if a rear seat belt is unfastened during the journey.

Belt holder

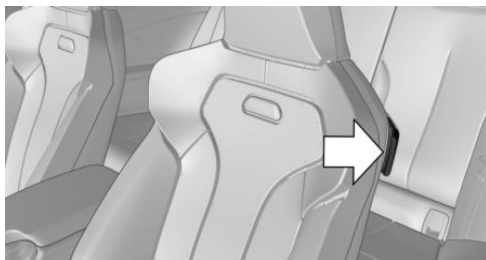

Place the seat belt in the belt holder to make it easier to put on the belt when the seat is moved forwards.

Safety function

In critical driving situations, for example full braking, the front seat belts are tensioned automatically.

If the situation passes without an accident, the belt tension is loosened again.

If the belt tension does not loosen automatically, stop the vehicle and unfasten the seat belt using the red button on the buckle. Fasten the seat belt again before continuing your journey.

Head restraints

Safety notes



WARNING

If the head restraints are removed or incorrectly adjusted, they cannot provide protection as intended and head and neck injuries may result. There is a danger of injury.

- ▷ Before a journey, fit the removed head restraints on all occupied seats.
- ▷ Adjust the head restraint so its centre supports the back of the head at as close to eye level as possible.
- ▷ Adjust the spacing so that the head restraint is as close as possible to the back of the head. If necessary, adjust the spacing using the incline of the seat backrest. ◀



WARNING

Objects on the head restraint reduce the protective effect in the head and neck area. There is a danger of injury.

- ▷ Do not fit any covers on the seats or head restraints.
- ▷ Do not hang objects such as coat hangers directly on the head restraint.
- ▷ Only use accessories that have been classified as safe for attaching to the head restraint.
- ▷ Do not use any accessories, for example cushions, during the journey. ◀

Distance

The spacing is adjusted to the back of the head using the incline of the seat backrest.

Adjust the spacing so that the head restraint is as close as possible to the back of the head.

Adjusting the height

The head restraints can be adjusted in height.

Removing

The head restraints cannot be removed.

Memory function

Principle

With the memory function, the following settings can be saved and called up if required:

- ▷ Seat position.

- ▷ Exterior mirror position.
- ▷ Height of the Head-Up Display.

General

For each driver profile, see page 56, two memory slots can be assigned with different settings.

Depending on the equipment, the following settings are not saved:

- ▷ Backrest width.
- ▷ Lumbar support.

Safety notes



WARNING

Using the memory function while driving may cause the seat to move unexpectedly. You could lose control of the vehicle. There is a danger of accidents. Only call up the memory function when the vehicle is at standstill. ◀



WARNING

Risk of entrapment when moving the seats. There is a danger of injury or damage to property. Before performing the setting, make sure that the movement area of the seat is clear. ◀

Overview



Saving

1. Switch on the ignition.
2. Set the desired position.

3.  Press the button. LED in button is illuminated.
4. Press the desired button 1 or 2 while the LED is lit. LED is extinguished.

 If the button was pressed inadvertently:

Press the button again.

LED is extinguished.

Recalling

The saved position is called up automatically.

Press the desired button 1 or 2.

The operation is halted when you press a seat adjustment switch or one of the memory buttons.

Adjusting the seat position on the driver's side is interrupted after a short time during the journey.

Calling up has been disabled

Calling up the saved seat positions is disabled after a short while to prevent the battery from being discharged.

To reactivate calling up:

- ▷ Open and close a door or the boot lid.
- ▷ Press a button on the remote control.
- ▷ Press the start/stop button.

Mirrors

Exterior mirrors

General

The mirror setting is saved for the currently used driver profile. When the vehicle is unlocked using the remote control, this position is called up automatically if the function for this has been activated, see page 60.

The current exterior mirror position can be saved with the memory function, see page 73.

Safety note



WARNING

Objects reflected in the mirror are closer than they appear. The distance to road users behind the vehicle could be incorrectly estimated, for example when changing lane. There is a danger of accidents. Look over your shoulder to estimate the distance from the following traffic. ◀

Overview



- 1 Adjusting
- 2 Selecting a mirror, automatic parking function
- 3 Folding in and out

Selecting a mirror



To switch to the other mirror:
Push the switch.

Electrical adjustment



Press the button.

The mirror moves according to the button movement.

Malfunction

In the event of an electrical fault, press the edges of the mirror glass to adjust the mirror.

Folding in and out



NOTE

Due to the vehicle's width, it could sustain damage in car washes. There is a danger of damage to property. Before washing, fold the mirrors in manually or with the button. ◀



Press the button.

Folding in is possible up to a speed of approx. 20 km/h, 15 mph.

Folding the mirrors in and out is useful in the following situations:

- ▷ In car washes.
- ▷ In narrow streets.

Folded-in mirrors automatically fold out when the vehicle reaches a speed of approximately 40 km/h, approximately 25 mph.

Automatic heating

Both exterior mirrors are automatically heated with the engine running.

Automatically dimming

The exterior mirror on the driver's side is automatically dimmed. Photocells in the rear-view mirror are used for control.

Automatic parking function, exterior mirror

Principle

When reverse gear is engaged, the mirror glass on front passenger side is tilted downwards. This improves the view of the kerb or other obstacles near the ground, for example when parking.

Activating

1.  Push the switch to the driver's mirror position.
2. Engage selector lever position R.

Deactivating



Push switch to the front passenger's mirror position.

Rear-view mirror, automatic-dim

Overview

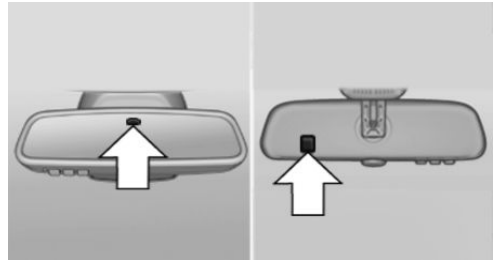

The function is controlled by photocells:

- ▷ In the mirror glass.
- ▷ On the back of the mirror.

Operating requirements

- ▷ Keep the photocells clean.
- ▷ Do not obstruct the zone between the rear-view mirror and the windscreen.

Steering wheel

Safety note



WARNING

Adjusting the steering wheel while driving may cause the steering wheel to move unexpectedly. You could lose control of the vehicle. There is a danger of accidents. Only adjust the steering wheel when the vehicle is at a standstill. ◀

Electric steering wheel lock

With manual gearbox: the steering wheel locks automatically when the driver door is opened.

Switch on the ignition to unlock.

**WARNING**

If steering wheel lock is activated, the vehicle cannot be steered. There is a danger of accidents. Switch on the ignition prior to moving the vehicle. ◀

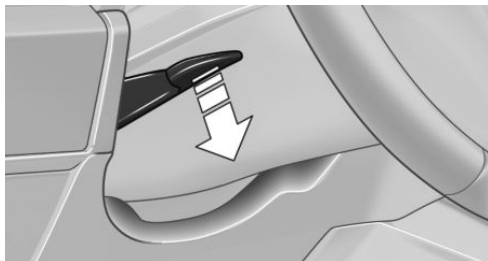
Adjusting

1. Fold the lever downwards.
2. Move the steering wheel to the preferred height and angle to suit your seated position.
3. Swing the lever back up.

Steering wheel heating**Overview**

Steering wheel heating

Switching on/off

Press the button.

- ▷ On: LED is illuminated.
- ▷ Off: LED is extinguished.

Carrying children safely

Vehicle equipment

This chapter describes all standard, national and special equipment available for the model series. Therefore equipment which is not installed in your vehicle, for example on account

of the selected optional equipment or the country specification, may also be described here. This also applies to safety-relevant functions and systems. Comply with the relevant laws and regulations when using the corresponding functions and systems.

Important considerations

Safety note



WARNING

Unsupervised children or animals in the vehicle can set the vehicle in motion and endanger themselves or other road users, for example by the following actions:

- ▷ Pressing the start/stop button.
- ▷ Releasing the parking brake.

- ▷ Opening and closing doors or windows.
- ▷ Engage selector lever position N.
- ▷ Operating vehicle equipment.

There is a risk of accident or injury. Do not leave children or animals unsupervised in the vehicle. When leaving the vehicle, take the remote control with you and lock the vehicle. ◀

Not for Australia/New Zealand: Suitable seats

Information about which child restraint systems can be used on the seats in question if the child restraint systems are attached with a

seat belt in accordance with the ECE-R 16 standard:

Group	Weight of child	Approximate age	Front passenger seat, airbag ON	Front passenger seat, airbag OFF – a)	Rear seats, outer – b)	Rear seat, middle
0	Up to 10 kg	Up to 9 months	X	U, L	U, L	X
0+	Up to 13 kg	Up to 18 months	X	U, L	U, L	X
I	9 – 18 kg	Up to 4 years	X	U, L	U, L	X
II	15 – 25 kg	Up to 7 years	X	U	U, L	X

Group	Weight of child	Approximate age	Front passenger seat, airbag ON	Front passenger seat, airbag OFF – a)	Rear seats, outer – b)	Rear seat, middle
III	22 – 36 kg	7 years or more	X	U	U, L	X

U: suitable for child restraint systems in the Universal category that have been approved for use in this weight group.

L: suitable for child restraint systems in the Semi-Universal category if the vehicle and the seat are listed in the list of vehicle models from the manufacturer of the child restraint system.

X: not suitable for child restraint systems in the Universal category that have been approved for use in this weight group.

a) Adapt the front/back position of the front passenger seat and, if necessary, move it to the highest position to achieve the best possible routing of the belt.

b) When using child restraint systems on the rear seats, adapt the front/back position of the front seat if necessary, and also adjust the head restraint of the rear seat, or remove it.

Children always in the rear seats

General

Accident research has shown that the safest place for children is on the rear seat.

Children younger than 12 years old or less than 150 cm, 5 ft in height are only allowed to be transported in the rear using child restraint systems appropriate for their age, weight and stature. Children older than 12 years must be secured with a seat belt as soon as a suitable child restraint system is no longer appropriate due to their age, weight and stature.

Safety note

 **WARNING**

Children less than 150 cm, 5 ft in height cannot wear the seat belt correctly without using additional child restraint systems. The protective effect of the seat belts can be restricted or may even fail completely if the seat belts are worn incorrectly. If a seat belt is not worn correctly, additional injuries can be caused, for example in the event of an accident or braking and evasive manoeuvres. There is a danger of

injury or even death. Children smaller than 150 cm, 5 ft in height must be secured in suitable child restraint systems. ◀

Not for Australia/New Zealand: Children on the front passenger seat

General

When using a child restraint system on the front passenger seat, make sure that the front and side airbags on the passenger side are deactivated. Front passenger airbags can only be deactivated with the key switch for front passenger airbags, see page 128.

Safety notes

 **WARNING**

Active front passenger air bags can injure a child in a child restraint system if they are triggered. There is a danger of injury. Make sure that the front passenger air bags are deactivated and the PASSENGER AIRBAG OFF indicator lamp is illuminated. ◀

**WARNING**

If the seat adjustment or child seat installation is incorrect, the child restraint system may have limited stability or may not be stable at all. There is a danger of injury or even death. Make sure the child restraint system is firmly positioned against the backrest. Wherever possible, adapt the backrest angle of all the relevant seat backrests and adjust the seats correctly. Make sure that the seats and their backrests are correctly engaged. If possible, adjust the height of the head restraints, or remove them. ◀

Fitting child restraints

General

When selecting, installing and using child restraint systems, comply with the information provided by the manufacturer of the child restraint system.

Child restraints

Appropriate child restraint systems for every age and weight class are available from a Service Partner of the manufacturer or another qualified Service Partner or a specialist workshop.

Safety notes

**WARNING**

If child restraint systems and their attachment systems have been damaged or subjected to stresses in an accident, their protective function may be restricted or may fail completely. A child might not be adequately restrained, for example, in the event of an accident or braking and evasive manoeuvres. There is a danger of injury or even death. If child restraint systems and their attachment systems have been damaged or subjected to stresses in an accident, have them checked by a Service Partner of the manufacturer or an-

other qualified Service Partner or a specialist workshop and renewed if necessary. ◀

**WARNING**

If the seat adjustment or child seat installation is incorrect, the child restraint system may have limited stability or may not be stable at all. There is a danger of injury or even death. Make sure the child restraint system is firmly positioned against the backrest. Wherever possible, adapt the backrest angle of all the relevant seat backrests and adjust the seats correctly. Make sure that the seats and their backrests are correctly engaged. If possible, adjust the height of the head restraints, or remove them. ◀

For Australia/New Zealand: installation of child restraints

Please note the following warning because your vehicle has been equipped with a front airbag for the front passenger seat that cannot be deactivated:



It is recommended not to use any kind of child restraint system on the front passenger seat.

**Extreme hazard**

Do not use a rearward-facing child restraint on a seat protected by an air bag in front of it. ◀

Not for Australia/New Zealand: On the front passenger seat

Deactivating airbags

**WARNING**

Active front passenger air bags can injure a child in a child restraint system if they are triggered. There is a danger of injury. Make sure that the front passenger air bags are deactivated and the PASSENGER AIRBAG OFF indicator lamp is illuminated. ◀

Before fitting a child restraint on the front passenger seat, make sure that the front and side airbags on the passenger side are disabled.

Deactivating the front passenger airbags with key switch, see page 128.

Rearward-facing child restraints

DANGER

Active front passenger air bags can fatally injure a child in a rearward-facing child restraint system if they are triggered. There is a danger of injury or even death. Make sure that the front passenger air bags are deactivated and the PASSENGER AIRBAG OFF indicator lamp is illuminated. ◀



Follow the information on the front passenger sun visor.

ISOFIX child seat mountings

General

Note for Australia: ISOFIX child seats are not permitted for road use in Australia at the time of printing of this handbook. However, also since a change of the respective regulations is expected in the future, lower ISOFIX ancho-

Suitable ISOFIX child restraint systems

The following ISOFIX child restraints may be used on the seats designated as appropriate for this purpose. The corresponding size class

NEVER use a rearward facing child restraint on a seat protected by an ACTIVE AIRBAG in front of it, DEATH or SERIOUS INJURY to the CHILD can occur.

Seat position and height

Before mounting a universal child restraint system, bring the front passenger seat to the rearmost position and, if possible, to the highest position to achieve the best possible routing of the belt and protection in the event of an accident.

If the upper attachment point of the seat belt is located ahead of the child seat's belt guide, carefully move the front passenger seat forwards until the best possible belt guidance is achieved.

Backrest width

With adjustable backrest width: before fitting a child restraint system on the front passenger seat, fully open the backrest width. Do not change the backrest width from this point on and do not call up a memory position.

rages are supplied in line with applicable ADRs also for Australia.

Comply with the operating and safety notes from the manufacturer of the child restraint system when attaching and using ISOFIX child restraint systems.

and size category are denoted by a letter or ISO reference on a plate on the child seat.

Group	Weight of child	Approximate age	Class/category – a)	Front passenger seat, airbag ON	Front passenger seat, airbag OFF	Rear seats, outer	Rear seat, middle
0	Up to 10 kg	Approximately 9 months	E - ISO/R1	X	X	IL	X
0+	Up to 13 kg	Approximately 18 months	E - ISO/R1	X	X	IL	X
			D - ISO/R2	X	X	IL	X
			C - ISO/R3	X	X	IL	X
I	9 - 18 kg	Up to approximately 4 years	D - ISO/R2	X	X	IL	X
			C - ISO/R3	X	X	IL	X
			B - ISO/F2	X	X	IL, IUF	X
			B1 - ISO/F2X	X	X	IL, IUF	X
			A - ISO/F3	X	X	IL, IUF	X

a) When using child seats on the rear seats, adapt the front/back position of the front seat if necessary, and also adjust the head restraint of the rear seat, or remove it.

IL: suitable for ISOFIX child restraint systems in Semi-Universal category if the vehicle and the seat are listed in the vehicle type list of the manufacturer of the child restraint system.

IUF: suitable for forward-facing ISOFIX child restraint systems in Universal category that have been approved for use in this weight class.

X: the seat is not approved or equipped with mounting points for the ISOFIX system.

Brackets for lower ISOFIX anchors

Safety note



WARNING

If the ISOFIX child restraint systems are not engaged correctly, the protective effect of the ISOFIX child restraint systems may be restricted. There is a danger of injury or even death. Make sure the lower anchor point has engaged correctly and the ISOFIX child restraint system is firmly positioned against the backrest. ◀

Position

Symbol	Meaning
	The corresponding symbol shows the brackets for the lower ISOFIX anchors.

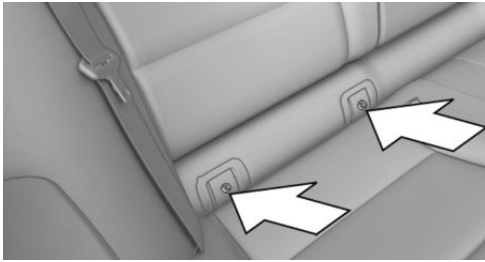

The brackets for the lower ISOFIX anchors are located behind the marked covers.

Before fitting ISOFIX child restraints

Pull the seat belt away from the area of the child seat mountings.

Fitting ISOFIX child restraint systems

1. Install the child restraint system, see manufacturer's instructions.
2. Make sure that both ISOFIX anchors are locked correctly in place.

Mounts for the upper ISOFIX retaining strap

Safety notes



WARNING

If the upper retaining strap is used incorrectly with the child restraint system, the protective effect may be reduced. There is a danger of injury. Make sure that the upper retaining strap is not routed to the upper attachment strap over sharp edges, and that it is not twisted. ◀



WARNING

If the rear backrest is not locked, the protective effect of the child restraint system is limited or non-existing. The rear backrest can fold forward in certain situations, for example braking manoeuvre or accident. There is a danger of injury or even death. Make sure that the rear backrests are locked. ◀



NOTE

The mounting points for the upper retaining straps of child restraint systems are only intended for these retaining straps. The mounting points can be damaged if other objects are attached. There is a danger of damage to property. Only attach child restraint systems to the upper retaining straps. ◀

Mounting points



The symbol shows the mounting point for the upper retaining strap.

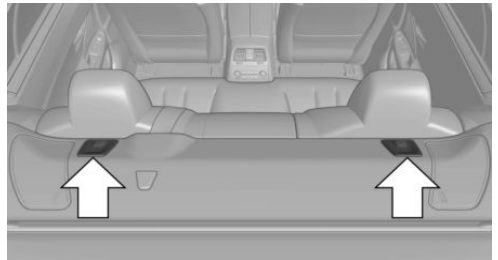

There are two mounting points for upper retaining strap of ISOFIX child restraint systems.

Routing the retaining strap

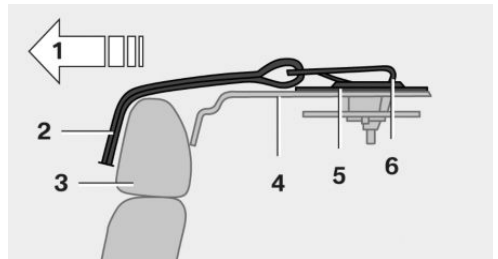

- 1 Direction of travel
- 2 Upper retaining strap
- 3 Head restraint
- 4 Rear parcel shelf
- 5 Mounting point
- 6 Hook for the upper retaining strap

Attaching the upper retaining strap to the mounting point

1. Fold up the fastening point cover.
2. Guide the upper retaining strap over the head restraint.
3. Attach the hook of the retaining strap to the mounting point.
4. Tighten the retaining strap by pulling it firmly down.

Not for Australia/New Zealand: Recommended child seats

Appropriate child restraint systems for every age and weight class are available from a Service Partner of the manufacturer or another qualified Service Partner or a specialist workshop.

- ▷ BMW Baby Seat Group 0+
- ▷ BMW Junior Seat Group 1
- ▷ BMW Junior Seat Group 2/3
- ▷ ISOFIX Base

For Australia/New Zealand: Child restraints

General

In accordance with ADR 34/02, provisions have been made to allow installation of a child restraint at each rear seating position.

The anchoring hooks which belong to the upper retaining strap of the child restraint - AS 1754, can be applied immediately to the relevant mounting.

Please refer strictly to the installation instructions supplied with the child restraint system. Each seating position is fitted with a head rest.

Safety notes



WARNING

Child restraint anchorages are designed to withstand only those loads imposed by correctly fitted child restraints. Under no circumstances are they to be used for adult seat belts, harnesses or for attaching other items or equipment to the vehicle. After using the child restraints, the anchor fittings may need to be folded down. ◀

Mounting points



The symbol shows the mounting point for the upper retaining strap.

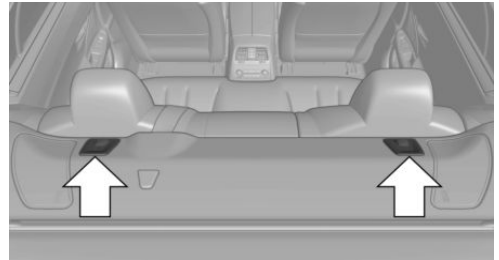

There are two mounting points for child restraints with tether straps.

Routing the retaining strap

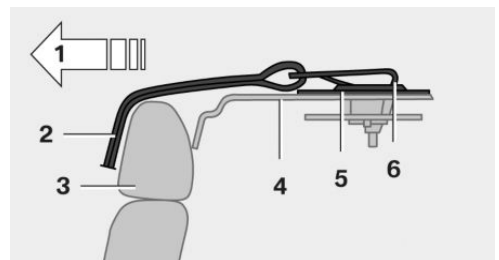

- 1 Direction of travel
- 2 Upper retaining strap
- 3 Head restraint
- 4 Rear parcel shelf

- 5 Mounting point
- 6 Hook for the upper retaining strap

Attaching the upper retaining strap to the mounting point

1. Fold up the fastening point cover.
2. Guide the upper retaining strap over the head restraint.
3. Attach the hook of the retaining strap to the mounting point.
4. Tighten the retaining strap by pulling it firmly down.

Driving

Vehicle equipment

This chapter describes all standard, national and special equipment available for the model series. Therefore equipment which is not installed in your vehicle, for example on account of the selected optional equipment or the country specification, may also be described here. This also applies to safety-relevant functions and systems. Comply with the relevant laws and regulations when using the corresponding functions and systems.

Start/stop button

Principle



The ignition is switched on or off and the engine is started by pressing the start/stop button.

M double clutch transmission: the engine starts if the brakes

are applied when the start/stop button is pressed.

Manual gearbox: the engine starts if the clutch pedal is pressed when pressing the start/stop button.

Ignition on

M double clutch transmission: press the start/stop button again without pressing the brake pedal.

Manual gearbox: press the start/stop button, do not press the clutch pedal.

All systems are operational.

Most of the indicator and warning lamps in the instrument cluster are illuminated for different lengths of time.

To save battery power when the engine is off, switch off the ignition and any unnecessary power consumers.

Ignition off

M double clutch transmission: press the start/stop button again without pressing the brake pedal.

Manual gearbox: press the start/stop button again, do not press the clutch pedal.

All indicator lamps in the instrument cluster extinguish.

To save battery power when the engine is off, switch off the ignition and any unnecessary power consumers.

Safety measures

When the ignition is switched off, transmission position P will be automatically engaged, if selector lever position D or R is engaged.

With the vehicle stationary and the engine shut down, the ignition is switched off automatically under the following circumstances:

- ▷ When locking, even with the low-beam headlights switched on.
- ▷ Shortly before the battery is discharged so that an engine start remains possible.
- ▷ When opening or closing the driver door, if the driver's belt is unfastened and the low-beam headlights are switched off.
- ▷ When the driver's belt is unfastened, if the driver door is opened and the low-beam headlights switched off.

After some minutes without further operation, the low-beam headlights are changed over to side lights.

Radio ready state

General

In the radio ready state, individual current consumers remain ready for operation.

Activating

When the engine is running, press the start/stop button.

If engine is switched off and the ignition is switched on: the system automatically activates radio ready state when the door is opened if the lights are switched off or the daytime driving lights are switched on.

Radio ready state remains active when ignition is switched off automatically, such as for the following reasons:

- ▷ Opening or closing driver door.
- ▷ Unfastening driver's seat belt.
- ▷ When low-beam headlights are automatically changed to side lights.

Switching off automatically

The radio ready state is automatically switched off in the following situations:

- ▷ If the ignition is switched off manually with the start/stop button.
- ▷ After approximately 8 minutes.
- ▷ When locking via the central locking system.
- ▷ Shortly before the battery is discharged so that an engine start remains possible.

Engine start

Safety notes



DANGER

A blocked exhaust pipe or inadequate ventilation can allow harmful exhaust fumes to penetrate the vehicle. The exhaust fumes contain pollutants which are colourless and odour-

less. In enclosed spaces, the exhaust fumes can also build up outside the vehicle. There is a danger of fatal injury. Keep the exhaust pipe clear and ensure sufficient ventilation. ◀



WARNING

An unsecured vehicle can start moving and rolling away. There is a danger of accidents. Before leaving the vehicle, secure it to prevent rolling away.

Observe the following to ensure that the vehicle is secured against rolling away:

- ▷ Apply the parking brake.
- ▷ Turn the front wheels towards the direction of the kerb on upward or downward gradients.
- ▷ Additionally secure the vehicle on upward or downward gradients, for example with a chock. ◀



NOTE

Repeated start attempts or starting several times in quick succession means that fuel is not burned or is inadequately burned. The catalytic converter can overheat. There is a danger of damage to property. Avoid repeated starting in quick succession. ◀

M double clutch transmission

Starting the engine

1. Depress the brake pedal.
2. Press the start/stop button.

The starting process is activated automatically for a short time and stops as soon as the engine starts.

Manual gearbox

Starting the engine

1. Depress the brake pedal.
2. Press the clutch and engage idle position.
3. Press the start/stop button.

The starting process is activated automatically for a short time and stops as soon as the engine starts.

Stopping the engine

Safety notes



WARNING

Unsupervised children or animals in the vehicle can set the vehicle in motion and endanger themselves or other road users, for example by the following actions:

- ▷ Pressing the start/stop button.
- ▷ Releasing the parking brake.
- ▷ Opening and closing doors or windows.
- ▷ Engage selector lever position N.
- ▷ Operating vehicle equipment.

There is a risk of accident or injury. Do not leave children or animals unsupervised in the vehicle. When leaving the vehicle, take the remote control with you and lock the vehicle. ◀



WARNING

An unsecured vehicle can start moving and rolling away. There is a danger of accidents. Before leaving the vehicle, secure it to prevent rolling away.

Observe the following to ensure that the vehicle is secured against rolling away:

- ▷ Apply the parking brake.
- ▷ Turn the front wheels towards the direction of the kerb on upward or downward gradients.
- ▷ Additionally secure the vehicle on upward or downward gradients, for example with a chock. ◀

M double clutch transmission

Stopping the engine

1. Brake the vehicle until it comes to a stop.

2. Press the start/stop button.
The engine is switched off.
The radio ready state is switched on.
3. Apply the parking brake.

Manual gearbox

Stopping the engine

1. Press the Start/Stop button when the vehicle is at standstill.
2. Engage first gear or reverse.
3. Apply the parking brake.

Auto Start Stop function

Principle

The Auto Start Stop function helps you to save fuel. The system stops the engine when stationary, for example in a traffic jam or at traffic lights. The ignition remains switched on. For driving off, the engine starts automatically.

General

Each time the engine is started via the start/stop button, the Auto Start/Stop function is switched to standby.

The function is activated from a speed of around 5 km/h, approximately 3 mph.

Stopping the engine

Operating requirements

The engine is automatically shut down when stationary under the following conditions:

M double clutch transmission:

- ▷ Selector lever in selector lever position D.
- ▷ Brake pedal remains pressed while the vehicle is at a standstill.
- ▷ Driver's seat belt buckled or driver door closed.

Manual gearbox:

- ▷ Gearbox in neutral and clutch pedal not pressed.
- ▷ Driver's seat belt buckled or driver door closed.

The air flow rate of the air conditioning system is reduced when the engine is not running.

Displays in the instrument cluster

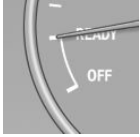

The READY display in the revolution counter indicates that the Auto Start Stop function is ready for automatic engine starting.



The display indicates that the preconditions for an automatic engine stop are not met.

Functional restrictions

The engine is not shut down automatically in the following situations:

- ▷ On steep downward gradients.
- ▷ Outside temperature too low.
- ▷ High outside temperature and operation of the automatic air conditioning.
- ▷ Interior not heated or cooled to the desired temperature.
- ▷ Engine is not yet at operating temperature.
- ▷ Sharp steering angle or steering operation.
- ▷ After reversing.
- ▷ Where there is a risk of condensation when the automatic air conditioning is switched on.
- ▷ Vehicle battery is heavily discharged.
- ▷ At high altitudes.
- ▷ Bonnet is unlocked.
- ▷ Park Assistant is activated.
- ▷ Stop-and-go traffic.
- ▷ Use of fuel with high ethanol content.

Engine start

For driving off, the engine automatically starts under the following conditions:

- ▷ M double clutch transmission: by releasing the brake pedal.
- ▷ Manual gearbox: by depressing the clutch pedal.

After starting the engine, accelerate as normal.

Safety function

After an automatic shut down, the engine will not restart automatically, if one of the following conditions is met:

- ▷ Driver's seat belt unbuckled and driver door open.
- ▷ Bonnet has been unlocked.

Several indicator lamps illuminate for various lengths of time.

The engine can only be started using the start/stop button.

Functional restrictions

Even if you do not want to drive off, the engine restarts automatically in the following situations:

- ▷ Very high temperature in the interior when the cooling function is switched on.
- ▷ The driver applies lock to the steering wheel.
- ▷ M double clutch transmission: shift from selector lever position D to N, R or D/S.
- ▷ M double clutch transmission: press the accelerator and the brake at the same time.
- ▷ Vehicle starts to roll.
- ▷ Where there is a risk of condensation when the automatic air conditioning is switched on.
- ▷ Vehicle battery is heavily discharged.
- ▷ Very low temperature in the interior when the heating is switched on.

- ▶ Low brake vacuum, for example because the brake pedal has been pressed a number of times in succession.

Preventing automatic engine stop with M double clutch transmission

Principle

To enable the vehicle to move off particularly swiftly, for example at a junction, the automatic engine stop can be actively prevented.

Preventing automatic engine stop using the brake pedal

The engine stop can be actively prevented within a second of the vehicle coming to a standstill:

- ▶ Press the brake pedal down firmly as soon as the vehicle has come to a standstill.
- ▶ Then immediately brake again with normal braking force.

Manually deactivating/activating the system

Using the button

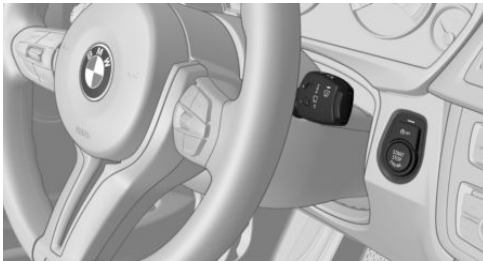

Press the button.

- ▶ LED illuminates: Auto Start Stop function is deactivated.

During an automatic engine stop, the engine is started.

The engine can be started or stopped only by means of the start/stop button.

- ▶ LED is extinguished: Auto Start Stop function is activated.

Parking the vehicle during automatic engine stop

With automatic engine stop, the vehicle can be parked safely, for example in order to leave it.

M double clutch transmission:

1. Press the start/stop button. The ignition is switched off. The Auto Start Stop function is deactivated.
Selector lever position P is automatically engaged.

2. Apply the parking brake.

Manual gearbox:

1. Press the start/stop button. The ignition is switched off. The Auto Start Stop function is deactivated.
2. Engage first gear or reverse.
3. Apply the parking brake.

Start engine as usual, using the start/stop button.

Automatic deactivation

In certain situations the Auto Start Stop function is deactivated automatically for safety reasons, for example if the absence of the driver is detected.

Malfunction

The Auto Start Stop function no longer shuts down the engine automatically. A Check Control message is shown. It is possible to keep driving. Have the system checked by a Service Partner of the manufacturer or another qualified Service Partner or a specialist workshop.

Parking brake

Safety note

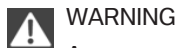

WARNING

An unsecured vehicle can start moving and rolling away. There is a danger of accidents. Before leaving the vehicle, secure it to prevent rolling away.

Observe the following to ensure that the vehicle is secured against rolling away:

- ▶ Apply the parking brake.
- ▶ Turn the front wheels towards the direction of the kerb on upward or downward gradients.
- ▶ Additionally secure the vehicle on upward or downward gradients, for example with a chock. ◀

Applying

The lever engages itself after pulling up.



The indicator lamp illuminates red. The parking brake is engaged.

If it must be used while driving by way of exception, slightly engage the parking brake while pressing and holding the button.

To avoid corrosion and one-sided braking effect, slightly pull on the parking brake from time to time when moving away, if traffic conditions allow.

The brake lights do not illuminate when the parking brake is applied.

Releasing

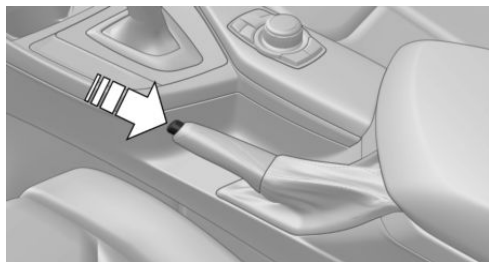

Pull up the lever a bit, press the button and guide the lever down.

Turn indicators, high-beam headlights, headlight flasher

Turn indicator

Turn indicator in exterior mirror

Do not fold in the exterior mirrors while driving or while operating the turn indicators or hazard warning lights to ensure that the turn indicators in the exterior mirrors are well recognisable.

Indicating

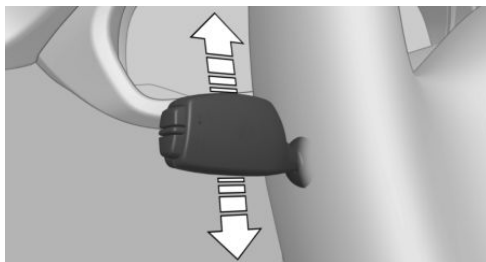

Press the lever beyond the resistance point.

Triple turn signal

Briefly press the lever up or down.

The turn indicator flashes three times.

This function can be enabled or disabled.

Via iDrive:

1. "My Vehicle"
2. "Vehicle settings"
3. "Lights"
4. "Exterior lighting"
5. "One-touch turn signal"
6. Select the desired setting.

The setting is saved for the currently used profile.

Indicating a turn briefly

Press the lever as far as the resistance point and hold it there for as long as you wish to indicate a turn.

Malfunction

If the indicator lamp flashes more rapidly than usual, a turn signal light has failed.

High-beam headlights, headlight flasher

Push the lever forwards or pull it back.

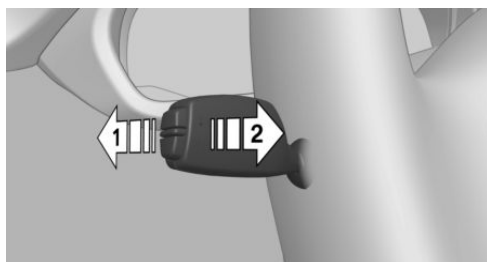

- ▷ High-beam headlights on, arrow 1.
- ▷ High-beam headlights off/headlight flasher, arrow 2.

Wiper system

General

Do not use wipers with a dry windscreen, otherwise the wiper blades will wear or become damaged more quickly.

Safety notes



WARNING

If the wipers start moving when they are folded away from the windscreen, parts of the body may become trapped or the vehicle may be damaged. There is a danger of injury or damage to property. Make sure that the vehicle is switched off when the wipers are folded away from the windscreen, and that the wipers

are in contact with the windscreen when switching on. ◀



NOTE

If the wipers are frozen to the windscreen, switching on can cause the wiper blades to tear off and the wiper motor to overheat. There is a danger of damage to property. Defrost the windscreen before switching on the wipers. ◀

Switching on

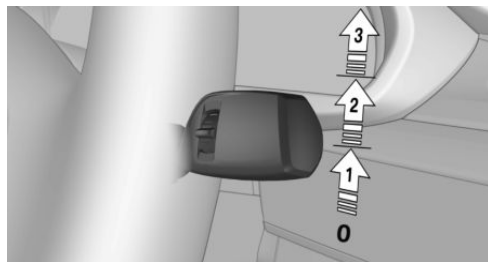

Press the lever upwards until the desired position is reached.

- ▷ Rest position of the wipers, position 0.
- ▷ Intermittent operation or rain sensor, position 1.
- ▷ Normal wiper speed, position 2.
- ▷ Fast wiper speed, position 3.

When the vehicle is at a standstill, the wipers switch to intermittent operation.

When the vehicle is at a standstill, the wipers switch to normal speed.

If a journey is interrupted with the wiper system switched on: when the journey is resumed, the wipers continue operating at the previously set level.

Switching off and flick-wiping

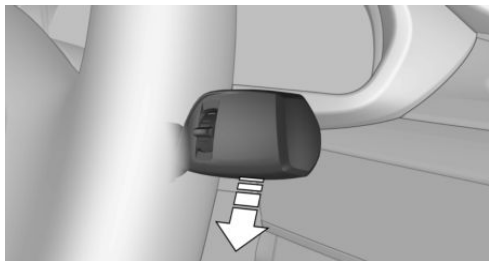

Press the lever down.

- ▷ Switching off: press lever downwards until the home position is reached.
- ▷ Flick-wiping: press lever downwards from the home position.
The lever returns to the home position when released.

Intermittent mode or rain sensor

Principle

The rain sensor automatically controls the wiper operation depending on the rain intensity.

General

The sensor is mounted on the windscreen, directly in front of the rear-view mirror. Without rain sensor, the interval for the wiper operation is specified.

Safety note



NOTE

In car washes, the wipers may inadvertently start moving if the rain sensor is activated. There is a danger of damage to property. Deactivate the rain sensor in car washes. ◀

Activating/deactivating

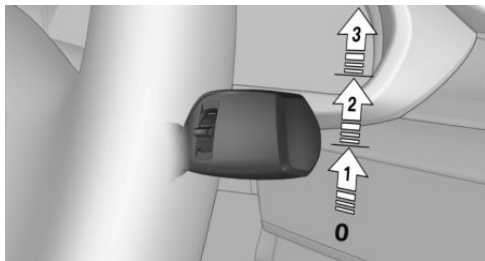

Press the lever upwards from the home position once, arrow 1.

Wiping is started.

The LED in the wiper lever is illuminated.

Setting the interval time or sensitivity of the rain sensor

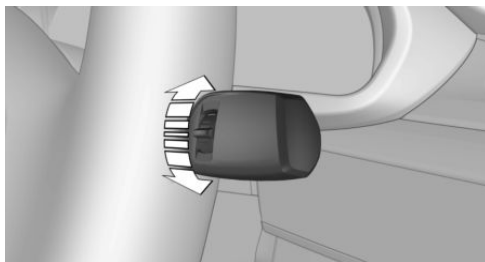

Turn the knurled wheel to set the interval time or sensitivity of the rain sensor.

Up: short interval or high sensitivity of the rain sensor.

Down: long interval or low sensitivity of the rain sensor.

Windscreen and headlight washer

Safety notes



WARNING

At low temperatures, the washer fluid can freeze onto the windscreen and restrict visibility. There is a danger of accidents. Only use the washer systems if there is no possibil-

ity of the washer fluid freezing. Use anti-freeze if required. ◀

NOTE

If the washer fluid reservoir is empty, the washer pump cannot operate as intended. There is a danger of damage to property. Do not use the washer system with the washer fluid reservoir empty. ◀

To clean the windscreen

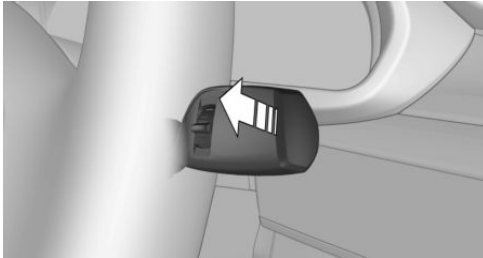

Pull the lever.

Fluid from the washer fluid reservoir is sprayed onto the windscreen and the wipers are operated briefly.

When the vehicle's lights are switched on, the headlights are also cleaned simultaneously at practical intervals.

Windscreen washer jets

Both windscreen washer jets are automatically heated when the ignition is switched on.

Fold-out position of the wipers

Principle

In the fold-out position, the wipers can be folded away from the windscreen.

General

This is important, for example for replacing the wiper blades or folding them out in the event of frost.

Safety notes

WARNING

If the wipers start moving when they are folded away from the windscreen, parts of the body may become trapped or the vehicle may be damaged. There is a danger of injury or damage to property. Make sure that the vehicle is switched off when the wipers are folded away from the windscreen, and that the wipers are in contact with the windscreen when switching on. ◀

NOTE

If the wipers are frozen to the windscreen, switching on can cause the wiper blades to tear off and the wiper motor to overheat. There is a danger of damage to property. Defrost the windscreen before switching on the wipers. ◀

Folding out the wipers

1. Switch ignition on and back off again.
2. Press the button on the wiper lever down and hold until the wipers stop in an approximately vertical position.

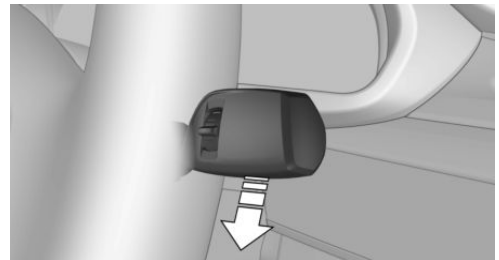

- Lift wipers completely away from the windscreen.

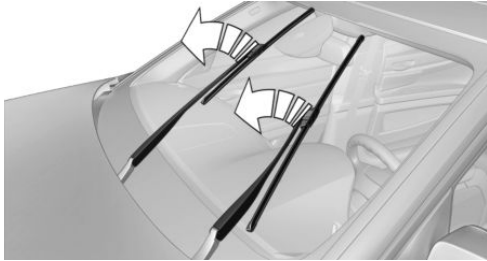

Fold in the wipers

After folding the wipers in, the wiper system must be reactivated.

1. Fold in the wipers completely onto the windscreen.
2. Switch on the ignition.
3. Press the wiper lever downwards. The wipers move back to the rest position and are operational once again.

Washer fluid

General

All washer jets are supplied from one tank.

Use a mixture of tap water and screenwash concentrate for the windscreen washer, if necessary with the addition of anti-freeze.

Recommended minimum fill level: 1 litre, approximately 1.7 Imp. pints.

Safety notes

- WARNING**
- Some anti-freezes can contain toxic substances, and are flammable. There is a risk of fire and fatal injury. Comply with the notes on the containers. Keep anti-freezes away from sources of combustion. Do not pour service products into other bottles. Keep service products out of the reach of children. ◀

- WARNING**

Washer fluid can ignite on contact with hot parts of the engine, and catch fire. There is a danger of injury or damage to property. Only top up washer fluid when the engine has cooled down. Then fully close the cap of the washer fluid reservoir. ◀

- NOTE**

Additives containing silicone added to the washer fluid for their water beading effect on the windows can lead to damage to the washer system. There is a danger of damage to property. Do not add any additives containing silicone to the washer fluid. ◀

- NOTE**

Mixing different screenwash concentrates or anti-freezes can result in damage to the washer system. There is a danger of damage to property. Do not mix different screenwash concentrates or anti-freezes. Comply with the instructions and mixing ratios stated on the containers. ◀

Overview

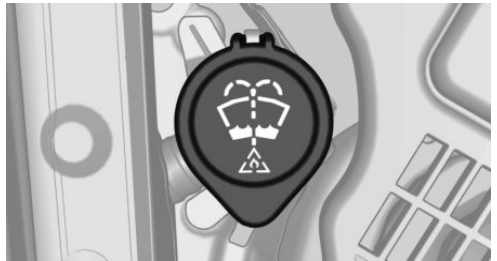

The reservoir for the washer fluid is located in the engine compartment.

Malfunction

Using undiluted screenwash concentrate or anti-freeze made of alcohol can lead to incorrect indications at low temperatures below $-15^{\circ}\text{C}/+5^{\circ}\text{F}$.

Manual gearbox

Safety notes



WARNING

An unsecured vehicle can start moving and rolling away. There is a danger of accidents. Before leaving the vehicle, secure it to prevent rolling away.

Observe the following to ensure that the vehicle is secured against rolling away:

- ▷ Apply the parking brake.
- ▷ Turn the front wheels towards the direction of the kerb on upward or downward gradients.
- ▷ Additionally secure the vehicle on upward or downward gradients, for example with a chock. ◀



NOTE

When shifting into a lower gear, high engine speeds can damage the engine. There is a danger of damage to property. Push the shift lever to the right while shifting into the 5th or 6th gear. ◀

Schematic diagram

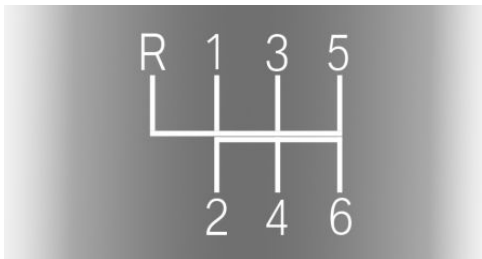

- ▷ 1 – 6: forward gears
- ▷ R: reverse gear

Shifting gears

General

Depending on the engine version, the engine speed is automatically adjusted as required

during a gear shift for a harmonious and dynamic gear change.

Reverse gear

Engage this position only when the vehicle is stationary.

To overcome the resistance, move the shift lever firmly to the left towards the left and engage the reverse gear with a gear shift movement forwards.

Rolling or pushing the vehicle

In some situations, the vehicle is to roll without its own power, for example in a car wash, or be pushed.

1. Switch on the ignition.
2. Press the clutch and change out of a forward gear or reverse.
3. Releasing the parking brake.

M double clutch transmission with Drivelogic

General

The M double clutch transmission with Drivelogic is an automated manual gearbox with two clutches and partial gears, by which the gears are changed without interrupting traction.

It is operated using the selector lever or two shift paddles on the steering wheel.

Functions

- ▷ Drive mode or Sequential mode.
- ▷ Various drive programs, Drivelogic.
- ▷ Shift Lights.
- ▷ Automatic downshift and protection against shifting even in Sequential mode.
- ▷ Launch Control.
- ▷ Low Speed Assistant.

Safety note

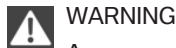

WARNING

An unsecured vehicle can start moving and rolling away. There is a danger of accidents. Before leaving the vehicle, secure it to prevent rolling away.

Observe the following to ensure that the vehicle is secured against rolling away:

- ▷ Apply the parking brake.
- ▷ Turn the front wheels towards the direction of the kerb on upward or downward gradients.
- ▷ Additionally secure the vehicle on upward or downward gradients, for example with a chock. ◀

Selector lever, selector lever position

Overview



- ▷ R: reverse.
- ▷ N: neutral, idling.
- ▷ Centre position, forward setting.
- ▷ +: manually change up.
- ▷ -: manually change down.
- ▷ D/S: change between Drive mode and Sequential mode.

Engaging selector lever position

Depress the brake pedal and push or pull the selector lever in the appropriate direction.

As soon as the selector lever is released, it returns to the central position. The selector lever engages into position R.

The engaged selector lever position is shown in the instrument cluster and on the selector lever.

After a selector lever position has been engaged, the vehicle can roll away when the brake is released, for example on a downhill slope. As a result, drive away immediately after releasing the brake.

Use the Low Speed Assistant when manoeuvring or in stop-and-go traffic.

Low Speed Assistant

Principle

The Low Speed Assistant provides support at very low speeds. The vehicle drives at walking pace.

Can also be used for rocking out on snow. To do that, shift between reverse gear and forward position, without apply the brakes.

Safety note



NOTE

The transmission can overheat when using the function and pressing the brake pedal at the same time for an extended time. There is a danger of damage to property. Do not brake for an extended time when using the function. ◀

Activating

1. Engage a drive position.
2. Briefly tap on the accelerator pedal.

In 1st and 2nd gear and in reverse gear, the vehicle rolls at minimum speed.

Deactivating

Brake the vehicle until it comes to a stop.

Flashing display on selector lever of double clutch transmission

In some situations, the actually engaged gearbox setting may be different from the selector

lever position, and the display in the selector lever flashes.

In these cases, refer to the display in the instrument cluster.

D Drive mode

In Drive mode, all forward gears are automatically changed.

Kick-down: for maximum acceleration, for example, when overtaking. To do that, press the accelerator pedal beyond the resistance point.

Change to Sequential mode: shift using the shift paddles or push the selector lever in the D/S direction.

S Sequential mode

Change up or change down using the shift paddle or selector lever without coming off the gas.

- ▶ Shortly before a minimum speed depending on the gear, it automatically downshifts.
- ▶ The gears are only shifted up or down with the appropriate engine speed and road speed.

For example, there is no downshift at too high an engine speed.

- ▶ **Kick-down:** by operating the kick-down and the left shift paddle or selector lever at the same time, you can change down to the lowest possible gear.
- ▶ Driving off is possible even in 2nd gear on a level carriageway, for example, when it is smooth.

To change to Drive mode: press selector lever in the D/S direction.

R Reverse

Engage this position only when the vehicle is stationary.

For rocking out, even up to 10 km/h, approximately 6 mph is possible. To do that, shift be-

tween forward and reverse gear without applying the brakes.

N Neutral, idling

In selector lever position N, the vehicle can roll, for example in car washes, see page 244.

P Park

The drive gears are locked.

Transmission position P is engaged automatically:

- ▶ After stopping the engine in the radio ready state, see page 86, or ignition off, see page 85, when position R or D is engaged.
- ▶ Position N is engaged and ignition is off.

Rolling or pushing the vehicle

General

In some situations, the vehicle is to roll without its own power for a short distance, for example in a car wash, or be pushed.

Engaging selector lever position N

1. Start the engine with the brake pressed.
2. If necessary, release the parking brake.
3. Depress the brake pedal.
4. Engage selector lever position N.
5. Stop the engine.

In this way the ignition remains switched on and a Check Control message is displayed.

The vehicle will be able to roll.



NOTE

Selector lever position P is automatically engaged when the ignition is switched off. There is a danger of damage to property. Do not switch the ignition off in car washes. ◀

Irrespective of the ignition, the selector lever position P is engaged automatically after approximately 15 minutes.

Displays in the instrument cluster

Drive mode

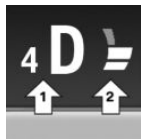

- ▷ Engaged gear together with a D, arrow 1.
- ▷ Selected drive programme, Drivelogic, see page 98, arrow 2.

Sequential mode



- ▷ Engaged gear, arrow 1.
- ▷ Selected drive programme, Drivelogic, see page 98, arrow 2.
- ▷ Shift point indicator, see page 110

Note

At very low outside temperatures, the display may not function. The current direction of travel can be recognised from the engaged selector lever position.

Changing gear

General

Changing is possible in Sequential mode.

Changing in Drive mode has the effect of changing to Sequential mode.

Via the selector lever

- ▷ To shift up: pull the selector lever backwards.
- ▷ To shift down: press the selector lever forwards.

Using the shift paddles on the steering wheel

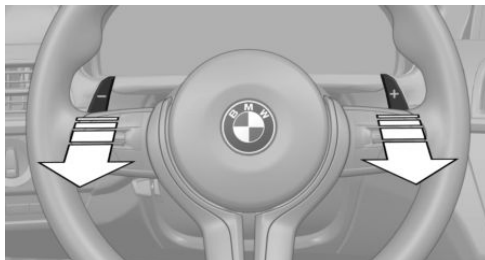

- ▷ Change up: pull right shift paddle.
- ▷ Change down: pull left shift paddle.

Drivelogic

General

Various drive programs are available.

After each change between Sequential mode and Drive mode, the last programme selected is active.

Exception: after each engine start, drive programme 1 in Drive mode is active.

In Drive mode

Three drive programs can be selected:

- ▷ D1: efficient driving.
- ▷ D2: relaxed driving.
- ▷ D3: sporty driving.

In Sequential mode

Three drive programs can be selected:

- ▷ S1: comfortable gearshifts.
- ▷ S2: sporty, crisp gearshifts.
- ▷ S3: maximum gearshift speed, Launch Control.

Selecting drive programme using button in centre console



 Press button until desired drive programme is displayed in instrument cluster.

Selecting drive programme using M Drive

On the Control Display:

1. "My Vehicle"
2. "M Drive 1" or "M Drive 2"
3. "Transmission"
4. Turn the Controller until the desired setting is reached and press the Controller.
 - ▷ "D1" to "D3": Drive mode.
 - ▷ "S1" to "S3": Sequential mode.
5. Set other drive programs as necessary.

Setting is immediately accepted with active M Drive.

To activate the desired M Drive with the selected settings, press the corresponding button on the steering wheel:



 **WARNING**

Depending on the settings, DSC may only be available to a limited extent or not at all. There is a danger of accident or damage to property. Observe the settings for DSC in

M Drive and react actively if necessary. Adjust the driving style and react if necessary. ◀

Display in the instrument cluster



Selected drive programme corresponds to the number of illuminated fields.

Launch Control

Principle

Launch Control allows optimum acceleration when driving off on a non-slip road surface.

General

Use of Launch Control causes premature component wear, as the function subjects the vehicle to very high stresses and loads.

Do not use Launch Control when running in, see page 192.

Requirements

Launch Control is available when the engine is at operating temperature, that is after an uninterrupted journey of at least 10 km, approximately 6 miles.

To start with Launch Control, do not turn the steering wheel.

Activating Launch Control

1. Deactivate Dynamic Stability Control, see page 150.
2. Select Sequential mode with gear 1 and drive programme 3.
3. With the engine running, depress the brake pedal with the left foot.
4. Press accelerator pedal fully.
 - The starting engine speed is adjusted.
 - The flag symbol appears in the instrument cluster.

5. Using the Cruise Control, change the engine speed when driving off by 500 rpm.
6. Release brake, vehicle accelerates. Continue to press accelerator pedal.
Upshifting happens automatically as long as the accelerator pedal is fully pressed.

Launch Control is only available again after a certain distance has been travelled.

System limits

This gearbox has overheat protection, which protects the clutch against extreme loads.



- ▷ Indicator lamp illuminates yellow: gearbox too hot.
Avoid high engine load and frequent driving off.
- ▷ Indicator lamp illuminates red: gearbox overheated.
Moderate continued driving possible. Stop at the next opportunity, stop the engine and allow the gearbox to cool.

Avoid frequent, heavy driving off and on upward gradients, do not hold the vehicle by slightly giving gas with sliding clutch, otherwise the gearbox may overheat.

In traffic queues or at very low speeds, use the Low Speed Assistant, see page 96.

M Engine Dynamics Control

Principle

The M Engine Dynamics Control affects the response of the vehicle to movements of the accelerator pedal.

Programs

Possibilities for adjusting the responsiveness:

- ▷ "Sport Plus": spontaneous, direct. Maximum dynamics.
- ▷ "Sport": sporty, dynamic.

- ▷ "Efficient": efficient, comfortable. Minimised consumption
Ideal, for example, in city traffic or on snow.

Selecting a channel

Via M Drive

On the Control Display:

1. "My Vehicle"
2. "M Drive 1" or "M Drive 2"
3. "Engine"
4. Select the desired channel.

Setting is immediately accepted with active M Drive.

To activate the desired M Drive with the selected settings, press the corresponding button on the steering wheel:

▷



▷



Using the button



- ▷ Press button until the desired programme is displayed in the instrument cluster.

Display in the instrument cluster



- ▷ Engine dynamics control with selected programme with activated display of the system states of the driving dynamics, see page 108.

Displays

Vehicle equipment

This chapter describes all standard, national and special equipment available for the model series. Therefore equipment which is not installed in your vehicle, for example on account

of the selected optional equipment or the country specification, may also be described here. This also applies to safety-relevant functions and systems. Comply with the relevant laws and regulations when using the corresponding functions and systems.

Overview, Instrument cluster

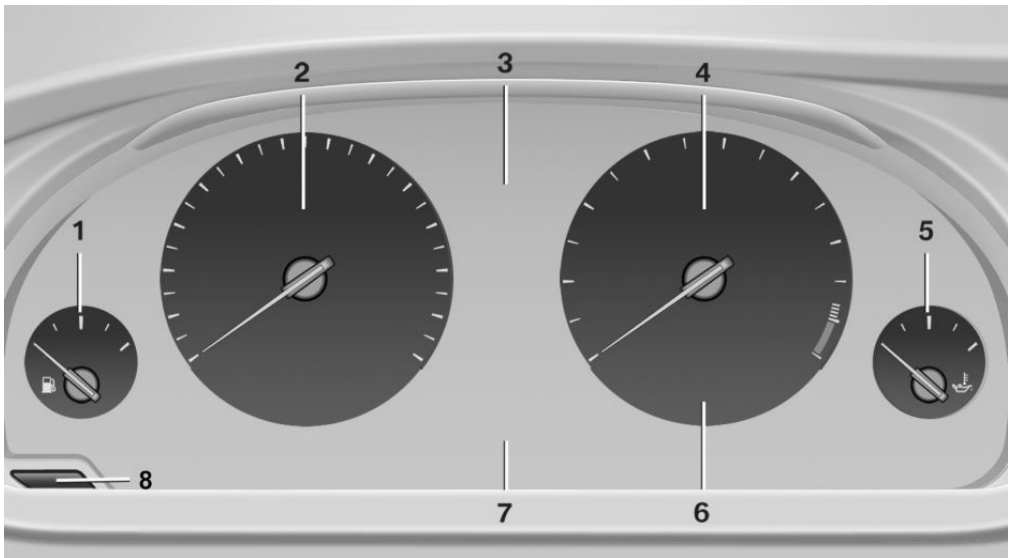

- | | |
|--|--|
| 1 Fuel gauge 105 | Shift Lights 118 |
| 2 Speedometer | 5 Engine oil temperature 106 |
| 3 Messages, for example, Check Control | 6 Current fuel consumption |
| 4 Revolution counter 105 | 7 Electronic displays |
| | 8 Reset kilometres 106 |

Check Control

Principle

The Check Control monitors vehicle functions and alerts you to any faults in the monitored systems.

General

A Check Control message is displayed as a combination of indicator or warning lights and text messages in the instrument cluster and the Head-Up Display.

If applicable, the text message shown in the Control Display is accompanied by an additional acoustic signal.

Indicator and warning lamps

General

Indicator and warning lights in the instrument cluster can illuminate in a variety of combinations and colours.

When the engine starts or the ignition is switched on, the functionality of some lights is briefly checked.

Red lights

Seat belt reminder



The driver's side seat belt is not fastened. For some country versions: front passenger seat belt is not fastened or objects are detected on the front passenger seat.

If the indicator lamp flashes or is illuminated: seat belt on the driver's or front passenger side is not fastened. The seat belt reminder can also be triggered if there are objects in the front passenger seat.

Check whether the seat belt has been fastened correctly.

Seat belt reminder for rear seats



Red: seat belt not fastened on the corresponding rear seat.

Green: seat belt fastened on the corresponding rear seat.

Airbag system



Airbag system and belt tensioner may be faulty.

Immediately have the vehicle checked by a Service Partner of the manufacturer or an-

other qualified Service Partner or a specialist workshop.

Parking brake



The parking brake is engaged.

Releasing the parking brake, see page 90.

Front-end collision warning



Indicator lamp is illuminated: forewarning, for example if a danger of collision is anticipated or there is a very short

distance to a vehicle ahead.

Increase the distance.

Indicator lamp flashes: acute warning in the event of an immediate collision if the vehicle approaches another vehicle with relatively high differential speed.

Intervene by braking and, if necessary, performing an evasive manoeuvre.

Person warning



Symbol in the instrument cluster.

If there is a risk of collision with a detected person, the symbol illuminates and a signal sounds.

Yellow lights

Anti-lock Brake System, ABS



Braking force boost may be faulty.

Avoid sudden braking. Take into account that the braking distance will be

longer.

Have the vehicle checked immediately by a Service Partner of the manufacturer or another qualified Service Partner or a specialist workshop.

Dynamic Stability Control DSC



If the indicator lamp is flashing: DSC is regulating the acceleration and braking forces. The vehicle is stabilised. Decrease speed and adjust driving style to the road conditions.

If the indicator lamp is illuminated: DSC has failed.

Have the system checked by a Service Partner of the manufacturer or another qualified Service Partner or a specialist workshop.

Dynamic Stability Control DSC, see page 150.

Dynamic Stability Control DSC deactivated



Dynamic Stability Control DSC is deactivated.

Dynamic Stability Control DSC, see page 150.

M Dynamic Mode



M Dynamic Mode MDM is switched on.
M Dynamic Mode, see page 151.



Indicator lamp also flashes: MDM regulates acceleration and braking forces. The vehicle is stabilised.



Indicator lamp is illuminated: MDM has failed. Have the system checked by a Service Partner of the manufacturer or another qualified Service Partner or a specialist workshop.



M Dynamic Mode, see page 151.

Runflat indicator RPA



The runflat indicator reports a loss of tyre inflation pressure in a tyre.

Reduce your speed and carefully stop the vehicle. Avoid violent or sudden braking and steering manoeuvres.

Runflat indicator, see page 133.

Tyre Pressure Monitor TPM



The indicator lamp is illuminated.

The Tyre Pressure Monitor reports a low tyre inflation pressure or a flat tyre.

Note the information in the Check Control message.

The warning lamp flashes and is then illuminated continuously.

No flat tyres or loss of tyre inflation pressure can be detected.

- ▶ Fault due to systems or devices with the same frequency: the system is automatically reactivated upon leaving the field of interference.
- ▶ TPM could not shut down the reset: execute a reset of the system again.
- ▶ A wheel without TPM wheel electronics is fitted: have it checked by a Service Partner of the manufacturer or another qualified Service Partner or a specialist workshop if necessary.
- ▶ Malfunction: have the system checked by a Service Partner of the manufacturer or another qualified Service Partner or a specialist workshop.

Tyre Pressure Monitor, see page 130.

Steering system



Steering system faulty.

Have the system checked by a Service Partner of the manufacturer or another qualified Service Partner or a specialist workshop.

Emissions



Engine function malfunctioning.

Have the vehicle checked by a Service Partner of the manufacturer or another qualified Service Partner or a specialist workshop.

Socket for on-board diagnosis, see page 230.

Lane Departure Warning



System is switched on and warns you under certain conditions if you leave a detected lane without indicating first.

Lane Departure Warning, see page 140.

Rear fog light



The rear fog lights are switched on.

Rear fog light, see page 124.

Green lights

Turn indicator



The turn indicator is switched on.

If the indicator lamp flashes more rapidly than usual, a turn signal light has failed.

Turn indicators, see page 90.

Side lights, driving lights



The side lights or driving lights are switched on.

Side lights / low-beam headlights, driving lights control, see page 120.

High-beam assistance



High-beam assistance is switched on.

The high-beam headlights are switched on and off automatically depending on the traffic situation.

High-beam assistance, see page 123.

Cruise Control



The system is switched on. The speed set using the controls on the steering wheel is maintained.

Manual speed limiter



Indicator lamp is illuminated: system is switched on.

Indicator lamp flashes: set speed limit is exceeded. An acoustic signal may sound.

Reduce speed or deactivate system.

Blue lights

High-beam headlights



The high-beam headlights are switched on.

High-beam headlights, see page 91.

Hiding Check Control messages

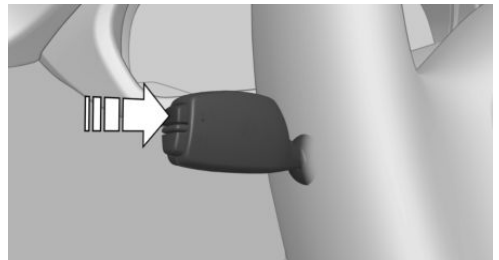

Press the button on the turn indicator lever.

Continuous display

Some Check Control messages are displayed permanently and remain until the fault has been repaired. If there are a number of malfunctions simultaneously, the messages are displayed in succession.

These messages can be hidden for approximately 8 seconds. They are then displayed again automatically.

Temporary display

Other Check Control messages are automatically hidden after approximately 20 seconds. These Check Control messages remain saved and can be displayed again.

Displaying Check Control messages saved in the memory

Via iDrive:

1. "My Vehicle"
2. "Vehicle status"
3.  "Check Control"
4. Select a text message.

Display

Check Control



At least one Check Control message is displayed or saved.

Text messages

Text messages and symbols in the instrument cluster explain the meaning of a Check Control message and the indicator and warning lights.

Supplementary text messages

You can call up additional information, for example the cause of the fault and any action required, via Check Control.

The supplementary text is automatically shown in the Control Display for urgent messages.

Functions

Depending on the Check Control message, the following functions can be selected.

- ▷ "Owner's Handbook"

Display additional information on the Check Control message in the integrated Owner's Handbook.

- ▷ "Service request"
Contact a Service Partner of the manufacturer or another qualified Service Partner or a specialist workshop.
- ▷ "BMW Roadside Assistance"
Contact breakdown assistance.

Messages displayed at the end of a journey

Certain messages displayed when driving are displayed again when the ignition is switched off.

Fuel gauge



Depending on the equipment, the arrow next to the petrol pump symbol shows on which side of the vehicle the petrol tank flap is.

The angle of the vehicle may cause the display to fluctuate.

Notes on refuelling, see page 204.

Revolution counter



Yellow and red LEDs display permitted engine speed range. Permitted engine speed increases as engine oil temperature rises.

Avoid engine speeds in the yellow warning zone if possible.

It is vital to avoid engine speeds in the red warning zone. In this zone, the fuel supply is interrupted to protect the engine.

Engine oil temperature



- ▶ Cold engine: the pointer is located at a low temperature value. Drive with moderate engine speed and vehicle speed.
- ▶ Normal operating temperature: the needle is located in the centre or left half of the temperature display.
- ▶ Hot engine: the pointer is located at a high temperature value. A Check Control message is also displayed.

Coolant temperature

If the coolant and therefore the engine become too hot, a Check Control message is displayed. Checking coolant level.

Odometer and trip distance recorder

Display

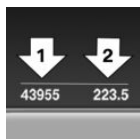

- ▶ Odometer, arrow 1.
- ▶ Trip distance recorder, arrow 2.

Showing/resetting distance



- Press the button.
- ▶ When the ignition is off, the time, outside temperature and odometer are displayed.
 - ▶ When the ignition is on, the trip distance recorder is reset.

Outside temperature



WARNING

Even at temperatures above +3 °C/+37 °F, there may be an increased risk of black ice, for example on bridges or on shaded roads. There is a danger of accidents. At low temperatures, adjust the driving style to the weather conditions. ◀

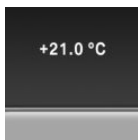

If the display drops to +3 °C/+37 °F or lower, a signal sounds. A Check Control message is shown.

There is an increased risk of black ice.

If the digital speedo is activated, the outside temperature can be displayed on the on-board computer.

Time

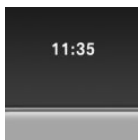

The time is shown in the instrument cluster.

If the digital speedo is activated, the time can be displayed on the on-board computer.

The time can be set on the Control Display.

Date

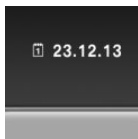

The date is displayed on the on-board computer.

The date and date format can be set on the Control Display.

Digital speedometer

Display

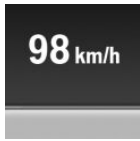

The current speed is shown in the instrument cluster.

Activating display

1. "My Vehicle"
2. "iDrive settings"
3. "Displays"
4. "Instrument cluster"
5. "Digital speedometer"

Setting unit

1. "My Vehicle"
2. "iDrive settings"
3. "Units"
4. "Dgtl speedo:"
5. Select the desired unit.

The setting is saved for the currently used profile.

Gear display with Drivelogic

Sequential mode



- ▶ Engaged gear, arrow 1.
- ▶ Selected drive programme, Drivelogic, arrow 2.

Drive mode



- ▶ Engaged gear together with a D, arrow 1.
- ▶ Selected drive programme, Drivelogic, arrow 2.

Range

Display

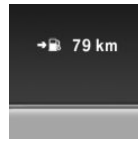

If the remaining range is low:

- ▶ A Check Control message is briefly displayed.
- ▶ The on-board computer shows the remaining range.
- ▶ If a dynamic driving style is adopted, for example fast cornering, engine function is not always ensured.

If the range drops below approximately 50 km, approximately 30 miles the Check Control message is continually displayed.



NOTE

If the range drops below 50 km, approximately 30 miles, the engine may no longer be supplied with sufficient fuel. Engine function is no longer ensured. There is a danger of damage to property. Refuel in good time. ◀

Current fuel consumption

Display



Shows the momentary fuel consumption. It is possible to check the economy and environmental compatibility of your driving style.

Displaying the current fuel consumption

Via iDrive:

1. "My Vehicle"
2. "iDrive settings"
3. "Displays"
4. "Instrument cluster"
5. If necessary, "M driving dynamics systems"

The current fuel consumption display is active.

Display of the driving dynamic systems, see page 108.

The bar gauge for the current fuel consumption is shown in the instrument cluster.

Energy recuperation

Display



In overrun mode, the kinetic energy of the vehicle is converted into electrical energy. The vehicle battery is partially charged and fuel consumption can be

lowered.

Displaying energy recuperation

1. "My Vehicle"
2. "iDrive settings"
3. "Displays"
4. "Instrument cluster"
5. If necessary, "M driving dynamics systems"

The energy recuperation display is active.

Display of the driving dynamic systems, see page 108.

EfficientDynamics display

Displaying EfficientDynamics

When travelling, information on consumption and technology is shown.

1. "My Vehicle"
2. "Technology in action"
3. "EfficientDynamics"

Showing fuel consumption history

The average fuel consumption can be shown in the set time span.

1. "My Vehicle"
2. "Technology in action"
3. "EfficientDynamics"
4.  Select the symbol.

Selecting the route length

1.  Press the button.
2. Select the desired route length or scaling.

Resetting fuel consumption history

1.  Press the button.
2. "Reset consumption history"

Showing EfficientDynamics Info

The current effectiveness can be shown.

1. "My Vehicle"
2. "Technology in action"
3. "EfficientDynamics"
4.  Select the symbol.

The following systems are shown:

- ▷ Auto Start Stop function.
- ▷ Energy recuperation.
- ▷ Air conditioning power.

Driving dynamic systems

Display



The system states of the driving dynamics are shown in the instrument cluster.

Symbols	Description
	M engine dynamics control, see page 100.
	Adaptive M suspension, see page 153.
	Servotronic, see page 154.



Activating display

- "My Vehicle"
- "iDrive settings"
- "Displays"
- "Instrument cluster"
- If necessary, "M driving dynamics systems"
 - The drive dynamics systems display is active.
 - Display Current consumption, see page 107, and Energy recovery, see page 108.

Service requirements

Principle

The function shows the current service requirements and related maintenance jobs.

General

The distance to be driven or time to the next maintenance is displayed briefly after switching on the ignition briefly in the instrument cluster.

The current service requirements can be read out from the remote control by a service advisor.

Display

Detailed information on service requirements

More detailed information on the scope of maintenance can be displayed on the Control Display.

Via iDrive:

- "My Vehicle"
- "Vehicle status"
-  "Service requirements"

Essential maintenance routines and any statutory inspections required are displayed.
- Select an entry to display more detailed information.

Symbols

Symbols	Description
	No servicing is currently needed.
	Maintenance or an inspection required by law is due soon.
	Servicing is overdue.



Entering deadlines

Enter deadlines for prescribed statutory vehicle inspections.

Ensure that the data and time are set correctly in the vehicle.

Via iDrive:

- "My Vehicle"
- "Vehicle status"
-  "Service requirements"
- "Vehicle inspection"
- "Date:"

6. Select the desired setting.
7. Confirm.
The entered date is saved.

Automatic Service notification

Data on the service status or on statutory inspections for the vehicle is transmitted to the Service partner automatically when a service or inspection is imminent.

It is possible to check when the Service Partner was notified.

Via iDrive:

1. "My Vehicle"
2. "Vehicle status"
3.  "Teleservice Call"

Service history

Principle



Maintenance that has been performed can be displayed on the Control Display. The function is available as soon as a maintenance visit has been documented in the vehicle data.

General



Have maintenance work performed by a Service Partner of the manufacturer or another qualified Service Partner or a specialist workshop. The maintenance work carried out is recorded in the vehicle data.

Displaying service history

Via iDrive:

1. "My Vehicle"
2. "Vehicle status"
3.  "Service requirements"
4.  "Service history"
Performed maintenance is shown.
5. Select an entry to display more detailed information.

Symbols

Symbols	Description
	Green: maintenance has been carried out on time.
	Yellow: maintenance has been carried out with a delay.
	Maintenance has not been carried out.

Shift point indicator

Principle

The system recommends the most efficient gear for the current driving situation.



General

The shift point indicator is active in Sequential mode of the M double clutch transmission and the manual gearbox.

Information on up or down shifting are displayed in the instrument cluster.

For vehicles without shift point indicator, the gear engaged is shown.

Displays

Symbol	Description
	Shift up into most efficient gear.
	Shift down into most efficient gear.

Speed Limit Info with overtaking restriction display

Speed Limit Info

Principle

Speed Limit Info shows the currently detected speed limit in the instrument cluster.

General

The camera in the area of the interior rear-view mirror detects traffic signs at the edge of the road as well as variable overhead signs. Traffic signs with additional symbols, for example in wet conditions, are also detected, compared with internal vehicle data, for example of the rain sensor, and displayed, depending on the situation. The system considers the information saved in the navigation system and also displays the speed limits present on unmarked sections of road.

Overtaking restriction display

Principle

Overtaking restriction signs and end of restriction signs that are detected by the camera are indicated by corresponding symbols in the instrument cluster.

General

The system only considers no passing restrictions and ends of restrictions that are indicated by means of signs.

Nothing will be displayed in the following situations:

- ▶ In countries in which no passing is primarily shown by road markings.
- ▶ On routes without signage.
- ▶ In the case of railway crossings, lane markings and other situations which indicate a no passing restriction but which are not sign-posted to this effect.

Safety note



WARNING

The system does not release you from your personal responsibility to assess the visibility conditions and traffic situation correctly. There is a danger of accidents. Adapt your driving style to the traffic conditions. Observe the traffic situation and intervene actively if the situation warrants it. ◀

Overview

Camera

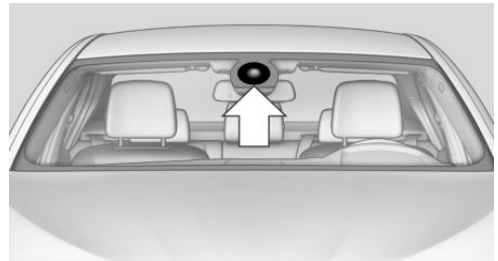

The camera is located on the front side of the rear-view mirror.

Keep the windscreen clean and clear in the area in front of the rear-view mirror.

Switching on/off

Via iDrive:

1. "My Vehicle"
2. "iDrive settings"
3. "Displays"
4. "Instrument cluster"
5. "Speed Limit Info"

If Speed Limit Info is switched on, this can be shown via the on-board computer on the information display in the instrument cluster.

Overtaking restrictions are also displayed when Speed Limit Info is activated.

Display

The following appears in the instrument cluster:

Speed Limit Info

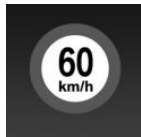

Present speed limit.

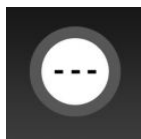

Speed Limit Info unavailable.

Speed Limit Info can also be shown in the Head-Up Display.

Overtaking restriction display

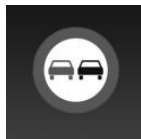

No passing restriction.

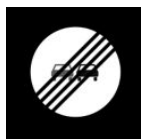

End of no passing restriction.

Overtaking restrictions can also be shown in the Head-Up Display.

System limits

The function may be disabled or inaccurate under certain conditions, for example:

- ▷ In thick fog, wet conditions or snow.
- ▷ If signs are fully or partially obscured by objects, stickers or paint.
- ▷ If the vehicle is moving too close to the vehicle ahead.
- ▷ In the case of bright oncoming light or strong reflections.

- ▷ When the windscreen in front of the rear-view mirror is covered with condensation, dirt, stickers, etc.
- ▷ Possible incorrect detection by the camera.
- ▷ If the speed limits saved in the navigation system are wrong.
- ▷ In areas not covered by the navigation system.
- ▷ If there are deviations in relation to the navigation, for example due to changes in the road routing.
- ▷ When overtaking buses or trucks with speed stickers.
- ▷ If traffic signs do not correspond to the standard.
- ▷ During the camera calibration process immediately after vehicle delivery.
- ▷ If signs are detected that apply to a parallel road.

Selection lists

General

Depending on equipment, the following can be displayed or operated via the buttons and the knurled wheel on the steering wheel, using the displays in the instrument cluster and Head-Up Display:

- ▷ Current audio source.
- ▷ Telephone redial.
- ▷ Activation of the voice control system.

Activating the list and entering a setting

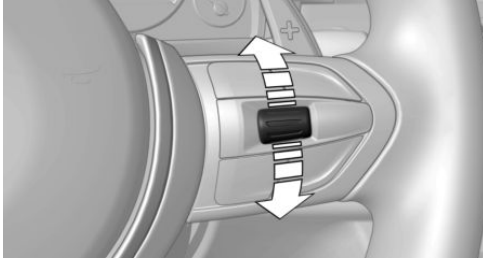

Turn the knurled wheel on the right-hand side of the steering wheel to activate the corresponding list.

1. Turn the knurled wheel and select the required setting.
2. Press the knurled wheel.

Display

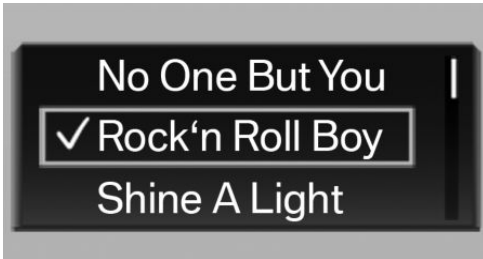

Depending on equipment, the list in the instrument cluster may differ from the illustration.

On-board computer

Principle

The on-board computer shows various vehicle-related data, such as average values, in the instrument cluster.

Calling up information on the information display

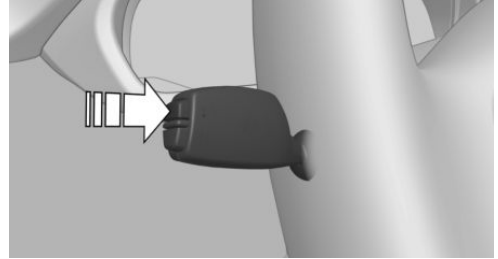

Press the button on the turn indicator lever.

Information is displayed on the information display in the instrument cluster. Further information is displayed by repeated pressing.

Overview of the information

Repeated pressing of the button on the turn indicator lever shows the following information on the information display:

- ▷ Range.
- ▷ Average consumption, fuel.
- ▷ Momentary consumption, fuel.
- ▷ Average speed.
- ▷ Date.
- ▷ Speed Limit Info.
- ▷ Depending on the equipment version, arrival time.
When route guidance is activated in the navigation system.
- ▷ Depending on the equipment version, distance to destination.
When route guidance is activated in the navigation system.
- ▷ Outside temperature and date.
When the digital speedometer is activated.

Selecting information

It is possible to select which information from the on-board computer can be called up on the information display in the instrument cluster.

Via iDrive:

1. "My Vehicle"
2. "iDrive settings"
3. "Displays"
4. "Instrument cluster"
5. Select required information.

Display in the information display

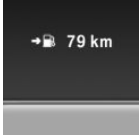

The information from the on-board computer is displayed in the information display in the instrument cluster.

Detailed information

Range

Displays the estimated range available with the remaining fuel.

The range is calculated based on your driving style over the last 30 km, 20 miles.

Average fuel consumption

The average consumption is calculated for the period during which the engine is running.

The average consumption is calculated on the route travelled since the on-board computer was last reset.

Average speed

The calculation of average speed ignores any stationary periods where the engine was switched off manually.

Resetting average values

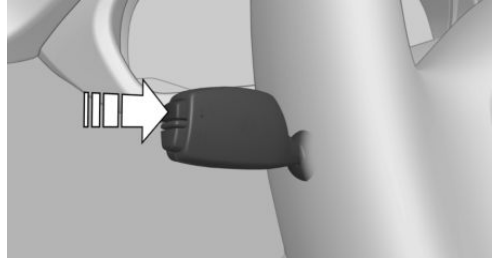

Press and hold the button on the turn indicator lever.

Distance to destination

Depending on the equipment version, the remaining distance to the destination is displayed if a destination was entered in the navigation system before the start of the journey.

The distance to the destination is automatically adopted.

Arrival time

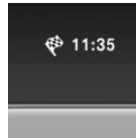

Depending on the equipment version, the estimated time of arrival is displayed if a destination was entered in the navigation system before the start of the journey.

A precondition is that the time is correctly set.

Speed Limit Info

For more information, see the Speed Limit Info chapter.

On-board computer on the Control Display

Principle

The on-board computer shows various data relating to the vehicle on the Control Display, such as average values.

General

Two kinds of on-board computer are available on the Control Display:

- ▶ "On-board computer": average values such as the consumption are displayed. The values can be reset individually.
- ▶ "Trip computer": values provide an overview of a particular route, and can be reset as often as required.

Calling up the on-board computer or trip computer

Via iDrive:

1. "My Vehicle"
2. "Driving information"
3. "On-board computer" or "Trip computer"



Resetting the on-board computer

Via iDrive:

1. "My Vehicle"
2. "Driving information"
3. "On-board computer"
4. "Consumption" or "Speed"
5. "OK"

Resetting the Trip computer

Via iDrive:

1. "My Vehicle"
2. "Driving information"
3. "Trip computer"
4. If necessary, tilt the Controller to the left.
 - ▶  "Reset": all values are reset.
 - ▶  "Reset automatically": all values are reset if the vehicle is at a standstill for approximately 4 hours.

Sport displays

General

On the Control Display the current values for performance and torque are shown if the vehicle is appropriately equipped.

Showing sport displays

Via iDrive:

1. "My Vehicle"
2. "Technology in action"
3. "Sport displays"

Speed warning

Principle

A speed limit can be set which triggers a warning when it is reached.

General

The warning is repeated if the vehicle speed exceeds the set speed limit again, after it has dropped below 5 km/h/3 mph.

Displaying, setting or altering the speed warning

Via iDrive:

1. "My Vehicle"
2. "Vehicle settings"
3. "Speed warning"
4. "Warning at:"
5. Turn the Controller until the desired speed is displayed.
6. Press the Controller.

Activating/deactivating the speed warning

Via iDrive:

1. "My Vehicle"
2. "Vehicle settings"
3. "Speed warning"
4. "Speed warning"
5. Press the Controller.

Setting the current speed as the speed warning

Via iDrive:

1. "My Vehicle"
2. "Vehicle settings"
3. "Speed warning"
4. "Select current speed"
5. Press the Controller.

Head-Up Display

Principle

The system projects important information, such as the speed, into the driver's field of vision.

The driver can register this information without having to divert attention from the road.

Overview

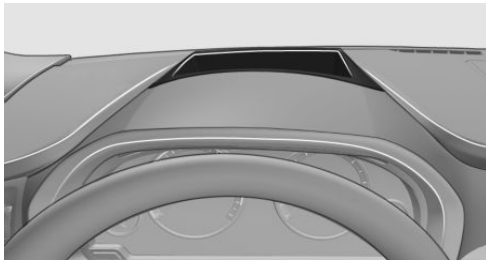

Switching on/off

1. "My Vehicle"
2. "iDrive settings"
3. "Displays"
4. "Head-up display"
5. "Head-up display"

Display

Standard view

The following information is displayed in the Head-Up Display:

- ▷ Speed.
- ▷ Navigation system.
- ▷ Check Control messages.
- ▷ Selection list from the instrument cluster.
- ▷ Driver Assistance Systems.

Some of this information is only shown briefly when needed.

M View

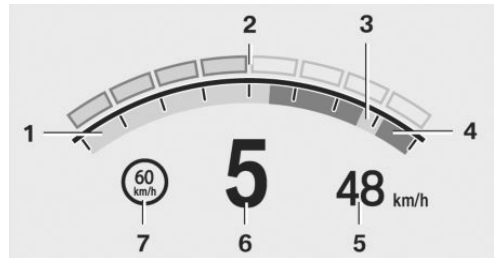

- 1 Current engine speed, highlighted
- 2 Shift Lights
- 3 Forewarning field, engine speed display
- 4 Red warning field, engine speed display
- 5 Speed
- 6 Gear display/warning messages
- 7 Speed Limit Info with overtaking restriction display

Activate M View:

Select displays in the Head-Up Display.

Selecting displays in the Head-Up Display

Via iDrive:

1. "My Vehicle"
2. "iDrive settings"
3. "Displays"
4. "Head-up display"
5. "Information displayed"
6. Select desired display in Head-Up Display.

Adjusting the brightness

The brightness is automatically adapted to the ambient light.

The base setting can be adjusted.

Via iDrive:

1. "My Vehicle"
2. "iDrive settings"
3. "Displays"
4. "Head-up display"
5. "Brightness"
6. Turn the Controller until the desired brightness is obtained.
7. Press the Controller.

The brightness of the Head-Up Display can also be adjusted with the instrument lighting if the low-beam headlights are switched on.

The setting is saved for the currently used profile.

Adjusting the height

Via iDrive:

1. "My Vehicle"
2. "iDrive settings"
3. "Displays"
4. "Head-up display"
5. "Height"

6. Turn the Controller until the desired height is obtained.

7. Press the Controller.

The setting is saved for the currently used profile.

The height of the Head-Up Display can also be saved with the memory function, see page 73.

Adjusting the rotation

The image of the Head-Up Display can be rotated around its axis.

Via iDrive:

1. "My Vehicle"
2. "iDrive settings"
3. "Displays"
4. "Head-up display"
5. "Rotation"
6. Turn the Controller until the desired setting is reached.
7. Press the Controller.

The setting is saved for the currently used profile.

Visibility of the display

The visibility of the display on the Head-Up Display can be affected by the following:

- ▷ Certain seat positions.
- ▷ Objects placed on the Head-Up Display cover.
- ▷ Sunglasses with certain polarisation filters.
- ▷ Wet road.
- ▷ Unfavourable lighting conditions.

If the picture is distorted, have the basic settings checked by a Service Partner of the manufacturer or another qualified Service Partner or a specialist workshop.

Follow the instructions for cleaning the Head-Up Display, see page 247.

Special windscreen

The windscreen constitutes part of the system.

The shape of the windscreen enables a sharp image to be projected.

A film in the windscreen prevents double images occurring.

For this reason, it is highly recommended for the special windscreen to be renewed by a Service Partner of the manufacturer or another qualified Service Partner or a specialist workshop if required.

Shift Lights

General

The display is on the Head-Up Display and in the instrument cluster.

Shift Lights in the instrument cluster

Display

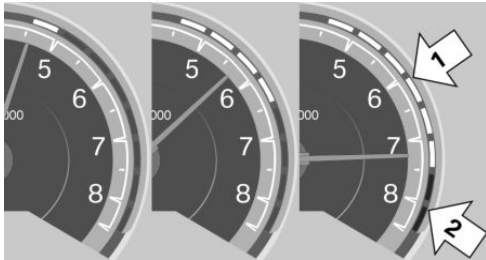

- ▷ Current engine speed is shown in the revolution counter.
- ▷ Arrow 1: yellow buttons illuminating successively indicate when a gearshift is due.
- ▷ Arrow 2: buttons illuminate red. Latest point to upshift.

When the maximum permitted engine speed is reached, the entire display flashes.

When the maximum engine speed is exceeded, the fuel supply is limited to protect the engine.

Shift Lights on the Head-Up Display

Switching on

Shift Lights are only displayed on the Head-Up Display in M view, see page 116.

1. Switch on Head-Up Display, see page 116.
2. "My Vehicle"
3. "iDrive settings"
4. "Displays"
5. "Head-up display"
6. "Information displayed"
7. "M view"

Display

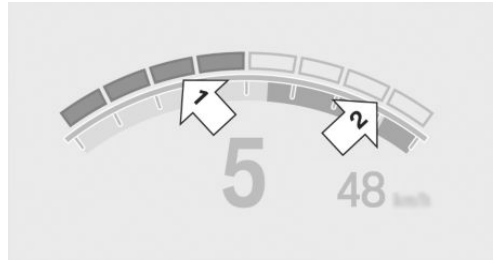

- ▷ Current engine speed is shown in the revolution counter.
- ▷ Arrow 1: yellow buttons illuminating successively indicate when a gearshift is due.
- ▷ Arrow 2: buttons illuminate red. Latest point to upshift.

When the maximum permitted engine speed is reached, the entire display flashes.

When the maximum engine speed is exceeded, the fuel supply is limited to protect the engine.

Vehicle status

General







The status can be displayed or actions performed for some systems.

Calling up the vehicle status

Via iDrive:

1. "My Vehicle"
2. "Vehicle status"

Overview of the information

- ▶  "Flat Tyre Monitor": status of the run-flat indicator, see page [133](#).
- ▶  "Tyre Pressure Monitor": status of the Tyre Pressure Monitor, see page [130](#).
- ▶ Resetting the Tyre Pressure Monitor, see page [130](#).
- ▶  "Engine oil level": electronic oil level check, see page [223](#).
- ▶  "Check Control": Check Control messages are stored in the background and can be shown on the Control Display. Displaying of saved Check Control messages, see page [105](#).
- ▶  "Service requirements": display of the service requirements, see page [109](#).
- ▶  "Teleservice Call": Teleservice Call.

Lights

Vehicle equipment

This chapter describes all standard, national and special equipment available for the model series. Therefore equipment which is not installed in your vehicle, for example on account of the selected optional equipment or the country specification, may also be described here. This also applies to safety-relevant functions and systems. Comply with the relevant laws and regulations when using the corresponding functions and systems.

Overview

Switch in the vehicle



The light switch element is located next to the steering wheel.

Symbol	Function
	Rear fog light.
	Automatic driving lights control. Adaptive light functions.
	Lights off. Daytime driving lights.
	Side lights.

Symbol	Function
	Low-beam headlights.
	Instrument lighting.

Side lights, low-beam headlights and parking light

General

Switch position:  ,  , 

If the driver door is opened when the ignition is switched off, the exterior lights are switched off automatically.

Side lights

Switch position:  

The vehicle is illuminated all round.

You should not leave the side lights on for longer periods of time, since the vehicle battery could discharge and you might not have enough power to start the engine.

To park, switch on the one-sided parking light, see page [120](#).

Low-beam headlights

Switch position: 

The low-beam headlights illuminate with the ignition switched on.

Parking light

Principle

The vehicle can be illuminated on one side.

Switching on

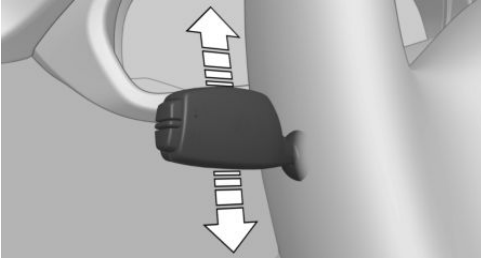

With radio ready state switched off, push the lever upwards or downwards beyond the resistance point.

Switching off

Press the lever back into the home position.

Welcome lights and headlight courtesy delay feature

Welcome lights

General

Depending on the equipment and the ambient brightness, individual light functions may be switched on briefly when the vehicle is unlocked.

Activating/deactivating

Switch position:  , 

Via iDrive:

1. "My Vehicle"
2. "Vehicle settings"
3. "Lights"
4. "Exterior lighting"
5. "Welcome lights"

The setting is saved for the currently used driver profile.

Headlight courtesy delay feature

General

If the high-beam headlights are activated with radio ready state switched off, the low-beam headlights remain on for a certain amount of time.

Setting the duration

Via iDrive:

1. "My Vehicle"
2. "Vehicle settings"
3. "Lights"
4. "Exterior lighting"
5. "Home lights"
6. Set the duration.

The setting is saved for the currently used driver profile.

Automatic driving lights control

Principle

Depending on ambient brightness, the system switches the low-beam headlights on or off automatically, for example in a tunnel, at twilight and in rain or snow.

General

The headlights may also come on when the sun is sitting low in a blue sky.

When emerging from tunnels in daylight, low-beam headlights are not switched off immediately, but only after approximately 2 minutes.

The low-beam headlights always remain on when the fog lights are switched on.

Activating

Switch position: 

The indicator lamp in the instrument cluster is illuminated if the low-beam headlights are switched on.

System limits

The automatic driving lights control is no substitute for your individual judgement of when it is necessary to switch on the lights.

The sensors are unable, for instance, to recognise fog or hazy weather. In such situations, switch on the lights manually to avoid any safety risk.

Daytime driving lights

General

Switch position: 0 , 

The daytime driving lights illuminate with the ignition switched on.

Activating/deactivating

In some countries daytime driving lights are compulsory, in which case the daytime driving lights cannot be deactivated.

Via iDrive:

1. "My Vehicle"
2. "Vehicle settings"
3. "Lights"
4. "Exterior lighting"
5. Select the desired setting.

The setting is saved for the currently used profile.

Adaptive Headlights

Principle

Adaptive Headlights is a variable headlight control system that makes it possible to illuminate the road surface responsively.

General

The beams from the headlights follow the road ahead on in response to the steering angle and other parameters.

So as not to dazzle oncoming vehicles, the Adaptive Headlights do not swivel to the driver's side when stationary.

Depending on equipment, the Adaptive Headlights comprise one or more systems:

- ▶ Variable light distribution, see page 122.

Activating

Switch position: 

The Adaptive Headlights are active when the engine is running.

Variable light distribution

Principle

The variable light distribution enables even better illumination of the carriageway.

General

The light distribution is automatically adapted to the speed.

City light

The illuminated area of the low-beam headlights is extended on the sides.

Motorway beam pattern

The illumination width of the low-beam headlights is expanded.

Adaptive headlight beam throw adjustment

The adaptive headlight beam throw adjustment compensates for acceleration and braking manoeuvres to prevent on-coming traffic from being dazzled and to ensure optimum illumination of the road.

High-beam assistance

Principle

The high-beam assistance detects other road users early on and activates or deactivates the high beam depending on the traffic situation.

General

High-beam assistance ensures that the high-beam headlights are switched on when the traffic situation allows. The high-beam headlights are not switched on by the system in the low speed range.

The system responds to light from oncoming traffic and traffic driving ahead of you, and to adequate lighting, for example in built-up areas.

The high-beam headlights can be switched on and off at any time as usual.

If the vehicle is equipped with dazzle-free high-beam assistance, the high-beam headlights are not switched off for oncoming vehicles; instead, the areas of the beam that would otherwise dazzle the oncoming traffic are masked off. In this case, the blue indicator lamp continues to illuminate.

Activating/deactivating

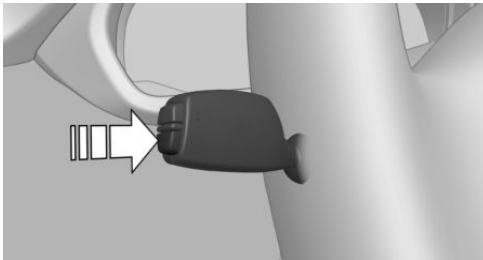

Switch position, depending on the equipment:



Press the button on the turn indicator lever.



The indicator lamp in the instrument cluster is illuminated if the low-beam headlights switched on.

The system will switch automatically between low-beam and high-beam headlights.



The blue indicator lamp in the instrument cluster illuminates if the high beam is switched on by the system.

The high-beam assistance is deactivated by manually switching the high beams on and off, see page 91.

To reactivate high-beam assistance, press the button on the turn indicator lever.

System limits

High-beam assistance cannot serve as a substitute for the driver's personal judgement of when to use the high-beam headlights. Thus, activate the dipped headlights manually in situations requiring such.

In the following situations, the system will not operate or its operation will be impaired and your intervention may be required:

- ▷ During extremely unfavourable weather conditions such as fog or heavy precipitation.
- ▷ When detecting poorly-lit road users such as pedestrians, cyclists or horseback riders or carts, and when trains or ships are close to the road, or when animals are crossing the road.
- ▷ On narrow bends, on steep hilltops or in depressions, when there is crossing traffic or if the view of oncoming vehicles on a motorway is obstructed.
- ▷ In poorly-lit towns and where there are very reflective signs.
- ▷ When the windscreen in front of the rear-view mirror is covered with condensation, dirt, stickers, labels, etc.

Fog lights

Rear fog light

Operating requirements

Before the rear fog light is switched on, the low-beam headlights must be switched on.

Switching on/off



Press the button.

The yellow indicator lamp illuminates if the rear fog light is switched on.

If automatic driving lights control, see page 121, has been activated, the low-beam headlights come on automatically when the rear fog light is switched on.

Left-hand/right-hand traffic

General

When driving in countries where vehicles drive on the opposite side of the road to your vehicle's country of registration, you will need to prevent your headlights from dazzling oncoming vehicles.

LED headlights

Light distribution of the headlights prevents the dipped-beam headlights from dazzling other road users even when driving in a country where vehicles drive on the other side of the road to your vehicle's country of registration.

Adaptive Headlights

When driving in countries which drive on the other side of the road to your vehicle's country of registration, do not drive with the switch in position . Otherwise, the variable light distribution may result in a blinding effect.

Instrument lighting

Operating requirements

The brightness can only be adjusted when the side lights or the low-beam headlights are switched on.

Adjusting



The brightness can be set using the knurled wheel.

Interior light

General

Depending on equipment, the interior light, the footwell lights, door entry lighting and the courtesy lighting are controlled automatically.

The brightness of some equipment is influenced by the knurled wheel for the instrument lighting.

Overview



- 1 Interior light
- 2 Reading lights

Switching the interior light on/off



Press the button.

To switch off permanently: press and hold the button for approximately 3 seconds.

Switching the reading lights on/off



Press the button.

Depending on the equipment version, there are reading lights located at the front and in the rear beside the interior light.

Ambient lighting

General

Depending on the equipment, the lighting for some of the interior lights can be set.

Selecting the colour scheme

Via iDrive:

1. "My Vehicle"
2. "Vehicle settings"
3. "Lights"
4. "Interior lighting"
5. "Ambient lighting"
6. Select the desired setting.

Adjusting the brightness

Depending on equipment, the brightness of the ambient light can be set using the knurled wheel for the instrument lighting or on the Control Display.

Via iDrive:

1. "My Vehicle"
2. "Vehicle settings"
3. "Lights"
4. "Interior lighting"
5. "Brightness"
6. Adjusting the brightness.

Safety

Vehicle equipment

This chapter describes all standard, national and special equipment available for the model series. Therefore equipment which is not installed in your vehicle, for example on account

of the selected optional equipment or the country specification, may also be described here. This also applies to safety-relevant functions and systems. Comply with the relevant laws and regulations when using the corresponding functions and systems.

Airbags

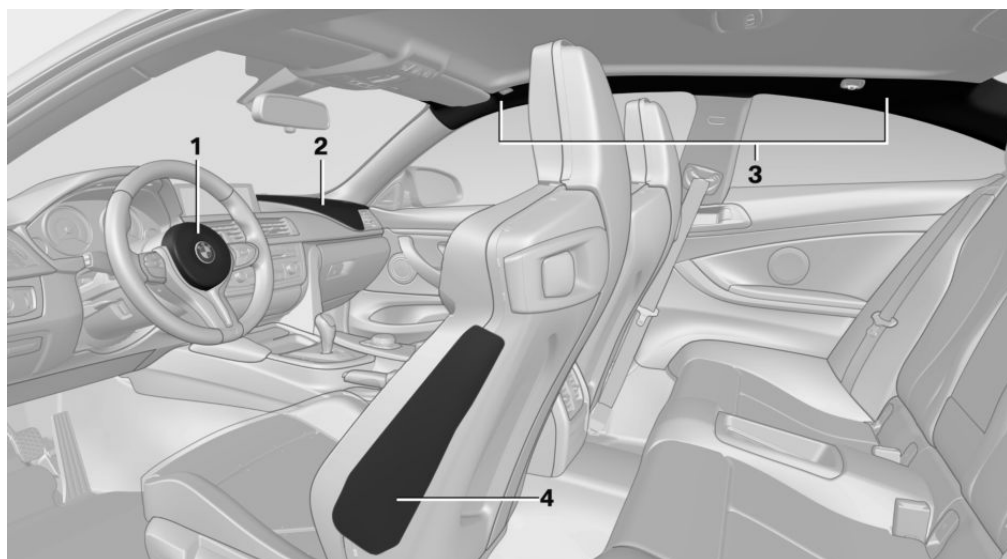

1 Front airbag, driver

2 Front airbag, front passenger

3 Head airbag

4 Side airbag

Front airbags

Front airbags protect the driver and front passenger in the event of a head-on collision where the protection of the seat belts alone would no longer be sufficient.

Side airbag

In a side-on crash, the side airbag supports the body at the side in the chest and pelvic area.

Head airbag

The head airbag supports the head in the event of a side-on crash.

Protective effect

Airbags are not activated in every collision, for example in minor accidents and rear-end collisions.

Notes on achieving optimum airbag effectiveness



WARNING

If the seat position is wrong or the deployment area of the airbag is restricted, the airbag system cannot provide the intended protection, or may cause additional injuries when it deploys. There is a danger of injury or even death. Observe the following to achieve optimum protective effect: ◀

- ▶ Keep your distance from the air bags.
- ▶ Always grip the steering wheel on the steering wheel rim. Place your hands in the 3 o'clock and 9 o'clock positions to minimise the risk of injury to hands or arms when the airbag deploys.
- ▶ Make sure that vehicle occupants keep their head away from the side airbag.
- ▶ Make sure that the front-seat passenger is sitting correctly, in other words with feet or legs in the footwell, not resting them on the dashboard.
- ▶ Do not position any other persons, animals or objects between the air bags and persons.
- ▶ Keep the dashboard and windscreen in the area of the passenger's side free, for example do not attach adhesive foil or covers and do not fit brackets for navigation devices or mobile telephones.
- ▶ Do not attach anything to the airbag covers with adhesive; never cover them or modify them in any way.
- ▶ Do not use the front airbag cover on the front passenger's side as a tray.
- ▶ Covers, seat covers, cushions or other objects not specifically suitable for seats with integral side air bags must not be fitted to the front seats.
- ▶ Do not hang items of clothing such as coats or jackets over the backrests.

- ▶ Do not modify individual components of the system or its wiring in any way. This also applies to the covers of the steering wheel, the dashboard and seats.
- ▶ Do not dismantle the airbag system.

Even if all these notes are complied with, depending on the circumstances in which an accident occurs, certain injuries as a result of contact with the airbag cannot be entirely ruled out.

The noise caused by the deployment of an airbag may lead to temporary hearing loss for vehicle occupants sensitive to noise.

Operational readiness of the airbag system

Safety notes



WARNING

Individual components of the airbag system can be hot after airbag deployment. There is a danger of injury. Do not touch individual components. ◀



WARNING

Work carried out incorrectly can lead to a failure, a malfunction or accidental deployment of the airbag system. If there is a malfunction, the airbag system might not deploy as intended in an accident, in spite of the accident being of the appropriate severity. There is a danger of injury or even death. Have the airbag system tested, repaired or removed and disposed of by a Service Partner of the manufacturer or another qualified Service Partner or a specialist workshop. ◀

Correct function



When the ignition is switched on, the warning lamp in the instrument cluster briefly illuminates in order to show the operational readiness of the entire airbag system and the belt tensioner.

Airbag system malfunction

- ▷ Warning light does not illuminate after the ignition is switched on.
- ▷ Warning lamp is permanently illuminated.

Not for Australia/New Zealand: Key switch for front passenger airbags

General

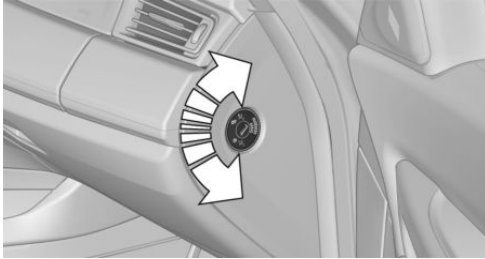

The front and side airbags for the front passenger can be deactivated and reactivated using the integrated key from the remote control.

Deactivating the front passenger airbags



1. Insert the key and press inwards where necessary.
2. While the key is pressed inwards, turn it to the OFF position as far as it will go. Once the stop position has been reached, remove the key.
3. Make sure that the key switch is in the end position so that the airbags are deactivated.

The front passenger airbags are deactivated. The driver's airbags remain active.

If a child restraint system is no longer fitted in the front passenger seat, reactivate the front

passenger airbags so that they are triggered as intended in the event of an accident.

The airbag condition is displayed on the front passenger airbag indicator lamp, see page 128.

Activating the front passenger airbags



1. Insert the key and press inwards where necessary.
2. While the key is pressed inwards, turn it to the ON position as far as it will go. Once the stop position has been reached, remove the key.
3. Make sure that the key switch is in the end position so that the airbags are activated.

The front passenger airbags are reactivated and can deploy correctly if the need arises.

Indicator lamp for front passenger airbags



The indicator lamp for the front passenger airbags shows the operating status of the front passenger airbags.

After switching on the ignition, the light illuminates briefly and then shows whether the airbags are activated or deactivated.



- ▷ When front passenger airbags are deactivated, the indicator lamp remains illuminated.
- ▷ When front passenger airbags are activated, the indicator lamp is not illuminated.

Active pedestrian protection

Principle

With the active pedestrian protection system, the bonnet is raised if the vehicle's front end collides with a pedestrian. Sensors underneath the bumper are used for detection. This provides additional deformation space underneath the bonnet for the subsequent head impact.

Safety notes



WARNING

The system can trigger inadvertently if contact is made with individual components of the hinges and bonnet locks. There is a danger of injury or damage to property. Do not touch individual components of the hinges and bonnet locks. ◀



WARNING

Changes to the pedestrian protection system can lead to a failure, a malfunction or accidental triggering of the pedestrian protection system. There is a danger of injury or even death. Do not modify individual components of the pedestrian protection system or its wiring in any way. Do not dismantle the system. ◀



WARNING

Work carried out incorrectly can lead to a failure, a malfunction or accidental triggering of the system. If there is a malfunction, the system might not trigger as intended in an accident, in spite of the accident being of the appropriate severity. There is a danger of injury or even death. Have the system tested, re-

paired or removed and disposed of by a Service Partner of the manufacturer or another qualified Service Partner or a specialist workshop. ◀



WARNING

If the system has triggered or is damaged, its functions will be restricted, or will no longer work at all. There is a danger of injury or even death.

If the system has triggered or is damaged, have it checked and renewed at a Service Partner of the manufacturer or another qualified Service Partner or a specialist workshop. ◀



NOTE

Opening the bonnet when the pedestrian protection system has triggered can result in damage to the bonnet or the pedestrian protection. There is a danger of damage to property. Do not open the bonnet after the Check Control message is displayed. Have a check performed by a Service Partner of the manufacturer or another qualified Service Partner or a specialist workshop. ◀

System limits

The active pedestrian protection system is only triggered at speeds between approx. 20 km/h, approx. 12 mph and 55 km/h, approx. 34 mph.

For safety reasons, the system may also trigger in rare instances where impact with a pedestrian cannot be excluded beyond all doubt, for example:

- ▷ Collision with a skip or a boundary post.
- ▷ Collision with animals.
- ▷ Stone impact.
- ▷ Driving into a snow drift.

Malfunction



A Check Control message is shown.

The system has been triggered or is faulty. Immediately have the system checked by a Service Partner of the manufacturer or another qualified Service Partner or a specialist workshop.

Tyre Pressure Monitor TPM

Principle

The system monitors the tyre inflation pressure in the four fitted tyres. The system warns if the tyre inflation pressure in one or more tyres has fallen considerably.

General

Sensors in the tyre valves measure the tyre inflation pressure and, depending on the model, the tyre temperature.

To operate the system, also follow the other information and notes under tyre inflation pressure, see page 207.

Operating requirements

The following requirements must be met for the system, otherwise reliable signalling of a loss of tyre inflation pressure is not ensured:

- ▷ After every tyre or wheel change, a reset must be carried out with the correct tyre inflation pressure.
- ▷ A reset must be carried out after the tyre inflation pressure has been adjusted to a new value.
- ▷ Wheels with TPM wheel electronics.

Status display

Current status

The status of the system for example whether the system is active, can be shown on the Control Display.

Via iDrive:

1. "My Vehicle"
2. "Vehicle status"
3.  "Tyre Pressure Monitor"

The current status is displayed.

Tyre statuses

General

The tyre and system status is denoted by the wheel colour and text on the Control Display.

All wheels green

System is active and is using the tyre inflation pressures saved during the last reset for the warning.

One to four wheels yellow

There is a flat tyre or major loss of tyre inflation pressure in the tyres shown.

Wheels grey

Tyre pressure losses cannot be detected.

Possible causes:

- ▷ Malfunction.
- ▷ System reset is performed.

Additional information

The current tyre inflation pressures and, depending on the model, tyre temperatures are also displayed in the status Control Display. The values shown are current values and may change due to the effects of driving conditions or weather conditions.

Performing a reset

Via iDrive:

1. "My Vehicle"
2. "Vehicle status"
3.  "Tyre Pressure Monitor"
4. Start the engine but do not drive off.

5. Reset the tyre inflation pressure: "Perform reset".
6. Drive off.

The wheels are shown grey and the following appears on the display: "Resetting Tyre Pressure Monitor...".

After driving for a short time over 30 km/h, 19 mph the set tyre pressures are accepted as target values. The reset is completed automatically during the journey.

After a successfully concluded reset, the wheels are shown in green on the Control Display and "Tyre Pressure Monitor active. See label for recommended pressures." is shown.

You can interrupt your journey at any time. Reset resumes automatically when you continue your journey.

Messages

General

Dynamic Stability Control DSC will be activated if necessary as soon as a message for low tyre inflation pressure appears.

Safety note



WARNING

A damaged normal tyre with too low tyre inflation pressure, or no pressure at all impairs driving properties, for example steering and braking. There is a danger of accidents. Do not continue driving. Repair the flat tyre or replace the wheel. ◀

If a tyre inflation pressure test is required

Message

A symbol with a Check Control message is shown on the Control Display.

Symbol Possible cause



The System has detected a wheel change, but no reset has been run. No reset has been performed on to the system. The system uses the tyre inflation pressures saved during the last reset for the warning. The tyre was not inflated properly.



The tyre inflation pressure has dropped compared to the last reset.

Measure

1. Check the tyre inflation pressure and adjust as necessary.
2. Perform a reset of the system.

If the tyre inflation pressure is too low

Message



A yellow warning lamp is illuminated in the instrument cluster.

In addition, a symbol with a Check Control message is shown on the Control Display.

Symbol Possible cause



There has been a loss of tyre inflation pressure. No reset has been performed on to the system. The system uses the tyre inflation pressures saved during the last reset for the warning.

Measure

1. Reduce speed and continue driving at moderate speed. Do not exceed a speed of 130 km/h, 80 mph any longer.
2. At the next opportunity, for example filling station, check the tyre inflation pressure in all four tyres and correct if necessary.
3. Perform a reset of the system.

If there is a significant loss of tyre inflation pressure

Message



A yellow warning lamp is illuminated in the instrument cluster.

In addition, a symbol with the affected tyre is shown in a Check Control message on the Control Display.

Symbol	Possible cause
	<p>There is a flat tyre or substantial loss of tyre inflation pressure.</p> <p>No reset has been performed on to the system. The system uses the tyre inflation pressures saved during the last reset for the warning.</p>



There is a flat tyre or substantial loss of tyre inflation pressure.

No reset has been performed on to the system. The system uses the tyre inflation pressures saved during the last reset for the warning.

Measure

Reduce your speed and carefully stop the vehicle. Avoid violent or sudden braking and steering manoeuvres.

What to do in the event of a flat tyre

1. Identify the damaged tyre.

To do this, check the air pressure in all four tyres, for example using the tyre inflation pressure indicator of a flat tyre kit.

If all four tyres are inflated to the correct tyre inflation pressures, the Tyre Pressure Monitor might not have been reset. Perform a reset.

If it is not possible to identify tyre damage, contact a Service Partner of the manufacturer or another qualified Service Partner or a specialist workshop.

2. Repair the flat tyre, for example using a flat tyre kit or by changing the wheel.

The use of sealant, for example a flat tyre kit, can damage the TPM wheel electronics. In this case, have the electronics replaced at the next opportunity.

System limits

Temperature

The tyre inflation pressure depends on the temperature of the tyre.

The tyre inflation pressure increases as the tyre temperature increases, for example during driving or due to exposure to sunlight.

Tyre inflation pressure decreases if the tyre temperature drops.

Through this behaviour, a warning may be triggered if there are major temperature drops, due to the given warning limits.

Sudden loss of tyre inflation pressure

No warning can be given by the system of extreme, sudden tyre failure caused by external factors.

Reset not carried out

The system will not function correctly if a reset has not been carried out, for example, a flat tyre is reported in spite of the correct tyre pressure.

Malfunction



The yellow warning lamp flashes and is then illuminated continuously. A Check Control message is shown. Tyre pressure losses cannot be detected.

In these cases:

- ▷ A wheel without TPM wheel electronics is fitted: have the wheels checked if necessary.
- ▷ Malfunction: have the system checked.
- ▷ The system was unable to complete the reset. Perform a system reset again.
- ▷ Fault due to systems or devices with the same frequency: the system is automatically reactivated upon leaving the field of interference.

Runflat indicator RPA

Principle

The system identifies a loss of tyre inflation pressure by comparing the rotational speeds of the individual wheels during the journey.

If a tyre loses inflation pressure, its diameter changes. This in turn alters the rotational speed of the corresponding wheel. The difference will be detected and reported as a flat tyre.

The system does not measure the tyre inflation pressure as such.

Operating requirements

The following requirements must be met for the system, otherwise reliable signalling of a loss of tyre inflation pressure is not ensured:

- ▶ After every tyre or wheel change, an initialisation must be carried out with the correct tyre inflation pressure.
- ▶ An initialisation must be carried out after the tyre inflation pressure has been adjusted to a new value.

Status display

The current status of the runflat indicator can be shown, for example whether the RPA is active.

Via iDrive:

1. "My Vehicle"
2. "Vehicle status"
3.  "Flat Tyre Monitor"

The status is displayed.

Initialisation required

An initialisation must be performed in the following situations:

- ▶ After adjusting the tyre inflation pressure.
- ▶ After a tyre or wheel change.

Performing initialisation

On initialisation, the current tyre pressures are saved as a reference for detection of a flat tyre. The initialisation is started by confirming the correct tyre inflation pressures.

When driving with snow chains fitted, do not initialise the system.

Via iDrive:

1. "My Vehicle"
2. "Vehicle status"
3.  "Flat Tyre Monitor"
4. Start the engine but do not drive off.
5. Start the initialisation: "Perform reset"
6. Drive off.

Initialising is completed during the journey; this process can be interrupted at any time.

Initialising resumes automatically when you continue your journey.

Messages

Safety note



WARNING

A damaged normal tyre with too low tyre inflation pressure, or no pressure at all impairs driving properties, for example steering and braking. There is a danger of accidents. Do not continue driving. Repair the flat tyre or replace the wheel. ◀

Flat tyre message



A yellow warning lamp is illuminated in the instrument cluster.

In addition, a symbol with a Check Control message is shown on the Control Display.

Symbol	Possible cause
	There is a flat tyre or substantial loss of tyre inflation pressure.

Measure

1. Reduce your speed and carefully stop the vehicle. Avoid violent or sudden braking and steering manoeuvres.
2. Determine which wheel is damaged. To do this, check the air pressure in all four tyres, for example using the tyre inflation pressure indicator of a flat tyre kit. If all tyres are inflated to the correct tyre inflation pressures, the runflat indicator might not have been initialised. In this case initialise the system.
3. Repair the flat tyre, for example using a flat tyre kit or by changing the wheel.

System limits

In the following situations, the system could be slow to respond or operate incorrectly:

- ▷ A natural, even loss of tyre inflation pressure in all four tyres that occurs over time is not detected. Consequently, check the tyre inflation pressure at regular intervals.
- ▷ No warning can be given in the event of sudden tyre failure caused by external factors.
- ▷ If the system has not been initialised.
- ▷ When driving on snow-covered or slippery surfaces.
- ▷ Dynamic driving style: drive wheels slipping, high lateral acceleration.
- ▷ Driving with snow chains.

Intelligent Safety

Principle

Intelligent Safety enables Driver Assistance Systems to be operated centrally.

Depending on equipment, Intelligent Safety consists of one or more systems which can help to avoid the risk of a collision. Each time the engine is started via the start/stop button, these systems are automatically active:

- ▷ Front-end collision with light braking function, see page 135.
- ▷ Person warning, see page 138.

Safety notes



WARNING

The system does not release you from your personal responsibility to assess the visibility conditions and traffic situation correctly. There is a danger of accidents. Adapt your driving style to the traffic conditions. Observe the traffic situation and intervene actively if the situation warrants it. ◀



WARNING

Displays and warnings do not relieve you of personal responsibility. System limitations can mean that warnings or system responses are not issued or are issued too late, incorrectly, or without justification. There is a danger of accidents. Adapt your driving style to the traffic conditions. Observe the traffic situation and intervene actively if the situation warrants it. ◀



WARNING

Due to system limitations, there may be malfunctions of individual functions when tow starting/towing with activated Intelligent Safety Systems. There is a danger of accidents. Switch off all Intelligent Safety Systems before tow-starting/towing. ◀

Overview

Button in the vehicle





Intelligent Safety button

Camera

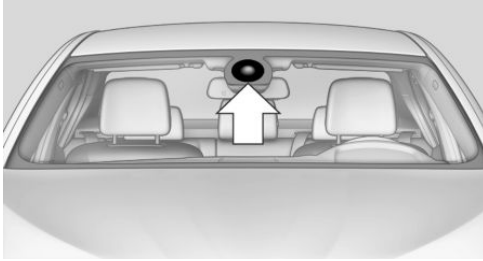

The camera is located on the front side of the rear-view mirror.

Keep the windscreen clean and clear in the area in front of the rear-view mirror.

Switching on/off

The Intelligent Safety Systems are active automatically at the start of each journey.



Press button: the systems are switched off again. The LED is extinguished.

Press button again: the systems are switched on. LED is illuminated.

Intelligent Safety Settings can be adjusted on the Control Display.

Front-end collision with light braking function

Principle

The system can help avoid accidents. If an accident cannot be avoided, the system helps to reduce the collision speed.

The system warns of the possible risk of collision and brakes automatically, as necessary.

The automatic braking intervention is done with limited force and duration.

The system is controlled by a camera in the area of the rear-view mirror.

The front-end collision warning is also available if the Cruise Control is disabled.

When deliberately approaching a vehicle, the front-end collision warning and braking intervention are activated later to avoid unjustified system responses.

General

The system will provide a warning from approximately 5 km/h, approximately 3 mph in two stages of any risk of collision with vehicles. The timing of these warnings may vary depending on the current driving situation.

Braking intervention is permitted up to a speed of approximately 60km/h, 35 mph.

Detection range

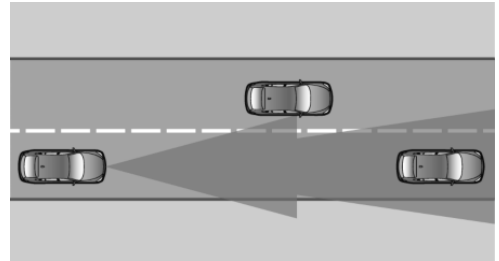

Objects detected by the system are taken into account.

Safety notes



WARNING

The system does not release you from your personal responsibility to assess the visibility conditions and traffic situation correctly. There is a danger of accidents. Adapt your driving style to the traffic conditions. Observe the traffic situation and intervene actively if the situation warrants it. ◀

**WARNING**

Displays and warnings do not relieve you of personal responsibility. System limitations can mean that warnings or system responses are not issued or are issued too late, incorrectly, or without justification. There is a danger of accidents. Adapt your driving style to the traffic conditions. Observe the traffic situation and intervene actively if the situation warrants it. ◀

**WARNING**

Due to system limitations, there may be malfunctions of individual functions when tow starting/towing with activated Intelligent Safety Systems. There is a danger of accidents. Switch off all Intelligent Safety Systems before tow-starting/towing. ◀

Overview

Button in the vehicle



Intelligent Safety button

Camera

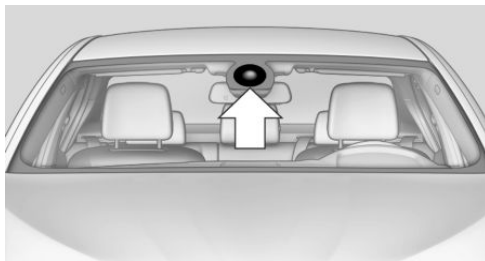

The camera is located on the front side of the rear-view mirror.

Keep the windscreen clean and clear in the area in front of the rear-view mirror.

Switching on/off

Switching on automatically

The system is automatically activated at the start of each journey.

Switching off



Press the button: the system is switched off. The LED is extinguished.

Press the button again: the system is switched on. LED is illuminated.

Setting the warning time

The warning time can be set.

Via iDrive:



1. "My Vehicle"
2. "Vehicle settings"
3. "Intelligent Safety"
4. "Warning point"
5. Select the desired setting.

The selected time is saved for the currently used driver profile.

Warning with braking function

Display

If there is a risk of collision with a detected vehicle, a warning symbol is shown in the instrument cluster and in the Head-Up Display.

Symbol	Measure
	Symbol illuminates red: advance warning. Brake and increase the distance.
	Symbol flashes red and an acoustic signal sounds: acute warning. Brake and perform an evasive manoeuvre, if necessary.

Advance warning

An advance warning is shown, for example if a danger of collision is anticipated or there is a very short distance to a vehicle ahead.

The driver must intervene personally if there is an advance warning.

Acute warning with braking function

An acute warning is shown in the event of an immediate collision if the vehicle approaches an object with high differential speed.

The driver must intervene personally if there is an advance warning. If necessary, the driver is assisted by slight automatic brake intervention if there is a risk of collision.

An acute warning can be triggered even without a previous advance warning.

Brake intervention

The warning prompts the driver to intervene actively. Maximum braking force is used during a warning. In order for braking force support to be used, it is necessary for the brake to be pressed sufficiently quickly and powerfully. The system can also assist by applying the brakes lightly if there is the risk of a collision.

The vehicle can be braked at low speed until it comes to a stop.

Manual gearbox: when the vehicle is braked to a stop, the engine may shut off.

The brakes are only applied if driving stability has not been impaired, for example by deactivation of Dynamic Stability Control DSC.

Braking can be discontinued either by depressing the accelerator pedal or by actively moving the steering wheel.

The detection of objects can be restricted. Take into account the detection range limits and the functional restrictions.

System limits

Safety note



WARNING

The system may respond not at all, too late, incorrectly, or without justification due to limits of the system. There is a danger of accident or damage to property. Observe the information on the system limits and intervene actively if necessary. ◀

Detection range

The detection ability of the system is limited.

For this reason, the system may fail to respond or only respond after a delay.

It is possible that the following are not detected:

- ▷ Slow-moving vehicle when approaching at high speed.
- ▷ Vehicles suddenly cutting in or braking heavily.
- ▷ Vehicles with unusual rear appearance.
- ▷ Two-wheeled vehicles ahead.

Functional restrictions

The function may be restricted in the following situations, for example:

- ▷ In thick fog, wet conditions or snow.

- ▷ On sharp bends.
- ▷ When Driving Stability Control Systems are limited or deactivated, for example DSC OFF.
- ▷ If the field of view of the camera in the mirror is soiled or covered.
- ▷ Up to 10 seconds after starting the engine using the start/stop button.
- ▷ During the camera calibration process immediately after vehicle delivery.
- ▷ When there is sustained glare effect due to oncoming light, for example the sun is low in the sky.

Sensitivity of the warnings

The greater the sensitivity of the warning settings, for example warning time, the more warnings will be displayed. As a result, there may be an increased number of premature or unjustified warnings and reactions.

Person warning with City light braking function

Principle

The system can help to avoid accidents with pedestrians.

The system warns of the possible risk of collision with pedestrians in the urban speed range and provides assistance with a light braking function.

The system is controlled by the camera in the area of the rear-view mirror.

General

Provided that the light conditions are sufficiently bright, the system operates and issues warnings from approximately 10 km/h, approximately 6 mph up to approximately 60 km/h, approximately 35 mph if there is a risk of collision with pedestrians and provides assistance by briefly applying the brakes before a collision.

Persons are taken into account if they are located within the detection range of the system.

Detection range

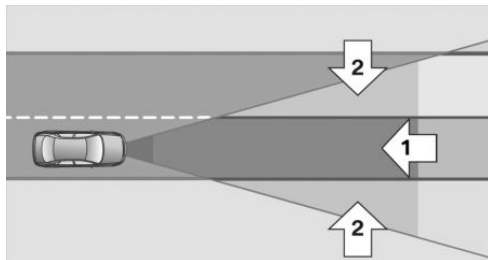

The detection zone in front of the vehicle consists of two parts:

- ▷ Central zone, arrow 1, directly in front of the vehicle.
- ▷ Extended zone, arrow 2, to the right and left of central area.

There is a risk of collision if persons are in the central zone. A warning is only given of persons in the extended zone if they are moving towards the central zone.

Safety notes



WARNING

The system does not release you from your personal responsibility to assess the visibility conditions and traffic situation correctly. There is a danger of accidents. Adapt your driving style to the traffic conditions. Observe the traffic situation and intervene actively if the situation warrants it. ◀



WARNING

Displays and warnings do not relieve you of personal responsibility. System limitations can mean that warnings or system responses are not issued or are issued too late, incorrectly, or without justification. There is a danger of accidents. Adapt your driving style to the traffic conditions. Observe the traffic situa-

tion and intervene actively if the situation warrants it. ◀



WARNING

Due to system limitations, there may be malfunctions of individual functions when tow starting/towing with activated Intelligent Safety Systems. There is a danger of accidents. Switch off all Intelligent Safety Systems before tow-starting/towing. ◀

Overview

Button in the vehicle



Intelligent Safety button

Camera

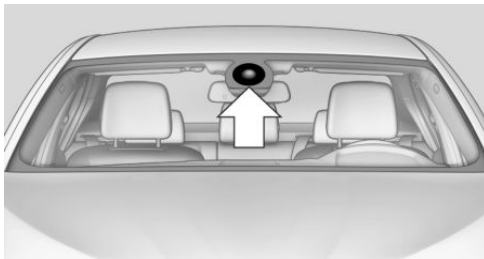

The camera is located on the front side of the rear-view mirror.

Keep the windscreen clean and clear in the area in front of the rear-view mirror.

Switching on/off

Switching on automatically

The system is automatically activated at the start of each journey.

Switching off



Press button: the systems are switched off again. The LED is extinguished.

Press button again: the systems are switched on. LED is illuminated.

Warning with braking function

Display

If there is a risk of collision with a detected person, a warning symbol is shown in the instrument cluster and in the Head-Up Display.



A red symbol is displayed and an acoustic warning sounds.

Take action yourself immediately, by braking or swerving.

Brake intervention

The warning prompts the driver to intervene actively. Maximum braking force is used during a warning. In order for braking force support to be used, it is necessary for the brake to be pressed sufficiently quickly and powerfully. The system can also assist by applying the brakes lightly if there is the risk of a collision. The vehicle can be braked at low speed until it comes to a stop.

Manual gearbox: when the vehicle is braked to a stop, the engine may shut off.

The brakes are only applied if driving stability has not been impaired, for example by deactivation of Dynamic Stability Control DSC.

Braking can be discontinued either by depressing the accelerator pedal or by actively moving the steering wheel.

The detection of objects can be restricted. Take into account the detection range limits and the functional restrictions.

System limits

Safety note



WARNING

The system may respond not at all, too late, incorrectly, or without justification due to limits of the system. There is a danger of accident or damage to property. Observe the information on the system limits and intervene actively if necessary. ◀

Detection range

The detection capacity of the camera is limited.

As a result, the system may fail to give warnings or may give warnings late.

It is possible that the following are not detected:

- ▷ Partially concealed pedestrians.
- ▷ Pedestrians who are not detected as such because of the viewing angle or outline.
- ▷ Pedestrians outside the detection range.
- ▷ Pedestrians less than approximately 80 cm, 32 in tall.

Functional restrictions

The function may be restricted or not available in the following situations, for example:

- ▷ In thick fog, wet conditions or snow.
- ▷ On sharp bends.
- ▷ If vehicle stability control systems are deactivated, for example DSC OFF.
- ▷ If the field of view of the camera or the windscreen is dirty or covered.
- ▷ Up to 10 seconds after starting the engine using the start/stop button.

- ▷ During the camera calibration process immediately after vehicle delivery.
- ▷ When there is sustained glare effect due to oncoming light, for example the sun is low in the sky.
- ▷ In the dark.

Lane Departure Warning

Principle

The Lane Departure Warning issues a warning if the vehicle leaves its lane on a road with lane markings.

General

Depending on the country version, the system issues a warning at speeds between 55 km/h, 35 mph and 70 km/h, 45 mph.

When switching on the system below this speed, a message is displayed in the instrument cluster.

Warnings are issued by means of a steering wheel vibration. The timing of this warning may vary depending on the current driving situation.

The system does not issue a warning if the driver indicates before leaving the driving lane.

Safety notes



WARNING

The system does not release you from your personal responsibility to estimate the course of the road and traffic situation. There is a danger of accidents. Adapt your driving style to the traffic conditions. Observe the traffic situation and intervene actively if the situation warrants it. In the event of a warning, do not move the steering wheel with unnecessary force. ◀

**WARNING**

Displays and warnings do not relieve you of personal responsibility. System limitations can mean that warnings or system responses are not issued or are issued too late, incorrectly, or without justification. There is a danger of accidents. Adapt your driving style to the traffic conditions. Observe the traffic situation and intervene actively if the situation warrants it. ◀

Overview**Button in the vehicle**

Lane Departure Warning

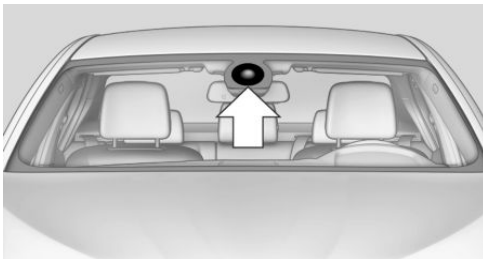
Camera

The camera is located on the front side of the rear-view mirror.

Keep the windscreen clean and clear in the area in front of the rear-view mirror.

Switching on/off

Press the button.

- ▷ On: LED is illuminated.
- ▷ Off: LED is extinguished.

The setting is saved for the currently used driver profile.

Display in the instrument cluster

- ▷ Lines: the system is activated.
- ▷ Arrows: at least one lane boundary line has been detected and warnings can be issued.

Output of the warning**When leaving the lane**

If the vehicle leaves the lane and a lane marking is detected, the steering wheel vibrates.

If the turn indicator is set before changing lanes, no warning is issued.

Cancellation of the warning

The warning is interrupted in the following situations:

- ▷ Automatically after approximately 3 seconds.
- ▷ On returning to the correct lane.
- ▷ When braking heavily.
- ▷ On indicating.

System limits**Safety note****WARNING**

The system may respond not at all, too late, incorrectly, or without justification due to limits of the system. There is a danger of accident or damage to property. Observe the information on the system limits and intervene actively if necessary. ◀

Functional restrictions

The function may be restricted in the following situations, for example:

- ▷ In thick fog, wet conditions or snow.
- ▷ With missing, worn, poorly visible, merging/separating or ambiguous boundary lines, for example in areas where there are road works.
- ▷ If boundary lines are covered by snow, ice, dirt or water.
- ▷ On sharp bends or narrow roads.
- ▷ If the boundary lines are not white.
- ▷ If boundary lines are obscured.
- ▷ If the vehicle is moving too close to the vehicle ahead.
- ▷ With bright oncoming light.
- ▷ When the windscreen in front of the rear-view mirror is covered with condensation, dirt, stickers, labels, etc.
- ▷ During the camera calibration process immediately after vehicle delivery.

Lane Change Warning

Principle

The Lane Change Warning detects vehicles in the blind spot, or if vehicles are approaching from behind in the adjacent lane. A warning is issued in various gradations in these situations.

General

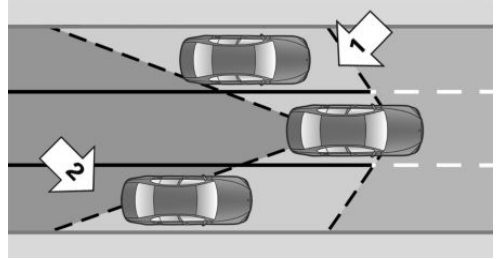

Two radar sensors in the rear bumper monitor the area behind and beside the vehicle as of approximately 20 km/h, approximately 12 mph.

In some equipment configurations, the radar sensors are active from approximately 50 km/h, approximately 30 mph.

The system indicates when vehicles are in the blind spot, arrow 1, or are approaching from the rear in an adjacent lane, arrow 2.

The light in the exterior mirror housing illuminates at a dimmed level.

Before changing lanes with the turn indicator switched on, the system issues a warning in the above situations.

The light in the exterior mirror housing flashes and the steering wheel vibrates.

Safety notes



WARNING

The system does not release you from your personal responsibility to assess the visibility conditions and traffic situation correctly. There is a danger of accidents. Adapt your driving style to the traffic conditions. Observe the traffic situation and intervene actively if the situation warrants it. ◀



WARNING

Displays and warnings do not relieve you of personal responsibility. System limitations can mean that warnings or system responses are not issued or are issued too late, incorrectly, or without justification. There is a dan-

ger of accidents. Adapt your driving style to the traffic conditions. Observe the traffic situation and intervene actively if the situation warrants it. ◀

Overview

Button in the vehicle



Lane Change Warning

Radar sensors

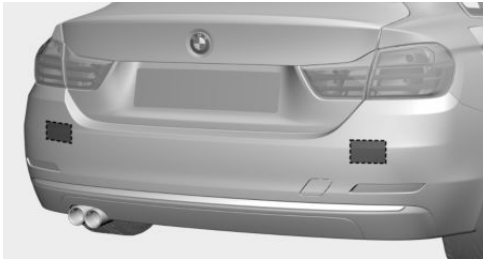

The radar sensors are located in the rear bumper.

Switching on/off



Press the button.

- ▶ On: LED is illuminated.
- ▶ Off: LED is extinguished.

The setting is saved for the currently used driver profile.

Display

Light in the exterior mirror housing

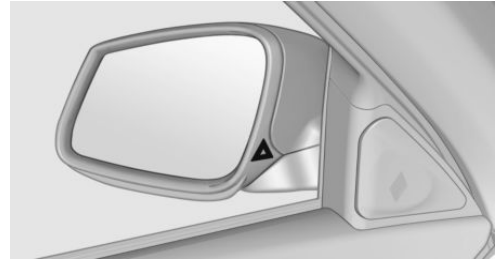

Advance warning

The dimmed light in the exterior mirror housing indicates when vehicles are in the blind spot or are approaching from the rear.

Acute warning

If the turn indicator is set while a vehicle is in the critical area, the steering wheel vibrates briefly and the light in the exterior mirror housing flashes brightly.

The warning is terminated when the turn signal is cancelled or the other vehicle has left the critical area.

Brief flash

A brief flash of the light when unlocking the vehicle is used as a self-test of the system.

System limits

Safety note



WARNING

The system may respond not at all, too late, incorrectly, or without justification due to limits of the system. There is a danger of accident or damage to property. Observe the information on the system limits and intervene actively if necessary. ◀

Functional restrictions

The function may be restricted in the following situations:

- ▷ If the speed of the approaching vehicle is very much higher than that of your own speed.
- ▷ In thick fog, wet conditions or snow.
- ▷ On sharp bends or narrow roads.
- ▷ If the bumper is dirty, iced over or covered, for example by stickers.
- ▷ When a projecting load is being transported.

A Check Control message is displayed in the event of limited functionality.

Manual speed limiter

Principle

The system enables speeds from a value of 30 km/h/20 mph and above to be set as a speed limit. Below the set speed limit, the vehicle can be driven without restriction.

Exceeding the speed limit

In particular situations the speed limit can be deliberately exceeded by accelerating strongly.

The system gives a warning if the travelling speed exceeds the set speed limit.



No brake intervention

If the set speed limit has been reached or unintentionally exceeded, for example when driving downhill, there is no active brake intervention.

If you set a speed limit during the journey which is below the current speed, the vehicle rolls until the driving speed drops below the speed limit.

Overview

Buttons on the steering wheel

Button	Function
	Switches system on/off, see page 144
	Rocker switch: Change speed limit, see page 145

Operation

Switching on

 Press the button on the steering wheel.

The current speed is adopted as the speed limit.

When switching on when at a standstill or driving at low speed, 30 km/h/20 mph is set as the speed limit.

The status display is shown and, depending on the instrument cluster, a marking in the speedometer is set to the corresponding speed.

When activating the speed limit it is possible that Dynamic Stability Control, DSC is activated.

Switching off

 Press the button on the steering wheel.

The system switches off automatically in the following situations, for example:

- ▷ When engaging reverse gear.
- ▷ When switching the engine off.
- ▷ When switching on Cruise Control.

The displays turn off.

Change speed limit

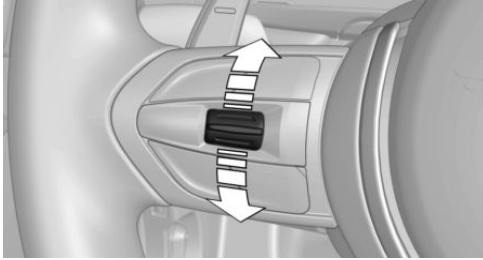

Press the rocker switch repeatedly upwards or downwards until the desired speed limit is set.

- ▶ Every time the rocker switch is pressed to the resistance point, the speed limit is increased or decreased by 1 km/h, 1 mph.
- ▶ Each time the rocker switch is pressed beyond the resistance point, the speed limit is increased or decreased to the next multiple of 10 km/h on the speedometer display.

If you set a speed limit while driving which is below the current speed, the vehicle coasts down to the set speed limit.

Exceeding the speed limit

You can intentionally exceed the speed limit. There is no acoustic warning in such a case.

To exceed the set speed limit intentionally, fully depress the accelerator pedal.

The limit automatically becomes active again as soon as the current speed falls below the set speed limit.

Warning when the speed limit is exceeded

Visual warning

LIM The indicator lamp in the instrument cluster flashes if the set speed limit is exceeded for as long as you exceed the set speed limit.

Acoustic warning

- ▶ If you unintentionally exceed the set speed limit, you will hear an acoustic warning after approximately 5 seconds.
- ▶ If the speed limit is reduced to below the driven speed during the journey, the warning sounds after approximately 30 seconds.
- ▶ If you intentionally exceed the speed limit by fully pressing the accelerator pedal, no warning is given.

Displays in the instrument cluster

Marking of the speed limit

Display in the speedometer:



- ▶ Marker illuminates green: the system is active.
- ▶ Marker does not illuminate: the system is inactive.

Indicator lamp

- LIM**
- ▶ If the indicator lamp is illuminated: the system is switched on.
 - ▶ If the indicator lamp is flashing: set speed limit is exceeded.

Status display

LIMIT 90 Display of the set speed limit.

Dynamic brake lights

Principle

The brake lights flash to warn road users behind your vehicle that you are performing an emergency braking manoeuvre. This can reduce the risk of a rear-end collision.

General



- ▷ Normal braking: brake lights illuminate.
- ▷ Heavy braking: brake lights flash.

Shortly before the vehicle comes to a standstill, the hazard warning lights are activated.

To deactivate the hazard warning lights:

- ▷ Accelerate.
- ▷ Press the hazard warning lights button.

Active Protection

General

The Active Protection safety package consists of systems independent of each other:

- ▷ Attentiveness assistant.
- ▷ PreCrash.
- ▷ PostCrash.

Attentiveness assistant

Principle

The system can detect decreasing attentiveness or tiring of the driver on long monotonous journeys, for example on motorways. In this situation, it is recommended that you take a break.

Safety note



WARNING

The system does not release you from your personal responsibility to assess your physical condition. Increasing inattention or fa-

tigue might not be detected, or may not be detected in good time. There is a danger of accidents. Make sure that the driver is rested and alert. Adapt your driving style to the traffic conditions. ◀

Function

The system is switched on every time the engine is started and cannot be switched off.

After commencement of the journey, the system is adapted to the driver so that an decrease in attention or fatigue can be detected.

This process considers the following criteria:

- ▷ Personal driving style, for example, steering.
- ▷ Driving conditions, for example, time of day, duration of drive.

The system is active from approximately 70 km/h, 43 mph and can display a recommendation to take a break.

Recommendation to take a break

If the driver's attention drops or she/he becomes tired, a note is shown on the Control Display with the recommendation to take a break.

A recommendation to take a break will only be displayed once during an uninterrupted journey.

After a break, another break recommendation cannot be displayed until after approximately 45 minutes at the earliest.

System limits

The function may be restricted in situations such as the following and an incorrect warning, or no warning at all, may be output:

- ▷ If the time is set incorrectly.
- ▷ When the speed is predominantly below approx. 70 km/h, 43 mph.
- ▷ If a sporty driving style is adopted, for example sharp acceleration or fast cornering.

- ▶ In active driving situations, for example frequent lane changes.
- ▶ In poor road conditions.
- ▶ In strong crosswinds.

The system is reset approximately 45 minutes after the vehicle is stopped, for example when taking a break during a long motorway journey.

PreCrash

Principle

The system can detect critical driving situations from 30 km/h/20 mph onwards, which could cause an accident. In these situations, automatically preventative, protective measures are taken to minimise the risk of accident.

Critical driving situations are, for example:

- ▶ Full braking.
- ▶ Severe understeering.
- ▶ Severe oversteering.

When collision warning or front-end collision warning with light braking function is fitted, within the limits of the system, threatened collisions into vehicles in front or stationary vehicles are detected.

Safety note



WARNING

The system does not release you from your personal responsibility. Critical situations cannot be detected reliably or in good time due to limitations of the system. There is a danger of accidents. Adapt your driving style to the traffic conditions. Observe the traffic situation and intervene actively if the situation warrants it. ◀

Function

After the seat belt is fastened, the front seat belts are automatically tightened once when driving away.

When driving in critical situations, the following individual functions become active as required:

- ▶ The front seat belts are automatically pretensioned.
- ▶ The windows are automatically closed.
- ▶ The Glass Roof automatically closes.

If the critical driving situation passes without an accident occurring, the front seat belts are released again. All other systems can be restored to the desired setting.

If the belt tension does not loosen automatically, stop the vehicle and unfasten the seat belt using the red button on the buckle. Fasten the seat belt again before continuing your journey.

PostCrash

Principle

The system can automatically bring the vehicle to a standstill in certain accident situations without the involvement of the driver. The risk of a further collision and its consequences can thereby be reduced.

Harder vehicle braking

In certain situations, it may be necessary to bring the vehicle to a standstill more quickly.

To do this, for a short time the braking pressure applied when stepping on the brake pedal must be higher than the braking pressure achieved by the automatic braking function. The automatic braking process is interrupted as a result.

Cancelling automatic braking

In certain situations, it may be necessary to cancel the automatic braking, such as for an evasive manoeuvre.

Cancel automatic braking:

- ▶ By depressing the brake pedal.
- ▶ By depressing the accelerator pedal.

At a standstill

After the vehicle has come to a halt, the brake is released automatically.

Driving Stability Control Systems

Vehicle equipment

This chapter describes all standard, national and special equipment available for the model series. Therefore equipment which is not installed in your vehicle, for example on account of the selected optional equipment or the country specification, may also be described here. This also applies to safety-relevant functions and systems. Comply with the relevant laws and regulations when using the corresponding functions and systems.

Anti-lock Brake System, ABS

ABS prevents the wheels from locking when the brakes are applied.

Steering control is retained even in the event of full braking, thereby enhancing active road safety.

ABS is ready to operate each time the engine is started.

Brake assist

When the brake is pressed quickly, this system automatically applies maximum braking power assistance. With full braking, this keeps the braking distance as short as possible. It also makes full use of the advantages offered by the Anti-lock Brake System ABS.

The pressure on the brake should be maintained for the duration of the full-braking process.

M Drive

Principle

Individual settings can be made in two preset configurations for the vehicle.

When starting the engine, as standard an efficient vehicle status is active. M Drive is deactivated.







General

Configurations

The configurations are set as follows:

- ▷ "M Drive 1": relaxed, comfortable driving.
- ▷ "M Drive 2": sportive, dynamic driving.

Setting options

Symbol	Meaning
 "DSC"	Dynamic Stability Control DSC, see page 150, and M Dynamic Mode MDM.
 "Engine"	Programs of the M Engine Dynamics Control, see page 100.
 "Chassis"	Programme of the Adaptive M suspension, see page 153.
 "Steering"	Programs of the Servotronic, see page 154.
 "Transmission"	Drivelogic, see page 98: switching modes and Drivelogic drive programs.
 "Head-up displ."	Views of the Head-Up Displays, see page 116.

Configuring M Drive

The preset configurations can be individually set.

On the Control Display:

1. "My Vehicle"
2. "M Drive 1" or "M Drive 2"
3. Selected desired adjustment option.
4. Select the desired channel.



The individual settings are saved for the currently used profile.

With M Drive activated a change is made immediately on the Control Display setting.

Activating/deactivating M Drive

Activating

Press the relevant button on the steering wheel.



- ▷  Activate M Drive 1.
- ▷  Activate M Drive 2.

If in M Drive, DSC OFF or MDM is set, a message appears in the instrument cluster. This message is operated by pressing the button again.

Deactivating

Press the relevant button on the steering wheel again.

Indicator lamps

- ▷  Indicator lamp illuminates: corresponding M Drive is activated.
 - ▷  Indicator lamp flashes: M Drive could not be activated. Anti-blocking system ABS or Dynamic Stability Control DSC control drive stability directly.
- Reactivate M Drive if the indicator stops flashing.

M Drive setting using buttons

With activated M Drive individual settings outside of the M Drive can also be changed, for example, using buttons in the centre console. That deactivates the M Drive.

To reactivate all the settings made on the Control Display for M Drive, briefly press one of the following buttons:

- ▷ 
- ▷ 

To accept the change settings in M Drive, press the corresponding button for a long time.

Reset M Drive

Individual settings can be reset to default values.

1. "My Vehicle"
2. "M Drive 1" or "M Drive 2"
3. "Reset M1" or "Reset M2"
4. "OK"

To interrupt resetting: "Cancel"

Dynamic Stability Control DSC

Principle

The system reduces engine output and applies the brakes on individual wheels, helping, within the limits imposed by the laws of physics, to keep the vehicle safely on course.

General

DSC detects the following unstable driving conditions, for example:

- ▷ Loss of traction at the rear which can lead to oversteer.
- ▷ Loss of grip of the front wheels which can lead to understeer.

Safety notes



WARNING

The system does not release you from your personal responsibility to assess the traffic situation correctly. Due to system limitations, it cannot respond independently in an appropriate manner in all traffic conditions. There is a danger of accidents. Adapt your driving style to the traffic conditions. Observe the traffic situation and intervene actively if the situation warrants it. ◀



WARNING

When driving with a roof load, for example with a roof rack, the higher centre of gravity can mean that driving safety is no longer guaranteed in critical driving situations. There is a danger of accident or damage to property. Do not deactivate Dynamic Stability Control DSC when driving with a roof load. ◀

Overview

Button in the vehicle



DSC OFF button

Indicator and warning lamps



If the indicator lamp is flashing: DSC is regulating the acceleration and braking forces.

If the indicator lamp is illuminated: DSC has failed.

Deactivating DSC: DSC OFF

General

Driving stability during acceleration and cornering is restricted if DSC is deactivated.

To assist driving stability, re-activate DSC as soon as possible.

Deactivating DSC



Press and hold the button – but for no longer than approximately 10 seconds – until the DSC OFF indicator lamp in the instrument cluster is illuminated and DSC OFF is displayed.

DSC is switched off.

Activating DSC



Press the button.

DSC OFF and the DSC OFF indicator lamps are extinguished.

Indicator and warning lamps

DSC OFF is displayed in the instrument cluster when DSC is deactivated.



If the indicator lamp is illuminated: DSC is deactivated.

M Dynamic Mode

Principle

M Dynamic Mode allows driving with higher longitudinal and transverse acceleration on dry carriageways, but with restricted drive stability.

Only in the absolute limit of the range does the system engage for stability purposes by reducing the engine power and by brakes applied to the wheels. In this driving situation, additional steering corrections may be required.

Safety note



WARNING

With activated M Dynamic Mode stabilising engagements are only carried out to a reduced degree. There is a danger of accident or damage to property. Adapt to the traffic conditions. Observe the traffic situation and intervene actively if the situation warrants it. In the event of a warning, do not move the steering wheel with unnecessary force. ◀

To assist driving stability, re-activate DSC as soon as possible.

Activating MDM



Press the button briefly.

In the instrument cluster, the indicator lamps MDM and DSC OFF illuminate.

Deactivating MDM



Press the button.

Indicator lamps MDM and DSC OFF no longer illuminate.

Via M Drive

On the Control Display:

1. "My Vehicle"
2. "M Drive 1" or "M Drive 2"
3. "DSC"
4. "MDM"

To call up the desired M Drive with the selected settings, press the corresponding button on the steering wheel:







A message appears in the instrument cluster. This message is operated by pressing the button again.

Deactivating MDM

Press the corresponding button 1 or button 2 on the steering wheel again.

M Dynamic Mode and the settings selected under M Drive are deactivated.

Indicator and warning lamps

Symbol	Description
	Indicator lamps illuminate: M Dynamic Mode is activated.
	
	DSC indicator lamp also flashes: M Dynamic Mode is regulating the driving and braking forces.
	Indicator lamps illuminate: M Dynamic Mode or DSC has failed.
	

Active M Differential

Principle

The active M Differential blocks the rear axis transmission steplessly, depending on the drive situation. In so doing, even with the DSC switched off and in M Dynamic Mode, spinning of a single rear wheel is avoided and therefore optimum traction is provided under all driving conditions.

The driver is responsible for a driving style appropriate to the situation.

Adaptive M suspension

Principle

The system reduces unwanted vehicle movements when a dynamic driving style is used or when driving on uneven roads.

Depending on the road condition and the driving style, this enhances driving dynamics and driving comfort.

Programs

Possibilities for adjusting the tuning of the shock absorbers:

- ▶ "Comfort": comfort-oriented.
- ▶ "Sport": balanced.
- ▶ "Sport Plus": consistently sporty.

Selecting a channel

Via M Drive

On the Control Display:

1. "My Vehicle"
2. "M Drive 1" or "M Drive 2"
3. "Chassis"
4. Select the desired channel.

Setting is immediately accepted with active M Drive.

To activate the desired M Drive with the selected settings, press the corresponding button on the steering wheel:

- ▶ 
- ▶ 

Using the button



- ▶  Press button until the desired programme is displayed in the instrument cluster.

Display in the instrument cluster

- ▶  Adaptive M suspension with selected programme and activated display of driving dynamics system states, see page 108.

Drive-off assistant

Principle

The system provides support when driving off on upward gradients. It is not necessary to use the parking brake for this.

Driving off with drive-off assistant

1. Hold the vehicle in place by depressing the foot brake.
2. Release the foot brake and drive off without delay.

The vehicle is held for approximately 2 seconds after the foot brake has been released. Depending on the vehicle's load, the vehicle may roll backwards a little.

Servotronic

Principle

Servotronic is a speed-dependent power steering system.

The system provides more steering force assistance at lower speeds than at higher speeds. This makes it easier to park, for example, and provides a more direct steering feel when driving at higher speeds.

In addition, the steering force is adapted according to the drive programme, so that a direct, sporty feel or a comfortable steering response is conveyed.

Programs

Adjustment possibilities of the steering force:

- ▷ "Sport Plus": high.
- ▷ "Sport": medium.
- ▷ "Comfort": low.

Selecting a channel

Via M Drive

On the Control Display:

1. "My Vehicle"
2. "M Drive 1" or "M Drive 2"
3. "Steering"
4. Select the desired channel.

Setting is immediately accepted with active M Drive.

To activate the desired M Drive with the selected settings, press the corresponding button on the steering wheel:

- ▷ 
- ▷ 

Using the button



 Press button until the desired programme is displayed in the instrument cluster.

Display in the instrument cluster

 Servotronic with selected programme with activated display of the system states of the driving dynamics, see page 108.

Driving comfort

Vehicle equipment

This chapter describes all standard, national and special equipment available for the model series. Therefore equipment which is not installed in your vehicle, for example on account of the selected optional equipment or the country specification, may also be described here. This also applies to safety-relevant functions and systems. Comply with the relevant laws and regulations when using the corresponding functions and systems.

Cruise Control

Principle

This system allows a desired speed to be set using the buttons on the steering wheel. The desired speed is then maintained by the system. To do this, the system automatically accelerates and brakes as necessary.

General

Characteristics of Cruise Control may change in certain areas depending on vehicle setting.

Safety notes

 **WARNING**
The system does not release you from your personal responsibility to assess the traffic situation correctly. Due to system limitations, it cannot respond independently in an appropriate manner in all traffic conditions. There is a danger of accidents. Adapt your driving style to the traffic conditions. Observe the traffic situation and intervene actively if the situation warrants it. ◀



WARNING

Using the system in the following situations may increase the risk of an accident, for example:

- ▶ On stretches of road with many corners and bends.
- ▶ In heavy traffic.
- ▶ If the road is icy, if there is fog or snow, if conditions are wet or on a loose road surface.

There is a danger of accident or damage to property. Only use the system if it is possible to drive at a constant speed. ◀





WARNING

The desired speed can be inadvertently set or called up incorrectly. There is a danger of accidents. Adapt the desired speed to the traffic conditions. Observe the traffic situation and intervene actively if the situation warrants it. ◀

Overview

Buttons on the steering wheel

Button	Function
	Cruise Control on/off, interrupt, see page 156.
	Calls up speed, resumes Cruise Control, see page 157.
	Rocker switch: sets the speed, see page 156.

Switching the Cruise Control on/off and interrupting

Switching on

 Press the button on the steering wheel.

The speedometer marker is set to the current speed.

Cruise Control can be used.

Dynamic Stability Control DSC is switched on, if necessary.

Switching off

 Press the button on the steering wheel.

- ▷ When activated: press twice.
- ▷ When interrupted: press once.

The displays turn off. The saved desired speed is deleted.

Interrupting manually

 When the system is activated, press the button on the steering wheel.

Interrupting automatically

The system interrupts automatically in the following situations:

- ▷ If the driver brakes.
- ▷ If the clutch is pressed for a few seconds or released with no gear engaged.
- ▷ If too high a gear has been engaged for the speed.
- ▷ When M Dynamic Mode MDM is activated or Dynamic Stability Control DSC is deactivated.
- ▷ If Dynamic Stability Control DSC intervenes.

Setting the speed

Holding or setting the speed

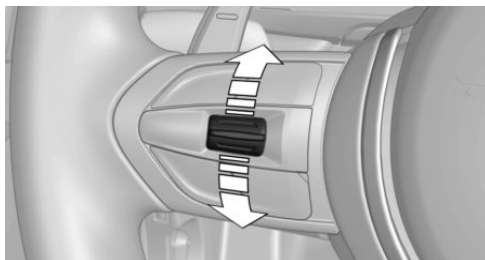

While the system is interrupted, press the rocker switch.

If the system is switched on, the current speed is maintained and saved as the desired speed.

The saved speed is displayed in the speedometer and in the instrument cluster, see page 157.

Dynamic Stability Control DSC is switched on, if necessary.

Changing speed

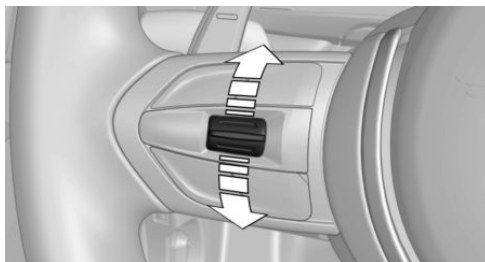

Press the rocker switch repeatedly upwards or downwards until the desired speed is set.

If the system is active, the displayed speed is stored and the vehicle reaches the stored speed when the road is clear.

- ▷ Each time the rocker switch is pressed to the resistance point, the desired speed is increased or decreased by approximately 1 km/h, 1 mph.

- ▶ Each time the rocker switch is pressed beyond the resistance point, the desired speed is increased or decreased to the next multiple of 10 km/h on the speedometer display.

The maximum speed which can be set depends on the vehicle.

- ▶ Pressing the rocker switch to the resistance point and holding up there accelerates or decelerates the vehicle without pressing the accelerator pedal.

The speed is maintained after releasing the rocker switch. Pressing beyond the resistance point accelerates the vehicle more rapidly.

Resuming Cruise Control

General

If Cruise Control is interrupted, it can be resumed by calling up the saved speed.

Before calling up the saved speed, make sure that the difference between the current speed and the saved speed is not excessively large. Otherwise, there may be inadvertent braking or acceleration.

The saved speed value is deleted and can no longer be called up in the following instances:

- ▶ When the system is switched off.
- ▶ When the ignition is switched off.

Resuming a saved speed

 Press the button on the steering wheel.

The saved speed is resumed and maintained.

Displays in the instrument cluster

Indicator lamp

 Depending on the equipment the indicator lamp in the instrument cluster

shows whether the system is switched on.

Desired speed and saved speed



- ▶ Green mark illuminated: system is active, the mark shows the desired speed.
- ▶ Orange/white mark illuminated: system is interrupted, the mark shows the saved speed.
- ▶ Marker does not illuminate: the system is inactive.

Status display



Selected desired speed.

If no speed is displayed, the conditions required for operation may not be fulfilled at the present time.

Displays in the Head-Up Display

Some information from the system can also be shown in the Head-Up Display.

System limits

Engine power

The desired speed will also be maintained on downward gradients, but may not be reached on upward gradients if engine power is insufficient.

Park Distance Control PDC

Principle

PDC provides assistance when parking the vehicle. Slowly approaching an object in behind, or with front PDC, in front of, your vehicle is signalled by means of:

- ▶ Acoustic signals.
- ▶ Visual display.

General

The ultrasonic sensors for measuring the distances are located in the bumpers.

The range is approximately 2 m, 6 ft depending on the obstacle and environment.

An acoustic warning is only issued in the following situations:

- ▷ At the front sensors and at the two corner sensors at the rear at a distance of approximately 60 cm, 24 in from the object.
- ▷ At the middle sensors at the rear at a distance of approx. 1.50 m, 5 ft from the object.
- ▷ If there is a collision risk.

Safety notes

WARNING

The system does not release you from your personal responsibility to assess the traffic situation correctly. Due to system limitations, it cannot respond independently in an appropriate manner in all traffic conditions. There is a danger of accidents. Adapt your driving style to the traffic conditions. Observe the traffic situation and intervene actively if the situation warrants it. ◀

WARNING

If the vehicle is travelling at high speed when Park Distance Control PDC is activated, there may be a delayed warning because of physical conditions. There is a danger of injury or damage to property. Avoid approaching an object at speed. Avoid moving off at speed while Park Distance Control PDC is not yet active. ◀

Overview

With front PDC: button in vehicle



 Park Assistant button

Ultrasonic sensors



Ultrasonic sensors of the PDC, for example in the bumpers.

Operating requirements

To ensure full functional capability:

- ▷ Do not cover sensors, for example by stickers, bicycle rack.
- ▷ Keep the sensors clean and unobstructed.

Switching on/off

Switching on automatically

While the engine is running, engage selector lever position R.

Automatic switching off when moving forwards

The system switches off when a certain distance or speed is exceeded.

Switch the system back on if necessary.

With front PDC: switching on/off manually



Press the Park Assistant button.

- ▷ On: LED is illuminated.
- ▷ Off: LED is extinguished.

Warning

Acoustic signals

An intermittent sound indicates that the vehicle is approaching an object. For instance, if an object is identified to the rear left of the vehicle, the acoustic signal is output from the rear left loudspeaker.

The shorter the distance to an object becomes, the shorter the intervals become.

If the distance to a detected object is less than approximately 25 cm, 10 in, a continuous tone sounds.

With front PDC: if there are simultaneously objects in front of and behind the vehicle, an alternating continuous tone sounds.

Volume control

It is possible to set the ratio between the volume of the PDC acoustic signal and the volume of the entertainment source playback.

Via iDrive:

1. "My Vehicle"
2. "iDrive settings"
3. "Sound"
4. "Volume settings"
5. "PDC"
6. Set the desired value.

The setting is saved for the currently used driver profile.

Visual warning



The approach of the vehicle to an object is shown on the Control Display. Objects that are further away are already displayed before an acoustic signal is given.

A display is superimposed as soon as PDC is activated.

The recording range of the sensors is shown in green, yellow and red.

If the rear-view camera image is displayed, it is possible to change over to PDC:

1. If necessary, tilt the Controller to the left.
2.  "Rear view camera"

System limits

Safety note



WARNING

The system may respond not at all, too late, incorrectly, or without justification due to limits of the system. There is a danger of accident or damage to property. Observe the information on the system limits and intervene actively if necessary. ◀

Limits of the ultrasound measurement

The detection of objects might not be possible if the limits of the physical ultrasound measurement are exceeded, such as for instance in the following situations:

- ▷ If there are small children and animals.

- ▷ If persons are wearing certain types of clothing, for example a coat.
- ▷ If there is external disruption to the ultrasound, for example by passing vehicles or loud machines.
- ▷ If the sensors are dirty, iced-up, damaged or incorrectly adjusted.
- ▷ In certain weather conditions, for example high humidity, wet conditions, snowfall, extreme heat or strong wind.
- ▷ For the trailer drawbars and tow hitches of other vehicles.
- ▷ For thin or wedge-shaped objects.
- ▷ For moving objects.
- ▷ For higher, protruding objects, for example projecting walls or loads.
- ▷ For objects with corners and sharp edges.
- ▷ For objects with fine surfaces or structures, for example fences.
- ▷ For objects with porous surfaces.
- ▷ When a projecting load is being transported.
- ▷ Low objects already indicated, such as kerbs, may enter the sensors' blind areas before or after a continuous tone is given.

False alarms

Under the following conditions, the system can issue a warning although there is no obstacle in the detection range:

- ▷ In heavy rain.
- ▷ If the sensors are very dirty or covered with ice.
- ▷ If the sensors are covered with snow.
- ▷ On rough road surfaces.
- ▷ On uneven ground, for example speed bumps.
- ▷ In large, rectangular buildings with smooth walls, for example underground car parks.
- ▷ In washing bays and car washes.

- ▷ Due to dense exhaust gases.
- ▷ Due to other ultrasonic sources, for example sweeping machines, steam-jet cleaners or neon lights.

As soon as the disruption by other ultrasound sources is no longer present, the system is fully functional again.

Malfunction

A Check Control message is shown.

The recording area of the sensors is shown hatched on the Control Display.

PDC has failed. Have the system checked by a Service Partner of the manufacturer or another qualified Service Partner or a specialist workshop.

Surround View

Principle

Surround view contains various camera assistance systems, providing support when parking, manoeuvring and exits and junctions with poor visibility.

- ▷ Rear-view camera, see page 160.
- ▷ Side View, see page 163.
- ▷ Top view, see page 164.

Rear-view camera

Principle

The rear-view camera provides assistance when reverse parking or manoeuvring. To achieve this, the area behind the vehicle is displayed on the Control Display.

Safety note



WARNING

The system does not release you from your personal responsibility to assess the traffic situation correctly. There is a danger of ac-

idents. Adapt your driving style to the traffic conditions. Additionally, look directly to check the traffic situation and the area around the vehicle and intervene actively in the corresponding situations. ◀

Overview

With the corresponding equipment: button in the vehicle



Park Assistant button

Camera

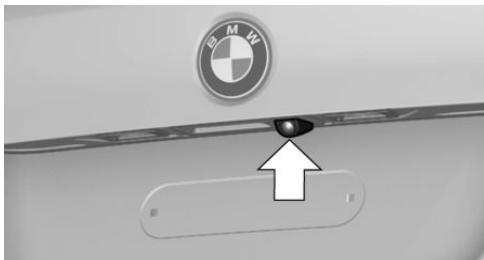

The camera lens is located in the handle strip of the boot lid.

Dirt can impair the quality of the picture. Clean the camera lens if required.

Switching on/off

Switching on automatically

The system is automatically switched on if selector lever position R is engaged while the engine is running.

The image from the rear-view camera is displayed if the system was switched on using the iDrive.

Automatic switching off when moving forwards

The system switches off when a certain distance or speed is exceeded.

Switch the system back on if necessary.

With the corresponding equipment: switching on/off manually



Press the Park Assistant button.

- ▷ On: LED is illuminated.
- ▷ Off: LED is extinguished.

Park Distance Control PDC is shown on the Control Display.

Switching the view via iDrive

With Park Distance Control PDC activated or Top View switched on:

1. If necessary, tilt the Controller to the left.
2.  "Rear view camera"

The image from the rear-view camera is shown.

Display on the Control Display

Operating requirements

- ▷ The rear-view camera is switched on.
- ▷ The boot lid is completely closed.
- ▷ Keep the detection area of the camera clear. A projecting load can lead to malfunctions.

Activating assistance functions

A number of assistance functions can be active simultaneously.

If necessary, tilt the Controller to the left.

- ▷ Parking aid lines

"Parking guidance lines"

Driving path lines and turning circle lines are shown.

▷ Obstacle marking

"Obstacle marking"

With the corresponding equipment, spatially shaped markings are displayed.

Driving path lines

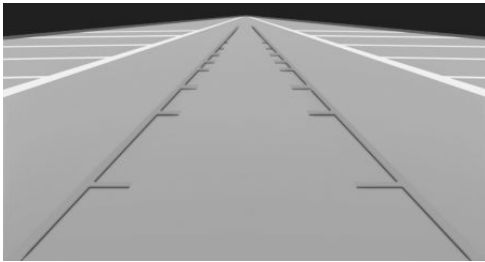

Driving path lines can appear in the image from the rear-view camera.

The driving path lines help to estimate the required space when parking and manoeuvring on a level road surface.

The driving path lines are dependent on the current steering angle and are continuously adapted to steering wheel movements.

Turning circle lines

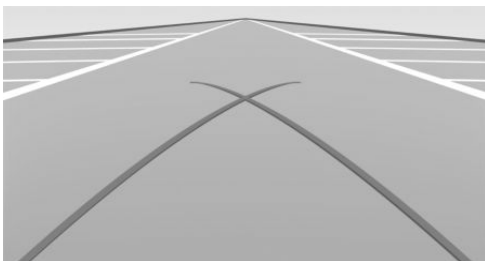

The turning circle lines can only be shown in the image from the rear-view camera together with driving path lines.

The turning circle lines show the course of the smallest possible turning circle on a level road surface.

Once the steering wheel has been turned beyond a certain angle, only one turning circle line is displayed.

Obstacle marking

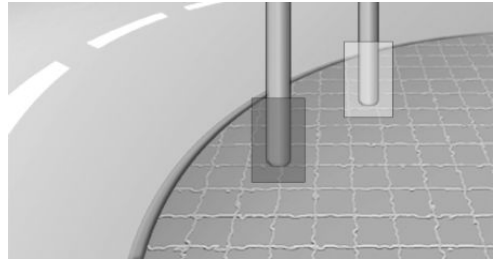

With the corresponding equipment, obstacle markings can be shown in the image from the rear-view camera.

The colour incrementation corresponds to the markings of Park Distance Control PDC.

Parking with the help of driving lane and turning circle lines

1. Position the vehicle so that the turning circle lines are within the limit of the parking space.

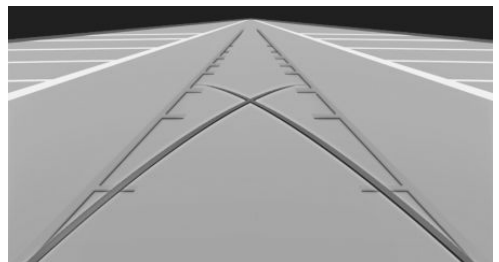

- Turn the steering wheel so that the driving lane line covers the corresponding turning circle line.

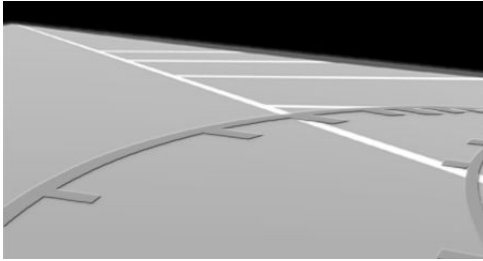

Display settings

Brightness

With rear-view camera switched on:

- If necessary, tilt the Controller to the left.
-  Select the symbol.
- Turn the Controller until the desired setting is reached and press the Controller.

Contrast

With rear-view camera switched on:

- If necessary, tilt the Controller to the left.
-  Select the symbol.
- Turn the Controller until the desired setting is reached and press the Controller.

System limits

Detection of objects

Very low obstacles and higher, protruding objects such as ledges cannot be detected by the system.

With the corresponding equipment, certain assistance functions also take into account data from Park Distance Control PDC.

Observe the notes in the chapter on Park Distance Control PDC.

The objects shown on the Control Display may be closer than they appear. Do not estimate the distance to objects based on the display.

Side View

Principle

Side View provides you with an advance view of crossing traffic at blind exits. Road users hidden by obstacles at the side are only detected very late from the driver's seat. In order to improve the view, two cameras in the front area of the vehicle scan the area to the side. The camera pictures are shown simultaneously on the Control Display.

Safety note



WARNING

The system does not release you from your personal responsibility to assess the traffic situation correctly. There is a danger of accidents. Adapt your driving style to the traffic conditions. Additionally, look directly to check the traffic situation and the area around the vehicle and intervene actively in the corresponding situations. ◀

Overview

Button in the vehicle



Side View

Cameras

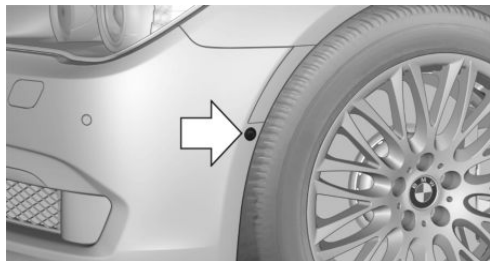

Two cameras integrated into the bumpers provide detection.

Both camera lenses are located at the side of the bumper.

Dirt can impair the quality of the picture. Clean the camera lenses if required.

Switching on/off

Switching on/off manually



Press the button.

Automatic switching off when moving forwards

The system switches off when a certain distance or speed is exceeded.

Switch the system back on if necessary.

Display

The area to the side is shown on the Control Display.

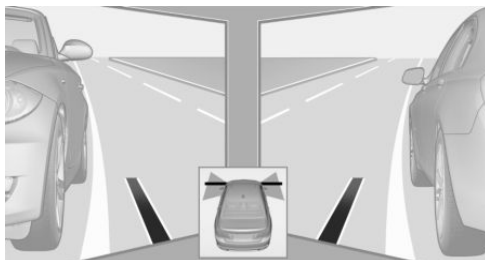

Artificial lines on the lower screen edge show the position of the vehicle front.

Brightness

With Side View switched on:

1. If necessary, tilt the Controller to the left.
2. ☀ "Brightness"
3. Turn the Controller until the desired setting is reached and press the Controller.

Contrast

With Side View switched on:

1. If necessary, tilt the Controller to the left.
2. ● "Contrast"
3. Turn the Controller until the desired setting is reached and press the Controller.

System limits

The pick-up range of the cameras is a maximum of 100 m, 330 ft.

Top View

Principle

Top View assists you with manoeuvring and parking. To achieve this, the area around the door and road is displayed on the Control Display.

General

The two cameras in the exterior mirrors and the rear-view camera are used to view the area around the vehicle.

The range at the sides and rear is at least 2 m, approximately 7 ft.

In this way, obstacles up to the height of the exterior mirror are detected early.

Safety note



WARNING

The system does not release you from your personal responsibility to assess the traffic situation correctly. There is a danger of accidents. Adapt your driving style to the traffic conditions. Additionally, look directly to check the traffic situation and the area around the vehicle and intervene actively in the corresponding situations. ◀

Overview

Button in the vehicle



Park Assistant button

Cameras

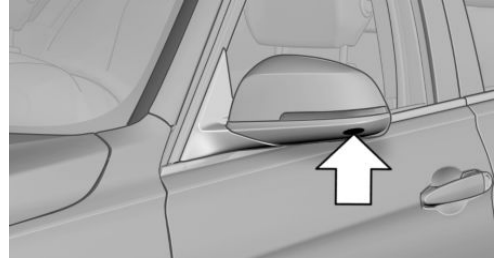

Cameras in the bottom of the mirror housings.

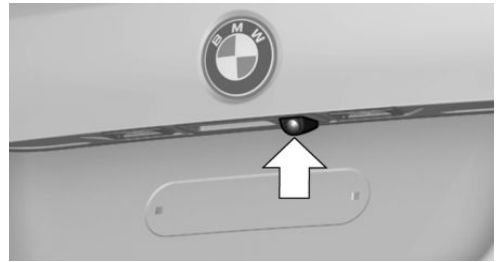

Rear-view camera

Dirt can impair the quality of the picture. Clean the camera lenses if required.

Switching on/off

Switching on automatically

The system is automatically switched on if selector lever position R is engaged while the engine is running.

The images from Top View and PDC are displayed if the system was switched on using the iDrive.

Automatic switching off when moving forwards

The system switches off when a certain distance or speed is exceeded.

Switch the system back on if necessary.

Switching on/off manually



Press the Park Assistant button.

- ▷ On: LED is illuminated.
- ▷ Off: LED is extinguished.

Top View is shown.

Display

Visual warning

When the vehicle is approaching an object it will be shown on the Control Display.

If there is a short distance to an object at the front, a red bar in front of the vehicle is displayed in the same way as for the PDC display.

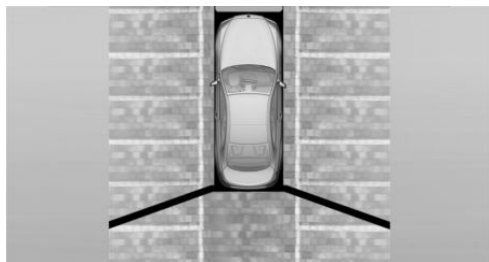

The display appears as soon as Top View is activated.

If the rear-view camera image is displayed, it is possible to change over to Top View:

1. If necessary, tilt the Controller to the left.
2. "Rear view camera"

Brightness

With Top View switched on:

1. If necessary, tilt the Controller to the left.
2. Select the symbol.
3. Turn the Controller until the desired setting is reached and press the Controller.

Contrast

With Top View switched on:

1. If necessary, tilt the Controller to the left.
2. Select the symbol.
3. Turn the Controller until the desired setting is reached and press the Controller.

Displaying the turning circle and driving lane line

- ▷ The static red turning circle line indicates the space requirement to the side with full steering angle.
- ▷ The variable green driving lane line helps to estimate the actual space requirement to the side.

The lane line depends on the engaged gear and the current steering angle. The lane line is continuously adjusted by the steering wheel movement.

1. If necessary, tilt the Controller to the left.
2. "Parking guidance lines"

The turning circle and driving path lines are displayed.

System limits

Top View cannot be used in the following situations:

- ▷ With a door open.
- ▷ With the boot lid open.
- ▷ With an exterior mirror folded in.
- ▷ In poor light conditions.

In some of these situations a Check Control message is displayed.

Park Assistant

Principle

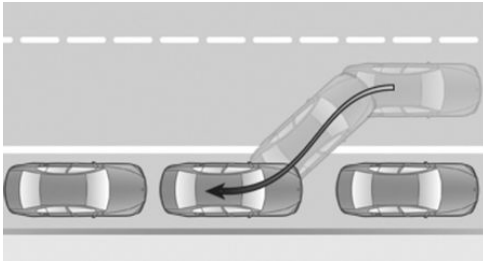

The system supports you when parking parallel to the road.

General

Operation of the Park Assistant is divided into three steps:

- ▷ Switching on and activating.
- ▷ Parking space search.
- ▷ Parking.

Ultrasonic sensors measure parking spaces on both sides of the vehicle.

The Park Assistant calculates the ideal parking line and takes over steering during the process of parking.

The status of the system and the actions required are shown on the Control Display.

The Park Assistant uses the sensors of the Park Distance Control, PDC.

Safety notes



WARNING

The system does not release you from your personal responsibility to assess the traffic situation correctly. Due to system limitations, it cannot respond independently in an appropriate manner in all traffic conditions. There is a danger of accidents. Adapt your driving style to the traffic conditions. Observe the traffic situation and intervene actively if the situation warrants it. ◀



NOTE

The Park Assistant may steer across kerb or up onto kerbs. There is a danger of damage to property. Observe the traffic situation and intervene actively if the situation warrants it. ◀

In addition, the safety notes for the Park Distance Control, PDC apply.

Overview

Button in the vehicle



Park Assistant button

Ultrasonic sensors

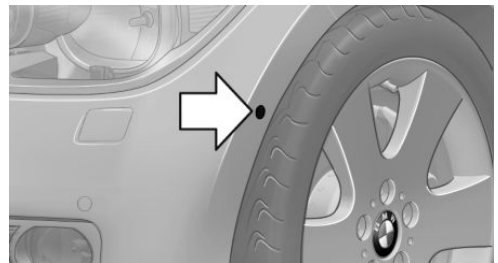

The four ultrasonic sensors to measure parking spaces are located on side of vehicle at front and rear.

Operating requirements

Ultrasonic sensors

To ensure full functional capability:

- ▷ Do not cover the sensors, for example with stickers.
- ▷ Keep the sensors clean and unobstructed.

For measuring parking spaces

- ▷ The vehicle must be driving forwards in a straight line at speeds up to approximately 35 km/h, approximately 22 mph.
- ▷ Maximum distance to the row of parked vehicles: 1.5 m, approximately 5 ft.

Suitable parking space

- ▷ Gap between two objects, each at least 1.5 m, approximately 5 ft long.
- ▷ Minimum length of gap between two objects: own vehicle length plus approximately 1.2 m, approximately 4 ft.
- ▷ Minimum depth: approximately 1.5 m, approximately 5 ft.

For parking

- ▷ Doors and boot lid are closed.
- ▷ Parking brake is released.
- ▷ You must indicate accordingly when parking into parking spaces on the driver's side.

Switching on and activating

Switching on with the button

- ▷  Press the Park Assistant button. The LED is illuminated.

The current status of the parking space search is displayed on the Control Display.

- ▷  Park Assistant is automatically activated.

Switching on with reverse gear



Engage reverse gear.

The current status of the parking space search is displayed on the Control Display.

- To activate:  "Park Assist"

Display on the Control Display

System is activated/deactivated

Symbol	Meaning
	Grey: system not available. White: system available but not activated.
	System is activated.

Parking space search and status of the system

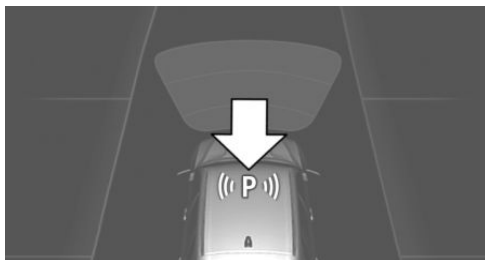

- ▷ Symbol P on the vehicle diagram: Park Assistant is activated and the parking space search is active.
- ▷ Suitable parking spaces are shown on the Control Display on the edge of the roadway next to the vehicle symbol. With active Park Assistant, the suitable parking spaces are highlighted in colour.
- ▷  Parking process active. Steering has been taken over.
- ▷ The parking space search is active whenever the vehicle is driving forwards at low speed, even with deactivated system. If the system is deactivated, the displays on the Control Display are shown grey.

Parking with the Park Assistant

Driving into a parking space

1.  Press the Park Assistant button or engage reverse gear to switch on the Park Assistant, see page 168. Activate Park Assistant if necessary.

 Park Assistant is activated.

2. Drive past the line of parked vehicles at a speed up to approximately 35 km/h, approximately 22 mph and at a distance of maximum 1.5 m, approximately 5 ft.

The status of the parking space search and possible parking spaces are shown on the Control Display, see page 168.

3. Follow the instructions on the Control Display.



To achieve an optimum parking position, wait for the automatic steering process after changing gear at standstill.

The end of the parking process is displayed on the Control Display.

4. Straighten up the parking position, if applicable.

Cancelling manually

You can cancel the Park Assistant at any time:

- ▶  Press the Park Assistant button.
- ▶  "Park Assist" Select the symbol on the Control Display.

Cancelling automatically

The system automatically cancels in the following situations:

- ▶ If the driver grasps the steering wheel or steers the vehicle.
- ▶ When selecting gear, which does not correspond to the information on the Control Display.

- ▶ At speeds over approximately 10 km/h, approximately 6 mph.
- ▶ On snow-covered or slippery road surfaces, if necessary.
- ▶ Any obstacles difficult to get over, for example kerbs.
- ▶ With obstacles that suddenly arise.
- ▶ If the Park Distance Control PDC shows gaps that are too small.
- ▶ When a maximum number of parking attempts or parking time is exceeded.
- ▶ If turn indicator is set opposite to desired parking side.
- ▶ When changing to other functions on the Control Display.

A Check Control message is shown.

Flashing display on selector lever of double clutch transmission

In some situations, the actually engaged gearbox setting may be different from the selector lever position after a cancellation of function, and the display in the selector lever flashes.

In these cases, refer to the display in the instrument cluster, see page 98.

Resuming

You can continue a cancelled parking process, if applicable.

To do this, reactivate the Park Assistant, see page 168, and follow the instructions on the Control Display.

Switching off

The system can be switched off as follows:

- ▶  Press the Park Assistant button.
- ▶ Switch the ignition off.

System limits

Safety note



WARNING

The system may respond not at all, too late, incorrectly, or without justification due to limits of the system. There is a danger of accident or damage to property. Observe the information on the system limits and intervene actively if necessary. ◀

No parking assistance

The Park Assistant does not provide assistance in the following situations:

- ▷ On sharp bends.

Functional restrictions

The function may be restricted in the following situations, for example:

- ▷ On uneven road surfaces, for example gravel roads.
- ▷ On slippery ground.
- ▷ On steep upward or downward gradients.
- ▷ If leaves have collected or snow has drifted or been piled up in the parking space.
- ▷ If there are ditches or sudden drops, for example a quayside.

Limits of the ultrasound measurement

The detection of objects might not be possible if the limits of the physical ultrasound measurement are exceeded, such as for instance in the following situations:

- ▷ If there are small children and animals.
- ▷ If persons are wearing certain types of clothing, for example a coat.
- ▷ If there is external disruption to the ultrasound, for example by passing vehicles or loud machines.
- ▷ If the sensors are dirty, iced-up, damaged or incorrectly adjusted.

- ▷ In certain weather conditions, for example high humidity, wet conditions, snowfall, extreme heat or strong wind.
- ▷ For the trailer drawbars and tow hitches of other vehicles.
- ▷ For thin or wedge-shaped objects.
- ▷ For moving objects.
- ▷ For higher, protruding objects, for example projecting walls or loads.
- ▷ For objects with corners and sharp edges.
- ▷ For objects with fine surfaces or structures, for example fences.
- ▷ For objects with porous surfaces.
- ▷ When a projecting load is being transported.
- ▷ Low objects already indicated, such as kerbs, may enter the sensors' blind areas before or after a continuous tone is given.

In some cases, parking spaces may be detected that are not suitable or suitable parking spaces may not be detected.

Malfunction

A Check Control message is shown.

The Park Assistant has failed. Have the system checked by a Service Partner of the manufacturer or another qualified Service Partner or a specialist workshop.

Air conditioning

Vehicle equipment

This chapter describes all standard, national and special equipment available for the model series. Therefore equipment which is not installed in your vehicle, for example on account of the selected optional equipment or the country specification, may also be described here. This also applies to safety-relevant functions and systems. Comply with the relevant laws and regulations when using the corresponding functions and systems.

Interior air quality

An emissions-tested interior and the installation of microfilters and a climate-control system with functions for controlling the temperature, air flow and air recirculation have improved air quality inside the vehicle.

In addition there are other functions which depend on the vehicle's equipment, for example microfilter/activated charcoal filter, automatic air conditioning with automatic air recirculation control AUC, and independent ventilation.

Automatic air conditioning

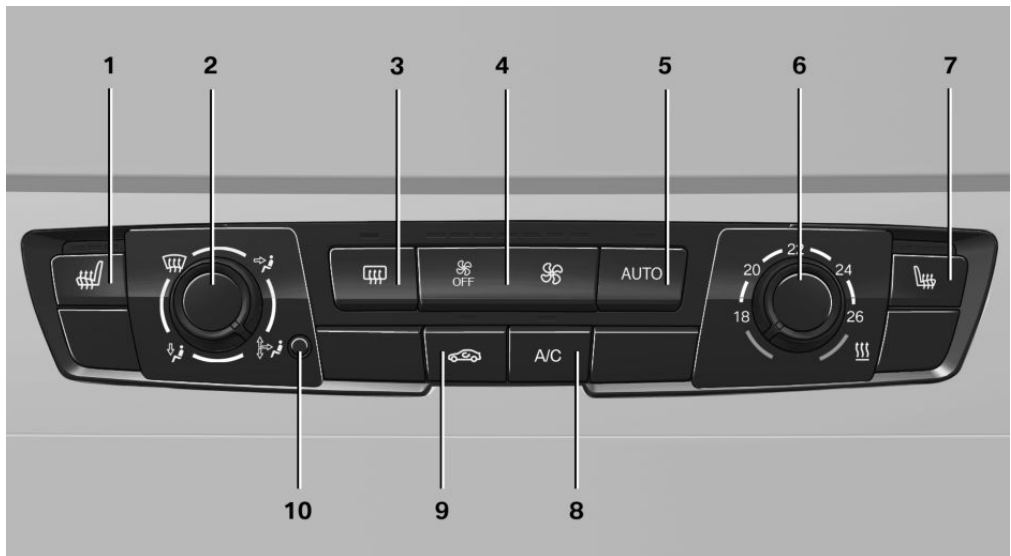

- | | | | |
|---|---------------------------------------|----|--|
| 1 | Seat heating, left 69 | 6 | Temperature |
| 2 | Air distribution | 7 | Seat heating, right 69 |
| 3 | Rear window heating | 8 | Cooling function |
| 4 | Air flow | 9 | Recirculated-air mode |
| 5 | AUTO program | 10 | Interior-temperature sensor |

Air conditioning functions in detail

Switches system on/off

Switching on

Press any button, with the following exceptions:

- ▷ Rear window heating.
- ▷ Seat heating.

Switching off



In the lowest setting, press the left of the button.

Temperature

Principle

The automatic air conditioning adjusts to the set temperature as quickly as possible, using maximum cooling or heating power if necessary. The temperature is then maintained.

Adjusting



Turn the wheel to select the desired temperature.

Avoid switching between different temperature settings in rapid succession. The automatic air conditioning will otherwise not have sufficient time to establish the temperature selected.

Cooling function

Principle

Interior air is cooled and dried, then reheated to suit the temperature setting.

The interior can only be cooled when the engine is running.

Switching on/off



Press the button.

The cooling function is switched on or off.

Depending on weather conditions, the windscreen and side windows may mist over for a short time when the engine is started.

The cooling function is switched on automatically in the AUTO program.

When the automatic air conditioning is in operation, condensation, see page 195, develops which exits underneath the vehicle.

AUTO program

Principle

The air flow, air distribution and temperature are automatically regulated.

Switching on/off



Press the button.

Depending on the selected temperature and external influences, the air is directed towards the windscreen, side windows, and upper body, and into the footwell.

The cooling function, see page 172, is switched on automatically in the AUTO program.

Recirculated-air mode

Principle

If the air outside the vehicle has an unpleasant odour or contains pollutants, the supply to the interior of the vehicle can be shut off. The air inside the vehicle is then recirculated.

Operation



Press the button repeatedly to call up an operating mode:

- ▷ LED off: ambient air is constantly entering the car.
- ▷ LED on, recirculated-air mode: the ambient air supply is permanently shut off.

The recirculated-air mode automatically switches off after a given time depending on the ambient conditions, to avoid condensation.

Continuous recirculated-air mode deteriorates the air quality in the interior and condensation on the windows increases.

In the event of condensation, switch off the recirculated-air mode and increase the air flow if necessary.

Adjusting the air flow manually

Principle

The air flow for air conditioning can be set manually.

Operation



Press left or right side of button: reduce or increase air flow.

The air flow of the air conditioning system is reduced as necessary to save the battery.

Adjusting the air distribution manually

Principle

The air distribution for air conditioning can be set manually.

Operation



Turn the wheel to select the desired programme or the desired intermediate setting.

- ▷ Windows.
- ▷ Upper body area.
- ▷ Windows, upper body area and footwell.
- ▷ Footwell.

Defrosting windows and removing condensation

Perform the following settings to defrost the windows and remove condensation:

- ▷ Direct the air distribution onto the windows.
- ▷ Increase the air flow.
- ▷ Increase the temperature.
- ▷ Switch on the cooling function if needed.

Rear window heating



Press the button. The LED is illuminated.

The rear window heating is switched off automatically after a certain period of time.

Microfilter

In outside and recirculated-air mode, the microfilter filters dust and pollen from the air.

Have this filter replaced during maintenance, see page 229, of the vehicle.

Automatic air conditioning with extended functionality

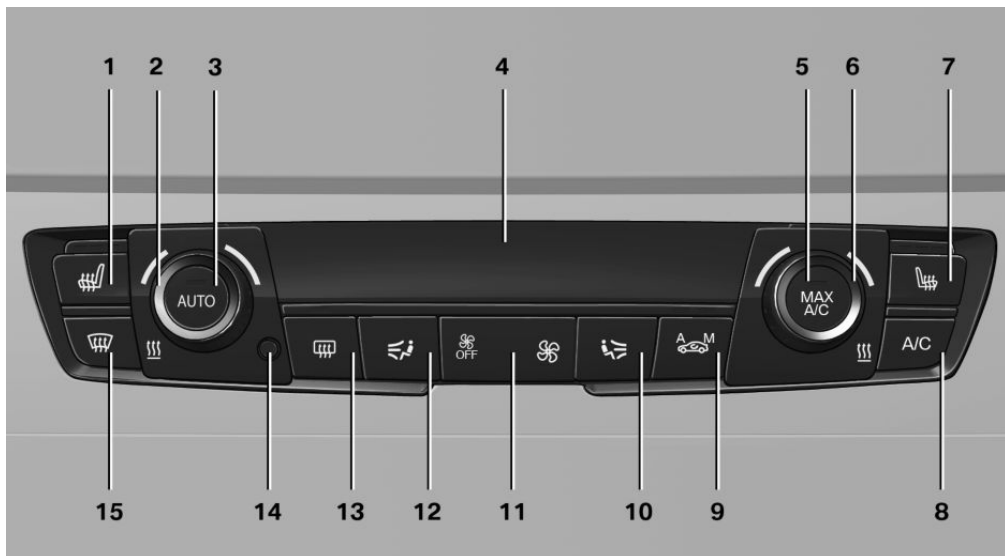

- | | |
|--|---|
| <p>1 Seat heating, left 69</p> <p>2 Temperature, left</p> <p>3 AUTO program</p> <p>4 Display</p> <p>5 Maximum cooling effect</p> <p>6 Temperature, right</p> <p>7 Seat heating, right 69</p> <p>8 Cooling function</p> | <p>9 AUC/recirculated-air mode</p> <p>10 Air distribution, right</p> <p>11 Air flow, AUTO intensity</p> <p>12 Air distribution, left</p> <p>13 Rear window heating</p> <p>14 Interior temperature sensor — never cover</p> <p>15 Defrosting windows and removing condensation</p> |
|--|---|

Air conditioning functions in detail

Switches system on/off

Switching on

Press any button, with the following exceptions:

- ▷ Rear window heating.
- ▷ Seat heating.

Switching off



In the lowest setting, press the left of the button.

Temperature

Principle

The automatic air conditioning adjusts to the set temperature as quickly as possible, using maximum cooling or heating power if necessary. The temperature is then maintained.

Adjusting



Turn the wheel to select the desired temperature.

The automatic air conditioning regulates to this temperature as quickly as possible, using high cooling or heating power if necessary.

Avoid switching between different temperature settings in rapid succession. The automatic air conditioning will otherwise not have sufficient time to establish the temperature selected.

Cooling function

Principle

Interior air is cooled and dried, then reheated to suit the temperature setting.

The interior can only be cooled when the engine is running.

Switching on/off



Press the button.

The cooling function is switched on or off.

Depending on weather conditions, the windscreen and side windows may mist over for a short time when the engine is started.

The cooling function is switched on automatically in the AUTO program.

When the automatic air conditioning is in operation, condensation, see page 195, develops which exits underneath the vehicle.

Maximum cooling effect

Principle

System is set to lowest temperature, optimum air flow and recirculated-air mode.

General

The function is available above an outside temperature of approximately 0 °C/32 °F And with the engine running.

Switching on/off



Press the button.

The air flows from the side nozzles for the upper body area. Therefore open the side nozzles.

The air flow can be adapted when the programme is active.

AUTO program

Principle

The air flow, air distribution and temperature are automatically regulated.

Switching on/off



Press the button.

Depending on the selected temperature, intensity AUTO program and external influences, the air is directed towards the windscreen, side windows, upper body, and into the footwell.

The cooling function, see page 175, is switched on automatically in the AUTO program.

A condensation sensor also controls the programme so that window condensation is avoided as much as possible.

In the AUTO program, the air flow might be reduced during a telephone call using the hands-free system.

Intensity

With the AUTO programme switched on, the intensity can be adjusted. This changes the automatic control for the air flow and air distribution.



Press left or right side of button: reduce or increase intensity.

The selected intensity is shown on the display for automatic air conditioning.

Automatic air recirculation control, AUC/recirculated-air mode

Principle

Automatic air recirculation control AUC detects pollutants in the outside air. The supply of outside air is shut off and the interior air is recirculated.

General

When the system is activated, a sensor detects pollutants in the outside air and controls the shut-off automatically.

When the system is deactivated, outside air flows into the interior continuously.

Continuous recirculated-air mode deteriorates the air quality in the interior and condensation on the windows increases.

Switching on/off



Press the button repeatedly to call up an operating mode:

- ▷ LEDs off: ambient air is constantly entering the car.
- ▷ Left-hand LED on, AUC mode: a sensor detects pollutants in the outside air and shuts off the supply automatically.
- ▷ Right-hand LED on, recirculated-air mode: the ambient air supply is permanently shut off.

The recirculated-air mode automatically switches off at low outside temperatures after a given time, to avoid condensation.

If there is condensation on the window, switch off recirculated-air mode and press the AUTO button to use the condensation sensor. Ensure that air can flow towards the windscreen.

Adjusting the air flow manually

Principle

The air flow for air conditioning can be set manually.

General

To be able to adjust the air flow manually, first switch off the AUTO program.

Operation



Press left or right side of button: reduce or increase air flow.

The selected air flow is shown on the display for automatic air conditioning.

In order to protect the battery the air flow rate of the automatic air conditioning is reduced, if necessary.

Adjusting the air distribution manually

Principle

The air distribution for air conditioning can be set manually.

Operation



Press the button repeatedly to select a programme:

- ▷ Upper body area.
- ▷ Upper body area and footwell.
- ▷ Footwell.
- ▷ Windows and footwell: only on the driver's side.
- ▷ Windows, upper body area and footwell: only on the driver's side.

If there is condensation on the window, press the AUTO button in order to use the advantages of the condensation sensor.

Defrosting windows and removing condensation

Principle

Ice and condensation are quickly removed from the windscreen and the front side windows.

Switching on/off



Press the button.

The LED is illuminated when the system is switched on.

To do this, point the side nozzles at the side windows if necessary.

The air flow can be adapted when the programme is active.

If there is condensation on the window, switch on the cooling function as well or press the AUTO button to use the condensation sensor.

Rear window heating



Press the button. The LED is illuminated.

The rear window heating is switched off automatically after a certain period of time.

Microfilter/activated carbon filter

In outside and recirculated-air mode, the microfilter/activated carbon filter filters dust, pollen and harmful gases from the air.

Have this filter replaced during maintenance, see page 229, of the vehicle.

Ventilation

Ventilation at front

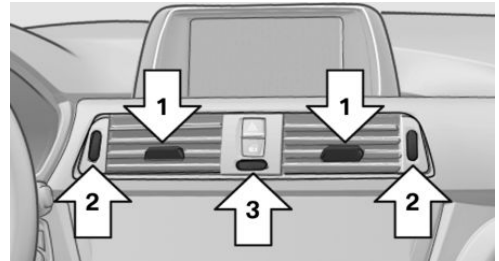

- ▷ Lever for changing the air flow direction, arrows 1.
- ▷ Knurled wheels to open and close the air outlets steplessly, arrow 2.
- ▷ Knurled wheel for varying ventilation temperature in upper body area, arrow 3.
Towards blue: cooler.
Towards red: warmer.

The set interior temperature for driver and front seat passenger is not changed by this.

Adjusting

- ▷ Ventilation for cooling:
Adjust the side nozzles so that air is directed towards you, for example if the vehicle's interior has become hot.
- ▷ Draught-free ventilation:
Adjust the side nozzles so that the air flows past you.

Ventilation in rear passenger compartment

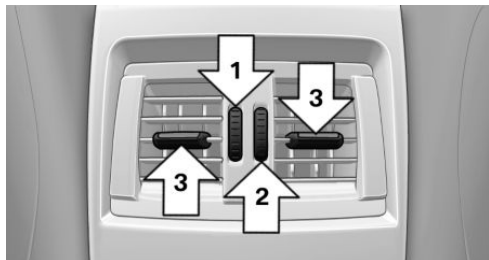

- ▷ Knurled wheel for steplessly opening and closing the side nozzles, arrow 1.
- ▷ Knurled wheel for varying the ventilation temperature, arrow 2.
Towards blue: cooler.
Towards red: warmer.
This does not change the set interior temperature.
- ▷ Lever for changing the air flow direction, arrow 3.

Independent ventilation

Principle

The independent ventilation system ventilates the passenger compartment and lowers its temperature where required.

General

The independent ventilation can be switched on and off via two preselected switch-on times or directly. The system remains switched on for 30 minutes.

The independent ventilation is operated using iDrive.

Operating requirements

- ▷ Direct operation: vehicle is in radio ready state.

- ▷ Direct operation or preselected switch-on time: does not depend on the outside temperature.
- ▷ Battery is sufficiently charged.
The vehicle battery is discharged when the independent ventilation is switched on. As a result, the maximum activation time is restricted to protect the battery. After the engine is started or after driving a short distance, the system will be available again.
- ▷ Ensure that the data and time are set correctly in the vehicle.
- ▷ Open the ventilation vents to allow the air to enter the passenger compartment.

Switching on/off directly

Via iDrive:

1. "My Vehicle"
2. "Vehicle settings"
3. If necessary, "Climate comfort"
4. "Activate auxiliary ventilation now"

⚡ symbol on automatic air conditioning flashes when system is switched on.

Preselecting the switch-on time

Via iDrive:

1. "My Vehicle"
2. "Vehicle settings"
3. If necessary, "Climate comfort"
4. "Auxiliary ventilation"
5. Select required switch-on time.
6. Set desired time.

Activating the switch-on time

Via iDrive:

1. "My Vehicle"
2. "Vehicle settings"
3. If necessary, "Climate comfort"
4. "For start time at:"

Activate required switch-on time.

 Symbol on the automatic air conditioning system is illuminated when the switch-on time is active.

 Symbol on the automatic air conditioning system flashes when the system has cut in.

The system switches on within the next 24 hours only. Afterwards, it must be reactivated.

Interior equipment

Vehicle equipment

This chapter describes all standard, national and special equipment available for the model series. Therefore equipment which is not installed in your vehicle, for example on account of the selected optional equipment or the country specification, may also be described here. This also applies to safety-relevant functions and systems. Comply with the relevant laws and regulations when using the corresponding functions and systems.

Sun visor

Glare protection

Fold the sun visor downwards or upwards.

Vanity mirror

A vanity mirror is situated in the sun visor behind a cover. The mirror light switches on when the cover is opened.

Ashtray/lighter

Ashtray

Opening

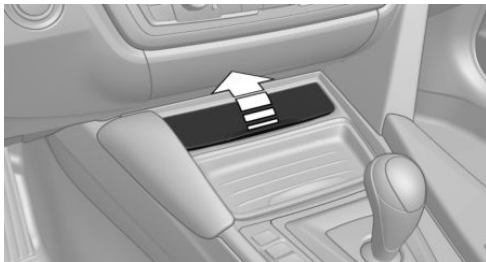

Remove lid.

Emptying

Lift out the insert.

Lighter



WARNING

Contacting the hot heating element or the hot fitting of the cigarette lighter can cause burns. Flammable materials can catch fire if the lighter falls down or is held against corresponding objects. There is a danger of fire and injury. Grip the cigarette lighter by the handle. Ensure that children do not use the lighter as there is a risk of burns. ◀



NOTE

If metallic objects fall into the socket, they can cause a short circuit. There is a danger of damage to property. After using the socket, put the lighter or socket cover back on. ◀



The cigarette lighter is located next to the ashtray.



Press in the cigarette lighter.

The cigarette lighter can be removed when it pops back out.

Power sockets

General

Cigarette lighter socket can be used as a socket for electrical devices when the engine is running or the ignition is switched on.

The total load of all sockets must not exceed 140 watt at 12 volt.

To avoid damage to the socket, do not insert an incompatible plug.

Safety notes



WARNING

Devices and cables, for example portable navigation devices, located in the deployment range of the airbags may impede airbag deployment or be flung around the vehicle interior when the airbag is deployed. There is a danger of injury. Make sure that devices and cables are not in the deployment range of the airbags. ◀



NOTE

Battery chargers for the vehicle battery can operate with high voltages and high currents, which can overload or damage the 12-volt on-board network. There is a danger of damage to property. Only connect battery chargers for the vehicle battery to the jump-starting connections in the engine compartment. ◀



NOTE

If metallic objects fall into the socket, they can cause a short circuit. There is a danger of damage to property. After using the socket, put the lighter or socket cover back on. ◀

Front centre console



Lift the lid and remove the cover or lighter.

Rear centre console



Remove the cover.

Inside the boot



Socket is on the left in the boot.

USB interface

Principle

Mobile devices with a USB port can be connected to the USB interface.

General

Comply with the notes on connecting mobile devices to the USB interface in the chapter on USB connections, see page 37.

In the centre armrest

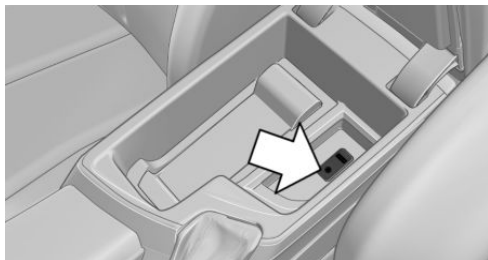

A USB interface is in the centre armrest.

In the centre console

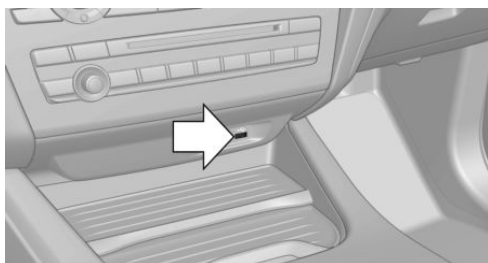

A USB interface is in the centre console.

Boot

Expanding the boot

Principle

The boot can be enlarged by folding down the rear backrest.

General

The rear backrest is split 60–40. The left-hand rear backrest is connected to the middle part.

The rear backrests can be folded down from the boot.

Safety notes



WARNING

Risk of trapping when folding down the rear backrest. There is a danger of injury or damage to property. Before folding down, make sure that the movement area of the rear backrest and the head restraint is clear. ◀



WARNING

If a rear seat backrest is not locked, unsecured cargo can be thrown into the interior, for example in the event of an accident or during braking or avoidance manoeuvres. There is a danger of injury. Make sure that the rear seat backrest is locked after it has been folded back. ◀



WARNING

If the seat adjustment or child seat installation is incorrect, the child restraint system may have limited stability or may not be stable at all. There is a danger of injury or even death. Make sure the child restraint system is firmly positioned against the backrest. Wherever possible, adapt the backrest angle of all the relevant seat backrests and adjust the seats correctly. Make sure that the seats and their backrests are correctly engaged. If possible, adjust the height of the head restraints, or remove them. ◀



NOTE

Vehicle parts can be damaged when folding down the rear backrest. There is a danger of damage to property. When folding down, make sure that the movement area of the rear backrest including head restraint is clear. ◀

Folding rear backrest down from the boot

1. Pull the corresponding lever in the boot to unlock the rear backrest.

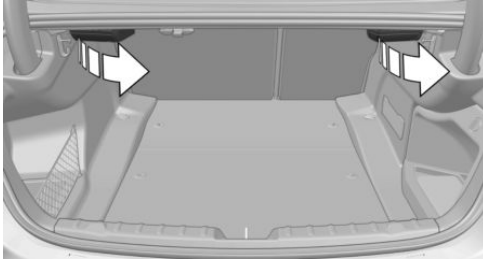

2. The unlocked rear backrest moves slightly to the front.
3. Fold the rear backrest forward.



Folding back the rear backrest

Fold the rear backrest back into seat position and engage.

Storage compartments

Vehicle equipment

This chapter describes all standard, national and special equipment available for the model series. Therefore equipment which is not installed in your vehicle, for example on account of the selected optional equipment or the country specification, may also be described here. This also applies to safety-relevant functions and systems. Comply with the relevant laws and regulations when using the corresponding functions and systems.

Safety notes

WARNING

Loose objects or devices connected by a cable to the vehicle, for example mobile telephones, can be thrown through the interior during the journey, for example in an accident or during braking and evasive manoeuvres. There is a danger of injury. Ensure that loose objects or devices connected by cable to the vehicle are secured in place in the interior. ◀

NOTE

Anti-slip mats can damage the dashboard. There is a danger of damage to property. Do not use anti-slip mats. ◀

Storage options

The following storage options are located in the interior:

- ▷ Glove box on the passenger side, see page 184.
- ▷ Glove box on the driver's side, see page 185.

- ▷ Without smoker's package: front storage compartment, in front of cupholders, see page 185.
- ▷ Storage compartment in the front centre armrest, see page 185.
- ▷ Pockets in the doors, see page 185.
- ▷ Nets on the backrests of the front seats.
- ▷ Storage compartment between the rear seats, see page 186.

Glove box

Front passenger's side

Safety note

WARNING

The glove box projects into the interior when it is opened. Objects in the glove box can be thrown into the interior during the journey, for example in an accident or during braking and evasive manoeuvres. There is a danger of injury. Immediately close the glove box after using it. ◀

Opening



Pull the handle.

The lighting in the glove box comes on.

Closing

Fold the cover up.

Locking

The glove box can be locked with an integrated key. This means it is not possible to access the glove box.

After the glove box has been locked, the remote control without the integrated key can be handed over, for example, at a hotel.

Driver's side

Safety note

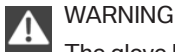

WARNING

The glove box projects into the interior when it is opened. Objects in the glove box can be thrown into the interior during the journey, for example in an accident or during braking and evasive manoeuvres. There is a danger of injury. Immediately close the glove box after using it. ◀

Opening



Pull the handle.

Closing

Fold the cover up.

Front storage compartment

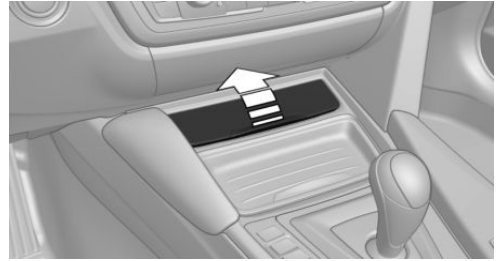

Lift lid to open.

Pockets in the doors



WARNING

Fragile objects, for example glass bottles or glasses, can break in the event of an accident. Shards can spread throughout the interior. There is a danger of injury. Do not use any fragile objects while driving. Only stow fragile objects in lockable storage compartments. ◀

Centre armrest

Front

General

There is a storage compartment in the centre armrest between the front seats.

Opening

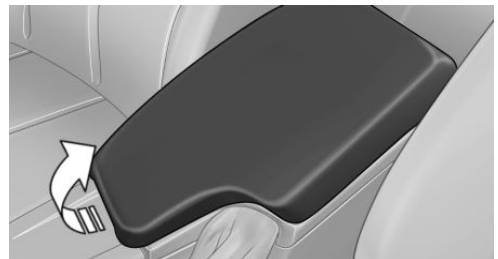

Fold the centre armrest upwards.

Sliding

The centre armrest can be slid in the longitudinal direction and engages in the end positions.

Connection for external audio device



An external audio device, for example an MP3 player, can be connected via the USB audio interface in the centre armrest.

Storage compartment between the rear seats

A storage compartment is located between the rear seats.

Cupholder

Safety note



WARNING

Unsuitable containers in the cupholder and hot drinks can damage the cupholders, and increase the risk of injury in an accident. There is a danger of injury or damage to property. Use lightweight, lockable containers that are shatterproof. Do not transport hot drinks. Do not force objects into the cupholder. ◀

Front



Fittings for front cupholders

With the fitting, the cupholders can be used as an extra storage compartment. To do this, put the fittings into the cupholder.

Only use fittings for small object, for example a key or remote control.

Coat hooks

Safety notes



WARNING

Items of clothing on the coat hooks can impair visibility when driving. There is a danger of accidents. Hang items of clothing from the hooks so they do not obstruct visibility when driving. ◀



WARNING

Incorrect use of the coat hooks can present a danger, for example if objects are flung around in the event of braking and evasive manoeuvres. There is a danger of injury and damage to property. Only hang lightweight objects, for example items of clothing, on the coat hooks. ◀

General

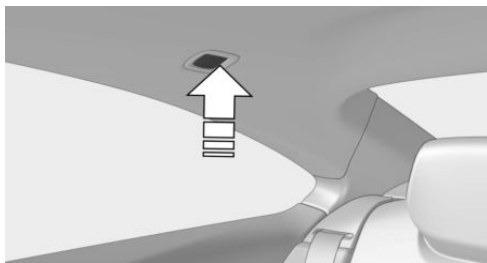

To open, press top edge.

Storage compartments in the boot

Storage compartment

There is a storage compartment on the left.

There is a storage compartment on the right.

Net

Smaller objects can be stowed in the net on the left-hand side.

Bag holders

Note



WARNING

If the holders are used incorrectly, items may be flung around in the event of braking or evasive manoeuvres. There is a danger of injury and damage to property. Only hang light objects, for example shopping bags, on the holders. Only transport heavy luggage in the boot if suitably secured. ◀

Overview

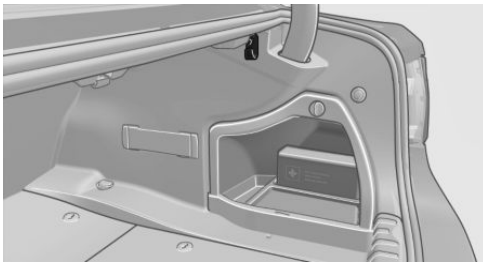

In the boot there is a bag holder on each side.

Lashing eyes in the boot

For securing the load, see page 196, four lashing eyes are in the boot.

Floor net

The floor net can also be used for securing the load, see page 196.

Storage compartment under the boot floor

For the storage compartment under the boot floor, do not exceed a maximum permitted load of 20 kg, approximately 44 lb.

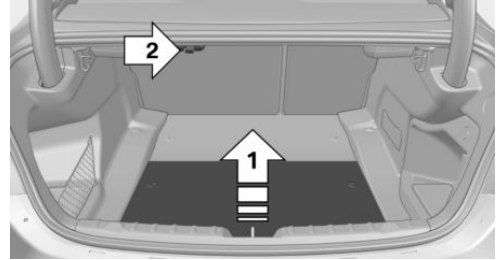

Lift the boot floor, arrow 1, and engage upwards, arrow 2, as needed.



Driving hints

The chapter provides you with information that you may require in particular driving situations or operating modes.

BMW M4 Technology

Vehicle equipment

This chapter describes all standard, national and special equipment available for the model series. Therefore equipment which is not installed in your vehicle, for example on account of the selected optional equipment or the country specification, may also be described here. This also applies to safety-relevant functions and systems. Comply with the relevant laws and regulations when using the corresponding functions and systems.

High performance engine

General

The high power engine generates a maximum power of 317 kW, with Competition package 331 kW and a maximum torque of 550 Nm from 3 litres of capacity.

The maximum power for the M4 CS is 338 kW and the maximum torque 600 Nm.

The spontaneous responsiveness of the high-performance engine produces a very broad usable engine speed range. The maximum engine speed is electronically regulated at 7600 rpm. Due to the powerful engine dynamics, the maximum engine speed is limited when the vehicle is stationary.

Driving hot

During the engine warm-up phase, the high performance engine runs slightly more roughly due to the emission control.

When the engine is cold, the exhaust has a slightly metallic undertone, depending on the system.

Other information for hot driving: engine speed counter, see page 105, and engine oil temperature, see page 106.

M compound brakes

The high performance brake system has ventilated compound brake discs.

Depending on design requirements, function noises may occur when braking. The functional noises have no effect on the efficiency, operational safety and endurance of the brake.

Braking correctly

To keep the brake system in optimum condition, it is desirable to load them at regular intervals depending on the nature of the vehicle.

M Carbon ceramic brakes

The high performance brake system has ventilated carbon-ceramic brake discs.

Depending on the material-specific properties, there can be increased functional noises when braking, particularly when it is wet, shortly before the vehicle comes to a stop. Increased functional noises have no effect on the efficiency, operational safety and endurance of the brake.

Due to the effect of wetness and salt spray, for example, after using a car wash, condensation overnight, driving in rain etc., the braking effect may correspond to a conventional braking system. The braking effect may be perceived to be reduced and can be compensated for by greater pedal pressure, as needed.

First clean brake discs and callipers with a steam cleaner or high-pressure cleaner before washing the vehicle in an automatic washing bay or car wash. This prevents salt crystals, for example, from causing crusty deposits and build-up to form if the vehicle then remains stationary for a period of time. The cleaning effect of automatic car washes generally not sufficient for this in the wheel area.

Also follow the information on this under vehicle washing, see page 244, and safe braking, see page 194.

Drivetrain

In this vehicle, particular attention is paid to the direct connection from the engine to the drivetrain. Due to the torsionally stiff design of the drivetrain, as usual in a sports car, the transmission of the torque is can also be heard.

When there are load changes, it can therefore cause clattering noises. The clicking noises do not affect the function or lifetime of the components.

Driving on a racing track

The higher mechanical and thermal loads involved in driving on racing tracks lead to increased wear. This wear is not covered by the warranty. The vehicle is not conceived for use in motor sports competitions.

Before driving on a racing track, have the vehicle checked at a Service Partner of the manufacturer or another qualified Service Partner or a specialist workshop.

The standard brake pads and the wear displays are not designed for racing track operation.

Further information and advice can be obtained from a Service Partner of the manufacturer or another qualified Service Partner or a specialist workshop.

Driving precautions

Vehicle equipment

This chapter describes all standard, national and special equipment available for the model series. Therefore equipment which is not installed in your vehicle, for example on account of the selected optional equipment or the country specification, may also be described here. This also applies to safety-relevant functions and systems. Comply with the relevant laws and regulations when using the corresponding functions and systems.

Running in

General

Moving parts must adapt to one another.

The following notes will help to maximise the vehicle's lifetime and efficiency.

Do not use Launch Control when running in.

Safety note



WARNING

New parts and components can cause safety and Driver Assistance Systems to respond with a delay. There is a danger of accidents. After new parts have been installed, or if the vehicle is new, drive moderately and intervene at an early stage if necessary. Comply with running-in procedures for the corresponding parts and components. ◀

Engine, gearbox and differential

Up to 2000 km, 1200 miles

Drive with alternating revolutions and speeds, but do not exceed 5500 rpm and 170 km/h, approximately 106 mph.

Generally avoid kick-down and driving under full load.

At 2000 km, 1200 miles

Have maintenance conduct a drive-in service.

From 2000 km, approximately 1200 miles to 5000 km, approximately 3100 miles

Revolutions and vehicle speed can gradually be increased to a continuous speed of 220 km/h, approximately 137 mph.

The maximum speed of 250 km/h, approximately 155 mph is only to be used briefly, for example when overtaking.

Tyres

New tyres do not achieve their full road grip immediately, for production reasons.

During the first 300 km, approximately 200 miles, drive moderately.

Brake system

Brake discs and pads of the M Compound brake only achieve their full effectiveness after approx. 500 km, approx. 300 miles. Drive moderately during this running-in period.

Brake discs and pads of the M Carbon ceramic brake only achieve their full effectiveness after approx. 1000 km, approx. 600 miles. Drive moderately during this running-in period.

Clutch

The clutch only begins to function optimally at approximately 500 km, approximately 300 miles. Engage the clutch gently during this running-in period.

After fitting new parts

The same running-in procedures should be observed if any of the components mentioned above have to be renewed in the course of the vehicle's operating life.

General driving information

Closing the boot lid

Safety note

 **WARNING**
When open, the boot lid protrudes above the vehicle, and in the event of an accident, braking or avoidance manoeuvres, it can endanger vehicle occupants and other road users, or damage the vehicle. There is also the danger of exhaust fumes entering the interior of the vehicle. There is a danger of injury or damage to property. Do not drive with the boot lid open. ◀

Driving with the tailgate open

If there is no alternative to driving with the tailgate open:

- ▷ Close all the windows and the Glass Roof.
- ▷ Turn up the blower to a high output level.
- ▷ Maintain moderate speed.

Hot exhaust system

 **WARNING**
During driving, high temperatures can be generated under the body, for example because of the exhaust system. If flammable materials, for example leaves or grass, come into contact with hot parts of the exhaust system, these materials can catch fire. There is a danger of injury or damage to property. Never remove the heat shields fitted here, or apply underseal to them. Make sure that when driving, idling or parking, no flammable materials can come into contact with hot vehicle parts. Do not touch the hot exhaust system. ◀

Radio signals

 **WARNING**
Certain vehicle functions may be affected by interference from high-frequency radio signals. Such signals originate from various transmission systems, for example, from air traffic beacons or relay stations for mobile telecommunications.

We recommend you consult a Service Partner should you experience any difficulties in this regard. ◀

Mobile communication in the vehicle

 **WARNING**
There is a possibility of interference between the vehicle electronics and mobile radio devices. The radiation arises when mobile radio devices are transmitting. There is a danger of injury or damage to property. If possible, only use mobile radio devices, for example mobile telephones, in the interior with direct connection to an external antenna to exclude mutual interference and to dissipate the radiation from the vehicle's interior. ◀

Aquaplaning

On wet or slushy roads, a wedge of water can form between the tyres and the road.

This situation, known as aquaplaning, means that the tyre can actually lose contact completely with the road surface and the vehicle can neither be steered nor the brakes properly applied.

Wading

General

Comply with the following when driving through water:

- ▷ Only drive through calm water.
- ▷ Only drive through water up to a max. depth of 25 cm, approximately 9.8 in.

- ▷ Drive through water at no faster than 5 km/h, approximately 3 mph.

Safety note



NOTE

Driving through excessively deep water too fast can result in water entering the engine compartment, electrical system or transmission. There is a danger of damage to property. When driving through water, do not exceed the maximum specified water depth and maximum fording speed. ◀

Safe braking

The vehicle is equipped with ABS as standard. Perform full braking in situations that require it. The vehicle can be steered. Any obstacles can be avoided by performing steering movements as smoothly as possible.

A pulsing of the brake pedal shows that ABS is regulating.

In certain braking situations, the perforated brake discs can cause functional noise. Functional noises have no effect on the efficiency and operational safety of the brakes.

Objects in the range of movement of the pedals and in the footwell



WARNING

Objects in the driver's footwell can restrict the pedal travel, or block a pedal that has been pressed. There is a danger of accidents. Stow items in the vehicle so that they are secure and cannot get into the driver's footwell. Only use floor mats that are appropriate for the vehicle and can be securely fastened to the floor. Do not use any loose floor mats, and do not place several floor mats on top of one another. Make sure that there is sufficient space for the pedals. Ensure that the floor mats are securely reattached after having been removed, for example for cleaning. ◀

Wet roads

In damp weather, if road grit has been spread or there is heavy rain, apply the brakes lightly every few kilometres/miles.

In doing so, do not obstruct other road users.

The heat generated by braking dries the brake discs and brake pads, and protects them against corrosion.

This way, brake power is available immediately, whenever it is needed.

Downhill gradients

General

When driving on long or steep downhill stretches, use the gear in which the least braking is required. Otherwise the brake system can overheat and braking effect is reduced.

Manual gearbox:

The braking effect can be additionally increased by shifting down, even into first gear, if applicable.

M double clutch transmission:

The braking action of the engine can be boosted further by shifting down in Sequential mode, see page 97.

Safety notes



WARNING

Even slight, continuous pressure on the brake pedal can cause overheating, brake pad wear or even brake system failure. There is a danger of accidents. Avoid excessive loads on the brake. ◀



WARNING

When idling or with the engine switched off, safety-relevant functions are restricted or no longer available, for example the braking effect of the engine or power assistance for the braking force and steering. There is a danger of accidents. Do not drive at idle speed or with the engine switched off. ◀

Corrosion of the brake disc

Corrosion of the brake discs and contamination of the brake pads increase in the following circumstances:

- ▷ Low mileage.
- ▷ Extended periods when the vehicle is not used.
- ▷ Infrequent use of the brakes.
- ▷ Aggressive, acidic or alkaline cleaning agents.

Should corrosion form on the brake discs, the brakes will tend to respond with a pulsating effect that generally cannot be corrected.

Condensation when vehicle is parked

When the automatic air conditioning is in operation, condensation develops which exits underneath the vehicle.

Ground clearance



NOTE

If there is insufficient ground clearance, the front or rear spoiler can contact the ground, for example at curb edges or when driving into underground car parks. There is a danger of damage to property. Make sure that there is sufficient ground clearance. ◀

When driving down from kerb edges, select the following programme with the adaptive M suspension, see page 153, to keep the ground clearance as uniform as possible. "Sport Plus"

M Driver's Package: driving in maximum speed range



WARNING

At high speeds, damage to vehicle parts can adversely affect vehicle handling characteristics. Such parts include the tyres, underbody and parts for improving aerodynamics. There is a danger of accidents. Have the damage rectified by a Service Partner of the manufacturer or another qualified Service Partner or

a specialist workshop. Do not drive at high speed until the damage has been repaired. ◀

Loads

Vehicle equipment

This chapter describes all standard, national and special equipment available for the model series. Therefore equipment which is not installed in your vehicle, for example on account of the selected optional equipment or the country specification, may also be described here. This also applies to safety-relevant functions and systems. Comply with the relevant laws and regulations when using the corresponding functions and systems.

Safety notes

WARNING

A high gross vehicle weight can cause the tyres to overheat, causing internal damage and a sudden loss of tyre inflation pressure. The driving characteristics can be negatively influenced, for example reduced directional stability, longer braking distance and modified steering characteristics. There is a danger of accidents. Comply with the permitted load index of the tyre, and do not exceed the permitted gross vehicle weight. ◀

WARNING

If the permitted total weight and the permitted axle loads are exceeded, the operational safety of the vehicle is no longer guaranteed. There is a danger of accidents. Do not exceed the permitted total weight and permitted axle loads. ◀

WARNING

Loose objects or devices connected by a cable to the vehicle, for example mobile telephones, can be thrown through the interior during the journey, for example in an accident or during braking and evasive manoeuvres. There is a danger of injury. Ensure that loose

objects or devices connected by cable to the vehicle are secured in place in the interior. ◀

WARNING

Incorrectly stowed objects can slip or be thrown into the interior, for example in an accident, during braking or evasive manoeuvres. Vehicle occupants could be hit and injured. There is a danger of injury. Stow and secure the objects and the load correctly. ◀

NOTE

Liquids in the boot may cause damage. There is a danger of damage to property. Ensure that no liquids leak out into the boot. ◀

Stowing and securing a transported load

- ▶ Wrap protective material around any sharp corners and edges on the load.
- ▶ Heavy transported loads: stow as far forward and as low down as possible, ideally directly behind the rear backrests.
- ▶ Very heavy transported loads: if there are no passengers on the back seat, insert both outer seat belts into the respective opposite buckles.
- ▶ Fully fold down the rear backrests if the load is to be stowed accordingly.
- ▶ Do not stack load items above the upper edge of the backrests.
- ▶ Smaller and light transported load: secure with tensioning straps, the floor net or other suitable straps.
- ▶ Larger and heavy transported loads: secure with lashing straps.

Lashing eyes in the boot

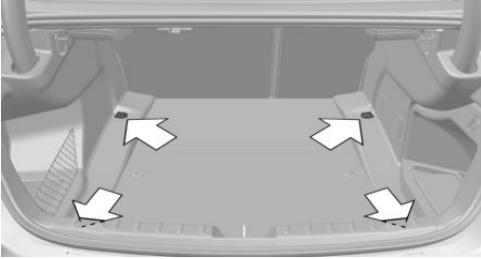

Four lashing eyes are located in the boot for securing the load.

Equipment for securing the transported load, such as lashing straps, tensioning straps or luggage nets, must be secured to the lashing eyes in the boot.

Floor net

The floor net can also be used for securing the load.

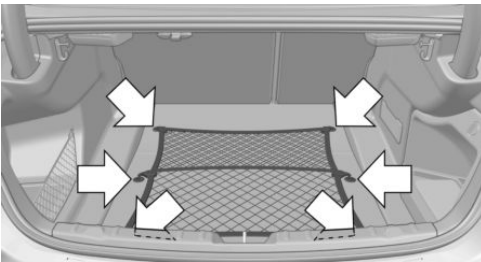

Hang the floor net on the eyes in the boot floor.

Roof rack

General

Roof racks are available as special equipment.

Safety note



WARNING

When driving with a roof load, for example with a roof rack, the higher centre of gravity can mean that driving safety is no longer guaranteed in critical driving situations. There is a danger of accident or damage to property. Do not deactivate Dynamic Stability Control DSC when driving with a roof load. ◀

Fastening

Follow the installation instructions for the roof rack.

Roof strip with flaps



The mounting points are located on the roof strip above the doors.

Fold the cover outwards.

Loads

A loaded roof rack alters the vehicle's road behaviour and steering response by shifting its centre of gravity.

When loading and driving, bear the following in mind:

- ▷ Do not exceed the permitted roof and axle loads or the permitted gross weight.
- ▷ Make sure that there is sufficient space to raise and open the Glass Roof.
- ▷ Distribute the roof load evenly.
- ▷ The roof load must not be spread over a large area.

- ▷ Place heavy items of luggage at the bottom.
- ▷ Securely fasten the luggage, for example with tensioning straps.
- ▷ Do not allow objects to protrude into the swing range of the boot lid.
- ▷ Drive cautiously and avoid sudden acceleration, braking or cornering.

Saving fuel

Vehicle equipment

This chapter describes all standard, national and special equipment available for the model series. Therefore equipment which is not installed in your vehicle, for example on account of the selected optional equipment or the country specification, may also be described here. This also applies to safety-relevant functions and systems. Comply with the relevant laws and regulations when using the corresponding functions and systems.

General

The vehicle possesses wide-ranging technologies for reducing consumption and emission levels.

Fuel consumption depends on various factors.

A number of measures, such as a moderate driving style and regular maintenance, can influence fuel consumption and reduce burden on environment.

Remove transported load that is not required

Extra weight increases fuel consumption.

Remove add-on parts after use

Remove unneeded roof racks after use.

Add-on parts on the vehicle interfere with its aerodynamic performance and increase fuel consumption.

Closing windows and the Glass Roof

An opened Glass Roof or opened window increases the drag and thus reduces the range.

Tyres

General

Tyres can have differing effects on fuel consumption. For example, fuel consumption can be affected by tyre size.

Checking tyre inflation pressure regularly

Check and, if necessary, correct tyre inflation pressures at least twice a month and before setting off on a longer journey.

Insufficient tyre inflation pressure increases rolling resistance and consequently fuel consumption and tyre wear.

Drive off immediately

Do not warm up the engine with the vehicle at a standstill; it is preferable to set off straight away, driving at moderate engine speeds.

This brings the cold engine to operating temperature as quickly as possible.

Drive with foresight

Anticipating the road situation and adopting a smooth driving style will reduce fuel consumption.

Avoid accelerating and braking unnecessarily. Keep an appropriate distance from the preceding vehicle.

Avoid high engine speeds

Driving at low engine speeds lowers fuel consumption and wear.

Pay attention to the shift point indicator, see page 110, in the vehicle, if fitted.

Make use of overrun mode

When approaching a red traffic light, take your foot off the accelerator and allow the vehicle to roll.

On downward stretches, take your foot off the accelerator and allow the vehicle to roll.

The fuel supply is interrupted in overrun mode.

Switch off the engine if stopping for a relatively long time

Stopping the engine

When you stop the vehicle for longer periods, for example at traffic lights, railway crossings or in traffic jams, switch off the engine.

Auto Start Stop function

The Auto Start Stop function of the vehicle shuts off the engine automatically during a stop.

If the engine is switched off and then started again, the fuel consumption and emissions are reduced compared with a permanently running engine. Savings can be made just by stopping the engine for a few seconds.

Fuel consumption also depends on other factors, such as driving style, road condition, maintenance or environmental factors, for example.

Switch of functions which are not currently required

Functions such as seat heating or rear window heating require a great deal of energy and reduce the range, especially in city traffic and stop-and-go traffic.

Switch these functions off if they are not required.

Have the maintenance done

Have the vehicle serviced regularly to achieve optimal economy and lifetime. BMW recommends having maintenance work carried out by a BMW Service Partner.

Please also see the BMW Maintenance System, see page 229.

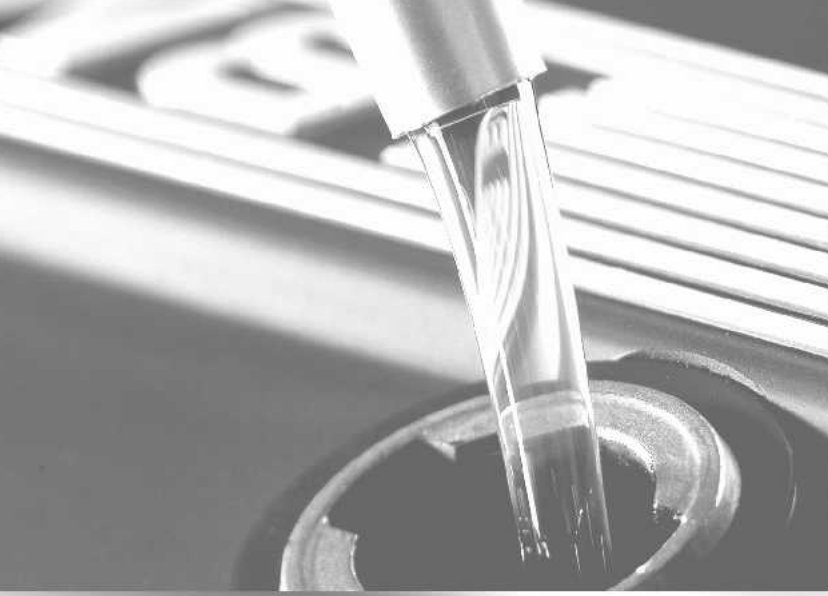



Mobility

To assist you in preserving your vehicle's mobility, this section contains important information on operating fluids, wheels and tyres, maintenance and breakdown assistance.

Refuelling

Vehicle equipment

This chapter describes all standard, national and special equipment available for the model series. Therefore equipment which is not installed in your vehicle, for example on account of the selected optional equipment or the country specification, may also be described here. This also applies to safety-relevant functions and systems. Comply with the relevant laws and regulations when using the corresponding functions and systems.

General

Before refuelling, observe notes on fuel quality, see page 206.

Safety note



NOTE

If the range drops below 50 km, approximately 30 miles, the engine may no longer be supplied with sufficient fuel. Engine function is no longer ensured. There is a danger of damage to property. Refuel in good time. ◀

Fuel tank cap

Opening

1. Briefly press the rear edge of the fuel filler flap.



2. Turn the fuel tank cap anticlockwise.

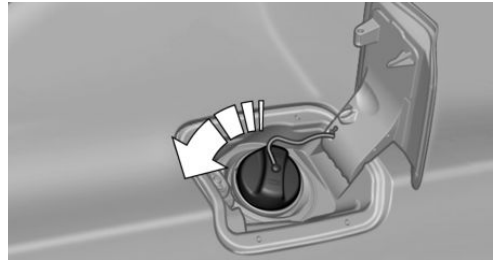

3. Place the fuel tank cap in the holder on the fuel filler flap.

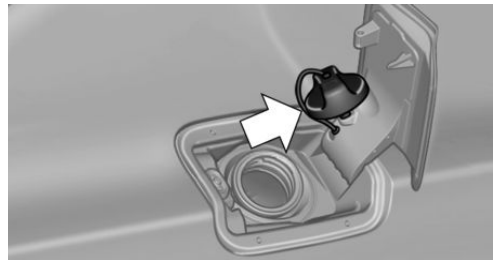

Closing



WARNING

The retaining strap of the fuel tank cap may become trapped and crushed when turning the cap to close it. It will then not be possible to close the cap properly. Fuel or fuel vapours can leak out. There is a danger of injury or damage to property. Make sure that the retaining strap does not get trapped and crushed when closing the cap. ◀

1. Fit the tank cap and turn clockwise until it is clearly heard to click into place.
2. Close the fuel filler flap.

Unlocking the fuel filler flap manually

For example, if there is an electrical fault.

Have the fuel filler flap unlocked by a Service Partner of the manufacturer or another qualified Service Partner or a specialist workshop.

Note when refuelling

General

When refuelling, insert the filler nozzle fully into the filler neck. Lifting the filler nozzle during refuelling results in the following:

- ▶ The fuel supply being cut off prematurely.
- ▶ Fuel vapour and fumes being fed back less effectively.

The fuel tank is full when the filler nozzle cuts out for the first time.

Comply with the safety regulations displayed at filling stations.

Safety note



NOTE

Fuels are poisonous and aggressive. Overfilling the fuel tank can damage the fuel system. If fuel comes into contact with painted surfaces, it can damage them. This pollutes

the environment. There is a danger of damage to property. Avoid overfilling. ◀

Fuel

Vehicle equipment

This chapter describes all standard, national and special equipment available for the model series. Therefore equipment which is not installed in your vehicle, for example on account of the selected optional equipment or the country specification, may also be described here. This also applies to safety-relevant functions and systems. Comply with the relevant laws and regulations when using the corresponding functions and systems.

Fuel quality

General

Depending on the region, many filling stations sell fuel that is adapted to the conditions in winter or summer. Fuel that is sold in winter facilitates cold starting, for example.

Petrol

General

For optimal fuel consumption, the petrol should be sulphur-free or low in sulphur content.

Fuels labelled on the pump as containing metal must not be used.

You can fill up with fuels with a maximum proportion of ethanol of 10 %, in other words E10.

The engine has anti-knock control. This means that different petrol grades can be used.

Safety notes



NOTE

Even small quantities of the wrong fuel or wrong fuel additives can damage the fuel system and engine. In addition, the catalytic converter will be permanently damaged. There is a

danger of damage to property. Do not use the following fuel or additives with petrol engines:

- ▷ Leaded petrol.
- ▷ Metallic additives, for example manganese or iron.

After filling the wrong fuel, do not press the start/stop button. Contact a Service Partner of the manufacturer or another qualified Service Partner or a specialist workshop. ◀



NOTE

Incorrect fuels can damage the fuel system and engine. There is a danger of damage to property. Do not refuel with fuel with a higher proportion of ethanol than recommended. Do not refuel with fuel containing methanol, for example M5 to M100. ◀



NOTE

Fuel below the specified minimum quality can impact the engine function or lead to engine damage. There is a danger of damage to property. Do not refuel with petrol below the specified minimum quality. ◀

Petrol grade

Super Plus, RON 98.

Fill up this fuel so that the nominal performance data values and consumption is achieved.

Minimum grade

Super, RON 95.

BMW M recommends **Shell V-Power** 

Wheels and tyres

Vehicle equipment

This chapter describes all standard, national and special equipment available for the model series. Therefore equipment which is not installed in your vehicle, for example on account of the selected optional equipment or the country specification, may also be described here. This also applies to safety-relevant functions and systems. Comply with the relevant laws and regulations when using the corresponding functions and systems.

Tyre inflation pressure

General

A tyre's condition and inflation pressure influence the following:

- ▷ Lifetime of the tyre.
- ▷ Driving safety.
- ▷ Driving comfort.
- ▷ Fuel consumption.

Safety note



WARNING

A damaged tyre with too low tyre inflation pressure, or no pressure at all impairs driving properties, for example steering and braking. There is a danger of accidents. Check the tyre inflation pressure regularly and adjust as necessary, for example twice a month or before any long journey. ◀

Checking the tyre inflation pressure

General

Only check the tyre inflation pressure when the tyres are cold, i.e.:

- ▷ A driving distance of max. 2 km, 1.25 miles has not been exceeded.
- ▷ If the vehicle has not moved again for at least 2 hours after a journey.

The tyre inflation pressure data only relates to cold tyres or tyres at the same temperature as the ambient temperature.

Tyres heat up while driving. The tyre inflation pressure increases with the temperature of the tyre.

Inflating devices can display a pressure as much as 0.1 bar too low.

Tyres have a natural, uniform loss of tyre inflation pressure.

Check whether all valve caps are screwed onto the tyre valves.

After adjusting the tyre inflation pressure

For the runflat indicator RPA: reinitialise the runflat indicator RPA.

For the Tyre Pressure Monitor TPM: reset the Tyre Pressure Monitor TPM.

Tyre inflation pressure information

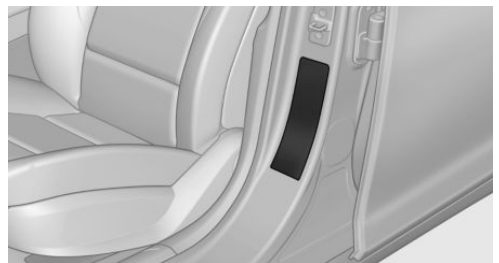

The tyre inflation pressures are shown on the door pillar of the driver door. The tyre inflation pressure data applies to the tyre sizes categorised by the vehicle manufacturer as suitable and the tyre makes recommended for the respective vehicle type.

If the tyre's speed code cannot be found, then the tyre inflation pressure for the corresponding tyre size applies.

More information regarding wheels and tyres can be obtained from a Service Partner of the manufacturer or another qualified Service Partner or a specialist workshop.

For Australia/New Zealand



WARNING

The inflation pressures on the tyre label are applicable only for tyres explicitly mentioned on the label. Since tyre inflation pressures for tyres that may be covered by the label – by size, speed category and load rating/load index – but not explicitly mentioned on the label may be different. Please obtain adequate inflation pressures in accordance with the tyre manufacturer's specifications at your tyre dealer. ◀

Speed code letter

Q = up to 160 km/h/100 mph

R = up to 170 km/h/106 mph

S = up to 180 km/h/112 mph

T = up to 190 km/h/118 mph

H = up to 210 km/h/131 mph

V = up to 240 km/h/150 mph

W = up to 270 km/h/167 mph

Y = up to 300 km/h/186 mph

Tyre tread

Summer tyres

The tyre tread depth should not be less than 3 mm, 0.12 in, otherwise there is a high risk of aquaplaning.

Winter tyres

The tyre tread depth should not be less than 4 mm, 0.16 in, otherwise the vehicle's suitability for winter use is restricted.

Minimum tread depth

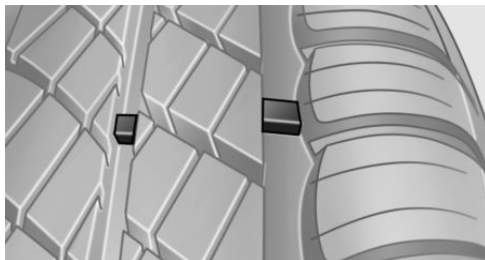

Wear displays are distributed across the tyre circumference and have the legally prescribed minimum height of 1.6 mm, approximately 0.06 in.

The positions of the wear displays are identified on the tyre's side wall by TWI, Tread Wear Indicator.

Tyre damage

General

Inspect tyres regularly for damage, the presence of foreign bodies and wear.

Vehicle behaviour that may indicate tyre damage or other faults:

- ▷ Unusual vibrations.
- ▷ Unusual tyre or running noises.
- ▷ Unusual vehicle response, such as pronounced pulling to the left or right.

Damage can be caused by the following situations, for example:

- ▷ Driving over kerbs.
- ▷ Road damage.
- ▷ Tyre inflation pressure too low.
- ▷ Vehicle overloading.

- ▷ Incorrect tyre storage.

Safety notes



WARNING

If the tyres are damaged, the tyre inflation pressure may be reduced which in turn could cause you to lose control of the vehicle. There is a danger of accidents. If you receive a message indicating tyre damage while you are driving, immediately reduce speed and bring the vehicle to a stop. Have the wheels and tyres checked. To do so, carefully drive to a Service Partner of the manufacturer or another qualified Service Partner or a specialist workshop. If necessary, have the vehicle towed or transported there. ◀



WARNING

If the tyres are damaged, the tyre inflation pressure may be reduced which in turn could cause you to lose control of the vehicle. There is a danger of accidents. Do not repair damaged tyres, have them renewed instead. ◀



WARNING

Tyres can become damaged by running over obstacles, for example kerbs or road damage, at high speed. Larger wheels have a smaller tyre cross-section. The smaller the tyre cross-section, the higher the risk of tyre damage. There is a danger of accidents and damage to property. If possible, drive around obstacles, or drive over them slowly and carefully. ◀

Age of tyres

Recommendation

Irrespective of the tyre tread depth, change the tyres after 6 years at the latest.

Date of manufacture

The date of manufacture of the tyre is indicated on the tyre sidewall.

Designation	Date of manufacture
DOT ... 2117	21st week of 2017

Replacement of wheels and tyres

Fitting

Have the wheel fitted and balanced by a Service Partner of the manufacturer or another qualified Service Partner or a specialist workshop.

Wheel/tyre combination

General

Information on the correct wheel/tyre combination and rim designs for the vehicle can be obtained from a Service Partner of the manufacturer or another qualified Service Partner or a specialist workshop.

Incorrect wheel/tyre combinations will interfere with the proper functioning of various systems, such as ABS or DSC.

To maintain good vehicle handling, always fit tyres of the same make and tread pattern to all wheels.

After a tyre has been damaged, ensure that the original wheel/tyre combination is re-created.

Safety note



WARNING

Wheels and tyres that are not suitable for your vehicle can damage parts of the vehicle. For example they could come into contact with the bodywork on account of their tolerances, despite having the same nominal size. There is a danger of accidents. The manufacturer of the vehicle recommends using wheels and tyres that have been categorised as suitable for the respective vehicle type. ◀

Recommended makes of tyre



Certain makes of tyre are recommended by the manufacturer of the vehicle for each tyre size. The tyre brands can be identified by a star on the side wall of the tyre.

New tyres

New tyres do not achieve their full road grip immediately, for production reasons.

During the first 300 km, approximately 200 miles, drive moderately.

Retreaded tyres

The manufacturer of your vehicle advises against the use of retreaded tyres.



WARNING

Retreaded tyres may have different tyre carcasses. Their durability may be reduced with increasing age. There is a danger of accidents. Do not use retreaded tyres. ◀

Winter tyres

For operation on wintry carriageways, winter tyres are recommended.

Although so-called all-season tyres with an M+S label have better winter characteristics than summer tyres, they do not normally match the performance of winter tyres.

Maximum speed of winter tyres

If the vehicle is capable of maximum speeds higher than the speed permitted for the winter tyres, display an indicating label stating the

maximum permitted speed in the driver's field of view. The indicating label is available from a Service Partner of the manufacturer or another qualified Service Partner or a specialist workshop.

If winter tyres are fitted, observe and do not exceed the respectively permitted maximum speed.

Interchanging front and rear wheels

The manufacturer of your vehicle advises against interchanging the front and rear wheels. This could impair vehicle handling.

A wheel change from one axle to another is not permitted in vehicles with different tyre or rim dimensions on the front and rear axles.

Storing tyres

Air pressure

Do not exceed the maximum tyre inflation pressure indicated on the tyre's side wall.

Tyre storage

Store wheels and tyres in a cool, dry and dark place when not in use.

Protect the tyres against contamination from oil, grease and solvents.

Do not leave the tyres in plastic bags.

Remove dirt from the wheels or tyres.

Remedying flat tyres

Safety measures

- ▷ Park the vehicle on a solid surface and as far away from moving traffic as possible.
- ▷ Switch on the hazard warning lights.
- ▷ Protect the vehicle against rolling, by applying the parking brake.
- ▷ Engage the steering wheel lock with the wheels in the straight-ahead position.

- ▶ Have all vehicle occupants get out of the vehicle and guide them out of the danger area, for example behind the crash barrier.
- ▶ Set up the warning triangle an appropriate distance away.

M4 CS sport tyres

General

The vehicle is fitted with sport tyres, which have been optimised for use on a racing track in dry conditions.

More information on wheels and tyres:

- ▶ From a Service Partner of the manufacturer or another qualified Service Partner or a specialist workshop.
- ▶ Internet: www.michelin.com

Safety note



WARNING

At temperatures below -10 °C/14 °F, the sport tyres can become damaged, for example torn and broken. There is a danger of accident or damage to property. Do not move, fit or drive on sport tyres at temperatures below -10 °C/14 °F. ◀

Tyre storage

- ▶ If the sport tyres are not used for a long period of time, we recommend removing the wheels from the vehicle and lowering the tyre inflation pressure to half the level specified by the manufacturer.
- ▶ Store wheels or sport tyres in a clean, dry and dark place at temperatures above 0 °C/32 °F.

Use on the road

The sport tyres meet the legal regulations for use on public roads.

After being used on a racing track, the sport tyres may no longer be suitable for road use.

Therefore, after they have been used on a racing track, check the sport tyres against the legal regulations for use on public roads, for example the minimum tread depth.

Use on a racing track

General

Inspect the sport tyres for damage, the presence of foreign bodies and wear every time before using them on a racing track.

Bring the sport tyres to the correct temperature for use on a racing track. To do this, drive a few circuits with an appropriate driving style.

Intensive use

After an extended period of intensive driving on a racing track and driving over kerbs or leaving the carriageway, the sport tyres can become damaged.

Inspect the sport tyres for damage, the presence of foreign bodies and wear. The wheel must be removed in order to inspect the outside and inside of the sport tyres. Have the sport tyres checked by a Service Partner of the manufacturer or another qualified Service Partner or a specialist workshop.

Tyre inflation pressure

General

Check the tyre inflation pressure regularly and adjust as necessary, taking the regulations for use on the road or a racing track into account.

Tyre inflation pressure information

The tyre inflation pressure values for the tyre sizes categorised by the vehicle manufacturer as suitable for the respective vehicle type can be found on the door pillar of the driver door.

Mobility System

Principle

With the Mobility System, minor tyre damage can be quickly sealed, to allow you to drive on. For this purpose, liquid sealant is pumped into the tyres which encloses the damage from the inside when it hardens.

General

- ▷ Please observe the notes on the application of the Mobility System which are on the compressor and the sealant container.
- ▷ Applying the Mobility System can be ineffective for tyre damage larger than approximately 4 mm.
- ▷ Contact a Service Partner of the manufacturer or another qualified Service Partner or a specialist workshop if you are unable to put the tyre back in operation.
- ▷ If possible, foreign matter that has penetrated the tyre should remain inside the tyre. Only remove foreign objects if they are visibly protruding from the tyre.
- ▷ Remove the speed limit sticker from the sealant container and attach to the steering wheel.
- ▷ Using sealants can damage the TPM wheel electronics. In this case, have the TPM wheel electronics replaced at the next opportunity.
- ▷ The compressor can be used to check the tyre inflation pressure.

Storage

The Mobility System is located under the boot floor.

Sealant container



- ▷ Sealant container, arrow 1.
- ▷ Filler hose, arrow 2.

Note the use-by date on the sealant container.

Compressor

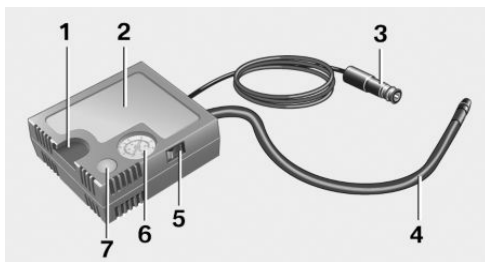

- 1 Sealant container holder
- 2 Compressor
- 3 Plug/cable for socket
- 4 Connecting hose
- 5 On/Off button
- 6 Tyre inflation pressure indicator
- 7 Reduce tyre inflation pressure button

Safety measures

- ▷ Park the vehicle on a solid surface and as far away from moving traffic as possible.
- ▷ Switch on the hazard warning lights.
- ▷ Protect the vehicle against rolling, by applying the parking brake.
- ▷ Engage the steering wheel lock with the wheels in the straight-ahead position.

- Have all vehicle occupants get out of the vehicle and guide them out of the danger area, for example behind the crash barrier.
- Set up the warning triangle an appropriate distance away.

Filling with sealing compound

Safety notes



DANGER

A blocked exhaust pipe or inadequate ventilation can allow harmful exhaust fumes to penetrate the vehicle. The exhaust fumes contain pollutants which are colourless and odourless. In enclosed spaces, the exhaust fumes can also build up outside the vehicle. There is a danger of fatal injury. Keep the exhaust pipe clear and ensure sufficient ventilation. ◀



NOTE

The compressor can overheat if operated for too long. There is a danger of damage to property. Do not let the compressor run for longer than 10 minutes. ◀

Filling

1. Shake the sealant container.



2. Remove the connecting hose entirely from the compressor housing. Do not kink the hose.

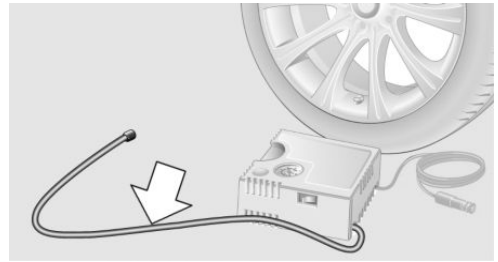

3. Bolt the connecting hose onto the connector of the sealant container.

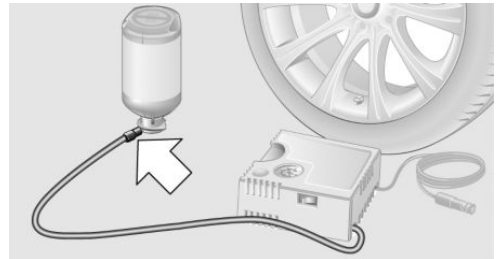

4. Insert the upright sealant container into the compressor housing.

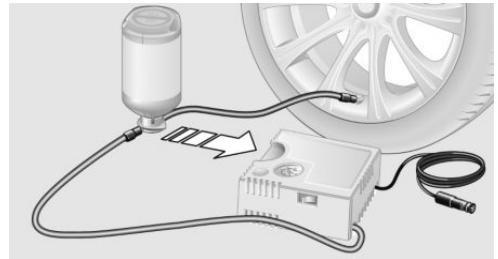

5. Remove the valve cap from the tyre valve and screw the filler hose of the sealant

container onto the tyre valve of the faulty wheel.

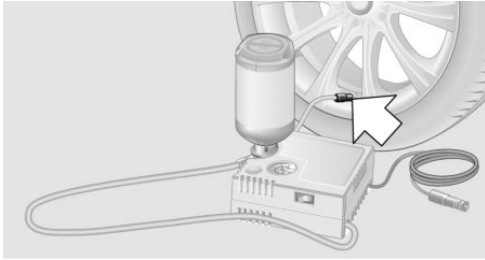

6. Insert the plug into the socket in the vehicle interior while the compressor is switched off.

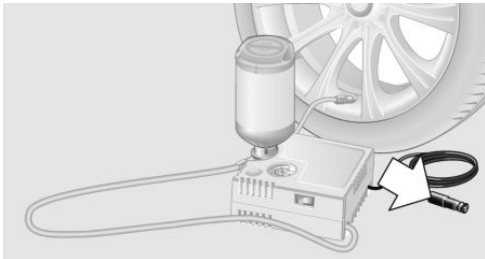

7. Switch on the compressor with the ignition switched on or the engine running.

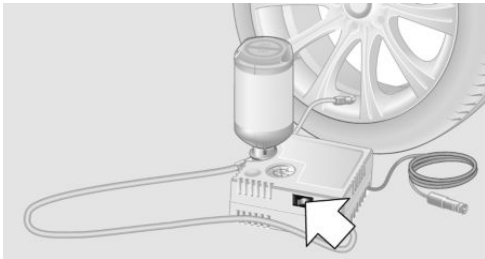

Let the compressor run for approximately 10 minutes to fill the sealing compound and achieve a tyre inflation pressure of approximately 2.5 bar.

The tyre inflation pressure may rise to approximately 5 bar during the filling process of the sealing compound. Do not switch off the compressor during this step.

If it does not reach a tyre inflation pressure of 2 bar:

1. Switch off compressor.
2. Unplug the connector from the socket in the vehicle interior.
3. Unscrew the filler hose from the tyre valve.
4. Drive forwards and backwards by 10 m, approximately 400 inches, to distribute the sealant in the tyre.
5. Re-inflate the tyre with the compressor.

Contact a Service Partner of the manufacturer or another qualified Service Partner or a specialist workshop if the device does not reach a tyre inflation pressure of 2 bar.

Storing Mobility system

1. Unscrew the filler hose of the sealant container from the tyre valve.
2. Unplug the compressor connector from the socket in the vehicle interior.
3. Remove the connecting hose of the compressor from the sealant container.
4. Take the filler hose of the sealant container that was previously connected to the tyre valve and connect it to the free connection on the sealant container.

This can prevent sealant residues escaping from the sealant container.

5. Pack and store the sealant container to avoid soiling the boot.
6. Stow the Mobility System in the boot again.

Spreading sealant compound

Immediately drive for approximately 10 km/5 miles to evenly distribute the sealing compound in the tyre.

Do not exceed the permissible maximum speed of 80 km/h/50 mph.

If possible, do not drive slower than 20 km/h/12 mph.

Correcting the tyre inflation pressure

1. Stop in a suitable area.
2. Screw the connecting hose of the compressor directly onto the tyre valve.
3. Insert the plug into the socket in the vehicle interior.
4. Correct tyre inflation pressure to 2.5 bar.
 - ▶ To increase the tyre inflation pressure: switch on the compressor with the engine running or the ignition switched on.
 - ▶ To reduce tyre inflation pressure: press the button on the compressor.

Resuming with journey

Do not exceed maximum permitted speed of 80 km/h, approximately 50 mph.

Reinitialise the runflat indicator RPA.

Reset the Tyre Pressure Monitor TPM.

Have the faulty tyre and the sealant container of the Mobility System replaced at the next opportunity.

Snow chains

Fine-link snow chains

The manufacturer of your vehicle recommends using fine-link snow chains. Certain fine-link snow chains have been tested, found safe for use in traffic, and categorised as suitable by the manufacturer of the vehicle.

Information regarding suitable snow chains is available from a Service Partner of the manufacturer or another qualified Service Partner or a specialist workshop.

Using

Snow chains may only be used in pairs on the rear wheels with tyres of the following sizes:

- ▶ 255/40 R 18.
- ▶ 255/35 R 19.

Observe the snow chain manufacturer's instructions.

Do not initialise the runflat indicator RPA with snow chains fitted, as it may give incorrect readings.

Do not reset the Tyre Pressure Monitor TPM with snow chains fitted, as it may give incorrect readings.

When driving with snow chains, activate M Dynamic Mode briefly if necessary.

Maximum speed with snow chains

When snow chains are fitted, do not exceed 50 km/h, 30 mph.

Wheel change

General

When using a flat tyre kit, it is not always necessary to change a wheel immediately if tyre inflation pressure is lost due to a flat tyre.

If required, the tools for changing wheels are available as optional accessories from a Service Partner of the manufacturer, another qualified Service Partner or a specialist workshop.

Safety notes



DANGER

The jack is only intended for raising the vehicle briefly during a wheel change. Even if the safety measures are complied with, there is a risk of the raised vehicle falling over due to the jack slipping. There is a danger of injury or even death. If the vehicle is raised with the jack, do not lie underneath the vehicle and do not start the engine. ◀



WARNING

The jack, issued by the vehicle manufacturer, is provided in order to perform a wheel change in the event of a breakdown. The jack is not designed for frequent use; for example, changing from summer to winter tyres. Using

the jack frequently may cause it to become jammed or damaged. There is a danger of injury and damage to property. Only use the jack to change an emergency wheel or a spare wheel in the event of a flat tyre. ◀

WARNING

On soft, uneven or slippery ground, for example, snow, ice, tiles or similar, the jack may slip. There is a danger of injury. Perform the wheel change on a level, firm and non-slip surface if at all possible. ◀

WARNING

The jack is only optimised for raising the vehicle and for use with the jacking points on the vehicle. There is a danger of injury. Do not lift another vehicle or other items with the jack. ◀

WARNING

If the jack has not been guided into the jacking point provided, the vehicle might be damaged when the jack is extended, or the jack could slip. There is a danger of injury or damage to property. When extending, make sure that the jack is guided into the jacking point adjacent to the wheelhouse. ◀

WARNING

A vehicle raised with a jack can fall from the jack if lateral forces are applied. There is a danger of injury and damage to property. If the vehicle is raised, do not apply any lateral forces to the vehicle or pull the vehicle with sudden movements. Have any wheel that is jammed removed by a Service Partner of the manufacturer or another qualified Service Partner or a specialist workshop. ◀

Vehicle jack: Australian/New Zealand standard AS/NZS 2693

2007 – "Vehicle jacks" contains the following warning note which BMW hereby adopts: "... no person should place any portion of their

body under a vehicle that is supported by a jack"

The jack supplied with your vehicle should not be used for any purpose other than wheel changing and should never be used in conjunction with a vehicle support stand. Raising the vehicle for the purpose of inspection should only be performed in a controlled workshop environment on a hoist by trained personnel.

The following warning instructions from standard AS/NZS 2693:2007 are repeated here: the jack should be used on level firm ground wherever possible. It is recommended that the wheels of the vehicle be chocked, and that no person should remain in a vehicle that is being jacked.

The jack of your BMW is maintenance-free.

Please observe the information marked on the jack. ◀

Protecting the vehicle against rolling

General

The vehicle manufacturer recommends that the vehicle should additionally be protected against rolling away during a wheel change.

On a level surface



Place chocks or other suitable objects, such as a stone, in front of and behind the wheel directly opposite to the one being changed.

On a slight downhill slope

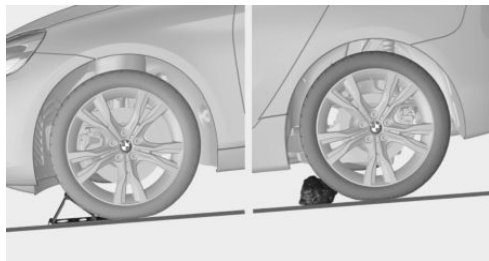

If it is necessary to change a wheel on a slight downhill slope, place chocks and other suitable objects, for example stones, under the wheels of the front and rear axles in the opposite direction to the direction of roll.

Thiefproof wheel studs

Principle

The wheel locking bolts have a special coding. The bolts can only be released with the adapter that matches the coding.

Overview

The adapter of the thiefproof wheel studs can be found in the on-board tool kit or in an oddments tray in the on-board tool kit.

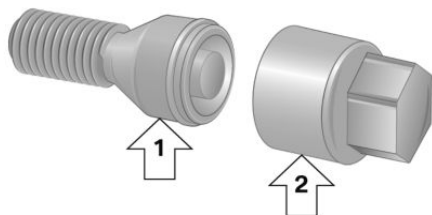

- ▷ Wheel stud, arrow 1.
- ▷ Adapter, arrow 2.

Unscrewing

1. Place the adapter on the wheel stud.
2. Unscrew the wheel stud.

3. After unscrewing the wheel stud, remove the adapter again.

Screwing on

1. Place the adapter on the wheel stud. If necessary, turn the adapter until it fits on the wheel stud.
2. Screw on the wheel stud. The tightening torque is 140 Nm.
3. After screwing on the wheel stud, remove the adapter again and stow it.

Preparing the vehicle

- ▷ Park the vehicle on firm and non-slip ground at a safe distance from traffic.
- ▷ Switch on the hazard warning lights.
- ▷ Apply the parking brake.
- ▷ Engage a gear or select selector lever position P.
- ▷ As soon as the traffic permits, have all vehicle occupants get out of the vehicle and guide them out of the danger area, for example behind the crash barrier.
- ▷ Depending on the equipment, take the tools and emergency wheel out of the vehicle.
- ▷ If applicable, set up warning triangle or flashing light at the correct distance.
- ▷ Do not place wooden blocks or similar underneath the jack, otherwise it will not reach its carrying capacity due to the restricted height.
- ▷ Additionally protect the vehicle against rolling away.
- ▷ Undo the wheel studs by half a turn.

Jack mounting points

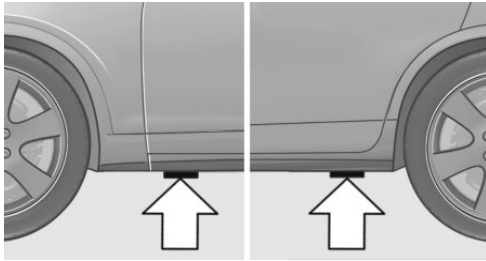

The jacking points are located in the marked positions.

Raising vehicle



WARNING

Your hands or fingers could get trapped when using the jack. There is a danger of injury. Keep your hands in the described position

when using the jack, and do not change this position. ◀

1. Use one hand to secure the jack, arrow 1, and your other hand to grip the jack crank, arrow 2.

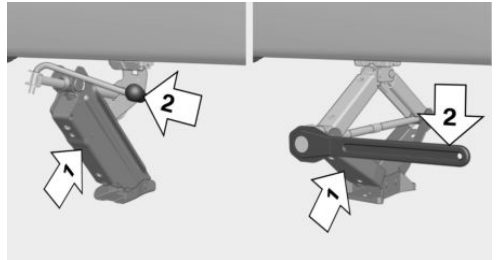

2. Guide the jack into the rectangular recess of the jacking point closest to the wheel to be changed.

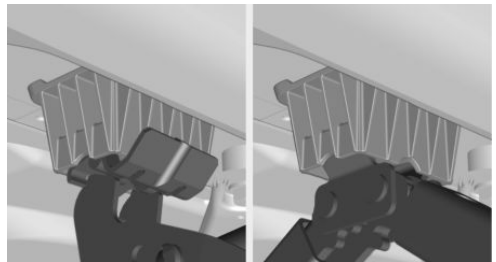

3. Turn the jack crank or lever clockwise to extend the jack.

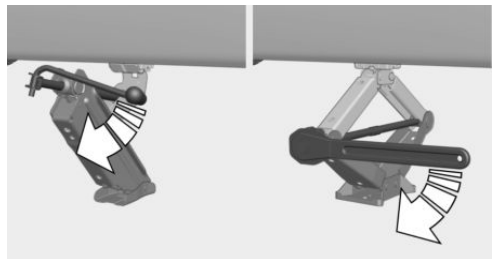

4. Remove your hand from the jack as soon as the jack is under load and continue to turn the jack crank or lever with one hand.

5. Make sure that the base of the jack has been extended vertically.

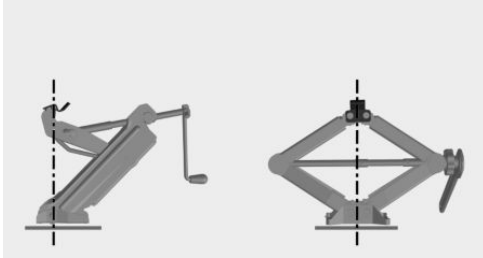

6. Make sure that the base of the jack is extended perpendicular to and at right angles below the jacking point.

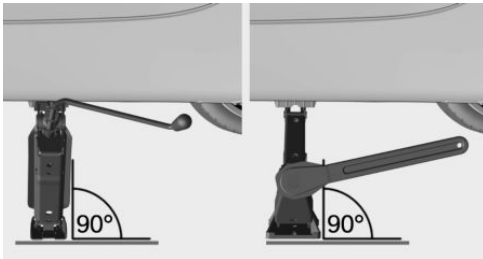

7. Raise by cranking until the jack is supported on the ground with its entire surface and the wheel in question is at most 3 cm, 1.2 inches off the ground.

Fitting a wheel

Only fit one emergency wheel at most, as required.

1. Unscrew the wheel studs.
2. Remove the wheel.
3. Put on the new wheel or emergency wheel and tighten at least two wheel studs crosswise until finger-tight.

If non-original light alloy wheels not from the vehicle manufacturer are fitted, the wheel studs belonging to the wheels may also have to be used.

4. Tighten the remaining wheel studs until finger-tight and then tighten all the wheel studs crosswise.

5. Turn the jack crank anticlockwise to retract the jack and lower the vehicle.
6. Remove the jack and stow it securely.

After changing the wheel

1. Tighten the wheel studs crosswise. The tightening torque is 140 Nm, approximately 101 lb ft.
2. Stow the faulty wheel in the boot, if necessary.

Due to its size, the faulty wheel cannot be accommodated under the boot floor.

3. Check tyre inflation pressure at the next opportunity and correct as necessary.
4. Reinitialise the runflat indicator RPA. Reset the Tyre Pressure Monitor TPM.
5. Check the tight fit of the wheel studs using a calibrated torque wrench.
6. Drive to the nearest Service Partner of the manufacturer or another qualified Service Partner or a specialist workshop to have the damaged tyre replaced.

Engine compartment

Vehicle equipment

This chapter describes all standard, national and special equipment available for the model series. Therefore equipment which is not installed in your vehicle, for example on account

of the selected optional equipment or the country specification, may also be described here. This also applies to safety-relevant functions and systems. Comply with the relevant laws and regulations when using the corresponding functions and systems.

Engine compartment quick reference guide

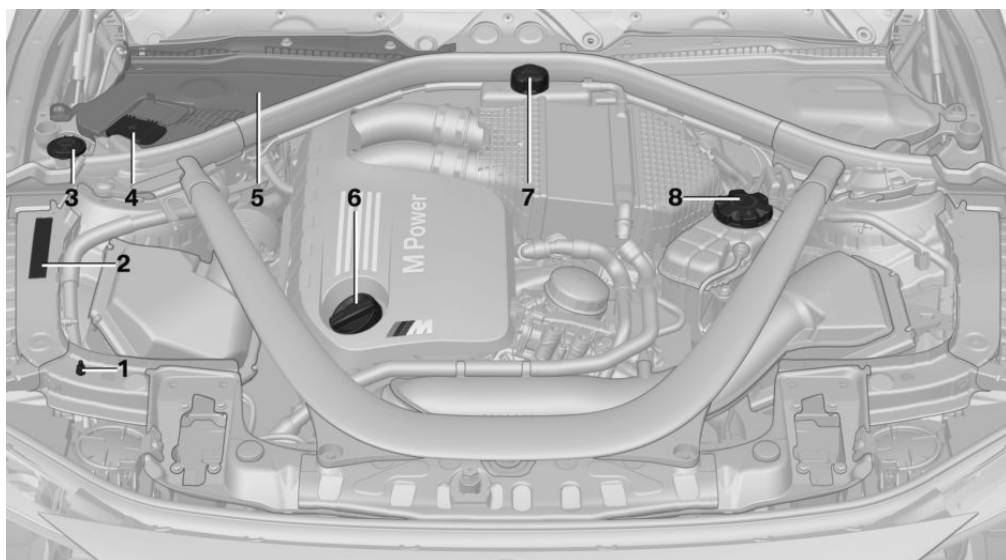

- | | |
|--|---------------------------------------|
| 1 Starting assistance, negative battery terminal | 5 Engine compartment fuse box |
| 2 Vehicle identification number | 6 Oil filler neck |
| 3 Filler neck for washing fluid | 7 Coolant tank for charge air cooling |
| 4 Starting assistance, positive battery terminal | 8 Coolant tank for engine cooling |

Bonnet

Safety notes

⚠ WARNING
Incorrectly performed work in the engine compartment can damage components and lead to a safety risk. There is a danger of accident or damage to property. Have work in the engine compartment undertaken by a Service Partner of the manufacturer or another qualified Service Partner or a specialist workshop. ◀

⚠ WARNING
The engine compartment contains moving components. Certain components in the engine compartment can also move when the vehicle is switched off, for example the radiator fan. There is a danger of injury. Do not reach into the area of moving parts. Keep articles of clothing and hair away from moving parts. ◀

⚠ WARNING
The bonnet has projecting parts on the inside, for example locking hooks. There is a danger of injury. When the bonnet is open, watch out for projecting parts and keep these areas clear. ◀

⚠ WARNING
If the bonnet is not correctly locked, it can come open during the journey and impair visibility. There is a danger of accidents. Stop immediately and close the bonnet correctly. ◀

⚠ WARNING
Parts of the body can become trapped when opening and closing the bonnet. There is a danger of injury. When opening and closing, make sure that the area of movement of the bonnet is free. ◀

⚠ NOTE
When wipers are folded away from the windscreen, they can be trapped when the bonnet is opened. There is a danger of dam-

age to property. Before opening the bonnet, make sure that the wipers with wiper blades fitted are in contact with the windscreen. ◀

⚠ NOTE
When closing, the bonnet must lock into place on both sides. Applying additional pressure can damage the bonnet. There is a danger of damage to property. Open the bonnet again and close it firmly. Avoid applying additional pressure. ◀

Open the bonnet

1. Pull the lever, arrow 1.
The bonnet is released.

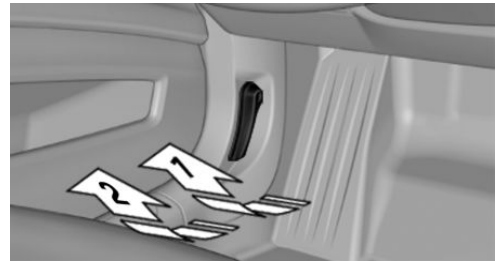

2. After releasing the lever, pull the lever again, arrow 2.
The bonnet is opened.

Indicator and warning lamps

With the bonnet unlocked, a Check Control message is shown.

Closing bonnet

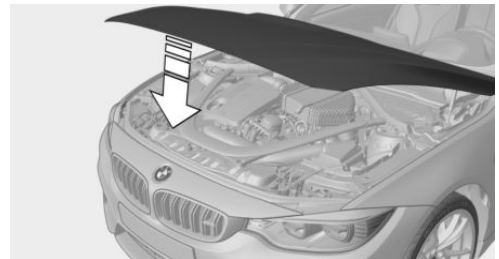

Close the bonnet firmly with both hands.

The bonnet must engage into place on both sides.

Engine oil

Vehicle equipment

This chapter describes all standard, national and special equipment available for the model series. Therefore equipment which is not installed in your vehicle, for example on account of the selected optional equipment or the country specification, may also be described here. This also applies to safety-relevant functions and systems. Comply with the relevant laws and regulations when using the corresponding functions and systems.

General

The engine oil consumption depends on the driving style and operating conditions.

Therefore check the engine oil level regularly each time you fill up with fuel by taking a detailed measurement.

Engine oil consumption can be increased, for example, in the following situations:

- ▷ Dynamic driving style.
- ▷ Running in the engine.
- ▷ Engine idling.
- ▷ Use of engine oil grades categorised as unsuitable.

Different Check Control messages are shown on the Control Display, depending on the engine oil level.

Safety notes



NOTE

Too little engine oil causes engine damage. There is a danger of damage to property. Immediately replenish engine oil. ◀



NOTE

Too much engine oil can damage the engine or the catalytic converter. There is a danger of damage to property. Do not top up with too much engine oil. If there is too much engine oil, have the engine oil level corrected by a Service Partner of the manufacturer or another qualified Service Partner or a specialist workshop. ◀

Electronic oil measurement

General

Electronic oil measurement has two measurement principles:

- ▷ Monitoring.
- ▷ Detailed measurement.

When frequently making short trips or using a dynamic driving style, for example taking corners at high speed, regularly perform a detailed measurement.

Monitoring

Principle

The engine oil level is electronically monitored during the journey and can be shown on the Control Display.

If the engine oil level is outside its permissible operating range, a Check Control message is shown.

Operating requirements

A current measurement is available after approximately 30 minutes of normal driving.

Displaying the engine oil level

Via iDrive:

1. "My Vehicle"
2. "Vehicle status"
3.  "Engine oil level"

The engine oil level is displayed.

System limits

When frequently making short trips or using a dynamic driving style, it may not be possible to calculate a measurement. In this case, the measurement for the last, sufficiently long journey is displayed.

Detailed measurement

Principle

The engine oil level is checked when the vehicle is stationary and is shown on a scale.

If the engine oil level is outside its permissible operating range, a Check Control message is shown.

General

During the measurement, the idle speed is slightly raised.

Operating requirements

- ▷ Vehicle is standing horizontally.
- ▷ Manual gearbox: gear lever in neutral position, clutch and accelerator pedal not pressed.
- ▷ M double clutch transmission: selector lever in selector lever position N and accelerator pedal not pressed.
- ▷ Engine is running and is at operating temperature.

Carrying out a detailed measurement

Via iDrive:

1. "My Vehicle"
2. "Vehicle status"
3.  "Engine oil level"
4. "Measure engine oil level"
5. "Start measurement"

The engine oil level is checked and shown on a scale.

Adding engine oil

General

Do not top up engine oil unless a message is displayed in the instrument cluster. The top-up amount is specified in the message on the instrument cluster.

Only replenish with suitable types of engine oil, see page 225.

Safely park the vehicle and switch off the ignition before replenishing the engine oil.

Ensure not to top up with too much engine oil.

Spilled engine oil can damage carbon parts.

Wipe up spilled engine oil with a lint-free cloth.

Safety notes



WARNING

Service products, for example oils, greases, coolants and fuels, can contain substances that are harmful to health. There is a danger of injury or even death. Comply with the notes on the containers. Do not allow service products to come into contact with clothing, skin or eyes. Do not pour service products into other bottles. Keep service products out of the reach of children. ◀



NOTE

Too little engine oil causes engine damage. There is a danger of damage to property. Immediately replenish engine oil. ◀

**NOTE**

Too much engine oil can damage the engine or the catalytic converter. There is a danger of damage to property. Do not top up with too much engine oil. If there is too much engine oil, have the engine oil level corrected by a Service Partner of the manufacturer or another qualified Service Partner or a specialist workshop. ◀

Overview

The oil filler neck is in the engine compartment, see page 220.

Adding engine oil

1. Open the bonnet, see page 221.
2. Turn the cap anticlockwise.

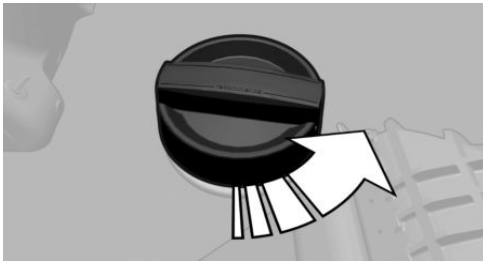

3. Add engine oil.

Engine oil grades for topping up**General**

The engine oil quality is decisive for the lifetime of the engine.

Several engine oil grades are not available in all countries.

Safety notes**NOTE**

Oil additives can damage the engine. There is a danger of damage to property. Do not use oil additives. ◀

**NOTE**

Incorrect engine oil can lead to engine malfunctions and damage. There is a danger of damage to property. When selecting the engine oil, make sure that the oil specification of the engine oil is correct. ◀

Suitable engine oil grades

Engine oils with the following oil specifications can be used for topping up:

Oil specification

BMW Longlife-01.

BMW Longlife-01 FE.

BMW Longlife-04.

BMW Longlife-12 FE.

Information on suitable oil specifications and viscosities of engine oils can be obtained from a Service Partner of the manufacturer or another qualified Service Partner or a specialist workshop.

Alternative engine oil types

If suitable engine oils are not available, up to 1 litre, approximately 2 pints, of an engine oil with the following oil specification can be used for topping up:

Oil specification

ACEA A3/B4.

Viscosity classes

When selecting an engine oil, ensure that the engine oil has viscosity class SAE 0W-30. Alternatively, engine oils with viscosity classes of

SAE 5W-30, SAE 0W-40 or SAE 5W-40 may also be used.

Information on suitable oil specifications and viscosities of engine oils can be obtained from a Service Partner of the manufacturer or another qualified Service Partner or a specialist workshop.

Oil change



NOTE

Engine oil not replaced in time can lead to increased engine wear and thus engine damage. There is a danger of damage to property. Do not exceed the service date indicated in the vehicle. ◀

The manufacturer of the vehicle recommends having the engine oil changed by a Service Partner of the manufacturer or another qualified Service Partner or a specialist workshop.

BMW recommends
Original BMW Engine Oil.

Coolant

Vehicle equipment

This chapter describes all standard, national and special equipment available for the model series. Therefore equipment which is not installed in your vehicle, for example on account of the selected optional equipment or the country specification, may also be described here. This also applies to safety-relevant functions and systems. Comply with the relevant laws and regulations when using the corresponding functions and systems.

General

The vehicle has two coolant tanks located in the engine compartment.

To guarantee operational safety of the vehicle, always check the coolant levels of both coolant tanks.

Not all commercially available additives are suitable for the vehicle. Information regarding suitable additives is available from a Service Partner of the manufacturer or another qualified Service Partner or a specialist workshop.

Safety notes



WARNING

If the cooling system is opened when the engine is hot, coolant can escape and cause scalds. There is a danger of injury. Only open the cooling system when the engine has cooled down. ◀



WARNING

Additives are harmful to health and incorrect additives can damage the engine. There is a danger of injury and damage to property. Do not allow additives to come into contact with

clothing, skin or eyes, and do not swallow them. Only use suitable additives. ◀

Coolant level

Checking

1. Allow the engine to cool down.
2. Turn cap on coolant tank slightly anticlockwise, then allow the pressure to escape.

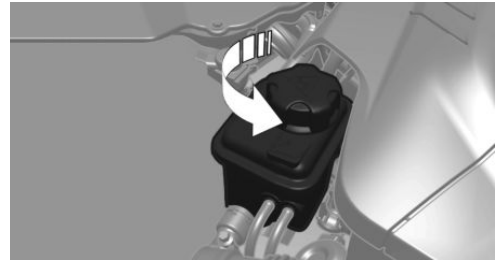

3. Open cap on coolant tank.
4. The coolant level is correct if it is between the Min. and Max. marks in the filler neck.



Topping up

1. Allow the engine to cool down.
2. Turn the cap on the coolant tank slightly anticlockwise until it starts to open, then

allow the pressure to escape before opening it fully.

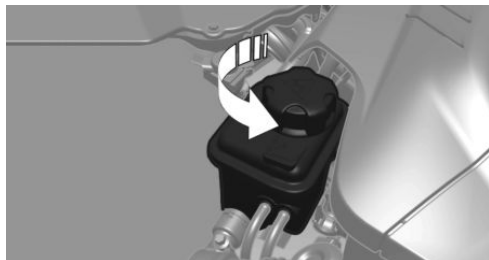

3. If necessary, slowly top up to the correct level; do not overfill.
4. Tighten cap.
5. Have the cause of coolant loss rectified as soon as possible.

Disposal



When disposing of coolant and coolant additives, comply with the relevant environmental protection regulations.

Maintenance

Vehicle equipment

This chapter describes all standard, national and special equipment available for the model series. Therefore equipment which is not installed in your vehicle, for example on account of the selected optional equipment or the country specification, may also be described here. This also applies to safety-relevant functions and systems. Comply with the relevant laws and regulations when using the corresponding functions and systems.

BMW Maintenance System

The Maintenance System indicates what maintenance measures are required, thus providing support in maintaining the road and operational safety of the vehicle.

Scopes and intervals may vary depending on the national specifications. Replacement work, spare parts, operating materials and wear materials are calculated separately. Additional information is available from a Service Partner of the manufacturer or another qualified Service Partner or a specialist workshop.

Condition Based Service, CBS

Principle

Sensors and special algorithms monitor the conditions in which the vehicle is used. CBS uses this information to determine the maintenance requirement.

The system thus enables the scope of the maintenance work to be adapted to the individual usage profile.

General

Information on service requirements, see page 109, can be displayed on the Control Display.

Service data in the remote control

Information about the maintenance requirement is continuously stored in the remote control. The Service Partner can read out this data and suggest a maintenance scope for your vehicle.

Therefore hand the service advisor the remote control with which the vehicle was driven most recently.

Periods out of use

Periods when the vehicle is out of use with its battery disconnected are not taken into account.

In such cases, time-dependent maintenance procedures, such as checking brake fluid and, if applicable, changing the engine oil and the microfilter/activated charcoal filter, should be updated by a Service Partner of the manufacturer or another qualified Service Partner or a specialist workshop.

Service history

Maintenance and repairs

Have maintenance and repairs carried out by a Service Partner of the manufacturer or another qualified Service Partner or a specialist workshop.

Entries

The maintenance work carried out is entered in the maintenance records and the vehicle data. As with a service booklet, the entries provide evidence of regular maintenance.

If an entry is made in the electronic service history of the vehicle, service-relevant data is saved both in the vehicle and on the central IT systems of BMW AG, Munich.

The data entered in the electronic service history can also be viewed by the new vehicle owner after a change of vehicle owner. A Service Partner of the manufacturer or another qualified Service Partner or a specialist workshop can view the data entered in the electronic service history.

Objection

The vehicle owner can contact a Service Partner of the manufacturer or another qualified Service Partner or a specialist workshop to object to any entries being made in the electronic service history, and to any associated data relating to his/her time as the vehicle owner being stored in the vehicle or transferred to the vehicle manufacturer. In that case, no entry is made in the electronic service history of the vehicle.

Displays

The entered maintenance activities can be displayed using the service history, see page 110, on the Control Display.

For Australia/New Zealand: maintenance

No maintenance work other than normal maintenance is required to keep the emission levels of your vehicle within the design limits.

Socket for on-board diagnosis, OBD

Safety note



NOTE

Incorrect use of the socket for on-board diagnosis, OBD can result in malfunctions in the vehicle. There is a danger of damage to property. Only have service and maintenance work involving the socket for on-board diagnosis, OBD carried out by a Service Partner of the manufacturer or another qualified Service Partner or a specialist workshop, or other authorised persons. Only connect devices that have been tested and found to be safe for use with the socket for on-board diagnosis, OBD. ◀

Position

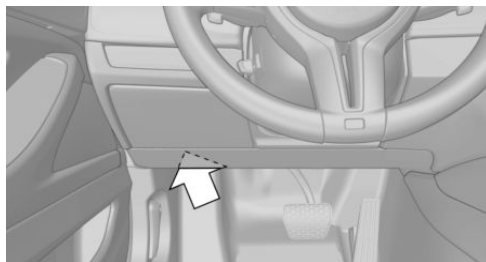

The OBD socket for checking components which are relevant for exhaust gas composition is located on the driver's side.

Emissions



- ▶ The warning lamp flashes:
There is an engine malfunction which could damage the catalytic converter. Have the vehicle checked as soon as possible.
- ▶ The warning lamp is illuminated:
Deterioration of exhaust emissions. Have the vehicle checked as soon as possible.

Recycling

The manufacturer of your vehicle recommends handing the vehicle in at a take-back point nominated by the manufacturer at the end of its life cycle. The regulations concerning the returning of end-of-life vehicles may vary from country to country. Additional information is available from a Service Partner of the manufacturer or another qualified Service Partner or a specialist workshop.

Replacing parts

Vehicle equipment

This chapter describes all standard, national and special equipment available for the model series. Therefore equipment which is not installed in your vehicle, for example on account of the selected optional equipment or the country specification, may also be described here. This also applies to safety-relevant functions and systems. Comply with the relevant laws and regulations when using the corresponding functions and systems.

On-board tool kit

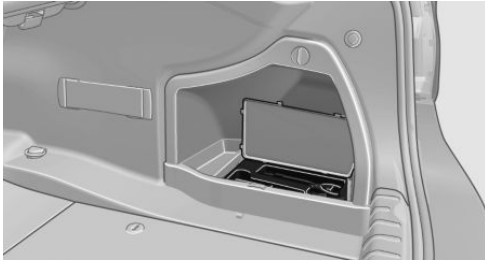

The on-board tool kit is located in a compartment on the right in the boot. Open the cover.

Replacing the wiper blades

Safety note



NOTE

The windscreen can be damaged if the wiper arm drops onto the windscreen without wiper blades fitted. There is a danger of damage to property. Hold the wiper arm firmly when changing the wiper blades and do not fold in the wipers unless wiper blades are fitted. ◀

Replacing the wiper blades

1. To replace the wiper blades, place the wipers in the fold-out position, see page 93.
2. Fold out wiper arm and hold firm.
3. Press together securing spring, arrow 1, and fold out the wiper blade, arrow 2.

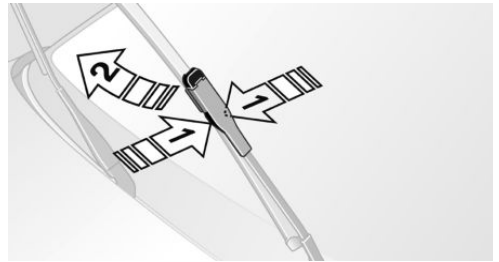

4. Take the wiper blade forwards out of the fitting.
5. Insert new wiper blade in the opposite sequence until it engages.
6. Fold in the wipers.



NOTE

When wipers are folded away from the windscreen, they can be trapped when the bonnet is opened. There is a danger of damage to property. Before opening the bonnet, make sure that the wipers with wiper blades fitted are in contact with the windscreen. ◀

Replacing lights and bulbs

General

Bulbs and lights

Lights and bulbs are an important aspect of driving safety.

The manufacturer of the vehicle recommends having the corresponding work carried out by a Service Partner of the manufacturer or another

qualified Service Partner or a specialist workshop.

Comply with the safety notes, see page 233.

Light-emitting diodes, LEDs

Some equipment versions have light-emitting diodes behind a cover as a light source. These light-emitting diodes are similar to conventional lasers and are classified by legislation as Class 1 light-emitting diodes.

Comply with the safety notes, see page 233.

Safety notes

Bulbs and lights



WARNING

Bulbs can become hot during operation. Contact with the bulbs can lead to burns. There is a danger of injury. Only replace bulbs when they have cooled down. ◀



WARNING

Short circuits can occur when working on lighting systems that are switched on. There is a danger of injury or damage to property. Switch the respective lights off when working on the lighting system. Where applicable, observe the enclosed instructions from the bulb manufacturer. ◀



NOTE

Dirty bulbs have a reduced lifetime. There is a danger of damage to property. Do not touch the glass of new bulbs with your bare hands. Use a clean tissue or similar, or hold the bulb by its base. ◀

Light-emitting diodes, LEDs



WARNING

Excessively intense brightness can irritate or harm the retina of the eye. There is a danger of injury. Do not look directly into the headlights or other light sources. Do not remove covers from LEDs. ◀

Headlight glass

During cool or humid weather, the exterior lights can mist over on the inside. When driving with the lights switched on, the condensation disappears after a short time. There is no need to replace the headlight glass.

If moisture increasingly forms, for example if there are water droplets in the lamp, despite the headlights being switched on, have the headlights checked.

Front lights, replacing the lamps

LED headlights

Light-emitting diodes, LEDs

All front lights and side turn indicators are in LED technology.

Contact a Service Partner of the manufacturer or another qualified Service Partner or a specialist workshop in the case of a defect.

Turn indicator in exterior mirror

The turn indicators in the exterior mirrors use LED technology. Contact a Service Partner of the manufacturer or another qualified Service Partner or a specialist workshop in the case of a defect.

Rear lights, replacing the bulbs

Rear lights, number plate lights and centre brake light

The lights are designed in LED or OLED technology. Contact a Service Partner of the manufacturer or another qualified Service Partner or a specialist workshop in the case of a defect.

Car battery

Maintenance

The battery is maintenance-free.

More information regarding the battery can be obtained from a Service Partner of the manufacturer or another qualified Service Partner or a specialist workshop.

Replacing the vehicle battery

General

The manufacturer of your vehicle recommends having a Service Partner of the manufacturer or another qualified Service Partner or a specialist workshop register the vehicle battery to the vehicle after the battery has been replaced. Once the battery has been registered again, all comfort functions will be available without restriction and any Check Control messages relating to the comfort functions will no longer be displayed.

Safety note



NOTE

Vehicle batteries that are classified as unsuitable may damage systems or result in functions no longer being carried out. There is a danger of damage to property. Only use vehicle batteries that have been classified as suitable by the vehicle manufacturer. ◀

Charging the battery

General

Ensure the battery is sufficiently charged to guarantee the entire lifetime of the battery.

The battery may need to be charged in the following cases:

- ▷ When making frequent short journeys.
- ▷ If the vehicle is not used for periods of longer than one month.

Safety notes



NOTE

Incompatible external battery chargers can damage the vehicle. There is a danger of damage to property. Use battery chargers that have been categorised as suitable for the respective vehicle type by the vehicle manufacturer. Observe the maximum charge voltage. ◀

Maximum charge voltage: 14.4 Volt.



NOTE

Battery chargers for the vehicle battery can operate with high voltages and high currents, which can overload or damage the 12-volt on-board network. There is a danger of damage to property. Only connect battery chargers for the vehicle battery to the jump-starting connections in the engine compartment. ◀

Jump-starting connections

Only charge the battery via the jump-starting connections, see page 240, in the engine compartment and with the engine switched off.

Battery charger

Battery chargers developed especially for the vehicle and suitable for the on-board network can be obtained from a Service Partner of the manufacturer or another qualified Service Partner or a specialist workshop.

Power failure

Following an electrical power outage, some equipment will have to be reinitialised or individual settings will need to be updated, for example:

- ▷ Seat and mirror memory: re-save positions.
- ▷ Time: update.
- ▷ Date: update.
- ▷ Glass Roof and sun blind: initialise system.

Disposing of the old battery



Dispose of old batteries at a Service Partner of the manufacturer or another qualified Service Partner or a specialist workshop or hand them into an authorised collecting point.

Fuses

Safety note



WARNING

Incorrect or repaired fuses can overload electrical cables and components. There is a risk of fire. Do not repair blown fuses or renew them with fuses of a different colour or amp rating. ◀

Changing a fuse

The fuses are located at two different positions in the vehicle.

Plastic tweezers and details of the fuse assignment can be found with the fuses in the boot.

In the engine compartment

General

On right-hand drive vehicles, the fuses are located on the opposite side of the engine compartment.

Removing the cover

1. Undo the three screws of the cover, arrow 1, with the on-board tool.

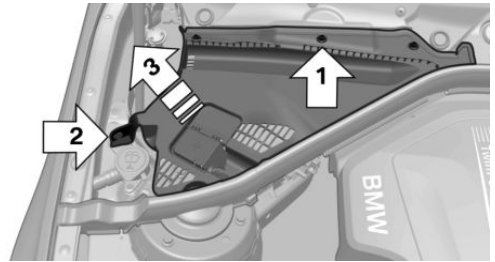

2. Pull fastening upwards, arrow 2.
3. Remove cover from the side, arrow 3.
4. Press on the four fastenings and remove the lid.

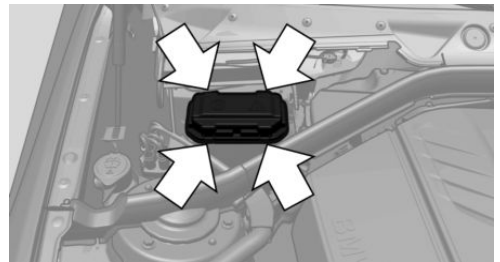

Attaching covers

1. When attaching the lid, ensure that all four fastenings are engaged.
2. Attach cover under the rubber lip and then thread between the webs.

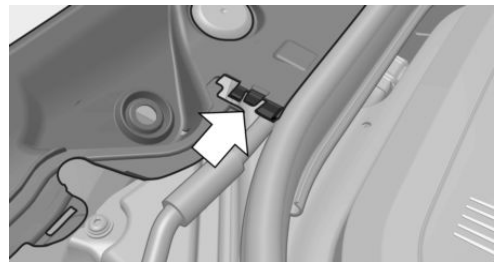

3. Press fastening downwards and tighten the three screws.

Inside the boot

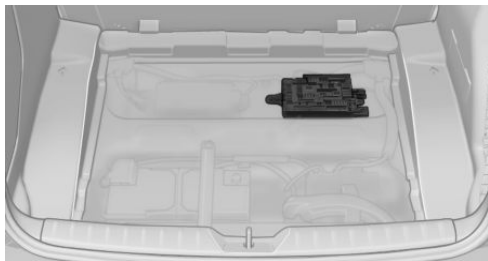

Fold up boot floor.

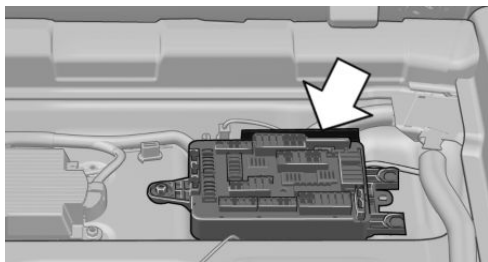

Details of the fuse assignment are on a separate leaflet.

Breakdown Assist

Vehicle equipment

This chapter describes all standard, national and special equipment available for the model series. Therefore equipment which is not installed in your vehicle, for example on account of the selected optional equipment or the country specification, may also be described here. This also applies to safety-relevant functions and systems. Comply with the relevant laws and regulations when using the corresponding functions and systems.

Hazard warning lights

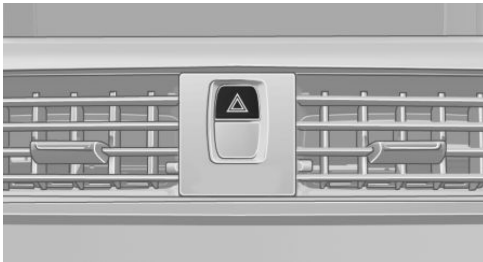

The button is located in the centre console.

Intelligent emergency call

Principle

The system can be used for sending an emergency call in emergency situations.

General

Press the SOS button in an emergency only. Even if no emergency call through BMW is possible, in some cases an emergency call may still be established to a public emergency call number. This depends on factors such as the specific mobile telephone network and the national regulations.

For technical reasons, it might not be possible to make an emergency call in highly adverse conditions.

Overview



SOS button in roof lining

Operating requirements

- ▷ SIM card integrated into the vehicle is activated.
- ▷ Radio ready state is switched on.
- ▷ Emergency call system is functional.

Automatically activating emergency calls

In certain circumstances, for example deployment of the airbags, an emergency call may be placed automatically immediately after an accident of corresponding severity. An automatic emergency call is not influenced by pressing the SOS button.

Triggering an emergency call manually

1. Briefly press the cover flap to open it.
 2. Press the SOS button until the LED on the button is illuminated green.
- ▷ LED is illuminated green when the emergency call is activated.

If a cancellation request is displayed on the Control Display, the emergency call can be cancelled.

If the situation permits, wait in the vehicle until voice contact has been established.

- ▷ LED flashes green when the connection to the emergency number has been established.

When an emergency call is sent via BMW, data is sent to the emergency call centre in order to decide what rescue measures are required. The data may include, for example, the current position of the vehicle, if this can be determined. If questions posed by the emergency call centre remain unanswered, rescue measures are automatically initiated.

If you can no longer hear the emergency call centre through the loudspeakers, the hands-free system may be broken. However, the emergency call centre may still be able to hear you speak.

The emergency call centre ends the emergency call.

Mobile Service

General

In many countries, the Mobile Service is available by phone twenty-four hours a day, seven days a week. Support can be obtained there in the event of a breakdown.

Breakdown assistance

Principle

The Mobile Service offered by the BMW Group can be contacted if you require help in the event of a breakdown.

General

In the case of a breakdown, data on the vehicle condition can be transferred to the Mobile

Service. It is possible that malfunctions can be remedied directly.

Contact with the Mobile Service can also be done with a Check Control message, see page 105.

Requirements

- ▷ Activated ConnectedDrive contract, equipment with intelligent emergency call or BMW ConnectedDrive services.
- ▷ Mobile reception.
- ▷ Ignition or standby state is switched on.

Starting breakdown assistance

When equipped with Teleservice, support is provided first through the Teleservice Diagnosis and then by the Teleservice Assistance.

Via iDrive:

1. "ConnectedDrive"
2. "BMW Assistance"
3. "BMW Roadside Assistance"

A voice connection is established.

Teleservice Diagnosis

Teleservice Diagnosis enables the transfer of detailed vehicle data that is necessary for diagnosis of the vehicle via mobile telephony. This data is transferred automatically.

A voice connection to Mobile Service is established.

Starting Teleservice Assistance

The Teleservice Assistance enables a deeper diagnosis of the vehicle by the Mobile Service.

You can launch Teleservice Assistance by requesting it through Mobile Service.

1. Park the vehicle safely.
2. Apply the parking brake.
3. Control Display is switched on.
4. "Teleservice Help"

Certain functions within the vehicle may be restored to a drivable condition.

If this is not possible, further measures will be initiated, for example Mobile Service will be informed.

Warning triangle



The warning triangle is located inside the boot lid.

To remove, release the mounts.

First-aid kit

General

Some items in the kit have a limited shelf life.

Check the use-by dates of the contents regularly and replace any items that have expired in good time.

Storage



The first-aid kit is located on the right in a storage compartment in the boot.

Starting assistance

General

If the vehicle battery is discharged, the engine can be started using two jump leads from another vehicle's battery. Use only jump leads with fully insulated terminal clamps.

Safety notes



DANGER

Touching live components can result in an electric shock. There is a danger of injury or even death. Do not touch any components that could be live. ◀



WARNING

Connecting the jump leads in the wrong sequence can cause sparks. There is a danger of injury. Comply with the correct sequence when connecting up. ◀



NOTE

Contact between the bodies of the two vehicles can result in a short circuit during starting assistance. There is a danger of damage to property. Make sure there is no contact between the bodies. ◀

Preparations

1. Check whether the battery in the other vehicle shows 12 volts. Information about the voltage is provided on the battery.
2. Switch off the engine of the donor vehicle.
3. Switch off any electrical systems in both vehicles.

Jump-starting connections

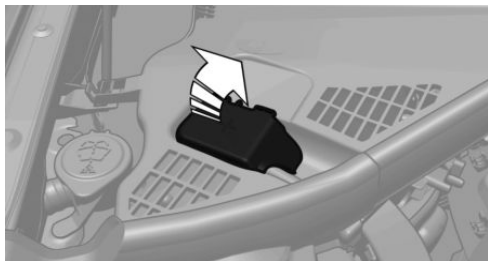

The jump-starting connection in the engine compartment serves as the positive battery terminal.

Open the cover of the jump-starting connection.

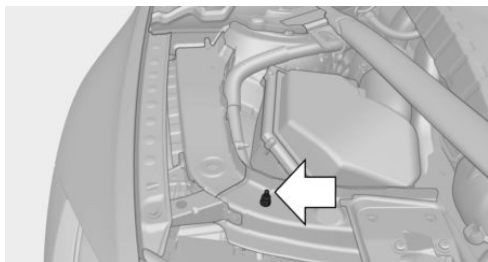

The battery negative terminal is the body earth or a special nut.

Connecting the cables

Do not deviate from the procedure described below, otherwise personal injury could result or both vehicles could be damaged.

1. Open the cover of the BMW jump-starting connection.
2. Connect a terminal clamp on the positive/+ jump lead to the positive terminal of the battery or the corresponding jump-starting connection on the donor vehicle.
3. Connect the other terminal clamp to the battery's positive terminal or to the corresponding jump-starting connection on the vehicle to be started.

4. Connect a terminal clamp on the negative/- jump lead to the negative terminal of the battery or the corresponding engine or body earth connection on the donor vehicle.
5. Connect the second terminal clamp to the negative terminal of the battery or to a corresponding engine or body earth connection on the vehicle to be started.

Starting the engine

Do not use the spray products sold as starting aids.

1. Start the engine of the donor vehicle and allow it to run for a few minutes at a slightly increased idle speed.
2. Start the engine of the vehicle to be started as normal.

If an initial attempt to start the engine fails, wait several minutes until the discharged battery has been recharged to a slightly greater degree.

3. Allow both engines to run for a few minutes.
4. Disconnect the jump leads in the opposite order from that in which they were originally attached.

Check the battery if necessary and have it recharged.

Tow-starting and towing away

Safety note



WARNING

Due to system limitations, there may be malfunctions of individual functions when tow starting/towing with activated Intelligent Safety Systems. There is a danger of accidents. Switch off all Intelligent Safety Systems before tow-starting/towing. ◀

Manual gearbox

Towing or pushing the vehicle

A broken-down vehicle can be towed or pushed.

Roll or push, see page 95, the vehicle.

Observe the following notes:

- ▶ Make sure that the ignition is switched on, otherwise low-beam headlights, rear lights, turn indicators and wipers will not be available.
- ▶ Do not tow the vehicle with the rear axle raised, otherwise the steering can turn.
- ▶ When the engine is not running, there is no power assistance. The steering and brakes will require extra effort to operate.
- ▶ Greater steering wheel movements are necessary.
- ▶ The towing vehicle must not be lighter than the towed vehicle, otherwise it may be unable to keep the towed vehicle reliably under control.
- ▶ Do not exceed a towing speed of 50 km/h, 30 mph.
- ▶ Do not exceed a towing distance of 50 km, 30 miles.

Towing truck

With driven rear axle

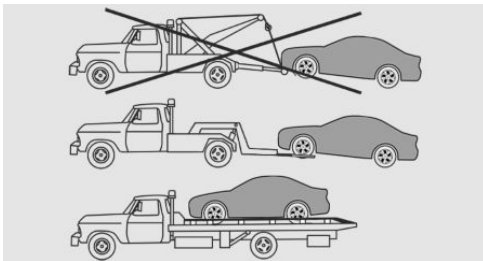

Have the vehicle transported by a towing truck with a hoisting frame, or hoisted onto a loading platform.



NOTE

The vehicle can become damaged when raising and securing it.

There is a danger of damage to property.

- ▶ Raise the vehicle with suitable equipment.
- ▶ Do not raise or secure the vehicle by its towing eye, body parts or suspension parts. ◀

M double clutch transmission: transporting the vehicle

General

Do not attempt to have the vehicle towed.

Safety note



NOTE

If the vehicle is towed with one axle raised, the vehicle can be damaged. There is a danger of damage to property. Only have the vehicle transported on a load platform. ◀

Pushing the vehicle

To remove a broken-down vehicle from a dangerous area, it can be pushed for a short distance.

Roll or push, see page 97, the vehicle.

Towing truck

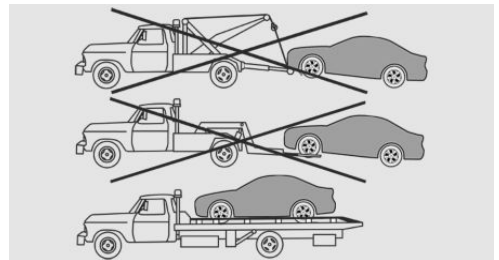

Only have the vehicle transported on a load platform.

**NOTE**

The vehicle can become damaged when raising and securing it.

There is a danger of damage to property.

- ▷ Raise the vehicle with suitable equipment.
- ▷ Do not raise or secure the vehicle by its towing eye, body parts or suspension parts. ◀

Towing other vehicles

General

Switch on the hazard warning lights, depending on local regulations.

If the vehicle's electrical system has failed, the vehicle being towed must be made identifiable to following vehicles, for instance by placing an indicating label or the warning triangle in the rear window.

Safety notes

**WARNING**

If the gross vehicle weight of the towing vehicle is less than that of the vehicle to be towed, the towing eye can be pulled off, or the vehicle may no longer be controllable. There is a danger of accidents! Make sure that the gross vehicle weight of the towing vehicle is more than the weight of the vehicle to be towed. ◀

**NOTE**

If the tow bar or the towing rope is not attached correctly, other vehicle parts can be damaged. There is a danger of damage to property. Attach the tow bar or towing rope to the towing eye correctly. ◀

Tow bar

The towing eyes of both vehicles should be on the same side.

If it is impossible to avoid attaching the tow bar at an angle, note the following:

- ▷ Tow bar clearance may be restricted when cornering.
- ▷ The tow bar will generate lateral forces if it is attached offset.

Towing rope

Ensure that the towing rope is taut when the towing vehicle drives off.

Use nylon ropes or straps, which will enable the vehicle to be towed without jerking.

Towing eye

General

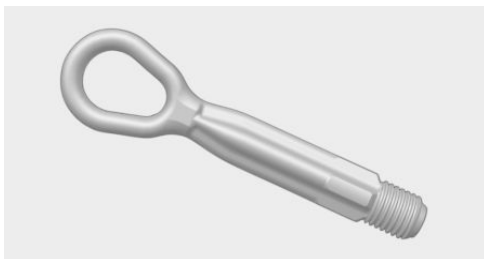

Always have the screw-on towing eye on board the vehicle.

The towing eye can be screwed into the front or rear end of the vehicle.

The towing eye together with the on-board tool kit, see page 232, is located in the boot.

Using the towing eye:

- ▷ Use only the towing eye supplied with the vehicle, and make sure that it is screwed in fully and is tight.
- ▷ Only use the towing eye for towing on normal roads (in other words not off-road).
- ▷ Avoid lateral loads on the towing eye, for example do not raise the vehicle at the towing eye.

Safety note



NOTE

If the towing eye is not used as intended, the vehicle or towing eye may be damaged. There is a danger of damage to property. Observe the notes on using the towing eye. ◀

Thread for towing eye

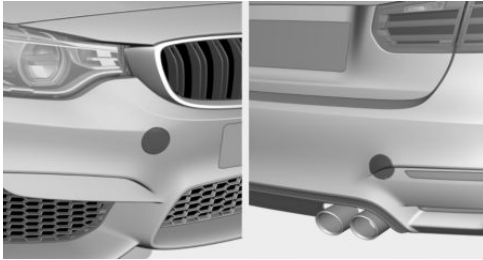

Press the marking on the front cover to press it out.

Use the screwdriver from the on-board tool kit to press out the rear cover at the opening.

Tow-starting

M double clutch transmission

Do not attempt to tow-start or push-start the vehicle.

Due to the M double clutch transmission it is not possible to start the engine by towing.

Have the cause if the starting difficulties rectified by a Service Partner of the manufacturer or another qualified Service Partner or a specialist workshop.

Manual gearbox

If possible, do not tow-start the vehicle but start the engine using starting assistance, see

page 239. Only tow-start when the engine is cold if your vehicle has a catalytic converter.

1. Switching on the hazard warning lights, please observe country-specific regulations.
2. Switch on the ignition, see page 85.
3. Engage 3rd gear.
4. Tow-start with the clutch pressed and release the clutch slowly. Press the clutch again immediately after the engine starts.
5. Stop in a suitable location, remove the tow bar or towing rope and switch off the hazard warning lights.
6. Have the vehicle checked by a Service Partner of the manufacturer or another qualified Service Partner or a specialist workshop.

General care

Vehicle equipment

This chapter describes all standard, national and special equipment available for the model series. Therefore equipment which is not installed in your vehicle, for example on account of the selected optional equipment or the country specification, may also be described here. This also applies to safety-relevant functions and systems. Comply with the relevant laws and regulations when using the corresponding functions and systems.

Washing the vehicle

General

Regularly remove foreign bodies, for example, leaves, in the area below the windscreen when the bonnet is raised.

Wash the vehicle frequently especially in winter. Very high levels of dirt and road salt can cause damage to the vehicle.

Steam-jet cleaners and high-pressure cleaners

Safety note



NOTE

When cleaning with high-pressure cleaners, excessive pressure or excessive temperatures can damage various components. There is a danger of damage to property. Ensure a sufficient distance and do not spray for an extended period of time. Comply with the instructions for the high-pressure cleaner. ◀

Distances and temperature

- ▷ Maximum temperature: 60 °C/140 °F.
- ▷ Minimum distance to sensors, cameras, seals: 30 cm, approx. 12 in.

- ▷ Minimum distance to the Glass Roof: 80 cm, approximately 31.5 in.

Automatic car washes

Safety notes



NOTE

Water can penetrate in the window area due to high pressure washers. There is a danger of damage to property. Avoid high pressure washers. ◀



NOTE

The vehicle can be damaged if automatic washing bays or car washes are used incorrectly. There is a danger of damage to property. Observe the following notes:

- ▷ Textile car washes or systems using soft brushes are preferable, to avoid damage to the paintwork.
- ▷ Avoid washing bays or car washes with guide rails higher than 10 cm, approx. 4 in, to avoid damage to the body.
- ▷ Note the maximum tyre width of the guide rail so as to avoid damage to tyres and rims.
- ▷ Fold in exterior mirrors to avoid damage to the exterior mirrors.
- ▷ Deactivate wipers and the rain sensor (if fitted) to avoid damage to the wiper system. ◀

Entering a car wash with a manual transmission

In a car wash, the vehicle must be able to roll freely.

Roll or push the vehicle, see page 95.

Entering a car wash with an M double clutch transmission with Drivelogic

Safety note



NOTE

Selector lever position P is automatically engaged when the ignition is switched off. There is a danger of damage to property. Do not switch the ignition off in car washes. ◀

General

In a car wash, the vehicle must be able to roll freely.

Roll or push the vehicle, see page 97.

Exiting from a car wash

Ensure that the remote control is located in the vehicle.

Start the engine.

Engine start, see page 86.

Headlights

Do not rub wet headlights dry and do not use abrasive or corrosive cleaning agents.

Soak impurities such as insects with shampoo and wash off with water.

Remove ice with a de-icer spray; do not use an ice scraper.

After washing the vehicle

After the vehicle has been washed, briefly apply the brakes to dry them otherwise the braking effectiveness may be temporarily reduced. The heat generated by braking dries the brake discs and brake pads, and protects them against corrosion.

Completely remove residues on the wind-screens to avoid affecting visibility due to smearing, and to reduce wiping noise and wiper blade wear.

Vehicle care

Care products

General

BMW recommends using care and cleaning products from BMW. Suitable care products are available from a Service Partner of the manufacturer or another qualified Service Partner or a specialist workshop.

Safety note



WARNING

Cleaning agents can contain hazardous substances or constitute a health risk. There is a danger of injury. When cleaning the interior, open the doors or windows. Use only products that are intended for cleaning the vehicle's interior. Observe the notes on the pack. ◀

Vehicle paintwork

General

Regular care promotes driving safety and preserves your vehicle's value. Environmental effects in areas with higher air pollution or natural contaminants, for example tree resin or leaf dust, may have an effect on the vehicle paintwork. Base the frequency and extent of vehicle care on such factors.

Immediately remove aggressive substances, for example spilled fuel, oil, grease or bird droppings so as to prevent alterations and discolourations of the paintwork.

Matt paintwork

Only use cleaning and care products that are suitable for vehicles with matt paintwork.

Leather care

Remove dust from the leather at regular intervals with a cloth or vacuum cleaner.

Dust and road dirt will otherwise become worked into pores and folds, causing consider-

able abrasion and causing the leather surface to become prematurely brittle.

In order to protect against discolouration, for example from clothing, clean and care for the leather approximately every two months.

Clean light-coloured leather more frequently as it has the tendency to soil faster.

Use leather cleaner, otherwise dirt and grease will attack the protective coating of the leather.

Care of upholstery fabrics

General

Regularly clean the upholstery with a vacuum cleaner.

In the event of heavy soiling, for example stains caused by drinks, use a soft sponge or a lint-free microfibre cloth with suitable interior cleaning agents.

Clean the upholstery down to the seams using wide wiping actions. Avoid rubbing vigorously.

Safety note



NOTE

Open Velcro fasteners on articles of clothing can damage the seat covers. There is a danger of damage to property. Make sure that any Velcro fasteners on your clothing are closed. ◀

Care of special parts

Light alloy wheels

When cleaning on the vehicle, only use neutral rim cleaner with a pH value of between 5 and 9. Do not use any abrasive cleaners or steam cleaners above 60 °C/140 °F. Observe the manufacturer's instructions.

Corrosive, acidic or alkaline cleaners may destroy the protective layer of neighbouring parts, such as brake discs, for example.

After cleaning, briefly apply the brakes to dry them. The heat generated by braking dries the

brake discs and brake pads, and protects them against corrosion.

Chrome surfaces

Carefully clean parts such as the radiator grille and door handles with plenty of water to which a shampoo may be added, particularly if exposed to road salt.

Rubber parts

The surfaces of rubber parts can be contaminated or lose their shine due to environmental influences. Only use water and suitable care products for cleaning.

Treat particularly worn rubber parts at regular intervals with rubber care products. Do not use any silicone-based care products for treating rubber seals, otherwise these could be damaged and become a source of noise.

Fine wood parts

Clean fine wood trims and fine wood parts with a damp cloth only. Then dry them with a soft cloth.

Plastic parts



NOTE

Cleaning agents containing alcohol or solvents, such as nitro thinners, cold cleansers, fuel or similar can damage plastic parts. There is a danger of damage to property. Clean with a microfibre cloth. Lightly moisten the cloth with water. ◀

Plastic parts include, for example:

- ▷ Imitation leather surfaces.
- ▷ Roof lining.
- ▷ Lamp lenses.
- ▷ Glass cover of instrument cluster.
- ▷ Parts sprayed matt black.
- ▷ Painted parts in the interior.

Clean with a microfibre cloth.

Lightly moisten the cloth with water.

Do not soak the roof lining.

Seat belts



WARNING

Chemical cleaners can cause irreparable damage to the fabric of the seat belts. The protective effect of the seat belts will be lost. There is a danger of injury or even death. Only use a mild soap and water solution for cleaning the seat belts. ◀

Dirt on the seat belt straps can interfere with the action of the reel and represents a safety hazard.

Clean only with a mild soap solution while still fitted to the vehicle.

Never allow seat belts to retract unless they are dry.

Carpets and foot mats



WARNING

Objects in the driver's footwell can restrict the pedal travel, or block a pedal that has been pressed. There is a danger of accidents. Stow items in the vehicle so that they are secure and cannot get into the driver's footwell. Only use floor mats that are appropriate for the vehicle and can be securely fastened to the floor. Do not use any loose floor mats, and do not place several floor mats on top of one another. Make sure that there is sufficient space for the pedals. Ensure that the floor mats are securely reattached after having been removed, for example for cleaning. ◀

Floor mats can be removed from the vehicle to enable the interior to be cleaned more thoroughly.

In the event of heavy soiling, clean floor carpets using a microfibre cloth and water or textile cleaner. Rub back and forth in the direction of travel to prevent matting.

Sensors/camera lenses

Clean sensors or camera lenses using a cloth moistened with a small amount of a glass cleaner.

Displays/screens/protective sleeve of the Head-Up Displays



NOTE

Chemical cleaners, moisture or fluids of all kinds can damage the surface of displays and screens. There is a danger of damage to property. Clean with a clean, anti-static microfibre cloth. ◀



NOTE

The surfaces of displays can be damaged due to improper cleaning. There is a danger of damage to property. Avoid applying excessive pressure and do not use abrasive materials. ◀

Clean with a clean, anti-static microfibre cloth.

Clean the protective sleeve of the Head-Up Display with a microfibre cloth and commercially available dishwashing liquid.

Laying up the vehicle

Special measures need to be taken if putting the vehicle out of use for longer than three months. Additional information is available from a Service Partner of the manufacturer or another qualified Service Partner or a specialist workshop.



Reference

The section contains the technical data and the alphabetical index that will enable you to find the information you need as quickly as possible.

Technical data

Vehicle equipment

This chapter describes all standard, national and special equipment available for the model series. Therefore equipment which is not installed in your vehicle, for example on account

of the selected optional equipment or the country specification, may also be described here. This also applies to safety-relevant functions and systems. Comply with the relevant laws and regulations when using the corresponding functions and systems.

General

The technical data and specifications in the Owner's Handbook are indications. The vehicle-specific data can deviate from this, for example, due to selected special equipment, country variant or country-specific measurement method. Detailed values can be found in the permit documents, on information plates

on the vehicle or can be requested from a Service Partner of the manufacturer or another qualified Service Partner or a specialist workshop.

The information in the vehicle papers always takes precedence over the information in this Owner's Handbook.

Dimensions

The dimensions can vary depending on the model version, equipment or country-specific measurement method.

The heights specified do not take into account add-on parts such as a roof aerial, roof railing

or spoiler. The heights can deviate, for example, due to selected special equipment, tyres, loads and suspension design.

BMW M4 Coupé

Width with mirrors	mm	2014
Width without mirrors	mm	1870
Height	mm	1383
Length	mm	4671
Wheelbase	mm	2812
Smallest turning circle dia.	m (ft)	12.2 (40.1)

BMW M4 CS

Width with mirrors	mm	2014
Width without mirrors	mm	1870
Height	mm	1392
Length	mm	4672
Wheelbase	mm	2812
Smallest turning circle dia.	m (ft)	12.2 (40.1)

Weights**BMW M4 Coupé**

Kerb weight, ready for road, with 75 kg, 165 lb, load, tank 90 % full, no optional extras

Manual gearbox	kg (lb)	1635 (3605)
M double clutch transmission	kg (lb)	1660 (3660)
Permitted gross weight	kg (lb)	2040 (4497)

Load

Manual gearbox	kg (lb)	480 (1058)
M double clutch transmission	kg (lb)	455 (1003)
Front axle load limit	kg (lb)	970 (2138)
Rear axle load limit	kg (lb)	1130 (2491)
Roof load	kg (lb)	75 (165)

BMW M4 CS

Kerb weight, ready for road, with 75 kg, 165 lb, load, tank 90 % full, no optional extras	kg (lb)	1655 (3649)
Permitted gross weight	kg (lb)	2040 (4497)
Load	kg (lb)	460 (1014)
Front axle load limit	kg (lb)	970 (2138)

BMW M4 CS

Rear axle load limit	kg (lb)	1130 (2491)
Roof load	kg (lb)	75 (165)

Filling capacities

	Litres/imp. gal	Note
Fuel tank, approximately.		Fuel grade, see page 206
M4 Coupé	60.0/13.2	
M4 CS	60.0/13.2	

Appendix

Here is where any updates to the Owner's Handbook for the vehicle are listed.

Updates after going to press

Updates have been made to these chapters of the printed Owner's Handbook following the copy deadline.

- ▶ Safety: front-end collision warning with City light braking function, see page [135](#).

Everything from A to Z

Index

A

- ABS, anti-lock braking system [149](#)
- Acceleration assistant, see Launch Control [99](#)
- Accessories and parts [8](#)
- Acknowledgement signals [60](#)
- Activation, airbags [128](#)
- Active bonnet, see Active pedestrian protection [129](#)
- Active M differential [152](#)
- Active pedestrian protection [129](#)
- Active Protection [146](#)
- Adaptive brake light, see Dynamic brake lights [145](#)
- Adaptive Headlights [122](#)
- Adaptive M suspension [153](#)
- Additives, oil [225](#)
- Adjusting headlights [124](#)
- After washing the vehicle [245](#)
- Age of tyres [209](#)
- Airbags [126](#)
- Airbags, indicator/warning lamp [127](#)
- Airbag switch, see Key switch for front passenger airbags [128](#)
- Air conditioning [174](#)
- Air Conditioning [171](#)
- Air distribution, manual [173](#), [176](#)
- Air flow, air conditioning [173](#)
- Air flow, automatic air conditioning [176](#)
- Air outlets, see Ventilation [177](#)
- Air pressure, tyres [207](#)
- Alarm, false [61](#)
- Alarm system [60](#)
- All-season tyres, see Winter tyres [210](#)
- Alternative oil grades [225](#)
- Ambient lighting [125](#)
- Anti-freeze protection, washer fluid [94](#)
- Anti-lock braking system, ABS [149](#)
- Anti-theft alarm system, see Alarm system [60](#)
- Anti-theft system, vehicle [49](#)
- Anti-theft system, wheel studs [217](#)
- Anti-trap mechanism, Glass Roof [64](#)
- Anti-trap mechanism, windows [62](#)
- App, BMW Driver's Guide [6](#)
- Apps, see Owner's Handbook for Navigation, Entertainment, Communication [6](#)
- Aquaplaning [193](#)
- Around the centre console [16](#)
- Around the roof lining [17](#)
- Around the steering wheel [14](#)
- Arrival time [114](#)
- Ashtray [180](#)
- Attentiveness assistant [146](#)
- AUC, automatic air recirculation control [176](#)
- AUTO intensity [175](#)
- Automatic air conditioning [171](#), [174](#)
- Automatic air recirculation control, AUC [176](#)
- Automatic anti-glare control, see High-beam assistance [123](#)
- Automatic driving lights control [121](#)
- Automatic locking [60](#)
- Automatic parking function [75](#)
- AUTO program, automatic air conditioning [175](#)
- AUTO program, intensity [175](#)
- AUTO programme, air conditioner [172](#)
- Auto Start Stop function [87](#)
- AUX-IN port, see Owner's Handbook for Navigation, Entertainment, Communication [6](#)
- Average fuel consumption [114](#)
- Average speed [114](#)
- Axle load limit [251](#)
- Axle loads, weight [251](#)

B

- Backrest contour, see Lumbar support [68](#)
- Backrest width [68](#)
- Battery, vehicle [233](#)
- Belt holder [72](#)
- Belts, seat belts [70](#)
- Black ice, see Outside temperature warning [106](#)
- Blower, see Air flow [173](#), [176](#)
- Bluetooth connection [35](#)
- Blu-ray, see Owner's Handbook for Navigation, Entertainment, Communication [6](#)
- BMW Driver's Guide app [6](#)
- BMW homepage [6](#)
- BMW internet site [6](#)

- BMW Maintenance System [229](#)
BMW M Technology [190](#)
BMW Services, see Owner's Handbook for Navigation, Entertainment, Communication
Bonnet [221](#)
Boot [182](#)
Boot lid closing [56](#)
Boot lid, contactless opening [54](#)
Boot lid, emergency release [56](#)
Boot lid emergency release [56](#)
Boot lid opening [56](#)
Boot lid via remote control [50](#)
Boot, storage compartments [187](#)
Bottle holder, see Cupholder [186](#)
Brake assist [149](#)
Brake lights, adaptive, see Dynamic brake lights [145](#)
Brake lights, dynamic [145](#)
Braking, notes [194](#)
Braking safely [194](#)
Breakdown Assist [237](#)
Breakdown assistance [238](#)
Breakdown service, Mobile Service [238](#)
Brightness of the Control Display [32](#)
Bulbs and lights [232](#)
Buttons on the steering wheel [14](#)
Button, start/stop [85](#)
- C**
- Calendar, see Owner's Handbook for Navigation, Entertainment, Communication [6](#)
Call up mirror adjustment [60](#)
Call up seat adjustment [60](#)
Camera-based assistance systems, see Intelligent Safety [134](#)
Camera lenses, care [247](#)
Camera, rear-view camera [161](#)
Camera, Side View [164](#)
Camera, Top View [165](#)
Car battery [233](#)
Carbon ceramic brakes M [190](#)
Care, displays [247](#)
Care products [245](#)
Care, vehicle [245](#)
Care, Vehicle wash [244](#)
Car jack [218](#)
Carpet, care [247](#)
Carrying children safely [77](#)
Car wash [244](#)
Car washes [244](#)
Catalytic converter, see Hot exhaust system [193](#)
CBS, Condition Based Service [229](#)
CD/Multimedia, see Owner's Handbook for Navigation, Entertainment, Communication
CD, see Owner's Handbook for Navigation, Entertainment, Communication [6](#)
Central locking system [52](#)
Central screen, see Control Display [18](#)
Centre armrest [185](#)
Centre console [16](#)
Ceramic brakes [190](#)
Changes, technical, see Your own safety [8](#)
Changing bulbs, see Replacing bulbs [232](#)
Changing gear [98](#)
Charcoal canister [177](#)
Chassis number, see Vehicle identification number [11](#)
Check Control [101](#)
Checking oil level electronically [223](#)
Child's seats [77](#)
Children, carrying [77](#)
Child restraints [77](#)
Child seat classes, ISOFIX [80](#)
Child seat mounting [79](#)
Child seat mountings, ISO-FIX [80](#)
Chrome parts, care [246](#)
Cigarette lighter [180](#)
Cleaning, displays [247](#)
Coat hooks [186](#)
Comfort Access [53](#)
Comfort closing with the remote control [49](#)
Comfort entry [49](#)
Comfort opening with the remote control [49](#)
Compatible devices, see Suitable devices [35](#)
Compound brakes [190](#)
Compressor [212](#)
Computer, see On-board computer [113](#)
Concierge Service, see Owner's Handbook for Navigation, Entertainment, Communication [6](#)
Condensation on windows [173](#), [177](#)
Condensation under the vehicle [195](#)
Condition Based Service, CBS [229](#)
ConnectedDrive, see Owner's Handbook for Navigation, Entertainment, Communication
ConnectedDrive services
Connecting a device [34](#)
Connecting a mobile telephone [34](#)
Connecting a smartphone [34](#)
Connecting a telephone [34](#)

- Connections [34](#)
Contactless opening of boot lid [54](#)
Contacts, see Owner's Handbook for Navigation, Entertainment, Communication [6](#)
Control Display [18](#)
Control Display, settings [30](#)
Controller [19](#)
Control systems, driving stability [149](#)
Coolant [227](#)
Coolant temperature [106](#)
Cooling effect, maximum [175](#)
Cooling function [172](#), [175](#)
Cooling system [227](#)
Corrosion of brake discs [195](#)
Courtesy light when unlocking [49](#)
Courtesy light with the vehicle locked [50](#)
Cruise Control [155](#)
Cruise Control without distance control, see Cruise Control [155](#)
Cupholder [186](#)
Current fuel consumption [107](#)
- D**
- Damage, tyres [208](#)
Damper control [153](#)
Data memory [9](#)
Data protection, settings [33](#)
Data, technical [250](#)
Date [31](#)
Daytime driving lights [122](#)
Deactivation, airbags [128](#)
Defrosting, see Defrosting windows [173](#), [177](#)
Defrosting windows [173](#), [177](#)
Defrost, see Defrosting windows [177](#)
Deleting personal data [33](#)
Destination input, see Owner's Handbook for Navigation, Entertainment, Communication [6](#)
Device list [34](#)
Differential lock [152](#)
Digital clock [106](#)
Digital speed [107](#)
Digital speedometer [107](#)
Dimensions [250](#)
Dimmable exterior mirrors [75](#)
Dimming rear-view mirror [75](#)
Dipping headlights, see High-beam assistance [123](#)
Display date [106](#)
Display in windscreen [116](#)
Display lighting, see Instrument lighting [124](#)
Displays, care [247](#)
Disposal, coolant [228](#)
Disposal, vehicle battery [235](#)
Distance to destination [114](#)
Distance warning, see PDC [157](#)
Double clutch transmission [95](#)
Downhill gradients [194](#)
Drinks holder, see Cupholder [186](#)
Drivelogic [98](#)
Drivelogic, gear display [107](#)
Drive mode [97](#)
Drive-off assistant [153](#)
Drive programs, see Drivelogic [98](#)
Driver assistance, see Intelligent Safety [134](#)
Driver profiles [56](#)
Driver profiles, exporting profile [58](#)
Driver profiles, import profile [58](#)
Driver's Guide app, see BMW Driver's Guide app [6](#)
Driving area [14](#)
Driving Assistant, see Intelligent Safety [134](#)
Driving dynamics, system states [108](#)
Driving dynamic systems [108](#)
Driving hints [193](#)
Driving information, general [193](#)
Driving information, running in [192](#)
Driving into a car wash [244](#)
Driving lights control, automatic [121](#)
Driving on racing tracks [191](#)
Driving out of a car wash [244](#)
Driving path lines, rear-view camera [162](#)
Driving Stability Control Systems [149](#)
Drying air, see Cooling function [172](#), [175](#)
DSC Dynamic Stability Control [150](#)
DVD, Video, see Owner's Handbook for Navigation, Entertainment, Communication [6](#)
Dynamic brake lights [145](#)
Dynamic Stability Control DSC [150](#)
- E**
- EfficientDynamics [108](#)
Electrical Glass Roof [63](#)
Electrical power windows [62](#)
Electric steering wheel lock [75](#)
Electronic oil measurement [223](#)
Electronic Stability Programme, ESP, see DSC [150](#)
e-mail, see Owner's Handbook for Navigation, Entertainment, Communication [6](#)

Emergency assistance, see Breakdown assistance [238](#)
Emergency call [237](#)
Emergency release, boot lid [56](#)
Emergency release, fuel filler flap [205](#)
Emergency service, see Mobile Service [238](#)
Emergency services, see Breakdown assistance [238](#)
Energy Control [107](#)
Energy recuperation [108](#)
Engine, automatic shut-off [87](#)
Engine, automatic start-stop function [87](#)
Engine compartment [220](#)
Engine coolant [227](#)
Engine Dynamics Control [100](#)
Engine oil [223](#)
Engine oil additives [225](#)
Engine oil change [226](#)
Engine oil filler neck [224](#)
Engine oil grades, alternative [225](#)
Engine oil grades, suitable [225](#)
Engine oil temperature [106](#)
Engine start [86](#)
Engine temperature [106](#)
Entering an address, Navigation, see Owner's Handbook for Navigation, Entertainment, Communication [6](#)
ESP, Electronic Stability Programme, see DSC [150](#)
Exhaust system [193](#)
Expanding the boot [182](#)
Extended BMW Online Services, see Owner's Handbook for Navigation, Entertainment, Communication
Exterior mirror, automatically dimming [75](#)

Exterior mirrors [74](#)
Exterior mirrors, malfunction [74](#)
External starting [239](#)

F

Failure message, see Check Control [101](#)
False alarm [61](#)
Fastening seat belts, see Seat belts [70](#)
Fault displays, see Check Control [101](#)
Favourites buttons, iDrive [26](#)
Filler neck for engine oil [224](#)
Finding charging stations, see Charging stations and points of interest, see Owner's Handbook for Navigation, Entertainment, Communication [6](#)
Fine wood, care [246](#)
First-aid kit [239](#)
Flat tyre message, RPA [133](#)
Flat tyre message, TPM [132](#)
Flat tyre, runflat indicator RPA [133](#)
Flat tyre warning lamp, RPA [133](#)
Flat tyre warning lamp, TPM [132](#)
Flat tyre, wheel change [215](#)
Flooding [193](#)
Floor carpet, care [247](#)
Fold-out position, windscreen wiper [93](#)
Foot brake [194](#)
Foot mats, care [247](#)
Front airbags [126](#)
Front-end collision with light braking function [135](#)
Front head restraints [72](#)
Front lights [233](#)
Front neck supports, see Head restraints [72](#)

Front passenger's mirror, tilting down [75](#)
Front passenger airbags, deactivating/activating [128](#)
Front passenger airbags, light [128](#)
Fuel [206](#)
Fuel consumption, see Average fuel consumption [114](#)
Fuel filler flap [204](#)
Fuel gauge [105](#)
Fuel quality [206](#)
Fuel recommendation [206](#)
Fuel tank cap [204](#)
Fuel, tank capacity [252](#)
Fuse [235](#)

G

Gearbox, manual gearbox [95](#)
Gear display, Drivelogic [107](#)
Gearshift, manual gearbox [95](#)
General driving information [193](#)
General settings [30](#)
Glare protection [180](#)
Glass Roof, electric [63](#)
Glass Roof, initialising system [64](#)
Glove box [184](#)
GPS, navigation, see Owner's Handbook for Navigation, Entertainment, Communication [6](#)
GPS positioning, vehicle position [31](#)
Ground clearance [195](#)

H

Handbrake, see Parking brake [90](#)
Hands-free kit, see Owner's Handbook for Navigation, Entertainment, Communication [6](#)

- Hazard warning lights [237](#)
- Head airbags [126](#)
- Head Light [122](#)
- Headlight cleaning system, see Wiper system [91](#)
- Headlight courtesy delay feature [121](#)
- Headlight flasher [91](#)
- Headlight lens [233](#)
- Headlights [233](#)
- Headlights, care [245](#)
- Head-Up Display [116](#)
- Head-Up Display, care [247](#)
- Head-Up Display, M View [116](#)
- Head-Up Display, see Memory function [73](#)
- Head-Up Display, standard view [116](#)
- Heavy transported loads, stowing a transported load [196](#)
- Height, vehicle [250](#)
- Help in driving off [153](#)
- High-beam assistance [123](#)
- High-beam headlights [91](#)
- High performance engine [190](#)
- Hill Start Assist, see Drive-off assistant [153](#)
- Homepage [6](#)
- Horn [14](#)
- Hot exhaust system [193](#)
- Hotline, see Owner's Handbook for Navigation, Entertainment, Communication [6](#)
- HUD Head-Up Display [116](#)
- I**
- IBA Integrated Owner's Handbook in vehicle [43](#)
- Ice warning, see Outside temperature warning [106](#)
- Identification number, see Vehicle identification number [11](#)
- iDrive [18](#)
- Ignition off [85](#)
- Ignition on [85](#)
- Important considerations [77](#)
- Important information regarding the engine compartment [220](#)
- Independent ventilation [178](#)
- Indicator and warning lamps, see Check Control [101](#)
- Indicator lamps, see Check Control [101](#)
- Indicators, see Turn indicators [90](#)
- Individual air distribution [173](#), [176](#)
- Individual settings, see Driver profiles [56](#)
- Individual settings, see M Drive [149](#)
- Inductive charging, see Wireless charging, see Owner's Handbook for Navigation, Entertainment, Communication [6](#)
- Inflation pressure, tyres [207](#)
- Inflation pressure warning, RPA, tyres [133](#)
- Info Display, see On-board computer [113](#)
- Information on no passing [111](#)
- Initialising, runflat indicator RPA [133](#)
- Initialising, Tyre Pressure Monitor TPM [130](#)
- Instrument cluster [101](#)
- Instrument cluster switch, see Turn indicators [90](#)
- Instrument cluster switch, see Wiper system [91](#)
- Instrument lighting [124](#)
- Integrated key [51](#)
- Integrated Owner's Handbook in vehicle [43](#)
- Intelligent emergency call [237](#)
- Intelligent Safety [134](#)
- Intended use [8](#)
- Intensity, AUTO Automatic programme [175](#)
- Interior light [124](#)
- Interior light when unlocking [49](#)
- Interior light with the vehicle locked [50](#)
- Interior movement detector [61](#)
- Intermittent mode [92](#)
- Internet connection [38](#)
- Internet hotspot [38](#)
- Internet site [6](#)
- Interval display, service requirements [109](#)
- ISOFIX child seat mountings [80](#)
- J**
- Jack mounting points [218](#)
- Jump-starting connection, starting assistance [240](#)
- Jump starting, see Starting assistance [239](#)
- K**
- Keyless Go, see Comfort Access [53](#)
- Key, mechanical [51](#)
- Key, see Remote control [48](#)
- Key switch for front passenger airbags [128](#)
- L**
- Labelling of recommended tyres [210](#)
- Lane boundary, warning [140](#)

Lane Change Warning [142](#)
Lane Departure Warning [140](#)
Language, on the Control Display [30](#)
Launch Control [99](#)
Laying up out of use [247](#)
Laying up, vehicle [247](#)
Leather, care [245](#)
LED light, replacing the lamps [233](#)
LEDs, light-emitting diodes [233](#)
Left-hand traffic, light setting [124](#)
Light alloy wheels, care [246](#)
Light-emitting diodes, LEDs [233](#)
Lighter [180](#)
Lighting [120](#)
Light in the exterior mirror, see Lane Change Warning [142](#)
Lights [120](#)
Light switch [120](#)
LIM button, see Manual Speed Limiter [144](#)
List of all messages [32](#)
Load [196](#)
Loading boot [196](#)
Loads [196](#)
Locking, automatic [60](#)
Locking settings [59](#)
Lock, wheel studs [217](#)
Low-beam headlights [120](#)
Low Speed Assistant [96](#)
Luggage rack, see Roof rack [197](#)
Lumbar support [68](#)

M

Maintenance [229](#)
Maintenance requirement [229](#)
Maintenance, service requirements [109](#)
Maintenance System
BMW [229](#)
Make-up mirror [180](#)
Malfunction displays, see Check Control [101](#)
Manual air distribution [173, 176](#)
Manual air flow [173, 176](#)
Manual gearbox [95](#)
Manual operation, fuel filler flap [205](#)
Manual operation, Park Distance Control, PDC [159](#)
Manual operation, rear-view camera [161](#)
Manual operation, Side View [164](#)
Manual operation, Top View [166](#)
Manual Speed Limiter [144](#)
Map update, see Owner's Handbook for Navigation, Entertainment, Communication [6](#)
Matt paintwork [245](#)
Maximum cooling effect [175](#)
Maximum speed, display [111](#)
Maximum speed range [195](#)
Maximum speed, winter tyres [210](#)
M Carbon ceramic brakes [190](#)
M compound brakes [190](#)
M differential, active [152](#)
MDM, M Dynamic Mode [151](#)
M double clutch transmission [95](#)
M Drive [149](#)
M Driver's Package, driving instructions [195](#)
M Dynamic Mode MDM [151](#)
Memory function [73](#)
M Engine Dynamics Control [100](#)
Menu in the instrument cluster [112](#)
Menus [20](#)
Messages [32](#)
Messages, see Check Control [101](#)
Microfilter [173, 177](#)
Minimum tread depth, tyres [208](#)
Mirrors [74](#)
Mirror, see Memory function [73](#)
Mirror, vanity [180](#)
Mobile communication in the vehicle [193](#)
Mobile Service [238](#)
Mobile Service, see Breakdown assistance [238](#)
Mobility System [212](#)
Moisture in the headlight [233](#)
Monitor, see Control Display [18](#)
Mounting child restraints [79](#)
MP3 player, see Audio, see Owner's Handbook for Navigation, Entertainment, Communication [6](#)
M Technology [190](#)
Multifunction steering wheel, buttons [14](#)
Music hard disc, see Owner's Handbook for Navigation, Entertainment, Communication [6](#)
M View, Head-Up Display [116](#)

N

Navigation, see Owner's Handbook for Navigation, Entertainment, Communication
Neutral cleaner, see Rim cleaner [246](#)
New wheels and tyres [209](#)
No Passing Information [111](#)
Notes [6](#)

Notes, see Owner's Handbook for Navigation, Entertainment, Communication **6**

O

OBD, see On-board diagnosis, OBD **230**

Obstacle marking, rear-view camera **162**

Octane number, see Petrol grade **206**

Odometer **106**

Office, see Owner's Handbook for Navigation, Entertainment, Communication

Oil **223**

Oil additives **225**

Oil change **226**

Oil change interval, service requirements **109**

Oil filler neck **224**

Oil grades, alternative **225**

Oil grades, suitable **225**

Old battery, disposing **235**

On-board computer **113**

On-board diagnosis, OBD **230**

On-board monitor, see Control Display **18**

On-board tool kit **232**

Online entertainment, see Owner's Handbook for Navigation, Entertainment, Communication **6**

Opening and closing **48**

Operating menus, iDrive **18**

Operating principle, iDrive **18**

Operation by touchscreen **23**

Operation via Controller **20**

Operation via iDrive **20**

Outside air, see AUC **176**

Outside temperature display **106**

Outside temperature warning **106**

Overheating of the engine, see Coolant temperature **106**

P

Paintwork, vehicle **245**

Pairing, see Registering **34**

Park Assistant **167**

Park Distance Control PDC **157**

Parked vehicle, condensation **195**

Parking aid, see PDC **157**

Parking assistant **167**

Parking brake **90**

Parking lights **120**

Part replacement **232**

Parts and accessories **8**

PDC Park Distance Control **157**

Pedestrian protection, active **129**

Personal data, delete **33**

Personal profile, see Driver profiles **56**

Person warning with City light braking function **138**

Petrol **206**

Petrol grade **206**

Place for children **77**

Plasters, see First-aid kit **239**

Plastic, care **246**

Pockets in the doors **185**

Positioning, vehicle position **31**

PostCrash **147**

Power failure **234**

Power socket **181**

Power windows **62**

Prescribed engine oil grades **225**

Pressure check, tyres **130**

Pressure, tyres **207**

Pressure warning RPA, tyres **133**

Preventing Auto Start Stop **89**

Profiles, see Driver profiles **56**

Protection function, Glass Roof **64**

Protection function, windows **62**

R

Racing track driving **191**

Radio ready state **86**

Radio, see Owner's Handbook for Navigation, Entertainment, Communication

Radio signals **193**

Rain sensor **92**

Range **107**

Readiness service, see Mobile Service **238**

Rear backrests, folding down **182**

Rear fog light **124**

Rear lights **233**

Rear-view camera **160**

Rear-view mirror, automatic-dim **75**

Rear window heating **173, 177**

Recirculated-air mode **172, 176**

Recirculating air filter **177**

Recirculation, see Recirculated-air mode **172, 176**

Recommended tyre makes **210**

Recycling **231**

Refuelling **204**

Remaining distance **107**

Remedying flat tyres **210**

Remote control, additional **51**

- Remote control for audio, see Owner's Handbook for Navigation, Entertainment, Communication **6**
- Remote control, integrated key **51**
- Remote control, loss **51**
- Remote control, malfunction **51**
- Remote control, opening/closing **48**
- Remote operation, opening/closing **48**
- Remote services, app, see Owner's Handbook for Navigation, Entertainment, Communication **6**
- Replacement of parts **232**
- Replacement of wheels/tires **209**
- Replacing bulbs **232**
- Replacing parts **232**
- Replacing the battery, vehicle battery **234**
- Replacing the battery, vehicle remote control **50**
- Replacing the lamps, front **233**
- Replacing the lamps, LED headlights **233**
- Replacing the lamps, rear **233**
- Replacing the lights, front **233**
- Replacing the lights, rear **233**
- Replacing the wiper blades **232**
- RES button, see Cruise Control **155**
- Reserve warning, see Range **107**
- Reservoir for washer fluid **94**
- Reset, Tyre Pressure Monitor TPM **130**
- Restraint systems for children **77**
- Retreaded tyres **210**
- Reuse **231**
- Reversing light **233**
- Revolution counter **105**
- Right-hand traffic, light setting **124**
- Rim cleaner **246**
- Roller sunblinds **63**
- RON petrol grade **206**
- Roof lining **17**
- Roof load **251**
- Roof rack **197**
- Route, navigation, see Owner's Handbook for Navigation, Entertainment, Communication **6**
- RPA runflat indicator **133**
- RTTI, see Owner's Handbook for Navigation, Entertainment, Communication **6**
- Rubber parts, care **246**
- Runflat indicator RPA **133**
- Running in **192**
- Running in brake discs **192**
- Running in brake pads **192**
- ## S
- Safe seating position **66**
- Safety package, see Active Protection **146**
- Safety systems, airbags **126**
- Saving fuel **199**
- Screen, see Control Display **18**
- Screwdriver, see On-board tool kit **232**
- Sealant, see Mobility System **212**
- Seat belt reminder for driver and front passenger seat **72**
- Seat belt reminder for rear seats **72**
- Seat belts **70**
- Seat belts, care **247**
- Seat heating, front **69**
- Seat, see Memory function **73**
- Securing a transported load **196**
- Selection list in the instrument cluster **112**
- Selector lever **96**
- Selector lever position **96**
- Sensors, care **247**
- Sequential mode **97**
- Service history **110**
- Service, mobile **238**
- Service requirements, Condition Based Service CBS **229**
- Service requirements, display **109**
- Services, ConnectedDrive Service, see Breakdown assistance **238**
- Servotronic **154**
- Settings, locking/unlocking **59**
- Settings, M Drive **149**
- Settings on the Control Display **30**
- Shift Lights **118**
- Shift paddles on the steering wheel **98**
- Shift point indicator **110**
- Side airbags **126**
- Side lights **120**
- Side View **163**
- Signals on unlocking **60**
- Sizes **250**
- Sliding/tilting roof **63**
- Smallest turning circle **250**
- SMS, see Short messages, see Owner's Handbook for Navigation, Entertainment, Communication **6**
- Snow chains **215**
- Socket in rear passenger compartment **181**
- Socket, on-board diagnosis, OBD **230**

- Software update [41](#)
- SOS button [237](#)
- Sound output, see Owner's Handbook for Navigation, Entertainment, Communication [6](#)
- Sound, see Owner's Handbook for Navigation, Entertainment, Communication
- Spanner, see On-board tool kit [232](#)
- Special equipment [7](#)
- Speed Limit Device, see Manual Speed Limiter [144](#)
- Speed limit, display [111](#)
- Speed limiter, manual [144](#)
- Speed Limit Info [111](#)
- Speed Limit Info, on-board computer [114](#)
- Speed limit, see Manual Speed Limiter [144](#)
- Speed warning [115](#)
- Split screen [25](#)
- Split screen view, split screen [25](#)
- Sport displays, torque display, power display [115](#)
- Stability control systems [149](#)
- Standard equipment [7](#)
- Standard view, Head-Up Display [116](#)
- Start/stop button [85](#)
- Starting assistance [239](#)
- Starting assistance, see DSC [150](#)
- Starting, see Engine start [86](#)
- Starting the engine [86](#)
- Starting the engine, starting assistance [239](#)
- Stations, AM/FM, see Owner's Handbook for Navigation, Entertainment, Communication [6](#)
- Status Control Display, tyres [130](#)
- Status information, iDrive [25](#)
- Status of the Owner's Handbook [7](#)
- Status, vehicle [118](#)
- Steering assistance [154](#)
- Steering wheel, adjusting [75](#)
- Steering wheel heating [76](#)
- Stopping the engine [87](#)
- Storage compartments [184](#)
- Storage options [184](#)
- Storage, tyres [210](#)
- Storage, vehicle [247](#)
- Stowing and securing a transported load [196](#)
- Suitable devices [35](#)
- Suitable engine oil grades [225](#)
- Suitable mobile telephones [35](#)
- Summer tyres, tread [208](#)
- Sunblinds, sun guard [63](#)
- Sun visor [180](#)
- Supplementary text message [105](#)
- Surround view [160](#)
- Suspension, electronic [153](#)
- Switches, see Driving area [14](#)
- Switching off the engine [87](#)
- Switch-on times, independent ventilation [178](#)
- Symbols [6](#)
- Symbols in the status field [25](#)
- Symbols used [6](#)
- System states of the driving dynamics [108](#)
- ## T
- Tail lights [233](#)
- Tank display [105](#)
- Technical changes, see Your own safety [8](#)
- Technical data [250](#)
- Technology, BMW M [190](#)
- Telephone, see Owner's Handbook for Navigation, Entertainment, Communication
- Teleservices, see Owner's Handbook for Navigation, Entertainment, Communication [6](#)
- Television, TV, see Owner's Handbook for Navigation, Entertainment, Communication [6](#)
- Temperature, automatic air conditioning [172](#), [174](#)
- Temperature display, outside temperature [106](#)
- Temperature, engine oil [106](#)
- Text message, supplementary [105](#)
- Thiefproof wheel studs [217](#)
- Tilt alarm sensor [61](#)
- Tilting down, front passenger's mirror [75](#)
- Time [30](#)
- Tool [232](#)
- Topping up engine oil [224](#)
- Top View [164](#)
- Total weight [251](#)
- Total weight, permitted [251](#)
- Touchpad [24](#)
- Touchscreen [23](#)
- Tourist function, see Left-hand/right-hand traffic [124](#)
- Towing away [240](#)
- Towing, see Tow-starting and towing [240](#)
- Tow-starting [240](#)
- TPM Tyre Pressure Monitor [130](#)
- Traffic information, see Owner's Handbook for Navigation, Entertainment, Communication [6](#)
- Transported load, stowing and securing [196](#)
- Tread, tyres [208](#)
- Trip computer [114](#)
- Trip distance recorder [106](#)

Triple turn signal [90](#)
Turn indicator rear, replacing the lamps [233](#)
Turn indicators, operation [90](#)
Turning circle [250](#)
Turning circle lines, rear-view camera [162](#)
TV, see Owner's Handbook for Navigation, Entertainment, Communication [6](#)
Tyre damage [208](#)
Tyre inflation pressure [207](#)
Tyre pressure monitoring, see RPA [133](#)
Tyre Pressure Monitor TPM [130](#)
Tyre repair kit, see Mobility System [212](#)
Tyre replacement [209](#)
Tyre sealant, see Mobility System [212](#)
Tyres, everything about wheels and tyres [207](#)
Tyre tread [208](#)

U

Units of measure [31](#)
Unloaded weight [251](#)
Unlocking, settings [59](#)
Updates after going to press [7](#)
Upholstery care [246](#)
USB connection [37](#)
USB interface, position in the vehicle [181](#)
USB port, see USB interface [181](#)
Use, intended [8](#)

V

Vanity mirror [180](#)
Vehicle battery [233](#)
Vehicle battery, changing [234](#)

Vehicle care [245](#)
Vehicle equipment [7](#)
Vehicle identification number [11](#)
Vehicle paintwork [245](#)
Vehicle position, vehicle positioning [31](#)
Vehicle, running in [192](#)
Vehicle status [118](#)
Vehicle wash [244](#)
Ventilation [177](#)
Ventilation, see Independent ventilation [178](#)
VIN, see Vehicle identification number [11](#)
Voice control, see Owner's Handbook for Navigation, Entertainment, Communication [6](#)
Voice control system [27](#)

W

Wading [193](#)
Warning and indicator lamps, see Check Control [101](#)
Warning indicators, see Check Control [101](#)
Warning lamp in the exterior mirror, see Lane Change Warning [142](#)
Warning messages, see Check Control [101](#)
Warning triangle [239](#)
Warranty [8](#)
Washer fluid [94](#)
Washer jets, windows [93](#)
Washing, vehicle [244](#)
Wash system [244](#)
Water on roads [193](#)
Weights [251](#)
Welcome lights [121](#)
Welcome light when unlocking [49](#)
Wheelbase, vehicle [250](#)
Wheel change [215](#)

Wheel replacement [209](#)
Wheels, everything about wheels and tyres [207](#)
Wheels, runflat indicator RPA [133](#)
Width, vehicle [250](#)
WiFi connection [38](#)
Windscreen washer jets [93](#)
Windscreen washing system [91](#)
Windscreen wipers, see Wiper system [91](#)
Winter storage, care and maintenance [247](#)
Winter tyres, right tyres [210](#)
Winter tyres, tread [208](#)
Wiper, fold-out position [93](#)
Wipers [91](#)
Wiper system [91](#)
Wireless charging dock, see Owner's Handbook for Navigation, Entertainment, Communication [6](#)
Wireless charging, see Wireless charging, see Owner's Handbook for Navigation, Entertainment, Communication [6](#)
Wood, care [246](#)
Wordmatch principle, navigation [22](#)
Working in the engine compartment [221](#)

Y

Your own safety [8](#)

BMW M



The Ultimate
Driving Machine

01402981699 en

