

# Contents

## A-Z

BMW M



The Ultimate  
Driving Machine



# THE BMW M4 COUPÉ.

## OWNER'S HANDBOOK.



## **M4** **Owner's Handbook for the vehicle**

Congratulations on your choice of a BMW M4.

The better you are acquainted with your vehicle, the easier you will find it is to handle. We would therefore like to offer you the following advice:

Please read the Owner's Handbook before setting out in your new BMW M4. Also use the integrated Owner's Handbook in your vehicle. It contains important information on how to operate the vehicle, enabling you to derive maximum benefit from the technical advantages of your BMW M4. It also contains useful information which will help you to uphold both your BMW M4's operating safety and its full resale value.

If applicable, you will find updates after the editorial deadline in the appendix of the printed Owner's Handbook for the vehicle.

Supplementary information is provided in the other documents of on-board literature.

We wish you a safe and enjoyable journey,

BMW AG

The Owner's Handbook is available as an app in many countries. You will find further information on the Internet at:

[www.bmw.com/bmw\\_drivers\\_guide](http://www.bmw.com/bmw_drivers_guide)

© 2015 Bayerische Motoren Werke  
Aktiengesellschaft  
Munich, Germany  
Not to be reproduced, wholly or in part, without written  
permission from BMW AG, Munich.  
English VI/15, 07 15 490  
Printed on environmentally friendly paper, bleached  
without chlorine, suitable for recycling.

# Contents

For quick access to a particular topic or item, please consult the detailed alphabetical index, see page 218.

6 Notes

## Overview

12 Cockpit  
16 iDrive  
25 Voice control system  
28 Integrated Owner's Handbook in the vehicle

## Controls

32 Opening and closing  
48 Adjusting  
58 Carrying children in safety  
65 Driving  
79 Displays  
98 Lights  
104 Security  
123 Driving stability control systems  
129 Driving comfort  
144 Climate  
149 Interior equipment  
153 Storage compartments

## Driving hints

160 BMW M4 Technology  
162 Driving precautions  
166 Loads  
168 Saving fuel

## Mobility

172 Refuelling  
174 Fuel  
175 Wheels and tyres  
182 Engine compartment  
185 Engine oil  
189 Coolant  
191 Maintenance  
193 Replacing parts  
202 Help in the event of a breakdown  
208 General care

## Reference

214 Technical data  
216 Appendix  
218 Everything from A to Z

# Notes

## About this Owner's Handbook

### Orientation

The quickest access to a particular topic or item is by consulting the alphabetical index.

The first chapter is recommended for an initial overview of the vehicle.

### Updates after going to press

If applicable, you will find updates after the editorial deadline in the appendix of the printed Owner's Handbook for the vehicle.

### Owner's Handbook for Navigation, Entertainment, Communication

The topics of navigation, entertainment, communication and short commands of the voice input system can be called up through the integrated Owner's Handbook on the Control Display.

## Additional sources of information

The Service Partner or a qualified specialist workshop will be happy to answer any further questions.

Information on BMW, for example on technology, on the Internet: [www.bmw.com](http://www.bmw.com).

### BMW Driver's Guide App

The Owner's Handbook is available as an app in many countries. You will find further information on the Internet at:

[www.bmw.com/bmw\\_drivers\\_guide](http://www.bmw.com/bmw_drivers_guide)

## Symbols and displays

### Symbols in the Owner's Handbook

 Indicates precautions that must be followed precisely in order to avoid the possibility of personal injury and serious damage to the vehicle.

◀ Marks the end of a specific item of information.

 Refers to measures that can be taken to help protect the environment.

"..." identifies texts on a display in the vehicle for selecting functions.

>...< Identifies commands for the voice control system.

>>...<< Identifies replies by the voice control system.

### Handling steps

The handling steps to be carried out are shown as a numbered list. The sequence of steps must be followed.

1. First handling step.
2. Second handling step.

### Lists

Lists without a mandatory sequence or alternative possibilities are shown as a list with bullet points.

- ▷ First possibility.
- ▷ Second possibility.

### Symbol for components and assemblies

 Recommends that you study the relevant section of this Owner's Handbook in connection with a particular part or assembly.

## Vehicle equipment

This Owner's Handbook describes all models and all standard, national and special equipment provided in the model series. This Owner's Handbook may contain descriptions and illustrations of equipment not featured in your vehicle, for example due to selected special equipment or national version.

This also applies to safety-relevant functions and systems.

Comply with the relevant national regulations when using the corresponding functions and systems.

If certain equipment and models are not described in this Owner's Handbook, refer to the Supplementary Owner's Handbooks provided.

In right-hand drive vehicles, some control functions are arranged differently from those shown in the illustrations.

## Built-date

The 'built-date' of your vehicle is indicated underneath the door post on the driver's door.

The 'built-date' is defined as 'the calendar month and the calendar year in which the body shell and the powertrain subassemblies are conjoined and the vehicle is driven or moved from the production line'.

## Status of the Owner's Handbook

### General

The high level of safety and quality of vehicles is ensured by continuous enhancement. In rare instances, your car may therefore differ from the information supplied here.

### For Australia/New Zealand: general

When reading this Owner's Handbook, please bear the following in mind: to ensure that our

vehicles continue to embody the highest quality and safety standards, we pursue a policy of continuous, ongoing development. Because modifications in the design of both vehicles and accessories may be introduced at any time, your own vehicle's equipment may vary from that described in this handbook. For the same reason, it is also impossible to guarantee that all descriptions will be completely accurate in all respects.

We must therefore request your understanding of the fact that the manufacturer of your vehicle is unable to recognise legal claims based on discrepancies between the data, illustrations and descriptions in this Owner's Handbook and your own vehicle's equipment. Please note, too, that some of the optional equipment described in this handbook is not available on Australian models due to restrictions imposed by Australian Design Rules and other requirements.

Should you require any further information, please contact your Service Partner or a qualified specialist workshop, who will be pleased to advise you.

### Updates after going to press

If applicable, you will find updates after the editorial deadline in the appendix of the printed Owner's Handbook for the vehicle.

## Your own safety

### Warranty

Your vehicle is technically designed for the operating conditions and permit requirements prevalent in the country to which it was first delivered - approval. If your vehicle is to be operated in another country, it may have to be adapted to any prevailing different operating conditions and permit requirements. If your vehicle does not comply with the homologation requirements in a certain country you cannot lodge warranty claims for your vehicle there.

Further information is available from a Service Partner or a qualified specialist workshop.

## Maintenance and repair

Advanced technology behind this vehicle, for example the use of modern materials and high-performance electronics, necessitates adapted methods of maintenance and repair.

The manufacturer of the vehicle recommends having respective work carried out by a BMW Service Partner or a qualified specialist workshop. Qualified specialist workshop in this Owner's Handbook refers to a workshop carrying out respective work, e.g. maintenance and repair, according to BMW specifications with respectively trained personnel.

If such work, e.g. maintenance and repair, is performed inexpertly, it could result in consequential damage and thus constitute a safety risk.

## Parts and accessories

BMW recommends using parts and accessory products that are approved by BMW and thus categorised as suitable.

The manufacturer of your vehicle recommends to consult with a BMW Service Partner prior to purchasing spare parts, operating materials or accessories. The BMW Service Partner informs about genuine BMW parts and accessories, other BMW approved products and offers expert advice on all related matters.

The safety and compatibility of genuine BMW parts and accessories in conjunction with BMW vehicles have been checked by BMW.

BMW accepts product liability for them. On the other hand, BMW cannot accept liability for unsuitable parts or accessory products of any kind.

BMW does not evaluate each individual product of outside origin as to its suitability for use on BMW vehicles without safety risk. BMW does not evaluate the suitability of products, even if a country-specific official approval was

issued. BMW cannot evaluate, whether these products are suitable for BMW vehicles under all usage conditions.

## Data memory

Many of the electronic components of your vehicle contain data memories, which save technical information on vehicle condition, events and errors temporarily or permanently. This technical information documents the condition of a component, a module, a system or its environment:

- ▷ Operating states of system components, for example, fill levels.
- ▷ Status messages of the vehicle and individual components, for example, wheel rotation number/speed, movement delay, transverse acceleration.
- ▷ Malfunctions and faults of important system components, for example, lights and brakes.
- ▷ Responses of the vehicle to special driving situations, for example, triggering of an airbag, using the stability control systems.
- ▷ Ambient conditions, for example, temperature.

This data is only of a technical nature and is for detecting and rectifying faults and optimisation of vehicle functions. Movement profiles over driven routes cannot be created from this data. When servicing, for example, during repairs, service processes, warranty cases or quality assurance, this technical information can be read by employees of the Service Partner or a qualified specialist workshop, including the manufacturer, from the event and fault data memories with special diagnostic tools. There, you will receive further information as needed. After rectifying the fault, the information in the fault memory is deleted or continuously overwritten.

When using the vehicle, situations are conceivable in which this technical data can be per-

sonal in connection with other information, for example, accident report, damage to the vehicle, witness statements, etc. — possibly by enlisting the help of an expert.

Additional functions, contractually agreed with the customer, for example vehicle location in an emergency, allow certain pieces of vehicle data to be transferred from the vehicle.

## Vehicle identification number

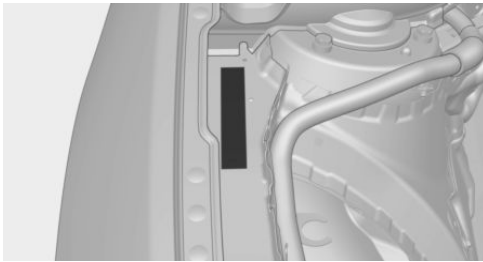

The vehicle identification number is in the engine compartment.



## Overview

This summary of buttons, switches and displays serves as an initial guide.

In addition, it gives you an insight into the principles behind the various ways in which functions can be performed.

# Cockpit

## Vehicle equipment

This chapter describes all standard, national and special equipment provided in the model series. Equipment not available in the vehicle is therefore also described, for example the se-

lected special equipment or national version. This also applies to safety-relevant functions and systems. Comply with the relevant national regulations when using the corresponding functions and systems.

## Around the steering wheel

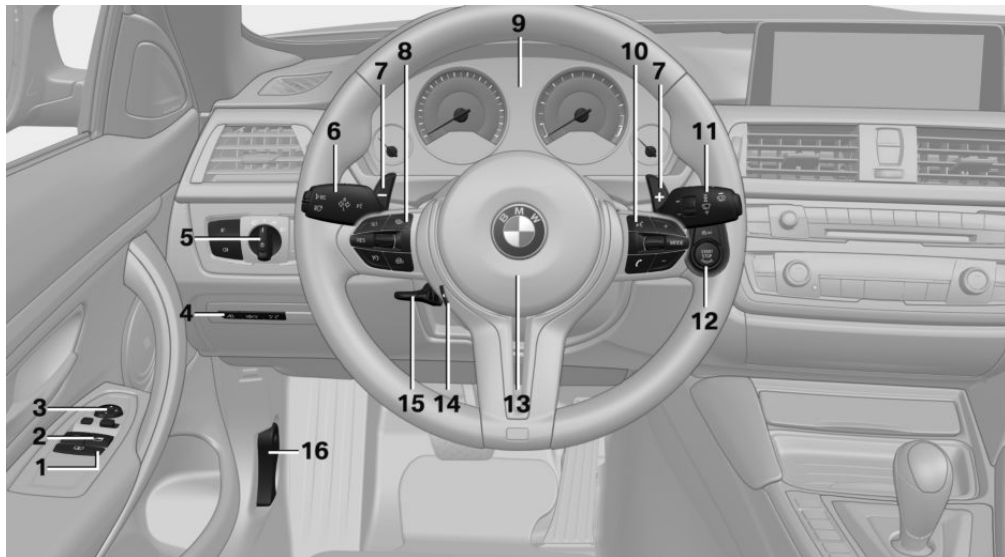

1 Roller sunblinds [45](#)

2 Power windows [43](#)

3 Exterior mirror operation [55](#)

4 Glove box on the driver's side [153](#)

### Driver Assistance Systems



Lane change warning [117](#)



Intelligent Safety [110](#)



Lane departure warning [115](#)

5 Lights



Rear fog lights [102](#)

























Lights off  
Daytime driving lights [100](#)



Side lights [98](#)



Low-beam headlights [98](#)

-  Automatic driving lights control [99](#)  
Adaptive Headlights [100](#)  
High-beam assistance [100](#)
-  Instrument lighting [102](#)
- 6** Steering-column lever, left
-  Turn indicator [70](#)
-  High-beam headlights, headlight flasher [70](#)
-  High-beam assistance [100](#)
-  Parking lights [99](#)
-  On-board computer [90](#)
- 7** Shift paddles [76](#)
- 8** Buttons on steering wheel, left
-  Activate M Drive 1 [123](#)
-  Activate M Drive 2 [123](#)
-  Speed limiter [119](#)
-  Resume speed [129](#)
-  Cruise Control on/off, interrupt [129](#)  
Rocker switch for Cruise Control [129](#)
- 9** Instrument cluster [79](#)
- 10** Buttons on steering wheel, right
-  Entertainment source
-  Volume control
-  Voice control [25](#)
-  Telephone
- Knurled wheel for selection lists [90](#)
- 11** Steering-column lever, right
-  Wiper [71](#)
-  Rain sensor [71](#)
-  Cleaning the windows and headlights [72](#)
- 12**  Start/stop engine and switch ignition on/off [66](#)
-  Auto Start Stop function [67](#)
- 13** Horn, total area
- 14**  Steering wheel heating [57](#)
- 15** Steering wheel adjustment [57](#)
- 16** Unlock bonnet [183](#)

## Around the centre console

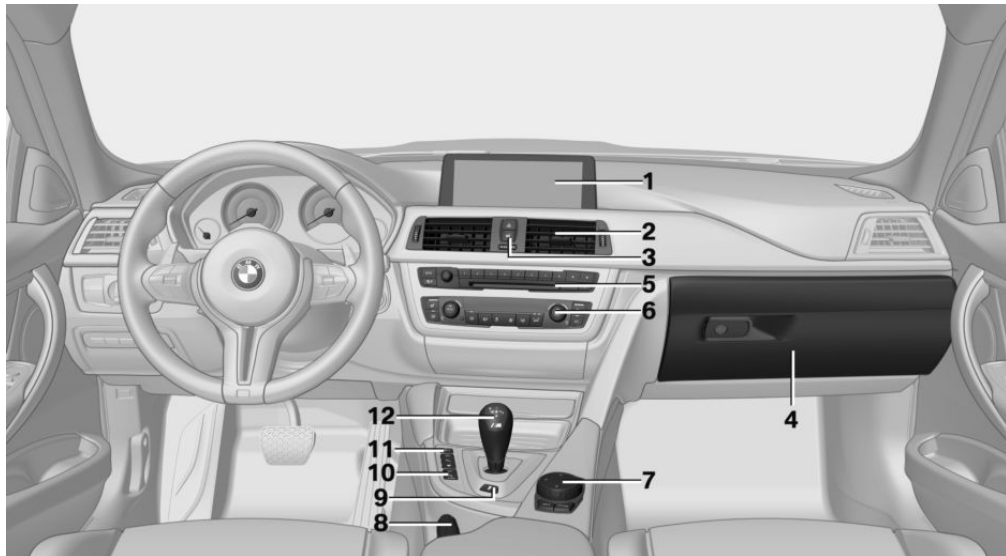

1 Control Display [16](#)

2 Ventilation [147](#)

3  hazard warning lights [202](#)



Central locking system [38](#)

4 Glove box [153](#)

5 Radio/CD/Multimedia

6 Climate [144](#)

7 Controller with buttons [17](#)

8 Parking brake [69](#)

9  Drivelog [76](#)

10  Park Distance Control, PDC [131](#)

Rear view camera [133](#)

Park assistant [139](#)

Surround view [133](#)



Side View [136](#)

11  Dynamic Stability Control, DSC [124](#)



Engine Dynamics [78](#)



Adaptive M chassis [126](#)







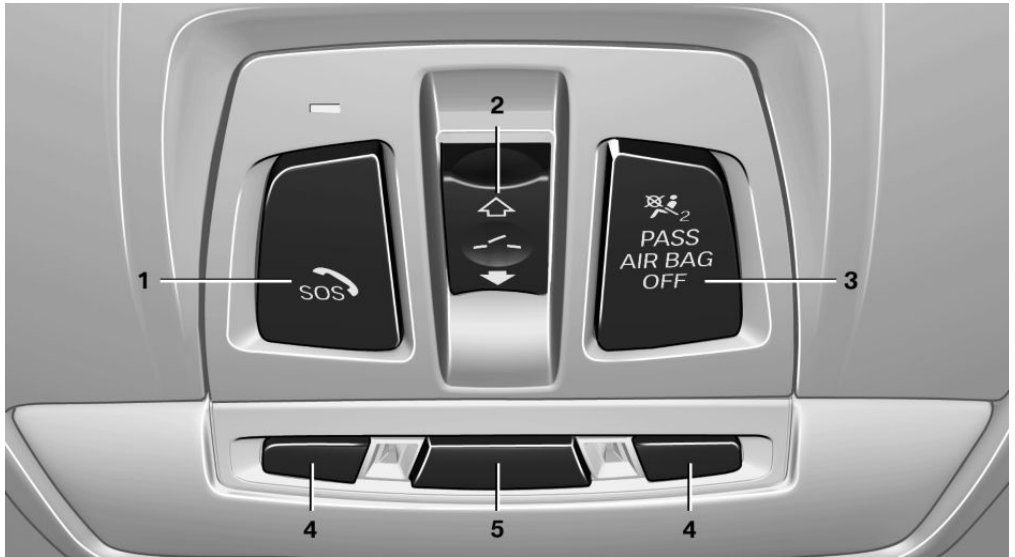

Servotronic [127](#)

12 M double clutch transmission selector lever 74

Manual gearbox selector lever 73

## Around the headlining



- |   |   |   |   |  |                    |
|---|---|---|---|--|--------------------|
| 1 |    | Intelligent emergency call 202            | 4 |   | Reading lights 102 |
| 2 |   | Glass Roof, electric 45                   | 5 |  | Interior light 102 |
| 3 |  | Front passenger airbag indicator lamp 106 |   |  |                    |

# iDrive

## Vehicle equipment

This chapter describes all standard, national and special equipment provided in the model series. Equipment not available in the vehicle is therefore also described, for example the selected special equipment or national version. This also applies to safety-relevant functions and systems. Comply with the relevant national regulations when using the corresponding functions and systems.

## Principle

iDrive integrates the functions of a large number of switches. These functions can therefore be controlled from one central point.

### WARNING

Operating integrated information systems and communication devices during the journey can distract from traffic. You could lose control of the vehicle. Danger of accidents. Only operate the systems or devices if permissible in the traffic situation. Stop if necessary and operate the systems or devices with the vehicle at a standstill. ◀

## Overview of controls

### Control functions



- 1 Control Display
- 2 Controller with buttons and touchpad, depending on equipment

### Control Display

#### Information

- ▶ To clean the Control Display, comply with the information regarding care.
- ▶ To avoid risk of damage to the Control Display, do not place objects in front of it.
- ▶ At very high temperatures on the Control Display, for example because of intensive sunshine, there may be a reduction in brightness and the Control Display may even switch itself off. Normal functions will be restored when the temperature is reduced, for example by shading or using the air conditioning system.

#### Switching on

1. Switch on ignition.
2. Press the Controller.

#### Switching off

1.  Press the button.

## 2. "Switch off control display"

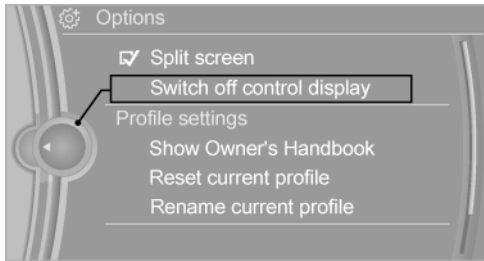

## Controller with navigation system

The buttons can be used to call up menus directly. The Controller can be used to select menu items and alter settings.

Some of the functions of the iDrive can be operated with the touchpad of the Controller.

### 1. Turning.

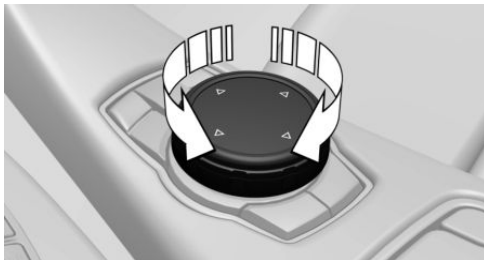

### 2. Pressing.



### 3. Tilting in four directions.

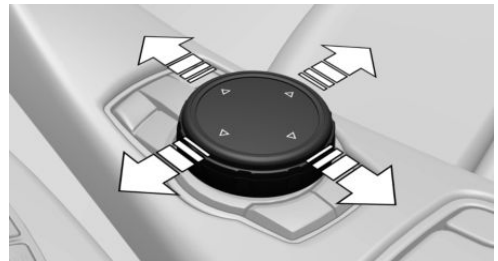

## Buttons on the Controller

Press the button	Function
MENU	Calls up the main menu.
RADIO	Calls up the Radio menu.
MEDIA	Calls up the multimedia menu.
NAV	Calls up the Navigation menu.
TEL	Calls up the Telephone menu.
BACK	Displays the previous screen.
OPTION	Calls up the Options menu.

## Controller without navigation system

The buttons can be used to call up menus directly. The Controller can be used to select menu items and alter settings.

### 1. Turning.

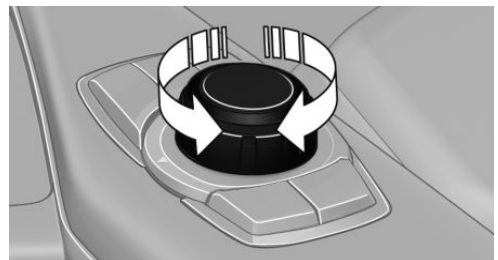

## 2. Pressing.

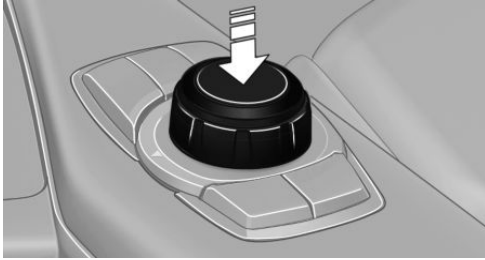

## 3. Tilting in four directions.

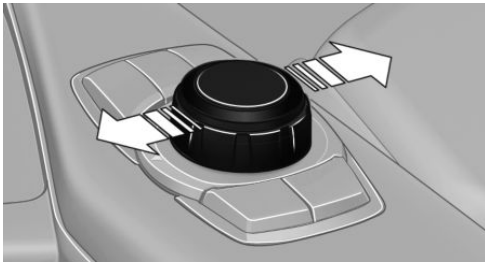

## Buttons on the Controller

Press the button	Function
MENU	Calls up the main menu.
AUDIO	Calls up last heard audio menu, change between audio menus.
TEL	Calls up the Telephone menu.
BACK	Call up previous table.
OPTION	Calls up the Options menu.

## Operating principle

### Calling up the main menu

 Press the button.

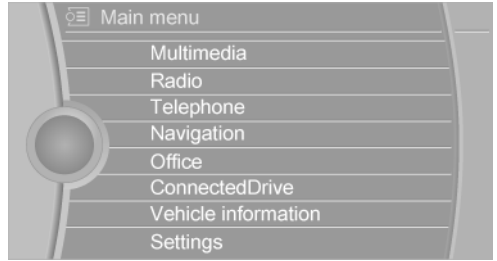

The main menu is displayed.

All iDrive functions can be called up via the main menu.

### Selecting a menu item

Highlighted menu items can be selected.

1. Turn the Controller until the desired menu item is highlighted.

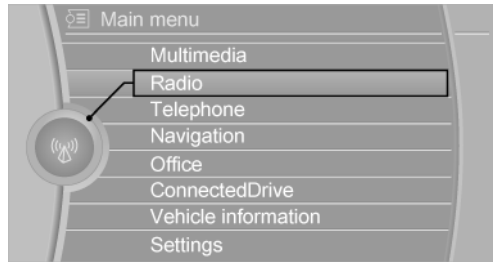

2. Press the Controller.

### Menu items in the Owner's Handbook

In this Owner's Handbook, the menu items that are to be selected are shown in quotation marks, for example "Settings".

### Switching between screens

After a menu item has been selected, for example "Radio", a new screen is displayed. Screens can appear one on top of the other.

- ▶ Tilt the Controller to the left.

The current screen is closed and the previous screen is displayed.

Pressing the BACK button reopens the previous screen. The current screen is not closed.

- ▶ Tilt the Controller to the right.  
A new screen is opened and overlaid.

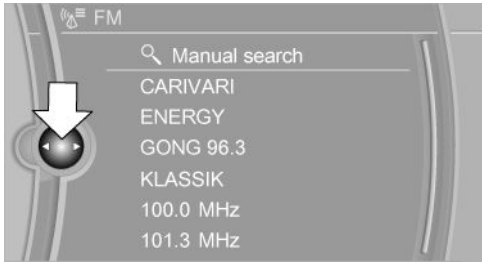

White arrows to the left or right indicate that other screens can be called up.

## Calling up the Options menu



Press the button.

The "Options" menu is displayed.

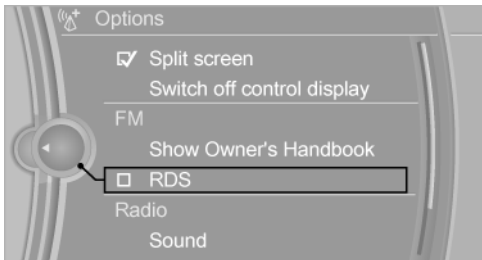

Alternatively, tilt the Controller repeatedly to the right until the "Options" menu is displayed.

## Options menu

The "Options" menu consists of various areas:

- ▶ Screen settings, for example "Split screen".
- ▶ Operating options for the selected main menu, for example for "Radio".
- ▶ If applicable, other operating options for the selected main menu, for example "Save station".

## Adjusting the settings

1. Select a field.

2. Turn the Controller until the desired setting is displayed.

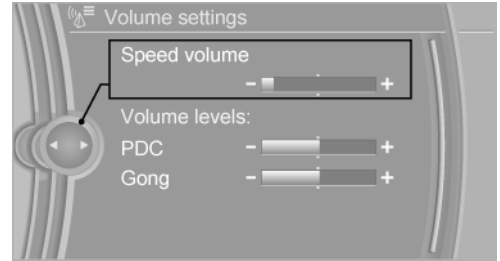

3. Press the Controller.

## Enabling/disabling functions

Some menu items are preceded by a checkbox. This indicates whether the function is enabled or disabled. Selecting the menu item enables or disables the function.

- Function is enabled.
- Function is disabled.

## Touchpad

Some of the functions of the iDrive can be operated with the touchpad of the Controller:

## Selecting functions

1. "Settings"
2. "Touchpad"
3. Select desired functions.
  - ▶ "Write": enter letters and numbers.
  - ▶ "Interactive map": operate interactive card.
  - ▶ "Browser": enter Internet addresses.
  - ▶ "Audio feedback": the letters and numbers entered are read out.

## Entering letters and numbers

Entering letters requires a bit of practice to begin with. Pay attention to the following when entering:

- ▶ The system recognises capital and small letters. To enter small and capital letters and numbers, it may be necessary to the change input mode, for example, when identically writing small and capital letters. Change between upper/lower case, numbers and symbols, see page 23.
- ▶ Enter symbols as they are displayed on the Control Display.
- ▶ Relevant symbols, such as accents or full stops are always known ambiguously with the letter. The input option depends on the language that has been set. You may need to enter special characters using the Controller.
- ▶ To delete a character, swipe the touchpad towards the left.
- ▶ To enter a space, swipe towards the right in the middle of the touchpad.
- ▶ To enter a hyphen, swipe towards the right in the upper area of the touchpad.
- ▶ To enter an underscore, swipe towards the right in the lower area of the touchpad.

## Operating interactive map and Internet

The Interactive map of the navigation system and websites can be moved using the touchpad.

Function	Controls
Move interactive map or web pages.	Swipe in the appropriate direction.
Enlarge/reduce interactive map or web pages.	Pinch or open up your fingers on the touchpad.
Show menu or open a link on the Internet.	Tap once.

## Adjusting the settings

Settings on the Control Display, such as volume, for example, can be made using the

touchpad. To do this swipe left or right as appropriate.

## Example: setting the clock

### Setting the clock

On the Control Display:

1.  Press the button. The main menu is displayed.
2. Turn the Controller until "Settings" is highlighted and press the Controller.

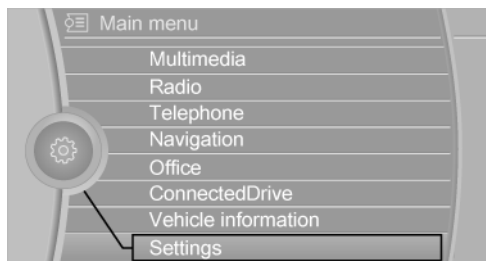

3. If necessary, tilt the Controller to the left to display "Time/date".
4. Turn the Controller until "Time/date" is highlighted and press the Controller.



- Turn the Controller until "Time:" is highlighted and press the Controller.

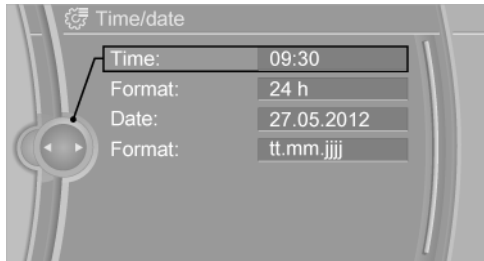

- Turn the Controller to set the hour and press the Controller.
- Turn the Controller to set the minutes and press the Controller.

## Status information

### Status field

The following items of information are displayed in the status field on the top right:

- ▶ Time.
- ▶ Current entertainment source.
- ▶ Sound output on/off.
- ▶ Reception level of mobile telephone network.
- ▶ Phone status.
- ▶ Reception of traffic reports.

### Symbols in the status field

The symbols are combined in the following groups.

### Symbols for radio

Symbol	Meaning
TP	Traffic Information switched on.

## Symbols for telephone

Symbol	Meaning
	Incoming or outgoing call.
	Missed call.
	Reception level of mobile telephone network. Symbol flashes: network search.
	No mobile telephone network available.
	Bluetooth switched on.
	Data transfer active.
	Roaming active.
	Text message received.
	SIM card check.
	SIM card disabled.
	SIM card not found.
	PIN required.

## Symbols for entertainment

Symbol	Meaning
	CD/DVD player.
	Music collection.
	Gracenote® database.
	AUX-IN port.
	USB audio interface.
	Mobile telephone audio interface.

## Other functions

Symbol	Meaning
	Spoken instructions switched off.

## Split-screen

### General

In the split-screen view, additional information can be displayed on the right-hand side of the screen, for example information from the on-board computer.

This information remains visible in the split-screen view even if a switch is made to another menu.

### Switching the split-screen view on and off

On the Control Display:

-  Press the button.
- "Split screen"

### Selecting display

On the Control Display:

-  Press the button.
- "Split screen"
- Tilt the Controller until the split-screen is selected.
- Press the Controller or select "Split screen content"
- Select the desired menu item.

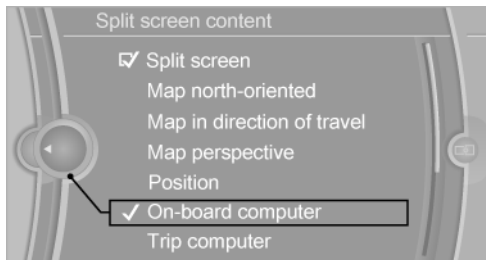

## Favourites buttons

### General

iDrive functions can be saved on the favourites buttons and called up directly, for example radio stations, navigation destinations, telephone numbers and shortcuts into the menu.

The settings are saved for the current profile.

### Without navigation system and telephone

On the buttons, only the radio transmitter can be saved.

### Saving a function

- Highlight the function using the iDrive.
-  Press and hold the required button until a signal sounds.

### Performing a function

-  Press the button.
- The function is carried out immediately. If you have selected a telephone number, for example, the connection will also be established.

### Displaying assignment of buttons

Touch the buttons with your finger. Do not wear gloves or use objects.

The assignment of the buttons is displayed at the top edge of the screen.

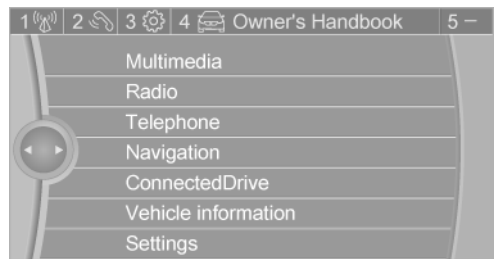

## Clearing assignment of buttons

1. Press buttons 1 and 8 simultaneously for approximately five seconds.
2. "OK"

## Deleting personal data in vehicle

### Principle

Vehicle stores personal data, depending on how it is used, such as stored radio stations. This personal data can be permanently deleted using iDrive.

### General

Following data can be deleted, depending on equipment:

- ▶ Personal Profile settings.
- ▶ Stored radio stations.
- ▶ Stored favourite buttons.
- ▶ Trip and on-board computer values.
- ▶ Music collection.
- ▶ Navigation, for example stored destinations.
- ▶ Phone book.
- ▶ Online data, for example favourites, cookies.
- ▶ Voice memos.
- ▶ Login accounts.
- ▶ RemoteApp smartphone pairing.

It can take up to 30 minutes in total to delete data.

### Operating requirements

Data can only be deleted at a standstill.

## Deleting data

Follow the instructions on the Control Display.

1. Switch on ignition.
2. "Settings"
3. Calling up "Options".
4. "Delete personal data"
5. "Continue"
6. "OK"

## Entering letters and digits

### General

On the Control Display:

1. Turn Controller and select letters or digits.
2. If applicable, select other letters or digits.
3. Select "OK" to confirm the input.

Symbol	Function
	Press the Controller: deletes a letter or digit.
	Press and hold down the Controller: deletes all numbers or letters.

### Change between upper/lower case, numbers and symbols

Depending on the menu, you can switch between the input of lower case or upper case letters, numbers and symbols:

Symbol	Function
<b>A<sup>B</sup>C</b>	Enter letters.
1@+	Enter digits.
abc or ABC	Tilt the Controller up.

### Without navigation system

@<sup>A</sup> A<sup>a</sup> a<sup>@</sup> Select the symbol.

## Entry comparison

Input of names and addresses: the selection is gradually narrowed down and possibly supplemented with every subsequent letter that you enter.

Inputs are continuously compared with the data saved in the vehicle.

- ▶ Only letters that are present in the data is offered for entry.
- ▶ Destination search: place names can be entered in the writing of any language available on the Control Display.

# Voice control system

## Vehicle equipment

This chapter describes all standard, national and special equipment provided in the model series. Equipment not available in the vehicle is therefore also described, for example the selected special equipment or national version. This also applies to safety-relevant functions and systems. Comply with the relevant national regulations when using the corresponding functions and systems.

## Principle

- ▶ Through the voice control system most functions shown in the Control Display can be operated by spoken commands. The system supports spoken input.
- ▶ Functions that can only be used when the vehicle is stationary cannot be operated via the voice control system.
- ▶ The system has a special microphone on the driver's side.
- ▶ ›...‹ Indicates commands for the voice control system in the Owner's Handbook.

## Requirements

On the control display set a language that is also supported by the voice control system, so that the vehicle can identify spoken commands.

Setting the language, see page 94.

## Issuing voice commands

### Activating the voice control system

1.  Press the button on the steering wheel.
2. Wait for acoustic signal.
3. Issue the command.

Command detected by voice control system is announced and displayed in instrument cluster.

 Symbol in the instrument cluster indicates that the voice control system is active.

If no further spoken commands are possible, switch to iDrive to control the function in this case.

### Switching off the voice control system

 Press the button on the steering wheel or say ›Cancel‹.

## Possible commands

Most of the menu items on the Control Display can be called up using spoken commands.

The possible commands depend on which menu is currently displayed on the Control Display.

For various functions there are short commands.

Several list entries, for example telephone book entries, can also be selected using the voice control system. When doing this, list entries are to be spoken exactly as they are shown in the relevant list.

### Having possible commands read aloud

Possible commands can be read aloud: ›Voice commands‹.

If, for example, the menu "Settings" is displayed, the commands for the settings are announced.

### Running functions using short commands

Main menu functions can be performed immediately using short commands, almost irrespective of which menu item is selected, for example ›Vehicle status‹.

### Help dialogue to voice control system

Call up help dialogue: ›Help‹.

Further commands for help dialogue:

- ▷ ›Help with examples: information on the current possible operations and the most important commands for this are read out.
- ▷ ›Help with voice input: information on the operating principle of the voice control system is read out.

## An example: call up sound settings

### Using main menu

Commands on the menu are read out so they can also be selected using the controller.

1. If necessary, switch on entertainment audio output.
2.  Press the button on the steering wheel.
3. ›Radio‹
4. ›Sound‹

### Through short command

Desired sound setting can also be started using a shortcut.

1. If necessary, switch on entertainment audio output.

2.  Press the button on the steering wheel.
3. ›Sound‹

## Setting the speech dialogue

You can set whether the system uses the standard dialogue or the short variant,

With the short variants of the speech dialogue, the system announcements are played in shortened form.

1. "Settings"
2. "Language/units"
3. "Voice contr.."
4. Select the setting.

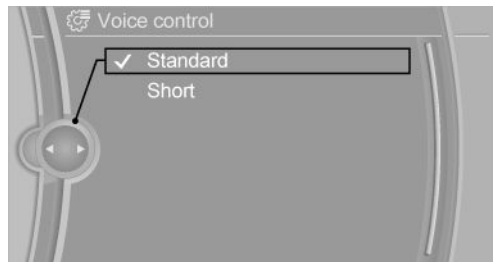

## Adjusting volume

Turn the volume knob during the voice instructions until the desired volume is obtained.

- ▷ The volume is retained even if you change the volume of other audio sources.
- ▷ The volume is stored for the currently used profile.

## Information regarding emergency calls

The voice control system should not be used for emergency calls. Under stress, the spoken language and voice pitch can change, which

could unnecessarily delay the connection of your call.

Instead, use the SOS button, see page 202, in the area of the interior mirror.

## Operating conditions

- ▷ Commands, digits and letters should be pronounced fluently, with the usual emphasis, and at a normal volume and speed.
- ▷ Always speak the commands in the language of the voice control system.
- ▷ When selecting the radio station, use the customary pronunciation of the station name as it is displayed on the Control Display.
  - ▷Station ..., for example, Classic Radio station.
- ▷ Doors, windows and the Glass Roof should be kept closed to avoid noise interference.
- ▷ Avoid background noises in the vehicle while you are speaking.

# Integrated Owner's Handbook in the vehicle

## Vehicle equipment

This chapter describes all standard, national and special equipment provided in the model series. Equipment not available in the vehicle is therefore also described, for example the selected special equipment or national version. This also applies to safety-relevant functions and systems. Comply with the relevant national regulations when using the corresponding functions and systems.

## Integrated Owner's Handbook in the vehicle

The integrated Owner's Handbook can be shown in the control display. It particularly describes the equipment and functions present in the vehicle.

### Components of the integrated Owner's Handbook

The integrated Owner's Handbook consists of three parts, which provide various levels of information or access possibilities.

#### Quick Reference

Important information is found in the quick reference for the operation of the vehicle, the operation of fundamental vehicle functions or in case of breakdown. This information can also be displayed when driving.

#### Search by pictures

Using the search by pictures, information and descriptions can be searched using pictures. For example, this is particularly helpful when the description of a piece of equipment is needed, which cannot be named.

## Owner's Handbook

Here, information and descriptions can be searched via the index by directly entering a search term.

### Selecting components

1.  Press the button.
2. Turn the Controller and select "Vehicle information".
3. Press the Controller.
4. Select desired area:
  - ▷ "Quick reference"
  - ▷ "Picture search"
  - ▷ "Owner's Handbook"

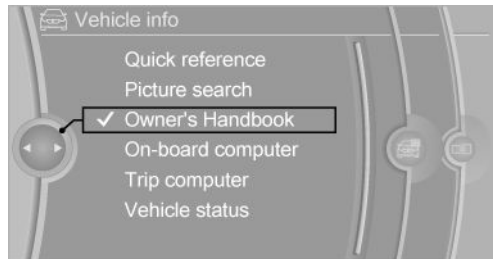

### Browsing within the Owner's Handbook

#### Page by page with link access

Turn the controller until the next or previous page is displayed.

#### Page by page without link access

Browse the pages directly, skipping links.

Highlight the symbol once. Then simply press the controller to browse from page to page.



Browse back.



Browse forward.

## Context-sensitive help - Owner's Handbook for the currently selected function

Suitable information can be displayed directly.

### Calling up with iDrive operation

Switch to the Options menu directly from the application on the Control Display:

1.  Press the button or tilt the Controller repeatedly to the right until the "Options" menu appears.
2. "Show Owner's Handbook"

### Calling up with display of a check control message

Directly from the check control message on the Control Display:

"Show Owner's Handbook"

### Switching between function and Owner's Handbook

You can use the Control Display to switch from a function, for example radio, to the Owner's Handbook, and then back and forth between the two displays:

1.  Press the button or tilt the Controller repeatedly to the right until the "Options" menu appears.
2. "Show Owner's Handbook"
3. Select the desired page in the Owner's Handbook.

4.  Press the button again to switch back to the last displayed function.

5.  Press the button again to switch back to the last displayed page of the Owner's Handbook.

To switch continuously between the last displayed function and the last displayed page of the Owner's Handbook, repeat steps 4 and 5. As you do so, new screens are opened.

### Favourites buttons

#### General

The Owner's Handbook can be stored in the favourite buttons and called up directly.

#### Saving

1. Select "Owner's Handbook" using the iDrive.
2.  Press the desired button for longer than two seconds.

#### Use

1.  Press the button. The Owner's Handbook is displayed immediately.



## Controls

This chapter enables you to operate your car with greater ease, explaining in detail the features designed to make your journey safer, more comfortable and more enjoyable.

# Opening and closing

## Vehicle equipment

This chapter describes all standard, national and special equipment provided in the model series. Equipment not available in the vehicle is therefore also described, for example the selected special equipment or national version. This also applies to safety-relevant functions and systems. Comply with the relevant national regulations when using the corresponding functions and systems.

## Remote control/keys

### General

The delivery specification includes two remote controls with integrated keys.

Every remote control contains a replaceable battery.

The functions of buttons may be set depending on equipment and national version. Settings, see page 41.

For each remote control, personal settings are stored in the vehicle. Personal profile, see page 33.

Further information on servicing is also stored in the remote controls Service data in the remote control, see page 191

### Overview

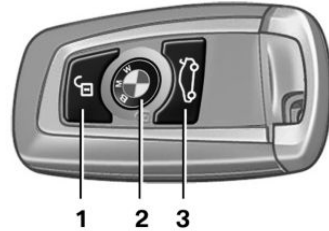

- 1 Unlocking
- 2 Locking
- 3 Opening the tailgate

### Integrated key

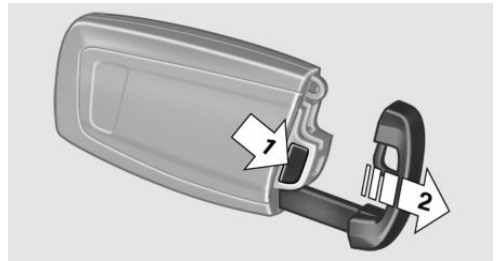

Press button, arrow 1, and pull out key, arrow 2.

The integrated key fits the following locks:

- ▷ Driver's door.
- ▷ Glove box on the passenger side.

## Replacing the battery

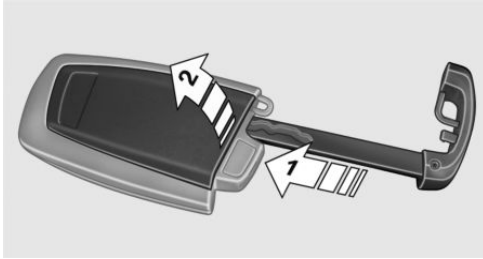

1. Remove the integrated key from the remote control.
2. Push in catch with the key, arrow 1.
3. Remove the cover for the battery compartment, arrow 2.
4. Insert a new battery of the same type with the positive side facing upwards.
5. Press the cover back into position.



Dispose of old batteries at a Service Partner or a qualified specialist workshop or hand them into an authorised collecting point.

## New remote controls

New remote controls are available from a Service Partner or a qualified specialist workshop.

## Loss of remote controls

A lost remote control can be blocked by a Service Partner or a qualified specialist workshop.

## Special ID of the remote control

The ignition can be switched on or the engine started even in one of the following situations:

- ▷ Interference in the radio transmission to the remote control from external sources, for example by radio masts.
- ▷ Flat battery in the remote control.
- ▷ Fault in radio transmission due to mobile radio device in the immediate vicinity of the remote control.

- ▷ Fault in radio transmission due to the charger when charging in the vehicle, for example for mobile devices.

If an attempt is made to switch on the ignition or start the engine, a Check Control message is displayed.

## Starting engine with special ID of remote control

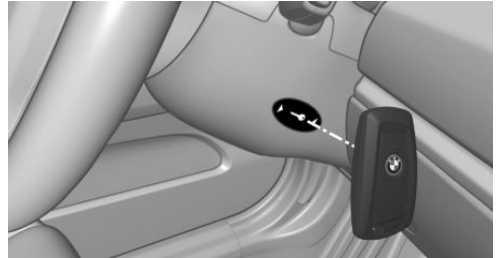

M double clutch transmission: with the relevant Check Control message, hold the remote control, as illustrated, to the mark on the steering column and press the start/stop button within 10 seconds with the brake depressed.

Manual gearbox: with the relevant Check Control message, hold the remote control, as illustrated, to the mark on the steering column and press the start/stop button within 10 seconds with the clutch depressed.

If the remote control is not detected: change the height of the remote control slightly and repeat the procedure.

## Personal Profile

### Principle

Personal profile provides three profiles in which personal vehicle settings can be saved. Each remote control is allocated to one of these profiles.

When the vehicle is unlocked with a remote control, the allocated personal profile is activated. All the settings saved in the profile are made automatically.

If several drivers each use their own remote control, the vehicle will adapt to their personal settings when it is unlocked. These settings are also resaved if the vehicle is used in the intervening period by someone with a different remote control.

Changes to settings are saved automatically in the personal profile.

Three personal profiles and a guest profile can be created.

## Settings

Settings for the following systems and functions are saved in the active profile. The extent of settings that can be saved depends on the country and equipment.

- ▷ Unlocking and locking.
- ▷ Light.
- ▷ Air conditioning.
- ▷ Radio.
- ▷ Instrument cluster.
- ▷ Favourites buttons.
- ▷ Volumes, sound.
- ▷ Control Display.
- ▷ Navigation.
- ▷ TV.
- ▷ Park Distance Control PDC.
- ▷ Rear-view camera.
- ▷ Side view.
- ▷ Head-Up Display.
- ▷ M Drive: configurations.
- ▷ Driver's seat position, exterior mirror position, steering wheel position.
- ▷ Cruise Control.
- ▷ Intelligent Safety.
- ▷ Lane change warning.

## Profile management

### Calling up profiles

Independently of the remote control that is used, another profile can be called up.

Via iDrive:

1. "Settings"
2. "Profiles"
3. Select a profile.
  - ▷ The settings saved in the called-up profile are made automatically.
  - ▷ The profile called up is assigned to the remote control currently used.
  - ▷ If the profile has already been allocated to another remote control, this profile applies to both remote controls. It is no longer possible to differentiate between the settings of both remote controls.

### Renaming profiles

To avoid mixing up the profiles, each profile can be given a personal name.

On the Control Display:

1. "Settings"
2. "Profiles"
3. Call up "Options".
4. "Rename current profile"

### Resetting profiles

Settings of the active profile are reset to factory settings.

On the Control Display:

1. "Settings"
2. "Profiles"
3. Call up "Options".
4. "Reset current profile"

### Exporting profiles

Most of the settings of the active profile can be exported.

This may be useful for securing and calling up personal settings, for example, before taking the vehicle into a Service Centre. The saved profiles can be taken to another vehicle with the Personal Profile function.

The following options are available for export:

- ▷ Via BMW Online.
- ▷ Via USB interface to a USB medium.  
Common file systems for USB media are supported. FAT32 and exFAT formats are recommended for exporting profiles, export might not be possible with other formats.

On the Control Display:

1. "Settings"
2. "Profiles"
3. "Export profile"
4. BMW Online: "BMW Online"  
USB interface: "USB device"

### Importing profiles

Profiles exported via BMW Online can be imported via BMW Online.

Profiles saved on a USB medium can be imported using the USB interface.

Existing settings are overwritten with the imported profile.

On the Control Display:

1. "Settings"
2. "Profiles"
3. "Import profile"
4. BMW Online: "BMW Online"  
USB interface: "USB device"

### Using a guest profile

With the guest profile, individual settings can be made which are not saved in any of the three personal profiles.

This can be beneficial if a driver without their own profile uses the vehicle temporarily.

On the Control Display:

1. "Settings"
2. "Profiles"
3. "Guest"

Note: the guest profile cannot be renamed. It is not allocated to the current remote control.

### Showing profile list at start

The profile list can be shown at the start to select the desired profile.

On the Control Display:

1. "Settings"
2. "Profiles"
3. Call up "Options".
4. "Profile list at start"

## With the remote control

### Note



#### WARNING

Persons remaining in the vehicle or pets left inside can lock the doors from the inside and lock themselves in. The vehicle cannot be opened from the outside. Danger of injury. Carry the remote control with you so that you can open the vehicle from the outside. ◀

### Unlocking



Press the button on the remote control.

Depending on the settings, see page 41, the following entrances are unlocked.

- ▷ The driver door and the fuel filler flap.
- ▷ All doors, the boot lid and the fuel filler flap.

The following functions are also carried out:

- ▷ The interior light is switched on. At dark, the courtesy light is additionally switched

on. This function is not available if the interior light was switched off manually.

- ▷ The welcome light is switched on if this function was activated.
- ▷ Exterior mirrors folded in using comfort closing are folded out.
- ▷ Anti-theft system is switched off.
- ▷ The alarm system, see page 42, is disarmed.



Press the button on the remote control twice in direct succession.

When a door is opened, the window is lowered further to make it easier to get in. This function must be activated in the settings, see page 41.

## Comfort opening



Keep the button on the remote control pressed after unlocking.

The windows and Glass Roof are opened for as long as the button on the remote control is pressed.

## Locking



### WARNING

If the vehicle is locked from the outside, it cannot be unlocked from the inside in some country versions.

If persons must remain in the vehicle for an extended period of time and are exposed to extreme heat or cold, there is a risk of injury or life. Do not lock the vehicle from the outside when there is someone inside it. ◀

The driver's door must be closed.



Press the button on the remote control.

All doors, boot lid and fuel filler flap are locked.

Anti-theft system is switched on. It prevents the doors from being able to be unlocked using the locking buttons or the door openers.

The alarm system, see page 42, is armed.

## Comfort closing



Keep the button on the remote control pressed after locking.

The windows and the Glass Roof are closed for as long as the button on the remote control is pressed.

Exterior mirrors are folded in.



### WARNING

Body parts can be trapped during comfort closing. Danger of injury. During comfort closing, make sure that the area of movement is free. ◀

## Switching on interior light and courtesy light



With the vehicle locked, press the button on the remote control.

The courtesy light is only switched on at dark. This function is not available if the interior light was switched off manually.

If the button is pressed again within 10 seconds of locking, passenger compartment protection and tilt alarm sensor of alarm system, see page 43, are switched off. After locking, wait 10 seconds before pressing the button again.

## Opening boot lid



Press the button on the remote control for approximately one second.

The boot lid opens, regardless of whether the vehicle was locked or unlocked.

The boot lids swings rearwards and upwards when opened. Make sure that there is sufficient space.

Depending on the equipment and country version it can be set whether the doors are also locked. Adjust the settings, see page 41.

In some equipment versions, doors are also unlocked if appropriate

To prevent the remote control from being locked in, do not place the remote control in the boot.

If the doors were not unlocked, the boot lid is locked again as soon as it is closed.

## Malfunction

Detection of the remote control by the vehicle may be disrupted by the following circumstances, amongst others:

- ▷ The battery of the remote control is discharged. Replacing the battery, see page 33.
- ▷ Disruption of the radio link by transmission masts or other equipment transmitting powerful signals.
- ▷ Shielding of the remote control by metallic objects.
- ▷ Disruption of the radio link by mobile telephones or other electronic devices in the immediate vicinity.

Do not transport the remote control together with metallic objects or electronic devices.

If there is a malfunction, the vehicle can also be unlocked and locked from the outside without remote control, see page 37.

## Without remote control

### From outside



#### WARNING

If the vehicle is locked from the outside, it cannot be unlocked from the inside in some country versions.

If persons must remain in the vehicle for an extended period of time and are exposed to extreme heat or cold, there is a risk of injury or life. Do not lock the vehicle from the outside when there is someone inside it. ◀



#### ATTENTION

The door lock is firmly connected to the door. The door handle can be moved. Pulling the door handle when the integrated key is inserted can damage the paint or the key. Danger of damage to property. Pull out the integrated key before pulling on the outer door handle. ◀

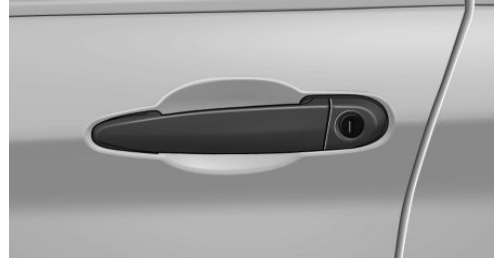

Unlock or lock the driver's door using the integrated key, see page 32, in the door lock. The other doors must be unlocked or locked from the inside.

## Alarm system

The alarm system is not armed if the vehicle is locked with the integrated key.

Alarm system is triggered if the vehicle has been unlocked using the door lock.

To end this alarm, unlock the vehicle with the remote control or turn on the ignition, with special ID of the remote control, see page 33, as necessary.

## From inside

### Unlocking and locking



Press button for central locking to lock or unlock vehicle when doors are closed.

Locking does not activate anti-theft protection for vehicle.

The fuel filler flap remains unlocked.

In the event of an accident of sufficient severity, the vehicle is automatically unlocked. The hazard warning lights and interior lights illuminate.

### Unlocking and opening



- ▷ Press button for central locking to unlock doors together and then pull door opener above armrest.
- ▷ Pull twice on door opener on door to be opened: first pull unlocks door, second pull opens door. The other doors remain locked.

## Boot lid

### Notes

To prevent the remote control from being locked in, do not place the remote control in the boot.

### Opening

The tailgate swings rearwards and upwards when opened.

Make sure that there is sufficient clearance.

### Opening from outside

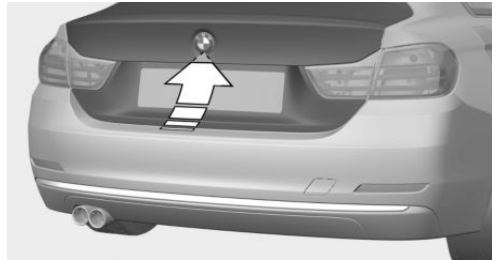

- ▷ Press the button on the tailgate.
- ▷  Press the button on the remote control for approximately one second.

Doors are also unlocked if appropriate. Unlocking with remote control, see page 36.

The tailgate opens.

### Closing

### Notes

 **WARNING**  
Operating the boot lid can lead to parts of the body becoming trapped. Danger of injury. When opening and closing, make sure that the area of movement of the boot lid is free. ◀

To prevent the remote control from being locked in, do not place the remote control in the boot.

## Closing



The recessed handles in the boot lid lining make it easier to pull the boot lid down.

## Emergency release



Pull the handle in the boot.  
This will unlock the boot lid.

## Comfort Access

### Principle

Access to the vehicle is possible without activating the remote control.

It is sufficient to have the remote control with you, for example in a trouser pocket.

The vehicle automatically recognises the remote control when it is in the immediate vicinity or the interior of the vehicle.

Comfort Access supports the following functions:

- ▷ Unlocking/locking the vehicle.
- ▷ Comfort closing.

- ▷ Opening the boot lid separately.
- ▷ Open boot lid contactlessly.
- ▷ Start the engine.

### Notes

To prevent the remote control from being locked in, do not place the remote control in the boot.

### Functional requirements

- ▷ No external sources of interference in the vicinity.
- ▷ To lock, the remote control must be located outside the vehicle in the area of the doors.
- ▷ Approximately 2 seconds need to elapse before the vehicle can be unlocked and locked again.
- ▷ An engine start is only possible if the remote control is in the vehicle.

### Unlocking

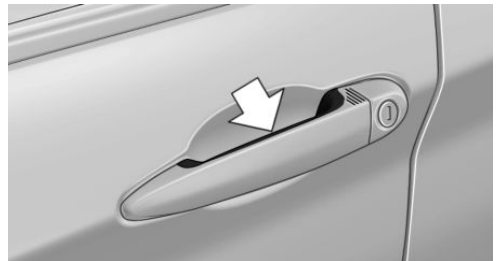

Firmly grab the handle on the driver's or front passenger's door, arrow.

This corresponds to pressing the  button on the remote control.

## Locking

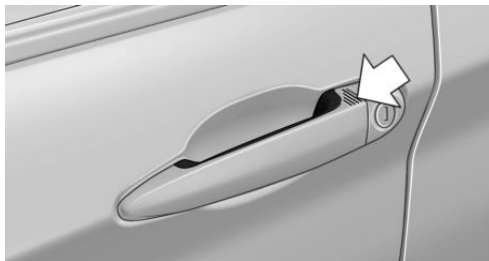

Use your finger to touch area on door handle of driver's or front passenger's door for approximately 1 second, without gripping door handle.

This corresponds to pressing the  button on the remote control.

To reduce the burden on the vehicle battery, make sure that the ignition and all electrical consumers are switched off prior to locking.

## Comfort closing



### WARNING

Body parts can be trapped during comfort closing. Danger of injury. During comfort closing, make sure that the area of movement is free. ◀

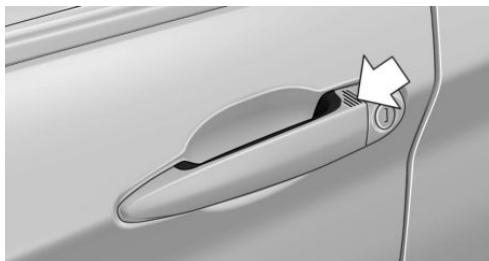

Use your finger to touch area on door handle of driver's or front passenger's door and keep your finger there without gripping door handle.

This corresponds to pressing and holding  button of remote control.

In addition to locking, windows and Glass Roof are closed and exterior mirrors are folded in.

## Opening boot lid individually

Press the button on the outside of the boot lid.

This corresponds to pressing  button on remote control.

Status of doors does not change.

## Contactless opening of the boot lid

### General

The boot lid can be opened contactlessly if you carry the remote control. Two sensors detect a foot movement forwards in the rear area and the boot lid opens.

### Foot movement to be undertaken



### WARNING

During operation without contact, there is a risk of touching vehicle parts, for example the hot exhaust system. Danger of injury. Make sure you are standing securely when you perform the foot movement, and do not touch the vehicle. ◀

1. Stand in the centre behind the vehicle, approximately an arm's length away from the rear of the vehicle.
2. A foot must move as far as possible under the vehicle in the direction of travel and be withdrawn again immediately. In this movement, the leg must pass through the range of both sensors.

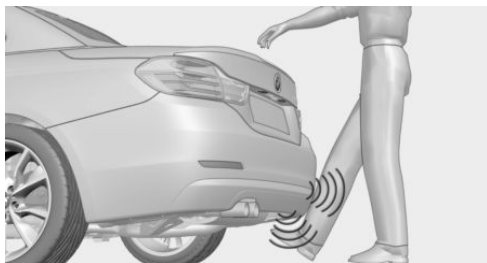

## Opening

Perform the foot movement described previously.

The boot lid opens, regardless of whether it was locked or unlocked.

The hazard warning lights flash before opening.

If the remote control is within the sensor range, the boot lid can be accidentally opened by an unintentional or supposedly recognized foot movement.

The sensor range extends to approx. 1.50 m, 5 ft behind the rear area.



#### WARNING

Operating the boot lid can lead to parts of the body becoming trapped. Danger of injury. When opening and closing, make sure that the area of movement of the boot lid is free. ◀



#### ATTENTION

The boot lid swings rearwards and upwards when opened. Danger of damage to property. When opening and closing, make sure that the area of movement of the boot lid is free. ◀

## Malfunction

Detection of the remote control by the vehicle may be disrupted by the following circumstances, amongst others:

- ▶ The battery of the remote control is discharged. Replacing the battery, see page 33.
- ▶ Disruption of the radio link by transmission masts or other equipment transmitting powerful signals.
- ▶ Shielding of the remote control by metallic objects.
- ▶ Disruption of the radio link by mobile telephones or other electronic devices in the immediate vicinity.

Do not transport the remote control together with metallic objects or electronic devices.

In case of a fault, unlock and lock the vehicle with the buttons on the remote control or with the integrated key, see page 37.

## Settings

### Unlocking

Settings are saved in active profile, see page 33.

### Doors

1. "Settings"
2. "Doors/key"
3.  Select the symbol.
4. Select the desired function:
  - ▶ "Driver's door only"
 

Only the driver's door and fuel filler flap are unlocked. Pressing again unlocks the entire vehicle.
  - ▶ "All doors"
 

The entire vehicle is unlocked.
  - ▶ "Comfort entry"
 

The entire vehicle is unlocked.

Pressing the button on the remote control twice in direct succession causes the window to be lowered further when the door is subsequently opened.

### Boot lid

Depending on the equipment and country version, these settings are not provided.

1. "Settings"
2. "Doors/key"
3.  Select the symbol.
4. Select the desired function:
  - ▶ "Tailgate"
 

Boot lid is opened.
  - ▶ "Tailgate + door(s)"

Boot lid is opened and doors are unlocked.

## Acknowledgement signal of the vehicle

Settings are saved in active profile, see page 33.

1. "Settings"
2. "Doors/key"
3. "Turn signals for lock/unl."

## Automatic locking

Settings are saved in active profile, see page 33.

1. "Settings"
2. "Doors/key"
3. Select the desired function:
  - ▷ "Automatic relock"
 

The vehicle is locked automatically after a short while if no door is opened.
  - ▷ "Lock after driving away"
 

On driving off, the vehicle is locked automatically.

## Calling up seat, mirror setting

The last adjusted driver's seat and exterior mirror position is saved for the currently used remote control.

When the vehicle is unlocked, this position is called up automatically if the function has been enabled.

### WARNING

Danger of trapping when moving the seats. Danger of injury or damage to property. Before making the setting, make sure that the movement area of the seat is clear. ◀

Adjustment procedure is interrupted:

- ▷ By operating the switch or the seat adjustment.

- ▷ By touching a button of the seat and mirror memory.

## Enabling setting

1. "Settings"
2. "Doors/key"
3. "Last seat position autom."

## Alarm system

### Principle

The alarm system is triggered when the vehicle is locked if:

- ▷ A door, the bonnet or the the boot lid is opened.
- ▷ Movements in the interior.
- ▷ The vehicle's incline changes, for instance if an attempt is made to jack it up and steal the wheels or to raise it prior to towing away.
- ▷ There is an interruption in the power supply from the battery.

The alarm system will respond briefly to unauthorised attempts to access the vehicle as follows:

- ▷ Acoustic alarm.
- ▷ Switching on the hazard warning lights.

### Arming and disarming

At the same time as unlocking and locking the vehicle by remote control or Comfort Access the alarm system is also disarmed or armed.

### Door lock with alarm system armed

Alarm system is deactivated if the vehicle is unlocked using the door lock.

### Boot lid with alarm system armed

The boot lid can be opened even with the alarm system armed.

On closing the boot lid, it is locked again and monitored, as long as the doors are locked. The hazard warning system flashes once.

### Indicator light on the rear-view mirror

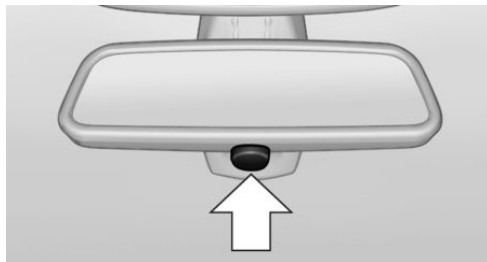

- ▷ Indicator light flashes every 2 seconds:  
The alarm system is armed.
- ▷ Indicator light flashes after locking:  
Doors, bonnet or boot lid are not closed correctly. Correctly closed access points are secured.  
After ten seconds, the indicator light flashes continuously. Interior protection and tilt alarm sensor are not active.  
If the access that is still open is closed then the interior protection and tilt alarm sensor are switched on.
- ▷ The indicator light no longer illuminates after the vehicle has been unlocked:  
No attempt has been made to tamper with the vehicle.
- ▷ The indicator light flashes after unlocking until the ignition is switched on, but for no longer than approximately five minutes:  
The alarm has been triggered.

### Tilt alarm sensor

The incline of the vehicle is monitored. Alarm system responds, for example, when there is an attempt to steal a wheel or when towing away.

### Interior movement detector

To ensure perfect functioning, the windows and Glass Roof must be closed.

### Avoiding false alarms

The tilt alarm sensor and interior movement detector can be switched off together, for example in the following situations:

- ▷ In car washes.
- ▷ In two-level garages.
- ▷ During transport via motorail, car ferry or trailer.
- ▷ When there are animals in the vehicle.

### Switching off the tilt alarm sensor and interior movement detector



Press the button on the remote control again within 10 seconds, as soon as the vehicle is locked.

The indicator light illuminates for approximately 2 seconds and then flashes again.

The tilt alarm sensor and the interior movement detector are switched off until the next time the car is locked.

### Switching off the alarm

- ▷ Unlock the vehicle with the remote control or switch on the ignition, if necessary using special ID of remote control, see page 33.
- ▷ For Comfort Access: completely grasp either front door handle when carrying remote control.

## Power windows

### Note



#### WARNING

Unsupervised children or animals in the vehicle can set the vehicle in motion and endanger themselves or other road users, for example by the following actions:



- ▷ Pressing the start/stop button.
- ▷ Releasing the parking brake.
- ▷ Opening and closing doors or windows.
- ▷ Setting the selector lever to neutral.
- ▷ Operating vehicle equipment.

Risk of accident or injury. Do not leave children or animals unsupervised in the vehicle. When leaving the vehicle, take the remote control with you and lock it. ◀

## Overview



## Opening



- ▷  Push the switch as far as the resistance point.  
The window opens as long as the switch is held.
- ▷  Push the switch past the resistance point.  
The window opens automatically. The movement is stopped by pressing the switch again.

See also: Comfort opening, see page 36, by remote control.

## Closing

 **WARNING**  
Operating the windows can lead to parts of the body or objects becoming trapped. Danger of injury or damage to property. When

opening and closing, make sure that the area of movement of the windows is free. ◀

- ▷  Pull the switch as far as the resistance point.  
The window closes as long as the switch is held.
- ▷  Pull the switch past the resistance point.  
The window closes automatically. Pulling the switch again stops the movement.

See also: Comfort closing, see page 36, by remote control.

See also: closing using Comfort Access, see page 39.

## After switching off the ignition

Windows can still be operated:

- ▷ For some time with radio readiness switched on.
- ▷ For approximately one minute with the ignition switched off.

## Anti-trap mechanism

 **WARNING**  
Operating the windows can lead to parts of the body or objects becoming trapped. Danger of injury or damage to property. When opening and closing, make sure that the area of movement of the windows is free. ◀

 **WARNING**  
Accessories on the windows, for example aerials, can impair the anti-trap mechanism. Danger of injury. Do not attach any accessories in the area of movement of the windows. ◀

If the closing power exceeds a certain value on closing a window, the closing operation is interrupted.

The window opens again slightly.

## Closing without the anti-trap mechanism



### WARNING

Operating the windows can lead to parts of the body or objects becoming trapped. Danger of injury or damage to property. When opening and closing, make sure that the area of movement of the windows is free. ◀

If an external danger or ice does not allow you to close the windows normally, proceed as follows:

1. Pull the switch past the resistance point and hold it there.  
The anti-trap mechanism is restricted and the window opens slightly when the closing force exceeds a certain value.
2. Pull the switch past the resistance point again within approximately four seconds and hold it there.  
The window closes without the anti-trap mechanism.

## Roller sunblinds

### Roller sunblind for rear window

#### General

If the roller sunblinds for the rear window can no longer be moved after a number of operations in immediate succession, the system is blocked for a limited time to prevent overheating. Allow the system to cool down.

The roller sunblind for the rear window cannot be operated in low interior temperatures.

### Retracting or extending the roller sunblind for rear window



Press the button.

## Glass Roof, electrical

### General

The Glass Roof and the sun blind can be operated separately or together with the same switch.



### Notes



### WARNING

Operating the Glass Roof can lead to parts of the body becoming trapped. Danger of injury. When opening and closing, make sure that the area of movement of the Glass Roof is free. ◀



### WARNING

Unsupervised children or animals in the vehicle can set the vehicle in motion and endanger themselves or other road users, for example by the following actions:

- ▷ Pressing the start/stop button.
- ▷ Releasing the parking brake.
- ▷ Opening and closing doors or windows.
- ▷ Setting the selector lever to neutral.
- ▷ Operating vehicle equipment.

Risk of accident or injury. Do not leave children or animals unsupervised in the vehicle. When leaving the vehicle, take the remote control with you and lock it. ◀

## Raising the Glass Roof



Press the top of the switch.

- ▷ The closed Glass Roof is raised.
- ▷ The opened Glass Roof closes to the raised position. The sun blind does not move.

## Opening/closing Glass Roof and sun blind

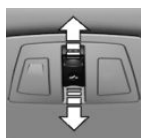

- ▷ Push and hold the switch in the desired direction as far as the resistance point.

The Glass Roof and sun blind open jointly as long as the switch is held.

The Glass Roof closes as long as the switch is held.

The sun blind can be closed by hand.

- ▷ Push the switch beyond the resistance point in the desired direction. Glass Roof and sun blind open automatically. The Glass Roof closes automatically. The sun blind can be closed by hand. Movement is stopped by pressing switch upwards.

Further possibilities:

- ▷ Comfort opening, see page 36, and comfort closing, see page 36, by remote control.
- ▷ Closing using Comfort Access, see page 39.

## Comfort position

If Glass Roof is not completely opened by automatic function, this means comfort position has been reached. In this position, wind noise inside vehicle is at lowest level.

You can continue the movement by subsequently pressing the button.

## After switching off the ignition

The Glass Roof can still be opened or closed for approximately 1 minute after the ignition has been switched off.

## Anti-trap mechanism

If the closing power of the Glass Roof exceeds a certain value, the closing operation is interrupted from approximately the half-open position, or during closing from the raised position.

The Glass Roof opens again slightly.



### WARNING

Operating the Glass Roof can lead to parts of the body becoming trapped. Danger of injury. When opening and closing, make sure that the area of movement of the Glass Roof is free. ◀

## Closing without anti-trap mechanism from open position

In the event of danger from the outside, proceed as follows:

1. Slide the switch forwards beyond the resistance point and hold it there. The anti-trap mechanism is restricted and the Glass Roof opens slightly when the closing force exceeds a certain value.
2. Press the switch forwards once again beyond the resistance point and hold until the Glass Roof closes without the anti-trap mechanism. Ensure that the closing area is clear.

## Closing without anti-trap mechanism from raised position

If there is a danger from the outside slide the switch forwards beyond the resistance point and hold it there.

The Glass Roof closes without the anti-trap mechanism.

## Initialising after power failure

The Glass Roof functions may be restricted after a power cut during the opening or closing operation.

## Initialising the system

The system can be initialised when the vehicle is stationary and the engine is running.

During the initialisation the Glass Roof closes without the anti-trap mechanism.



### WARNING

Operating the Glass Roof can lead to parts of the body becoming trapped. Danger of injury. When opening and closing, make sure that the area of movement of the Glass Roof is free. ◀



Press the top of the switch and hold until the initialisation is complete:

- ▷ Initialisation begins within 15 seconds and is complete when the Glass Roof is fully closed.
- ▷ The Glass Roof closes without the anti-trap mechanism.

# Adjusting

## Vehicle equipment

This chapter describes all standard, national and special equipment provided in the model series. Equipment not available in the vehicle is therefore also described, for example the selected special equipment or national version. This also applies to safety-relevant functions and systems. Comply with the relevant national regulations when using the corresponding functions and systems.

## Safe seated position

A seated position that suitably reflects your requirements is a vital condition of relaxed driving with a minimum of fatigue.

In the event of an accident, the seated position plays an important role together with:

- ▷ Seat belts, see page 52.
- ▷ Head restraints, see page 54.
- ▷ Airbags, see page 104.

## Seats

### Notes

**WARNING**  
Seat adjustment during the journey can lead to unexpected seat movements. You could lose control of the vehicle. Danger of accidents. Only adjust the seat on the driver side when at a standstill. ◀

**WARNING**  
If the seat backrest is angled back too far, the protective effect of the seat belt will no longer be guaranteed. There is a danger of slipping under the seat belt in the event of an accident. Danger of injury or life. Set the seat before starting the journey. Place the seat

backrest in the most upright possible position, and do not change it during the journey. ◀

**WARNING**  
Danger of trapping when moving the seats. Danger of injury or damage to property. Before making the setting, make sure that the movement area of the seat is clear. ◀

## Manually adjustable seats

### Overview

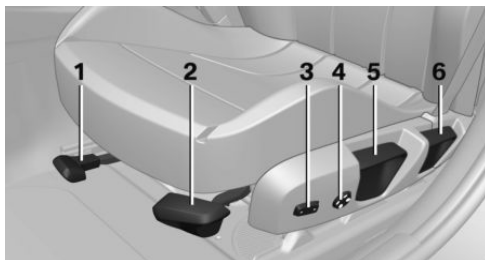

- 1 Forward/back
- 2 Seat angle
- 3 Backrest width
- 4 Lumbar support
- 5 Height
- 6 Backrest angle

## Forward/back

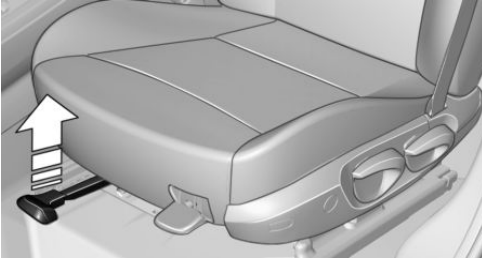

Pull the lever and slide the seat in the desired direction.

After releasing the lever, move the seat gently forward or back to make sure it engages properly.

## Seat angle

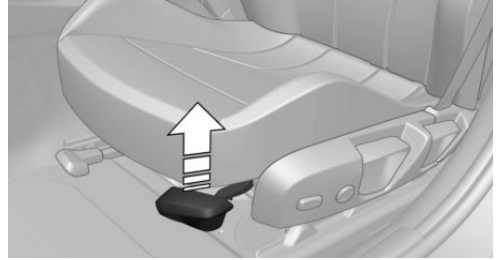

Pull the lever and move the seat until the desired angle is reached. After releasing the lever, sit on and get up out of the seat to make sure it engages properly.

## Height

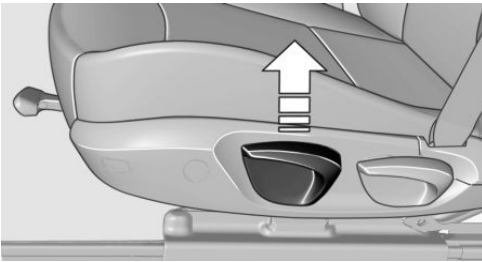

Pull the lever and add or remove pressure on the seat as required.

## Backrest angle



Pull the lever and add or remove pressure on the backrest as required.

## Electrically adjustable seats

### Overview

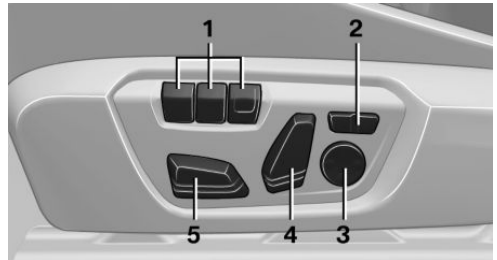

- 1 Seat and mirror memory
- 2 Backrest width
- 3 Lumbar support
- 4 Backrest angle
- 5 Forward/back, height, seat angle

### General

The driver's seat adjustment is saved for the profile currently in use. When the vehicle is unlocked using the remote control, this position is called up automatically if the function, see page 42, for this has been activated.

## Settings in detail

### 1. Longitudinal direction.

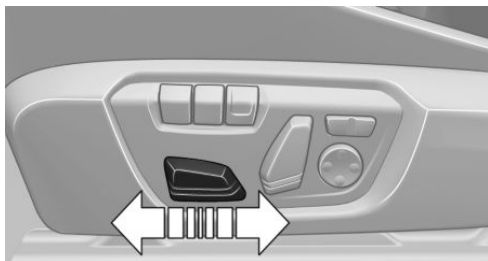

### 2. Height.

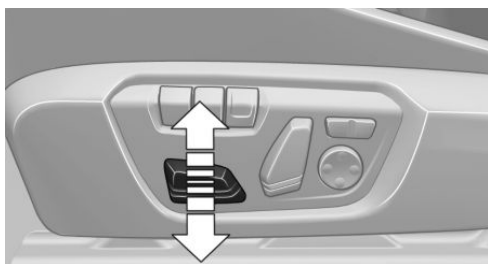

### 3. Seat angle.

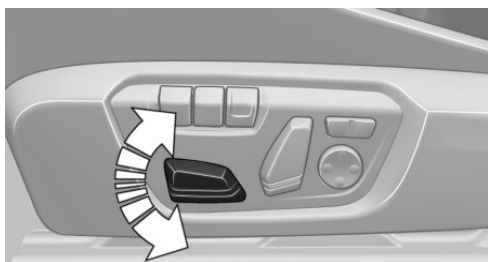

### 4. Backrest angle.

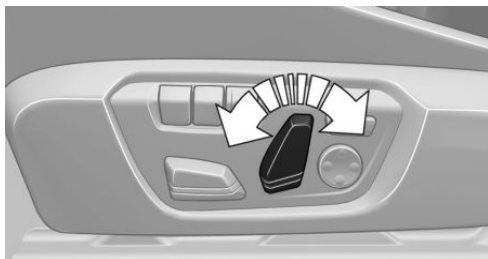

## Lumbar support

The curvature of the backrest can be changed in such a way that the lumbar region, the lordosis, is supported. The upper edge of the pelvis and the spinal column are supported to encourage an upright posture.



- ▶ Press the switch at the front/rear:  
The curvature is increased/decreased.
- ▶ Press the switch at the top/bottom:  
The curvature is shifted upwards/downwards.

## Backrest width



Alter the width of the backrest via the side cushions to adjust the lateral support.

## Seat heating, front



## Switching on



Press the button once per temperature stage.

Maximum temperature is indicated by three LEDs.

If the journey is continued within about 15 minutes, the seat heating automatically activates with the last temperature set.

## Switch off



Press and hold down the button.  
LEDs go out.

## Entering in the back

### Notes



#### WARNING

Danger of trapping when moving the seats. Danger of injury or damage to property. Before making the setting, make sure that the movement area of the seat is clear. ◀



#### WARNING

The backrest can unexpectedly move during the journey when it is unlocked. You could lose control of the vehicle. Danger of injury. Fold back and lock the backrests before every journey. ◀

## Manual longitudinal adjustment

### Comfort entry

The comfort entry contains a memory function for the longitudinal and backrest adjustment.

1. Pull the lever until it stops.

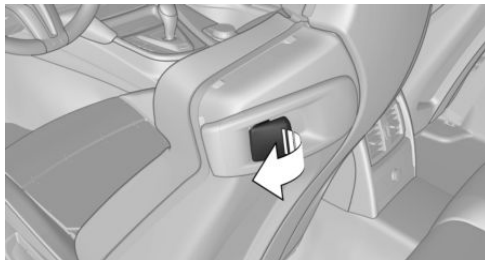

2. Fold the backrest forwards.
3. Slide the seat forwards.

### Original position

1. Push seat back to the starting position.
2. Fold back backrest to lock the seat.



## Electric longitudinal adjustment

### Comfort entry

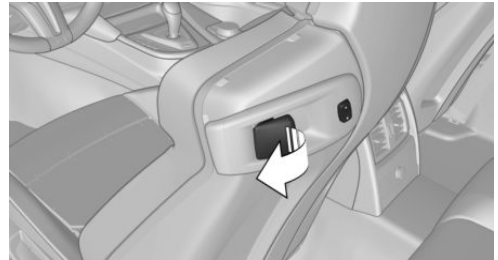

The comfort entry contains a memory function for the longitudinal and backrest adjustment.

1. Pull the lever until it stops.



2. Fold the backrest forwards.
3. Changing the entrance area:
  - ▶  Press and hold down the button until the seat has moved into the desired position. Releasing stops the movement.
  - ▶  Press the button briefly. Seat automatically moves into the end position. Pressing the switch again stops the movement.

### Original position

1. Move seat in original position:
  - ▶  Hold down the button until the seat is moved to its original position. Releasing stops the movement.
  - ▶  Press the button briefly. The seat moves into its original position. Pressing the switch again stops the movement.
2. Fold back backrest.

## Seat belts

### Number of seat belts

Your vehicle has been fitted with four seat belts for the safety of you and your passengers. However, they can only offer protection when adjusted correctly.

### General

Before a journey, always make sure that all occupants have fastened their seat belts.

To protect vehicle occupants, belt interlock is triggered early. When it is applied, guide the belt slowly from the bracket.

The airbags are a complementary safety feature and not a substitute for the seat belts.

The belt anchorage is suitable for adults of any stature as long as the seat is correctly adjusted.

### Notes

#### WARNING

Using a seat belt to restrain more than one person nullifies the protective effect of the seatbelt. Danger of injury or life. Only restrain one person with each seat belt. Do not place infants and children on your lap, but instead restrain them with the child restraint systems provided, and secure them accordingly. ◀

#### WARNING

The protective effect of the seat belts can be restricted or they can be rendered ineffective if put on incorrectly. If a seat belt is not worn correctly, additional injuries can be caused, for example in the event of an accident or braking and evasive manoeuvres. Danger of injury or life. Make sure that all vehicle occupants have fastened their seat belts correctly. ◀

#### WARNING

Seat belts are designed to bear upon the bony structure of the body and should be worn low across the front of the pelvis, or the pelvis, chest and shoulders, as applicable. Wearing the lap section of the belt across the abdominal area must be avoided.

Seat belts should be adjusted as firmly as possible, consistent with comfort, to provide the protection for which they have been designed. A slack belt will greatly reduce the protection afforded to the wearer.

Care should be taken to avoid contamination of the seat belt strap by polishes, oils and chemicals and particularly battery acid. Cleaning may safely be carried out using mild soap and water. The seat belt strap should be replaced if webbing becomes frayed, contaminated or damaged. Seat belts should not be worn with seat belt straps twisted. Each seat belt assembly must only be used by one occupant; it is illegal to carry an infant or a child on the occupant's lap.

It is essential to replace the entire assembly after it has been worn in a severe impact even if damage to the assembly is not obvious. ◀

#### WARNING

No modifications or additions should be made by the user that will either prevent the seat belt adjusting devices from operating to remove slack, or prevent the seat belt assembly from being adjusted to remove slack. ◀

### Correct seat belt use

- ▷ Place the seat belt tightly over the pelvis and shoulder as close as possible to the body and without twisting.
- ▷ Make sure that it is positioned low at the hip in the area of the pelvis. The seat belt must not press on the midriff.
- ▷ The seat belt must not pass across the neck. It should not be pulled or jammed across sharp edges or breakable objects.

- ▷ Avoid bulky clothing.
- ▷ Regularly pull the seat belt in the upper-body area taut.

### Adjustment for automatic retracting seat belts

- ▷ Draw the buckle tongue attached to the seat belt across the body and press it into the buckle catch until a 'click' is heard.
- ▷ Adjustment of the belt length is very important. To adjust the lap belt and check whether the buckle has locked correctly, pull upwards on the shoulder strap until the lap belt fits tightly.
- ▷ The length of the diagonal shoulder strap adjusts itself automatically to allow freedom of movement.
- ▷ To release the seat belt, press the button on the buckle catch unit.

### Fastening the seat belt

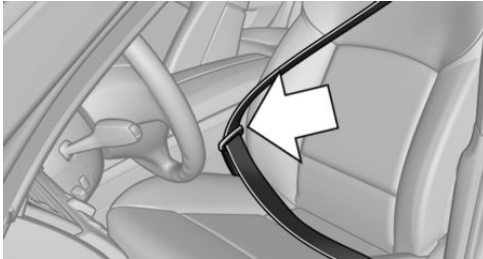

The seat belt buckle must be heard to engage.

### Automatically tension seat belt

If the belt is fastened, the belt strap is automatically fastened once when driving off.

### Unfastening the seat belt

1. Hold onto the belt.
2. Press the red button on the belt buckle.
3. Guide the belt back up to the reel mechanism.

### Seat belt reminder for driver's and front seat passenger seat



A Check Control message is displayed. Check whether the seat belt has been fastened correctly.

The seat belt reminder is activated when the seat belt on the driver's side is not fastened. On some national versions, the seat belt reminder is also activated above approximately 10 km/h, 6 mph if the front passenger's seat belt is not fastened and if heavy objects are located on the seat.

### Not for Australia/New Zealand: Seat belt reminder for rear seats



The indicator light in the instrument cluster is illuminated after the engine starts.

- ▷ Green: seat belt fastened on the corresponding rear seat.
- ▷ Red: seat belt not fastened on the corresponding rear seat.

The seat belt reminder will also be activated if a rear seat belt is unfastened during the journey.

### Damaged seat belts



#### WARNING

The protective effect of the seat belts can be restricted or nullified in the following situations:

- ▷ Belts are damaged, contaminated or have been modified in another way.
- ▷ Belt buckle is damaged or heavily contaminated.
- ▷ Belt tensioners or belt retractors have been modified.

Seat belts can be damaged in an accident without the damage necessarily being apparent. Danger of injury or life. Do not modify seat belts, belt buckles, belt tensioners, belt retractors and belt anchor points; also, keep them

clean. After an accident, have the seat belts inspected at a Service Partner or a qualified specialist workshop. ◀

In the event of stress due to an accident or damage:

Replace the belt system, including the seat belt tensioner, and have the belt anchorage checked.

### Belt holder

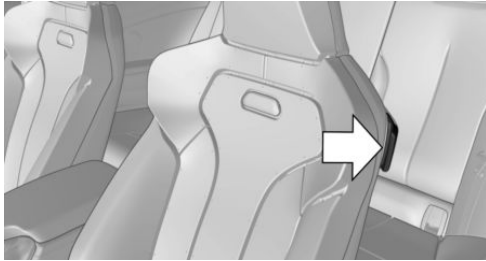

Place the seat belt in the belt holder to make it easier to put on the belt when the seat is moved forwards.

## Head restraints

### Note

**WARNING**

Objects on the head restraint reduce the protective effect in the head and neck area. Danger of injury.

- ▷ Do not fit any covers on the seats or head restraints.
- ▷ Do not hang objects such as coat hangers directly on the head restraint.
- ▷ Only use accessories that have been classified as suitable by the vehicle manufacturer.
- ▷ Do not use any accessories, for example cushions, during the journey. ◀

### Distance

The spacing is adjusted to the back of the head using the incline of the seat backrest.

Adjust the spacing so that the head restraint is as close as possible to the back of the head.

### Removing

The head restraints cannot be removed.

## Seat and mirror memory

### Notes

**WARNING**

Using the memory function during the journey can lead to unexpected seat movements. You could lose control of the vehicle. Danger of accidents. Only call up the memory function at a standstill ◀

**WARNING**

Danger of trapping when moving the seats. Danger of injury or damage to property. Before making the setting, make sure that the movement area of the seat is clear. ◀

### Principle

Two different positions for driver's seat and exterior mirrors can be saved and recalled per profile. Settings for backrest width and lumbar support are not saved.

### Overview



## Saving

1. Switch on ignition.
2. Set desired position.
3. Press  button briefly. LED in button is illuminated.
4. Press the desired button 1 or 2 while the LED is lit. LED turns off.

If SET button was pressed inadvertently:

 Press the button again.  
LED turns off.

## Recalling

### General

There are two possibilities of calling up the memory function:

- ▷ Comfort function, see page 55.
- ▷ Safety function, see page 55.

### Convenience function

1. Open the driver's door.
2. Switch ignition off if necessary.
3. Briefly press button 1 or 2 as desired.

The relevant seat adjustment is done automatically.

The process is cancelled if a seat adjustment switch or one of the buttons is pressed.

### Safety function

1. Close the driver's door or switch the ignition on.
2. Keep button 1 or 2 pressed as desired until the adjustment procedure has been concluded.

### Calling up has been disabled

After a short time, calling up saved seat positions is disabled to prevent the battery from being discharged.

To reactivate calling up:

- ▷ Open and close a door or the boot lid.
- ▷ Press a button on the remote control.
- ▷ Press the start/stop button.

## Mirrors

### Exterior mirrors

#### General

Depending on the equipment, the mirror setting is saved for the profile currently in use. When the vehicle is unlocked using the remote control, this position is called up automatically if the setting for this has been enabled.

#### Note



#### WARNING

Objects reflected in the mirrors are closer than they appear. The distance to road users behind the vehicle could be incorrectly estimated, for example when changing lane. Danger of accidents. Look over your shoulder to estimate the distance from following traffic. ◀

### Overview



- 1 Adjusting 56
- 2 Left/right, automatic parking function
- 3 Folding in and out 56

## Selecting a mirror



Switching to other mirror:  
Push switch.

## Electrical adjustment



Corresponding to movement of button

## Saving positions

Seat and mirror position memory, see page 54.

## Adjusting manually

In the event of an electrical defect, for example, press the borders of the mirror glass.

## Automatic parking function

### Principle

When reverse gear is engaged, mirror glass on front passenger side is tilted downwards. This improves the view of the kerb or other obstacles near the ground, for example when parking.

### Activating

1.  Push switch to driver's mirror position.
2. Engage selector lever position R.

### Deactivating

Push switch to front passenger's mirror position.

## Folding in and out



### ATTENTION

Due to the vehicle's width, it could sustain damage in car washes. Danger of damage to property. Fold in the mirrors manually or using the button prior to washing.◀



Press the button.

Possible up to approximately 20 km/h, approximately 15 mph.

Advantageous in the following situations:

- ▷ In car washes.
- ▷ In narrow streets.
- ▷ When folding mirrors back out that have been folded in manually.

Folded-in mirrors automatically fold out at approximately 40 km/h, approximately 25 mph.

## Automatic heating

Both exterior mirrors are automatically heated with the engine running.

## Automatically dimming

Both exterior mirrors are automatically dimmed. Photocells in the rear-view mirror, see page 56, are used for control.

## Rear-view mirror, automatic-dim

### Principle

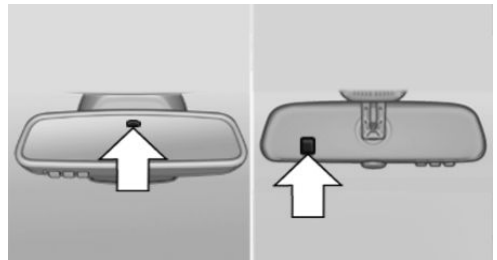

The function is controlled by photocells:

- ▷ In the mirror glass
- ▷ On the back of the mirror.

## Operating requirements

To keep the system functioning properly:

- ▷ Keep photocells clean.
- ▷ Do not obstruct the zone between the rear-view mirror and windscreen.

## Steering wheel

### Note

**⚠ WARNING**  
Steering wheel adjustment during the journey can lead to unexpected steering wheel movements. You could lose control of the vehicle. Danger of accidents. Only adjust the steering wheel when the vehicle is at a standstill. ◀

### Electric steering wheel lock

With manual gearbox: The steering wheel locks automatically when the driver's door is opened.

Switch on ignition to unlock.

**⚠ WARNING**  
If steering wheel lock is activated, the vehicle cannot be steered. Danger of accidents. Switch on the ignition prior to moving the vehicle. ◀

### Adjusting

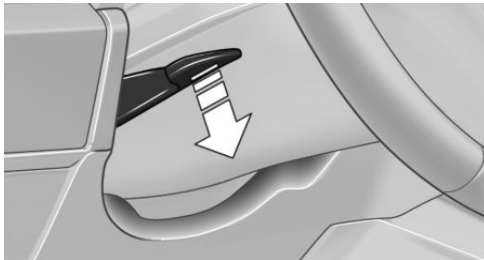

1. Fold the lever downwards.
2. Move the steering wheel to the preferred height and angle to suit your seated position.
3. Swing the lever back up.

## Steering wheel heating

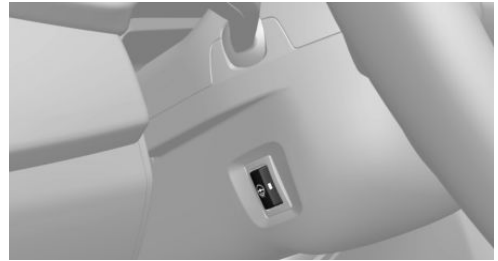

**ⓘ** Press the button.

- ▷ On: LED is illuminated.
- ▷ Off: LED turns off.

# Carrying children in safety

## Vehicle equipment

This chapter describes all standard, national and special equipment provided in the model series. Equipment not available in the vehicle is therefore also described, for example the se-

lected special equipment or national version. This also applies to safety-relevant functions and systems. Comply with the relevant national regulations when using the corresponding functions and systems.

## Important considerations

### Note



#### WARNING

Unsupervised children or animals in the vehicle can set the vehicle in motion and endanger themselves or other road users, for example by the following actions:

- ▷ Pressing the start/stop button.
- ▷ Releasing the parking brake.

- ▷ Opening and closing doors or windows.
- ▷ Setting the selector lever to neutral.
- ▷ Operating vehicle equipment.

Risk of accident or injury. Do not leave children or animals unsupervised in the vehicle. When leaving the vehicle, take the remote control with you and lock it. ◀

### Not for Australia/New Zealand: Suitable seats

Information about which child seats can be used on the seats in question, if the child seats

are attached with a seat belt — according to ECE-R 16 standard:

Group	Weight of child	Approximate age	Front passenger's seat	Rear seats, outer – b)	Rear seat, middle
0	Up to 10 kg	Up to 9 months	U	U	X
0+	Up to 13 kg	Up to 18 months	U	U	X
I	9 – 18 kg	Up to 4 years	U	U	X
II	15 – 25 kg	Up to 7 years	U	U	X

Group	Weight of child	Approximate age	Front passenger's seat	Rear seats, outer – b)	Rear seat, middle
III	22 – 36 kg	7 years or more	U	U	X

U: suitable for child restraint systems in Universal category that have been approved for use in this weight group.

X: not suitable for child restraint systems in Universal category that have been approved for use in this weight group.

b) When using child seats on the rear seats, adapt the front/back position of the front seat if necessary, and also adjust the head restraint of the rear seat, or remove it.

### Always carry children at the rear



#### WARNING

Persons less than 150 cm, 5 ft in height cannot put on the seat belt correctly without using additional restraint systems. The protective effect of the seat belts can be restricted or they can be rendered ineffective if put on incorrectly. If a seat belt is not worn correctly, additional injuries can be caused, for example in the event of an accident or braking and evasive manoeuvres. Danger of injury or life. Persons less than 150 cm, 5 ft must be secured in suitable restraint systems. ◀

Accident research has shown that the safest place for children is on the rear seat.

Children younger than 12 years old or less than 150 cm, 5 ft in height are only allowed to be transported in the rear using child restraint systems appropriate for their age, weight and stature.

### Not for Australia/New Zealand: Children on the front passenger's seat

When using a child restraint system on the front passenger seat, make sure that the front and side airbags on the passenger's side are deactivated. Front passenger airbags can only be deactivated with the key switch for front passenger airbags, see page 106.

### Note



#### WARNING

Active front passenger airbags can injure a child in a child restraint system if they are triggered. Danger of injury. Make sure that the front passenger airbags are deactivated and the PASSENGER AIRBAG OFF indicator light is illuminated. ◀



#### WARNING

If the seat adjustment or child seat installation is incorrect, the stability of the child restraint system will be restricted or rendered ineffective. Danger of injury or life. Make sure the child restraint system is firmly positioned against the backrest. In all relevant backrests, adapt the backrest angle if possible and set the seats correctly. Make sure that the seats and their backrests are correctly engaged. If possible, adjust the height of the head restraints, or remove them. ◀

## Fitting child restraints

### Child restraints

Child restraints for every age and weight class are available from a Service Partner or a qualified specialist workshop.

## Notes

When selecting, installing and using child restraint systems, comply with the information provided by the manufacturer of the child restraint system.

### WARNING

If child restraint systems and their attachment systems have been damaged or subjected to stresses in an accident, their protective function may be restricted or rendered ineffective. A child might not be adequately restrained, for example, in the event of an accident or braking and evasive manoeuvres. Danger of injury or life. If child restraint systems and their attachment systems have been damaged or subjected to stresses in an accident, have them checked by the Service Partner or a qualified specialist workshop and renewed if necessary. ◀

### WARNING

If the seat adjustment or child seat installation is incorrect, the stability of the child restraint system will be restricted or rendered ineffective. Danger of injury or life. Make sure the child restraint system is firmly positioned against the backrest. In all relevant backrests, adapt the backrest angle if possible and set the seats correctly. Make sure that the seats and their backrests are correctly engaged. If possible, adjust the height of the head restraints, or remove them. ◀

## For Australia/New Zealand: installation of child restraints

Please note the following warning because your vehicle has been equipped with a front airbag for the front passenger's seat that cannot be deactivated:



It is recommended not to use any kind of child restraint system on the front passenger's seat.



Extreme hazard

Do not use a rearward facing child restraint on a seat protected by an airbag in front of it. ◀

## Not for Australia/New Zealand: On the front passenger's seat

### Deactivating airbags



WARNING

Active front passenger airbags can injure a child in a child restraint system if they are triggered. Danger of injury. Make sure that the front passenger airbags are deactivated and the PASSENGER AIRBAG OFF indicator light is illuminated. ◀

Before fitting a child restraint in the front passenger's seat, make sure that the front and side airbags on the passenger's side are disabled.

Deactivating the front passenger airbags with key switch, see page 106.

### Rear-facing child restraints



DANGER

Active front passenger airbags can fatally injure a child in a rearward-facing child restraint system if they are triggered. Danger of injury or life. Make sure that the front passenger airbags are deactivated and the PASSENGER AIRBAG OFF indicator light is illuminated. ◀



Follow the information on the front passenger sun visor.

### Seat position and height

Before mounting a universal child restraint system, move the front passenger's seat as far

to the rear and as far up as possible to achieve the best possible routing of the belt and protection in the event of an accident.

If the upper attachment point of the seat belt is located ahead of the child seat's belt guide, carefully move the front passenger's seat forwards until the best possible belt guidance is achieved.

### Backrest width

With adjustable backrest width: before fitting a child restraint system in the front passenger's seat, fully open the backrest width. Do not change the backrest width from this point on and do not call up a memory position.

## ISOFIX child seat mountings

### Note

Note for Australia: ISOFIX child seats are not permitted for road use in Australia at the time of printing of this handbook. However, also since a change of the respective regulations is expected in the future, lower ISOFIX ancho-

rages are supplied in line with applicable ADRs also for Australia.

Comply with the operating and safety instructions from the manufacturer of the child restraint system when attaching and using ISOFIX child restraint systems.

### Suitable ISOFIX child restraints

Group	Weight of child	Approximate age	Class/category – a)	Front passenger's seat	Rear seats, outer	Rear seat, middle
0	Up to 10 kg	Approximately 9 months	E - ISO/R1	X	IL	X
0+	Up to 13 kg	Approximately 18 months	E - ISO/R1	X	IL	X
			D - ISO/R2	X	IL	X
			C - ISO/R3	X	IL	X

Group	Weight of child	Approximate age	Class/category – a)	Front passenger's seat	Rear seats, outer	Rear seat, middle
I	9 - 18 kg	Up to approximately 4 years	D - ISO/R2	X	IL	X
			C - ISO/R3	X	IL	X
			B - ISO/F2	X	IL, IUF	X
			B1 - ISO/F2X	X	IL, IUF	X
			A - ISO/F3	X	IL, IUF	X

IL: the seat is suitable for installation of an ISOFIX child seat in the Semi-Universal category subject to compliance with the list of vehicles accompanying the child seat.

IUF: the seat is suitable for installation of an ISOFIX child seat with Universal approval and attachment with the TOP TETHER strap.

X: the seat is not approved or equipped with mounting points for the ISOFIX system.

a) When using child seats on the rear seats, adapt the front/back position of the front seat if necessary, and also adjust the head restraint of the rear seat, or remove it.

## Brackets for lower ISOFIX anchors

### Information

#### WARNING

If the ISOFIX child restraint systems are not engaged correctly, the protective effect of the ISOFIX child restraint systems may be restricted. Danger of injury or life. Make sure the lower anchor point has engaged correctly and the ISOFIX child restraint system is firmly positioned against the backrest. ◀

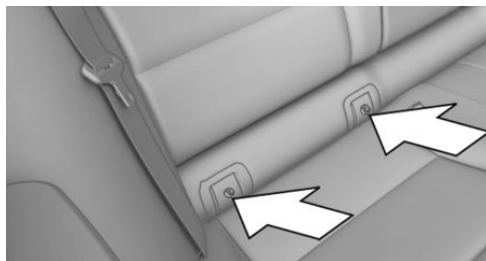

The brackets for the lower ISOFIX anchors are located behind the marked covers.

### Position



The corresponding symbol shows the brackets for the lower ISOFIX anchor points.



### Before fitting ISOFIX child restraints

Pull the belt out of the area of the child seat mountings.

### Fitting of ISOFIX child restraint systems

1. Install the child restraint system, see manufacturer's information.
2. Make sure that both ISOFIX anchors have snapped into place.

## Upper ISOFIX retaining strap

### Mounting points



The symbol shows the mounting point for the upper retaining strap.

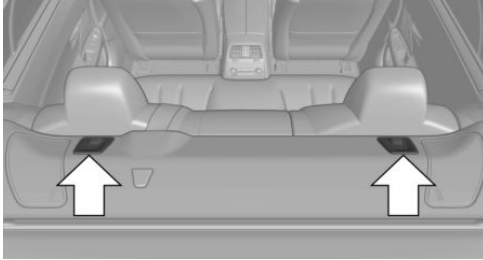

There are two mounting points for the upper retaining strap of ISOFIX child restraints.

### Note



#### ATTENTION

The mounting points for the upper retaining straps of child restraint systems are only intended for these retaining straps. The mounting points can be damaged if other objects are attached. Danger of damage to property. Only attach child restraint systems to the upper retaining straps. ◀

### Guiding the retaining strap



#### WARNING

If the upper retaining strap is used incorrectly with the child restraint system, the protective effect may be reduced. Danger of injury. Make sure that the upper retaining strap is not routed to the upper attachment strap over sharp edges, and that it is not twisted. ◀

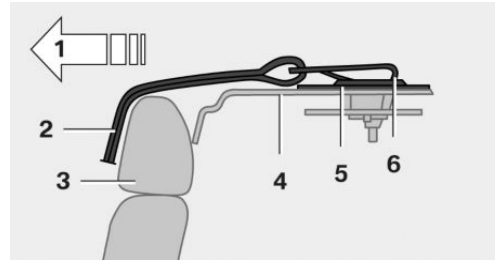

- 1 Direction of travel
- 2 Upper retaining strap
- 3 Head restraint
- 4 Rear parcel shelf
- 5 Mounting point
- 6 Hook for the upper retaining strap

### Attaching the upper retaining strap to the mounting point

1. Fold up the fastening point cover.
2. Guide the upper retaining strap over the head restraint.
3. Engage the hook of the retaining strap in the mounting point.
4. Pull the restraining strap firmly down.

## For Australia/New Zealand: Child restraints

### Information

In accordance with ADR 34/01, provisions have been made to allow installation of a child restraint at each rear seating position.

The anchoring hooks which belong to the upper restraining strap of the child restraint - AS 1754, can be applied immediately to the relevant mounting.

Please refer strictly to the installation instructions supplied with the child restraint system. Each seating position is fitted with a head rest.

**WARNING**

Child restraint anchorages are designed to withstand only those loads imposed by correctly fitted child restraints. Under no circumstances are they to be used for adult seat belts, harnesses or for attaching other items or equipment to the vehicle. After using the child restraints, the anchor fittings may need to be folded down. ◀

## Mounting points



The symbol shows the mounting point for the upper retaining strap.

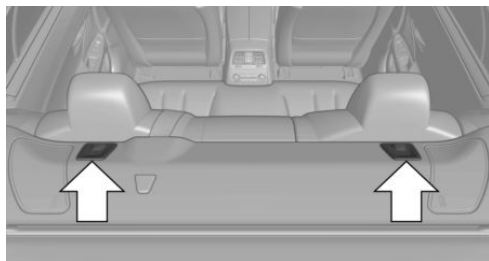

There are two mounting points for child restraints with tether straps.

## Guiding the retaining strap

**WARNING**

If the upper retaining strap is used incorrectly with the child restraint system, the protective effect may be reduced. Danger of injury. Make sure that the upper retaining strap is not routed to the upper attachment strap over sharp edges, and that it is not twisted. ◀

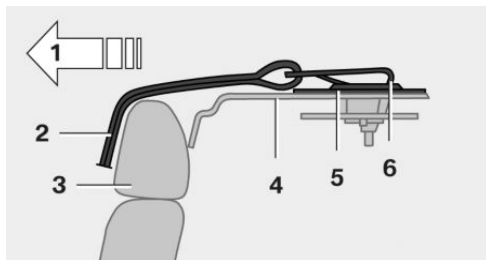

- 1 Direction of travel
- 2 Upper retaining strap
- 3 Head restraint
- 4 Rear parcel shelf
- 5 Mounting point
- 6 Hook for the upper retaining strap

## Attaching the upper retaining strap to the mounting point

1. Fold up the fastening point cover.
2. Guide the upper retaining strap over the head restraint.
3. Engage the hook of the retaining strap in the mounting point.
4. Pull the restraining strap firmly down.

# Driving

## Vehicle equipment

This chapter describes all standard, national and special equipment provided in the model series. Equipment not available in the vehicle is therefore also described, for example the selected special equipment or national version. This also applies to safety-relevant functions and systems. Comply with the relevant national regulations when using the corresponding functions and systems.

## Start/stop button

### Principle



The ignition is switched on or off and the engine is started by pressing the start/stop button.

M double clutch transmission:  
The engine starts if the brakes

are applied when the start-stop button is pressed.

Manual gearbox: The engine starts if the clutch pedal is pressed when pressing the start/stop button.

### Ignition on

M double clutch transmission: Press the start/stop button without applying the brakes.

Manual gearbox: Press the start/stop button, do not press the clutch pedal.

All systems are operational.

Most of the indicator and warning lamps in the instrument cluster are illuminated for different lengths of time.

To save battery power when the engine is off, switch off the ignition and any unnecessary electronic systems.

### Ignition off

M double clutch transmission: Press the start/stop button again without applying the brakes.

Manual gearbox: Press the start/stop button again, do not press the clutch pedal.

All indicator lights in the instrument cluster extinguish.

To save battery power when the engine is off, switch off the ignition and any unnecessary electronic systems.

### Notes

When the ignition is switched off, selector lever position P will be automatically engaged, if selector lever position D or R is engaged.

With the vehicle stationary and the engine shut down, the ignition is switched off automatically under the following circumstances:

- ▷ When locking, even with the low-beam headlights switched on.
- ▷ Shortly before the battery is discharged so that an engine start remains possible.
- ▷ When opening or closing the driver's door, if the driver's belt is unfastened and the low-beam headlights are switched off.
- ▷ When the driver's belt is unfastened, if the driver's door is opened and the low-beam headlights switched off.

After about 15 minutes without further operation, low-beam headlights are changed over to side lights.

### Radio ready state

Activate radio ready state: when the engine is running, press the start/stop button.

Individual electrical systems remain operational.

The radio ready state is automatically switched off in the following situations:

- ▷ After approximately eight minutes.
- ▷ When locking via the central locking system.
- ▷ Shortly before the battery is discharged so that an engine start remains possible.

Radio readiness remains active when ignition is switched off automatically, such as for following reasons:

- ▷ Opening or closing driver's door.
- ▷ Unfastening driver's seat belt.
- ▷ When low-beam headlights are automatically changed to side lights.

If engine is switched off and ignition is switched on, radio ready state will be automatically activated when door is opened if light is switched off or daytime driving lights are switched on, when corresponding equipment is fitted.

## Engine start

### Notes



#### DANGER

A blocked exhaust pipe or inadequate ventilation can allow harmful exhaust fumes to penetrate the vehicle. The exhaust gas contains carbon monoxide, which is colourless and odourless, but highly toxic. In enclosed spaces, the exhaust fumes can also build up outside the vehicle. Danger of fatal injury. Keep the exhaust pipe clear and ensure sufficient ventilation. ◀



#### WARNING

An unsecured vehicle can start moving and rolling away. Danger of accidents. Before leaving the vehicle, secure it to prevent rolling away.

Observe the following to ensure that the vehicle is secured against rolling away:

- ▷ Engage the parking brake.

- ▷ Turn the front wheels into the direction of the kerb on upward or downward gradients.
- ▷ Additionally secure the vehicle on upward or downward gradients, e.g. using a wedge. ◀



#### ATTENTION

Repeated start attempts or starting several times in quick succession means that fuel is not combusted, or insufficiently so. The catalytic converter can overheat. Danger of damage to property. Avoid starting more than once in quick succession. ◀

## M double clutch transmission

### Starting the engine

1. Press the brake.
2. Press the start/stop button.

Starting proceeds for a certain time automatically and stops as soon as the engine is started.

### Manual gearbox

#### Starting the engine

1. Press the brake.
2. Depress the clutch and engage idle position.
3. Press the start/stop button.

Starting proceeds for a certain time automatically and stops as soon as the engine is started. ◀

## Stopping the engine

### Notes



#### WARNING

Unsupervised children or animals in the vehicle can set the vehicle in motion and endanger themselves or other road users, for example by the following actions:

- ▶ Pressing the start/stop button.
- ▶ Releasing the parking brake.
- ▶ Opening and closing doors or windows.
- ▶ Setting the selector lever to neutral.
- ▶ Operating vehicle equipment.

Risk of accident or injury. Do not leave children or animals unsupervised in the vehicle. When leaving the vehicle, take the remote control with you and lock it. ◀



#### WARNING

An unsecured vehicle can start moving and rolling away. Danger of accidents. Before leaving the vehicle, secure it to prevent rolling away.

Observe the following to ensure that the vehicle is secured against rolling away:

- ▶ Engage the parking brake.
- ▶ Turn the front wheels into the direction of the kerb on upward or downward gradients.
- ▶ Additionally secure the vehicle on upward or downward gradients, e.g. using a wedge. ◀

### Before entering the car wash

So that the vehicle can roll into the vehicle wash, follow the information on washing in automatic vehicle washes, see page 208.

### M double clutch transmission

#### Stopping the engine

1. Brake the vehicle until it comes to a stop.

2. Press the start/stop button.  
The engine is switched off.  
The radio ready state is switched on.
3. Apply the parking brake.

### Manual gearbox

#### Stopping the engine

1. Press the Start/Stop button when the vehicle is at standstill.
2. Engage first gear or reverse.
3. Apply the parking brake.

## Auto Start Stop function

### Principle

The Auto Start Stop function helps you to save fuel, by stopping the engine when stationary, for example, in a traffic jam or at traffic lights. The ignition remains switched on. For driving off, the engine starts automatically.

### Automatic operation

After each time the engine is started using the start/stop button, the Auto Start Stop function is ready to operate.

The function is activated from 5 km/h, 3 mph 3 mph, km/h.

### Stopping the engine

The engine is automatically shut down when stationary under the following conditions:

M double clutch transmission:

- ▶ Selector lever in selector lever position D.
- ▶ Brake pedal remains depressed while the vehicle is at a standstill.
- ▶ Driver's seat belt buckled or driver's door closed.

Manual gearbox:

- ▶ Transmission in neutral and clutch pedal not pressed.

- ▷ Driver's seat belt buckled or driver's door closed.

The air flow rate of the air conditioning system is reduced when the engine is not running.

## Displays in the instrument cluster



The display READY in the revolution counter indicates that the Auto Start Stop function is ready for automatic engine starting.



The display indicates that the preconditions for an automatic engine stop are not met.

## Restrictions of the function

The engine is not shut down automatically in the following situations:

- ▷ Outside temperature too low.
- ▷ High outside temperature and operation of the automatic air conditioning.
- ▷ Interior not heated or cooled to the desired temperature.
- ▷ Engine is not yet at operating temperature.
- ▷ Sharp steering angle or steering operation.
- ▷ After reversing.
- ▷ Condensation when the automatic air conditioning is switched on.
- ▷ Vehicle battery is heavily discharged.
- ▷ At high altitudes.
- ▷ Bonnet is unlocked.
- ▷ Parking assistant is activated.
- ▷ Stop-and-go traffic.
- ▷ Use of fuel with high ethanol content.

## Engine start

For driving off, the engine automatically starts under the following conditions:

- ▷ M double clutch transmission:  
By releasing the brake pedal.
- ▷ Manual gearbox:  
Clutch pedal is depressed.

After starting the engine, accelerate as normal.

## Safety function

After an automatic shut down, the engine will not restart automatically if one of the following conditions is satisfied:

- ▷ Driver's seat belt unbuckled and driver's door open.
- ▷ Bonnet has been unlocked.

Several indicator lights illuminate for various lengths of time.

The engine can only be started using the start/stop button.

## Restrictions of the function

Even if you do not want to drive off, the engine restarts automatically in the following situations:

- ▷ Very high temperature inside the passenger compartment, if the cooling function is on.
- ▷ The driver applies lock to the steering wheel.
- ▷ M double clutch transmission: Shift from selector lever position D to N, R or D/S.
- ▷ M double clutch transmission: Depress the accelerator and the brake at the same time.
- ▷ Vehicle starts to roll.
- ▷ Condensation when the automatic air conditioning is switched on.
- ▷ Vehicle battery is very low.
- ▷ Very low temperature inside the passenger compartment, if the heating is on.
- ▷ Low brake vacuum, for example because the brake pedal has been depressed a number of times in succession.

## Preventing automatic engine stop with M double clutch transmission

### Principle

To enable the vehicle to move off particularly swiftly, for example at a junction, the automatic engine stop can be actively prevented.

### Preventing automatic engine stop using the brake pedal

The engine stop can be actively prevented within a second of the vehicle coming to a standstill:

- ▶ Press the brake pedal down firmly as soon as the vehicle has come to a standstill.
- ▶ Then immediately brake again with normal braking force.

## Manually deactivating/activating the system

### Using the button

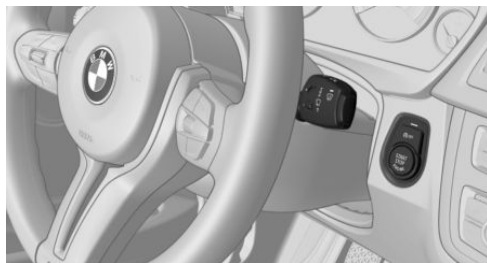

 Press the button.

- ▶ LED illuminates: Auto Start Stop function is deactivated.  
During an automatic engine stop, the engine is started.  
The engine can be started or stopped only by means of the start/stop button.
- ▶ LED goes out: Auto Start Stop function is activated.

## Parking the vehicle during automatic engine stop

With automatic engine stop, the vehicle can be parked safely, for example in order to leave it.

1. Press the start/stop button. The ignition is switched off. The Auto Start Stop function is deactivated.  
P is engaged automatically.
2. Apply the parking brake.

Start engine as usual, using the start/stop button.

### Automatic deactivation

In certain situations the Auto Start Stop function is deactivated automatically for safety's sake, for example if the absence of the driver is detected.

### Malfunction

The Auto Start Stop function no longer shuts down the engine automatically. A Check Control message is displayed. It is possible to keep driving. Have the system checked.

## Parking brake

### Applying

The lever engages itself after pulling up.



The indicator light illuminates red. The parking brake is engaged.

If it must be used while driving by way of exception, slightly engage the parking brake while pressing and holding the button.

To avoid corrosion and one-sided braking effect, slightly pull on the parking brake from time to time when moving away, if traffic conditions allow.

The brake lights do not illuminate when the parking brake is applied.

## Releasing

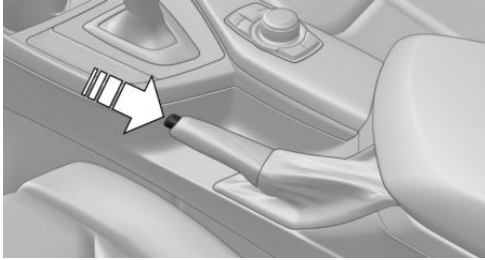

Pull up the lever a bit, press the button and guide the lever down.

## Turn indicators, high-beam headlights, headlight flasher

### Turn indicator

#### Turn indicator in exterior mirror

Do not fold in the exterior mirrors while driving or while operating the turn indicators or hazard warning lights to ensure that the turn indicators in the exterior mirrors are well recognisable.

### Indicating

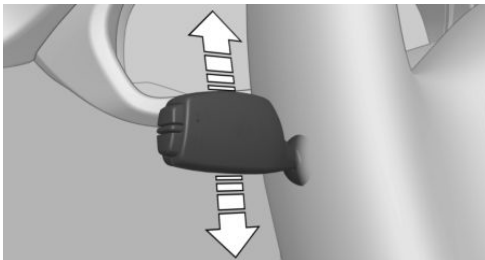

Press the lever beyond the resistance point.

The turn indicator lever returns to its initial position after activation.

To cancel the signal manually, press the lever softly as far as the resistance point.

### Triple turn signal

Touch the lever softly.

The turn indicator flashes three times.

This function can be enabled or disabled.

On the Control Display:

1. "Settings"
2. "Lights"
3. "1-touch triple turn signal"

The setting is saved for the currently used profile.

### Indicating a turn briefly

Press the lever as far as the resistance point and hold it there for as long as you wish to indicate a turn.

### Malfunction

If the indicator light flashes more rapidly than usual, a turn signal light has failed.

### High-beam headlights, headlight flasher

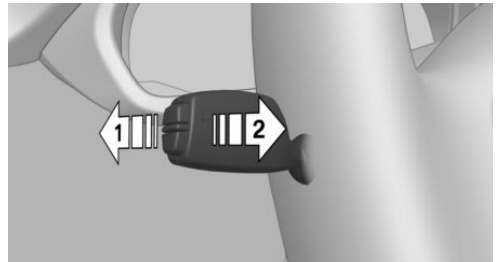

- ▷ High-beam headlights, arrow 1.
- ▷ High-beam headlights off/headlight flasher, arrow 2.

## Wiper system

### Switching the wipers on/off and flick-wiping

#### General

Do not use wipers with a dry windscreen, otherwise the wiper blades will wear or become damaged more quickly.

#### Notes

##### ATTENTION

If the wipers have frozen on, switching on can cause the wiper blades to tear and the wiper motor to overheat. Danger of damage to property. Defrost the windscreen before switching on the wipers. ◀

##### WARNING

If the wipers start moving when they are folded away from the windscreen, this can damage parts of the vehicle, or trap body parts. Danger of injury or damage to property. Make sure that the vehicle is switched off when the wipers are folded away from the windscreen, and that the wipers are in contact with the windscreen when switching on. ◀

#### Switching on

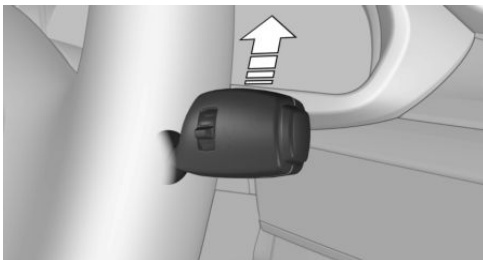

The lever returns to the basic position when released.

- ▷ Normal wiping speed: press upwards once.  
When the vehicle is at a standstill, the wipers switch to intermittent operation.

- ▷ Rapid wiping speed: press upwards twice or press once beyond the resistance point.  
When the vehicle is at a standstill, the wipers switch to normal speed.

#### Switching off and flick-wiping

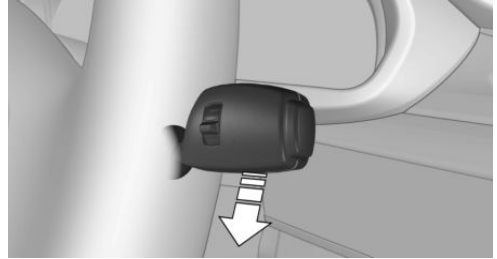

The lever returns to the basic position when released.

- ▷ Flick-wiping: press downwards once.
- ▷ Switching off normal wiping speed: press downwards once.
- ▷ Switching off fast wiping speed: press downwards twice.

#### Intermittent mode or rain sensor

##### Principle

Without rain sensor, the interval for the wiper operation is specified.

The rain sensor automatically controls the wiper operation depending on the rain intensity. The sensor is mounted on the windscreen, directly in front of the rear-view mirror.

## Activating/deactivating

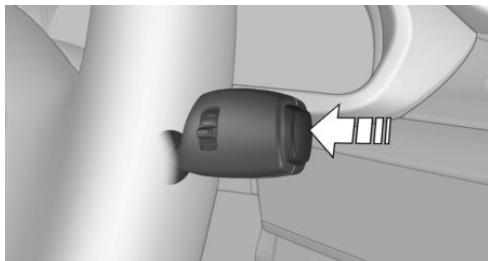

Press the button on the wiper lever.

Wiping is started. If a rain sensor is fitted: LED in wiper lever illuminates.

If there is frost, no wiping process is started.

### ATTENTION

In car washes, the wipers may inadvertently start moving if the rain sensor is activated. Danger of damage to property. Deactivate the rain sensor in car washes. ◀

## Setting the interval time or sensitivity of the rain sensor

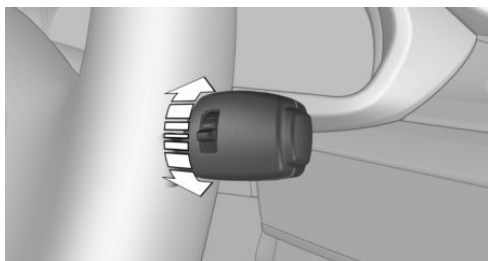

Turn the knurled wheel to set the interval time or sensitivity of the rain sensor.

Up: short interval or high sensitivity of the rain sensor.

Down: long interval or low sensitivity of the rain sensor.

## Cleaning the window glass, headlights

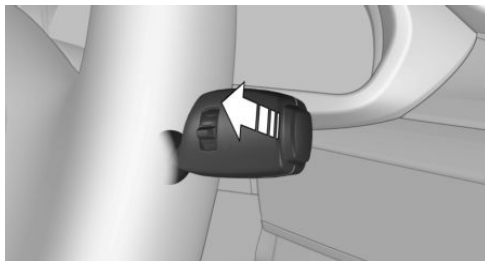

Pull the wiper lever.

Fluid from the washer fluid reservoir is sprayed onto the windscreen and the wipers are operated briefly.

When the vehicle's lights are switched on, the headlights are also cleaned simultaneously at practical intervals.

### WARNING

At low temperatures, the washer fluid can freeze onto the windscreen and restrict visibility. Danger of accidents. Only use the washer systems if there is no possibility of the washer fluid freezing. Use anti-freeze if required. ◀

### ATTENTION

If the washer fluid reservoir is empty, the washer pump cannot operate as intended. Danger of damage to property. Do not use the washer system with the washer fluid reservoir empty. ◀

## Windscreen washer jets

Windscreen washer jets are automatically heated when the ignition is switched on.

## Fold-out position of the wipers

This is important, for example for replacing the wiper blades or folding them out in the event of frost.

**WARNING**

If the wipers start moving when they are folded away from the windscreen, this can damage parts of the vehicle, or trap body parts. Danger of injury or damage to property. Make sure that the vehicle is switched off when the wipers are folded away from the windscreen, and that the wipers are in contact with the windscreen when switching on. ◀

1. Switch ignition on and back off again.
2. If there is a risk of frost, make sure that the wiper blades are not frozen.
3. Press the wiper lever upwards beyond the resistance point and hold it there for approximately three seconds until the wipers come to a standstill in a nearly vertical position.

After folding the wipers in, the wiper system must be reactivated.

1. Switch on ignition.
2. Press the wiper lever downwards. The wipers move to the rest position and are operational once again.

## Washer fluid

### Information

**WARNING**

Some anti-freezes can contain toxic substances, and are flammable. Risk of fire and fatal injury. Comply with the notes on the containers. Keep anti-freezes away from sources of combustion. Do not pour service products into other bottles. Keep service products out of the reach of children. ◀

**WARNING**

Work performed incorrectly under the bonnet can damage components and lead to a safety risk. Danger of accident or damage to property. Have work under the bonnet carried

out by a Service Partner or a qualified specialist workshop. ◀

### Reservoir for washer fluid

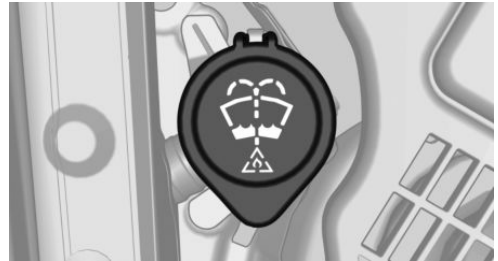

All washer jets are supplied from one tank in the engine compartment.

When filling with a mixture of screenwash concentrate and tap water, to which anti-freeze has been added if required, always follow the manufacturer's instructions.

Before topping up, mix the washer fluid to comply with the mixture ratio.

Do not top up with undiluted screenwash concentrate and anti-freeze and do not top up with pure water; that may damage the washer system.

Do not mix any screenwash concentrates of different manufacturers, as this may otherwise block the washer nozzles.

Recommended minimum fill level: 1 litre, approximately 1.7 Imp. pints.

## Manual gearbox

### Shifting gears

**ATTENTION**

When shifting into a lower gear, high engine speeds can damage the engine. Danger of damage to property. Push the shift lever to the right while shifting into the 5th or 6th gear. ◀

## Reverse gear

Engage this position only when the vehicle is stationary.

To overcome the resistance of the selector lever move in a dynamic movement towards the left and engage the reverse gear.

## M double clutch transmission with Drivelogic

### General

The M double clutch transmission with Drivelogic is an automated manual gearbox with two clutches and partial gears, by which the gears are changed without interrupting traction.

It is operated using the selector lever or two paddles on the steering wheel.

### Functions

- ▷ Drive mode or sequential mode.
- ▷ Various drive programs, Drivelogic.
- ▷ Shift Lights, see page 96
- ▷ Automatic downshift and protection against shifting even in sequential mode.
- ▷ Launch Control.
- ▷ Low Speed Assistant.

## Selector lever, selector lever position

### Overview



- ▷ R: reverse.
- ▷ N: neutral, idling.

- ▷ Centre position, forward setting.
- ▷ +: manually change up.
- ▷ -: manually change down.
- ▷ D/S: change between drive mode and sequential mode.

### Engaging selector lever position

Press the brake pedal and push or pull the selector lever in the appropriate direction.

As soon as the selector lever is released, it returns to the central position. The selector lever engages into position R.

The engaged selector lever position is shown in the instrument cluster and on the selector lever.

After a selector lever position has been engaged, the vehicle can roll away when the brake is released, for example on a downhill slope. As a result, drive away immediately after releasing the brake.

Use the Low Speed Assistant when manoeuvring or in stop-and-go traffic.

### Low Speed Assistant

#### Principle

The Low Speed Assistant provides support at very low speeds. The vehicle drives at walking pace.

Can also be used for rocking out on snow. To do that, shift between reverse gear and forward position, without apply the brakes.

#### Note



#### ATTENTION

The transmission can overheat when using the function and depressing the brake pedal at the same time for an extended time. Danger of damage to property. Do not brake for an extended time when using the function. ◀

## Activating

1. Engage a drive position.
2. Briefly tap on the accelerator pedal.

The vehicle rolls at minimum speed.

This is possible in 1st and 2nd gear and in reverse.

## Deactivating

Brake the vehicle until it comes to a stop.

## Flashing display on selector lever of double clutch transmission

In some situations, the actually engaged gearbox setting may be different from the selector lever position, and the display in the selector lever flashes.

In these cases, refer to the display in the instrument cluster, see page 75.

## D Drive mode

In drive mode, all forward gears are automatically changed.

Kick-down: for maximum acceleration, for example, when overtaking. To do that, depress the accelerator pedal beyond the resistance point.

Change to sequential mode: shift using the shift paddles or push the selector lever in the D/S direction.

## S sequential mode

Change up or change down using the shift paddle or selector lever without coming off the gas.

- ▷ Shortly before a minimum speed depending on the gear, it automatically downshifts.
- ▷ The gears are only shifted up or down with the appropriate engine speed and road speed.

For example, there is no downshift at too high an engine speed.

- ▷ Kick-down: by operating the kick-down and the left shift paddle or selector lever at the same time, you can change down to the lowest possible gear.
- ▷ Driving off is possible even in 2nd gear on a level carriageway, for example, when it is smooth.

To change to Drive mode: press selector lever in the D/S direction.

## R Reverse

Engage this position only when the vehicle is stationary.

For rocking out, even up to 10 km/h, approximately 6 mph is possible. To do that, shift between forward and reverse gear without applying the brakes.

## N Neutral, idling

Select this in a car wash, for example. The vehicle will then be able to move, see page 208.

## P Park

The driven wheels are locked.

Transmission position P is engaged automatically:

- ▷ After stopping the engine in the radio ready state, see page 65, or ignition off, see page 65, when position R or D is engaged.
- ▷ Position N is engaged and ignition is off.

## Displays in the instrument cluster

### Drive mode

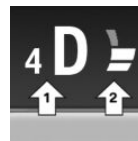

- ▷ Engaged gear together with a D, arrow 1.
- ▷ Selected drive program, Drivelogic, see page 76, arrow 2.

## Sequential mode



- ▷ Engaged gear, arrow 1.
- ▷ Selected drive program, Drivelogic, see page 76, arrow 2.
- ▷ Shift point indicator., see page 88

### Note

At very low outside temperatures, the display may not function. The current direction of travel can be recognised from the engaged selector lever position.

## Changing Gear

Changing is possible in sequential mode.

Changing in Drive mode has the effect of changing to sequential mode.

### Via the selector lever

- ▷ To shift up: pull the selector level backwards.
- ▷ To shift down: press the selector lever forwards.

### Using the paddle on the steering wheel

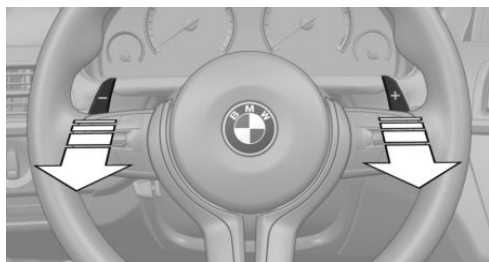

- ▷ Change up: pull right paddle.
- ▷ Change down: pull left paddle.

## Drivelogic

Various drive programs are available.

After each change between sequential mode and Drive mode, the last program selected is active.

Exception: after each engine start, drive program 1 in drive mode is active.

## In Drive mode

Three drive programs can be selected:

- ▷ 1: efficient driving.
- ▷ 2: relaxed driving.
- ▷ 3: dynamic driving.

## In sequential mode

Three drive programs can be selected:

- ▷ 1: comfortable gear changes.
- ▷ 2: sport, fast gear changes.
- ▷ 3: maximum changing speed, Launch Control, see page 77.

## Selecting drive program using button in centre console



 Press button until desired drive program is displayed in instrument cluster.

## Selecting drive program using M Drive

On the Control Display:

1. "Settings"
2. "M Drive 1" or "M Drive 2"
3.  Select the symbol.
4. "Mode"

5. Turn the Controller until the desired setting is reached and press the Controller.
  - ▷ "D" Drive Mode.
  - ▷ "S" Sequential mode.
6. "Gear position"
7. Turn the Controller until the desired setting is reached and press the Controller.
8. Set other drive programs as necessary. Setting is immediately accepted with active M Drive.

To activate the desired M Drive with the selected settings, press the corresponding button on the steering wheel:



### WARNING

Depending on the settings, DSC may only be available to a limited extent or not at all. Danger of accident or damage to property. Observe the settings for DSC in M Drive and react actively if necessary. Adjust the driving style and react if necessary. ◀

### Display in the instrument cluster



Selected drive program corresponds to the number of illuminated fields.

## Launch Control

### Principle

Launch Control allows optimum acceleration when driving off on a non-slip road surface.

### General

Using Launch Control leads to preliminary component wear, as this function represents a very heavy load for the vehicle.

Do not use Launch Control when running in, see page 162.

### Requirements

Launch Control is available with an engine at operating temperature, so after an uninterrupted drive of at least 10 km, approximately 6 miles.

To start with Launch Control, do not engage the steering wheel.

### Activating Launch Control

1. Deactivate Dynamic Stability Control, see page 124.
2. Select sequential mode with gear 1 and drive program 3.
3. With the engine running, depress the brake with the left foot.
4. Depress accelerator pedal fully.
  - The engine speed when driving off is regulated.
  - The flag symbol appears in the instrument cluster.
5. Using the Cruise Control, change the engine speed when driving off by 500 rpm.
6. Release brake, vehicle accelerates. Continue to press accelerator pedal.

Upshifting happens automatically as long as the accelerator pedal is fully depressed.

Launch Control is only available again after a certain distance has been travelled.

### System limits

This gearbox has overheat protection, which protects the clutch against extreme loads.



- ▷ Indicator light illuminates yellow: gearbox too hot.
  - Avoid high engine load and frequent driving off.
- ▷ Indicator light illuminates red: gearbox overheated.

Moderate continued driving possible. Stop at the next opportunity, stop the engine and allow the gearbox to cool.

Avoid frequent, heavy driving off and on upward inclines, do not hold the vehicle by slightly giving gas with sliding clutch, otherwise the gearbox may overheat.

In traffic queues or at very low speeds, use the Low Speed Assistant, see page 74.

## M Engine Dynamics Control

### Principle

The M Engine Dynamics Control affects the response of the vehicle to movements of the accelerator pedal.

### Programs

Possibilities for adjusting the responsiveness:

- ▷ "Efficient": efficient, comfortable. Minimised consumption  
Ideal, for example, in city traffic or on snow
- ▷ "Sport": sporty, dynamic.
- ▷ "Sport Plus": spontaneous, direct. Maximum dynamics

### Selecting program

#### Via M Drive

On the Control Display:

1. "Settings"
2. "M Drive 1" or "M Drive 2"
3.  Select the symbol.
4. Select the desired channel.  
Setting is immediately accepted with active M Drive.

To activate the desired M Drive with the selected settings, press the corresponding button on the steering wheel:



### Using the button



 Press button until the desired program is displayed in the instrument cluster.

### Display in the instrument cluster

 Engine dynamics control with selected programs with activated display of the system states of the driving dynamics, see page 86.

# Displays

## Vehicle equipment

This chapter describes all standard, national and special equipment provided in the model series. Equipment not available in the vehicle is therefore also described, for example the se-

lected special equipment or national version. This also applies to safety-relevant functions and systems. Comply with the relevant national regulations when using the corresponding functions and systems.

## Overview, Instrument cluster

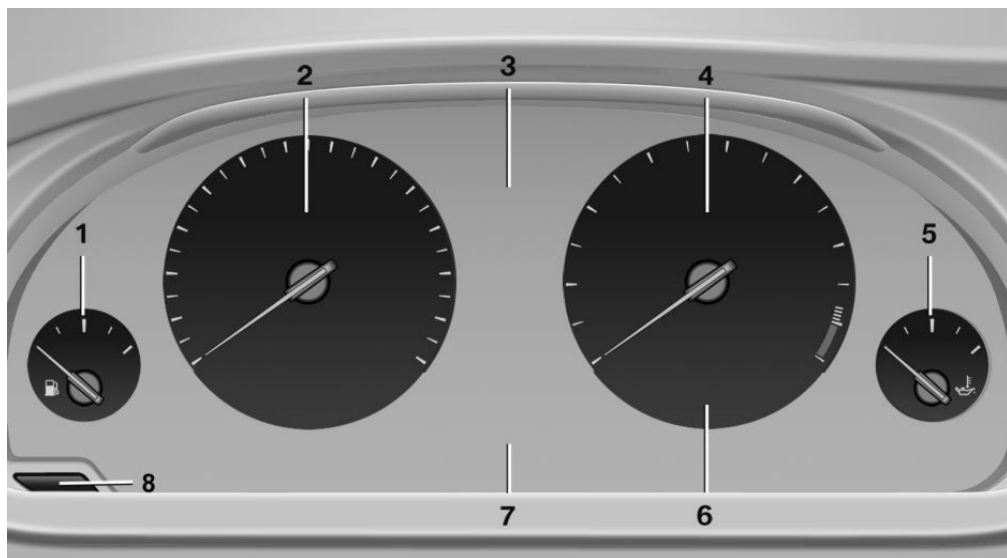

- |   |   |
|---|---|
| 1 Fuel gauge <a href="#">84</a>         | Shift Lights <a href="#">96</a>             |
| 2 Speedometer                           | 5 Engine oil temperature <a href="#">84</a> |
| 3 Messages, for example, Check Control  | 6 Current fuel consumption                  |
| 4 Revolution counter <a href="#">84</a> | 7 Electronic displays <a href="#">79</a>    |
|   | 8 Reset kilometres <a href="#">84</a>       |

## Electronic displays

- ▷ Selection lists, see page [90](#).
- ▷ Outside temperature, see page [84](#).
- ▷ Auto Start Stop function, see page [68](#).
- ▷ On-board computer, see page [90](#).
- ▷ Date, see page [85](#).
- ▷ Digital speedometer, see page [85](#).

- ▷ Energy recuperation, see page 86.
- ▷ Gear display with Drivelogic, see page 85.
- ▷ Seat belt reminder for rear seats, see page 53.
- ▷ Kilometres/trip odometer, see page 84.
- ▷ Messages, for example Check Control, see page 80.
- ▷ Current fuel consumption, see page 86.
- ▷ Navigation display, see Owner's Handbook for Navigation, Entertainment, Communication.
- ▷ Range, see page 85.
- ▷ Service requirements, see page 87.
- ▷ Speed Limit Information, see page 88.
- ▷ System states of the driving dynamics, see page 86.
- ▷ Time, see page 85.

## Check control

### Principle

The check control monitors vehicle functions and alerts you to any faults in the monitored systems.

A check control message is displayed as a combination of indicator or warning lights and text messages in the instrument cluster and the Head-Up Display.

If applicable, the text message shown in the Control Display is accompanied by an additional acoustic sound.

### Indicator and warning lamps

#### General

Indicator and warning lights in the instrument cluster can illuminate in a variety of combinations and colours.

When the engine starts or the ignition is switched on, the functionality of some lights is briefly checked.

## Red lights

### Seat belt reminder



Seat belt is not fastened on the driver's side. For some country versions: front passenger's seat belt is not fastened or objects are detected on the front passenger seat.

Flashing or illuminating: seat belt on the driver's or front passenger side is not fastened. The seat belt reminder can also be triggered if there are objects in the front passenger seat. Check whether the seat belt has been fastened correctly.

### Not for Australia/New Zealand: Belt reminder for rear seats



Red: seat belt not fastened on the corresponding rear seat.

Green: seat belt fastened on the corresponding rear seat.

### Airbag system



Airbag system and belt tensioner may be faulty.

Have vehicle immediately checked by a Service Centre or a qualified specialist workshop.

### Parking brake, brake system



For further information see release parking brake, see page 70.

### Front-end collision warning



Illuminating: forewarning, for example if a danger of collision is anticipated or

there is a very short distance to a vehicle ahead.

Increase distance.

Flashing: acute warning in the event of an immediate collision if the vehicle approaches another vehicle with relatively high differential speed.

Engage by braking and swerving as required.

### Person warning



Symbol in the instrument cluster.

If there is a risk of collision with a detected person, the symbol lights up and a signal sounds.

### Yellow lights

#### Anti-lock Brake System, ABS



Avoid abrupt braking if possible. Braking force reinforcement faulty. Consider longer braking distance. Have this immediately checked by a Service Centre or a qualified specialist workshop.

#### Dynamic Stability Control DSC



Flashing: DSC is regulating the acceleration and braking forces. The vehicle is stabilised. Decrease speed and adjust driving style to the road conditions.

Illuminating: DSC has failed. Have system checked by a Service Centre or a qualified specialist workshop.

For further information see Dynamic Stability Control, DSC, see page 124.

#### Dynamic Stability Control DSC deactivated



Dynamic Stability Control DSC is switched off.

For further information see Dynamic Stability Control DSC, see page 124.

### M Dynamic Mode



M Dynamic Mode MDM is switched on.

For more information, see M Dynamic Mode, see page 125.



Also flashing: MDM regulates acceleration and braking forces. The vehicle is stabilised.



Illuminated: MDM has failed. Have system checked by a Service Centre or a qualified specialist workshop.



For more information, see M Dynamic Mode, see page 125.

### Runflat indicator RPA



The runflat indicator reports a pressure loss in a tyre.

Reduce your speed and carefully stop the vehicle. Avoid violent or sudden braking and steering manoeuvres.

For more information, see Runflat indicator, see page 109.

### Tyre Pressure Monitor TPM



Illuminating: the Tyre Pressure Monitor reports a pressure loss in a tyre.

Reduce your speed and carefully stop the vehicle. Avoid violent or sudden braking and steering manoeuvres.

Flashing and then illuminating continuously: no flat tyres or loss of tyre pressure can be detected.

- ▶ Fault due to systems or devices with the same frequency: the system is automatically reactivated upon leaving the field of interference.

- ▶ TPM could not shut down the reset: execute a reset of the system again.

- ▶ Wheel without TPM electronics is fitted: have the vehicle checked by a Service Partner or a qualified specialist workshop if necessary.
- ▶ Malfunction: have the system checked by a Service Partner or a qualified specialist workshop.

For more information, see Tyre Pressure Monitor, see page [107](#).

### Steering system



Steering system faulty.

Have steering system checked by a Service Centre or a qualified specialist workshop.

### Engine functions



Have vehicle checked by a Service Centre or a qualified specialist workshop.

For further information see socket for on-board diagnosis, see page [192](#).

### Lane departure warning



System is switched on and warns you under certain conditions if you leave a detected lane without indicating first.

For further information see Lane Departure Warning, see page [115](#).

### Manual speed limiter



Illuminating: the system is switched on.  
Flashing: set speed limit exceeded. An acoustic signal may sound.

Reduce speed or deactivate system.

### Rear fog lights



Rear fog lights are switched on.

For further information see rear fog lights, see page [102](#).

### Green lights

#### Turn indicator



Turn signal is switched on.

If the indicator light flashes more rapidly than usual, a turn signal light has failed.

For further information see turn indicator, see page [70](#).

### Side lights, driving lights



Side lights or driving lights are switched on.

For further information see side lights/low-beam headlights, low-beam headlight control, see page [98](#).

### High-beam assistance



High-beam assistance is switched on.

High-beam headlights are switched on and off automatically depending on the traffic situation.

For further information see high beam assistance, see page [100](#).

### Cruise Control



The system is switched on. The speed set using the control functions on the steering wheel is maintained.

### Blue lights

#### High-beam headlights



High-beam headlights are switched on.

For further information see high-beam headlights, see page [70](#).

## General lights

### Check Control



At least one Check Control message is displayed or saved.

### M Drive



M Drive 1 is activated.



M Drive 2 is activated.

## Text messages

Text messages and symbols in the instrument cluster explain the meaning of a check control message and the indicator and warning lights.

### Supplementary text messages

You can call up additional information, for example the cause of the fault and any action required, via check control.

The supplementary text is automatically shown in the Control Display for urgent messages.

### Symbols

Depending on the Check Control message, the following functions can be selected.

- ▶ "Owner's Handbook"  
Display additional information on the Check Control message in the integrated Owner's Handbook.
- ▶ "Service request"  
Contact a Service Partner or a qualified specialist workshop.
- ▶ "Mobile Care"  
Contact the Mobile Service Centre.

## Hiding Check Control messages

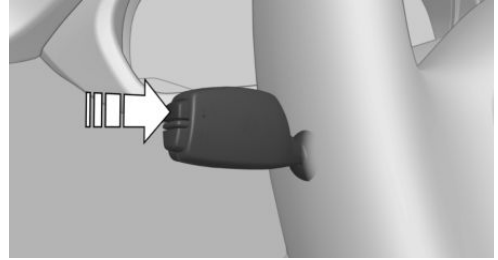

Press the button on turn indicator lever.

- ▶ Some Check Control messages are displayed permanently and remain until the fault has been repaired. If there are a number of malfunctions simultaneously, the messages are displayed in succession. These messages can be hidden for approximately eight seconds. They are then displayed again automatically.
- ▶ Other Check Control messages are automatically hidden after approximately 20 seconds. They remain saved and can be displayed again.

### Displaying check control messages saved in memory

On the Control Display:

1. "Vehicle information"
2. "Vehicle status"
3. "Check Control"
4. Select a text message.

### Messages displayed at the end of a journey

Certain messages displayed when driving are displayed again when the ignition is switched off.

## Fuel gauge



The vehicle inclination can lead to fluctuations in the display.

Depending on the equipment, the arrow next to the petrol pump symbol shows on which side of the vehicle the petrol tank flap is.

Information on refuelling, see page 172.

## Revolution counter



Yellow and red LEDs display permitted engine speed range. Permitted engine speed increases as engine oil temperature rises.

Avoid engine speeds in the yellow warning zone if possible.

It is vital to avoid engine speeds in the red warning zone. In this zone, the fuel supply is interrupted to protect the engine.

## Engine oil temperature



▶ Cold engine: the pointer is located at a low temperature value. Drive with moderate engine speed and vehicle speed.

▶ Normal operating temperature: the needle is located in the centre or left half of the temperature display.

▶ Hot engine: the pointer is located at a high temperature value. A check control message is also displayed.

## Coolant temperature

If the coolant and therefore the engine become too hot, a check control message is displayed.

Check coolant level, see page 189.

## Odometer and trip distance recorder

### Display



- ▶ Odometer, arrow 1.
- ▶ Trip distance recorder, arrow 2.

### Show/reset distance



Press the button.

- ▶ When the ignition is off, the time, outside temperature and odometer are displayed.
- ▶ When the ignition is on, the trip distance recorder is reset.

## Outside temperature

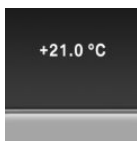

If the display drops to +3 °C/+37 °F or lower, a signal sounds.

A Check Control message is displayed.

There is an increased risk of black ice.

If the digital speedo is activated, the outside temperature can be displayed on the on-board computer.



### WARNING

Even at temperatures above +3 °C/+37 °F, there can be an increased danger of icy roads, e.g. on bridges or on shaded roads. Danger of accidents. At low temperatures, adjust the driving style to the weather conditions. ◀

## Time

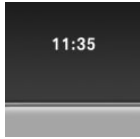

The time is shown in the instrument cluster.

If the digital speedo is activated, the time can be displayed on the on-board computer.

Setting the time and time format, see page 93.

## Date

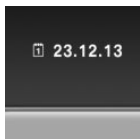

The date is displayed on the on-board computer.

Setting the time date and date format, see page 93.

## Digital speedometer

### Display

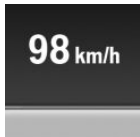

The current speed is shown in the instrument cluster.

### Activating display

1. "Settings"
2. "Instr. cluster display"
3. "Digital speedometer"

### Setting unit

1. "Settings"
2. "Language/units"
3. "Dig. speedo:"
4. Select the desired unit.

The setting is stored for the currently used profile.

## Gear display with Drivelogic

### Sequential mode



- ▷ Engaged gear, arrow 1.
- ▷ Selected drive program, Drivelogic, see page 76, arrow 2.

### Drive mode

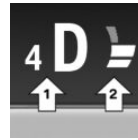

- ▷ Engaged gear together with a D, arrow 1.
- ▷ Selected drive program, Drivelogic, see page 76, arrow 2.

## Range

### Display

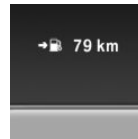

If there is a small remaining range:

- ▷ A Check Control message is briefly displayed.
- ▷ The On-board computer shows the remaining range.
- ▷ With dynamic driving style, for example fast cornering, the engine function is not always ensured.

If the range drops below approximately 50 km, approximately 30 miles the Check Control message is continually displayed.



### ATTENTION

If the range drops below 50 km, approx. 30 miles, the engine could not be supplied anymore with sufficient fuel. Engine functions are not ensured anymore. Danger of damage to property. Refuel in good time. ◀

## Current fuel consumption

### Display

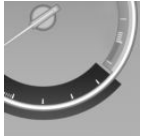

Shows the momentary fuel consumption. It is possible to check the economy and environmental compatibility of your driving style.

### Displaying the current fuel consumption

1. "Settings"
2. "Instr. cluster display"
3. If applicable, "M driving dynamics syst."
  - The current fuel consumption display is active.
  - Display of the driving dynamic systems, see page 86.

The bar gauge for the current fuel consumption is shown in the instrument cluster.

## Energy recuperation

### Display

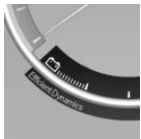

In the coasting mode, the kinetic energy of the vehicle is converted into electrical energy. The vehicle battery is partially charged and fuel consumption can be lowered.

### Displaying energy recuperation

1. "Settings"
2. "Instr. cluster display"
3. If applicable, "M driving dynamics syst."
  - The energy recuperation display is active.
  - Display of the driving dynamic systems, see page 86.

## EfficientDynamics display

### Displaying EfficientDynamics

When travelling, information on consumption and technology is shown.

1. "Vehicle information"
2. "EfficientDynamics"

### Showing fuel consumption history

The average fuel consumption can be shown in the set time span.

"Consumption history"

### Setting time fuel consumption history time span

Select the symbol.

### Resetting fuel consumption history

1. Calling up "Options".
2. "Reset consumption history"

### Showing EfficientDynamics Info

The current type of action can be shown.

"EfficientDynamics info"

The following systems are shown:

- ▷ Auto Start Stop function.
- ▷ Energy recuperation.
- ▷ Air conditioning power.

## Driving dynamic systems

### Display



The system states of the driving dynamics are shown in the instrument cluster.

Symbols	Description
	M engine dynamics control, see page 78.
	Adaptive M chassis, see page 126.
	Servotronic, see page 127.



## Activating display

1. "Settings"
  2. "Instr. cluster display"
  3. If applicable, "M driving dynamics syst."
- The drive dynamics systems display is active.
- Display current consumption, see page 86, and energy recovery, see page 86.

## Service requirements

### Principle

The distance to be driven or time to the next maintenance is displayed briefly after switching on the ignition briefly in the instrument cluster.

The current service requirements can be read by a service advisor from the remote control.

### Display

#### Detailed information on service requirements

More detailed information on the scope of maintenance can be displayed on the Control Display.

1. "Vehicle information"
2. "Vehicle status"
3.  "Service requirements"

Essential maintenance routines and any statutory inspections required are displayed.

4. Select an entry to display more detailed information.

## Symbols

Symbols	Description
	No servicing is currently needed.
	Maintenance or an inspection required by law is due soon.
	Servicing is overdue.



## Entering deadlines

Enter deadlines for prescribed statutory inspections.

Ensure that the date and time of the vehicle are set correctly.

On the Control Display:

1. "Vehicle information"
2. "Vehicle status"
3.  "Service requirements"
4. "§ vehicle inspection"
5. "Date:"
6. Adjust the settings.
7. Confirm.

The date input is saved.

## Automatic Service notification

Data on the service status or on statutory inspections for the vehicle are transmitted to the Service Partner automatically when a service or inspection is imminent.

It can be checked when the Service Partner was notified.

On the Control Display:

1. "Vehicle information"
2. "Vehicle status"
3. Call up "Options".
4. "Last Teleservice Call"

## Service history



### General

Have maintenance work carried out by a Service Partner or a qualified specialist workshop. Performed maintenance work is recorded in the vehicle data, see page 191.



The maintenance visits entered can be shown on the Control Display. Operation is available as soon as a maintenance visit has been entered in the vehicle data.

### Displaying service history

On the Control Display:

1. "Vehicle information"
2. "Vehicle status"
3.  "Service requirements"
4.  "Service history"  
Maintenance visits carried out are shown.
5. Select an entry to display more detailed information.

### Symbols

Symbols	Description
	Green: maintenance has been carried out on time.
	Yellow: maintenance has been carried out with a delay.
	Maintenance has not been carried out.

## Shift point indicator

### Principle

The system recommends the most efficient gear for the current driving situation.



### General

The shift point indicator is active in sequential mode of the M double clutch transmission and the manual gearbox.

Information on up or downshifting are displayed on the instrument cluster.

For vehicles without shift point indicator, the gear engaged is shown.

### Displays

Symbol	Description
	Shift up into most efficient gear.
	Shift down into most efficient gear.

## Speed Limit Information with No Passing Information

### Principle

#### Speed Limit Information

Speed Limit Information shows the currently detected speed limit in the instrument cluster. The camera in the area of the interior rear-view mirror detects traffic signs at the edge of the road as well as variable overhead sign posts. Traffic signs with additional symbols, for example, when wet, are also compared with data internal to the vehicle, for example the rain sensor, and displayed, depending on the situation. The system considers the information saved in the navigation system and also displays the

speed limits present on unmarked sections of road.

## No Passing Information

No Passing Information displays with corresponding symbols in the instrument cluster no passing restrictions and their removal detected by the camera. The system only considers no passing restrictions and lifting the restriction made known by signage.

Nothing will be displayed in the following situations:

- ▷ In countries in which no passing is primarily shown by road markings.
- ▷ On routes without signage.
- ▷ On railway crossings, lane markings or in other situations which would not indicate an unsigned no passing restriction.

## Notes



### WARNING

The system does not take your personal responsibility from you when you are estimating the visibility conditions and traffic situation. Danger of accidents. Adapt driving style to the driving conditions. Observe the traffic situation and intervene actively if the situation warrants it. ◀

## Overview

### Camera

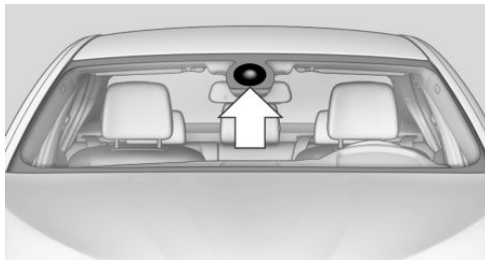

The camera is in the area of the base of the rear-view mirror.

Keep the windscreen clean and clear in the area in front of the rear view mirror.

## Switching on/off

On the Control Display:

1. "Settings"
2. "Instr. cluster display"
3. "Limit info"

If Speed Limit Information is switched on, this can be displayed through the on-board computer on the information display in the instrument cluster.

No Passing Information is displayed together with activated Speed Limit information.

## Display

The following appears in the instrument cluster:

### Speed Limit Information

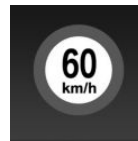

Present speed limit.

Speed limit cancelled - for German motorways.

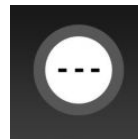

Speed limit information unavailable.

The Speed Limit Information can also be displayed in the Head-Up Display.

### No Passing Information



- ▷ No passing restriction.
- ▷ End of no passing restriction.
- ▷ No Passing Information unavailable.

The No Passing Information can also be shown in the Head-Up Display.

## System limits

The function may be disabled or inaccurate under certain conditions, for example:

- ▷ In thick fog and heavy rain or snow.
- ▷ If road signs are obscured by objects.
- ▷ If the vehicle is moving too close to the vehicle ahead.
- ▷ With bright oncoming light.
- ▷ When the windscreen in front of the rear-view mirror is covered with condensation, dirt, stickers, etc.
- ▷ Due to possible wrong detections of the camera.
- ▷ If the speed limits saved in the navigation system are wrong.
- ▷ In areas not covered by the navigation system.
- ▷ If there are deviations in relation to the navigation, for example due to changes in the road routing.
- ▷ On overtaking buses or trucks with speed stickers.
- ▷ If traffic signs do not correspond to the standard.
- ▷ During the calibration process of the camera immediately after the vehicle is supplied.

## Selection lists in the instrument cluster

### Principle

Depending on equipment, the following can be displayed or operated via the buttons and the knurled wheel on the steering wheel and using the displays in the instrument cluster and Head-Up Display:

- ▷ Current audio source.
- ▷ Repeat dialling for telephone.
- ▷ Activating the voice control system.

## Display

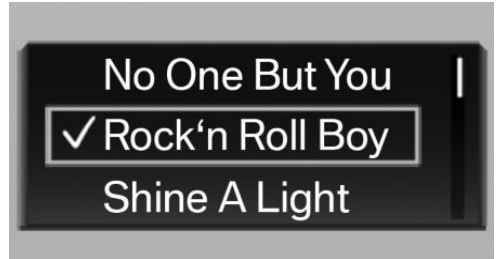

Depending on equipment, the list in the instrument cluster may differ from what is displayed.

### Activating the list and entering a setting

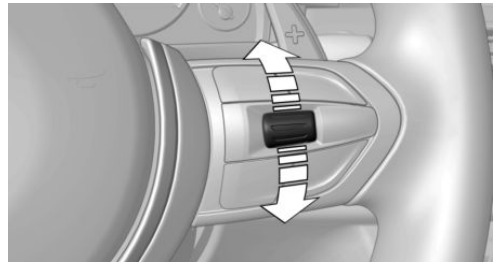

Turn the knurled wheel on the right-hand side of the steering wheel to activate the corresponding list.

Using the knurled wheel, select the desired setting and confirm by pressing the knurled wheel.

## On-board computer

### Display in the information display

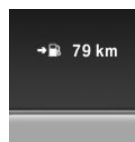

The information from the on-board computer is displayed in the information display in the instrument cluster.

## Calling up information on the information display

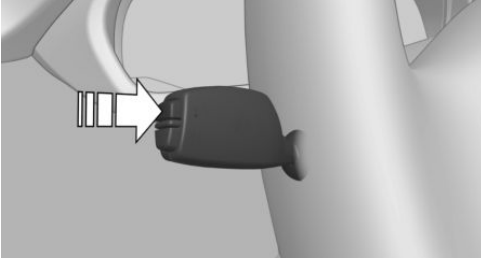

Press the button on turn indicator lever. Information is displayed on the information display in the instrument cluster.

### Overview of the information

Repeated pressing of the button on the turn indicator lever shows the following information on the information display:

- ▷ Range.
- ▷ Average consumption, fuel
- ▷ Momentary consumption, fuel.
- ▷ Average speed.
- ▷ Date.
- ▷ Speed Limit Information.
- ▷ Time of arrival.
  - With activated route guidance in the navigation system.
- ▷ Distance to destination.
  - With activated route guidance in the navigation system.
- ▷ Outside temperature and date.
  - When the digital speedometer is activated.

### Setting displays for the information display

Depending on the equipment, it can be set which displays of the on-board computer can be called up on the information display in the instrument cluster.

On the Control Display:

1. "Settings"
2. "Instr. cluster display"
3. Select the desired displays.

### Detailed information

#### Range

Displays the estimated range available with the remaining fuel.

It is calculated based on your driving style over the last 30 km, 20 miles.

#### Average fuel consumption

The average consumption is calculated for the period during which the engine is running.

The average consumption is calculated on the route travelled since the on-board computer was last reset.

#### Average speed

The calculation of average speed ignores any stationary periods where the engine was switched off manually.

### Resetting average values

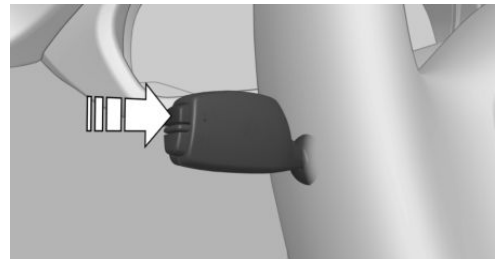

Keep the button pressed on the turn indicator lever.

#### Distance to destination

The remaining distance to the destination is displayed if a destination was entered in the

navigation system before the start of the journey.

The distance to the destination is automatically adopted.

### Arrival time

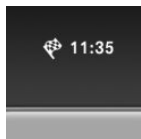

The estimated time of arrival is displayed if a destination was entered in the navigation system before the start of the journey.

A precondition is that the time is correctly set.

### Speed Limit Information

Description of Speed Limit Information, see page 88.

### Journey computer

Two types of on-board computer are available.

- ▷ "On-board computer": values can be reset any number of times.
- ▷ "Trip computer": values deliver an overview of the current trip.

### Resetting the journey computer

On the Control Display:

1. "Vehicle information"
2. "Trip computer"
3. "Reset": all values are reset.  
"Reset automatically": all values are reset if the vehicle is at a standstill for approximately four hours.

### Display on the Control Display

Display the on-board computer or journey computer on the Control Display.

1. "Vehicle information"
2. "On-board computer" or "Trip computer"

### Resetting fuel consumption or speed

On the Control Display:

1. "Vehicle information"
2. "On-board computer"
3. "Consumpt." or "Speed"
4. "Yes"

## Sport displays

### Principle

On the Control Display the current values for power and torque are shown with the relevant equipment.

### Show Sport displays on the Control Display

1. "Vehicle information"
2. "Sport displays"

## Speed warning

### Principle

Display of a speed at which a warning is to be issued when reached.

Repeat warning if the set speed limit was undershot once by at least 5 km/h/3 mph.

### Displaying, setting or altering the speed warning

On the Control Display:

1. "Settings"
2. "Speed"
3. "Warning at:"
4. Turn the Controller until the desired speed is displayed.
5. Press the Controller.  
Speed warning is stored.

## Activating/deactivating speed warning

On the Control Display:

1. "Settings"
2. "Speed"
3. "Warning"
4. Press the Controller.

## Saving actual speed as speed warning

On the Control Display:

1. "Settings"
2. "Speed"
3. "Select current speed"
4. Press the Controller.  
The current driving speed is saved as the speed warning.

## Settings on the control display

### Time

#### Setting the time zone

1. "Settings"
2. "Time/date"
3. "Time zone:"
4. Select desired time zone.

The time zone is saved.

#### Setting the time

1. "Settings"
2. "Time/date"
3. "Time:"
4. Turn the controller until the desired hours are displayed.
5. Press the controller.
6. Turn the controller until the desired minutes are displayed.
7. Press the controller.

The time is saved.

#### Setting the time format

1. "Settings"
2. "Time/date"
3. "Format:"
4. Select the desired format.

The time format is saved.

#### Automatic time setting

Depending on equipment, the time, date and, if necessary, time zone are updated automatically.

1. "Settings"
2. "Time/date"
3. "Automatic time setting"

### Date

#### Setting the date

1. "Settings"
2. "Time/date"
3. "Date:"
4. Turn the controller until the desired day is displayed.
5. Press the controller.
6. Make the setting for month and year accordingly.

The date is saved.

#### Setting the date format

1. "Settings"
2. "Time/date"
3. "Format:"
4. Select the desired format.

The date format is saved.

## Language

### Setting the language

To set the language on the Control Display:

1. "Settings"
2. "Language/units"
3. "Language:"
4. Select the desired language.

The setting is stored for the currently used profile.

### Setting the speech dialogue

Voice dialogue for the voice control system, see page 26.

## Units of measure

### Setting the units of measure

To set the units of measure for fuel consumption, distance covered/remaining range, and temperature:

1. "Settings"
2. "Language/units"
3. Select the desired menu item.
4. Select the desired unit.

The setting is stored for the currently used profile.

## Brightness

### Adjusting brightness

Adjusting brightness of Control Display:

1. "Settings"
2. "Control display"
3. "Brightness"
4. Turn the Controller until the desired brightness is obtained.
5. Press the Controller.

The setting is stored for the currently used profile.

Depending on the lighting conditions, brightness control might not be immediately recognisable.

## Head-Up Display

### Overview

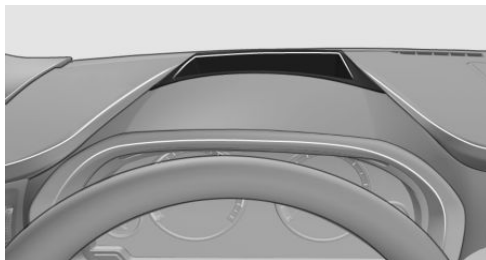

### Principle

The system projects important information into the field of vision of the driver, for example speed.

The driver can register this information without having to divert attention from the road.

### Notes

Follow information on cleaning the Head-Up Display, see page 211.

### Visibility of the display

Visibility of the display on the Head-Up Display is influenced by the following factors:

- ▷ Certain seat positions.
- ▷ Items on the Head-Up Display cover.
- ▷ Sunglasses with certain polarisation filters.
- ▷ Wet road.
- ▷ Unfavourable lighting conditions.

If the picture is distorted, have the basic settings checked by a Service Partner or a qualified specialist workshop.

## Switching on/off

1. "Settings"
2. "Head-up display"
3. "Head-up display"

## Display

### Standard view

The following information is displayed in the Head-Up Display:

- Speed.
- Navigation system.
- Check Control messages.
- Selection list from the instrument cluster.
- Driver Assistance Systems.

Some of this information is only shown briefly when needed.

### M View



- 1 Current engine speed, highlighted
- 2 Shift Lights
- 3 Forewarning field, engine speed display
- 4 Red warning field, engine speed display
- 5 Speed
- 6 Gear display/warning messages
- 7 Speed Limit Information with No Passing Information

Activate M View:

Select displays in the head-up display.

## Selecting displays on the Head-Up Display

On the Control Display:

1. "Settings"
2. "Head-up display"
3. "Information displayed"
4. Select desired display on Head-Up Display.

## Adjusting brightness

The brightness is automatically adapted to the ambient light.

The base setting can be adjusted manually.

On the Control Display:

1. "Settings"
2. "Head-up display"
3. "Brightness"
4. Turn the Controller until the desired brightness is obtained.
5. Press the Controller.

The brightness of the Head-Up Display can also be influenced using the instrument lighting if the low-beam headlights are switched on.

The setting is saved for the currently used profile.

## Adjusting height

On the Control Display:

1. "Settings"
2. "Head-up display"
3. "Height"
4. Turn the Controller until the desired height is obtained.
5. Press the Controller.

The setting is saved for the currently used profile.

## Adjusting rotation

The image of the Head-Up Display can be rotated around its axis.

On the Control Display:

1. "Settings"
2. "Head-up display"
3. "Rotation"
4. Turn the Controller until the desired setting is reached.
5. Press the Controller.

The setting is saved for the currently used profile.

## Special windscreen

The windscreen constitutes part of the system.

The shape of the windscreen enables a precise projection.

A film in the windscreen prevents double images occurring.

For this reason, have the special windscreen replaced by a Service Partner or a qualified specialist workshop.

## Shift Lights

### General

The display is on the Head-Up Display and in the instrument cluster.

## Shift Lights in the instrument cluster

### Display

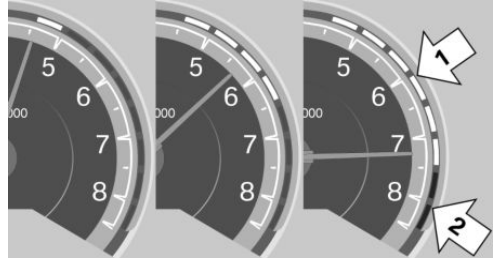

- ▶ Current engine speed is shown in the revolution counter.
- ▶ Arrow 1: yellow buttons illuminating successively indicate when an upshift is due.
- ▶ Arrow 2: buttons illuminate red. Shift then at the latest.

When the maximum permitted engine speed is reached, the entire display flashes.

When the maximum engine speed is exceeded, the fuel supply is limited to protect the engine.

## Shift Lights on the Head-Up Display

### Switching on

Shift Lights are only displayed on the Head-Up Display in M view, see page 95.

1. Switch on Head-Up Display, see page 95.
2. "Settings"
3. "Head-up display"
4. "Information displayed"
5. "M View"

## Display

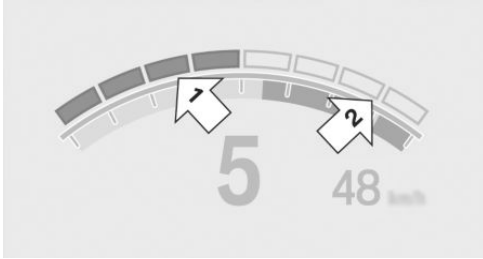

- ▶ Current engine speed is shown in the revolution counter.
- ▶ Arrow 1: yellow buttons illuminating successively indicate when an upshift is due.
- ▶ Arrow 2: buttons illuminate red. Shift then at the latest.

When the maximum permitted engine speed is reached, the entire display flashes.

When the maximum engine speed is exceeded, the fuel supply is limited to protect the engine.

# Lights

## Vehicle equipment

This chapter describes all standard, national and special equipment provided in the model series. Equipment not available in the vehicle is therefore also described, for example the selected special equipment or national version. This also applies to safety-relevant functions and systems. Comply with the relevant national regulations when using the corresponding functions and systems.



## Overview



### Switch in the vehicle



The light switch element is located next to the steering wheel.



### Light functions

Symbol	Function
	Rear fog lights
	Automatic driving lights control Adaptive Headlights
	Lights off Daytime driving lights

Symbol	Function
	Side lights
	Low-beam headlights
	Instrument lighting

## Side lights, low-beam headlights and parking light

### General

Switch position: 0, , 

If the driver's door is opened with the ignition switched off, the exterior lights are automatically switched off with these switch settings.

### Side lights

Switch position: 

The vehicle is illuminated all round.

You should not leave the side lights on for longer periods of time, since the vehicle battery could discharge and you might not have enough power to start the engine.

To park, switch on the one-sided parking light, see page 99.

### Low-beam headlights

Switch position: 

The low-beam headlights illuminate with the ignition switched on.

## Parking lights

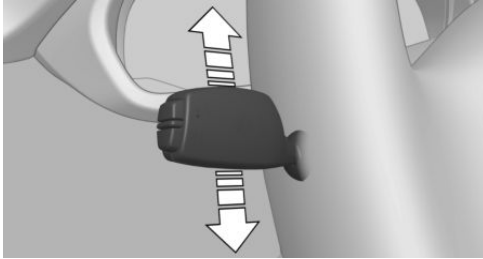

The vehicle can be illuminated on one side.

### Switching on



With the ignition switched off, push the lever upwards or downwards beyond the resistance point for approximately 2 seconds.

### Switching off

Press the lever briefly in the opposite direction as far as the resistance point.

## Welcome lights and headlight courtesy delay feature

### Welcome lights

Depending on the equipment version, switch position  or  when parking the vehicle.

Depending on the ambient brightness, the side lights and interior light may come on briefly when unlocking the vehicle.

### Activating/deactivating

On the Control Display:

1. "Settings"
2. "Lights"
3. "Welcome light"

The setting is saved for the currently used profile.

## Headlight courtesy delay feature

If the headlight flasher is activated after switching off the radio ready state, the low-beam headlights illuminate and remain on for a certain amount of time.

### Setting the duration

On the Control Display:

1. "Settings"
2. "Lights"
3. "Home lights:"
4. Set the duration.

The setting is saved for the currently used profile.

## Automatic driving lights control

### Principle

Depending on ambient brightness, the system switches the low-beam headlights on or off automatically, for example in a tunnel, at twilight and in rain or snow.

### General

The headlights may also come on when the sun is sitting low in a blue sky.

When emerging from tunnels in daylight, low-beam headlights are not switched off immediately, but only after approximately 2 minutes.

The low-beam headlights always remain on when the fog lights are switched on.

### Activating

Switch position: 

The indicator light in the instrument cluster is illuminated with the low-beam headlights switched on.

## System limits

The automatic driving lights control is no substitute for your individual judgement of when it is necessary to switch on the lights.

The sensors are unable, for instance, to recognise fog or hazy weather. In such situations, switch on the lights manually to avoid any safety risk.

## Daytime driving lights

Switch position: 0, 

The daytime driving lights illuminate with the ignition switched on.

### Activating/deactivating

In some countries daytime driving lights are compulsory, which is why the daytime driving lights cannot be deactivated.

On the Control Display:

1. "Settings"
2. "Lights"
3. "Daytime driving lights"

The setting is saved for the currently used profile.

## Adaptive Headlights

### Principle

Adaptive Headlights is a variable headlight control system that makes it possible to illuminate the road surface responsively.

The beams from the headlights follow the road ahead on the basis of the steering angle and other parameters.

Depending on the speed, the variable light distribution ensures even better illumination of the roadway.

The light distribution is automatically adapted to the speed. The city light is switched on if the speed of 50 km/h, approx. 30 mph is not ex-

ceeded while accelerating or if the speed of 40 km/h, approx. 25 mph is undercut while braking. The motorway light is switched on at a speed higher than 110 km/h, 68 mph after approximately 30 seconds or as of a speed of 140 km/h, 87 mph.

### Activating

Switch position  with the ignition switched on.

So as not to dazzle oncoming vehicles, the adaptive cornering light does not swivel to the driver's side when stationary.

A cornering light is activated automatically depending on the steering angle or use of the turn indicators.

The cornering light may be switched on when driving in reverse, irrespective of the steering angle.

### Malfunction

A Check Control message is displayed.

Adaptive Headlights are faulty or have failed. Have the system checked as soon as possible.



## High-beam assistance

### Principle

When low-beam headlights are switched on, this system automatically switches the high-beam headlights on and off or fades out the areas which dazzle oncoming vehicles. This process is controlled by a camera on the front of the rear-view mirror. It ensures that the high-beam headlights are switched on whenever the traffic situation allows. You can also control the lights yourself at any time and switch them on and off as usual. The high-beam headlights are not switched on by the system in the low speed range.

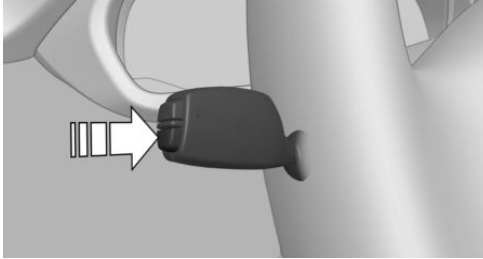
## Activating



1. Depending on equipment, turn the light switch to position  or .
2. Press the button on the turn indicator lever, arrow.



The indicator light in the instrument cluster is illuminated.

When the low-beam headlights are on, the beam is dipped and returned to full beam automatically.

The system responds to light from oncoming traffic and traffic driving ahead of you, and to adequate lighting, for example in built-up areas.



The blue indicator light in the instrument cluster illuminates if the high beam is switched on by the system.

Depending on the version of the system installed in the vehicle, the high-beam lights may not be switched off for oncoming vehicles, but only the areas which dazzle the oncoming vehicles are faded out. In this case, the blue indicator light continues to illuminate.

## Raising and dipping manually

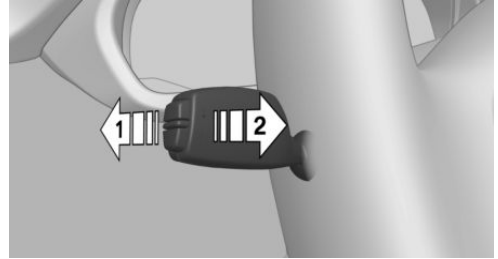

- ▷ High-beam headlights on, arrow 1.
- ▷ High-beam headlights off/headlight flasher, arrow 2.

The high beam assistance can be deactivated by manually raising and dipping.

To reactivate high-beam assistance, press the button on the turn indicator lever, see page 101.

### System limits

The high-beam assistance cannot replace the personal decision to use the high-beam headlights. Thus, dip manually in situations requiring such.

In the following situations, the system will not operate or its operation will be impaired and your intervention may be required:

- ▷ During extremely unfavourable weather conditions such as fog or heavy precipitation.
- ▷ When detecting poorly-lit road users such as pedestrians, cyclists or horseback riders or carts, and when trains or ships are close to the road, or when game are passing across the road.
- ▷ On narrow bends, steep uphill or downhill gradients, at traffic junctions or if your view of oncoming vehicles on a motorway is obstructed.
- ▷ In poorly-lit towns and where there are very reflective signs.

- ▶ When the windscreen in front of the rear-view mirror is covered with condensation, dirt, stickers, labels, etc.

## Fog lights

### Rear fog lights

The low-beam headlights must be switched on.

 Press the button. The yellow indicator light is illuminated.

If automatic driving lights control, see page 99, has been activated, the low-beam headlights come on automatically when the rear fog lights are switched on.

## Left-hand/right-hand traffic

### General

When driving in countries where the opposite rule of the road applies, you need to prevent your headlights from dazzling oncoming vehicles.

### Xenon headlight

Light distribution of the headlights avoids dazzling of the low-beam headlights when driving in a country in which the traffic drives on the opposite side.

### Adaptive Headlights

When driving in a country where you drive on the opposite side of the road from the country the vehicle is licensed, do not drive with the  setting, otherwise this could cause a dazzling effect from the variable light distribution.

### LED headlights

The Service Partner or a qualified specialist workshop has light benders available. Proceed in accordance with the enclosed information

when affixing the light benders to the headlights.

### Adaptive Headlights

When driving in a country where you drive on the opposite side of the road from the country the vehicle is licensed, do not drive with the  setting, otherwise this could cause a dazzling effect from the variable light distribution.

## Instrument lighting

### Adjusting



The brightness can only be adjusted when the side lights or the low-beam headlights are switched on.

The brightness can be set using the knurled wheel.

## Interior light

### General

The interior light, the footwell lights, door entry lighting and the courtesy lighting are controlled automatically.

The brightness of some equipment is influenced by the knurled wheel for the instrument lighting.

## Overview



- 1 Interior light
- 2 Reading light

## Switching the interior light on and off manually



Press the button.

To switch off permanently: press the button for approximately three seconds.

Switch on again: press button.

## Reading lights



Press the button.

There are reading lights located at the front and in the rear beside the interior lights.

## Ambient lighting

Depending on the equipment, the lighting in the interior can be set for a few lights.

## Selecting colour scheme

On the Control Display:

1. "Settings"
2. "Lights"
3. "Ambient:"
4. Select the desired setting.

## Adjusting brightness

The brightness of the ambient light can be set over the knurled wheel for the instrument lighting or on the Control Display.

On the Control Display:

1. "Settings"
2. "Lights"
3. "Brightness:"
4. Adjusting brightness.

# Security

## Vehicle equipment

This chapter describes all standard, national and special equipment provided in the model series. Equipment not available in the vehicle is therefore also described, for example the se-

lected special equipment or national version. This also applies to safety-relevant functions and systems. Comply with the relevant national regulations when using the corresponding functions and systems.

## Airbags

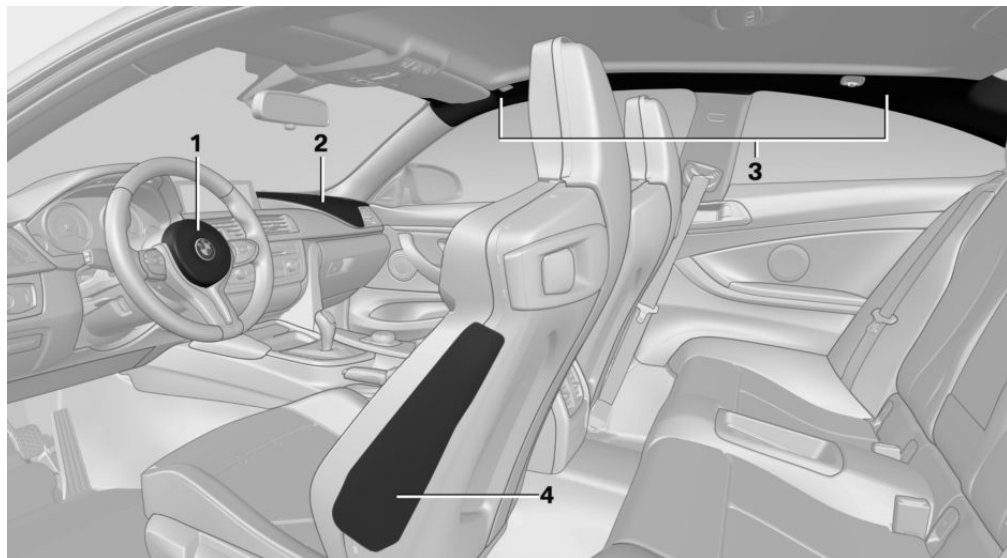

1 Front airbag, driver

2 Front airbag, front passenger

3 Head airbag

4 Side airbag

### Front airbags

Front airbags protect the driver and front passenger in the event of a head-on collision where the action of the seat belts alone would be insufficient.

### Side airbag

In a side-on crash, the side airbag supports the body from the side in the chest and pelvic area.

### Head airbag

The head airbag supports the head in the event of a side-on collision.

### Protective effect

Airbags are not activated by every collision, for example in minor accidents and rear-end collisions.

## Notes on optimum protective effect of the airbag

### WARNING

If the seat position is wrong or the deployment area of the airbag is impaired, the airbag system cannot provide the intended protection, or may cause additional injuries when it deploys. Danger of injury or life. Comply with these notes for optimum protective effect. ◀

- ▶ Keep your distance from the airbags.
- ▶ Make sure that vehicle occupants keep their head away from the side airbag.
- ▶ Always grip the steering wheel on the steering wheel rim. Keep your hands in the 3 o'clock and 9 o'clock positions to reduce the risk of injury to hands or arms when the airbag deploys.
- ▶ Make sure that the front-seat passenger is sitting correctly, in other words with feet or legs in the footwell, not resting on the dashboard.
- ▶ Do not position any other persons, pets or objects between the airbags and persons.
- ▶ Never attach any material to the airbag covers with adhesive; never place material over them or modify them in any way.
- ▶ Keep the dashboard and windscreen in the area of the passenger's side free, for example do not attach adhesive foil or covers and do not fit brackets for navigation devices or mobile telephones.
- ▶ Do not use the front airbag cover on the front passenger's side as a tray.
- ▶ Do not fit seat covers, cushions or other objects not specifically suitable for seats with integral side airbags to the front seats.
- ▶ Do not hang items of clothing such as coats or jackets over the backrests.
- ▶ Do not modify individual components of the system or its wiring in any way. This also applies to the covers of the steering wheel, the dashboard and seats.

- ▶ Do not dismantle the airbag system.

Even if all these notes are complied with, depending on the circumstances in which an accident occurs, certain injuries as a result of contact with the airbag cannot be entirely ruled out.

The noise caused by the deployment of an airbag may lead to temporary hearing loss for vehicle occupants sensitive to noise.

## Operational readiness of the airbag system

### Notes

#### WARNING

Individual components of the airbag system can be hot after triggering. Danger of injury. Do not touch individual components. ◀

#### WARNING

Work carried out incorrectly can lead to a failure, a malfunction or accidental triggering of the airbag system. If there is a malfunction, the airbag system might not trigger as intended in an accident, in spite of the accident being of the appropriate severity. Danger of injury or life. Have the airbag system tested, repaired or removed and scrapped by a Service Partner or a qualified specialist workshop. ◀

## Correct function



When the ignition is switched on, the warning light in the instrument cluster briefly illuminates in order to show the functional readiness of the entire airbag system and the belt tensioner.

## Airbag system disrupted

- ▶ Warning light does not illuminate after the ignition is switched on.
- ▶ Warning lamp is permanently illuminated.

## Not for Australia/New Zealand: Key switch for front passenger airbags

### General

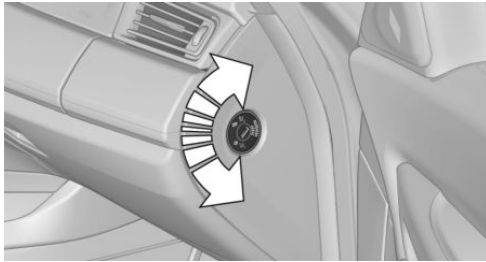

The front and side airbags for the front passenger can be deactivated and reactivated using the integrated key from the remote control.

### Deactivating the front passenger airbags



1. Insert the key and press inwards where necessary.
2. While the key is pressed inwards, turn it to the OFF position as far as it will go. Once the stop position has been reached, remove the key.
3. Make sure that the key switch is in the corresponding end position so that the airbags are deactivated.

The front passenger airbags are deactivated. The driver's airbags remain active.

If a child restraint system is no longer fitted in the front passenger seat, reactivate the front passenger airbags so that they are triggered as intended in the event of an accident.

The airbag condition is displayed on the indicator light on the roof lining, see page 106.

### Activating the front passenger airbags



1. Insert the key and press inwards where necessary.
2. While the key is pressed inwards, turn it to the ON position as far as it will go. Once the stop position has been reached, remove the key.
3. Make sure that the key switch is in the corresponding end position so that the airbags are activated.

The front passenger airbags are reactivated and can deploy correctly if the need arises.

### Indicator light for front passenger airbags



The indicator light for the front passenger airbags shows the operating status of the front passenger airbags.

After switching on the ignition, the light illuminates briefly and then shows whether the airbags are activated or deactivated.



- ▶ When front passenger airbags are deactivated, the indicator light remains illuminated.
- ▶ When front passenger airbags are activated, the indicator light is not illuminated.

## Tyre Pressure Monitor TPM

### Principle

The system monitors the tyre pressure in the four fitted tyres. The system warns if the inflation pressure in one or more tyres has fallen considerably. To do this, the sensors in the tyre valves measure the tyre pressure and tyre temperatures.

### Note

To operate the system, also follow the other information and notes under tyre inflation pressure, see page 175.

### Operating requirements

For the system, a reset must have been made with the correct tyre inflation pressure, otherwise reliable signalling of a flat tyre cannot be assured.

Reset the system after adjusting the tyre pressure to a new value and after a tyre or wheel change.

Always use wheels with TPM electronics to guarantee the system functions without errors.

### Status display

The current status of the Tyre Pressure Monitor TPM can be shown on the Control Display, for example whether the TPM is active.

On the Control Display:

1. "Vehicle information"
2. "Vehicle status"
3.  "Tyre Pressure Monitor (RDC)"

The status is displayed.

### Status control display

The tyre and system status is denoted by the wheel colour and some text on the Control Display.

### All wheels green

System is active and is warning about the tyre inflation pressures stored during the last reset.

### One wheel yellow

A flat tyre or major loss of tyre inflation pressure in the tyre shown.

### All wheels yellow

A flat tyre or major loss of tyre inflation pressure in several tyres.

### Wheels grey

The system cannot detect a flat tyre. The reasons for this are:

- ▷ System reset is performed.
- ▷ Malfunction.

### Additional information

The current tyre inflation pressures and, depending on the model, tyre temperatures are also displayed in the status control display. The values shown are current values and may change due to the effect of driving mode or weather conditions.

### Running reset

Reset the system after adjusting the tyre pressure to a new value and after a tyre or wheel change.

On the Control Display and on the vehicle:

1. "Vehicle information"
2. "Vehicle status"
3.  "Perform reset"
4. Start the engine – do not drive off.
5. Resetting tyre pressure: "Perform reset".
6. Drive off.

The wheels are shown grey and the status appears on the display.

After driving for a short time over 30 km/h, 19 mph the set tyre inflation pressures are ac-

cepted as target values. The reset is run automatically while the vehicle is in motion.

After a successfully concluded reset, the wheels are shown in green on the Control Display and "Tyre Pressure Monitor (RDC) active." is shown.

You can interrupt your drive at any time. Reset resumes automatically when you continue your journey.

### Message if tyre inflation pressure is low



The yellow warning lamp is illuminated. A Check Control message is shown.

- ▷ There is a flat tyre or substantial loss of tyre pressure.
  - ▷ No reset has been done to the system. Consequently, the system warns of the tyre pressures of the last reset.
1. Reduce your speed and carefully stop the vehicle. Avoid violent or sudden braking and steering manoeuvres.
  2. Determine which wheel is damaged. Do this by checking the tyre inflation pressures with the aid of the Mobility System. Correcting the tyre inflation pressure
  3. Remedy the flat tyre with the Mobility System or replace the damaged wheel.

When there is a message that the tyre inflation pressure is low, the Dynamic Stability Control DSC may be switched on.

### Message with required tyre inflation pressure test

In such situations, a check control message is displayed:

- ▷ System has detected a wheel change, but no reset has been run.
- ▷ Filling was not performed according to the regulations.
- ▷ The tyre inflation pressure has dropped compared to the last confirmation.

If that is the case:

- ▷ Check the tyre pressure and adjust as necessary.
- ▷ Reset the system after a wheel change.

### System limits

The system is not working correctly if no reset has been run, for example, a flat tyre is reported in spite of the correct tyre inflation pressure.

Tyre inflation pressure depends on the temperature of the tyre. By increasing tyre temperature, for example, when driving or with solar radiation, the tyre inflation pressure increases. Tyre inflation pressure decreases if the tyre temperature drops. Through this behaviour, a warning may be triggered if there are major temperature drops, due to the given warning limits.

No warning can be given by the system of extreme, sudden tyre failure caused by external factors.

### Malfunction



The yellow warning lamp flashes and is then illuminated continuously. A Check Control message is shown. No flat

tyres or loss of tyre pressure can be detected.

This may indicate one of the following:

- ▷ Wheel without TPM electronics is fitted: have the vehicle checked by a Service Partner or a qualified specialist workshop if necessary.
- ▷ Malfunction: have the system checked by a Service Partner or a qualified specialist workshop.
- ▷ TPM has not completed a reset. Run a reset of the system again.
- ▷ Fault due to systems or devices with the same frequency: the system is automatically reactivated upon leaving the field of interference.

## Runflat indicator RPA

### Principle

The system identifies a loss of tyre pressure by comparing the speeds of rotation of the individual wheels while the vehicle is in motion. If a tyre loses pressure, its diameter changes. This in turn alters the rotational speed of the corresponding wheel. This is detected and reported as a flat tyre.

The system does not measure the tyre pressures as such.

### Operating requirements

The system must have been initialised with correct tyre inflation pressure, otherwise reliable signalling of a flat tyre cannot be assured. Each time the tyre pressure is adjusted or a tyre or wheel is changed, initialise the system again.

### Status display

The current status of the runflat indicator can be shown on the Control Display, for example whether the runflat indicator is active.

On the Control Display:

1. "Vehicle information"
2. "Vehicle status"
3.  "Flat Tyre Monitor (RPA)"

The status is displayed.

### Initialising

On initialisation, the current tyre pressures are stored as a reference for detection of a flat tyre. The initialisation is started by confirming the correct tyre inflation pressures.

When driving with snow chains fitted, do not initialise the system.

On the Control Display:

1. "Vehicle information"
2. "Vehicle status"

3.  "Perform reset"
4. Start the engine – do not drive off.
5. Start the initialisation with "Perform reset".
6. Drive off.

Initialising is completed while the vehicle is in motion; this process can be interrupted at any time.

Initialising resumes automatically when you continue your journey.

### Message of a flat tyre



The yellow warning lamp is illuminated. A Check Control message is shown.

There is a flat tyre or substantial loss of tyre pressure.

1. Reduce your speed and carefully stop the vehicle. Avoid violent or sudden braking and steering manoeuvres.
2. Determine which wheel is damaged. Do this by checking the tyre inflation pressures with the aid of the Mobility System. If all tyres are inflated to the correct pressures, the runflat indicator might not have been initialised. In this case initialise the system.
3. Remedy the flat tyre with the Mobility System or replace the damaged wheel.

### System limits

A natural, even loss of tyre pressure in all four tyres that occurs over time is not detected. Consequently, check the tyre inflation pressure at regular intervals.

No warning can be given in the event of sudden tyre failure caused by external factors.

In the following situations, the system could be slow to respond or operate incorrectly:

- ▶ If the system has not been initialised.
- ▶ Journey on snow-covered or slippery surfaces.

- ▷ Dynamic driving style, causing the drive gears to spin, high lateral acceleration.
- ▷ Driving with snow chains.

## Intelligent Safety

### Principle

Intelligent Safety permits central operation of driver assistance systems.

Depending on equipment, Intelligent Safety consists of one or more systems which can help to avoid the risk of a collision. These systems are automatically active each time you start the engine with the start/stop button:

- ▷ Front-end collision warning with city braking function, see page 111.
- ▷ Person warning, see page 113.

### Notes

#### WARNING

Displays and warnings do not take your personal responsibility from you. System limitations can mean that warnings or system responses are not issued, are issued too late, or are issued incorrectly. Danger of accidents. Adapt driving style to the driving conditions. Observe the traffic situation and intervene actively if the situation warrants it. ◀

#### WARNING

Due to system limitations, there may be malfunctions of individual functions when tow-starting/towing with activated Intelligent Safety Systems, for example approach control warning with light braking function. Danger of accidents. Switch off all Intelligent Safety Systems before tow-starting/towing. ◀

## Overview

### Button in the vehicle



Intelligent Safety button

### Camera

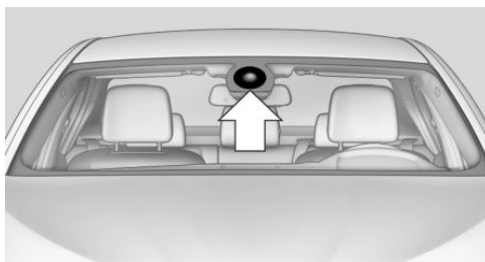

The camera is in the area of the base of the rear-view mirror.

Keep the windscreen clean and clear in the area in front of the rear view mirror.

### Switching on/off

The Intelligent Safety Systems are active automatically at the start of each journey.



Press button: the systems are switched off again. LED turns off.

Press button again: the systems are switched on. LED is illuminated.

Settings can be adjusted on the Control Display.

## Front-end collision warning with city braking function

### Principle

The system can help avoid accidents. If an accident cannot be avoided, the system helps to reduce the collision speed.

The system warns of the possible risk of collision and brakes automatically, as necessary.

The automatic braking intervention is done with limited force and duration.

The system is controlled by a camera in the area of the rear-view mirror.

The front-end collision warning is also available if the Cruise Control is disabled.

When deliberately approaching a vehicle, the approach control warning and braking intervention are activated later to avoid unjustified system responses.

### General

The system warns from approximately 5 km/h, approximately 3 mph in two stages of any risk of collision with vehicles. The timing of these warnings may vary depending on the current driving situation.

Up to approximately 60km/h, 35 mph.

### Detection range

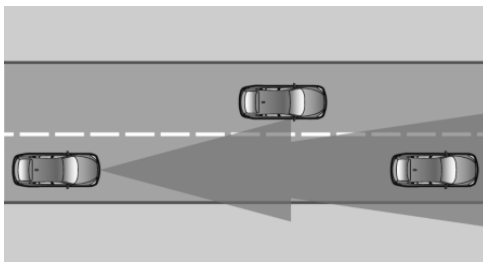

Objects are taken into account if they are detected by the system.

### Notes



#### WARNING

Displays and warnings do not take your personal responsibility from you. System limitations can mean that warnings or system responses are not issued, are issued too late, or are issued incorrectly. Danger of accidents. Adapt driving style to the driving conditions. Observe the traffic situation and intervene actively if the situation warrants it. ◀



#### WARNING

Due to system limitations, there may be malfunctions of individual functions when tow-starting/towing with activated Intelligent Safety Systems, for example approach control warning with light braking function. Danger of accidents. Switch off all Intelligent Safety Systems before tow-starting/towing. ◀

### Overview

#### Button in the vehicle



Intelligent Safety button

## Camera

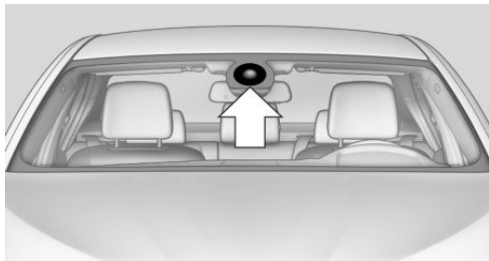

The camera is in the area of the base of the rear-view mirror.

Keep the windscreen clean and clear in the area in front of the rear view mirror.

## Switching on/off

### Automatic activation

The system is automatically activated at the start of each journey.

### Switching off



Press the button: the system is switched off. LED turns off.

Press the button again: the system is switched on. LED is illuminated.

### Setting warning time

The warning time can be set using iDrive.

1. "Settings"
2. "Collision warning"
3. Set the desired time on the Control Display.

The selected time is stored for the currently used profile.

## Warning with braking function

### Display

If there is a risk of collision with a detected vehicle, a warning symbol is shown in the instrument cluster and in the Head-Up Display.

Symbol	Measure
	Symbol illuminates red: advance warning. Increase braking and distance.
	Symbol flashes red and an acoustic signal sounds: acute warning. System indicates that you must brake and/or manoeuvre the vehicle yourself.



### Advance warning

An advance warning is shown, for example if a danger of collision is anticipated or there is a very short distance to a vehicle ahead.

The driver must intervene personally if there is an advance warning.

### Acute warning with braking function

An acute warning is shown in the event of an immediate collision if the vehicle approaches an object with relatively high differential speed.

The driver must intervene personally if there is an acute warning. If necessary, the driver is assisted by slight automatic brake intervention if there is a risk of collision.

An acute warning can be triggered even without a previous advance warning.

### Brake intervention

The warning requires to take action yourself. Maximum braking force is used during a warning. In order for braking force support to be used, it is necessary for the brake to be pressed sufficiently quickly and powerfully. In addition, the system may also support with a small amount of braking if there is the risk of a

collision. The vehicle can be braked at low speed until it comes to a stop.

Manual gearbox: When brakes are engaged until it comes to a stop, the engine may shut off.

There will only be brake intervention if Dynamic Stability Control, DSC is activated and M Dynamic Mode MDM is not activated.

Braking can be discontinued either by pressing the accelerator pedal or by actively moving the steering wheel.

Detection of objects can be restricted. Limitations of the detection range and functional restrictions are to be considered.

## System limits

### Detection range

The detection ability of the system is limited.

For this reason, system responses may be missing or delayed.

It is possible that the following are not detected:

- ▶ Slow-moving vehicle when approaching at high speed.
- ▶ Vehicles suddenly cutting in or decelerating heavily.
- ▶ Vehicles with unusual rear view.
- ▶ Two-wheeled vehicles ahead.

### Restrictions of the function

The function can be restricted, for example in the following situations:

- ▶ In thick fog, rain, spray or snowfall.
- ▶ On sharp bends.
- ▶ When restricting or deactivating vehicle stability control systems, for example DSC OFF.
- ▶ If the field of view of the camera in the mirror is soiled or covered.

- ▶ Up to 10 seconds after starting the engine using the start/stop button.
- ▶ During the calibration process of the camera immediately after the vehicle is supplied.
- ▶ When there is sustained glare effect due to light opposite, for example the sun low in the sky.

## Sensitivity of the warnings

The greater the sensitivity of the warning settings, for example warning time, the more warnings will be displayed. As a result, there may be an increased number of incorrect warnings.

## Person warning with city braking function

### Principle

The system can help to avoid accidents with pedestrians.

The system warns of the possible risk of collision with pedestrians in the urban speed area and also contains a braking function.

The system is controlled by the camera in the area of the rear-view mirror.

### General

The system warns with sufficient brightness from approx. 10 km/h, approx. 6 mph up to approx. 60 km/h, approx. 35 mph of any risk of collision with pedestrians and supports this by briefly applying the brakes before a collision.

Here, persons are taken into account if they are located within the detection range of the system.

## Detection range

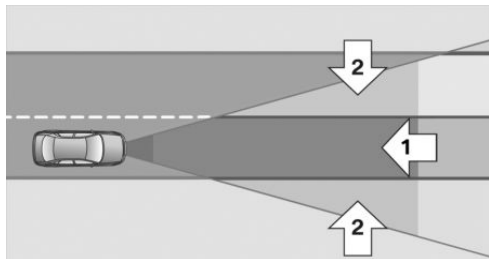

The detection zone in front of the vehicle consists of two parts:

- ▷ Central zone, arrow 1, directly in front of the vehicle.
- ▷ Extended zone, arrow 2, at right and left.

There is a risk of collision if persons are in the central zone. A warning is only given of persons in the extended zone if they are moving in the direction of the central zone.

## Notes



### WARNING

Displays and warnings do not take your personal responsibility from you. System limitations can mean that warnings or system responses are not issued, are issued too late, or are issued incorrectly. Danger of accidents. Adapt driving style to the driving conditions. Observe the traffic situation and intervene actively if the situation warrants it. ◀



### WARNING

Due to system limitations, there may be malfunctions of individual functions when tow-starting/towing with activated Intelligent Safety Systems, for example approach control warning with light braking function. Danger of accidents. Switch off all Intelligent Safety Systems before tow-starting/towing. ◀

## Overview

### Button in the vehicle



Intelligent Safety button

### Camera

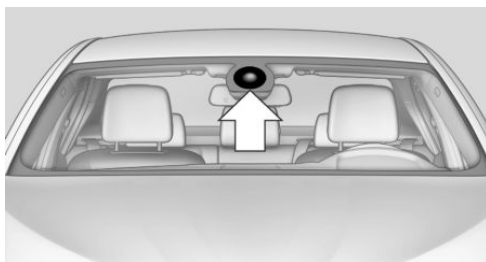

The camera is in the area of the base of the rear-view mirror.

Keep the windscreen clean and clear in the area in front of the rear view mirror.

## Switching on/off

### Automatic activation

The system is automatically activated at the start of each journey.

### Switching off



Press button: the systems are switched off again. LED turns off.

Press button again: the systems are switched on. LED is illuminated.

## Warning with braking function

### Display

If there is a risk of collision with a detected person, a warning symbol is shown in the instrument cluster and in the head-up display.



Red symbol is displayed and an acoustic warning sounds.

Take action yourself immediately, by braking or swerving.

### Brake intervention

The warning requires to take action yourself. Maximum braking force is used during a warning. In order for braking force support to be used, it is necessary for the brake to be pressed sufficiently quickly and powerfully. In addition, the system may also support with a small amount of braking if there is the risk of a collision. The vehicle can be braked at low speed until it comes to a stop.

Manual gearbox: When brakes are engaged until it comes to a stop, the engine may shut off.

There will only be brake intervention if Dynamic Stability Control, DSC is activated and M Dynamic Mode MDM is not activated.

Braking can be discontinued either by pressing the accelerator pedal or by actively moving the steering wheel.

Detection of objects can be restricted. Limitations of the detection range and functional restrictions are to be considered.

### System limits

#### Detection range

The detection capacity of the camera is limited.

This is why it can occur that no warnings are issued or they are issued late.

It is possible that the following are not detected:

- ▷ Partially concealed pedestrians.
- ▷ Pedestrians who are not detected as such because of the viewing angle or contour.
- ▷ Pedestrians outside the detection range.
- ▷ Pedestrians under a height of approximately 80 cm, 32 in.

### Restrictions of the function

The function may be restricted or not available in the following situations, for example:

The function may be available on a limited basis in the following situations, for example:

- ▷ In thick fog, rain, spray or snowfall.
- ▷ On sharp bends.
- ▷ When deactivating vehicle stability control systems, for example DSC OFF.
- ▷ If the field of view of the camera and/or the windscreen is dirty or covered.
- ▷ Up to 10 seconds after starting the engine using the start/stop button.
- ▷ During the calibration process of the camera immediately after the vehicle is supplied.
- ▷ When there is sustained glare effect due to light opposite, for example the sun low in the sky.
- ▷ In the dark.

## Lane departure warning

### Principle

This system warns if the vehicle leaves the lane, when the vehicle is on roads with lane markings and travelling above a given speed. Depending on country version, this speed is between 55 km/h, approximately 35 mph and 70 km/h, approximately 45 mph.

When switching on the system below this speed, a message is displayed in the instrument cluster.

When there are warnings, the steering wheel starts to vibrate slightly. The timing of this warning may vary depending on the current driving situation.

The system does not issue a warning if the driver indicates before leaving the driving lane.

## Information

### WARNING

The system does not take your personal responsibility from you when you are estimating the course of the road and traffic situation. Danger of accidents. Adapt driving style to the driving conditions. Observe the traffic situation and intervene actively if the situation warrants it. Do not move the steering wheel with unnecessary force in case of warnings. ◀

## Overview

### Button in the vehicle



### Lane departure warning

## Camera

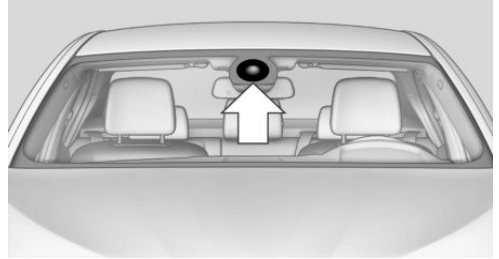

The camera is in the area of the base of the rear-view mirror.

Keep the windscreen clean and clear in the area in front of the rear view mirror.

## Switching on/off



Press the button.

- ▷ On: LED is illuminated.
- ▷ Off: LED turns off.

The setting is stored for the currently used profile.

## Display in the instrument cluster



- ▷ Lines: the system is activated.
- ▷ Arrows: at least one lane boundary line has been detected and warnings can be issued.

## Output of the warning

If the vehicle leaves the driving lane and a lane marking is detected, the steering wheel starts to vibrate.

If the turn indicator is set before changing lanes, no warning is issued.

## Cancellation of the warning

The warning is interrupted in the following situations:

- ▷ Automatically after approximately 3 seconds.

- ▷ On returning to the correct lane.
- ▷ With strong braking.
- ▷ On indicating.

### System limits

The function can be restricted, for example in the following situations:

- ▷ In thick fog and heavy rain or snow.
- ▷ With missing, worn, poorly visible, merging/separating or ambiguous boundary lines, for example in areas where there are road works.
- ▷ If boundary lines are covered by snow, ice, dirt or water.
- ▷ On sharp bends or narrow roads.
- ▷ If the boundary lines are not white.
- ▷ If boundary lines are obscured.
- ▷ If the vehicle is moving too close to the vehicle ahead.
- ▷ With bright oncoming light.
- ▷ When the windscreen in front of the rear-view mirror is covered with condensation, dirt, stickers, labels, etc.
- ▷ During the calibration process of the camera immediately after the vehicle is supplied.

## Lane change warning

### Principle

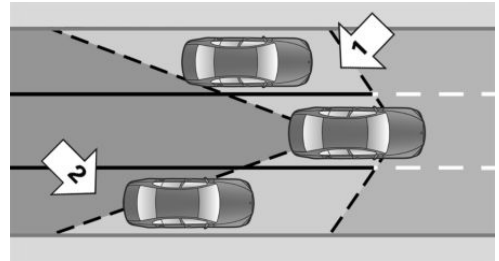

Two radar sensors in the rear bumper monitor the area behind and beside the vehicle as of approx. 20 km/h, approx. 12 mph.

In some equipment configurations, the radar sensors are active from approximately 50 km/h, approximately 30 mph.

The system indicates when vehicles are in the blind spot, arrow 1, or are approaching from the rear on an adjacent lane, arrow 2.

The light in the exterior mirror housing illuminates at a dimmed level.

Before changing lanes with the turn indicator switched on, the system issues a warning the above situations.

The light in the exterior mirror housing flashes and the steering wheel vibrates.

### Notes



#### WARNING

The system does not take your personal responsibility from you when you are estimating the visibility conditions and traffic situation. Danger of accidents. Adapt driving style to the driving conditions. Observe the traffic situation and intervene actively if the situation warrants it. ◀

## Overview

### Button in the vehicle



Lane change warning

### Radar sensors



The radar sensors are located in the rear bumper.

### Switching on/off



Press the button.

- ▷ On: LED is illuminated.
- ▷ Off: LED turns off.

The setting is stored for the currently used profile.

## Display

### Light in the exterior mirror housing

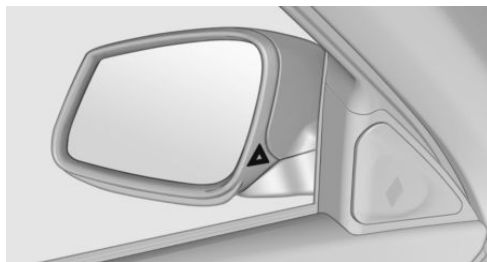

### Information level

The dimmed light in the exterior mirror housing indicates when vehicles are in the blind spot or are approaching from the rear.

### Warning

If the turn indicator is set while a vehicle is in the critical area, the steering wheel vibrates briefly and the light in the exterior mirror housing flashes brightly.

The warning is terminated when indicating is completed or the other vehicle has left the critical area.

### Brief flash

A brief flash of the light when unlocking the vehicle is used as a self-test of the system.

### System limits

The function can be restricted in the following situations:

- ▷ If the speed of the approaching vehicle is very much higher than that of your own speed.
- ▷ In thick fog and heavy rain or snow.
- ▷ On sharp bends or narrow roads.
- ▷ If the bumper is soiled, iced-over or a sticker is attached to it.

A Check Control message is displayed in the event of limited functionality.

## Manual speed limiter

### Principle

With the system, the speed can be restricted from a value of 30 km/h/20 mph. There are no restrictions below the set speed limit.

### Exceeding the speed limit

In particular situations the speed limit can be deliberately exceeded by accelerating strongly. The system gives a warning if the travelling speed exceeds the set speed limit.



### No brake intervention

If the set speed limit has been reached or unintentionally exceeded (for example driving downhill) there is no brake intervention.

If you set a speed limit during the journey which is below the current speed, the vehicle rolls until the driving speed drops below the speed limit.

## Overview

### Buttons on the steering wheel

Press the button	Function
	Switching system on/off, see page 119
	Rocker switch: Change speed limit, see page 119

## Controls

### Switching on

 Press the button on the steering wheel.

The current speed is assumed as the speed limit.

When switching on when at a standstill 30 km/h/20 mph is set as the speed limit.

The speedometer marker is set to the corresponding speed.

When activating the speed limit it is possible that Dynamic Stability Control, DSC is activated.

### Switching off

 Press the button on the steering wheel.

For example, the system is also deactivated in the following situations:

- ▷ When engaging reverse gear.
- ▷ When switching the engine off.
- ▷ When switching on Cruise Control.

The indicators turn off.

### Change speed limit

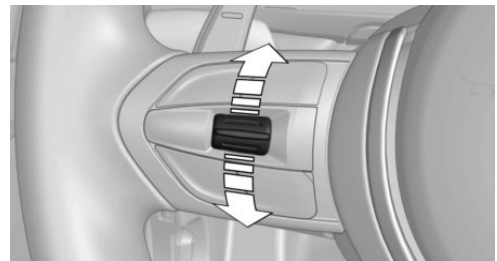

Press the rocker switch repeatedly upwards or downwards until the desired speed limit is set.

- ▷ Every time the rocker switch is pressed to the resistance point, the speed limit is increased or decreased by approximately 1 km/h, approximately 1 mph.
- ▷ Each time the rocker switch is pressed beyond the resistance point, the speed limit is increased or decreased to the next multiple of 10 km/h on the speedometer display.

If you set a speed limit during the journey which is below the current speed, the vehicle rolls until the driving speed drops below the speed limit.

## Exceeding the speed limit

You may intentionally exceed the speed limit. There is no acoustic warning in such a case.

To intentionally exceed the set speed limit, completely depress the accelerator pedal.

If the speed drops below the set speed limit, it is automatically reactivated.

## Warning

### Visual warning

**LIM** The indicator light in the instrument cluster flashes if the set speed limit is exceeded for as long as you exceed the set speed limit.

### Acoustic warning

- ▷ If you unintentionally exceed the set speed limit, you will hear an acoustic warning after approximately five seconds.
- ▷ If the speed limit is reduced to below the current speed during the journey, the warning sounds after approximately 30 seconds.
- ▷ If you intentionally exceed the speed limit by fully depressing the accelerator pedal, no warning is given.

## Displays in the instrument cluster

### Marking of the speed limit

Display in the speedometer:

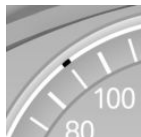

- ▷ Marker illuminates green: the system is active.
- ▷ Marker does not illuminate: the system is inactive.

### Indicator light

**LIM** ▷ If the indicator light is illuminated: the system is switched on.

- ▷ If the indicator light is flashing: set speed limit is exceeded.

### Brief status display

**LIMIT 90** Set speed limit briefly appears.

## Dynamic brake lights

### Principle



- ▷ Normal braking: brake lights illuminate.
- ▷ Severe braking: brake lights flash.

Shortly before the vehicle comes to a standstill, the hazard warning lights are activated.

Deactivating the hazard warning lights:

- ▷ Accelerating.
- ▷ Press the hazard warning lights button.

## Active Protection

### General

The Active Protection safety package consists of systems independent of each other:

- ▷ Attentiveness assistant.
- ▷ PreCrash.
- ▷ PostCrash.

## Attentiveness assistant

### Principle

The system can detect increasing inattentiveness or tiring of the driver on long monotonous drives, for example on motorways. In this situation, it is recommended that you take a break.

### Note



#### WARNING

The system does not take your personal responsibility from you when you are estimating your physical condition. Increasing inattention or fatigue might not be detected, or not in good time. Danger of accidents. Make sure that the drive is rested and alert. Adapt driving style to the driving conditions. ◀

### Function

The system is switched on every time the engine is started and cannot be switched off.

After the start of the drive, the system is adapted to the driver so that an increase in inattention or fatigue can be detected.

This process considers the following criteria:

- ▶ Personal driving style, for example, steering.
- ▶ Drive conditions, for example, time of day, duration of drive.

The system is active from approximately 70 km/h, 43 mph and can display a recommendation to take a break

### Recommendation to take a break

With increasing inattention or tiredness of the driver, an instruction is shown on the control display with the recommendation to take a break.

A recommendation to take a break will only be displayed once during an uninterrupted trip.

After a break, at the earliest another break recommendation may be displayed after approximately 45 minutes.

## System limits

The function may be restricted in situations such as the following and no warning or a wrong one is triggered:

- ▶ If the time is wrongly set.
- ▶ If the speed driven falls considerably below 70 km/h, 43 mph.
- ▶ For sporty driving style, for example, with heavy acceleration or fast cornering.
- ▶ In active drive situations, for example, frequent lane change.
- ▶ With bad road conditions.
- ▶ With high side-wind.

## PreCrash

### Principle

With the system from 30 km/h/20 mph critical driving situations may occur, which could cause an accident. In these situations, automatically preventative, protective measures are taken to minimise the risk of accident.

Critical driving situations are, for example:

- ▶ Full braking.
- ▶ Heavy understeering.
- ▶ Heavy oversteering.

When collision warning or front-end collision warning with braking function is fitted, within the limits of the system, threatened collisions into vehicles in front or stationary vehicles are detected.

### Note



#### WARNING

The system does not take your personal responsibility from you. Critical situations cannot be detected reliably or in good time due to limitations of the system. Danger of accidents. Adapt driving style to the driving conditions. Observe the traffic situation and intervene actively if the situation warrants it. ◀

## Function

After fastening the belt, the front belts are automatically pretensioned once when driving away.

When driving in critical situations, the following individual functions become active as required:

- ▷ The front belts are automatically pretensioned.
- ▷ The windows are automatically closed.
- ▷ The Glass Roof automatically closes.

After a critical driving situation without accident, the front belts are released again. All other systems can be put back into the desired setting.

If the belt tension does not loosen automatically, stop the vehicle and open the seat belt using the red button in the lock section. Fasten the seat belt again before continuing your journey.

## PostCrash

The system can automatically bring the vehicle to a standstill in certain accident situations without the involvement of the driver. The risk of a further collision and its consequences can thereby be reduced.

By depressing the brake pedal, the vehicle can be decelerated much faster. The automatic braking is interrupted as a result. By pressing the accelerator pedal, automatic braking is also interrupted.

After reaching a standstill, the brake is automatically triggered. Then secure the vehicle against rolling away.

# Driving stability control systems

## Vehicle equipment

This chapter describes all standard, national and special equipment provided in the model series. Equipment not available in the vehicle is therefore also described, for example the selected special equipment or national version. This also applies to safety-relevant functions and systems. Comply with the relevant national regulations when using the corresponding functions and systems.

## Anti-lock Brake System, ABS

ABS prevents the wheels from locking when the brakes are applied.

Steering control is retained even in the event of full braking, enhancing active road safety. ABS is ready to operate each time the engine is started.

## Brake assist

When brake is pressed quickly, this system automatically applies maximum braking power assistance. With full braking, this keeps the braking distance as short as possible. It also makes full use of the advantages offered by ABS.

Maintain pressure on the brake during the entire brake application.

## M Drive

### Principle

Individual settings can be made in two preset configurations for the vehicle.

When starting the engine, as standard an efficient vehicle state is active. M Drive is deactivated.







### Overview

### Configurations

The configurations are set as follows:

- ▷ "M Drive 1": relaxed, comfortable driving.
- ▷ "M Drive 2": sportive, dynamic driving.

### Setting options

Symbol	Meaning
	Dynamic Stability Control DSC, see page 124, and M Dynamic Mode MDM.
	Programs of the M Engine Dynamics Control, see page 78.
	Program of the Adaptive M chassis, see page 126.
	Programs of the Servotronic, see page 127.
	Drivelogic, see page 76: switching modes and Drivelogic drive programs.
	Views of the Head-Up Displays, see page 94.

### Configuring M Drive

The preset configurations can be individually set.

On the Control Display:

1. "Settings"
2. "M Drive 1" or "M Drive 2"

3. Selected desired adjustment option.
4. Select the desired channel.



The individual settings are stored for the currently used profile.

With M Drive activated a change is made immediately on the Control Display setting.

## Activating/deactivating M Drive

### Activating

Press the relevant button on the steering wheel.

- ▷  Activate M Drive 1
- ▷  Activate M Drive 2

If in M Drive, DSC OFF or MDM is set, a message appears in the instrument cluster. This message is operated by pressing the button again.

### Deactivating

Press the relevant button on the steering wheel again.

### Indicator Lights



- ▷ Indicator light illuminates: corresponding M Drive is activated.



- ▷ Indicator light flashes: M Drive could not be activated. Anti-blocking system ABS or Dynamic Stability Control DSC control drive stability directly.

Reactivate M Drive if the indicator stops flashing.

### Information

With activated M Drive individual settings outside of the M Drive can also be changed, for example, using buttons in the centre console. That deactivates the M Drive.

To reactivate all the settings made on the Control Display for M Drive, briefly press one of the following buttons:



To accept the change settings in M Drive, press the corresponding button for a long time.

### Reset M Drive

Individual settings can be reset to default values.

1. "Settings"
2. "M Drive 1" or "M Drive 2"
3. "Reset M Drive 1" or "Reset M Drive 2"
4. "Yes"

To interrupt resetting: "No"

## Dynamic Stability Control, DSC

### Principle

DSC prevents the driven wheels losing traction when you pull away from rest or accelerate.

DSC is also able to detect unstable driving conditions such as loss of traction at the rear or vehicle slip over the front wheels. DSC reduces engine output and applies the brakes at individual wheels, helping, within the limits imposed by the laws of physics, to keep the vehicle safely on course.

### Note

Adapt the driving style to the situation as it is always the driver's responsibility to adapt a suitable driving style.

Not even DSC can overcome the laws of physics.

Do not limit the additional safety afforded by this system by taking driving risks.

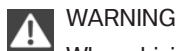
**WARNING**

When driving with a roof load, for example with a roof rack, the higher centre of gravity can mean that driving safety is no longer guaranteed in critical driving situations. Danger of accident or damage to property. Do not deactivate Dynamic Stability Control DSC when driving with a roof load. ◀

**Overview****Button in the vehicle**

DSC OFF button

**Indicator and warning lights**

If indicator light is flashing: DSC is regulating the acceleration and braking forces.

If indicator light is illuminated: DSC has failed.

**Deactivating DSC: DSC OFF****General**

Driving stability during acceleration and cornering is restricted if DSC is deactivated.

To support the driving stability, re-activate DSC as soon as possible.

**Deactivating DSC**

Press and hold down the button – but for no longer than approximately 10 seconds – until the DSC OFF indicator light in the in-

strument cluster is illuminated and DSC OFF is displayed.

The DSC system is switched off.

**Activating DSC**

Press the button.

The DSC OFF and DSC OFF indicator lights are not illuminated.

**Indicator and warning lights**

DSC OFF is displayed in the instrument cluster when DSC is deactivated.



If indicator light is illuminated: DSC is deactivated.

**M Dynamic Mode**

M Dynamic Mode allows driving with higher longitudinal and transverse acceleration on dry carriageways, but with restricted drive stability.

Only in the absolute limit of the range does the system engage for stability purposes by reducing the engine power and by brakes applied to the wheels. In this driving situation, additional steering corrections may be required.

**WARNING**

With activated M Dynamic Mode stabilising engagements are only carried out to a reduced degree. Danger of accident or damage to property. Adapt to the traffic conditions. Observe the traffic situation and intervene actively if the situation warrants it. Do not move the steering wheel with unnecessary force in case of warnings. ◀

To support the driving stability, re-activate DSC as soon as possible.

**Activating MDM**

Press the button briefly.

In the instrument cluster, the indicator lights MDM and DSC OFF illuminate.

## Deactivating MDM



Press the button.

Indicator lights MDM and DSC OFF no longer illuminate.

### Via M Drive

On the Control Display:

1. "Settings"
2. "M Drive 1" or "M Drive 2"
3.  Select the symbol.
4. "MDM"

To call up the desired M Drive with the selected settings, press the corresponding button on the steering wheel:



A message appears in the instrument cluster. This message is operated by pressing the button again.

## Deactivating MDM

Press the corresponding button 1 or button 2 on the steering wheel again.

M Dynamic Mode and the settings selected under M Drive are deactivated.

### Indicator and warning lights



Indicator lights illuminate:  
M Dynamic Mode is activated.



DSC indicator light also flashes:  
M Dynamic Mode is regulating the driving and braking forces.



Indicator lights illuminate:  
M Dynamic Mode or DSC has failed.

## Active M Differential

### Principle

The active M Differential blocks the rear axis transmission steplessly, depending on the drive situation. In so doing, even with the DSC switched off and in M Dynamic Mode, spinning of a single rear wheel is avoided and therefore optimum traction is provided under all driving conditions.

The driver is responsible for a driving style appropriate to the situation.

## Adaptive M chassis

### Principle

The system reduces unwanted vehicle movements when a dynamic driving style is used or on uneven roads.

Depending on the condition of the road and the driving style, this enhances driving dynamics and driving comfort.

### Programs

Possibilities for adjusting the tuning of the shock absorbers:

- ▷ "Comfort": comfort-oriented
- ▷ "Sport": balanced
- ▷ "Sport Plus": consistently sporty

### Selecting program

#### Via M Drive

1. "Settings"
2. "M Drive 1" or "M Drive 2"
3.  Select the symbol.
4. Select the desired channel.

Setting is immediately accepted with active M Drive.

To activate the desired M Drive with the selected settings, press the corresponding button on the steering wheel:



## Using the button



 Press button until the desired program is displayed in the instrument cluster.

## Display in the instrument cluster

 Adaptive M chassis with selected program and activated display of driving dynamics system statuses, see page 86.

## Drive-off assistant

The system provides support when driving off on upward inclines. It is not necessary to use the parking brake for this.

1. Hold the vehicle in place by pressing the foot brake.
2. Release the foot brake and drive off without delay.

The vehicle is held for approximately 2 seconds after the foot brake has been released.

Depending on the vehicle's load or when towing a trailer, the vehicle may roll backwards a little.

## Servotronic

### Principle

The Servotronic varies the steering force required when steering, depending on the speed. At low speeds the steering force is heavily supported, in other words a slight force is needed when steering. With increasing speed the support for the steering force is reduced.

In addition, steering force is adapted according to drive program, giving a sporty/direct or comfortable steering response.

### Programs

Adjustment possibilities of the steering force:

- ▷ "Comfort": low.
- ▷ "Sport": medium.
- ▷ "Sport Plus": high.

## Selecting program

### Via M Drive

On the Control Display:

1. "Settings"
2. "M Drive 1" or "M Drive 2"
3.  Select the symbol.
4. Select the desired channel.

Setting is immediately accepted with active M Drive.

To activate the desired M Drive with the selected settings, press the corresponding button on the steering wheel:



## Using the button



 Press button until the desired program is displayed in the instrument cluster.

## Display in the instrument cluster

 Servotronic with selected program with activated display of the system states of the driving dynamics, see page [86](#).

# Driving comfort

## Vehicle equipment

This chapter describes all standard, national and special equipment provided in the model series. Equipment not available in the vehicle is therefore also described, for example the selected special equipment or national version. This also applies to safety-relevant functions and systems. Comply with the relevant national regulations when using the corresponding functions and systems.

## Cruise Control

### Principle

System keeps to speed set using buttons on steering wheel. On downhill gradients, the system will brake the vehicle if the braking action of the engine alone is insufficient.

### General

Characteristics of Cruise Control may change in certain areas depending on vehicle setting.

### Information

#### WARNING



Using the system in the following situations can lead to an increased danger of accident:

- ▷ On stretches with many corners and bends.
- ▷ In heavy traffic.
- ▷ If the road is icy, if there is fog, snow, rain or a loose road surface.

Danger of accident or damage to property. Only use the system if it is possible to drive at a constant speed. ◀

## Overview

### Buttons on the steering wheel

Press the button	Function
	Cruise Control on, off, interrupt, see page 129.
	Resume speed, see page 130.
	Rocker switch: change, hold or set speed, see page 130.

## Controls

### Switching on

 Press the button on the steering wheel.

The speedometer marker is set to the current speed.

Cruise Control can be used.

If necessary, Dynamic Stability Control DSC will be switched on.

### Switching off

#### WARNING

The system does not take your personal responsibility from you when you are estimating the traffic situation. Due to limits of the system, it cannot respond independently in a reasonable way in all traffic conditions. Danger of accidents. Adapt driving style to the driving conditions. Observe the traffic situation and intervene actively if the situation warrants it. ◀

 Press the button on the steering wheel.

- ▷ When activated: press twice.

- ▶ When interrupted: press once.

The indicators turn off. The saved desired speed is deleted.

## Interrupting



When the system is activated, press the button on the steering wheel.

The system interrupts automatically in the following situations:

- ▶ If the brake is applied.
- ▶ If the clutch is depressed for a few seconds or released with no gear engaged.
- ▶ If too high a gear has been engaged for the speed.
- ▶ If MDM is activated or DSC is deactivated.
- ▶ If DSC intervenes.

## Maintaining, saving, changing speed

### Notes



#### WARNING

The desired speed can be inadvertently set incorrectly or called up. Danger of accidents. Adapt the desired speed to the driving conditions. Observe the traffic situation and intervene actively if the situation warrants it. ◀

## Maintaining speed, saving

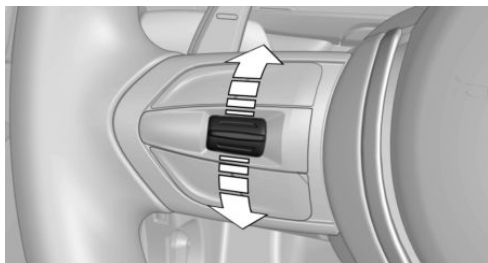

During the interruption, press the rocker switch.

With the system switched on, the driven speed is maintained and saved as the desired speed.

This is shown in the speedometer and briefly in the instrument cluster, see page 130.

If necessary, Dynamic Stability Control DSC will be switched on.

## Changing speed

Press the rocker switch repeatedly upwards or downwards until the desired speed is set.

With the system active, the speed that is then shown is set and will be achieved on a clear road.

- ▶ Each time the rocker switch is pressed lightly up to the resistance point, the desired speed is increased or decreased by approximately 1 km/h, 1 mph.
- ▶ Each time the rocker switch is pressed beyond the resistance point, the desired speed is increased or decreased to the next multiple of 10 km/h on the speedometer display.

The maximum speed which can be set depends on the vehicle.

- ▶ Pressing the rocker switch until the resistance point is reached and holding accelerates or decelerates the vehicle without pressing the accelerator pedal.

The speed is maintained after letting go of the rocker switch. Pressing beyond the resistance point results in greater vehicle acceleration.

## Call up desired speed



Press the button on the steering wheel.

The saved speed is regained and maintained.

## Displays in the instrument cluster

### Indicator light



Depending on the equipment the indicator light in the instrument cluster

shows whether the system is switched on.

### Desired speed



- ▷ Marker illuminates green: the system is active.
- ▷ Marker illuminates orange: the system is interrupted.
- ▷ Marker does not illuminate: the system is inactive.

### Brief status display



Selected desired speed.

If no speed is displayed, the conditions required for operation may not be fulfilled at the moment.

### Displays on the Head-Up Display

Some information from the system can also be shown on Head-Up Display.

## Park Distance Control PDC

### Principle

PDC supports you with parking. Slowly approaching an object in behind, or with front PDC, in front of, your vehicle is signalled by means of:

- ▷ Acoustic signals.
- ▷ Visual display.

### General

Ultrasonic sensors in each bumper measure the distance.

The range is approximately 2 m, 6 ft depending on obstacle and environment.

An acoustic warning is only issued under the following circumstances:

- ▷ At the front sensors and at the two corner sensors at the rear at approx. 60 cm, 24 in.

- ▷ At the central sensors at the rear at approx. 1.5 m, 5 ft.
- ▷ If there is a collision risk.

### Notes



#### WARNING

The system does not take your personal responsibility from you when you are estimating the traffic situation. Due to limits of the system, it cannot respond independently in a reasonable way in all traffic conditions. Danger of accidents. Adapt driving style to the driving conditions. Observe the traffic situation and intervene actively if the situation warrants it. ◀



#### WARNING

If the vehicle is travelling at high speed when PDC is activated, there may be a delayed warning because of physical conditions. Danger of injury or damage to property. Avoid approaching an object at speed. Avoid moving off at speed while PDC is not yet active. ◀

### Overview

#### With front PDC: button in vehicle



Park Distance Control PDC

### Ultrasonic sensors



PDC sensors on the vehicle.

## Functional requirements

To ensure correct functionality:

- ▶ Do not cover sensors, for example by stickers, bicycle rack.
- ▶ Keep sensors clean and free from ice.

For cleaning: do not spray the sensors with high-pressure cleaners for an extended period of time and maintain a distance of at least 30 cm, 12 in.

## Switching on/off

### Automatic switching on

While the engine is running, engage selector lever position R.

### Automatic switching off when moving forwards

The system switches off when a certain distance or speed is exceeded.

Switch the system back on if necessary.

### With front PDC: switching on/off manually



Press the button.

- ▶ On: LED is illuminated.
- ▶ Off: LED turns off.

## Display

### Audible warning signals

An intermittent sound indicates position of an object as the vehicle approaches it. For instance, if an object is identified to the rear left of the vehicle, the warning signal sounds from the rear left loudspeaker.

The shorter the distance to an object becomes, the shorter the intervals become.

If the distance to a detected object is less than approximately 25 cm, 10 in, a continuous tone sounds.

With front PDC: if there are objects in front of and behind the vehicle, an alternating continuous tone sounds.

## Volume control

It is possible to set the ratio between the volume of the PDC acoustic signal and the volume of the Entertainment.

1. "Multimedia", "Radio" or "Settings"
2. "Sound"
3. "Volume settings"
4. "PDC"
5. Turn the Controller until the desired setting is reached.
6. Press the Controller.

The setting is saved for the currently used profile.

## Visual warning

When the vehicle is approaching an object it will be shown on the Control Display. Objects that are further away from the vehicle will appear on the Control Display before an acoustic signal is given.

A display is superimposed as soon as PDC is activated.

Recording range of sensors is shown in colours green, yellow and red.

If the reversing camera image is displayed, it is possible to change over to PDC:

 "Rear view camera"

## System limits

### Limits of the ultrasound measurement

Detection of objects might not be possible if the limits of the physical ultrasound measurement are exceeded, such as for instance at the following times:

- ▶ With small children and animals.

- ▷ With persons with certain clothing, for example a coat.
- ▷ With external disruption to the ultrasound, for example by passing vehicles or loud machines.
- ▷ If the sensors are dirty, iced-up, damaged or incorrectly adjusted.
- ▷ In certain weather conditions, for example high humidity, rain, snowfall, extreme heat or strong wind.
- ▷ With trailer noses and tow hitches of other vehicles.
- ▷ With thin or wedge-shaped objects.
- ▷ With moving objects.
- ▷ For higher, protruding objects, for example projecting walls or loads.
- ▷ For objects with corners and sharp edges.
- ▷ For objects with fine surfaces or structures, for example fences.
- ▷ For objects with porous surfaces.

Low objects already indicated, such as kerbs, may enter the sensors' blind areas before or after a continuous tone is given.

### False alarms

Under the following conditions, PDC can issue a warning although there is no obstacle in the detection range:

- ▷ In heavy rain.
- ▷ If the sensors are very dirty or covered with ice.
- ▷ If the sensors are covered with snow.
- ▷ On rough road surfaces.
- ▷ On uneven ground, for example speed bumps.
- ▷ In large, rectangular buildings with smooth walls, for example underground car parks.
- ▷ In car washes.
- ▷ Due to dense exhaust gas.

- ▷ Due to other ultrasonic sources, for example sweeping machines, steam-jet cleaners or neon lights.

The functional disruption is reported by an alternating continuous tone between the front and rear loudspeakers. As soon as the disruption by other ultrasound sources is no longer present, the system is fully functional again.

### Malfunction

A Check Control message is shown.

The recording area of the sensors is shown hatched on the Control Display.

PDC has failed. Have the system checked.

## Surround view

### Principle

Surround view contains various camera assistance systems, providing support when parking, manoeuvring and exits and junctions with poor visibility.

- ▷ Rear-view camera, see page 133.
- ▷ Side view, see page 136.
- ▷ Top view, see page 137.

## Rear-view camera

### Principle

The rear-view camera offers assistance when reversing into a parking space or manoeuvring. To achieve this, the area behind the vehicle is displayed on the Control Display.

### Notes



#### WARNING

The system does not take your personal responsibility from you when you are estimating the traffic situation. Danger of accidents. Adapt driving style to the driving conditions.

Additionally, look directly to check the traffic situation and the area around the vehicle and intervene actively in the corresponding situations. ◀

## Overview

### Button in the vehicle



Rear-view camera

## Camera

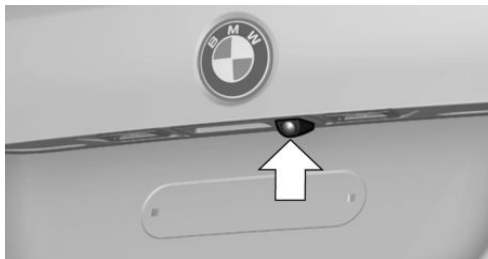

The camera lens is located in the handle strip of the boot lid. Dirt can impair the quality of the picture.

Clean the lens of the camera, see page 211.

## Switching on/off

### Automatic activation

While the engine is running, engage selector lever position R.

The image from the rear-view camera is displayed if the system was switched on using the iDrive.

### Automatic switching off when moving forwards

The system switches off when a certain distance or speed is exceeded.

Switch the system back on if necessary.

### Switching on/off manually



Press the button.

- ▷ On: LED is illuminated.
- ▷ Off: LED turns off.

PDC is displayed on the Control Display.

### Switching the view via iDrive

With activated PDC or Top View switched on:

 "Rear view camera"

The image from the rear-view camera is displayed.



### Display on the Control Display

#### Operating requirements

- ▷ The rear-view camera is switched on.
- ▷ The boot lid is completely closed.

#### Activating assistance functions

A number of assistance functions can be active simultaneously.

- ▷ Parking aid lines.
  -  "Parking guidance lines"
 Driving lane and turning circle lines are displayed.
- ▷ Obstacle marking.
  -  "Obstacle marking"
 Spatially shaped markings are displayed.

## Driving lane lines

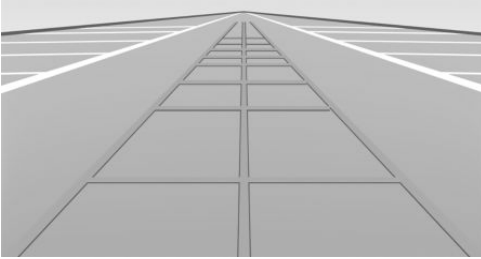

Driving lane lines can appear in the image from the rear-view camera.

The driving lane lines help to estimate the required space when parking and manoeuvring on a level road surface.

The driving lane lines are dependent on the current steering angle and are continuously adapted to steering wheel movements.

## Turning circle lines

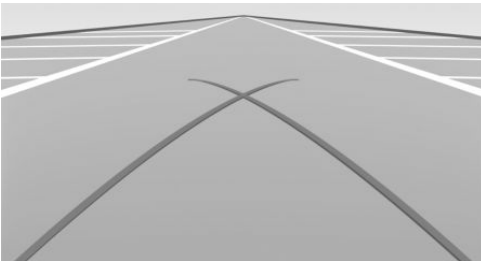

The turning circle lines can only be shown in the image from the rear-view camera together with driving lane lines.

The turning circle lines show the course of the smallest possible turning circle on a level road surface.

When the steering wheel is turned to a certain extent, only a turning circle line is shown.

## Obstacle marking

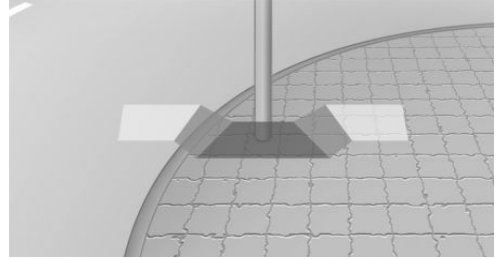

Obstacle markings can be shown in the image from the rear-view camera.

The colour incrementation corresponds to the markings of PDC.

## Parking with the help of driving lane and turning circle lines

1. Position the vehicle so that the turning circle lines are within the limit of the parking space.

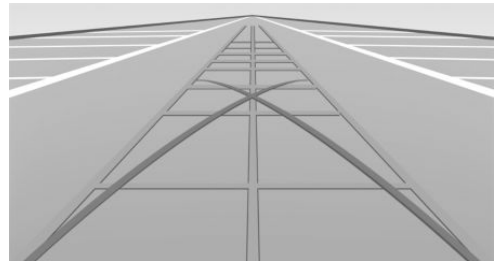

2. Turn the steering wheel so that the driving lane line covers the corresponding turning circle line.

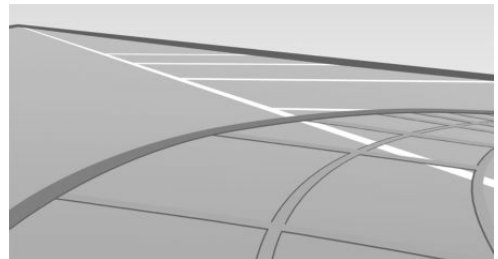

## Display settings

### Brightness

With rear-view camera switched on:

1. ☀ Select the symbol.
2. Turn the controller until the desired setting is reached and press the controller.

### Contrast

With rear-view camera switched on:

1. 🎛 Select the symbol.
2. Turn the controller until the desired setting is reached and press the controller.

## System limits

### Detection of objects

Very low obstacles and higher, protruding objects such as ledges cannot be detected by the system.

Assistance functions also consider data from the PDC.

Follow notes in the PDC chapter, see page 131.

The objects shown on the Control Display may be closer than they appear. Do not estimate the distance to objects on the display.

## Side View

### Principle

Side View provides you with an advance view of crossing traffic at blind entrances. Road users hidden by obstacles at the side are only detected very late from the driver's seat. In order to improve the view, two cameras in the front area of the vehicle scan the area to the side.

## Notes

The camera pictures are shown simultaneously on the Control Display.



### WARNING

The system does not take your personal responsibility from you when you are estimating the traffic situation. Danger of accidents. Adapt driving style to the driving conditions. Additionally, look directly to check the traffic situation and the area around the vehicle and intervene actively in the corresponding situations. ◀

## Overview

### Button in the vehicle



Side View

## Cameras

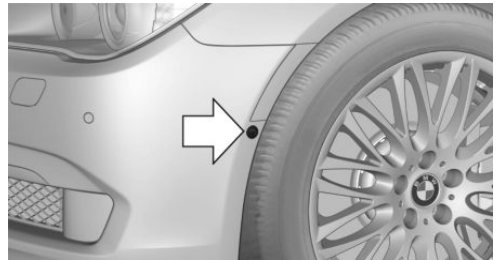

Two cameras integrated into the bumpers provide detection.

Both camera lenses are located at the side of the bumper.

Dirt can impair the quality of the picture.

Cleaning camera lenses, see page 211.

## Switching on/off

### Switching on/off manually



Press the button.

### Automatic switching off when moving forwards

The system switches off when a certain distance or speed is exceeded.

Switch the system back on if necessary.

### Display

The area to the side is shown on the control display.

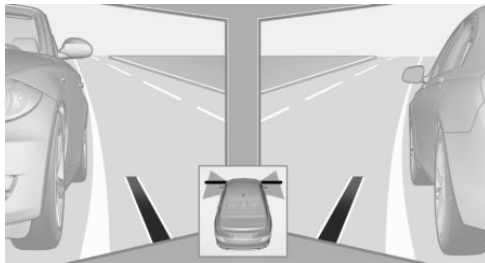

Artificial lines on the lower screen edge show the position of the vehicle front.

### Brightness

With Side View switched on:

1. ☀ "Brightness"
2. Turn the controller until the desired setting is reached and press the controller.

### Contrast

With Side View switched on:

1. ● "Contrast"
2. Turn the controller until the desired setting is reached and press the controller.

## System limits

The pick-up range of the cameras is a maximum of 100 m, 330 ft.

## Top View

### Principle

Top View assists you with manoeuvring and parking. To achieve this, the area around the door and road is displayed on the control display.

### General

The two cameras in the exterior mirrors and the rear-view camera are used to view the area around the car.

The range at the sides and rear is at least 2 m, approx. 7 ft.

In this way, obstacles up to the height of the exterior mirror are detected early.

### Notes



#### WARNING

The system does not take your personal responsibility from you when you are estimating the traffic situation. Danger of accidents. Adapt driving style to the driving conditions. Additionally, look directly to check the traffic situation and the area around the vehicle and intervene actively in the corresponding situations. ◀

## Overview

### Button in the vehicle



 Top View

### Cameras

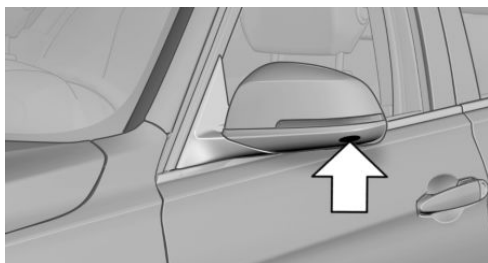

The lenses of the Top View cameras are located in the base of the mirror housings. Dirt can impair the quality of the picture.

Cleaning camera lenses, see page [211](#).

### Switching on/off

#### Automatic activation

While the engine is running, engage selector lever position R.

The images from Top View and PDC are displayed if the system was switched on using the iDrive.

#### Automatic switching off when moving forwards

The system switches off when a certain distance or speed is exceeded.

Switch the system back on if necessary.

### Switching on/off manually



Press the button.

- ▷ On: LED is illuminated.
- ▷ Off: LED turns off.

Top View is shown.

### Display

#### Visual warning

When the vehicle is approaching an object it will be shown on the Control Display.

If there is a short distance to an object at the front, a red bar in front of the vehicle is displayed in the same way as for the PDC display.

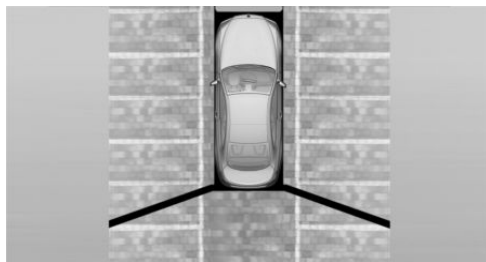

The display appears as soon as Top View is activated.

If the reversing camera image is displayed, it is possible to change over to Top View:

 "Rear view camera"

#### Brightness

With Top View switched on:

1.  Select the symbol.
2. Turn the controller until the desired setting is reached and press the controller.

#### Contrast

With Top View switched on:

1.  Select the symbol.

2. Turn the controller until the desired setting is reached and press the controller.

### Displaying the turning circle and driving lane line

- ▷ The static red turning circle line indicates the space requirement to the side with full steering angle.
- ▷ The variable green driving lane line helps to estimate the actual space requirement to the side.

The lane line depends on the engaged gear and the current steering angle. The lane line is continuously adjusted by the steering wheel movement.

#### "Parking guidance lines"

The turning circle and driving lane lines are displayed.

### System limits

Top View cannot be used in the following situations:

- ▷ With a door open.
- ▷ With the boot lid open.
- ▷ With an exterior mirror folded in.
- ▷ In poor light conditions.

In some of these situations a Check Control message is displayed.

## Park Assistant

### Principle

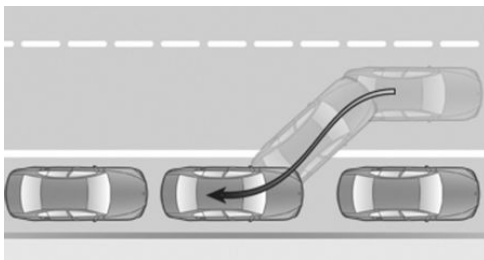

The system supports you when parking in parallel to the road.

Ultrasonic sensors measure parking spaces on both sides of the vehicle.

The park assistant calculates the ideal parking line and takes over steering during the process of parking.

When parking up, also follow the visual and audible information and notes of the PDC, the Park Assistant and the rear-view camera, and respond accordingly.

The park assistant incorporates Park Distance Control, PDC, see page 131.

### Notes

#### WARNING

The system does not take your personal responsibility from you when you are estimating the traffic situation. Due to limits of the system, it cannot respond independently in a reasonable way in all traffic conditions. Danger of accidents. Adapt driving style to the driving conditions. Observe the traffic situation and intervene actively if the situation warrants it. ◀

#### ATTENTION

The Park Assistant may steer across curbs or up onto curbs. Danger of damage to property. Observe the traffic situation and intervene actively if the situation warrants it. ◀

An engine stopped by the Auto Start Stop function is automatically started by activating the Park Assistant.

## Overview

### Button in the vehicle

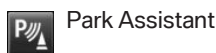

Park Assistant

### Ultrasonic sensors

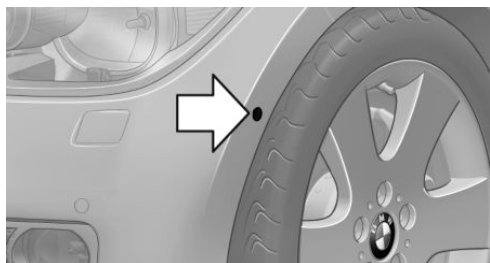

To ensure correct functionality:

- ▷ Keep sensors clean and free from ice.
- ▷ Do not spray the sensors with high-pressure cleaners for an extended period of time and maintain a distance of at least 30 cm, 12 in.
- ▷ Do not stick things onto the sensors.

## Requirements

### To measure parking spaces

- ▷ When the vehicle is moving forwards straight up to approximately 35 km/h, approximately 22 mph.
- ▷ Maximum distance to the row of parking vehicles: 1.5 m, approximately 5 ft.

### Suitable parking space

- ▷ Gap between two objects, each of which are at least 1.5 m, approximately 5 ft long.
- ▷ Minimum length of gap between two objects: own vehicle length plus approximately 1.2 m, approximately 4 ft.
- ▷ Minimum depth: approximately 1.5 m, approximately 5 ft.

### For the process of parking

- ▷ Doors and boot lid closed.
- ▷ Parking brake released.
- ▷ You must indicate accordingly when parking into parking spaces on the driver's side.

## Switching on/off

### Switching on with the button



Press the button.

LED is illuminated.

The current status of the parking space search is displayed on the Control Display.

 Park Assistant is automatically activated.

### Switching on with reverse gear

Engage reverse gear.

The current status of the parking space search is displayed on the Control Display.

To activate:  "Park Assist"



### Switching off

The system can be deactivated by:

- ▷  Press the button.
- ▷ Switch the ignition off.

## Display on the Control Display

### System is activated/deactivated

Symbol	Meaning
	Grey: system not available. White: system available but not activated.
	System is activated.

### Status of the system

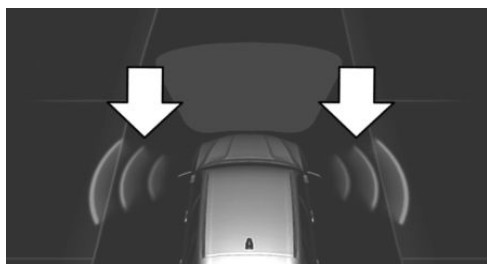

- ▷ Coloured symbols, see arrows, on the side of the vehicle display. Park Assistant is activated and parking space search is active.
- ▷ Suitable parking spaces are shown on the Control Display on the edge of the roadway next to the vehicle symbol. With active Park Assistant, the suitable parking spaces are highlighted in colour.
- ▷  Parking process active. Steering has been taken over.
- ▷ The parking space search is always active with slow straight forward driving, even with deactivated system. With deactivated system, the displays on the Control Display are shown grey.

### Status of the system

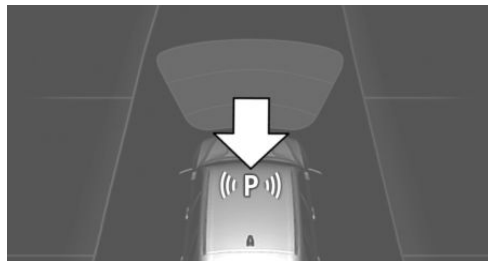

- ▷ Symbol P, see arrow, on the vehicle display. Park Assistant is activated and parking space search is active.
- ▷ Suitable parking spaces are shown on the Control Display on the edge of the roadway next to the vehicle symbol. With active Park Assistant, the suitable parking spaces are highlighted in colour.
- ▷ When perpendicular or parallel parking spaces are definitely detected, the system automatically sets the appropriate parking method. A selection menu is displayed for parking spaces that are large enough for both parallel and perpendicular parking. In this case, select the desired parking method manually.
- ▷  Parking process active. Steering has been taken over.
- ▷ The parking space search is always active with slow straight forward driving, even with deactivated system. With deactivated system, the displays on the Control Display are shown grey.

### Parking with the Park Assistant



#### WARNING

The system does not take your personal responsibility from you when you are estimating the traffic situation. Danger of accidents. Adapt driving style to the driving conditions. Additionally, look directly to check the traffic

situation and the area around the vehicle and intervene actively in the corresponding situations. ◀

1. Switch on the Park Assistant and activate, if applicable.

Status of the parking space search is displayed on the Control Display.

2. Follow the instructions on the Control Display.

To achieve an optimum parking position, wait for the automatic steering process after changing gear at standstill.

The end of the parking process is displayed on the Control Display.

3. Straighten up the parking position, if applicable.

### Cancelling manually

You can cancel the Park Assistant at any time:

- ▷  "Park Assist" Select the symbol on the Control Display.

- ▷  Press the button.

### Cancelling automatically

The system automatically cancels in the following situations:

- ▷ When holding firmly onto the steering wheel or even if steering is done.
- ▷ When selecting gear, which does not correspond to the information on the Control Display.
- ▷ At speeds over approx. 10 km/h, approx. 6 mph.
- ▷ Possibly on snow-covered or slippery road surfaces.
- ▷ Any obstacles difficult to get over, for example kerbstones.
- ▷ With obstacles that suddenly arise.
- ▷ If the Park Distance Control PDC shows gaps are too small.

- ▷ When a maximum number of parking attempts or parking time is exceeded.
- ▷ If turn indicator is set opposite to desired parking side.
- ▷ When changing to other functions on the Control Display.

A Check Control message is shown.

### Flashing display on selector lever of double clutch transmission

In some situations, the actually engaged gearbox setting may be different from the selector lever position after a cancellation of function, and the display in the selector lever flashes.

In these cases, refer to the display in the instrument cluster, see page 75.

### Continuing

You can continue a cancelled parking process, if applicable.

For this purpose, follow the instructions on the Control Display.

### System limits

#### No parking support

The Park Assistant does not support in the following situations:

- ▷ On sharp bends.

#### Restrictions of the function

The function can be restricted, for example in the following situations:

- ▷ When on uneven road surfaces, for example gravel roads.
- ▷ On slippery ground.
- ▷ On steep upward or downward gradients.
- ▷ If leaves have collected or snow has drifted or been piled up in the parking space.

## Limits of the ultrasound measurement

Detection of objects might not be possible if the limits of the physical ultrasound measurement are exceeded, such as for instance at the following times:

- ▷ With small children and animals.
- ▷ With persons with certain clothing, for example a coat.
- ▷ With external disruption to the ultrasound, for example by passing vehicles or loud machines.
- ▷ If the sensors are dirty, iced-up, damaged or incorrectly adjusted.
- ▷ In certain weather conditions, for example high humidity, rain, snowfall, extreme heat or strong wind.
- ▷ With trailer noses and tow hitches of other vehicles.
- ▷ With thin or wedge-shaped objects.
- ▷ With moving objects.
- ▷ For higher, protruding objects, for example projecting walls or loads.
- ▷ For objects with corners and sharp edges.
- ▷ For objects with fine surfaces or structures, for example fences.
- ▷ For objects with porous surfaces.

Low objects already indicated, such as kerbs, may enter the sensors' blind areas before or after a continuous tone is given.

In some cases, parking spaces may be detected that are not suitable or suitable parking spaces may not be detected.

## Malfunction

A Check Control message is shown.

The Park Assistant has failed. Have the system checked.

# Climate

## Vehicle equipment

This chapter describes all standard, national and special equipment provided in the model series. Equipment not available in the vehicle is therefore also described, for example the se-

lected special equipment or national version. This also applies to safety-relevant functions and systems. Comply with the relevant national regulations when using the corresponding functions and systems.

## Automatic air conditioning

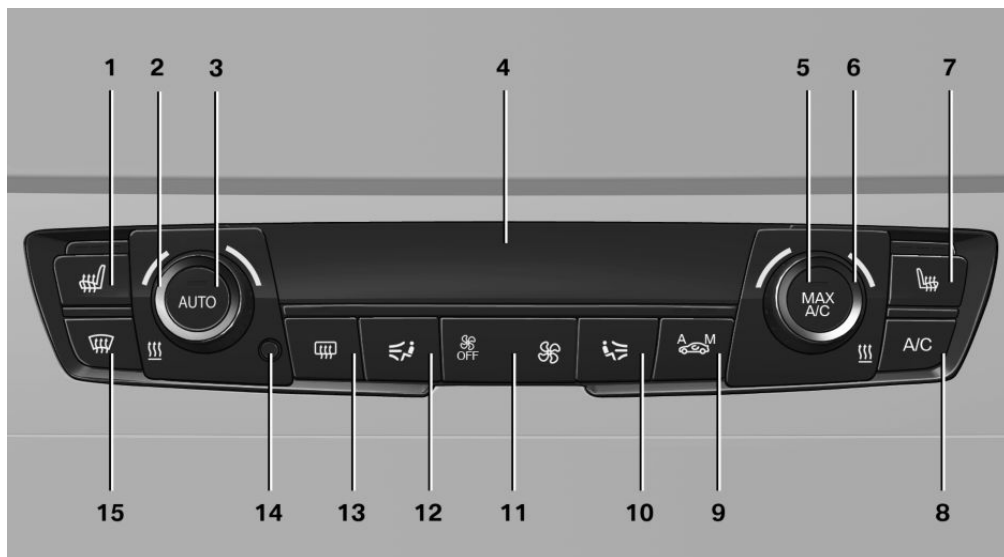

- |   |                        |    |    |  |
|---|------------------------|----|----|--|
| 1 | Seat heating, left     | 50 | 9  | AUC/recirculated-air mode                    |
| 2 | Temperature, left      |    | 10 | Air distribution, right                      |
| 3 | AUTO program           |    | 11 | Air flow, AUTO intensity                     |
| 4 | Display                |    | 12 | Air distribution, left                       |
| 5 | Maximum cooling effect |    | 13 | Heated rear window                           |
| 6 | Temperature, right     |    | 14 | Interior temperature sensor — never cover    |
| 7 | Seat heating, right    | 50 | 15 | Defrosting windows and removing condensation |
| 8 | Cooling function       |    |    |  |

## Air conditioning functions in detail

### Switching system on/off

#### Switching on

Press any key, except

- ▷ Heated rear window.
- ▷ Seat heating

#### Switching off



In the lowest setting, press the left of the button.

### Temperature



Turn the wheel to select the desired temperature.

The automatic air conditioning sets this temperature as quickly as possible, using higher cooling or heating power if necessary. The temperature is then maintained.

Avoid switching between different temperature settings in rapid succession. The automatic air conditioning will not then have sufficient time to establish the temperature selected.

### Cooling function

The interior can only be cooled when the engine is running.



Press the button.

Air is cooled and dried, then reheated to suit the temperature setting.

Depending on weather conditions, the windscreen and side windows may mist over momentarily when the engine is started.

The cooling function is switched on automatically in the AUTO program.

When using the automatic air conditioning, condensation water, see page 165, develops that exits underneath the vehicle.

### Maximum cooling effect



Press the button.

System is set to lowest temperature, optimum air flow and recirculated-air mode.

The air flows from the outlets for the upper body area. Therefore open the ventilation vents.

The function is available through an outside temperature of approximately 0 °C/32 °F and with the engine running.

The air flow can be adapted when the program is active.

### AUTO program



Press the button.

The air flow, air distribution and temperature are automatically regulated.

Depending on the selected temperature, intensity AUTO program and external influences, the air is directed towards the windscreen, side windows, upper body, and into the footwell.

The cooling function, see page 145, is switched on automatically in the AUTO program.

A condensation sensor also controls the program so that condensation is avoided as much as possible.

### Intensity of AUTO program

When AUTO program is switched on, automatic control of the intensity can be changed.



Pressing the button on the left or right reduces or increases intensity.

The selected intensity is shown on the display for automatic air conditioning.

## Automatic air recirculation control, AUC/recirculated-air mode

If the air outside the vehicle has an unpleasant odour or contains pollutants, the supply to the interior of the vehicle can be shut off. The air inside the vehicle is then recirculated.



Press button repeatedly to call up an operating mode:

- ▷ LEDs off: ambient air is constantly entering the car.
- ▷ Left-hand LED on, AUC mode: a sensor detects pollutants in the outside air and shuts it out automatically.
- ▷ Right-hand LED on, recirculated-air mode: the ambient air supply is permanently shut off.

The recirculated-air mode automatically switches off at low outside temperatures after a given time, to avoid condensation.

Continuous recirculated-air mode deteriorates the air quality in the interior and condensation on the windows increases.

If there is condensation on the window, switch off recirculated-air mode and press the AUTO button to use the condensation sensor. Ensure that air can flow towards the windscreen.

## Adjusting the air flow manually

To be able to adjust the air flow manually, first switch off the AUTO program.



Pressing the button on the left or right reduces or increases the air flow.

The selected air flow is shown on the display for automatic air conditioning.

In order to protect the battery the air flow rate of the automatic air conditioning is reduced, if necessary.

## Adjusting the air distribution manually



Press button repeatedly to select a program:

- ▷ Upper body area.
- ▷ Upper body area and footwell.
- ▷ Footwell.
- ▷ Windows and footwell: only on the driver's side.
- ▷ Windows, upper body area and footwell: only on the driver's side.

If there is condensation on the window, press the AUTO button in order to use the condensation sensor.

## Defrosting windows and removing condensation



Press the button.

This removes ice and condensation quickly from the windscreen and the front side windows.

To do this, point the side nozzles at the side windows if necessary.

The air flow can be adapted when the program is active.

If there is condensation on the window, switch on the cooling function as well or press the AUTO button to use the condensation sensor.

## Heated rear window



Press the button.

The heated rear window is switched off automatically after a certain period of time.

## Microfilter/activated charcoal filter

In outside and recirculated-air mode, the microfilter/activated carbon filter filters dust, pollen and harmful gases from the air.

This filter should be changed during maintenance on your vehicle, see page 191.

## Ventilation

### Ventilation at front

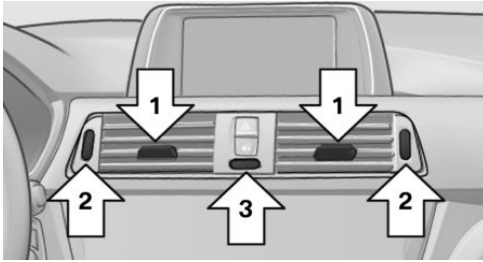

- ▶ Lever to change the direction in which air flows, arrows 1.
  - ▶ Knurled wheels to open and close the air outlets continuously, arrow 2.
  - ▶ Knurled wheel for varying temperature in upper body area, arrow 3.  
Towards blue: cooler  
Towards red: warmer.
- Set interior temperature for driver and front seat passenger is not changed.

### Setting the ventilation

- ▶ Ventilation for cooling:  
Adjust the side nozzles so that air is directed towards you, for example if the vehicle's interior has become hot.
- ▶ Draught-free ventilation:  
Adjust the side nozzles so that the air flows past you.

### Ventilation in rear passenger compartment

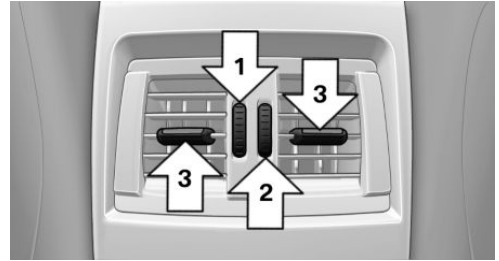

- ▶ Knurled wheel to open and close the air outlets continuously, arrow 1.
- ▶ Knurled wheel for varying the temperature, arrow 2.  
Towards blue: cooler  
Towards red: warmer.
- ▶ Lever to change the direction in which air flows, arrow 3.

## Independent ventilation

### Principle

The independent ventilation system ventilates the passenger compartment and lowers its temperature under some circumstances.

The system can be switched on and off at any ambient temperature either directly or via two preselected switch-on times. It remains switched on for 30 minutes.

Open the ventilation vents so the air can flow out.

### Switching on/off directly

On the Control Display:

1. "Settings"
2. "Climate"
3. "Activate aux. ventilation"

☞ symbol on automatic air conditioning flashes when system is switched on.

## Preselecting the switch-on time

On the Control Display:

1. "Settings"
2. "Climate"
3. "Start time 1:" or "Start time 2:"
4. Set desired time.

## Activating the switch-on time

On the Control Display:

1. "Settings"
2. "Climate"
3. "Activate start time 1" or "Activate start time 2"

 Symbol on the automatic air conditioning system is illuminated when the switch-on time is active.

 Symbol on the automatic air conditioning system flashes when the system has cut in.

The system switches on within the next 24 hours only. Afterwards, it must be reactivated.

# Interior equipment

## Vehicle equipment

This chapter describes all standard, national and special equipment provided in the model series. Equipment not available in the vehicle is therefore also described, for example the selected special equipment or national version. This also applies to safety-relevant functions and systems. Comply with the relevant national regulations when using the corresponding functions and systems.

## Sun visor

### Glare protection

Fold the sun visor downwards or upwards.

### Vanity mirror

A vanity mirror is situated in the sun visor behind a cover. The mirror light switches on when the cover is opened.

## Ashtray/lighter

### Ashtray

#### Opening

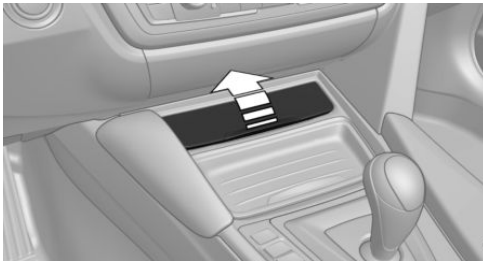

Remove lid.

### Emptying

Lift out the insert.

### Lighter



#### WARNING

Touching the hot heating element or the hot fitting of the cigarette lighter can cause burns. Flammable materials can catch fire if the lighter falls down or is held against corresponding objects. Danger of fire and injury. Grip the cigarette lighter by the handle. Make sure that children cannot use the lighter and burn themselves, for example by taking the remote control with you when leaving the vehicle. ◀



#### ATTENTION

If metallic objects fall into the socket, they can cause a short circuit. Danger of damage to property. After using the socket, put the lighter or socket cover back on. ◀



The cigarette lighter is located next to the ashtray.



Press in the cigarette lighter.

The cigarette lighter can be removed when it pops back out.

## Connecting electrical appliances

### Information

#### ATTENTION

Battery chargers for the vehicle battery can operate with high voltages and high currents, which can overload or damage the 12 volt on-board network. Danger of damage to property. Only connect battery chargers for the vehicle battery to the jump-starting connections in the engine compartment. ◀

#### ATTENTION

If metallic objects fall into the socket, they can cause a short circuit. Danger of damage to property. After using the socket, put the lighter or socket cover back on. ◀

### Power sockets

#### General

Cigarette lighter socket can be used as a socket for electrical devices when the engine is running or the ignition is switched on.

#### Note

The total load of all sockets must not exceed 140 Watt at 12 Volt.

To avoid damage to the socket, do not insert an incompatible plug.

#### Front centre console



Lift the lid and remove the cover or lighter.

#### Rear centre console



Remove the cover.

#### Inside the boot

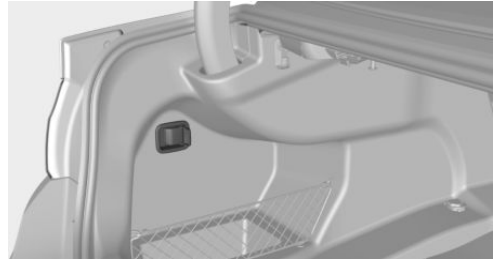

Socket is on the left in the boot.

## USB interface for data transfer

### Principle

Connection for importing and exporting data on a USB medium, for example:

- ▷ Personal Profile settings, see page 33.
- ▷ Music collection.
- ▷ Importing trips.

### Notes

When connecting, bear the following in mind:

- ▷ Do not insert the plug forcibly in the USB interface.
- ▷ Do not connect any devices such as fans or lights to the USB interface.

- ▷ Do not connect up USB hard drives.
- ▷ Do not use the USB audio interface for charging external devices.

### Without telephone: overview

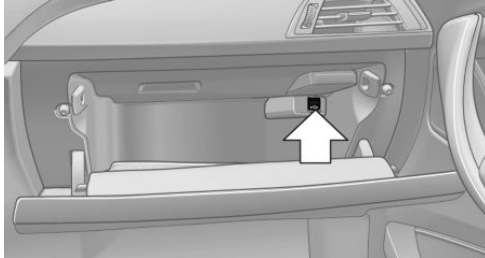

The USB interface is in the glove box

### With telephone: overview

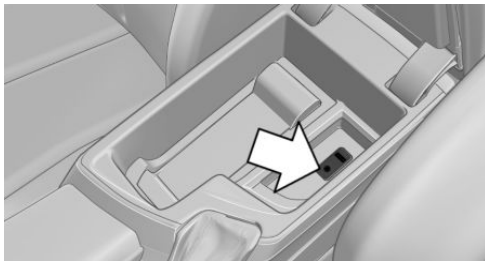

The USB interface is in the centre armrest.

## Through-loading system

### Principle

The boot can be enlarged by folding down the rear seat backrest.

The rear seat backrest is split 60–40.

Each side can be folded down individually or you may fold down the entire rear seat backrest.

### Notes



#### WARNING

Risk of trapping when folding down the backrest. Danger of injury or damage to property. Before folding down, make sure that the movement area of the rear backrest is clear. ◀



#### WARNING

If the seat adjustment or child seat installation is incorrect, the stability of the child restraint system will be restricted or rendered ineffective. Danger of injury or life. Make sure the child restraint system is firmly positioned against the backrest. In all relevant backrests, adapt the backrest angle if possible and set the seats correctly. Make sure that the seats and their backrests are correctly engaged. If possible, adjust the height of the head restraints, or remove them. ◀

### Opening

1. Pull the corresponding lever in the boot to unlock the rear seat backrest.

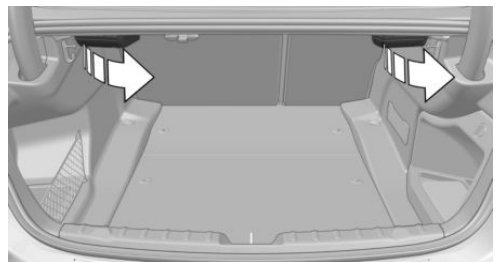

2. The unlocked backrest moves slightly to the front.



3. Fold the backrest forwards.

## Closing



### WARNING

Unsecured cargo can be thrown into the interior due to an unlocked backrest, e.g. in the event of an accident, braking or avoidance manoeuvres. Danger of injury. Make sure that the locking mechanism engages when folding back the backrest. ◀

Fold the rear backrest back into seat position and engage.

For securing the load, see page [166](#), with nets or tensioning bands there are lashing eyes in the boot.

# Storage compartments

## Vehicle equipment

This chapter describes all standard, national and special equipment provided in the model series. Equipment not available in the vehicle is therefore also described, for example the selected special equipment or national version. This also applies to safety-relevant functions and systems. Comply with the relevant national regulations when using the corresponding functions and systems.

## Notes



### WARNING

Loose objects in the interior can be thrown into the interior during the journey, for example in an accident or during braking and evasive manoeuvres. Danger of injury. Secure loose objects in the interior. ◀



### ATTENTION

Anti-slip mats can damage the dashboard. Danger of damage to property. Do not use anti-slip mats. ◀

## Storage options

The following storage options are located in the interior:

- ▶ Glove box on the passenger side, see page 153.
- ▶ Glove box on the driver's side, see page 154.
- ▶ Without smoker's package: front compartment, in front of cupholders, see page 154.
- ▶ Storage compartment in the front centre armrest, see page 154.
- ▶ Pockets in the doors, see page 154.

- ▶ Nets on the backrests of the front seats.
- ▶ Storage compartment between the rear seats, see page 155.

## Glove box

### Front passenger's side

#### Note



### WARNING

The glove box projects into the interior when it is opened. Objects in the glove box can be thrown into the interior during the journey, for example in an accident or during braking and evasive manoeuvres. Danger of injury. Immediately close the glove box after using it. ◀

### Opening

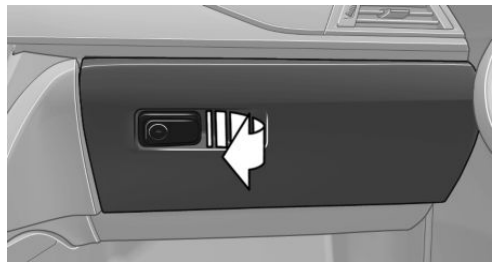

Pull the handle.

The lighting in the glove box comes on.

The net in the glove box is stowing the inlay for the cupholder, see page 155.

### Closing

Fold lid down.

## Locking

The glove box can be locked with an integrated key. This means it is not possible to access the glove box.

After the glove box has been locked, the remote control without the integrated key can be handed over, for example, at a hotel.

## Driver's side

### Note

 **WARNING**

The glove box projects into the interior when it is opened. Objects in the glove box can be thrown into the interior during the journey, for example in an accident or during braking and evasive manoeuvres. Danger of injury. Immediately close the glove box after using it. ◀

## Opening



Pull the handle.

## Closing

Fold lid down.

## Front compartment

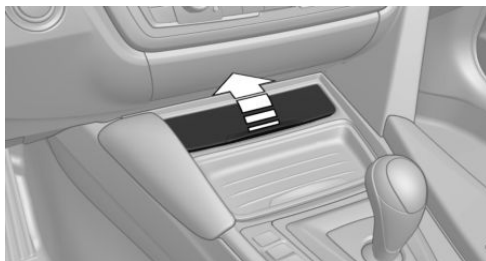

Lift lid to open.

## Pockets in the doors

 **WARNING**

Fragile objects, for example glass bottles, can break in the event of an accident. Shards can spread throughout the interior. Danger of injury. Do not store any fragile objects in the interior. ◀

## Centre armrest

### Front

There is a storage compartment in the centre armrest between the front seats.

### Opening

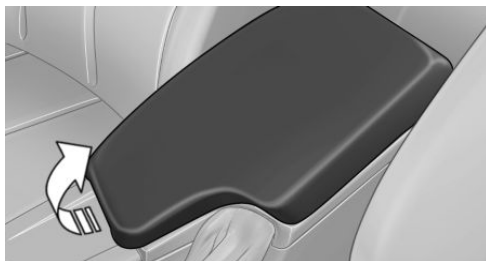

Fold the centre armrest upwards.

## Sliding

Centre armrest can be slid in the longitudinal direction. It engages into the end positions.

## Connection for external audio device



An external audio device, for example an MP3 player, can be connected through the AUX-IN port or the USB audio interface in the centre armrest.

## Storage compartment between the rear seats

A storage compartment is located between the rear seats.

## Cupholder

### Note



#### WARNING

Unsuitable containers in the cupholder and hot drinks can damage the cupholders, and increase the risk of injury in an accident. Danger of injury or damage to property. Use light, lockable containers that are shatterproof. Do not transport hot drinks. Do not force objects into the cupholder. ◀

### Front



## Fittings for front cupholders

With the fitting, the cupholders can be used as an extra compartment. To do this, put the fittings into the cupholder.

Only use fittings for small object, for example a key or remote control.

When not in use, stow the fittings in the net in the glove box. To do this, plug the fittings with the top upwards in the net. Observe the trapezoidal shape of net and fitting.

## Coat hooks



#### WARNING

Items of clothing on the coat hooks can impair visibility when driving. Danger of accidents. Hang items of clothing from the hooks so they do not obstruct visibility when driving. ◀



#### WARNING

Incorrect use of the coat hooks can represent a danger, for example if objects fly around in the case of braking and evasive manoeuvres. Danger of injury and damage to property. Only hang light objects, for example items of clothing, on the coat hooks. ◀

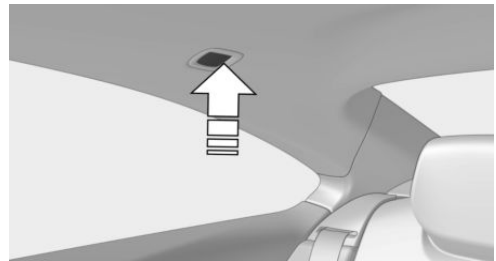

To open, press top edge.

## Storage compartments in the boot

### Storage compartment

There is a storage compartment on the left.

On the right-hand side there is a storage compartment for on-board toolkit, see page 193, and first-aid kit, see page 203.

### Net

Smaller objects can be stowed in the net on the left-hand side.

### Bag holders



#### WARNING

Incorrect use of the holders can represent a danger, for example if objects fly around in the case of braking and evasive manoeuvres. Danger of injury and damage to property. Only hang light objects, for example shopping bags, on the holders. Only transport heavy luggage with suitable means of securing in the boot. ◀

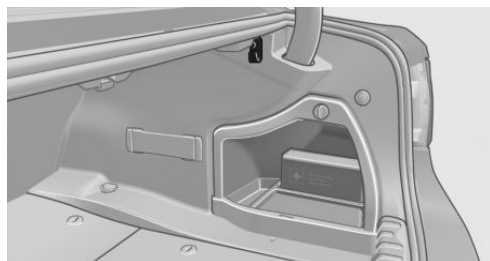

In the boot there is a bag holder on every side.

### Tensioning strap

There is a tensioning strap on the right-hand trim panel for securing small objects.

### Lashing eyes in the boot

For securing the load, see page 166, four lashing eyes are in the boot.

### Floor net

For securing the load, see page 166, and for keeping small parts, the floor net can also be used.

### Storage compartment under the boot floor

For the storage compartment under the boot floor, do not exceed a maximum permitted load of 20 kg, approx. 44 lb.

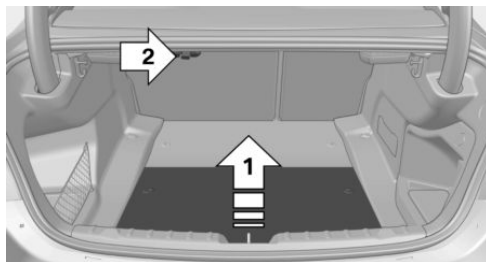

Lift the boot floor, arrow 1, and engage upwards, arrow 2, as needed.

### Divide compartment

The compartment can be divided with a plug-gable divider.





## **Driving hints**

The Driving hints chapter provides you with information that you may require in particular driving situations or operating modes.

# BMW M4 Technology

## Vehicle equipment

This chapter describes all standard, national and special equipment provided in the model series. Equipment not available in the vehicle is therefore also described, for example the selected special equipment or national version. This also applies to safety-relevant functions and systems. Comply with the relevant national regulations when using the corresponding functions and systems.

## High performance engine

The high performance engine generates a maximum power of 317 kW and a maximum torque of 550 Nm from 3 litres of capacity. With its spontaneous responsiveness, a very broad usable engine speed range is produced. The maximum engine speed is electronically regulated at 7,600 rpm. Due to the powerful engine dynamics, the maximum engine speed is limited when the vehicle is stationary.

### Driving hot

During the engine warm-up phase, the high performance engine runs slightly more roughly due to the emission control.

When the engine is cold, the exhaust has a slightly metallic undertone, depending on the system.

Other information for hot driving: engine speed counter, see page [84](#), and engine oil temperature, see page [84](#).

## M compound brakes

The high performance brake system has ventilated compound brake discs.

Depending on design requirements, function noises may occur when braking. However, this

has no effect on the performance, operational safety and stability of the brakes.

### Braking correctly

To keep the brake system in optimum condition, it is desirable to load them at regular intervals depending on the nature of the vehicle.

## M Carbon ceramic brakes

The high performance braking system has perforated carbon ceramic brake disks and is designed for racetrack operation.

Depending on the material-specific properties, there can be increased functional noises when braking, particularly when it is wet, shortly before the vehicle comes to a stop. This has no effect on performance, operational safety and endurance of the brakes.

Due to the effect of wet and salt spray, for example, after using a car wash, condensation overnight etc., the braking effect may correspond to a conventional braking system. This can be detected as reduced braking effect and compensated for by higher pedal pressure, as needed.

Clean brake discs and brake calliper before washing in an automatic car wash with a steam sprayer or high pressure cleaner to avoid encrustations and caking, for example, due to salt crystals with a related stationary period. The cleaning effect of automatic car washes generally not sufficient for this in the wheel area.

Also follow the information on this under vehicle washing, see page [208](#), and safe braking, see page [163](#).

## Drivetrain

In this vehicle, particular attention is paid to the direct connection from the engine to the drivetrain. Due to the torsionally stiff design of the drivetrain, as usual in a sports car, the transmission of the torque is can also be heard.

When there are load changes, it can therefore cause clattering noises. They do not affect the functioning or durability of the components.

## Driving on a racing track

### Requirements

For driving on a racing track:

- ▶ Participation in a training course from BMW Driving Experience.
- ▶ Check engine oil level and top up with engine oil as required.
- ▶ Have vehicle checked by a Service Partner or a qualified specialist workshop.

### Notes

Racing track operation causes increased wear. The vehicle is not designed for use in motor-sport competitions. This wear is not covered by the warranty.

The standard brake pads and the wear displays are not designed for racing track operation. Further information and advice are available from a Service Partner or a qualified specialist workshop.

# Driving precautions

## Vehicle equipment

This chapter describes all standard, national and special equipment provided in the model series. Equipment not available in the vehicle is therefore also described, for example the selected special equipment or national version. This also applies to safety-relevant functions and systems. Comply with the relevant national regulations when using the corresponding functions and systems.

## Running in

### General

Moving parts need a certain time to achieve maximum operating efficiency as a unit.

The following information helps to achieve maximum service life and efficiency of the vehicle.

Do not use Launch Control, see page 77, when running in.

### Engine, gearbox and differential

#### Up to 2000 km, 1200 miles

Drive with alternating revolutions and speeds, but do not exceed 5500 rpm and 170 km/h, approximately 106 mph.

In principle, avoid full load or kick-down.

#### At 2000 km, 1200 miles

Have maintenance conduct a drive-in service.

#### From 2000 km, approximately 1200 miles to 5000 km, approximately 3100 miles

Revolutions and vehicle speed can gradually be increased to a continuous speed of 220 km/h, approximately 137 mph.

The maximum speed of 250 km/h, approximately 155 mph is only to be used briefly, for example when overtaking.

### Tyres

New tyres do not achieve their full road grip immediately, for production reasons.

During the first 300 km, 200 miles, drive moderately.

### Brake system

Brake pads and discs of the M compound brakes only achieve a favourable wear and contact pattern after approximately 500 km, approximately 300 miles. Drive moderately during this running-in period.

Brake discs and pads of the M carbon ceramic brakes only achieve a favourable wear and contact pattern after approx. 1000 km, approx. 600 miles. Drive moderately during this running-in period.

### Clutch

The clutch only begins to function optimally at approximately 500 km, approximately 300 miles. Engage the clutch gently during this running-in period.

### After fitting new parts

The same running-in procedures should be observed if any of the components mentioned above have to be renewed in the course of the vehicle's operating life.

## General driving information

### Closing the boot lid



#### WARNING

An open boot lid projects beyond the vehicle, and in the event of an accident, braking or avoidance manoeuvres, it can endanger vehicle occupants and other road users, or damage the vehicle. There is also the danger of exhaust fumes entering the interior of the vehicle. Danger of injury or damage to property. Do not drive with the boot lid open. ◀

If there is no alternative to driving with the tailgate open:

- ▷ Close all windows and the Glass Roof.
- ▷ Turn up the blower to a high output level.
- ▷ Maintain moderate speed.

### Hot exhaust system



#### WARNING

During driving, high temperatures can be generated under the body, for example because of the exhaust system. If flammable materials, for example leaves of grass, come into contact with hot parts of the exhaust system, these materials can catch fire. Danger of injury or damage to property.

Never remove the heat shields fitted here, or apply underseal to them. Make sure that when driving, idling or parking, no flammable materials can come into contact with hot vehicle parts. Do not touch the hot exhaust system. ◀

### Radio signals



#### WARNING

Certain vehicle functions may be affected by interference from high-frequency radio signals. Such signals are output from a series of transmission systems, for example, from air traffic beacons or relay stations for mobile telecommunications.

We recommend you consult a Service Partner or a qualified specialist workshop should you experience any difficulties. ◀

### Mobile communication equipment



#### WARNING

The vehicle's electronics and mobile radio devices can interfere. The transmission operation of mobile radio devices generates radiation. Danger of injury or damage to property. If possible, only use mobile radio devices, e.g. mobile telephones, in the interior with direct connection to an external antenna to exclude mutual interference and to dissipate the radiation from the vehicle's interior. ◀

### Aquaplaning

On wet or slushy roads, a wedge of water can form between the tyres and the road.

This situation, known as aquaplaning, means that the tyre can actually lose contact completely with the road surface and the vehicle can neither be steered nor the brakes properly applied.

### Wading



#### ATTENTION

Driving through excessively deep water too fast can result in water entering the engine compartment, electrical system or transmission. Danger of damage to property. When driving through water, do not exceed the maximum specified water depth and maximum fording speed. ◀

Only if the water is calm and only up to a water depth of max. 25 cm, approximately 9.8 inches and at this depth drive no faster than walking speed up to 5 km/h, approximately 3 mph.

### Safe braking

Your vehicle is equipped with ABS as standard.

Applying the brakes fully is the most effective way of braking in situations in which this is necessary.

The vehicle can be steered. Any obstacles can be avoided with steering wheel movements that are as calm as possible.

A pulsing of the brake pedal shows that ABS is regulating.

In certain braking situations, the perforated brake disks can cause functional noise. However, this has no effect on the efficiency and operational safety of the brakes.

### Objects in the range of movement of the pedals and in the footwell



#### WARNING

Objects in the driver's footwell can restrict the pedal travel, or block a pedal that has been pressed. Danger of accidents. Stow items in the vehicle so that they are secure and cannot get into the driver's footwell. Only use floor mats that have been categorised as appropriate for the vehicle and that can be fastened accordingly. Do not use any loose floor mats, and do not place several floor mats on top of one another. Make sure that there is sufficient space for the pedals. Ensure that the floor mats are securely reattached after having been removed, for example for cleaning. ◀

### Wet roads

In damp weather, if road grit has been spread or there is heavy rain, apply the brakes lightly every few kilometres/miles.

In doing so, do not obstruct other road users.

The resulting heat dries the brake discs and pads.

The braking force will be available immediately if needed.

### Downhill gradients



#### WARNING

Even slight, continuous pressure on the brake pedal can cause overheating, brake pad wear or even brake system failure. Danger of accidents. Avoid excessive loads on the brake. ◀



#### WARNING

When idling or with the engine switched off, safety-relevant functions are restricted or no longer available, for example the braking effect of the engine or power assistance for the braking force and steering. Danger of accidents. Do not drive at idle speed or with the engine switched off. ◀

When driving on long or steep downhill stretches, use the gear in which the least braking is required. Otherwise the brake system can overheat and braking action is reduced.

Manual gearbox:

The braking effect can be additionally increased by shifting down, even into first gear, if applicable.

M double clutch transmission:

The braking action of the engine can be boosted further by shifting down in sequential mode, see page 75.

### Corrosion of the brake disc

Corrosion of the brake discs and contamination of the brake pads increase with the following circumstances:

- ▷ Low mileage.
- ▷ Extended periods when the vehicle is not used.
- ▷ Infrequent use of the brakes.

Corrosion occurs when the minimum pressure that must be exerted by the pads during brake applications to clean the discs is not reached.

Should corrosion form on the brake discs, the brakes will tend to respond with a pulsating effect that generally cannot be corrected.

### Condensate when vehicle is parked

When using the automatic air conditioning, condensation water develops that exits underneath the vehicle.

Traces of water on the ground are normal.

### Ground clearance



#### ATTENTION

If there is insufficient ground clearance, the front or rear spoiler can touch the ground, for example at curb edges or when driving into underground car parks. Danger of damage to property. Make sure that there is sufficient ground clearance. ◀

When driving down from kerb edges, select the following program with the adaptive M suspension, see page 126, to keep the ground clearance as uniform as possible: "Sport Plus"

### M Driver's Package: driving in maximum speed range



#### WARNING

At high speeds, damage to vehicle parts can unfavourably influence driving properties. These include tyres, underbody and parts for improving aerodynamics. Danger of accidents. Have damage rectified by a Service Partner or a qualified specialist workshop. Do not drive at high speed until the damage has been repaired. ◀

# Loads

## Vehicle equipment

This chapter describes all standard, national and special equipment provided in the model series. Equipment not available in the vehicle is therefore also described, for example the selected special equipment or national version. This also applies to safety-relevant functions and systems. Comply with the relevant national regulations when using the corresponding functions and systems.

## Notes

### WARNING

A high gross vehicle weight can cause the tyres to overheat, causing internal damage and a sudden loss of tyre pressure. Danger of accidents. Comply with the permitted load index of the tyre, and do not exceed the permitted gross vehicle weight. ◀

### WARNING

If the permitted total weight and the permitted axle loads are exceeded, operational safety of the vehicle is not ensured anymore. Danger of accidents. Do not exceed the permitted total weight and permitted axle loads. ◀

### ATTENTION

Liquids in the boot can cause damage. Danger of damage to property. Make sure that no liquids leak out in the boot. ◀

### WARNING

Loose objects in the interior can be thrown into the interior during the journey, for example in an accident or during braking and evasive manoeuvres. Danger of injury. Secure loose objects in the interior. ◀

## Stowing transported loads

- ▶ Wrap protective material around sharp corners and edges of the load.
- ▶ Heavy transported load: stow as far forward and as low down as possible, ideally directly behind the rear backrests.
- ▶ Very heavy transported load: with no passengers on the back seat, insert both outer seat belts into the respective opposite buckles.
- ▶ Fully fold down the rear-seat backrest if the load is to be stowed accordingly.
- ▶ Do not stack storage goods above the upper edge of the backrests.

## Securing transported loads

### Lashing eyes in the boot

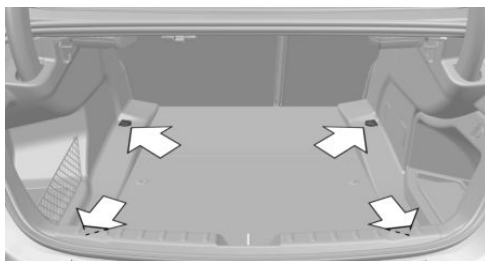

For securing the load four lashing eyes are in the boot.

### Floor net

For securing the load and for keeping small parts, the floor net can also be used.

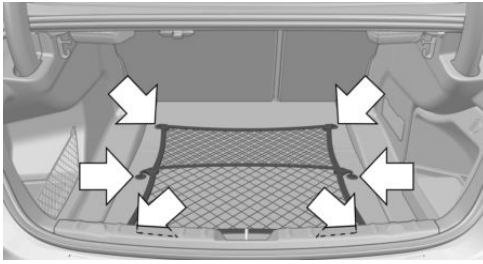

Hang the floor net on the eyes in the boot floor.

## Securing transported loads



### WARNING

Incorrectly stowed objects can slip or be thrown into the interior, for example in an accident, during braking or evasive manoeuvres. Vehicle occupants could be hit and injured. Danger of injury. Stow and secure the objects and the load correctly. ◀

- ▷ Smaller and lighter parts: with tensioning straps, to secure the floor net or other suitable straps.
- ▷ Relatively large and heavy objects: secure with lashing straps.

Fasten tensioning straps of various kinds to the lashing eyes in the boot.

## Roof rack

### Note

Roof racks are available as special equipment.

### Fastening

Follow fitting instruction of the roof rack.

## Roof strip with flaps

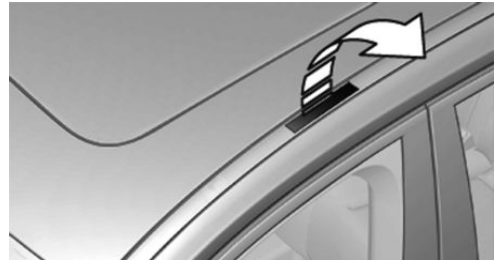

The mounting points are located on the roof strip above the doors.

Fold the cover outwards.

## Loads

A loaded roof rack alters the vehicle's road behaviour and steering response by shifting its centre of gravity.

When loading and driving, bear the following in mind:

- ▷ Do not exceed permitted roof and axle load as well as the permitted gross weight.
- ▷ Make sure that there is sufficient space to raise and open the Glass Roof.
- ▷ Distribute the roof load evenly.
- ▷ The roof load must not be spread over a large area.
- ▷ Place heavy items of luggage at the bottom.
- ▷ Securely fasten roof rack, for example with tensioning straps.
- ▷ Do not allow objects to protrude into the swing range of the boot lid.
- ▷ Drive cautiously and avoid sudden acceleration, braking or cornering.

# Saving fuel

## Vehicle equipment

This chapter describes all standard, national and special equipment provided in the model series. Equipment not available in the vehicle is therefore also described, for example the selected special equipment or national version. This also applies to safety-relevant functions and systems. Comply with the relevant national regulations when using the corresponding functions and systems.

## General

Your vehicle contains wide-ranging technologies for reducing consumption and emission levels.

Fuel consumption depends on various factors.

A number of measures, such as a moderate driving style and regular maintenance, can influence fuel consumption and reduce burden on environment.

## Removing transported load that is not required

Extra weight increases fuel consumption.

## Removing add-on parts after use

Remove auxiliary mirrors, roof racks and rear-mounted racks after use.

Add-on parts on the vehicle interfere with its aerodynamic performance and inflate fuel consumption.

## Closing windows and the glass roof

An opened glass roof or opened window increases the drag coefficient and thus reduces the range.

## Tyres

### General

Tyres can have differing effects on fuel consumption. For example, fuel consumption can be affected by tyre size.

### Checking tyre pressures regularly

Check and, if necessary, correct tyre inflation pressures at least twice a month and before setting off on a longer journey.

Insufficient tyre inflation pressure enlarges the rolling resistance and thus increases fuel consumption and tyre wear.

## Setting off immediately

Do not warm up the engine with the vehicle at a standstill; it is preferable to set off straight away, driving at moderate engine speeds.

This brings the cold engine to operating temperature as quickly as possible.

## Driving with foresight

Avoid accelerating and braking unnecessarily. Keep an appropriate distance from the preceding vehicle.

Anticipating the road situation and adopting a smooth driving style will reduce fuel consumption.

## Avoid high engine speeds

Basic principle: driving at low engine speeds reduces fuel consumption and wear.

Use 1st gear to drive off. As from 2nd gear, accelerate quickly. Avoid high engine speeds and shift up quickly.

Shift into the highest possible gear when you have reached the desired speed and drive at a constant speed with the lowest possible engine speed.

Pay attention to the shift point indicator in the vehicle, if fitted, see page 88.

## Using overrun mode

When approaching a red traffic light, take your foot off the accelerator and allow the vehicle to roll.

On downward stretches, take your foot off the accelerator and allow the vehicle to roll.

The fuel supply is interrupted when coasting.

## Switching off engine if stopping for a relatively long time

When you stop the vehicle for longer periods, for example at traffic lights, railway crossings or in traffic jams, switch off the engine.

### Auto Start Stop function

The Auto Start Stop function of your vehicle shuts off the engine automatically during a stop.

If the engine is switched off and then started again, the fuel consumption and emissions are reduced compared with a permanently running engine. Savings can be made just by stopping the engine for a few seconds.

Fuel consumption also depends on other factors, such as driving style, road condition,

maintenance or environmental factors, for example.

## Switching off functions that are not necessary at the moment

Functions such as seat heating or heated rear window require a great deal of energy and reduce the range, especially in city traffic and stop-and-go traffic.

Switch these functions off if they are not required.

## Having the maintenance done

Have the vehicle serviced regularly to achieve optimal economy and lifetime. Have maintenance carried out by a Service Partner or a qualified specialist workshop.

Please also see the BMW Maintenance System, see page 191.





## Mobility

To assist you in preserving your car's mobility, this section contains important information on operating fluids, wheels and tyres, maintenance and breakdown assistance.

# Refuelling

## Vehicle equipment

This chapter describes all standard, national and special equipment provided in the model series. Equipment not available in the vehicle is therefore also described, for example the selected special equipment or national version. This also applies to safety-relevant functions and systems. Comply with the relevant national regulations when using the corresponding functions and systems.

## Notes

Before refuelling, observe notes on fuel quality, see page 174.

### ATTENTION

If the range drops below 50 km, approx. 30 miles, the engine could not be supplied anymore with sufficient fuel. Engine functions are not ensured anymore. Danger of damage to property. Refuel in good time. ◀

## Fuel tank cap

### Opening

1. Briefly press rear edge of fuel filler flap.



2. Turn the fuel tank cap anticlockwise.

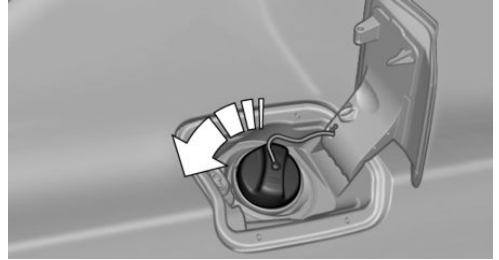

3. Place the fuel tank cap in the holder on the fuel filler flap.

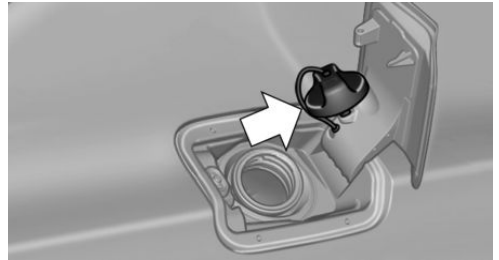

### Closing

1. Fit the tank cap and turn clockwise until it is clearly heard to click into place.
2. Close fuel filler cap.

### WARNING

The retaining strap of the fuel tank cap can be clamped and crushed when screwing closed. This means the cap cannot be closed correctly, and fuel vapours or fuel can emerge. Danger of injury or damage to property. Make sure that the retaining strap does not get trapped and crushed when closing the cap. ◀

### Unlocking fuel filler flap manually

For example, with an electrical fault.

The unlocking mechanism is in the boot.

1. Remove the cover from the right-hand trim panel. To do this, turn the cap.

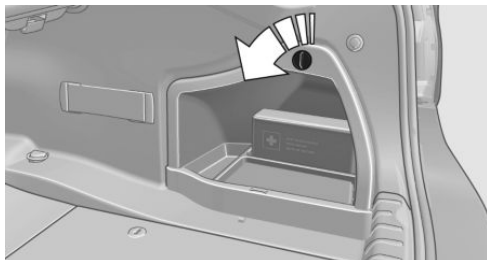

2. Pull the green tag with the fuel pump symbol. Fuel filler flap is unlocked.

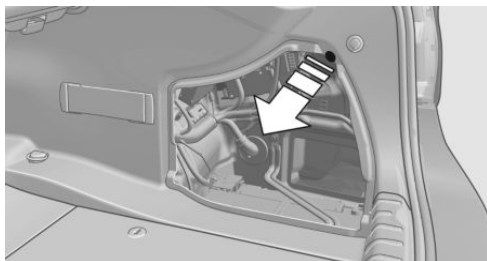

## Note when refuelling



### ATTENTION

Fuels are poisonous and aggressive. Overfilling the fuel tank can damage the fuel system. If it comes into contact with painted surfaces, it can damage them. This pollutes the environment. Danger of damage to property. Avoid overfilling. ◀

When refuelling, insert the filler nozzle fully into the filler neck. Lifting the filler nozzle during refuelling results in the following:

- ▶ The fuel supply being cut off prematurely.
- ▶ Fuel vapour and fumes being fed back less effectively.

The fuel tank is full when the filler nozzle cuts out for the first time.

Comply with the safety regulations displayed at filling stations.

# Fuel

## Vehicle equipment

This chapter describes all standard, national and special equipment provided in the model series. Equipment not available in the vehicle is therefore also described, for example the selected special equipment or national version. This also applies to safety-relevant functions and systems. Comply with the relevant national regulations when using the corresponding functions and systems.

## Fuel quality

### General

Depending on the region, many filling stations sell fuel that is adapted to the conditions in winter or summer. Fuel that is sold in winter facilitates cold starting, for example.

### Note



#### ATTENTION

Even fuels corresponding to the specifications may be of low quality. Engine problems can arise, for example poor engine starting, impaired driving properties or reduced performance. Danger of damage to property. In the case of engine problems, use a different filling station or refuel with a higher octane fuel from a brand manufacturer. ◀

### Petrol

For optimal fuel consumption, the petrol should be sulphur-free or as low in sulphur content as possible.

Fuels labelled on the pump as containing metal must not be used.



#### ATTENTION

Even small quantities of the wrong fuel or wrong fuel additives can damage the fuel system and engine. In addition, the catalytic converter will be permanently damaged. Danger of damage to property. Do not use the following fuel or additives with petrol engines:

- ▶ Leaded petrol.
- ▶ Metallic additives, for example manganese or iron.

After filling the wrong fuel, do not press the start/stop button. Contact a Service Partner or a qualified specialist workshop. ◀

You can fill up with fuels with a maximum proportion of ethanol of 10 %, in other words E10.



#### ATTENTION

Incorrect fuels can damage the fuel system and engine. Danger of damage to property. Do not fill with any fuels that either have a higher ethanol content than recommended or that contain methanol, for example M5 to M100. ◀

The engine has anti-knock control. This means that different petrol grades can be used.

### Petrol grade

Super Plus, with RON 98.

Fill up this fuel so that the nominal performance data values and consumption is achieved.

### Minimum grade

Super with RON 95.



#### ATTENTION

Fuel below the specified minimum quality can impact the engine function or lead to engine damage. Danger of damage to property. Do not refuel petrol below the specified minimum quality. ◀

# Wheels and tyres

## Vehicle equipment

This chapter describes all standard, national and special equipment provided in the model series. Equipment not available in the vehicle is therefore also described, for example the selected special equipment or national version. This also applies to safety-relevant functions and systems. Comply with the relevant national regulations when using the corresponding functions and systems.

## Tyre pressures

### Information for your safety

A tyre's condition and pressure influence the following:

- ▷ Operating life of the tyre.
- ▷ Driving safety.
- ▷ Driving comfort.

### Checking tyre pressures



#### WARNING

A tyre with inadequate or missing tyre inflation pressure impairs driving properties, for example steering and braking. Danger of accidents. Check tyre inflation pressure regularly and adjust as necessary, for example twice a month or before any long journey. ◀

Tyres have a natural, uniform tyre pressure loss.

Tyres heat up when driving and with the temperature of the tyre, the tyre filling pressure increases. The tyre filling pressure data relate to cold tyres or tyres at ambient temperature.

Only check the tyre pressure when the tyres are cold. In other words, after driving for a maximum of 2 km or if the vehicle has been parked for at least 2 hours.

Inflating devices can display a pressure as much as 0.1 bar too low.

With runflat indicator: reinitialise the runflat indicator after adjusting tyre pressures.

With tyre pressure monitor: reset the tyre pressure monitor after adjusting the tyre pressure to a new value.

### Tyre inflation pressures



The tyre inflation pressures for the tyre sizes categorised by the vehicle manufacturer as suitable for the respective vehicle type can be found on the door pillar of the driver's door.

If the speed letter of the tyre cannot be found, the tyre inflation pressure of the corresponding size applies. The tyre inflation pressure data apply to tyres at ambient temperature.

### For Australia/New Zealand



#### WARNING

The inflation pressures on the tyre label are applicable only for tyres explicitly mentioned on the label. Since inflation pressures for tyres that may be covered by the label – by size, speed category and load rating/load index – but not explicitly mentioned on the label may be different. Please obtain adequate inflation pressures in accordance with the tyre manufacturer's specifications at your tyre dealer. ◀

## Tyre sizes

The pressure values apply for the tyre sizes categorised by the vehicle manufacturer as suitable and the tyre makes recommended for the respective vehicle type.

More information regarding wheels and tyres can be enquired with a Service Partner or a qualified specialist workshop.

## Tyre tread

### Summer tyres

The tyre tread depth should not be less than 3 mm, 0.12 in.

Below a tread depth of 3 mm, approximately 0.12 in, there is a high risk of aquaplaning.

### Winter tyres

The tyre tread depth should not be less than 4 mm, approximately 0.16 in.

Below a tread depth of 4 mm, approximately 0.16 in, suitability for vehicle operation in winter is restricted.

### Minimum tread depth

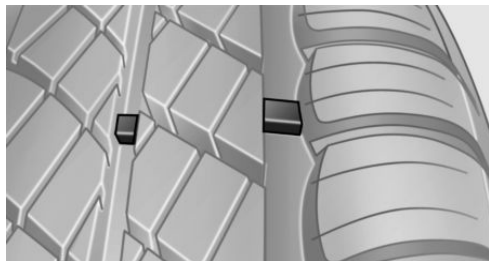

Wear indicators are distributed across the tyre circumference and have the legally prescribed minimum height of 1.6 mm, approximately 0.06 in.

They are identified on the tyre's side wall by TWI, Tread Wear Indicator.

## Tyre damage

### General

Inspect tyres frequently for damage, the presence of foreign bodies and wear.

### Notes

Vehicle behaviour that is an indication of tyre damage or other faults:

- ▷ Unusual vibrations during the journey.
- ▷ Unusual vehicle response, such as pronounced pulling to the left or right.

Damage can be caused by, for example, running over kerbs, road damage etc.



#### WARNING

Damaged tyres can lose tyre inflation pressure, which can lead to loss of control over the vehicle. Danger of accidents. If you get a note about tyre damage during the journey, immediately reduce speed and come to a halt. Have the wheels and tyres checked. To do this, carefully drive to the nearest Service Partner or a qualified specialist workshop. If necessary, have the vehicle towed or transported there. ◀



#### WARNING

Damaged tyres can lose tyre inflation pressure, which can lead to loss of control over the vehicle. Danger of accidents. Do not repair damaged tyres, have them renewed instead. ◀

## Age of tyres

### Recommendation

Irrespective of wear, change tyres after six years at the latest.

### Date of manufacture

On the tyre side wall:

DOT ... 0115: the tyre was made in the 1st week of 2015.

## Replacement of wheels and tyres

### Fitting

Have fitting and balancing performed by a Service Partner or a qualified specialist workshop.

### Wheel and tyre combination

The correct wheel and tyre combination and rim designs for the vehicle can be consulted at a Service Partner or a qualified specialist workshop.

Incorrect wheel and tyre combinations will interfere with the proper functioning of various systems, such as ABS and DSC.

To maintain good vehicle handling, always fit tyres of the same make and tread pattern to all wheels.

After a tyre has been damaged, fit the original wheel and tyre combination again.



#### WARNING

Wheels and tyres that are categorised as unsuitable by the vehicle manufacturer can damage parts of the vehicle, for example by touching the bodywork as a result of tolerances, in spite of having the same nominal size. Danger of accidents. Use wheels and tyres that have been categorised as suitable for the respective vehicle type by the vehicle manufacturer. ◀

## Recommended makes of tyre



Certain makes of tyre are recommended by the manufacturer of your vehicle depending on tyre size. These can be seen by the asterisk on the side wall of the tyre.

### New tyres

New tyres do not achieve their full road grip immediately, for production reasons.

During the first 300 km, 200 miles, drive moderately.

### Retreaded tyres

The manufacturer of your vehicle advises against the use of retreaded tyres.



#### WARNING

Retreaded tyres can have various tyre carcasses. Their durability may be reduced with increasing age. Danger of accidents. Do not use retreaded tyres. ◀

### Winter tyres

For operation on wintry carriageways, winter tyres are recommended.

Although so-called all-season tyres with an M+S label have better winter characteristics than summer tyres, they do not normally match the performance of winter tyres.

### Maximum speed of winter tyres

If the vehicle is capable of speeds higher than the speed permitted for the winter tyres, an information sticker stating the maximum permit-

ted speed for the tyres fitted must be displayed in the driver's field of view. The sticker is available from a Service Partner or a qualified specialist workshop.

If winter tyres are fitted, observe and comply with the respectively permitted maximum speed.

### Interchanging front and rear wheels

The manufacturer of your vehicle advises against interchanging the front and rear wheels. This could impair vehicle handling

Such a change is not permitted in vehicles with different tyre or rim dimensions on the front and rear axles.

### Tyre storage

Store wheels and tyres in a cool, dry and preferably dark place when not in use.

Protect tyres against contamination from oil, grease and fuel.

Do not exceed the maximum tyre pressure indicated on the tyre's side wall.

## Remedying flat tyres

### Safety measures

- ▷ Park the vehicle on a solid surface and as far away from moving traffic as possible.
- ▷ Switch on hazard warning lights.
- ▷ Protect the vehicle against rolling, by applying the parking brake.
- ▷ Engage the steering wheel lock in the straight ahead position of the wheels.
- ▷ Allow all vehicle occupants get out of the vehicle and guide them out of the danger area, for example behind the crash barrier.
- ▷ Set up warning triangle an appropriate distance away.

## Mobility system

### Principle

With the mobility system, minor tyre damage can be quickly sealed, to allow you to drive on. To do that, liquid sealant is pumped into the tyres which encloses the damage from the inside when it hardens.

The compressor can be used to check the tyre inflation pressure.

### Notes

- ▷ Please observe the notes on the application of the Mobility system which are on the compressor and the sealant container.
- ▷ Applying the Mobility system can be ineffective for tyre damage as from a size of approximately 4 mm.
- ▷ Contact a Service Partner or a qualified specialist workshop if you are unable to put the tyre back in operation.
- ▷ If possible, foreign matter that has penetrated the tyre should remain inside the tyre.
- ▷ Remove the speed limit sticker from the sealant container and attach to the steering wheel.
- ▷ Using sealants can damage the TPM wheel electronics. If sealant is used, check the electronics as soon as you get an opportunity and have them replaced if necessary.



### DANGER

A blocked exhaust pipe or inadequate ventilation can allow harmful exhaust fumes to penetrate the vehicle. The exhaust gas contains carbon monoxide, which is colourless and odourless, but highly toxic. In enclosed spaces, the exhaust fumes can also build up outside the vehicle. Danger of fatal injury. Keep the exhaust pipe clear and ensure sufficient ventilation. ◀

### Storage

Mobility system is located under boot floor.

## Sealant container



- ▷ Sealant container, arrow 1.
- ▷ Filler hose, arrow 2.

Note the use-by date on the sealant container.

## Compressor

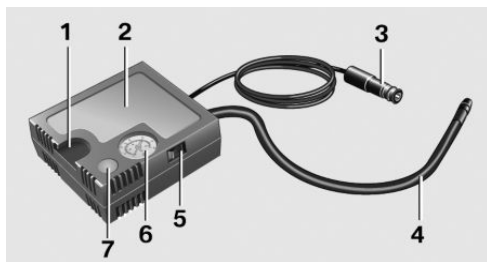

- 1 Mounting for cylinder
- 2 Compressor
- 3 Plug/cable for socket
- 4 Connecting hose
- 5 On/Off button
- 6 Tyre inflation pressure display
- 7 Reduce tyre inflation pressure

## Filling with sealing compound

1. Shake the sealant container.



2. Remove the connecting hose entirely from the compressor housing. Do not kink the hose.

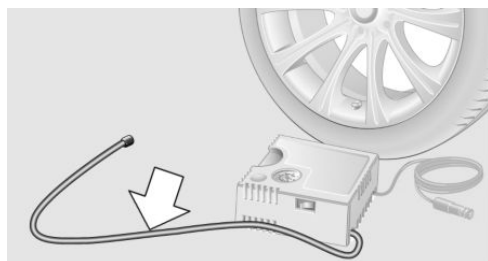

3. Bolt the connecting hose onto the connector of the sealant container.

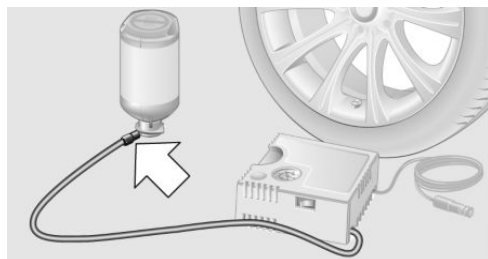

4. Insert the upright sealant container into the compressor housing.

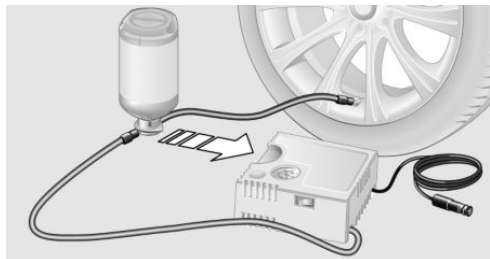

5. Screw the filler hose of the sealant container onto the tyre valve of the faulty wheel.

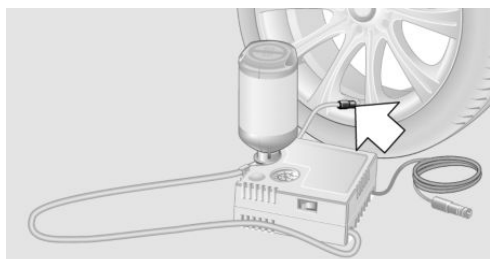

6. Insert the plug into the socket on the inside of the vehicle while the compressor is switched off.

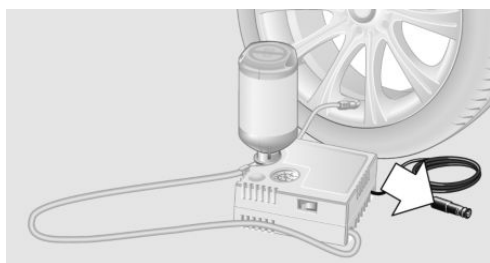

7. Switch on the compressor with the ignition switched on or the engine running.

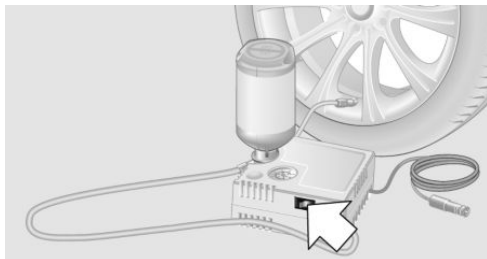

**⚠ ATTENTION**

The compressor can overheat if operated for too long. Danger of damage to property. Do not let the compressor run for longer than 10 minutes. ◀

Let the compressor run for approximately three to 8 minutes to fill the sealing compound and achieve a tyre inflation pressure of approximately 2.5 bar.

The tyre inflation pressure may rise to approximately 5 bar during the filling process of the sealing compound. Do not switch off the compressor during this step.

If it does not reach a tyre inflation pressure of 2 bar:

1. Switch off compressor.
2. Remove the filler hose from the wheel.
3. Drive forwards and backwards by 10 m, approximately 400 inches to distribute the sealant in the tyre.
4. Re-inflate the tyre with the compressor.  
Contact a Service Partner or a qualified specialist workshop if the device does not reach a tyre inflation pressure of 2 bar.

**Storing Mobility system**

1. Remove the filler hose of the sealant container from the wheel.
2. Remove the connecting hose of the compressor from the sealant container.

3. Take the filler hose of the sealant container that was previously connected to the tyre valve and connect it to the free connection on the sealant container.

This can prevent sealant residues from escaping from the container.

4. Pack empty sealant container to avoid soiling in the boot.
5. Store Mobility system in the vehicle again.

### Spreading sealant compound

Immediately drive for approximately 10 km/5 mi to evenly distribute the sealing compound in the tyre.

Do not exceed a speed of 80 km/h/50 mph.

If possible, do not drive slower than 20 km/h/12 mph.

### Correcting the tyre inflation pressure

1. Stop in a suitable area.
2. Bolt the connecting hose of the compressor directly onto the tyre valve.
3. Insert the plug into the socket on the inside of the vehicle.
4. Correct tyre inflation pressure to 2.5 bar.
  - ▷ Increase pressure: switch on the compressor with the engine running or the ignition switched on.
  - ▷ Reduce pressure: press the button on the compressor.

### Continuing with journey

Do not exceed maximum permitted speed of 80 km/h, approximately 50 mph.

Reinitialise runflat indicator.

Reinitialise Tyre Pressure Monitor.

Have the punctured tyre and the sealant container of the Mobility system replaced as soon as possible.

## Snow chains

### Fine-link snow chains

Only certain fine-link snow chains have been tested, found safe for use in traffic, and categorised as suitable by the manufacturer of your vehicle.

Information regarding suitable snow chains is available from a Service Partner or a qualified specialist workshop.

### Using

Snow chains may only be used in pairs on the rear wheels with tyres of the following sizes:

- ▷ 255/40 R 18.
- ▷ 255/35 R 19.

Observe the snow chain manufacturer's notes.

Ensure that the snow chains are always adequately taut. Re-tighten them if necessary in accordance with the chain manufacturer's instructions.

Do not initialise the runflat indicator with snow chains fitted, as the instrument might otherwise issue an incorrect reading.

Do not initialise the Tyre Pressure Monitor with snow chains fitted, as the instrument might otherwise issue an incorrect reading.

When driving with snow chains, activate M Dynamic Mode briefly if necessary.

### Maximum speed with snow chains

When snow chains are fitted, do not exceed 50 km/h, 30 mph.

# Engine compartment

## Vehicle equipment

This chapter describes all standard, national and special equipment provided in the model series. Equipment not available in the vehicle is therefore also described, for example the se-

lected special equipment or national version. This also applies to safety-relevant functions and systems. Comply with the relevant national regulations when using the corresponding functions and systems.

## Engine compartment quick reference guide

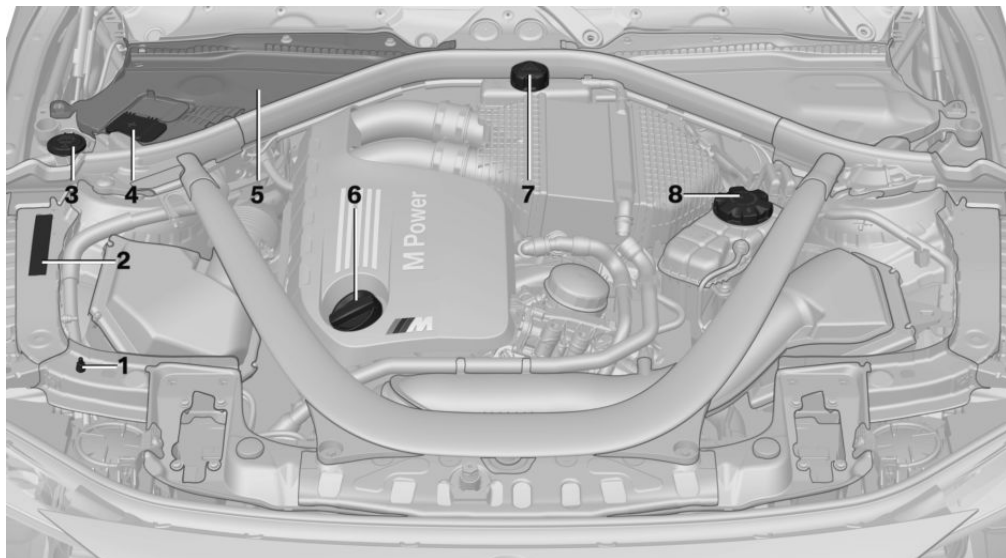

- |  |                                       |
|--|---------------------------------------|
| 1 Starting assistance, negative battery terminal | 5 Engine compartment fuse box         |
| 2 Vehicle identification number                  | 6 Oil filler neck                     |
| 3 Reservoir for washer fluid                     | 7 Coolant tank for charge air cooling |
| 4 Starting assistance, positive battery terminal | 8 Coolant tank for engine cooling     |

## Bonnet

### Notes

**!** **WARNING**  
Incorrectly performed work in the engine compartment can damage components and lead to a safety risk. Danger of accident or damage to property. Have work in the engine compartment carried out by a Service Partner or a qualified specialist workshop. ◀

**!** **WARNING**  
The engine compartment contains moving components. Certain components can also move in the engine compartment when the vehicle is switched off, for example the radiator fan. Danger of injury. Do not reach into the area of moving parts. Keep articles of clothing and hair away from moving parts. ◀

**!** **ATTENTION**  
When wipers are folded away from the windscreen, they can be trapped when the bonnet is opened. Danger of damage to property. Before opening the bonnet, make sure that the wipers with wiper blades fitted are in contact with the windscreen. ◀

**!** **WARNING**  
The bonnet has projecting parts on the inside, for example locking hooks. Danger of injury. When the bonnet is open, watch out for projecting parts and keep these areas clear. ◀

**!** **ATTENTION**  
When closing, the bonnet must audibly click into place. Additional pushing can damage the bonnet. Danger of damage to property. Open and close the bonnet once more. Avoid additional pushing. ◀

**!** **WARNING**  
If the bonnet is not correctly locked, it can come open during the journey and impair visibility. Danger of accidents. Stop immediately and close the bonnet correctly. ◀

**!** **WARNING**  
Parts of the body can become trapped when opening and closing the bonnet. Danger of injury. When opening and closing, make sure that the area of movement of the bonnet is free. ◀

### Opening bonnet

1. Pull lever, arrow 1.  
Bonnet is released.

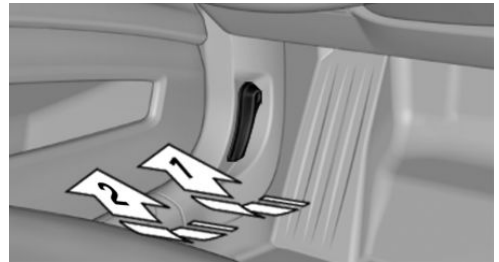

2. After releasing the lever, pull lever again, arrow 2.  
Bonnet is opened.

### Indicator and warning lamps

With the bonnet unlocked, a Check Control message is shown.

## Closing bonnet

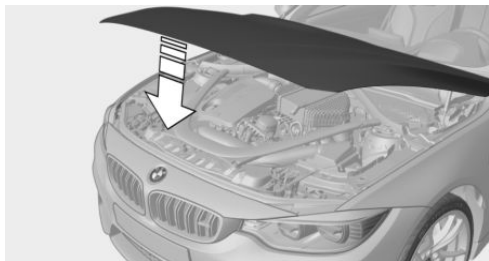

Close bonnet firmly.

The bonnet must audibly engage into place on both sides.

# Engine oil

## Vehicle equipment

This chapter describes all standard, national and special equipment provided in the model series. Equipment not available in the vehicle is therefore also described, for example the selected special equipment or national version. This also applies to safety-relevant functions and systems. Comply with the relevant national regulations when using the corresponding functions and systems.

## General

The engine oil consumption depends on the driving style and operating conditions.

Engine oil consumption can be increased, for example, in the following situations:

- ▶ Dynamic driving style.
- ▶ Running in the engine.
- ▶ Engine idling.
- ▶ Use of engine oil grades categorised as unsuitable.

Therefore check the engine oil level regularly after each time you fill up with fuel.

With dynamic driving, for example, rapid cornering, the system cannot make any oil measurement. With this driving mode, the engine oil is measured using a detailed measurement, see page 186.

The vehicle has electronic oil measurement.

Electronic oil measurement has two measurement principles:

- ▶ Status display
- ▶ Detailed measurement

## Electronic oil measurement

### Status display

#### Principle

The engine oil level is electronically monitored when travelling and shown on the Control Display.

If the engine oil level reaches the minimum, a check control message is shown.

#### Requirements

A current measurement is available after approximately 30 minutes of driving. With a shorter trip, the status of the last sufficiently long trip is shown.

When frequently making short trips, regularly take a detailed measurement.

### Displaying engine oil level

On the Control Display:

1. "Vehicle information"
2. "Vehicle status"
3.  "Engine oil level"

### Messages for the engine oil level



#### ATTENTION

Too little engine oil causes engine damage. Danger of damage to property. Immediately replenish engine oil. ◀

Ensure not to top up with too much engine oil.



#### ATTENTION

Too much engine oil can damage the engine or the catalytic converter. Danger of damage to property. Do not top up with too much engine oil. If you fill too much engine oil, have the excess extracted by a Service Partner or a qualified specialist workshop. ◀

Different messages are shown on the display, depending on the engine oil level. Follow these messages.

If there is too little engine oil, within the next 200 km, approximately 120 miles top up engine oil, see page 186.

## Detailed measurement

### Principle

In the detailed measurement, the engine oil level is checked and shown on a scale.

If the engine oil level reaches the minimum, a Check Control message is shown.

During the measurement, the idle speed is slightly raised.

### Requirements

- ▷ Vehicle is on an even road.
- ▷ Manual gearbox: gear lever in neutral position, clutch and accelerator pedal not depressed.
- ▷ M double clutch transmission: selector lever in selector lever position N and accelerator pedal not depressed.
- ▷ Engine is running and is at operating temperature.

### Carrying out a detailed measurement

Carry out a detailed measurement of the engine oil level:

1. "Vehicle information"
2. "Vehicle status"
3.  "Measure engine oil level"
4. "Start measurement"

The engine oil level is checked and shown on a scale.

Duration: approximately 1 minute.

## Adding engine oil

### Notes



#### ATTENTION

Too little engine oil causes engine damage. Danger of damage to property.

Top up the engine oil within the next 200 km, approximately 120 miles. ◀



#### ATTENTION

Too much engine oil can damage the engine or the catalytic converter. Danger of damage to property. Do not top up with too much engine oil. If you fill too much engine oil, have the excess extracted by a Service Partner or a qualified specialist workshop. ◀



#### WARNING

Service products, for example oils, greases, coolants and fuels, can contain substances that are harmful to health. Danger of injury or life. Comply with the notes on the containers. Do not allow service products to come into contact with clothing, skin eyes. Do not pour service products into other bottles. Keep service products out of the reach of children. ◀

### General

Do not top up engine oil unless message is displayed in instrument cluster. The top-up amount is specified in the message on the instrument cluster.

Switch off the ignition and securely stop the vehicle before topping up with engine oil.

Spilled engine oil can damage carbon parts. Wipe up spilled engine oil with a lint-free cloth.

### Overview

The oil filler neck is in the engine compartment, see page 182.

## Opening the oil filler neck

1. Open bonnet, see page 183
2. Open the oil filler neck anticlockwise.

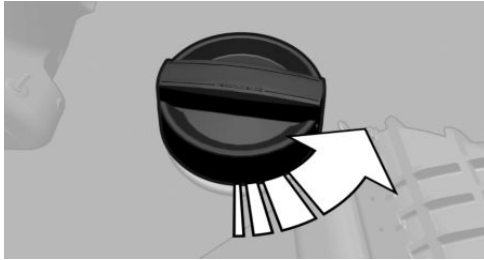

3. Add engine oil.

## Engine oil types for topping up

### Notes

**ATTENTION**  
Oil additives can damage the engine. Danger of damage to property. Do not use oil additives. ◀

**ATTENTION**  
Incorrect engine oil can lead to engine malfunctions and damage. Danger of damage to property. When selecting the engine oil, make sure that the viscosity class of the engine oil is correct. ◀

The engine oil quality is decisive for the lifetime of the engine.

Several engine oil types are not available in all countries.

### Viscosity classes

When selecting an engine oil, ensure that the engine oil has viscosity classes SAE 0W-40. Alternatively, engine oils with viscosity class SAE 0W-30 can be used.

Further information regarding suitable oil specifications and viscosities of engine oils

can be enquired with a Service Partner or a qualified specialist workshop.

### Suitable engine oil grades

Engine oils with following oil specifications can be topped up:

#### Oil specification

BMW Longlife-01.

BMW Longlife-01 FE.

BMW Longlife-04.

BMW Longlife-12 FE.

Further information regarding suitable oil specifications and viscosities of engine oils can be enquired with a Service Partner or a qualified specialist workshop.

### Alternative engine oil types

If suitable engine oils are not available, up to 1 litre, approx. 2 pints of an engine oil with the following oil specification can be used for topping up:

#### Oil specification

ACEA A3/B4.

## Oil change

**ATTENTION**  
Engine oil not replaced in time can lead to increased engine wear and thus engine damage. Danger of damage to property. Do not exceed the service date indicated in the vehicle. ◀

The manufacturer of the vehicle recommends having the engine oil changed by a Service Partner or a qualified specialist workshop.

BMW recommends  
**Original BMW Engine Oil.**

# Coolant

## Vehicle equipment

This chapter describes all standard, national and special equipment provided in the model series. Equipment not available in the vehicle is therefore also described, for example the selected special equipment or national version. This also applies to safety-relevant functions and systems. Comply with the relevant national regulations when using the corresponding functions and systems.

## General

The vehicle has two coolant tanks located in the engine compartment.

To guarantee operational safety of the vehicle, always check the coolant levels of both coolant tanks.

## Notes

### WARNING

If the cooling system is opened when the engine is hot, coolant can escape and cause scalds. Danger of injury. Only open the cooling system when the engine has cooled down. ◀

### WARNING

Additives are harmful to health and incorrect additives can damage the engine. Danger of injury and damage to property. Do not allow additives to come into contact with clothing, skin or eyes, and do not swallow them. Only use suitable additives. ◀

Coolant is a mixture of water and an additive.

Not all commercially available additives are suitable for the vehicle. Information regarding suitable additives is available from a Service Partner or a qualified specialist workshop.

## Coolant level

### Overview

Depending on the engine version, the coolant tank is located on the right or left of the engine compartment.

### Checking

1. Allow the engine to cool down.
2. Turn cap on coolant tank slightly anti-clockwise until it starts to open, then allow the pressure to escape.

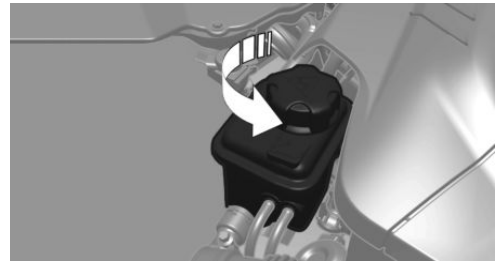

3. Open cap on coolant tank.
4. The coolant level is correct if it is between the Min. and Max. marks in the filler neck.



### Topping up

1. Allow the engine to cool down.
2. Turn the cap on the coolant tank slightly anti-clockwise until it starts to open, then

allow the pressure to escape before opening it fully.

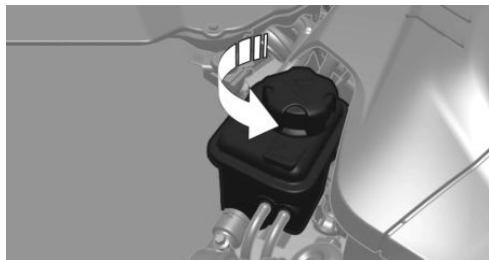

3. If necessary, slowly top up to the correct level; do not overfill.
4. Tighten cap.
5. Have the cause of coolant loss rectified as soon as possible.

## Disposal



When disposing of coolant and coolant additives, comply with the relevant environmental protection regulations.

# Maintenance

## Vehicle equipment

This chapter describes all standard, national and special equipment provided in the model series. Equipment not available in the vehicle is therefore also described, for example the selected special equipment or national version. This also applies to safety-relevant functions and systems. Comply with the relevant national regulations when using the corresponding functions and systems.

## BMW Maintenance System

The maintenance system points out the necessary maintenance measures and so supports in maintaining the road and operational safety of the vehicle.

Scopes and intervals may vary depending on national version. Replacement work, spare parts, operating materials and wear material are calculated separately. Further information is available from a Service Partner or a qualified specialist workshop.

## Condition Based Service, CBS

Sensors and advanced algorithms monitor the conditions in which your vehicle is used. Condition Based Service uses this information to calculate the maintenance requirements.

The system thus enables adaptation of the scope of maintenance to the individual usage profile.

Detailed information on service requirements, see page 87, can be displayed at the Control Display.

## Service data in the remote control

Information on maintenance requirements is continually saved in the remote control. The Service Partner or a qualified specialist workshop can read out this data and suggest an optimised maintenance scope for your vehicle.

This is why you should hand over the remote control that was last used for driving to your service advisor with the vehicle.

## Periods out of use

Immobilisation periods with the vehicle battery disconnected are not taken into account.

Updating the time-dependent maintenance scope such as brake fluid and any engine oil and microfilter or activated carbon filter can be done by a Service Partner or a qualified specialist workshop.

## Service history

Have maintenance and repair carried out by a Service Partner or a qualified specialist workshop.

The maintenance work carried out is entered in the proof of maintenance and the vehicle data. The entries are, just like a service booklet, evidence of regular maintenance.

If an entry is made in the electronic service history of the vehicle, service-relevant data is not only saved in the vehicle but also on the central IT systems of BMW AG, Munich.

The data entered in the electronic service history can also be viewed by the new vehicle owner after a change of vehicle owner. In addition, all Service Partners and other authorised and qualified specialist workshops can view the data entered in the electronic service history.

The vehicle owner can contact his/her Service Partner or a qualified specialist workshop to object to the entry in the electronic service history, the associated data storage in the vehicle and data transfer to the vehicle manufacturer, in relation to his/her time as the vehicle owner. In that case, no entry is made in the electronic service history of the vehicle.

Maintenance entered is shown on the Control Display, see page 88.

## For Australia/New Zealand: maintenance

No maintenance work other than normal maintenance is required to keep the emission levels of your vehicle within the design limits.

## Socket for on-board diagnosis, OBD

### Note



#### ATTENTION

Incorrect use of the on-board diagnosis socket can result in malfunctions in the vehicle. Danger of damage to property. The on-board diagnosis socket is only allowed to be used by a Service Partner, a qualified specialist workshop or other authorised persons. ◀

### Position

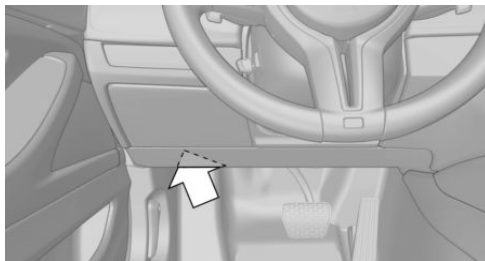

The OBD socket for checking components definitive in terms of the composition of the exhaust emissions is on the driver's side.

### Emissions



- ▶ The warning light flashes:  
Engine malfunction that could damage the catalytic converter. Have the vehicle checked as soon as possible.
- ▶ The warning light is illuminated:  
Deterioration of exhaust emissions. Have the vehicle checked as soon as possible.

## Recycling

The manufacturer of your vehicle recommends handing the vehicle in at a take-back point nominated by the manufacturer at the end of its life cycle. The regulations concerning the returning of end-of-life vehicles may vary from country to country. Further information is available from a Service Partner or a qualified specialist workshop.

# Replacing parts

## Vehicle equipment

This chapter describes all standard, national and special equipment provided in the model series. Equipment not available in the vehicle is therefore also described, for example the selected special equipment or national version. This also applies to safety-relevant functions and systems. Comply with the relevant national regulations when using the corresponding functions and systems.

## On-board tool kit

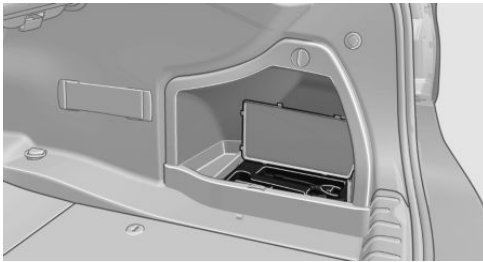

The on-board toolkit is located in a compartment on the right in the boot. Open the cover.

## Replacing the wiper blades

### Note



#### ATTENTION

The windscreen can be damaged if the wiper arm drops onto the windscreen without wiper blades fitted. Danger of damage to property. Hold the wiper arm firmly when changing the wiper blades and do not put the wipers into contact with the windscreen unless wiper blades are fitted. ◀

## Wiper blades, replacing

1. To replace the wiper blades, place the wipers in the fold-out position, see page 72.
2. Fold out wiper arm and hold firm.
3. Press together securing spring, arrow 1, and fold out the wiper blade, arrow 2.

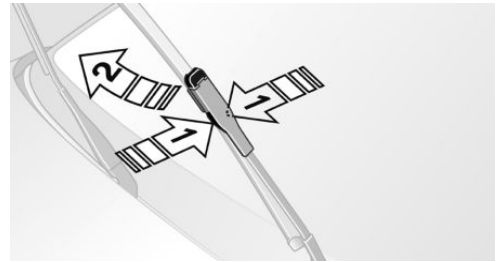

4. Take the wiper blade forwards out of the fitting.
5. Insert new wiper blade in the opposite sequence until it engages.
6. Fold in wipers.



#### ATTENTION

When wipers are folded away from the windscreen, they can be trapped when the bonnet is opened. Danger of damage to property. Before opening the bonnet, make sure that the wipers with wiper blades fitted are in contact with the windscreen. ◀

## Replacing bulbs

### Information

#### Lights and bulbs

Lights and bulbs are an important aspect of driving safety.

The manufacturer of the vehicle recommends that you have the corresponding work carried out by a Service Partner or a qualified special-

ist workshop, if you are not familiar with it or it is not described here.

A box containing spare bulbs is available from a Service Partner or a qualified specialist workshop.

 **WARNING**

Lamps can become hot during operation. Contact with the lamps can lead to burns. Danger of injury. Only replace lamps in cooled-down condition. ◀

 **WARNING**

Short circuits can occur when working on switched on lighting systems. Danger of injury or damage to property. Switch the respective lights off when working on the lighting system. Observe the possibly enclosed notes of the lamp manufacturer. ◀

 **DANGER**

High voltages can be applied to the lighting system. Danger of fatal injury. Have work on the lighting system including replacing the lamps performed by a Service Partner or a qualified specialist workshop. ◀

 **ATTENTION**

Dirty lamps have a reduced lifetime. Danger of damage to property. Do not touch the glass of new lamps with your bare hands. Use a clean tissue, cloth or similar, or hold the bulb by its base. ◀

### Light-emitting diodes, LEDs

Some equipment versions have light-emitting diodes behind a cover as a light source.

These resemble conventional lasers and are classified by legislation as Class 1 light-emitting diodes.

 **WARNING**

Excessively intense brightness can irritate or harm the retina of the eye. Danger of injury. Do not look directly at the headlights or

other light sources for a sustained period. Do not remove covers from LEDs. ◀

### Headlight glass

During cool or humid weather, the exterior lights can mist over. When driving with the light switched on, the condensation disappears after a short time. There is no need to replace the headlight glass.

If the headlights do not demist, even when driving with the lights switched on and increasing moisture builds up, for example water droplets in the lights, have these checked by a Service Partner or a qualified specialist workshop.

### Headlight adjustment

The adjustments of the headlight can be affected by changing lights and bulbs. Have the headlight adjustment checked and if necessary corrected by a Service Partner or a qualified specialist workshop after changing lights and lamps.

### Front lights, replacing the bulbs

#### Xenon headlight

#### Notes

 **DANGER**

High voltages can be applied to the lighting system. Danger of fatal injury. Have work on the lighting system including replacing the lamps performed by a Service Partner or a qualified specialist workshop. ◀

These bulbs have a very long service life and are highly unlikely to fail. Frequent switching on and off shortens the service life.

## Headlights

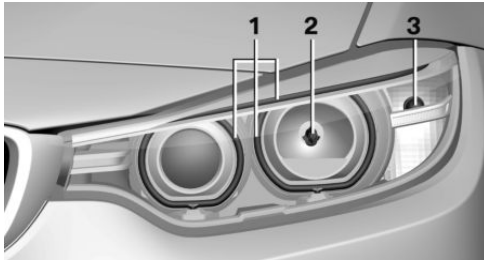

- 1 Side lights/daytime driving lights
- 2 Low-beam headlights/high-beam headlights/headlight flasher
- 3 Turn indicator

The low-beam headlights and high-beam headlights use xenon technology.

The side lights and daytime driving lights use LED technology.

Contact a Service Partner or a qualified specialist workshop in the case of a defect.

### Turn indicator

Follow the general information, see page 193. 21 Watts bulb, PY21W.

1. Use screwdriver from on-board toolkit to loosen the three screws in wheel arch, arrows 1.

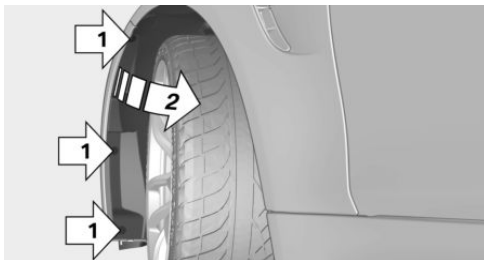

2. Lift wheel arch trim and hold, arrow 2.

3. Turn the bulb holder anticlockwise and remove.

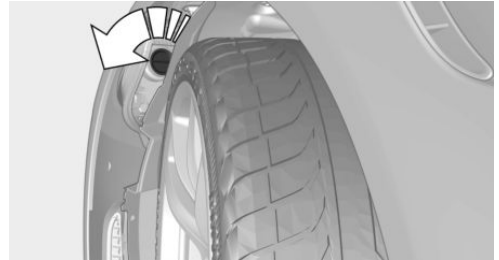

4. Press the bulb gently into the fitting, turn anticlockwise and remove.
5. Fit new bulb and bulb holder in the reverse sequence.
6. Secure wheel arch trim again.

## LED headlights

### Light-emitting diodes, LEDs

With LED headlights all front lights and side turn indicators use LED technology.

Contact a Service Partner or a qualified specialist workshop in the case of a defect.

## Headlights

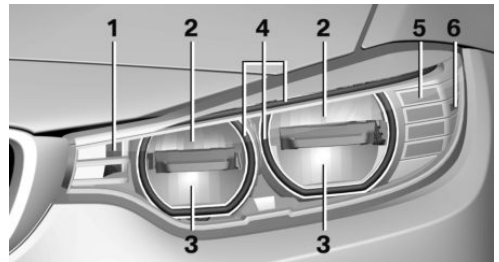

- 1 Cornering lights
- 2 Low-beam headlights/light flasher
- 3 High-beam headlights/headlight flasher
- 4 Side lights/daytime driving lights
- 5 Turn indicator
- 6 Side marking lights

In the event of a defect, contact the Service Centre.

### Turn indicator in exterior mirror

Turn indicators in the exterior mirrors are designed in the LED technology. Contact a Service Partner or a qualified specialist workshop in the case of a defect.

## Rear lights, replacing the bulbs

### Overview

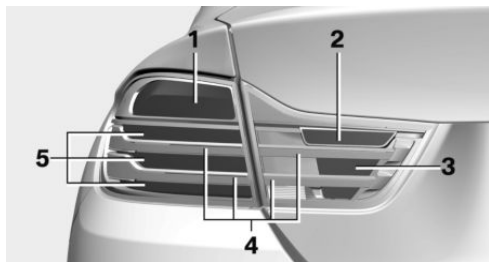

- 1 Turn indicator
- 2 Reversing lights
- 3 Rear fog lights
- 4 Tail lights
- 5 Brake light

## Replacing bulbs of outer rear lights

### General

Follow the general information, see page 193.

Turn indicator: 21 watt bulb, P21WLL.

Brake lights: 21 Watts, H21WLL bulb.

Tail lights are designed in LED technology. Contact a Service Partner or a qualified specialist workshop in the case of a defect.

### Removing rear light

1. Open boot lid.
2. Undo fastening pin for the cover, arrow 1, with the screwdriver of the on-board toolkit and remove.

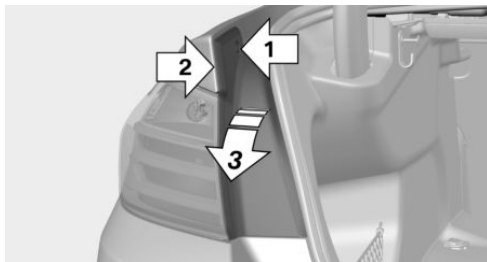

3. Press in the catch with the screwdriver from the on-board toolkit, arrow 2, and remove the cover, arrow 3.
4. Undo both nuts with the handle of the screwdriver, arrows.

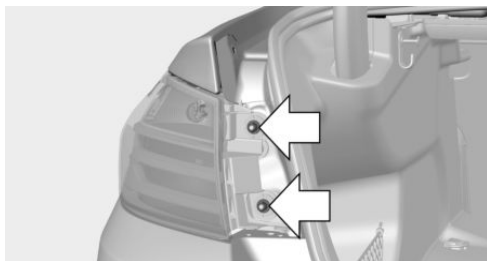

5. Grasp the rear lights on the inner edge, following arrow 1, and carefully pull back and out, arrow 2. In so doing, hold against your free hand, so that the tail light does not undo jerkily. Check that the foam rub-

ber sealing ring on the linkage of the centring is plugged in.

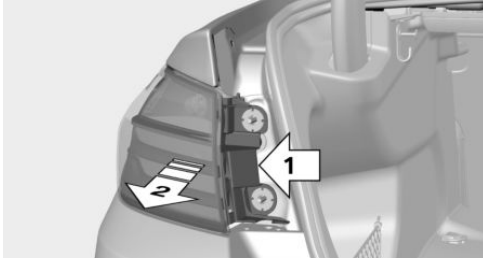

- Undo upper rest on the plug of the connecting cable and remove plug from the bulb holder.

### Replacing bulbs

- Undo the three fastenings, arrow 1, on the bulb holder and remove the bulb holder from the tail light, arrow 2.

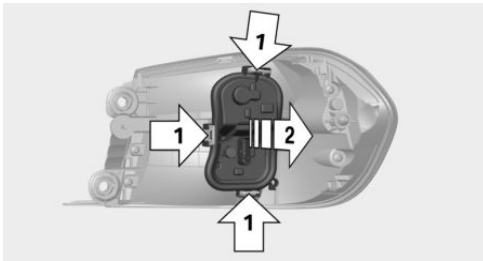

- Press the faulty bulb gently into the fitting, turn anticlockwise and remove.
- To use the new bulb and attach the bulb holder, proceed in the opposite sequence. Ensure that the bulb holder engages in all fastenings.

### Installing rear light

- Connect the connecting cable to the tail light and fix into the bracket of the bulb holder.
- Ensure that the foam rubber sealing ring on the linkage of the centring, arrow 2, is present and undamaged.

- Put the rear light outer onto the rubber bearing, arrow 1, and into the centring, arrow 2, and push firmly. Ensure that the tail light engages in the rubber bearing.



- Screw on rear light with both nuts.
- Insert cover and secure. Ensure that the sealing hose is not jammed.

### Lights in the boot lid

#### General

Follow the general information, see page 193.

Reversing lights: 16 Watts bulb, PW16W

Rear fog lights: 21 Watts bulb, H21W.

All other lights in the boot lid use LED technology. Contact a Service Partner or a qualified specialist workshop in the case of a defect.

#### Access to the lights

- If necessary remove warning triangle, see page 203, and bracket with the screwdriver from the on-board toolkit, see page 193.
- Remove emergency release and cable from the handle.

- Undo the fastenings of the trim with the screwdriver from the on-board toolkit and pull out completely.

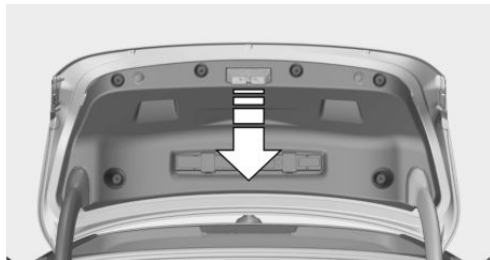

- Push together hinged cover, see arrows, to undo the clips.

Firmly hold cover and pull hinged cover down and remove.

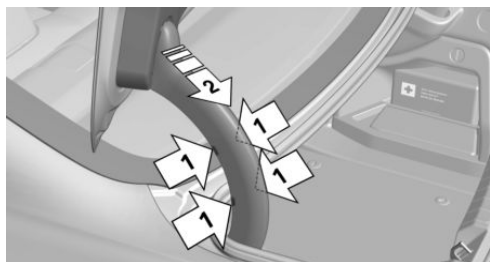

- Carefully remove the trim from the boot lid, first on the edge and then in the area of the recessed handles. Ensure that the trim does not get caught.
- Carefully unclip the trim.

### Changing rear light and rear fog light

- Undo the lower fastening, arrow 1.



- Undo the upper fastening, arrow 2. To do this, push middle stop inwards, and two outer stops outwards.

Pull off bulb holder, arrow 3.

- Undo faulty lamp for reversing and rear fog lights from the socket by turning anti-clockwise.

- Install new bulb.

### Installing lamp holder

- Plug both contacts, arrow 1, into the connectors, arrow 2.

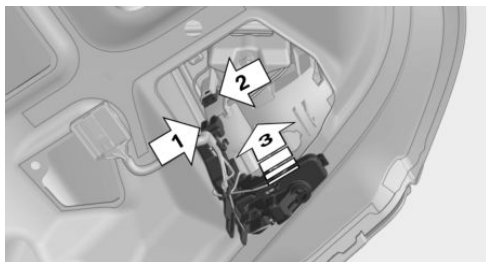

- Press on the lamp holder, arrow 3. Ensure that both fastenings engage on the outside.
- Clip the trim back onto the boot lid and fasten.
- Place the hinge cover back onto the hinge and push up until the fastening pin engaged. Close the clips.

5. Install the cable on the handle of the emergency release and engage the handle into the fastening.
6. Fit the bracket for the warning triangle.
7. Attach the warning triangle.

### Tail lights, number plate lights and centre brake light

These lights use LED technology. Contact a Service Partner or a qualified specialist workshop in the case of a defect.

## Changing a wheel

### Notes

When using sealants, immediate wheel change in the event of loss of tyre pressure in case of puncture is not required.

As a result, no spare wheel is available.

The tools for changing wheels are available as optional accessories from a Service Partner or a qualified specialist workshop.

### Jack mounting points

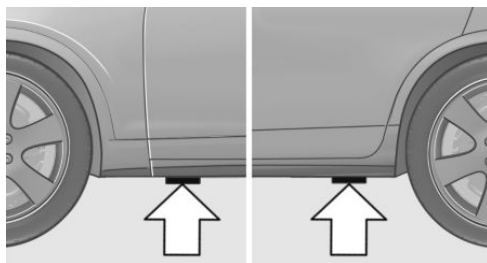

The jack mounting points are located in the illustrated positions.

### Thiefproof wheel studs

The adapter of the thiefproof wheel studs can be found in the tool kit or in an oddments tray in the tool kit.

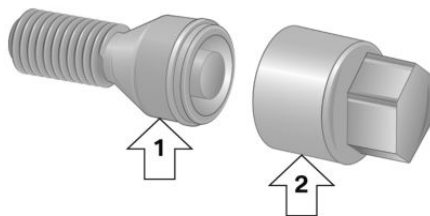

- ▷ Wheel stud, arrow 1.
- ▷ Adapter, arrow 2.

### Removing

1. Place the adapter on the wheel stud.
2. Unscrew wheel stud.

After reattaching the wheel stud, remove the adapter again.

## Car battery

### Maintenance

The battery is maintenance-free.

More information regarding the battery can be enquired with a Service Partner or a qualified specialist workshop.

### Replacing the battery



#### ATTENTION

Vehicle batteries that have been categorised by the manufacturer of the vehicle as unsuitable can damage systems, or prevent functions from being carried out. Danger of damage to property. Only use vehicle batteries that have been classified as suitable by the vehicle manufacturer. ◀

When the vehicle battery has been changed, have the battery registered on the vehicle by a Service Partner or a qualified specialist workshop to ensure that all comfort functions are fully available and any appropriate Check Control messages are no longer displayed.

## Recharging the battery

### General

Ensure the battery is sufficiently charged to guarantee the entire lifetime of the battery.

In the following cases, charging the battery is necessary:

- ▷ When making frequent short trips.
- ▷ When leaving for periods of longer than one month.

### Notes



#### ATTENTION

Unsuitable external chargers can damage the vehicle. Danger of damage to property. Use chargers that have been categorised as suitable for the respective vehicle type by the vehicle manufacturer. Observe the maximum charge voltage. ◀

Maximum charge voltage: 14.4 Volt.



#### ATTENTION

Battery chargers for the vehicle battery can operate with high voltages and high currents, which can overload or damage the 12 volt on-board network. Danger of damage to property. Only connect battery chargers for the vehicle battery to the jump-starting connections in the engine compartment. ◀

## Jump-starting connections

Recharge the battery only with the engine stopped, via the jump-starting connections, see page 204, in the engine compartment.

## Charger

Chargers developed especially for the vehicle and attuned to the on-board network can be obtained from Service Partner or a qualified specialist workshop.

## Power failure

Following a temporary electrical power outage, some equipment will have to be reinitialised or individual settings will need to be updated, for example:

- ▷ Seat and mirror memory: re-save positions.
- ▷ Time: update.
- ▷ Date: update.
- ▷ Glass Roof and sun blind: initialise system, see page 47.

## Disposing of the old battery



Dispose of old batteries at a Service Partner or a qualified specialist workshop or hand them into an authorised collecting point.

## Fuses

### Notes



#### WARNING

Incorrect or repaired fuses can overload electrical cables and components. Fire risk. Do not repair blown fuses or renew them by fuses with a different colour or amp rating. ◀

Plastic tweezers and details of the fuse assignment can be found with the fuses in the boot.

## In the engine compartment

1. Undo the three screws of the cover, arrow 1, with the on-board tool.

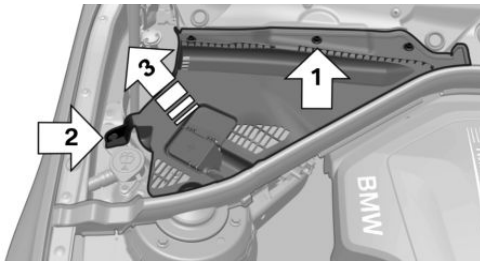

2. Pull fastening upwards, arrow 2.
3. Remove cover from the side, arrow 3.
4. Press on the four fastenings and remove the lid.

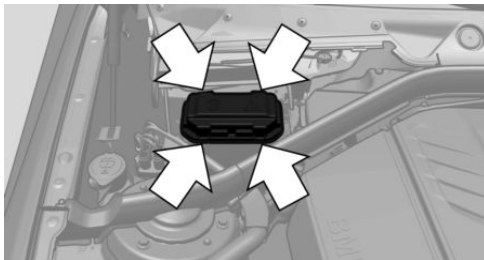

## Attaching covers

1. When attaching the lid, ensure that all four fastenings are engaged.
2. Attach cover under the rubber lip and then thread between the webs.

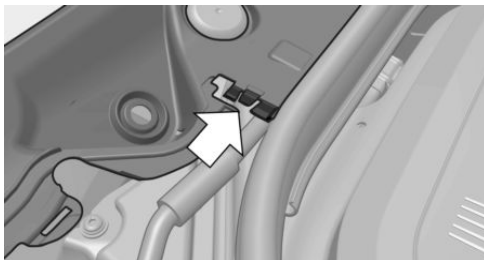

3. Press fastening downwards and tighten the three screws.

## Inside the boot

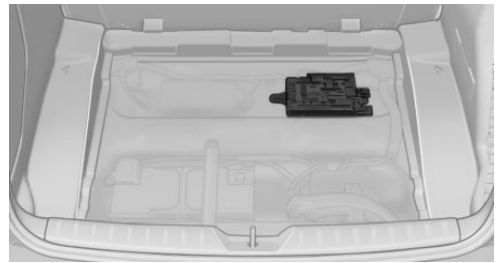

Fold up boot floor.

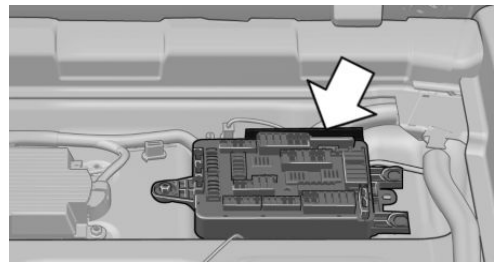

Details of the fuse assignment are on a separate leaflet.

# Help in the event of a breakdown

## Vehicle equipment

This chapter describes all standard, national and special equipment provided in the model series. Equipment not available in the vehicle is therefore also described, for example the selected special equipment or national version. This also applies to safety-relevant functions and systems. Comply with the relevant national regulations when using the corresponding functions and systems.

## Hazard warning lights

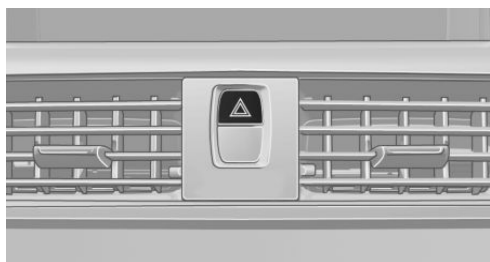

The button is located in the centre console.

## Intelligent emergency call

### Principle

This system can be used for sending an emergency call in emergency situations.

### General

Press the SOS button in an emergency only.

Even if no emergency call through BMW is possible, in some cases an emergency call may still be set up to a public emergency call number. This depends on factors such as the specific mobile telephone network and the national regulations.

For technical reasons, it might not be possible to make an emergency call in highly adverse conditions.

### Overview



SOS button in headlining

### Requirements

- ▷ SIM card integrated into the vehicle is activated.
- ▷ Radio ready state is switched on.
- ▷ Emergency call system is functional.

### Making an emergency call

1. Briefly press the cover flap to open it.
  2. Press the SOS button until the LED on the button is illuminated green.
- ▷ LED illuminated green: emergency call activated.

If a cancellation request is shown on the display, the emergency call can be cancelled.

If the situation permits, wait in the vehicle until voice contact has been established.

- ▷ LED flashes green when the connection to the emergency number has been established.

When an emergency call is sent via BMW, data is sent to the emergency call centre in order to decide what rescue measures are

required. For example, the current position of the vehicle, if this can be determined. If questions posed by the emergency call centre remain unanswered, rescue measures are automatically initiated.

- ▷ If the LED is flashing green but the emergency call centre can no longer be heard over the loudspeaker, you may still be able to be heard by the emergency call centre.

### Automatically activating emergency calls

In certain circumstances, an emergency call may be placed automatically immediately after a serious accident. An automatic emergency call is not influenced by pressing the SOS button.

### Warning triangle



The warning triangle is located inside the boot lid.

To remove, release the mounts.

### First-aid kit

#### Note

The longevity of some items is limited.

Check the use-by dates of the contents regularly and replace any items that have expired in good time.

### Storage



The first-aid kit is located on the right in a storage compartment in the boot.

### Starting assistance

#### General

If the vehicle battery is discharged, the engine can be started using two jump leads from another vehicle's battery. Use only jump leads with fully insulated terminal clamps.

#### Information



#### DANGER

Touching live components can result in an electric shock. Danger of injury or life. Do not touch any components that could be live. ◀

Do not deviate from the procedure described below, otherwise personal injury could result or both vehicles could be damaged.

#### Preparations



#### ATTENTION

Contact between the bodies of the two vehicles can result in a short circuit during starting assistance. Danger of damage to property. Make sure there is no contact between the bodies. ◀

1. Check whether the battery in the other vehicle shows 12 volts. Specifications are on the battery.
2. Switch off the engine of the donor vehicle.

3. Switch off any electrical systems in both vehicles.

### Jump-starting connections



#### WARNING

Connecting the jump leads in the wrong sequence can cause sparks. Danger of injury. Comply with the correct sequence when connecting up. ◀

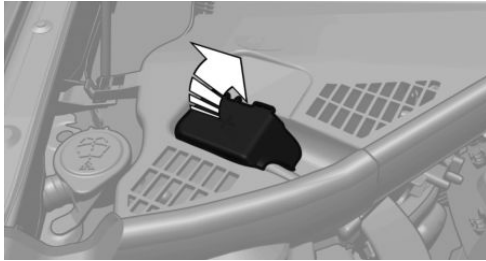

The jump-starting connection in the engine compartment serves as the positive battery terminal.

Open the cover of the starting assistance connection.

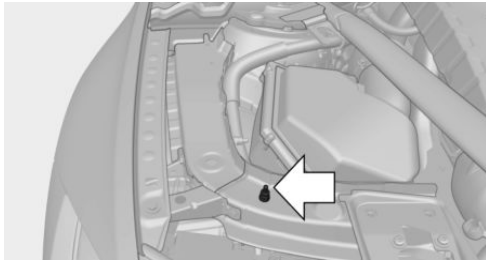

The battery negative terminal is the body earth or a special nut.

### Connecting the cables

1. Open the cover of the BMW starting assistance connection.
2. Connect a terminal clamp on the positive/+ jump lead to the positive terminal of the battery or the corresponding jump-starting connection on the donor vehicle.

3. Connect the other terminal clamp to the battery's positive terminal or to the corresponding jump-starting connection on the vehicle to be started.
4. Connect a terminal clamp on the negative/- jump lead to the negative terminal of the battery or the corresponding engine or body earth connection on the donor vehicle.
5. Connect the second terminal clamp to the negative terminal of the battery or to a ground/earth connection on the corresponding engine or body of the vehicle to be started.

### Starting the engine

Do not use the spray products sold as starting aids.

1. Start the engine of the donor vehicle and allow it to run for a few minutes at a slightly increased idle speed.
2. Start the engine of the vehicle to be started as normal.

If an initial attempt to start the engine fails, wait several minutes until the flat battery has been recharged to a slightly greater degree.

3. Allow both engines to run for a few minutes.
4. Disconnect the jump leads in the opposite order from that in which they were originally attached.

Check the battery if necessary and have it recharged.

## Tow-starting and towing

### Information



#### WARNING

Due to system limitations, there may be malfunctions of individual functions when tow-starting/towing with activated Intelligent Safety

Systems, for example approach control warning with light braking function. Danger of accidents. Switch off all Intelligent Safety Systems before tow-starting/towing. ◀

## Manual gearbox

Gearshift lever in idle position.

## Being towed

Observe the following information:

- ▶ Make sure that the ignition is switched on, otherwise low-beam headlights, rear lights, turn indicators and wipers would not be available.
- ▶ Do not tow the vehicle with the rear axle raised, otherwise the steering can turn.
- ▶ When the engine is not running, there is no power assistance and the brake servo is out of action. The steering and brakes will require extra effort to operate.
- ▶ Greater steering wheel movements are necessary.
- ▶ The towing vehicle must not be lighter than the towed vehicle, otherwise it may be unable to keep the towed vehicle reliably under control.
- ▶ Do not exceed a towing speed of on 50 km/h, 30 mph.
- ▶ Do not exceed a towing distance of 50 km, 30 miles.

## Towing truck

### With driven rear axle

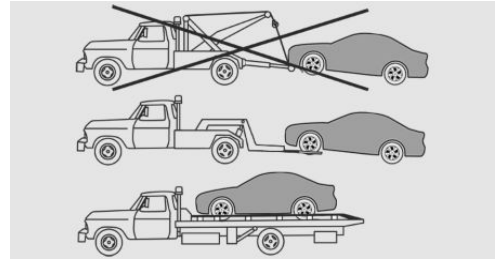

Have the vehicle transported by a towing truck with a hoisting frame, or hoisted onto a loading platform.



### ATTENTION

Raising the vehicle at the towing eye, body or suspension components can cause damage to vehicle parts. Danger of damage to property. Raise vehicle with suitable fixtures. ◀

## M double clutch transmission: transporting your vehicle

### Note

Do not attempt to have your vehicle towed. For this reason contact a Service Partner or a qualified specialist workshop in the event of a breakdown.



### ATTENTION

If the vehicle is towed with an individually lifted axle, the vehicle can be damaged. Danger of damage to property. Only have the vehicle transported on a load platform. ◀

## Towing truck

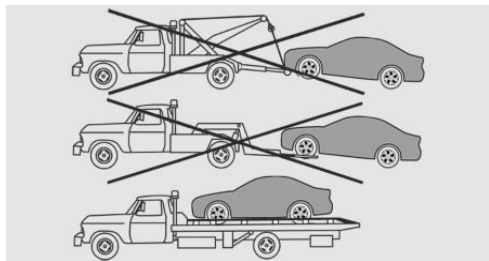

Only have the vehicle transported on a load platform.



### ATTENTION

Raising the vehicle at the towing eye, body or suspension components can cause damage to vehicle parts. Danger of damage to property. Raise vehicle with suitable fixtures. ◀

Use the towing eye screwed into the socket at the front of the vehicle for manoeuvring only.

## Towing other vehicles

### Information



### WARNING

If the gross vehicle weight of the towing vehicle is less than that of the vehicle to be towed, the towing eye can be pulled off, or the vehicle may no longer be controllable. Danger of accidents! Make sure that the gross vehicle weight of the towing vehicle is more than the weight of the vehicle to be towed. ◀



### ATTENTION

If the tow bar or the towing rope is not attached correctly, other vehicle parts can be damaged. Danger of damage to property. Attach the tow bar or towing rope to the towing eye correctly. ◀

- ▷ Switch on the hazard warning lights, depending on local regulations.
- ▷ If the vehicle's electrical system has failed, the vehicle being towed must be made

identifiable to following vehicles, for instance by placing a notice or the warning triangle in the rear window.

### Tow bar

The towing eyes of both vehicles should be on the same side.

If it is impossible to avoid attaching the tow bar at an angle, note the following:

- ▷ Tow bar clearance may be restricted when cornering.
- ▷ The tow bar will generate lateral forces if it is attached offset.

### Towing rope

Ensure that the towing rope is taut when the towing vehicle moves off.

For towing, use nylon ropes or straps, as these will help to avoid sudden tensile loads.

### Towing eye

#### General

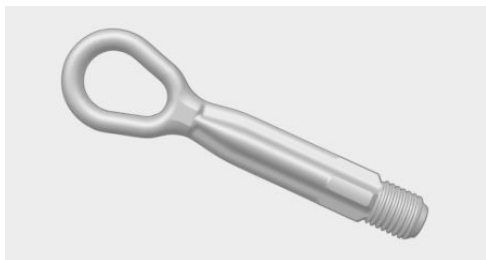

Always have the screw-on towing eye on board the vehicle.

The towing eye can be screwed into the front or rear end of the BMW.

The towing eye together with the on-board tool kit, see page 193, is located in the boot.

## Notes

### ATTENTION

If the towing eye is not used as intended, the vehicle or towing eye is damaged. Danger of damage to property. Observe the notes on using the towing eye. ◀

Using the towing eye:

- ▶ Use only the towing eye supplied with the vehicle, and make sure that it is screwed in fully and is tight.
- ▶ Only use the towing eye for towing on normal roads (in other words not off-road).
- ▶ Use the towing eye screwed into the socket at the front of the vehicle for manoeuvring only.
- ▶ Avoid lateral loads on the towing eye, for example do not raise the vehicle at the towing eye.

## Thread for towing eye

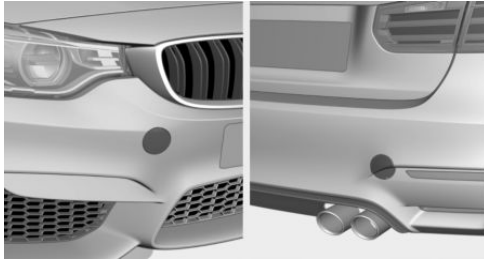

Press the marking on the front cover to press it out.

Use the screwdriver from the on-board toolkit to press out the rear cover at the opening.

## Tow-starting

### M double clutch transmission

Do not attempt to tow-start or push-start the vehicle.

Due to the M double clutch transmission it is not possible to start the engine by towing.

Have the cause of the starting difficulties rectified.

### Manual gearbox

If possible, do not tow-start the vehicle but start the engine using starting assistance, see page 203. Only tow-start when the engine is cold if your vehicle has a catalytic converter.

1. Switching on hazard warning lights, please observe country-specific regulations.
2. Ignition, see page 65, on.
3. Insert 3rd gear.
4. Tow-start with the clutch depressed and release the clutch slowly. Depress the clutch again immediately after the engine starts.
5. Stop in a suitable location, remove the tow bar or towing rope and switch off the hazard warning lights.
6. Have the vehicle checked.

# General care

## Vehicle equipment

This chapter describes all standard, national and special equipment provided in the model series. Equipment not available in the vehicle is therefore also described, for example the selected special equipment or national version. This also applies to safety-relevant functions and systems. Comply with the relevant national regulations when using the corresponding functions and systems.

## Washing the vehicle

### General

Regularly remove foreign bodies, for example, leaves, with the bonnet opened in the area beneath with windscreen.

Especially in winter, wash the car more frequently. Very high levels of dirt and spreading salt can cause damage to the car.

### Steam-jet cleaners and high-pressure cleaners

#### Notes



#### ATTENTION

When cleaning with high-pressure cleaners, excessive pressure or excessive temperatures can damage various components. Danger of damage to property. Ensure a sufficient distance and do not spray for an extended period of time. Comply with the instructions for the high-pressure cleaner. ◀

### Distances and temperature

- ▷ Maximum temperature: 60 °C/140 °F.
- ▷ Minimum distance to sensors, cameras, seals: 30 cm, approx. 12 in.

- ▷ Minimum distance to the Glass Roof: 80 cm, approx. 31.5 in.

### Automatic car washes.

#### Notes



#### ATTENTION

Water can penetrate in the window area due to high pressure washers. Danger of damage to property. Avoid high pressure washers. ◀

- ▷ Textile car washes or systems using soft brushes are preferable, to avoid damage to the paintwork.
- ▷ Make sure the wheels and tyres are not damaged by the conveying mechanism.
- ▷ Fold in the exterior mirrors, as they could otherwise sustain damage due to the vehicle's width.
- ▷ Deactivate the rain sensor, see page 72, to avoid unintentional operation of the wipers.
- ▷ In some instances, depending on the interior movement detector of the alarm system, a false alarm may be triggered. Observe the notes on avoiding false alarm, see page 43.



#### ATTENTION

Excessively high guide rails in car washes can damage parts of the body. Danger of damage to property. Avoid washing bays or car washes with guide rails more than 10 cm, approximately 4 in high. ◀

### Entering a car wash

Follow the below steps so that the vehicle can be driven into a vehicle wash:

Manual gearbox:

1. Drive into the car wash.
2. Engage idle position.
3. Stop the engine.
4. Switch on ignition.

M double clutch transmission:

1. Drive into the car wash.
2. Engage selector lever position N.
3. Stop the engine.

In this way the ignition remains switched on and a Check Control message is displayed.

It is not possible to lock the vehicle from the outside in selector lever position N. If an attempt is made to lock the vehicle, a signal sounds.

When starting engine with manual gearbox:

1. Press clutch pedal.
2. Press the start/stop button.

When starting engine with M double clutch transmission:

1. Press the brake.
2. Press the start/stop button.

Pressing the start/stop button or depressing the brake switches off the ignition.

## Transmission position

Transmission position P is automatically engaged:

- With the ignition switched off.
- After approximately 15 minutes.

## Headlights

- Do not rub them when dry or use abrasive or corrosive cleaning agents.
- Soak impurities such as insects with shampoo and wash off with water.
- Remove ice with a de-icer spray; do not use an ice scraper.

## After washing the car

After washing the car, drive it briefly and apply the brakes to dry them out; this is necessary to prevent reduced braking action, and also to avoid corrosion of the brake discs.

Completely remove residues on the wind-screens to avoid affecting visibility due to smearing, and to reduce wiping noise and wiper blade wear.

## Car care

### Care products

The manufacturer of your vehicle recommends the use of BMW care and cleaning products, as they are tested by BMW and categorised as suitable for the use on the vehicle.



### WARNING

Cleaning agents can contain hazardous substances or constitute a health risk. Danger of injury. When cleaning the interior, open the doors or windows. Use only products that are intended for cleaning the vehicle's interior. Observe the notes on the pack. ◀

## Vehicle paintwork

Regular care promotes driving safety and preserves your vehicle's value. Environmental effects in areas with higher air pollution or natural contaminations, for example tree resin or leaf dust, may have an effect on the vehicle paintwork. Base the frequency and extent of vehicle care on such factors.

Remove corrosive substances, such as run-off fuel, oil, grease or bird droppings immediately to avoid changes to the paint or discolourations.

Only use suitable cleaning and care products for matt paintwork. Suitable matt paintwork care products are available from a Service Partner or a qualified specialist workshop.

## Leather care

Remove dust from the leather at regular intervals with a cloth or vacuum cleaner.

Dust and road dirt will otherwise become worked into pores and folds, causing considerable abrasion and causing the leather surface to become prematurely brittle.

In order to protect against discolouration, for example from clothing, clean the leather approximately every two months.

Clean light-coloured leather more frequently as it has the tendency to soil faster.

Use leather cleaner, otherwise dirt and grease will attack the protective coating of the leather.

Suitable care products are available from a Service Partner or a qualified specialist workshop.

## Care of upholstery fabrics

Clean regularly with a vacuum cleaner.

In the event of heavy soiling, for example stains caused by drinks, use a soft sponge or a lint-free microfibre cloth with suitable interior cleaning agents.

Clean upholstery materials over a large area up to the seams. Avoid strong rubbing.



### ATTENTION

Open Velcro fasteners on articles of clothing can damage the seat covers. Danger of damage to property. Make sure that any Velcro fasteners on your clothing are closed. ◀

## Care of special parts

### Light alloy wheels

Only when cleaning on the vehicle use neutral rim cleaner with a pH value of between 5 and 9. Do not use any rough cleaner or steam cleaner above 60 °C/140 °F. Observe the manufacturer's information.

Corrosive, acidic or alkaline cleaners may destroy the protective layer of neighbouring parts, such as brake discs, for example.

## Chrome surfaces

Carefully clean parts such as the radiator grille and door handles with plenty of water to which a shampoo may be added, particularly if exposed to road salt.

## Rubber parts

The surfaces of rubber parts can be contaminated or lose their shine due to environmental influences. Only use water and suitable care products for cleaning. The manufacturer of your vehicle recommends genuine BMW care products.

Treat particularly stressed rubber parts at regular intervals with rubber care products. Do not use any silicone-based care products for treating rubber seals, otherwise these could be damaged and become a source of noise.

## Fine wood parts

Clean fine wood trims and fine wood parts with a damp cloth only. Then dry them with a soft cloth.

## Plastic parts

These include:

- ▶ Imitation leather surfaces.
- ▶ Roof lining.
- ▶ Light covers.
- ▶ Glass cover of instrument cluster.
- ▶ Parts sprayed matt black.
- ▶ Painted parts in the interior.

Use a microfibre cloth to clean.

Slightly moisten the cloth with water.

Do not soak the roof lining.

**ATTENTION**

Cleaning agents containing alcohol or solvents, such as nitro thinners, cold cleansers, fuel or similar can damage plastic parts. Danger of damage to property. Use a microfibre cloth to clean. Slightly moisten the cloth with water. ◀

**Seat belts**

Dirt on the seat belts can interfere with the action of the reel and represent a safety hazard.

**WARNING**

Chemical cleaners can cause irreparable damage to the fabric of the seat belts. Lack of protective effect of the seat belts. Danger of injury or life. Only use a mild soap and water solution for cleaning the seat belts. ◀

Clean only with a mild soap solution while still fitted to the vehicle.

Never allow seat belts to retract unless they are dry.

**Carpets and foot mats****WARNING**

Objects in the driver's footwell can restrict the pedal travel, or block a pedal that has been pressed. Danger of accidents. Stow items in the vehicle so that they are secure and cannot get into the driver's footwell. Only use floor mats that have been categorised as appropriate for the vehicle and that can be fastened accordingly. Do not use any loose floor mats, and do not place several floor mats on top of one another. Make sure that there is sufficient space for the pedals. Ensure that the floor mats are securely reattached after having been removed, for example for cleaning. ◀

Floor mats can be removed from the vehicle to enable the interior to be cleaned more thoroughly.

In the event of heavy soiling, clean floor carpets using a microfibre cloth and water or tex-

tile cleaner. In doing so, rub back and forth in the direction of travel, otherwise the carpet can become tangled.

**Sensors/lenses of the camera**

Clean sensors or lenses of the camera using a cloth moistened with a small amount of a glass detergent.

**Displays/screens/protective sleeve of the Head-Up Displays****ATTENTION**

Chemical cleaners, moisture or fluids of all kinds can damage the surface of displays and screens. Danger of damage to property. Use a clean, anti-static microfibre cloth to clean. ◀

**ATTENTION**

The surfaces of displays can be damaged due to improper cleaning. Danger of damage to property. Avoid applying excessive pressure and do not use abrasive materials. ◀

Use a clean, anti-static microfibre cloth to clean.

Clean the protective sleeve of the Head-Up Display with a microfibre cloth and commercially available dishwashing liquid.

**Laying up out of use**

When the vehicle is laid up for longer than three months, special measures are to be taken. Further information is available from a Service Partner or a qualified specialist workshop.



## Reference

The section contains the technical data and the alphabetical index that will lead you to the desired information in the quickest manner possible.

# Technical data

## Vehicle equipment

This chapter describes all standard, national and special equipment provided in the model series. Equipment not available in the vehicle is therefore also described, for example the se-

lected special equipment or national version. This also applies to safety-relevant functions and systems. Comply with the relevant national regulations when using the corresponding functions and systems.

## Note

The technical data and specifications in the Owner's Handbook are indications. The vehicle-specific data can deviate from this, for example, due to selected special equipment, national version or country-specific measurement method. Detailed values can be

found in the permit documents, on information stickers on the vehicle or can be requested from a Service Partner or a qualified specialist workshop.

The information in the vehicle documents always has priority.

## Dimensions

The dimensions can vary depending on the model version, equipment or country-specific measurement method.

The heights specified do not take into account add-on parts such as a roof aerial, roof railing

or spoiler. The heights can deviate, for example, due to the selected special equipment, tyres, loads and chassis design.

### BMW M4 Coupé

Width with mirrors	mm	2014
Width without mirrors	mm	1870
Height	mm	1383
Length	mm	4671
Wheelbase	mm	2812
Smallest turning circle dia.	m/ft	12.2 (40.1)

## Weights

### BMW M4 Coupé

Kerb weight, ready for road, with 75 kg, 165 lb, load, tank 90 % full, no optional extras

Manual gearbox	kg (lb)	1572 (3465)
----------------	---------	-------------

M double clutch transmission	kg (lb)	1612 (3553)
------------------------------	---------	-------------

Permitted gross weight	kg (lb)	2040 (4497)
------------------------	---------	-------------

#### Load

Manual gearbox	kg (lb)	543 (1197)
----------------	---------	------------

M double clutch transmission	kg (lb)	503 (1108)
------------------------------	---------	------------

Front axle load limit	kg (lb)	970 (2138)
-----------------------	---------	------------

Rear axle load limit	kg (lb)	1130 (2491)
----------------------	---------	-------------

Roof load	kg (lb)	75 (165)
-----------	---------	----------

Boot capacity	litres (cu ft)	445 (15.7)
---------------	----------------	------------

## Filling capacities

	Litres/Imp. Gall.	Note
Fuel tank, approximately.	60/13.2	Fuel grade, see page <a href="#">174</a>

# Appendix

Here is where any updates to the Owner's Handbook for the vehicle are listed.



# Everything from A to Z

## Index

### A

- ABS, anti-lock braking system [123](#)
- Acceleration assistant, see Launch Control [77](#)
- Accessories and parts [8](#)
- Activation, airbags [106](#)
- Active M differential [126](#)
- Active Protection [120](#)
- Adaptive brake light, see Dynamic brake lights [120](#)
- Adaptive Headlights [100](#)
- Adaptive M chassis [126](#)
- Additives, oil [187](#)
- Adjust headlights [102](#)
- After washing the car [209](#)
- Age of tyres [176](#)
- Airbags [104](#)
- Airbags, indicator/warning lamp [105](#)
- Airbag switch, see Key switch for front passenger airbags [106](#)
- Air conditioning [144](#)
- Air distribution, manual [146](#)
- Air flow, automatic air conditioning [146](#)
- Air outlets, see Ventilation [147](#)
- Air pressure, tyres [175](#)
- Alarm, false [43](#)
- Alarm system [42](#)
- All-season tyres, see Winter tyres [177](#)
- Alternative oil grades [187](#)
- Ambient lighting [103](#)
- Anti-freeze protection, washer fluid [73](#)
- Anti-lock braking system, ABS [123](#)
- Anti-theft alarm system, see Alarm system [42](#)
- Anti-theft system, wheel studs [199](#)
- Anti-trap mechanism, glass Roof [46](#)
- Anti-trap mechanism, windows [44](#)
- Approved engine oils, see Suitable engine oil grades [187](#)
- Aquaplaning [163](#)
- Around the centre console [14](#)
- Around the headlining [15](#)
- Around the steering wheel [12](#)
- Arrival time [92](#)
- Ashtray [149](#)
- Attentiveness assistant [121](#)
- AUC, automatic air recirculation control [146](#)
- AUTO intensity [145](#)
- Automatic air conditioning [144](#)
- Automatic air recirculation control, AUC [146](#)
- Automatic anti-glare control, see High-beam assistance [100](#)
- Automatic driving lights control [99](#)
- Automatic locking [42](#)
- Automatic parking function [56](#)
- AUTO program, automatic air conditioning [145](#)
- AUTO program, intensity [145](#)
- Auto Start Stop function [67](#)
- Average fuel consumption [91](#)
- Average speed [91](#)
- Axle load limit [215](#)
- Axle loads, weight [215](#)

### B

- Backrest contour, see Lumbar support [50](#)
- Backrest width [50](#)
- Bar for tow-starting/towing [206](#)
- Battery, vehicle [199](#)
- Being towed, see Tow-starting/towing [204](#)
- Belt holder [54](#)
- Belts, seat belts [52](#)
- Black ice, see Outside temperature warning [84](#)
- Blower, see Air flow [146](#)
- BMW Driver's Guide App [6](#)
- BMW homepage [6](#)
- BMW internet site [6](#)
- BMW Maintenance System [191](#)
- BMW M Technology [160](#)
- BMW Services [6](#)
- Bonnet [183](#)
- Boot lid closing [38](#)
- Boot lid, contactless opening [40](#)
- Boot lid, emergency release [39](#)
- Boot lid via remote control [36](#)
- Boot, storage space [156](#)
- Bottle holder, see Cupholder [155](#)
- Brake assist [123](#)
- Brake lights, adaptive [120](#)
- Brake lights, dynamic [120](#)
- Braking, information [163](#)
- Braking safely [163](#)
- Breakdown Assist [202](#)

Breakdown, wheel  
  change [199](#)  
Brightness of the Control Display [94](#)  
Bulb change, rear [196](#)  
Bulb change, xenon headlight [194](#)  
Buttons on the steering wheel [12](#)  
Button, start/stop [65](#)

## C

Camera, rear-view camera [134](#)  
Camera, Side View [136](#)  
Camera, Top View [138](#)  
Carbon ceramic brakes  
  M [160](#)  
Car care [209](#)  
Care, displays [211](#)  
Care products [209](#)  
Care, vehicle [209](#)  
Car jack [199](#)  
Car key, see Remote control [32](#)  
Carpet, care [211](#)  
Carrying children safely [58](#)  
Car washes [208](#)  
Catalytic converter, see Hot exhaust system [163](#)  
CBS, Condition Based Service [191](#)  
Central key, see Remote control [32](#)  
Central locking system [38](#)  
Central screen, see Control Display [16](#)  
Centre armrest [154](#)  
Centre console [14](#)  
Ceramic brakes [160](#)  
Changes, technical, see Your own safety [7](#)  
Changing bulb, rear [196](#)  
Charcoal canister [146](#)  
Chassis, electronic [126](#)  
Chassis number, see Vehicle identification number [9](#)  
Check control [80](#)  
Checking the oil level electronically [185](#)  
Child's seats [58](#)  
Children, carrying [58](#)  
Child restraints [58](#)  
Child seat classes, ISOFIX [61](#)  
Child seat mounting [59](#)  
Child seat mountings, ISOFIX [61](#)  
Chrome parts, care [210](#)  
Cigarette lighter [149](#)  
Cleaning displays [211](#)  
Clock [85](#)  
Closing/opening using door lock [37](#)  
Closing/opening with remote control [35](#)  
Coat hooks [155](#)  
Cockpit [12](#)  
Comfort Access [39](#)  
Comfort closing with the remote control [36](#)  
Comfort opening with the remote control [36](#)  
Compound brakes [160](#)  
Compressor [178](#)  
Computer, see on-board computer [90](#)  
Condensate under the vehicle [165](#)  
Condensation on windows [146](#)  
Condition Based Service, CBS [191](#)  
Confirmation signals [42](#)  
ConnectedDrive [6](#)  
ConnectedDrive services [6](#)  
Connecting electrical appliances [150](#)  
Contactless opening of boot lid [40](#)  
Control Display [16](#)  
Control display, settings [93](#)

Controller [17](#)  
Control systems, driving stability [123](#)  
Coolant [189](#)  
Coolant temperature [84](#)  
Cooling effect, maximum [145](#)  
Cooling function [145](#)  
Cooling system [189](#)  
Cornering light [100](#)  
Corrosion of brake discs [164](#)  
Courtesy light when unlocking [35](#)  
Courtesy light with the vehicle locked [36](#)  
Cruise Control [129](#)  
Cupholder [155](#)  
Current fuel consumption [86](#)

## D

Damage, tyres [176](#)  
Damper control [126](#)  
Data, technical [214](#)  
Date [85](#)  
Daytime driving lights [100](#)  
Deactivation, airbags [106](#)  
Defrosting, see Defrosting windows [146](#)  
Defrosting windows [146](#)  
Defrost, see Defrosting windows [146](#)  
Deleting personal data [23](#)  
Differential lock [126](#)  
Digital clock [85](#)  
Digital speed [85](#)  
Digital speedometer [85](#)  
Dimensions [214](#)  
Dimmable exterior mirrors [56](#)  
Dimming rear-view mirror [56](#)  
Dipping headlights, see High-beam assistance [100](#)  
Display in windscreen [94](#)  
Display lighting, see Instrument lighting [102](#)  
Displays, cleaning [211](#)

Displays, electronic, instrument cluster [79](#)  
Disposal, coolant [190](#)  
Disposal, vehicle battery [200](#)  
Distance to destination [91](#)  
Distance warning, see PDC [131](#)  
Door key, see Remote control [32](#)  
Door lock [37](#)  
Double clutch transmission [74](#)  
Downhill gradients [164](#)  
Drinks holder, see Cupholder [155](#)  
Drivelogic [76](#)  
Drive Mode [75](#)  
Drive-off assistant [127](#)  
Drive programs, see Drivelogic [76](#)  
Driving Assistant, see Intelligent Safety [110](#)  
Driving dynamics, system states [86](#)  
Driving dynamic systems [86](#)  
Driving hints [163](#)  
Driving information, general [163](#)  
Driving information, running in [162](#)  
Driving into a car wash [208](#)  
Driving lane lines, rear-view camera [135](#)  
Driving lights control, automatic [99](#)  
Driving on racing tracks [161](#)  
Driving stability control systems [123](#)  
Drying air, see Cooling function [145](#)  
DSC Dynamic Stability Control [124](#)  
Dynamic brake lights [120](#)  
Dynamic Stability Control, DSC [124](#)

## E

EfficientDynamics [86](#)  
EfficientDynamics display [86](#)  
EfficientDynamics menu [86](#)  
Electrical Glass Roof [45](#)  
Electrical power windows [43](#)  
Electric steering wheel lock [57](#)  
Electronic displays, instrument cluster [79](#)  
Electronic oil measurement [185](#)  
Electronic Stability Program, ESP, see DSC [124](#)  
Emergency call [202](#)  
Emergency release, boot lid [39](#)  
Emergency release, fuel filler flap [172](#)  
Emergency start function, engine start [33](#)  
Energy Control [86](#)  
Energy recuperation [86](#)  
Engine, automatic shut-off [67](#)  
Engine, automatic start-stop function [67](#)  
Engine compartment [182](#)  
Engine coolant [189](#)  
Engine Dynamics Control [78](#)  
Engine oil [185](#)  
Engine oil additives [187](#)  
Engine oil change [187](#)  
Engine oil filler neck [186](#)  
Engine oil grades, alternative [187](#)  
Engine oil grades, suitable [187](#)  
Engine oil level, checking electronically [185](#)  
Engine oil temperature [84](#)  
Engine start [66](#)  
Engine start with malfunction [33](#)  
Engine temperature [84](#)

Entering letters and digits [23](#)  
ESP, Electronic Stability Program, see DSC [124](#)  
Exhaust system [163](#)  
Expanding the boot [151](#)  
Extended BMW Online services [6](#)  
Exterior mirror, automatically dimming [56](#)  
Exterior mirrors [55](#)  
External starting [203](#)  
Eye for towing, see Towing eye [206](#)  
Eyes for securing load [166](#)

## F

Failure message, see Check control [80](#)  
False alarm [43](#)  
Fastening seat belts, see Seat belts [52](#)  
Fault displays, see Check control [80](#)  
Favourites buttons, iDrive [22](#)  
Filler neck for engine oil [186](#)  
Fine wood, care [210](#)  
First-aid kit [203](#)  
Flat tyre, warning lamp [108, 109](#)  
Flooding [163](#)  
Floor carpet, care [211](#)  
Fold-out position, windscreen wiper [72](#)  
Foot brake [163](#)  
Foot mats, care [211](#)  
Front airbags [104](#)  
Front-end collision warning with city braking function [111](#)  
Front head restraints [54](#)  
Front lights [194](#)  
Front neck supports, see Head restraints [54](#)  
Front passenger airbags, deactivating/activating [106](#)

Front passenger airbags, light [106](#)  
Fuel [174](#)  
Fuel consumption, see Average fuel consumption [91](#)  
Fuel filler flap [172](#)  
Fuel gauge [84](#)  
Fuel quality [174](#)  
Fuel recommendation [174](#)  
Fuel tank cap [172](#)  
Fuel, tank capacity [215](#)  
Fuse [200](#)

## G

Gearbox, manual gearbox [73](#)  
Gear change [76](#)  
Gearshift, manual gearbox [73](#)  
General driving information [163](#)  
Glare protection [149](#)  
Glass Roof, electric [45](#)  
Glove box [153](#)  
Ground clearance [165](#)

## H

Handbrake, see Parking brake [69](#)  
Hazard warning and indicator lights, see Check control [80](#)  
Hazard warning lights [202](#)  
Head airbags [104](#)  
Headlight cleaning system, see Wiper system [71](#)  
Headlight courtesy delay feature [99](#)  
Headlight flasher [70](#)  
Headlight lens [194](#)  
Headlights [194](#)  
Headlights, care [209](#)  
Headlining [15](#)  
Head restraints [48](#)  
Head-Up Display [94](#)  
Head-Up Display, care [211](#)  
Head-Up Display, M View [95](#)

Head-Up Display, standard view [95](#)  
Heated rear window [146](#)  
Heavy transported load, stowing transported load [166](#)  
Height, vehicle [214](#)  
Help in driving off [127](#)  
High-beam assistance [100](#)  
High-beam headlights [70](#)  
High performance engine [160](#)  
Hill Start Assist, see Drive-off assistant [127](#)  
Homepage [6](#)  
Horn [12](#)  
Hot exhaust system [163](#)  
HUD Head-Up Display [94](#)

## I

IBA Integrated Owner's Handbook in vehicle [28](#)  
Ice warning, see Outside temperature warning [84](#)  
Identification number, see Vehicle identification number [9](#)  
iDrive [16](#)  
Ignition key, see Remote control [32](#)  
Ignition off [65](#)  
Ignition on [65](#)  
Important considerations [58](#)  
Important information regarding the engine compartment [182](#)  
Independent ventilation [147](#)  
Indicator and hazard warning lights, see Check control [80](#)  
Indicator lights, see Check control [80](#)  
Indicators, see Turn indicators [70](#)  
Individual air distribution [146](#)  
Individual settings, see M Drive [123](#)

Individual settings, see Personal Profile [33](#)  
Inflation pressure, tyres [175](#)  
Inflation pressure warning RPA, tyres [109](#)  
Info Display, see on-board computer [90](#)  
Information on no passing [88](#)  
Information on speed limit [88](#)  
Initialise, Tyre Pressure Monitor TPM [107](#)  
Initialising, runflat indicator, RPA [109](#)  
Instrument cluster [79](#)  
Instrument cluster, electronic displays [79](#)  
Instrument cluster switch, see Turn indicators [70](#)  
Instrument cluster switch, see Wiper system [71](#)  
Instrument lighting [102](#)  
Integrated key [32](#)  
Integrated Owner's Handbook in vehicle [28](#)  
Intelligent emergency call [202](#)  
Intelligent Safety [110](#)  
Intensity, AUTO Automatic program [145](#)  
Interior light [102](#)  
Interior light when unlocking [35](#)  
Interior light with the vehicle locked [36](#)  
Interior movement detector [43](#)  
Intermittent mode [71](#)  
Internet site [6](#)  
Interval display, service requirement [87](#)  
ISOFIX child seat mountings [61](#)

## J

Jack mounting points [199](#)

Journey computer [92](#)  
Jump-starting connection, starting assistance [204](#)  
Jump starting, see starting assistance [203](#)

## K

Key/remote control [32](#)  
Keyless Go, see Comfort Access [39](#)  
Key memory, see Personal Profile [33](#)  
Key switch for front passenger airbags [106](#)

## L

Labelling of recommended tyres [177](#)  
Lane boundary, warning [115](#)  
Lane change warning [117](#)  
Lane departure warning [115](#)  
Language, on the control display [94](#)  
Lashing eyes, securing load [166](#)  
Lashing straps, securing load [166](#)  
Launch Control [77](#)  
Laying up out of use [211](#)  
Laying up, vehicle [211](#)  
Leather, care [210](#)  
LED light, replacing the bulbs [195](#)  
LEDs, light-emitting diodes [194](#)  
Left-hand traffic, light setting [102](#)  
Lenses of camera, care [211](#)  
Light alloy wheels, care [210](#)  
Light-emitting diodes, LEDs [194](#)  
Lighter [149](#)  
Lighting [98](#)

Light in the exterior mirror, see Lane Change Warning [117](#)  
Lights [98](#)  
Lights and light bulbs [193](#)  
Light switch [98](#)  
LIM button, see Manual Speed Limiter [119](#)  
Load [166](#)  
Loads [166](#)  
Lock, door [37](#)  
Locking/unlocking using door lock [37](#)  
Locking/unlocking with remote control [35](#)  
Locking, automatic [42](#)  
Locking settings [41](#)  
Locking via the boot lid [38](#)  
Lock, wheel studs [199](#)  
Low-beam headlights [98](#)  
Lower back support [50](#)  
Low Speed Assistant [74](#)  
Luggage rack, see Roof rack [167](#)  
Lumbar support [50](#)

## M

Maintenance [191](#)  
Maintenance requirement [191](#)  
Maintenance, service requirement [87](#)  
Maintenance System BMW [191](#)  
Malfunction displays, see Check control [80](#)  
Manual air distribution [146](#)  
Manual air flow [146](#)  
Manual gearbox [73](#)  
Manual operation, door lock [37](#)  
Manual operation, exterior mirrors [56](#)  
Manual operation, fuel filler flap [172](#)  
Manual operation, Park Distance Control, PDC [132](#)  
Manual operation, rear-view camera [134](#)  
Manual operation, Side View [137](#)  
Manual operation, Top View [138](#)  
Manual Speed Limiter [119](#)  
Maximum cooling effect [145](#)  
Maximum speed range [165](#)  
Maximum speed, winter tyres [177](#)  
M Carbon ceramic brakes [160](#)  
M compound brakes [160](#)  
M differential, active [126](#)  
MDM, M Dynamic Mode [125](#)  
M double clutch transmission [74](#)  
M Drive [123](#)  
M Driver's Package, driving instructions [165](#)  
M Dynamic Mode MDM [125](#)  
Memory, seat, mirror [54](#)  
M Engine Dynamics Control [78](#)  
Menu in the instrument cluster [90](#)  
Menus, see iDrive operating principle [18](#)  
Message of a flat tyre [108](#), [109](#)  
Messages, see Check control [80](#)  
Microfilter [146](#)  
Minimum tread depth, tyres [176](#)  
Mirror, memory [54](#)  
Mirrors [55](#)  
Mobile communication equipment [163](#)  
Mobility system [178](#)  
Moisture in the headlight [194](#)  
Monitor, see Control Display [16](#)

Mounting child restraints [59](#)  
M Technology [160](#)  
Multifunction steering wheel,  
  buttons [12](#)  
Multimedia [6](#)  
M View, Head-Up Display [95](#)

## N

Navigation [6](#)  
Neutral cleaner, see rim  
  cleaner [210](#)  
New wheels and tyres [177](#)  
No Passing Information [88](#)  
Notes [6](#)  
Nylon ropes for tow-starting/  
  towing [206](#)

## O

OBD, see on-board diagnosis,  
  OBD [192](#)  
Obstacle marking, rear-view  
  camera [135](#)  
Octane number, see Petrol  
  grade [174](#)  
Odometer [84](#)  
Office [6](#)  
Oil [185](#)  
Oil additives [187](#)  
Oil change [187](#)  
Oil change interval, service  
  requirement [87](#)  
Oil filler neck [186](#)  
Oil grades, alternative [187](#)  
Oil grades, suitable [187](#)  
Old battery, disposing [200](#)  
On-board computer [90](#)  
On-board diagnosis,  
  OBD [192](#)  
On-board monitor, see Con-  
  trol Display [16](#)  
On-board toolkit [193](#)  
Opening/closing using door  
  lock [37](#)  
Opening and closing [32](#)

Opening and closing, without  
  remote control [37](#)  
Opening and closing with re-  
  mote control [35](#)  
Operating menus, iDrive [16](#)  
Operating principle, iDrive [16](#)  
Outside air, see AUC [146](#)  
Outside temperature dis-  
  play [84](#)  
Outside temperature warn-  
  ing [84](#)  
Overheating of the engine,  
  see Coolant temperature [84](#)

## P

Paintwork, vehicle [209](#)  
Park assistant [139](#)  
Park Distance Control  
  PDC [131](#)  
Parked vehicle, conden-  
  sate [165](#)  
Parking aid, see PDC [131](#)  
Parking assistant [139](#)  
Parking brake [69](#)  
Parking lights [99](#)  
Part replacement [193](#)  
Parts and accessories [8](#)  
Passenger's mirror, tilting  
  down [56](#)  
PDC Park Distance Con-  
  trol [131](#)  
Personal data, delete [23](#)  
Personal Profile [33](#)  
Personal profile, export pro-  
  file [34](#)  
Personal profile, import pro-  
  file [35](#)  
Person warning with city  
  braking function [113](#)  
Petrol [174](#)  
Petrol grade [174](#)  
Place for children [58](#)  
Plasters, see First-aid kit [203](#)  
Plastic, care [210](#)  
Pockets in the doors [154](#)

Power failure [200](#)  
Power windows [43](#)  
Pressure check, tyres [107](#)  
Pressure, tyres [175](#)  
Pressure warning RPA,  
  tyres [109](#)  
Preventing Auto Start  
  Stop [69](#)  
Profiles, Personal Profile [33](#)  
Protection function, glass  
  Roof [46](#)  
Protection function, win-  
  dows [44](#)  
Puncture, runflat indicator  
  RPA [109](#)

## R

Radio [6](#)  
Radio-control key, see Re-  
  mote control [32](#)  
Radio ready state [65](#)  
Radio signals [163](#)  
Rain sensor [71](#)  
Range [85](#)  
Rear backrests, folding, see  
  Through-loading sys-  
  tem [151](#)  
Rear fog lights [102](#)  
Rear lights [196](#)  
Rear-view camera [133](#)  
Rear-view mirror, automatic-  
  dim [56](#)  
Recirculated-air mode [146](#)  
Recirculating air filter [146](#)  
Recirculation, see Recircula-  
  ted-air mode [146](#)  
Recommended tyre  
  makes [177](#)  
Recycling [192](#)  
Refuelling [172](#)  
Remaining distance [85](#)  
Remedying flat tyres [178](#)  
Remote control/key [32](#)  
Remote control, malfunc-  
  tion [37](#)

- Replacement fuse [200](#)  
Replacement of parts [193](#)  
Replacement of wheels/  
tyres [177](#)  
Replacing bulbs [193](#)  
Replacing bulbs, front [194](#)  
Replacing bulbs, LED head-  
lights [195](#)  
Replacing parts [193](#)  
Replacing the battery, vehicle  
battery [199](#)  
Replacing the battery, vehicle  
remote control [33](#)  
Replacing wiper blades [193](#)  
RES button, see Cruise Con-  
trol [129](#)  
Reserve warning, see  
Range [85](#)  
Reset, Tyre Pressure Monitor  
TPM [107](#)  
Restraint systems for chil-  
dren [58](#)  
Retreaded tyres [177](#)  
Reuse [192](#)  
Reversing light [196](#)  
Revolution counter [84](#)  
Right-hand traffic, light set-  
ting [102](#)  
Rim cleaner [210](#)  
Roller sunblinds [45](#)  
RON petrol grade [174](#)  
Roof load [215](#)  
Roof rack [167](#)  
Rope for tow-starting/  
towing [206](#)  
RPA runflat indicator [109](#)  
Rubber parts, care [210](#)  
Runflat indicator RPA [109](#)  
Running in [162](#)  
Running in brake discs [162](#)  
Running in brake pads [162](#)
- S**
- Safe seated position [48](#)  
Safety package, see Active  
Protection [120](#)  
Safety systems, airbags [104](#)  
Saving fuel [168](#)  
Saving settings for seat, mir-  
ror [54](#)  
Screen, see Control Dis-  
play [16](#)  
Screwdriver, see On-board  
toolkit [193](#)  
Screw thread, see Thread for  
towing eye [207](#)  
Sealing compound [178](#)  
Seat and mirror memory [54](#)  
Seat belt reminder for driver's  
and front passenger's  
seat [53](#)  
Seat belt reminder for rear  
seats [53](#)  
Seat belts [52](#)  
Seat belts, care [211](#)  
Seat heating, front [50](#)  
Seats [48](#)  
Securing load [166](#)  
Selection list in the instru-  
ment cluster [90](#)  
Selector lever [74](#)  
Selector lever position [74](#)  
Sensors, care [211](#)  
Sequential mode [75](#)  
Service history [88](#)  
Service requirement, dis-  
play [87](#)  
Service requirements, Condi-  
tion Based Service  
CBS [191](#)  
Services, ConnectedDrive [6](#)  
Servotronic [127](#)  
Settings, locking/unlock-  
ing [41](#)  
Settings, M Drive [123](#)  
Settings on the control dis-  
play [93](#)  
Settings, seats/head re-  
straints [48](#)  
Shift Lights [96](#)  
Shift point indicator [88](#)  
Side airbags [104](#)  
Side lights [98](#)  
Side View [136](#)  
Signals on unlocking [42](#)  
Sliding/tilting roof [45](#)  
Smallest turning circle [214](#)  
Snow chains [181](#)  
Socket [150](#)  
Socket in rear passenger  
compartment [150](#)  
Socket, on-board diagnosis,  
OBD [192](#)  
SOS button [202](#)  
Sound [6](#)  
Spanner, see On-board tool-  
kit [193](#)  
Spare fuse [200](#)  
Special equipment, standard  
equipment [7](#)  
Special ID, remote control [33](#)  
Specified engine oil  
grades [187](#)  
Speed, displaying maxi-  
mum [88](#)  
Speed Limit Device, see Man-  
ual Speed Limiter [119](#)  
Speed limiter, manual [119](#)  
Speed Limit Information [88](#)  
Speed Limit Information, on-  
board computer [92](#)  
Speed limit, see Manual  
Speed Limiter [119](#)  
Speed warning [92](#)  
Split-screen [22](#)  
Split-screen view, split-  
screen [22](#)  
Sport displays, torque dis-  
play, power display [92](#)  
Stability control systems [123](#)  
Standard view, Head-Up Dis-  
play [95](#)  
Start/stop button [65](#)  
Start function with malfunc-  
tion [33](#)  
Starting assistance [203](#)

Starting assistance, see  
DSC 124

Starting, see Engine start 66

Starting the engine 66

Starting the engine, starting assistance 203

Status control display, tyres 107

Status information, iDrive 21

Status of the Owner's Handbook 7

Steering support 127

Steering wheel, adjusting 57

Steering wheel heating 57

Stopping the engine 67

Storage compartments 153

Storage options 153

Storage, tyres 178

Storage, vehicle 211

Suitable engine oil grades 187

Summer tyres, tread 176

Sunblinds, sun guard 45

Sun visor 149

Supplementary text message 83

Surround view 133

Switches, see Driving area 12

Switching off the engine 67

Switch-on times, independent ventilation 148

Symbols 6

Symbols in the status field 21

Symbols used 6

System states of the driving dynamics 86

## T

Tailgate opening 38

Tail lights 199

Tank display 84

Technical changes, see Your own safety 7

Technical data 214

Technology, BMW M 160

Telephone 6

Temperature, automatic air conditioning 145

Temperature display, outside temperature 84

Temperature, engine oil 84

Tensioning bands, securing load 166

Text message, supplementary 83

Thiefproof wheel studs 199

Thread for towing eye 207

Through-loading system 151

Tilt alarm sensor 43

Tilting down, passenger's mirror 56

Tool 193

Topping up engine oil 186

Top View 137

Total weight 215

Total weight, permitted 215

Touchpad 19

Tourist function, see Left-hand/right-hand traffic 102

Tow eye, see Towing eye 206

Towing 204

Towing eye 206

Towing truck 205

Tow-starting 204

TPM Tyre Pressure Monitor 107

Tread, tyres 176

Trip distance recorder 84

Triple turn signal 70

Turn indicator rear, changing bulb 196

Turn indicators, operation 70

Turning circle 214

Turning circle lines, rear-view camera 135

Tyre damage 176

Tyre pressure monitoring, see RPA 109

Tyre Pressure Monitor TPM 107

Tyre pressures 175

Tyre replacement 177

Tyre sealant 178

Tyres, everything about wheels and tyres 175

Tyre tread 176

## U

Units of measure 94

Unloaded weight 215

Unlocking/locking using door lock 37

Unlocking/locking with remote control 35

Unlocking, settings 41

Updates after going to press 7

Upholstery care 210

USB interface 150

## V

Vanity mirror 149

Vehicle battery 199

Vehicle battery, changing 199

Vehicle equipment 7

Vehicle for tow-starting/towing 205

Vehicle identification number 9

Vehicle paintwork 209

Vehicle, running in 162

Ventilation 147

Ventilation, see Independent ventilation 147

VIN, see Vehicle identification number 9

Voice control system 25

## W

Wading 163

Warning indicators, see Check control 80

Warning lamp in the exterior mirror, see Lane Change  
Warning 117

Warning messages, see  
Check control 80

Warning triangle 203

Warranty 7

Washer fluid 73

Washer jets, windows 72

Washing the vehicle 208

Water on roads 163

Weights 215

Welcome lights 99

Welcome light when unlocking 35

Wheelbase, vehicle 214

Wheel change 199

Wheel replacement 177

Wheels, everything about  
wheels and tyres 175

Wheels, run flat indicator  
RPA 109

Width, vehicle 214

Windscreen washer jets 72

Windscreen washing system 71

Windscreen wipers, see  
Wiper system 71

Winter storage, care and  
maintenance 211

Winter tyres, right tyres 177

Winter tyres, tread 176

Wiper, fold-out position 72

Wipers 71

Wiper system 71

Wood, care 210

Wordmatch principle, navigation 24

Working in the engine compartment 183

## Y

Your own safety 7

## X

Xenon light, bulb change 194



BMW M



The Ultimate  
Driving Machine

01 40 2 964 013 en

