



2008 Audi A5

Owner's Manual



Introduction

Thank you for choosing an Audi A5 - we value your trust in us.



Your new Audi A5 incorporates the newest technology as well as numerous features designed for your comfort, convenience and safety. We recommend you read your Owner's Manual thoroughly so that you can quickly become acquainted with your Audi.




In addition to explaining how the different features work, we also give you many useful tips and information concerning your safety and that of your passengers, how to care for your vehicle and maintain your vehicle's value.

We hope you enjoy driving your Audi A5 and we wish you safe and pleasant motoring.

AUDI AG

Table of contents

Vehicle literature	5	Power windows	56	Starting and stopping the engine with advanced key	111
About this Owner's Manual	6	Valet parking	58	Electromechanical parking brake .	113
		Panorama roof	59	Cruise control	116
Controls and equipment	9	Clear vision	61	Audi side assist	119
Instruments and controls	11	Lights	61	Lane change assistant	119
General illustration	11	Interior lights	67	Notes	126
Instruments and warning/indicator lights	12	Vision	68	Transmission	129
Instruments	12	Wiper and washer system	70	Manual transmission	129
Warning/indicator lights	16	Mirrors	73	tiptronic® (6-speed automatic transmission)	129
Driver information display	22	Digital compass	76	Audi Parking System	137
Introduction	22	Seats and storage	78	Audi Parking System	137
On-Board Diagnostic system (OBD)	26	General recommendations	78	Audi Parking System (rear, with rear- view camera)	137
Trip computer	27	Adjusting front seats manually ..	79	HomeLink®	145
Speed warning system	30	Easy entry	81	Universal remote control	145
Auto Check Control	31	Power front seat adjustment	81		
Tire pressure monitoring system ..	40	Easy entry	83		
Opening and closing	46	Seat memory	83	Safety first	151
Keys	46	Head restraints	85	Driving Safely	152
Power locking system	49	Front arm rest	86	General notes	152
Opening and closing rear lid/trunk lid	55	Luggage compartment	87	Proper occupant seating positions	154
		Roof rack	92	Driver and passenger side footwell	158
		Beverage holders	94	Pedal area	158
		Ashtrays	95	Stowing luggage	159
		Cigarette lighter/outlet	96	Reporting Safety Defects	161
		Storage	97		
		Warm and cold	99		
		Deluxe automatic climate control plus	99		
		Deluxe automatic climate control plus - basic settings	106		
		Seat heating	107		
		On the road	108		
		Steering	108		
		Ignition lock and ignition switch .	109		

Safety belts	163	Driving with your quattro®	226	Tires and wheels	276
General notes	163	Energy management	227	Tires	276
Why safety belts?	164	Driving and environment	229		
Safety belts	167	The first 1,000 miles (1,500 km) and afterwards	229		
Safety belt pretensioners	170	Catalytic converter	230		
Airbag system	172	Avoid damaging the vehicle	231	Do-it-yourself service ...	297
Important things to know	172	Operate your vehicle economically and minimize pollution	231	What do I do now?	298
Front airbags	176	Trailer towing	234	Trunk escape handle	298
Monitoring the Advanced Airbag System	183	Driving with a trailer	234	Vehicle tool kit	298
Knee airbags	188	Trailer towing tips	236	Tire mobility system	299
Side airbags	191			Space-saving spare tire (compact spare tire)*	300
Side curtain airbags (SIDEGUARD™)	194			Tire repair	301
Child Safety	197	Vehicle care	239	Changing a wheel	304
Important things to know	197	Cleaning and protection	240	Fuses and bulbs	312
Child safety seats	202	General information	240	Fuses	312
Installing a child safety seat	207	Care of exterior	240	Bulbs	316
Lower anchorages and tethers for children (LATCH)	211	Care of interior	247	Emergency situations	317
Additional Information	216	Fuel supply and filling your fuel tank	253	General	317
		Gasoline	253	Starting by pushing or towing	317
Vehicle operation	219	Fuel tank	254	Starting with jumper cables	317
Intelligent technology	220	Checking and filling	258	Use of jumper cables	318
Notice about data recorded by vehicle control modules	220	Engine hood	258	Emergency towing with commercial tow truck	320
Electronic Stabilization Program (ESP)	220	Engine compartment	260	Lifting vehicle	322
Braking	223	Engine oil	261		
Servotronic® - advanced power steering system	225	Engine cooling system	266		
		Brake fluid	269		
		Battery	270		
		Windshield/headlight washer container	275		



Technical data	325
General information	326
Explanation of technical data	326
Vehicle identification	326
Displaying Vehicle Identification Number in the MMI	327
Weights	327
Dimensions	328
Data	329
265 hp, 6-cylinder engine, with all wheel drive	329
Consumer Information	330
Warranty coverages	330
Operating your vehicle outside the U.S.A. or Canada	330
Audi Service Repair Manuals and Literature	330
Maintenance	330
Additional accessories, modifications and parts replacement	332



Alphabetical index	335
---------------------------------	-----

Vehicle literature

In addition to this Owner's Manual, your Audi comes with the

- MMI Operating Instructions
- Warranty & Maintenance booklet.

If you are missing one of these publications, or if you believe that the information is not complete, contact your authorized Audi dealer for assistance.

MMI Operating Instructions

contain detailed description of the Audi Multi Media Interface (MMI) including the navigation system, the sound system and the hand-held phone.

The Warranty & Maintenance booklet

explains how you can keep your Audi in top driving condition by having it serviced regularly and contains detailed information about the warranties covering your Audi. Always have the booklet with you when you take your vehicle to an authorized Audi dealer for service. Your Audi Service Adviser will record each scheduled service and can answer any questions you may have regarding how to maintain your vehicle.

In Canada,

the vehicle literature is also available in French. To obtain a copy, contact your dealer or write to:

Au Canada, on peut se procurer un exemplaire en français de ce document auprès du concessionnaire ou de:

Volkswagen Canada, Inc.
Client Assistance
Assistance à la Clientèle
777 Bayly Street, West,
Ajax, Ontario L1S 7G7

If you sell your Audi

all literature should be left in the vehicle to make the Warranty terms as well as all operating, safety and maintenance information available to the next owner.

If you change your address or if you bought this Audi used

be sure to send in a "Notice of Address Change" / "Notice of Used Car Purchase" post card. This card can be found in the Warranty & Maintenance booklet or obtained from your authorized Audi dealer.

It is in your own interest that we are able to contact you should the need arise. ■

About this Owner's Manual

This owner's manual contains important information, tips, suggestions, and warnings for the use of your vehicle.

Make sure that this owner's manual is always located in the vehicle. This is especially important if you allow other people to drive the vehicle, or if you sell it.

This owner's manual describes the **equipment range** specified for this model at the editorial deadline date. Some of the equipment described here will only be available at a later date, or only in specific markets.

Some sections in this owner's manual do not apply to all vehicles. In that case, the **range of applicability** is given at the beginning of the section, e. g. "Applies to vehicles: with Advanced Parking System". In addition, optional equipment is indicated by an asterisk "*" .

The details in the **illustrations** may be different from those in your vehicle, and are intended to be viewed as a basic guide.

You will find a **table of contents** at the beginning of this book, which displays all topics described in this manual in order of appearance. You will find an alphabetical **index** at the end of this book.

All **directions**, such as "left", "right", "front", "back", are relative to the direction of travel.

* optional equipment

► This section continues on the next page.

■ Indicates the **end of a section**.

® Registered trademarks are identified with a ®. If this symbol is missing, it is no guarantee that the terms can be used freely.

⇒ ⚠ Cross-reference to a "WARNING!" within a section. For indication with a page number, the corresponding "WARNING!" can be found outside of the section.



WARNING

Text with this symbol contains important information on safety and how to reduce the risk of personal injury or death.



Note

Text with this symbol draws your attention to potential sources of damage to your vehicle.



For the sake of the environment

Text with this symbol contains information about the environment and how you can help protect it.



Tips

Text with this symbol contains special tips and other information about getting the most out of your vehicle and its features. ■





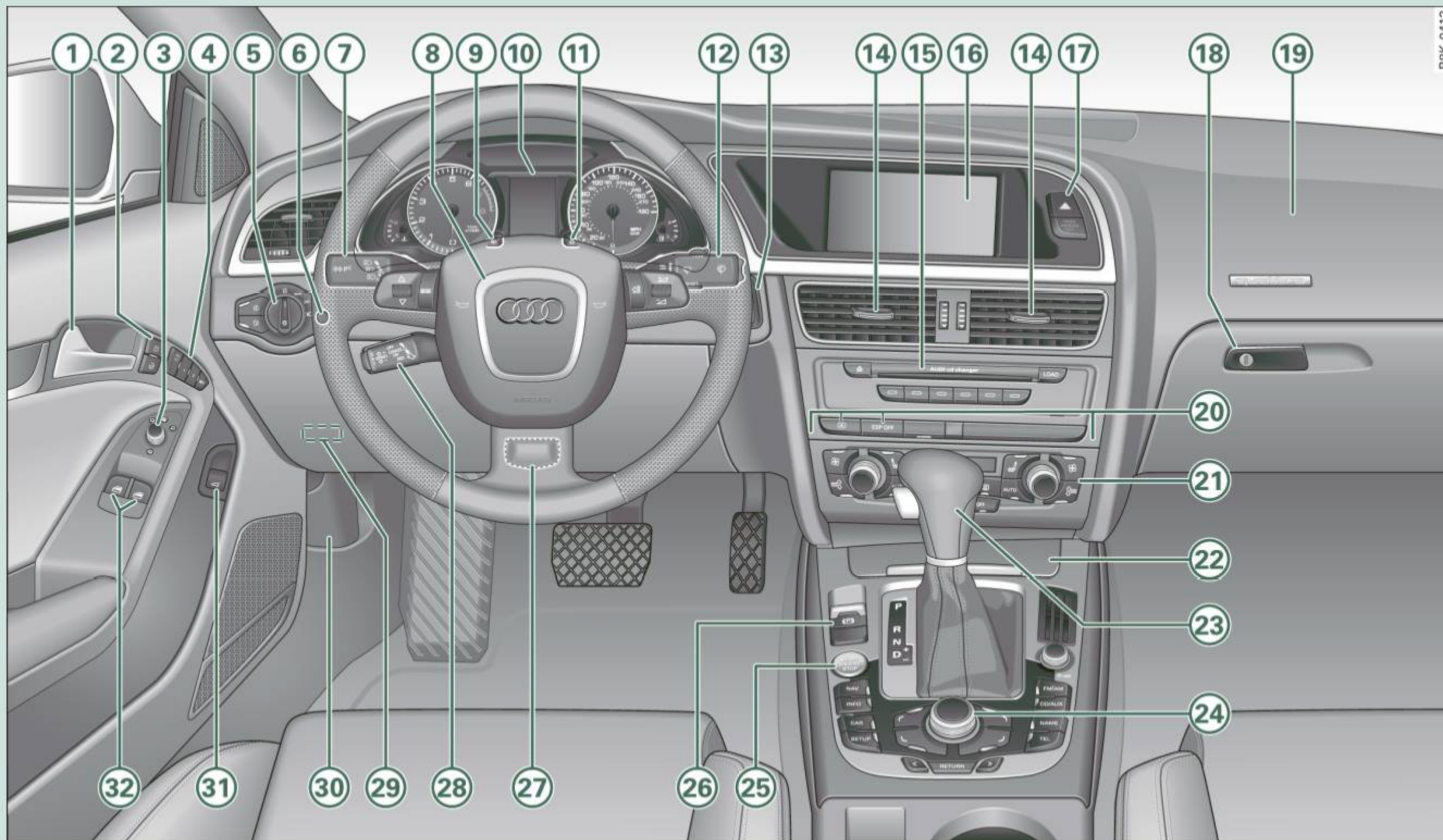


Fig. 1 Some of the equipment or features shown in the general illustration may be standard equipment on your vehicle or may be optional equipment depending on your model. Always ask your authorized Audi dealer if you have a question about your vehicle.

Instruments and controls

General illustration

① Door handle	
② Power locking switch	54
③ Adjuster control for outside mirrors	75
④ Memory buttons (driver's seat)	83
⑤ Light switch	61
⑥ Instrument lighting	64
⑦ Control lever for:	
– Turn signal and high beam	66
⑧ Multifunction steering wheel with:	
– Horn	
– Driver's airbag	176
– Operating buttons for the audio system	
– Rocker switches for tiptronic operation	135
⑨ SET button	13
⑩ Instrument cluster	12
⑪ Reset button for trip odometer	15
⑫ Switches for:	
– Windshield wiper/washer	70
– Trip computer	27
⑬ Ignition lock	109
⑭ Air outlets	105
⑮ Depending on options	
– Radio system	
– CD changer	
⑯ MMI Display	
⑰ Emergency flasher	66
⑱ Glove compartment (lockable)	97
⑲ Front passenger's airbag	176
⑳ Depending on options, switches for:	
– Electronic Stabilization Program (ESP)	220
– Rear window sun shade	69
㉑ Deluxe automatic climate control	99
㉒ Ashtray with cigarette lighter	95, 96
㉓ Depending on options, selector lever or shift lever for	
– Manual transmission	129
– 6-speed automatic transmission	129
㉔ Depending on options:	
– MMI terminal or	
– Electronic Stabilization Program (ESP) switch	220
– Power switch for rear window sun shade	69
㉕ Start/Stop button	111
㉖ Electromechanical parking brake	113
㉗ Adjustable steering column	108
㉘ Cruise control	116
㉙ Data Link Connector for On Board Diagnostics (OBD II)	26
㉚ Release lever for the engine hood	258
㉛ Switch for unlocking the trunk lid	55
㉜ Power window switches	56



Tips

Operation of the Multi Media Interface (MMI) is described in a separate manual. ■

Instruments and warning/indicator lights

Instruments

Instrument cluster and controls

The instrument cluster is your central source of information.

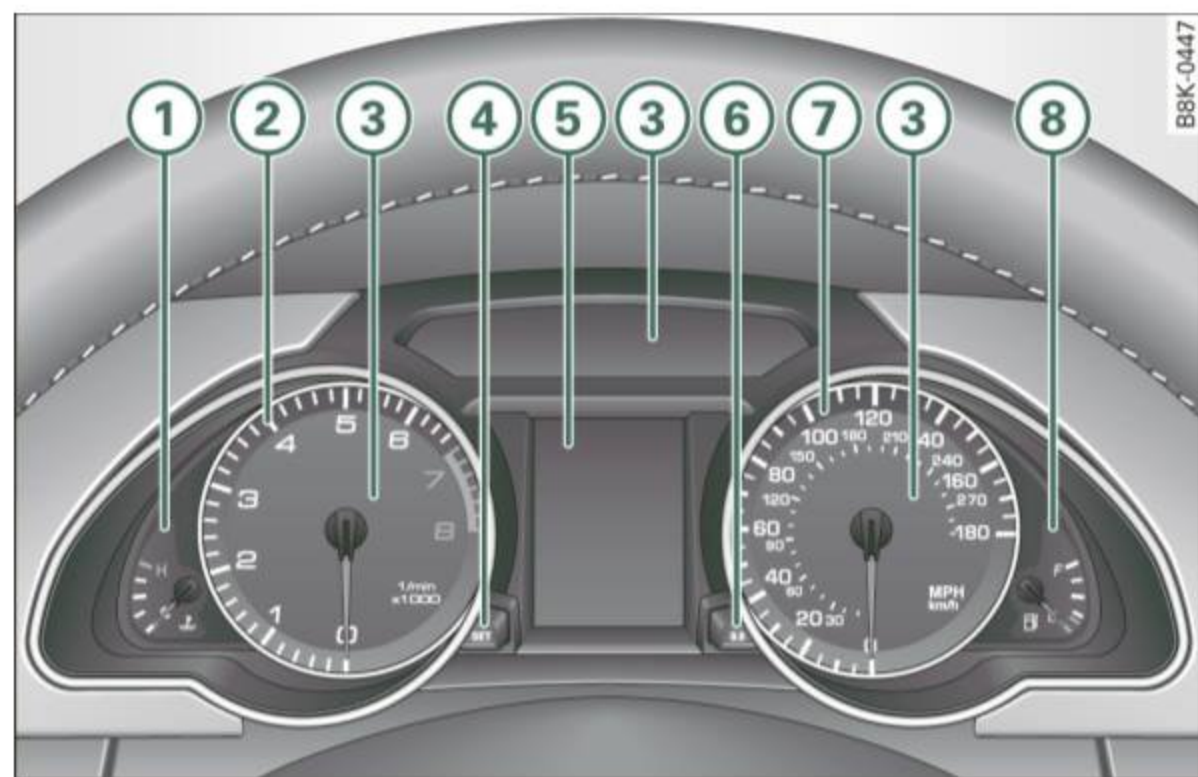


Fig. 2 Overview of the instrument cluster

① Coolant temperature gauge	12
② Speedometer	13
③ Warning/indicator lights	16
④ SET button	13
⑤ Display	
– Driver information system	22
– Time and date display	14
– Odometer	15

⑥ Reset button for trip odometer	15
⑦ Speedometer	
⑧ Fuel gauge	14

i Tips

- When switching the ignition on, the needles in the instrument cluster swing upward briefly.
- The illumination for the instrument cluster lights up whenever you switch on the ignition with the **vehicle headlights off**. As the daylight fades, the instrument cluster illumination likewise dims automatically and will go out completely when the outside light is very low. This feature is meant to remind you to switch on the headlights when outside light conditions become poor. ■



Engine coolant temperature gauge

The engine coolant gauge ⇒ fig. 2 ① only works when the ignition is on. To prevent damage to your engine, please note the following important points:


Engine cold

If the needle is at or close to the bottom of the gauge, the engine has not yet reached its operating temperature. Avoid high engine speeds, heavy engine loads, and heavy throttle applications.

Normal temperature

When the engine has reached its operating temperature, the needle will move to the middle of the gauge and remain there. If the engine is working hard at high outside temperatures, the needle may move higher on the gauge. This is not a cause for concern as long as the  warning light in the instrument cluster display does not illuminate. 

Warning light in the instrument cluster display

If the  warning light in the instrument cluster display flashes, this can mean one of two things: either the coolant *temperature* is too high, or the coolant *level* is too low ⇒ *page 34*.

If the needle is well in the upper area of the gauge, the coolant temperature is too high. **Stop the vehicle, switch the engine off, and allow it to cool.** If the warning light comes on again after driving a short distance, contact an authorized Audi dealer or other qualified workshop.

WARNING

- Always observe the warning in ⇒ *page 251*, “Engine compartment”, before opening the hood and checking the engine coolant level.
- Never open the engine hood if you see or hear steam, or if you see engine coolant dripping from the engine compartment. You could burn yourself. Let the engine cool off first so that you cannot hear or see any steam or engine coolant.

Note


- Mounting additional lights or accessories in front of the air inlets reduces the cooling effect of the radiator. At high outside temperatures or high engine load, the engine could overheat.
- The front spoiler has been designed to properly distribute the cooling air when the vehicle is moving. If the spoiler is damaged, this could reduce the cooling effect and the engine could then overheat. Ask your authorized Audi dealer for assistance. ■

Speedometer (engine rev counter)

The speedometer indicates the engine RPM (revolutions per minutes).

If engine RPM drops below 1,500, you should downshift to the next lower gear. The red area at the end of the scale indicates maximum permissible engine RPM after the break-in period. Before reaching this area, move the selector lever to position “D (Drive)” or ease your foot off the accelerator pedal.

Note

The speedometer needle  ⇒ *page 12*, fig. 2 should only briefly be in the red zone: you could damage your engine! The beginning of the red zone varies depending on the engine.

For the sake of the environment

Upshifting early saves fuel and reduces engine noise. ■

button.

You can perform different functions with this button.

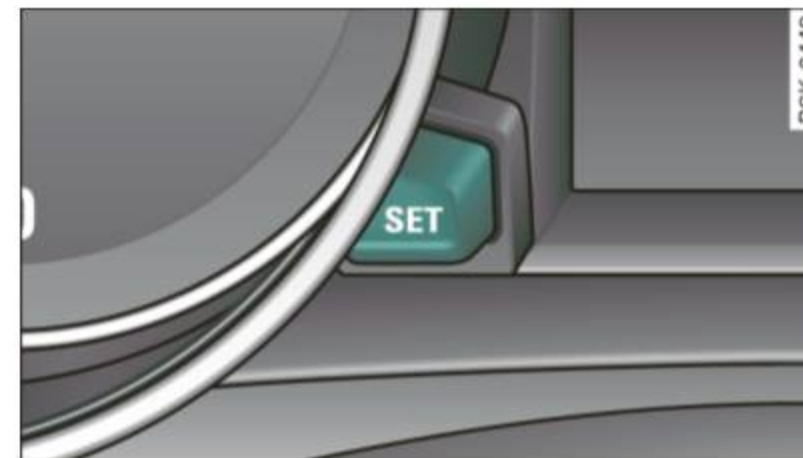




Fig. 3 SET button in the instrument cluster

The  button performs the following functions: 

Switching on time, date, temperature display, and odometer

The display appears for approximately 30 seconds when you press the **SET** button ⇒ *page 13*, fig. 3 with the ignition off.

Starting the Auto-Check sequence

The Auto-Check system ⇒ *page 31* constantly monitors certain individual functions and components of the vehicle when the ignition is turned on and when the vehicle is moving.

With the ignition turned on, you can start the "Auto-Check sequence" by pressing the **SET** button. You can perform an Auto-Check sequence when the vehicle is stationary and the ignition is turned on or when the vehicle is moving slower than 3 mph (5 km/h).

Calling up the driver information

A yellow or red symbol appears in the instrument cluster display, usually with a driver message. The driver message display disappears after about 5 seconds. The driver message can be displayed again by briefly pressing the **SET** button.

Setting the speed warning

By pressing the **SET** button briefly, you can set threshold 1 of the speed warning while you are driving ⇒ *page 30*. By maintaining pressure on the **SET** button, you delete the warning threshold. ■

Digital clock with date display



Fig. 4 Instrument cluster: time and date

Digital clock


The date, time of day, time and date format can be set in the radio or in the MMI*. You can learn more about this in the MMI manual or in the radio user's manual.

i Tips

- The digital clock turns on for about 30 seconds when the driver's door is opened.
- When the ignition is turned off, the odometer reading and the digital clock with date display can be switched on for about 30 seconds by pressing the **SET** button ⇒ *page 13*, fig. 3. ■

Fuel gauge

The fuel gauge works only when the ignition is on.

When the needle reaches the red area, the warning light in the instrument cluster will illuminate ⇒ *page 38* . This means you have approximately 2.1 gallons (8 litres) of fuel left in the tank. **Time to refuel!**

The total tank capacity of your vehicle is listed in ⇒ *page 329*. ►

! Note

Never run the tank completely dry! An irregular supply of fuel can cause engine misfiring and fuel could enter into the exhaust system. The catalytic converter could then overheat and be damaged. ■

Odometer

The odometer indicates the distance driven.



Fig. 5 Instrument cluster: odometer



Fig. 6 Instrument cluster: reset button

The display of distance driven is shown in kilometers "km" or in "miles".

- USA models – Miles

- Canada models – Kilometers

The units of measure (kilometers/miles) can be changed in the MMI or using the **CAR** button on the radio control.

Odometer/trip odometer

The odometer shows the total number of kilometers or miles that have been driven on the vehicle.

The trip odometer shows the distance driven since it was last reset. It can be used to measure short distances. The last digit shows distances of 100 meters or 1/10 of a mile.

The trip odometer can be reset to zero by pressing the reset button **0.0** ⇒ fig. 6.

Malfunction message

If there is a malfunction somewhere in the instrument cluster, **dEF** will appear in the trip odometer and will stay on. Contact your authorized Audi dealer to have the problem corrected.

Immobilizer

When the ignition is switched on, the data on the ignition key are scanned automatically.

If an unauthorized key was used, **SAFE** is displayed permanently in the odometer display field. The vehicle cannot be operated ⇒ page 46.

i Tips

- The date, time, and distance continue to show for about 30 seconds after the ignition is switched off.
- The odometer turns on for about 30 seconds when the driver's door is opened.
- The odometer can be turned on for approximately 30 seconds with the ignition off by pressing the **SET** button ⇒ page 13, fig. 3. ■

Warning/indicator lights



Overview








The warning/indicator lights indicate different functions or a possible malfunction.



Fig. 7 Instrument cluster with warning/indicator lights

Your vehicle is equipped with several important warning and indicator lights to help you monitor the continued reliable operation of your vehicle ⇒ ⚠.

	not available	
EPC	Electronic power control	⇒ page 17
	Electronic Stabilization Program (ESP)	⇒ page 17

AIR BAG	USA models: Airbag system	⇒ page 17
	Canada models: Airbag system	⇒ page 17
	Tire pressure too low	⇒ page 18
	Left turn signal	⇒ page 18
	Safety belt	⇒ page 18
	Malfunction Indicator Lamp (MIL)	⇒ page 18
	High beam	⇒ page 18
	Right turn signal	⇒ page 18
CRUISE	USA models: Cruise control activated	⇒ page 19
	Canada models: Cruise control activated	⇒ page 19
ABS	USA models: Anti-lock brake system (ABS) defective	⇒ page 19
	Canada models: Anti-lock brake system (ABS) defective	⇒ page 19
PARK BRAKE	USA models: Parking brake	⇒ page 20
	Canada models: Parking brake	⇒ page 20
BRAKE	USA models: Brake malfunction	⇒ page 20
	Canada models: Brake malfunction	⇒ page 20

WARNING


- Failure to heed warning lights and other important vehicle information may result in serious personal injury or vehicle damage.
- Whenever stalled or stopped for repair, move the vehicle a safe distance off the road, stop the engine, and turn on the emergency flasher ⇒ *page 66*.
- The engine compartment of any motor vehicle is a potentially hazardous area. Before you check anything in the engine compartment, stop the engine and let it cool down. Always exercise extreme caution when working under the hood ⇒ *page 251*, "Engine compartment"

Tips

Many functions are monitored by the Auto-Check system ⇒ *page 31*. Malfunctions or faults will be identified either with a red symbol (priority 1 – Danger!) or with a yellow symbol (priority 2 – Warning). ■

Electronic power control

This warning/indicator light monitors the electronic power control.

The  warning/indicator light (Electronic Power Control) illuminates when you turn on the ignition as a function check.

Tips

If this warning/indicator light illuminates while you are driving, then there is a malfunction in the engine electronics. Have the malfunction corrected as soon as possible by your authorized Audi dealer or qualified workshop. ■

Electronic stabilization program (ESP)

This warning/indicator light monitors the electronic stabilization program.

The warning/indicator light has the following functions:

- It blinks while you are driving when the ESP is working.
- It illuminates when you switch on the ignition for approximately 2 seconds as a function check.
- It illuminates when there is a malfunction in the ESP.
- It illuminates when ESP or ASR (Anti-Slip Regulation) is deactivated.
- It illuminates if there is a malfunction in the ABS, since the ESP is part of the ABS system.

If the battery terminals were disconnected and re-connected, the vehicle was jump started or the battery is very weak, the ESP sensor system goes through a learning process for the first few yards. The warning/indicator light illuminates. The warning/indicator light goes out as soon as the learning process is complete.



If the ESP warning/indicator light illuminates and stays on after you have started the engine, this may mean that the control system has temporarily switched off the ESP. If this is case, you can reactivate the ESP by turning the ignition off and then on again. The warning/indicator light should go out to show that the system is fully functional again.



For more information about the ESP ⇒ *page 220*. ■

Airbag system

 (USA models) /  (Canada models)

This warning/indicator light monitors the airbag and the pretensioner systems.

The  (USA models) /  (Canada models) warning light illuminates for a few seconds each time you switch on the ignition. ►


If the  (USA models) /  (Canada models) warning light does not go out, or if it illuminates while you are driving, or if it starts to blink, then there is a malfunction somewhere in the system. If the light does not illuminate when you switch on the ignition, this also means there is a malfunction.

WARNING

If you have a malfunction in the airbag system, contact your authorized Audi dealer immediately. Otherwise the airbag or the belt pretensioner may not work properly in an accident. ■

Tire pressure monitoring system - telltale indicator lamp

The warning/indicator light appears in the event of a significant loss of air pressure.

The  warning/indicator light illuminates for a few seconds after the ignition is turned on as function check, and then goes out.



If the  symbol appears, pressure is too low in at least one tire.

When the system detects a malfunction, the warning/indicator light will flash for approximately one minute and then remain continuously illuminated. This sequence will continue upon subsequent vehicle starts up as long as the malfunction exists. Contact your authorized Audi dealer and have the malfunction corrected.

For more information ⇒ *page 42.* ■

Turn signals


The indicator light blinks when you use either turn signal.

Whenever you use the left  or the right  turn signal, the indicator light blinks. When you use the emergency flashers, both indicator lights flash.

If one of the turn signal light bulbs burn out, the turn signal will blink twice as fast as normal. ■

Safety belts

This warning/indicator light reminds you to put on your safety belt.

The  warning/indicator light illuminates when the ignition is switched on to remind the driver and (on USA models only) any front passenger to put on the safety belt. Additionally, an audible warning tone will also sound.

For more Information ⇒ *page 163, "Safety belt warning light .* ■


Malfunction Indicator Lamp (MIL)

The Malfunction Indicator Lamp (MIL) is part of the On-Board Diagnostic (OBD II) system. The symbol  lights up when the ignition is turned on and will turn off after the engine has started and has settled at a constant idle speed. This indicates that the MIL is working properly.

The warning light illuminates when there is a malfunction in the engine electronic system. Contact your authorized Audi dealer and have the malfunction corrected.

For more information ⇒ *page 26.* ■

High beam

The  warning/indicator light illuminates when the high beams are on or when you use the headlight flasher. For more information about using the high beams, see ⇒ *page 66.* ■

Cruise control **CRUISE** (USA models) / (Canada models)

The warning/indicator light illuminates when the cruise control is activated. ■

Anti-lock brake system (ABS) **ABS** (USA models) / (Canada models)

This warning/indicator light monitors the ABS and the electronic differential lock (EDL).

The warning/indicator light will come on for a few seconds when the ignition is switched on. The light will go out after an automatic check sequence is completed.


There is a malfunction in the ABS when:

- The warning/indicator light does not illuminate when you switch on the ignition.
- The warning/indicator light does not go out after a few seconds.
- The warning/indicator light illuminates while driving.

The brake system will still respond even without the assistance of the ABS system. See your authorized Audi dealer as soon as possible to restore full braking performance. For more information regarding the ABS ⇒ *page 224*.

The ABS warning light and the brake warning light come on together. The ABS will not work and you will notice a change in braking response and performance.

Malfunction in the brake system

If the brake warning light ⇒ *page 20* and the ABS warning illuminate *together* there may be a malfunction in the ABS, and there may also be a malfunction in the brake system itself ⇒ .




In the event of a **malfunction in the brake system** the warning/indicator light **BRAKE** (USA models) /  (Canada models) in the instrument

cluster flashes. By pressing the **SET** button, you can bring up a driver message which explains the malfunction in more detail. Please note ⇒ *page 33*.

Malfunction in the electronic differential lock (EDL)

The EDL works together with the ABS. The ABS warning light will come on if there is a malfunction in the EDL system ⇒ *page 221*. See your authorized Audi dealer as soon as possible.

WARNING

- If the **ABS** (USA models) /  (Canada models) warning light does not go out, or if it comes on while driving, the ABS system is not working properly. The vehicle can then be stopped only with the standard brakes (without ABS). You will not have the protection ABS provides. Contact your authorized Audi dealer as soon as possible.
- **USA models:** If the **BRAKE** warning light and the **ABS** warning light come on together, the rear wheels could lock up first under hard braking. Rear wheel lock-up can cause loss of vehicle control and an accident. Have your vehicle repaired immediately by your authorized Audi dealer or a qualified workshop. Drive slowly and avoid sudden, hard brake applications.
- **Canada models:** If the brake warning light  and the ABS warning light  come on together, the rear wheels could lock up first under hard braking. Rear wheel lock-up can cause loss of vehicle control and an accident. Have your vehicle repaired immediately by your authorized Audi dealer or a qualified workshop. Drive slowly and avoid sudden, hard brake applications. ■


Electromechanical parking brake PARK BRAKE (USA models) / (P) (Canada models)

The warning/indicator light monitors the electromechanical parking brake.

With the parking brake applied and the ignition turned on, the warning/indicator light illuminates. After the ignition has been turned off, the warning/indicator light continues to illuminate for about 30 seconds. If the parking brake is applied with the ignition turned off, the warning/indicator light illuminates for about 30 seconds.

The warning/indicator light will go out when the parking brake is released.


If the warning/indicator light flashes continuously **after applying** the parking brake, braking force is not sufficient to prevent the vehicle from rolling unintentionally. Please note the following:

- If the slope of the ground is too steep to park the vehicle, the additional drive message appears **Caution: Vehicle parked too steep**.
- In the event of a parking brake malfunction, the yellow  symbol appears in the instrument cluster display and the driver message **Parking brake malfunction!** is displayed. Have the malfunction repaired as soon as possible by an authorized Audi dealer or any other qualified workshop. ■



Brake system **BRAKE** (USA models) / (!) (Canada models)

The warning/indicator light flashes if brake fluid level is low, if there is an ABS system malfunction or a parking brake malfunction.

The light illuminates when the ignition is turned on. It goes out after the engine has been started. This indicates that the brake warning light is functioning properly.


 If the brake warning light does not light up when the engine is cranking, there may be a malfunction in the electrical system. In this case, contact an authorized Audi dealer.


If the brake system warning/indicator light flashes, there is a brake system malfunction. By pressing the **SET** button, you can bring up a driver message which explains the malfunction in more detail ⇒ *page 33*.

If the ABS fails, the ABS warning/indicator light **ABS** (USA models)/ (Canada models) flashes together with the brake system warning/indicator light ⇒ .

When the light comes on, an audible warning signal is also given.

WARNING

- **USA models:** If the **BRAKE** warning light and the **ABS** warning light come on together, the rear wheels could lock up first under hard braking. Rear wheel lock-up can cause loss of vehicle control and an accident. Have your vehicle repaired immediately by your authorized Audi dealer or a qualified workshop. Drive slowly and avoid sudden, hard brake applications.
- **Canada models:** If the brake warning light (!) and the ABS warning light  come on together, the rear wheels could lock up first under hard braking. Rear wheel lock-up can cause loss of vehicle control and an accident. Have your vehicle repaired immediately by your authorized Audi dealer or a qualified workshop. Drive slowly and avoid sudden, hard brake applications.
- If the brake warning/indicator light does not go out after a few seconds and the parking brake released, or lights up while you are driving, the fluid level in the brake fluid reservoir is too low. If you believe that it is safe to do so, proceed immediately at low speed to the nearest authorized Audi dealer or qualified repair facility and have the brake system inspected.
- Always keep in mind that after several brake applications, you will need greater pressure on the brake pedal to stop your vehicle. Do not rely on strained brakes to respond with maximum stopping

 **WARNING (continued)**

power in critical situations. You must allow for increased braking distances. The extra distance used up by fading brakes could lead to an accident. ■

Driver information display

Introduction

General notes

The driver information display inside the instrument cluster provides you, the driver, with much useful information.



Fig. 8 Instrument cluster: center display

Information from the driver information system is shown in the display in the center of the instrument cluster.

When you turn on the ignition and while you are driving, some functions and vehicle components are scanned for their operating status. Malfunctions or required service procedures are signalled audibly and shown by red and yellow lighted symbols and reminders to the driver in the display.

The driver is also shown information about radio and CD operation and directions for the navigation system*. You can find additional information on these subjects in the MMI manual.

The illustrations in the instrument panel display differ in some of the vehicles.

The driver information system provides the following functions:

Sound system display	⇒ page 23
Outside air temperature	⇒ page 23
Gearshift indicator*	⇒ page 24
Digital speedometer	⇒ page 24
Open door- and luggage compartment warning	⇒ page 25
Service interval display	⇒ page 25
Auto Check system	⇒ page 31
Driver information	⇒ page 32
Speed warning	⇒ page 30
Trip computer	⇒ page 27
Gearshift selector positions Automatic transmission*	⇒ page 131

Tips

In the event of a malfunction either a red or yellow icon appears in the display. Red symbols indicate **Danger** ⇒ page 32. Yellow symbols indicate a **Warning** ⇒ page 36. ■

Sound system display



Fig. 9 Display: sound system

If priority 1 or priority 2 faults are not shown by the Auto Check Control, the name of the radio station you are tuned to or the frequency and the reception range are shown in the upper area of the display.

When the CD is in use, the title of the track being played is shown. The CD changer* displays the number of the current CD (CD1 to CD6). ■

Outside temperature display



Fig. 10 Display: outside temperature

At temperatures below 41° F (+5° C), a snowflake symbol appears in front of the temperature display. It is intended to remind the driver to pay special attention to **ice on the road**.

If your vehicle is stationary or if you are driving at very low speeds, the temperature displayed may be slightly higher than the actual temperature outside due to the heat radiating from the engine.

The unit of measurement for the temperature can be set in either °F or in °C on the MMI* or on the radio control unit. The outside temperature display automatically shows the unit of measurement that has been set. For additional information, see the MMI* or the radio instruction manual.

WARNING

- **Never use the outside temperature display to determine if a road surface is icy or not. Keep in mind that road surfaces, especially bridges and overpasses, could be ice covered and slippery even at an outside temperature above 41 °F (+5 °C).**
- **Always remember, even if the “snowflake” symbol (ice warning) does not appear in the display, black ice could be on the road.**
- **Always reduce your speed and drive with special care in cold weather conditions when the chance of encountering icy road surfaces increases. ■**

Applies to vehicles: with automatic transmission and the gearshift indicator (not ready at the time this went to press)

Gearshift Indicator

This indicator can help conserve fuel.



Fig. 11 Display: Gearshift indicator



Fig. 12 MMI Display: Showing and hiding gearshift recommendation

The radio or MMI can be used to activate or deactivate the gearshift indicator.

Driving information - fading in and out

- Select: Function button **CAR** > Instrument panel > **Shifting recommendation** ⇒ fig. 12.

In order to become familiar with the gearshift indicator, at first just drive the way you are used to. If the current gear—and the driving

situation—is not the best one for conserving fuel, then the indicator will display the recommended gear. The display shows the current gear and the gear that is recommended ⇒ fig. 11.

- **Upshifting** The display will light up to the **right** of the gear currently selected if it is recommending a higher gear.
- **Downshifting:** The display will light up to the **left** of the gear currently selected if it is recommending a lower gear.

Sometimes the indicator will recommend skipping a gear (3 > 5).

If there is no gearshift recommendation, then just drive in the appropriate gear for conserving fuel.

i Tips

- This indicator can help you conserve fuel. This indicator is not meant to show you which gear you should always be in in all driving situations. Sometimes, in situations such as passing, driving through mountains or when towing a trailer, there won't be any gearshift recommendation.
- The display does not light up when the clutch pedal is being depressed. ■

Digital speedometer



Fig. 13 Display: Digital speedometer

Current speed appears in the display. Speed is shown in 1 mph increments (USA models) or 1 km/h increments (Canada models). You can switch the display from miles to kilometers and vice versa via the MMI. ■

Open door or trunk lid warning

The pictogram alerts you when doors or the trunk lid have been left open.



Fig. 14 Display: Open door- and trunk lid warning

The Open Door/Trunk Lid warning displays if even *one* door, the hood or the trunk lid is open. This symbol also shows *which* door or lid has not been closed ⇒ fig. 14.

As soon as the door, the hood and the trunk lid are closed properly, the door and trunk lid warning turns off and the selected driver information system functions are displayed again. ■

Service interval display

The service interval display reminds you when your next service is due.



Fig. 15 MMI display: Service interval display



Fig. 16 Display: Service interval display

The date for service is calculated automatically.

Service inquiry (distance remaining)

The distance remaining to the next service event can be displayed in the MMI ⇒ fig. 15.

If the distance remaining is queried on new vehicles or after service has been performed, the due date within the first 310 miles (500 kilometers) is always shown in the display with the following message.

SERVICE IN ----- MILES (KM) --- DAYS

Service reminder

30 days before the next service is due, a service reminder appears in the display when you turn on the ignition ⇒ *page 25, fig. 16*.

After about 5 seconds the display switches back to normal. The distance and time remaining are updated each time the ignition is turned on until the date due for service is reached.

Service

When the due date for service is reached, the message **Service due !** appears in the display immediately after you turn on the ignition. Additionally, a warning tone sounds. After about 5 seconds the display switches back to normal.




Note

If you disconnect the battery terminals, no calculations can be made for the service interval display during this time and no service reminder will appear. Remember that observing the proper service intervals is vitally important to extending the life of your vehicle, particularly the engine, and maintaining its value. Even if the mileage driven is low, the maximum period of one year from one service to the next must not be exceeded. ■

On-Board Diagnostic system (OBD)

Malfunction Indicator Lamp (MIL)

The Malfunction Indicator Lamp (MIL)  in the instrument cluster ⇒ *page 16, fig. 7* is part of the On-Board Diagnostic (OBD II) system.

The warning/indicator light illuminates when the ignition is switched on and goes out after the engine starts and the idle has stabilized. This indicates that the MIL is working properly.

If the light does not go out after the engine is started, or illuminates while you are driving, a malfunction may exist in the engine system. If the light starts flashing, the catalytic converter could be damaged.

Continue driving **with reduced power** (avoiding sustained high speeds and/or rapid accelerations) and have the condition corrected. Contact your authorized Audi dealer.

If the light illuminates, the electronic speed limiter may also be malfunctioning. For more information ⇒ *page 27, "Electronic speed limiter"*.

An improperly closed fuel filler cap may also cause the MIL light to illuminate ⇒ *page 255*. ■

On-Board Diagnostics

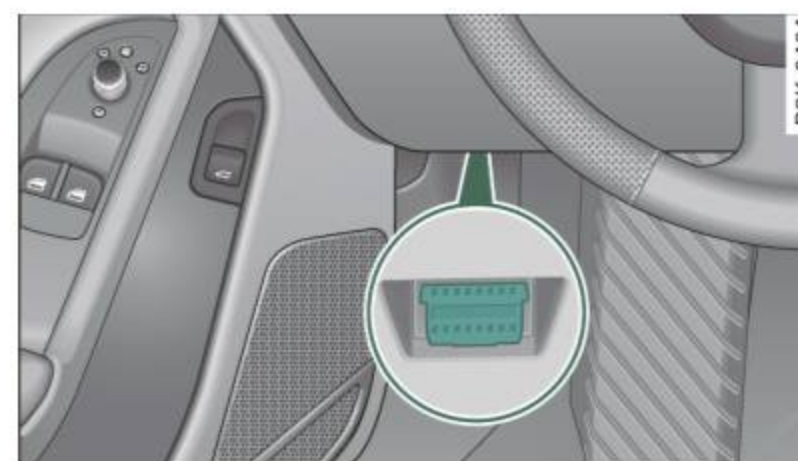


Fig. 17 Location of Data Link Connector (DLC)

On-Board Diagnostics monitors the components of your emission control system. Each monitored component in your engine system has been assigned a code. In case of a malfunction, the component will be identified and the fault stored as a code in the control module memory.

The MIL light may also illuminate if there is a leak in the on-board fuel vapor recovery system. If the light illuminates after a refuelling, stop the vehicle and make sure the fuel filler cap is properly closed ⇒ *page 255*. ►

In order to make an accurate diagnosis, the stored data can only be displayed using special diagnostic equipment (generic scan tool for OBD).


In order to connect the special diagnostic equipment, push the plug into the Data Link Connector (DLC). The DLC is located to the right of the hood release ⇒ *page 26*, fig. 17.

Your authorized Audi dealer or qualified workshop can interpret the code and perform the necessary repair. ■

Electronic speed limiter

Your vehicle may be factory equipped with tires that are rated for a maximum speed of 130 mph (210 km/h). This is less than the maximum speed of your vehicle. To reduce the risk of sudden tire failure and loss of control if the vehicle is operated at excessive speeds, your vehicle also has an electronic speed limiter. The electronic speed limiter prevents your vehicle from going faster than the tire speed rating. For more information ⇒ *page 288*.

If the vehicle approaches the tire speed rating, the engine control unit will turn off the fuel injectors. You will notice an immediate loss of engine power and a drop in road speed.

If the engine control unit receives faulty vehicle roadspeed signals, the Malfunction Indicator Lamp (MIL)  will illuminate. If this occurs, contact the nearest authorized Audi dealer for assistance.

WARNING

Always observe the posted speed limits and adjust your speed to suit prevailing road, traffic and weather conditions. Never drive your vehicle faster than the maximum speed rating of the tires installed. ■

Trip computer

Introduction

The trip computer gives you information on current and average fuel mileage, average speed, fuel range and driving time.



Fig. 18 Trip computer display: Fuel range



Fig. 19 Trip computer display: Average fuel mileage

The following information is continuously evaluated by the trip computer and can be displayed sequentially in the instrument cluster display:

Fuel range

The estimated cruising range in miles (km) appears in the display. This tells you how far your vehicle will be able to travel on the 

current tank of fuel and with the same driving style. The display changes in increments of 6 miles (10 km).

The cruising range is calculated based on the fuel consumption for the last 18 miles (30 km). If you drive conservatively, the cruising range will increase.

Average fuel mileage

The average fuel economy in MPG (l/100 km) since you last cleared the memory appears in this display. You can use this display to adjust your driving technique to achieve a desired mileage.

Current fuel mileage

The instantaneous fuel consumption in miles per gallon (l/100 km) is shown in this display. You can use this display to adjust your driving technique to achieve a desired mileage.

Fuel consumption is recalculated at intervals of 33 yards (30 meters). This display switches to gallons/hour (liters/hour) when the vehicle is not moving.

Average speed

The average speed in mph (km/h) since the last time the display was reset appears in the display.

Elapsed time

The length of time that you have been driving since you last reset the memory appears in this display.

Distance

The distance that has been covered since the last time the memory was cleared appears in the display.



Tips

- Fuel consumptions (average and current), range and speed are displayed in metric units on Canadian models.
- All stored values will be lost if the vehicle battery is disconnected. ■

Memories

The trip computer is equipped with two fully automatic memories.



Fig. 20 Trip computer display: memory level 1

You can switch between the trip computer 1 and 2 by pressing the Reset button **B** ⇒ page 29, fig. 21.

You can tell which memory level is currently active by the number in the display ⇒ fig. 20. The data from the single-trip memory (memory level 1) is being displayed if a **1** appears in the display. If a **2** is shown, then the data from the total-trip memory is being displayed (memory level 2).

Single-trip memory (Trip computer 1)

The single-trip memory stores the trip information from the time the ignition is turned on until it is turned off. If the trip is continued **within 2 hours** from the time the ignition was turned off, the new data will be included in the calculation of the current trip information. If the trip is interrupted for **more than 2 hours** the memory is reset automatically.

Total-trip memory (Trip computer 2)

Unlike the single-trip memory, the total-trip memory is not reset automatically. This permits you to evaluate your driving data for the entire period between manual resets. ■

Operation

The trip computer is controlled by two switches on the windshield wiper lever.



Fig. 21 Windshield wiper lever: controls for the trip computer

- Push the function selector switch up or down (A) ⇒ fig. 21. This will cause the five distinct trip computer functions to be displayed one after another.

The trip computer will not operate unless the ignition is on. When you turn on the ignition, the function that was in use when you last turned the ignition off will be displayed.

In addition to information on the on-board computer (on-board computer 1 or 2), the digital speedometer and information regarding the navigation system* can also be displayed. To switch the display between the different information, tap the Reset button (B) briefly.

Setting values to zero

To delete **one** current value from the trip computer, select the desired function and press the Reset button (B) for at least one second. The following values can be set to zero **individually** using the Reset button:

- Average fuel mileage
- Average speed

- Elapsed time
- Distance

In addition, **all** the values in the single-trip or the total-trip memory can be deleted simultaneously ⇒ page 29.

Tips

All stored values will be lost if the vehicle battery is disconnected. ■

Basic Settings for the on-board computer

The MMI* or the radio operating unit is used for setting the on-board computer's basic settings.



Fig. 22 MMI Display: Trip computer

- Select: Function button (CAR) > Instrument panel > Trip computer 1 or Trip computer 2.

The values in the single-trip or the total-trip memory can all be reset to zero at the same time under **Reset** in the menu.

In addition, you can determine what information from the trip computer should be shown in the instrument cluster display. If one of the pieces of driver information is turned **off**, that driver information will not be shown in the display. The information will continue to be calculated by the trip computer and can be turned back **on** at any time. ■

Speed warning system

Overview

The speed warning system helps you to keep your driving speed below a set speed limit.

The speed warning system warns if the driver exceeds a previously stored maximum speed. A warning tone will sound as soon as the vehicle speed exceeds the set speed by about 3 mph (3 km/h). At the same time, a warning symbol appears in the display. The symbol's appearance might be different in some models.

The speed warning system has **two warning thresholds** that function independently of each other and that have somewhat different purposes:

Speed warning 1

You can use speed warning 1 to set the maximum speed while you are driving. This setting will remain in effect until you turn off the ignition, assuming that you have not changed or reset the setting.



The speed warning symbol  (USA models)/ (Canada models) in the warning 1 display appears when you exceed the maximum speed. It goes out when the speed falls below the stored maximum speed.

The speed warning symbol will also go out if the speed *exceeds* the stored maximum speed by more than about 25 mph (40 km/h) for at least 10 seconds. The stored maximum speed is deleted.

Setting speed warning 1 ⇒ *page 30*.

Speed warning 2

Storing warning 2 is recommended if you *always* want to be reminded of a certain speed, for example when you are traveling in a country that has a general maximum speed limit, or if you do not want to exceed a specified speed for winter tires.

The speed warning 2 symbol,  (USA models)/ (Canada models) appears in the display when you exceed the stored speed limit. Unlike warning 1, it will not go out until the vehicle speed drops below the stored speed limit.

Setting speed warning 2 ⇒ *page 31*.

Tips

Even though your vehicle is equipped with a speed warning system, you should still watch the speedometer to make sure you are not driving faster than the speed limit. ■

Speed warning 1: setting a speed limit

Warning threshold 1 is set by the  button.

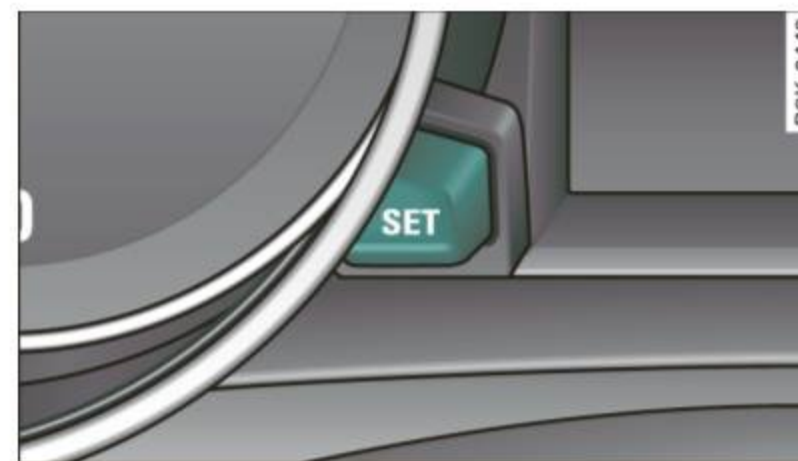



Fig. 23 SET button in the instrument cluster

Storing the maximum speed

- Drive at the desired maximum speed.
- Press the  button in the instrument panel display ⇒ *fig. 23* for 1 second.

Resetting the maximum speed

- Drive the vehicle at a speed of at least 3 mph (5 km/h) ►

- Press the **SET** button for more than 2 seconds.

The speed warning symbol  (USA models)/ (Canada models) will appear briefly in the display when you release the **SET** button to indicate that the maximum speed has been stored successfully.

The maximum speed remains stored until it is changed by pressing the **SET** button again briefly or until it is deleted by a lengthy push on the button. ■

Speed warning 2: setting a speed limit

The MMI or the radio control unit is used to set, change or delete warning threshold 2.*

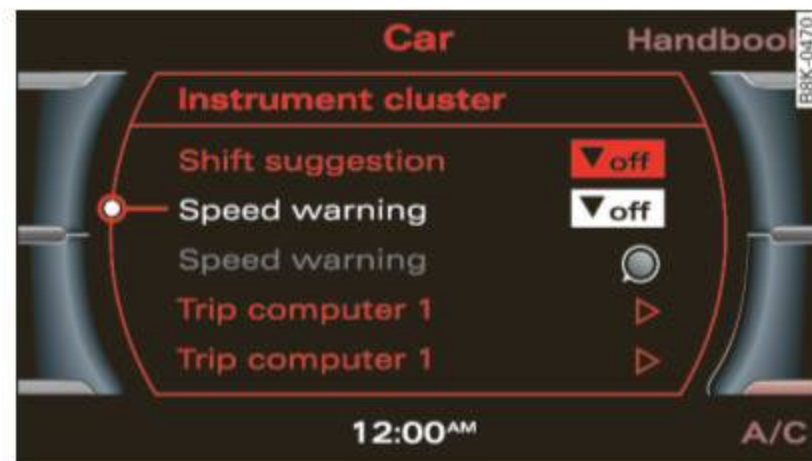


Fig. 24 MMI display:
Set warning threshold 2

- Select: Function button **CAR** > Instrument panel > Speed warning.
 - **Speed warning** - the warning threshold can be turned on or off ⇒ fig. 24.
 - **Speed warning** - a warning tone will sound if you exceed the speed you have set.

Warning threshold 2 can be set in the speed range starting from 18 mph to 150 mph (30 km/h to 240 km/h). Settings can each be adjusted in intervals of 6 mph (10 km/h). ■

Auto Check Control

Introduction

The Auto-Check control monitors the function of certain vehicle features and components. It simply makes sure these features and components are working properly. The Auto-Check control works as long as the ignition is on, as well as whenever the vehicle is driven.

If a component is malfunctioning or if the need for an urgent repair has been detected, this will appear in the instrument cluster display. You will also hear an audible warning tone. The displays are color coded in either red or yellow depending on their level of priority.

A red symbol means **Danger**, a yellow symbol indicates **Warning**. In certain situations, information message for the driver appear in addition to the red and yellow symbols.

Function test: automatic transmission*

The Auto-Check Control will automatically perform a test each time you switch on the ignition. With the selector lever in **P** or **N**, the following message appears in the display:

When stationary apply footbrake while selecting gear.

When you select a different gear (for example: **R**, **D**, etc.), the message will disappear and the Auto-Check function is displayed.

If there is a malfunction, then the malfunction message will appear about 15 seconds after you start the vehicle. At the same time you will hear a warning tone. ■

Driver information messages

Driver information messages are shown in the instrument cluster display in addition to symbols.

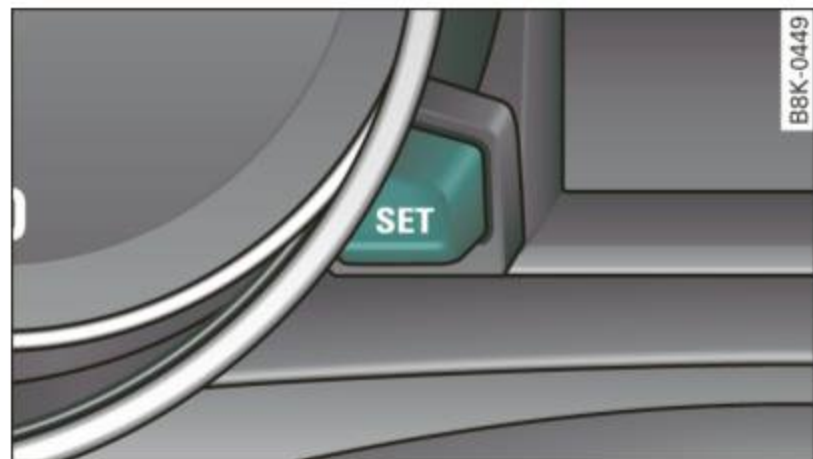


Fig. 25 Instrument cluster: SET button


For example, if the transmission selector lever is not in the P position when the engine is turned off, the following message appears:

Shift to P, otherwise vehicle can roll away. Doors do not lock if lever is not in P.

The ignition key can only be removed with the selector in this position. This and other messages are brought up if a function cannot be carried out.

Driver messages and red symbols

If a red symbol appears in the display, a driver message is also displayed automatically.


For example, the symbol for a problem with engine oil pressure  appears in the display. The message:

Switch off engine and check oil level

The driver message in the display goes out after about 5 seconds. The driver message can be displayed again by briefly pressing the **SET** button ⇒ fig. 25.

Driver messages and yellow symbols

If a yellow symbol appears in the display, a driver message is also displayed automatically.

For example, the symbol  appears in the display, indicating low windshield washer fluid level. The following message also appears:

Please top up washer fluid

The driver message disappears after a few seconds. The driver message can be displayed again by briefly pressing the **SET** button. ■

Red symbols

A red symbol means DANGER.



Fig. 26 Display: Danger symbol








- Pull off the road.
- Stop the vehicle.
- Turn off the engine.
- Check the malfunctioning system. Contact your authorized Audi dealer or a qualified workshop for assistance.

Red symbols indicate a priority 1 malfunction - Danger! 


With a priority 1 malfunction, a red symbol appears in the upper center area of the display ⇒ *page 32*, fig. 26. A driver message appears as well to explain the malfunction in more detail. When this symbol appears, *three* warning tones sound in succession. The symbol continues to flash until the fault has been corrected.

If *several* priority 1 malfunctions are present, the symbols appear in succession and remain for about 2 seconds.

The driver warning goes out after about 5 seconds, but it can be brought up again at any time by pressing the **SET** button. ⇒ *page 32*

	Alternator failure	⇒ <i>page 33</i>
BRAKE	USA models: Brake system malfunction	⇒ <i>page 33</i>
	Canada models: Brake system malfunction	⇒ <i>page 33</i>
	Engine coolant level too low/engine coolant temperature too high	⇒ <i>page 34</i>
	Engine oil pressure too low	⇒ <i>page 35</i>
	Refill engine oil now	⇒ <i>page 35</i>
	Steering malfunction	⇒ <i>page 36</i>
	Ignition lock malfunction	⇒ <i>page 36</i>


Alternator Malfunction

If the  symbol in the instrument panel display flashes, then there is a malfunction in the alternator or the vehicle electronics. A warning to the driver will appear, too. The driver warning goes out

after about 5 seconds, but it can be brought up at any time by pressing the **SET** button again.


Usually, you can still drive to the next dealership. Turn off all but the most necessary electrical consumers, since these drain the vehicle's battery.

Note

If the  warning symbol (coolant system malfunction) also lights up on the instrument panel during the trip ⇒ *page 34*, then you have to stop immediately and turn off the engine. The coolant pump is not working anymore--danger of damage to the engine! ■

Brake system malfunction


A malfunction in the brake system must be repaired as soon as possible.

If the **warning/indicator light BRAKE** (USA models)/ (Canada models) in the instrument cluster flashes, there is a brake system malfunction. A driver message appears as well to explain the malfunction in more detail. The driver warning goes out after about 5 seconds, but it can be brought up at any time by pressing the **SET** button again.

Stop the Vehicle and Check the Brake Fluid


- Stop the vehicle.
- Check the brake fluid level ⇒ *page 269*.
- Seek professional assistance if necessary.

Caution! Brake malfunction (ABS) Get it serviced



- Drive carefully to the nearest authorized Audi dealer or other qualified workshop and have the malfunction corrected ⇒ .

Parking brake Please get to a repair shop

- If this symbol appears when the vehicle is stationary or after the ignition is turned on, check to see if the parking brake can be released. Drive to an authorized Audi dealer or other qualified workshop as soon as possible and have the malfunction corrected. If the parking brake cannot be opened, then take it to an expert at an authorized Audi dealer.
- If the symbol appears while you are driving, it is possible that the traction control or the emergency brake has malfunctioned. It is possible that the parking brake cannot be applied. It is also possible that the parking brake cannot be released after it has been applied. Drive to an authorized Audi dealer or other qualified workshop to have the malfunction corrected.

If the ABS system malfunctions, the ABS warning/indicator light illuminates together with the brake system malfunction warning/indicator light ⇒ .

WARNING


- Always observe the warnings in ⇒ *page 251*, “Engine compartment”, before opening the hood and checking the brake fluid.
- Driving with low brake fluid is a safety hazard. Stop the car and get professional assistance.
- **USA models:** If the **BRAKE** warning light and the **ABS** warning light come on together, the rear wheels could lock up first under hard braking. Rear wheel lock-up can cause loss of vehicle control and an accident. Have your vehicle repaired immediately by your authorized Audi dealer or a qualified workshop. Drive slowly and avoid sudden, hard brake applications.
- **Canada models:** If the brake warning light  and the ABS warning light  come on together, the rear wheels could lock up

WARNING (continued)

first under hard braking. Rear wheel lock-up can cause loss of vehicle control and an accident. Have your vehicle repaired immediately by your authorized Audi dealer or a qualified workshop. Drive slowly and avoid sudden, hard brake applications. ■


Engine cooling system malfunction

A malfunction in the engine cooling system must be repaired as soon as possible.

If the  symbol flashes in the display, either the engine coolant *temperature* is too high or the engine coolant *level* is too low. A driver message appears as well to explain the malfunction in more detail. The driver warning goes out after about 5 seconds, but it can be brought up at any time by pressing the **SET** button again.

Switch off engine and check coolant level


- Pull off the road.
- Stop the vehicle.
- Turn off the engine.
- Check coolant level ⇒ *page 267*.
- Add coolant if necessary ⇒ *page 268*.
- Continue driving only after the engine coolant warning/indicator light goes out.
- Contact your authorized Audi dealer for assistance if necessary.

If the engine coolant level is correct, then the radiator fan may be the cause of the malfunction. 

WARNING


- If your vehicle should break down for mechanical or other reasons, park at a safe distance from moving traffic, turn off the engine and turn on the hazard warning lights ⇒ *page 66*, “Emergency flashers ▲”.
- Never open the hood if you see or hear steam or coolant escaping from the engine compartment - you risk being scalded. Wait until you can no longer see or hear steam or coolant escaping.
- The engine compartment of any vehicle is a dangerous area. Before you perform any work in the engine compartment, turn off the engine and allow it to cool. Follow the warning stickers ⇒ *page 251*, “Engine compartment”.

Note

Do not continue driving if the  symbol illuminates. There is a malfunction in the engine cooling system – you could damage your engine. ■

Engine oil pressure malfunction

The red engine oil pressure warning symbol requires immediate service or repair. Driving with a low oil pressure indication is likely to cause severe engine damage.

If the  symbol on the display flashes, the engine oil pressure is too low. A driver message appears as well to explain the malfunction in more detail. The driver warning goes out after about 5 seconds, but it can be brought up at any time by pressing the **SET** button again.

Switch off engine and check oil level


- Stop the vehicle.

- Turn the engine off.
- Check the brake fluid level ⇒ *page 263*.
- Seek professional assistance if necessary.

Engine oil level too low





If the engine oil level is too low, add engine oil ⇒ *page 264*.

Engine oil level correct

If the symbol  flashes even though the engine oil level is correct, please seek professional assistance. Do not continue driving. Do not leave the engine running **idle, either**.




Tips

- The engine oil pressure symbol  is not an indicator for a low engine oil level. Do not rely on it. Instead, check the oil level in your engine at regular intervals, preferably each time you refuel, and always before going on a long trip.
- The yellow oil level warning indication  requires oil refill or workshop service without delay. Do not wait until the red oil pressure warning  starts to flash before you respond to the low oil level warning . By then, your engine may already have suffered serious damage. ■


Fill engine oil now

Please replenish oil now

If the  symbol lights up, then the oil has to be replenished right now ⇒ *page 264*. ■

Steering Malfunction

If there is a malfunction in the electronic steering column lock, the steering cannot be unlocked.

If the  symbol in the display blinks, there is a malfunction in the electronic steering column lock. A driver message appears as well to explain the malfunction in more detail. The driver warning goes out after about 5 seconds, but it can be brought up at any time by pressing the **SET** button again.

Stop the vehicle and turn off the engine. Steering defective

- Obtain professional assistance.
- Do **not** tow your vehicle.

WARNING


Your vehicle must not be towed in the event of a malfunction in the electronic steering column lock because it cannot be steered due to the locked steering. If it is towed with the steering locked, there is the risk of an accident.

Tips

The symbol's appearance might be different in some models. ■

Ignition lock malfunction

A malfunction in the ignition lock must be repaired immediately.

If the  symbol in the display blinks, there is a malfunction in the electronic ignition lock. A driver message appears as well to explain the malfunction in more detail. The driver

warning goes out after about 5 seconds, but it can be brought up at any time by pressing the **SET** button again

Defective ignition switch Get it serviced!

- Do **not** turn the engine off.
- Drive immediately to an authorized service facility to have the malfunction corrected.

If there is a malfunction in the electronic ignition lock, the ignition cannot be turned off. Drive immediately to an authorized service facility to have the cause of the malfunction corrected.

On vehicles with advanced key*, the engine should not be switched off using the start/stop button because the engine cannot be started again after the ignition has been switched off.

Tips

The symbol's appearance might be different in some models. ■

Yellow symbols

A yellow symbol means WARNING.














Fig. 27 Display: Yellow warning symbol






Yellow symbols indicate a priority 2 malfunction - Warning! ►

When a yellow warning symbol appears, *one* warning tone sounds. A driver message appears as well to explain the malfunction in more detail. The driver warning goes out after about 5 seconds, but it can be brought up at any time by pressing the **SET** button again.



Check the function displayed as soon as possible. The yellow symbol will not go out again until the reason for the malfunction has been corrected.

If several priority 2 malfunctions are present, the symbols appear in succession and remain for about 2 seconds.

	Worn brake pads	⇒ page 38
	Battery voltage	⇒ page 39
	Defective light bulb*	⇒ page 38
	Check engine oil level	⇒ page 39 or ⇒ page 39
	Engine oil sensor malfunction	⇒ page 39
	Low fuel level	⇒ page 38
	Windshield washer fluid level low	⇒ page 38
	advanced key* Key not in vehicle	⇒ page 37
	Light/rain sensor defective	⇒ page 38
	Dynamic headlight range control defective	⇒ page 39
	Battery in remote control key	⇒ page 47

	Electromechanical parking brake	⇒ page 116
	adaptive light defective	⇒ page 39
	Ignition lock malfunction	⇒ page 39
	Windshield wiper defective	⇒ page 40
	Significant loss of air pressure	⇒ page 42
TPMS	Tire pressure monitoring system (malfunction)	⇒ page 44


Tips

The speed warnings warning threshold 1  and warning threshold 2  are also yellow symbols in some models. The warning is always shown as a small symbol in the upper area of the display ⇒ page 30. ■

Applies to vehicles: with advanced key

Key not in vehicle

Key not in vehicle

This reminder appears along with the  symbol if the master key is removed from the vehicle with the engine running. It is intended to remind you (e.g. when changing drivers) not to continue the journey without the master key.

If the master key is no longer in the vehicle, you cannot switch off the ignition after stopping the engine and you also cannot start the engine again. You also cannot lock the vehicle from the outside. ■


Light/rain sensor defective

Automatic headlights/automatic wipers defective

If the symbol illuminates, the light sensor has failed. For safety reasons the low beams are turned on permanently with the switch in **AUTO**. However, you can continue to turn the lights on and off using the light switch. In the case of a defect in the rain sensor, the windshield wiper lever functions are still available. Have the light/rain sensor checked as soon as possible by an authorized Audi dealer. ■

Worn brake pads

Brake pads!

If the symbol  illuminates, contact your authorized Audi dealer to have the front brake pads inspected (on that occasion have the rear brakes inspected as well to be safe). ■


Applies to vehicles: with defective light bulb warning

Defective light bulb warning

The defective light bulb warning monitors the function of the light bulbs in the vehicle.

The defective light bulb warning monitors the function of the light bulbs. If a defective light bulb is detected, or if a light bulb has burned out, a yellow symbol appears as well as a notification that shows which light bulb is defective.

Defective bulb

If this symbol  lights up, a turn signal (front or rear), a headlamp, a brake light, the back-up light, a fog lamp or a rear fog lamp has failed.

WARNING

- Light bulbs are under pressure and can explode when bulbs are replaced - risk of injury.
- With gas-discharge lamps* (xenon headlights), the high-voltage component must be handled appropriately. Doing otherwise poses a risk of death!

Tips


Have an authorized Audi dealer or other qualified workshop perform the replacement or the repair. ■

Windshield washer fluid level too low

Top off the washer fluid

If the symbol illuminates, add windshield washer fluid to the washer system and also to the headlight washer system ⇒ *page 275*. ■


Fuel supply too low

When the  symbol illuminates, this means there are about 2.1 gallons (8 liters) of fuel left in the fuel tank. Time to refuel!
⇒ *page 254*.

If the symbol lights up, even when there is ample fuel in the tank, and the text **TANK SYSTEM MALFUNCTION ! CONTACT WORKSHOP** appears in the display, there is a fault in the system. Contact a qualified workshop to have the fault rectified. ■

Applies to vehicles: with battery voltage warning

Battery voltage

If battery power drops into the range where it can limit the ability of the engine to start, this the symbol  appears in the instrument cluster display with the following driver message **battery charge low: Indicates charging by being driven**.

While this driver notification is displayed, you have to be prepared for limited starting capability.

Driver message appears and goes out again


If this driver message appears after the ignition is turned on or while driving and it goes out again after a while, the battery has been adequately recharged.

Driver message appears and does not go out again

If this driver notification appears after the ignition is turned on or while driving and does not go out again, the battery's state of charge is not in the optimal range. Starting capability is restricted. Have the battery checked at an authorized Audi dealer or other qualified workshop as soon as possible. ■

Check engine oil (without the dipstick)

 Please top off with max. 1L of oil. You can keep driving.

If the  symbol lights up displaying this driver message, then add a maximum of 1 liter at your earliest opportunity ⇒ *page 264*. ■

Engine oil level

 Please check oil level

When the symbol illuminates, check the engine oil level as soon as possible ⇒ *page 263*. Top off the oil at your earliest opportunity ⇒ *page 264*. ■


Engine oil sensor defective

 Oil level! Sensor defective

If the symbol illuminates, contact your authorized Audi dealer and have the oil sensor inspected. Until you have this done, check the oil level each time you refuel just to be on the safe side ⇒ *page 263*. ■

Headlight range control defective


 Headlight range control defective !

If the symbol  illuminates, the dynamic headlight range control is no longer working properly. Have the system checked and repaired at your authorized Audi dealer. ■

Applies to vehicles: with adaptive light


Adaptive light defective

 Adaptive Light defective

When this symbol  illuminates, it means that adaptive light is defective. Go to an authorized Audi dealer to have the headlights or the control unit for the adaptive light repaired. ■


Ignition lock malfunction

 Ignition lock defective

If the  symbol in the display comes on, there is a malfunction in the electronic ignition lock. Please go to an authorized Audi dealer or other qualified workshop to have the malfunction repaired. ■

Windshield wipers faulty

Windscreen wiper defective !

When this symbol  illuminates, it means that the electronics for the windshield wipers are defective. Please go to an authorized Audi dealer or qualified workshop to have the windshield wiper system repaired. ■

Tire pressure monitoring system

General notes

As an added safety feature, your vehicle has been equipped with a tire pressure monitoring system (TPMS) that illuminates a low tire pressure telltale when one or more of your tires is significantly under-inflated. The TPMS only provides a low tire pressure warning and does not reinflate your tires.

Accordingly, when the low tire pressure telltale illuminates, you should stop and check your tires as soon as possible, and inflate them to the proper pressure. Driving on a significantly under-inflated tire causes the tire to overheat and can lead to tire failure.

Under-inflation also reduces fuel efficiency and tire tread life, and may affect the vehicle's handling and stopping ability.

Note

- Please note that the TPMS is not a substitute for proper tire maintenance, and it is the driver's responsibility to maintain correct tire pressure, even if under-inflation has not reached the level to trigger illumination of the TPMS low tire pressure telltale.
- Each tire, including the spare, should be checked monthly when cold and inflated to the inflation pressure recommended by the vehicle manufacturer on the vehicle placard or tire inflation pressure label. (If your vehicle has tires of a different size than the size

indicated on the vehicle placard or tire inflation pressure label, you should determine the proper tire inflation pressure for those tires.) ■

TPMS malfunction indicator


Your vehicle has also been equipped with a TPMS malfunction indicator to indicate when the system is not operating properly. The TPMS malfunction indicator is combined with the low tire pressure telltale. When the system detects a malfunction, the telltale will flash for approximately one minute and then remain continuously illuminated. This sequence will continue upon subsequent vehicle starts up as long as the malfunction exists.

When the malfunction indicator is illuminated, the system may not be able to detect or signal low tire pressure as intended.

TPMS malfunctions may occur for a variety of reasons, including the installation of replacement or alternate tires or wheels on the vehicle that prevent the TPMS from functioning properly. Always check the TPMS malfunction telltale after replacing one or more tires or wheels on your vehicle to ensure that the replacement or alternate tires and wheels allow the TPMS to continue to function properly. ■

Introduction

The tire pressure monitoring system monitors air pressure in all four road wheels while the vehicle is moving.

As soon as the tire pressure monitoring system senses a significant loss of air pressure in one or several tires, text messages and yellow symbols appear in the instrument cluster display to alert the driver. The  warning light in the instrument cluster comes on when the tire is significantly underinflated ⇒ *page 18*.

The warning light  also illuminates in the case of a system malfunction. ►

Be aware that tire pressure is also dependent on the temperature of the tire. For every 18 °F (10 °C) increase in tire temperature, tire pressure increases by about 1.5 psi (0.1 bar). The tire warms up while the vehicle is moving and tire pressure rises. So you should adjust tire pressure only when they are *cold*, when the temperature of the tires is roughly the same as the ambient air temperature.

In order to keep the tire pressure monitoring system properly calibrated, tire pressure on all four tires should be checked at regular intervals, adjusted if necessary and saved in the proper setting (recommended pressure) ⇒ *page 42*.

The tire pressure is shown on the label located on the driver's side B-pillar (visible when the door is open).

WARNING

- **When the tire pressure monitoring system warning light is lit, one or more of your tires is significantly under-inflated. You should stop and check your tires as soon as possible, and inflate them to the proper pressure as indicated on the vehicle's tire pressure label ⇒ *page 280*. Driving on a significantly under-inflated tire causes the tire to overheat and can lead to tire failure. Under-inflation also is likely to impair the vehicle's handling and stopping ability.**
- **Do not adjust tire pressure when tire temperature is excessive. This could lead to serious tire damage and even cause the tire to burst, with the additional danger of an accident.**

For the sake of the environment

Driving with under-inflated tires reduces fuel efficiency and tire tread life.

Tips

- Each tire should be checked monthly when the temperature of the tires is about the same as ambient air temperature and set to the

recommended inflation pressure as specified on the tire pressure label ⇒ *page 280*.



- The tire pressure monitoring system helps the driver to keep an eye on tire pressures. But the driver still has the responsibility for maintaining the correct tire pressure.
- Tire pressure must only be adjusted when the temperature of the tires is about the same as ambient air temperature.
- When tires are replaced, the sensors and valves should not be exchanged. The valve core needs to be replaced. If necessary, the valve and the wheel electronics have to be replaced.
- If the sensor has been removed, then a visual inspection is necessary to check for damage (valve connection not allowed to be disturbed). Take care when installing the sensor in a new wheel. The valve core, nut, valve sealing and seal washer (replacement kit) needs to be replaced. Use the utmost care when replacing parts. The parts to the sensor (e.g. the valve connection, among other things) may not be bent or twisted.
- If you should put different wheels and tires on your vehicle (e.g. winter wheels and tires), you must be certain that the wheels and tires are compatible with the tire pressure monitoring system. Otherwise the system will register a malfunction and a fault message will be displayed. For more information, contact an authorized Audi dealer.
- Adjust the tire pressure and store the pressure in the tire pressure monitoring system to the load you are carrying. ■

Significant loss of air pressure


The yellow symbol appears in the event of a significant loss of air pressure.





Fig. 28 Display: yellow symbol with message

If the  warning light in the instrument cluster comes on and then the  symbol appears in the display \Rightarrow fig. 28, pressure in at least one tire is too low.

- Stop driving as soon as possible without endangering yourself and other drivers on the road.
- Inspect all tires.
- Change the tire if necessary \Rightarrow page 304.

The  warning light in the instrument cluster comes on when the tire is significantly underinflated.

In addition, the tire symbol  appears in the display together with the message **Please check tyre pressure** \Rightarrow fig. 28.

After a few seconds, the message disappears again. If you would like to show the message again, press the Set/Check button \Rightarrow page 12, fig. 2 .

Tips

- In the case of an intentional loss of air pressure, for example, when re-adjusting tire pressure, this has to be stored again afterwards \Rightarrow page 42.
- Tire pressure must only be adjusted when the temperature of the tires is about the same as ambient air temperature.
- The yellow symbol disappears, when the tire pressure is corrected and the new pressure is stored in the system \Rightarrow page 42.
- After changing a wheel or replacing a wheel with the spare tire you have to adjust the tire pressures on all wheels. In addition, you must then initialize the new tire pressures in the tire pressure monitoring system \Rightarrow page 43. ■

Storing tire pressures

Correct storage of specified pressure is the basic requirement for reliable tire pressure monitoring.

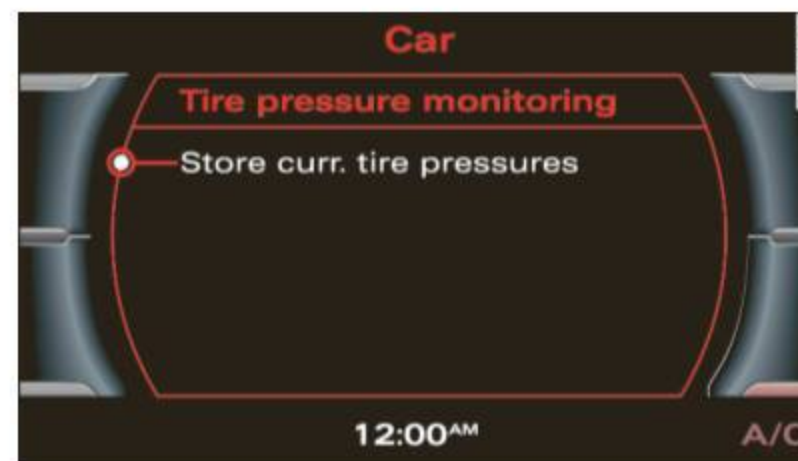


Fig. 29 Tire pressure monitoring system

In order for the tire pressure monitoring system to operate appropriately, you have to re-save the specified pressures whenever you adjust tire pressures, for example when the load condition of your vehicle changes. Proceed as follows: ►

Correcting tire pressure

- Check the pressure in the tires.
- Adjust air pressure as needed to comply with the information on the label located on the driver's side B-pillar (visible when the door is open).

Saving tire pressures

- Turn on the ignition.
- Press the **CAR** function button (when the car is not in motion).
- Select **Tire pressure monitoring**. The menu appears.
- Select **Store curr. tire pressures** ⇒ *page 42, fig. 29*.

All pressure warning indicators in the display will be canceled.

Following each intentional change in specified pressures, tire pressures must be resaved.

After the pressures are saved, the tire pressure monitoring system measures the current tire pressures and saves them as the new specified pressures.

Tips

- The tire pressure is shown on the tire pressure label. The tire pressure label is located on the driver's side B-pillar (visible when the door is open). The tire pressure label lists the recommended cold tire inflation pressures for the vehicle at its maximum capacity weight and the tires that were on your vehicle at the time it was manufactured. For recommended tire pressures for normal load conditions, please see chapter ⇒ *page 280*.
- The tire pressure monitoring system helps the driver to keep an eye on tire pressures. But the driver still has the responsibility for maintaining the correct tire pressure. ■

Wheel change

If a wheel is changed, the wheels that were exchanged have to be reprogrammed.

- Turn on the ignition.
- Press the **CAR** function button (when the car is not in motion).
- Select **Tire pressure monitoring**. The menu appears.
- Select **Store curr. tire pressures** ⇒ *page 42, fig. 29*.

Programming is necessary:

- after the tires have been rotated on the vehicle, or the spare tire is used,
- if tires with new wheel sensors are used.

All pressure warning indicators in the display will be canceled. The system malfunction error message will not disappear until the vehicle is underway. With pressing the button ⇒ *page 42, fig. 29*, the re-programming of the new sensors and storing of actual pressures starts. This learning phase can take up to 10 minutes driving time.

During the learning process the tire pressure monitoring system is not available. ■

Malfunctions TPMS

A malfunction can have various causes.

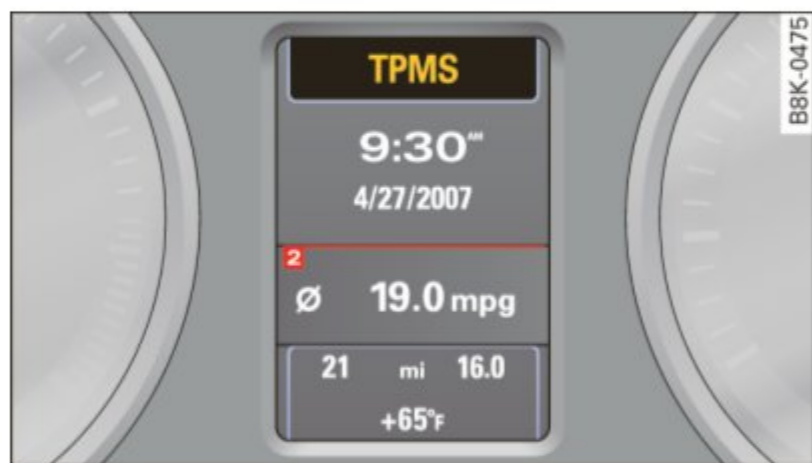



Fig. 30 Display:
System malfunction

If the  warning light in the instrument cluster flashes for approximately one minute and then remains continuously illuminated and additionally the TPMS \Rightarrow fig. 30 symbol appears in the display, the tire pressure monitoring system is not available. This can have various causes.

- If the message appears at the end of the learning process, the system cannot recognize the wheels installed on the vehicle. This can be because one or more wheels without a wheel sensor were installed.
- A wheel sensor or other component may have failed.
- During initialization the system has detected more than 4 wheels on the vehicle, for example while driving next to another car with a tire pressure monitoring system.
- The steps \Rightarrow page 43 had not been carried out yet after a tire change.
- Audi replacement parts were not used.
- If snow chains are being used, system function can be compromised due to the shielding properties of the chains.
- The tire pressure monitoring system may not be available because of a radio malfunction.


- Transmitters with the same frequency, such as radio headphones in the vehicle or radio equipment, can cause a temporary disruption of the system through excessive electromagnetic fields.
- Eliminate the interference if possible/if you can and then proceed as follows: Turn off the engine for 20 minutes. Then drive another 10 min. If the warning light comes on again, you should contact your authorized Audi dealer immediately to have the problem corrected.
- Do not use commercially available tire sealants. Otherwise, the electrical components of the tire pressure monitoring system will no longer work properly and the sensor for the tire pressure monitoring system will have to be replaced by a qualified workshop.

Try to fix the possible causes for the problem, and after letting it sit for 20 minutes, re-start the \Rightarrow page 43 process. If this malfunction occurs again, contact an authorized Audi dealer or other qualified workshop. ■

Certification

This device complies with part 15 of the FCC rules and RSS-210. Operation is subject to the following conditions:

- this device may not cause harmful interference, and
- this device must accept interference received, including interference that may cause undesired operation.

The receiver 5WK49069 uses the same schematic, assembly, layout and PCB as 5WK49097. 5WK49097 is a multi channel receiver and 5WK49069 is a single channel receiver. They only differ in: SAW-Filter V1_4 was changed from A2C00038979 to V1_2 A2C00032378, Inductor L5_3 and L6_233nH were changed to L5_2 and L6_247nH. BAND PASS FILTER V3_2 was changed from A2C00038762 to V3_3 A2C00036085. V10: ATIC75 C1, A2C000029505 was changed to V10: ATIC75 C2-Light, A2C000043220. Q1 14.246MHz A2C00037710 was changed to Q1 15.27MHz A2C00041280. The BAND PASS FILTER V2 is not populated. 

These modifications were necessary to optimize the characteristic of the receiver.

Proof is shown with test report T30739-00-00KJ issued by Mikes-Testingpartners GmbH, Ohmstraße 2-4, 94342 Strasskirchen that the receiver is below the limit. ■

Opening and closing

Keys

Key set



Fig. 31 Key set

A Master key with remote control

You can centrally lock and unlock your vehicle and start the engine with the master key with remote control.

B Emergency key

The emergency key is not intended for constant use. It should only be used in an emergency. Keep it in a safe place and do not carry it on your key ring.

Key replacement

If you lose a key, contact your authorized Audi dealer immediately to have the *lost* key disabled. Be sure to bring all your keys with you.

Personal comfort settings

If two people use one vehicle, it is recommended that each person always uses "their own" master key. When the ignition is turned off or when the vehicle is locked, personal convenience settings for the following systems are stored and assigned to the remote master key.

- Climate control
- Central locking system
- Ambient lighting
- Windows
- Audi parking system*
- Seat memory*

The stored settings are automatically recalled when you unlock the vehicle, when you open the doors or when you turn on the ignition.

WARNING

- **Do not leave your vehicle unattended with the key in the ignition lock. Entry by unauthorized persons could endanger you or result in theft or damage the vehicle. Always lock all doors and take the key.**
- **Do not leave children unattended in the vehicle, especially with access to vehicle keys. Unguarded access to the keys provides children the opportunity to start the engine and/or activate vehicle systems such as the power windows etc. Unsupervised operation of any vehicle system by children can result in serious injury.**
- **Do not remove the key from the ignition lock until the vehicle has come to a complete stop. Otherwise the steering column lock could suddenly engage - causing the risk of an accident.**

Tips

- The operation of the remote control key can be temporarily disrupted by interference from transmitters in the vicinity of the vehicle working in the same frequency range (e.g. a cell phone, radio equipment).

- If you open the driver's door with the key left in the ignition lock, a chime will sound. This is your reminder to remove the key and lock the door.
- For security reasons, replacement keys are only available from Audi dealers. ■


Check light in the master key

The check light in the master key provides information about different conditions.



Fig. 32 Check light in the master key

The check light comes on briefly once when a button is pressed, and during an "inquiry" by the advanced key system.

If the check light does not come on, the battery is dead and has to be replaced. In addition, when the battery is dead the  symbol appears in the instrument cluster display as well as the message:

Please change key battery

Battery replacement ⇒ page 47. ■

Master key battery replacement

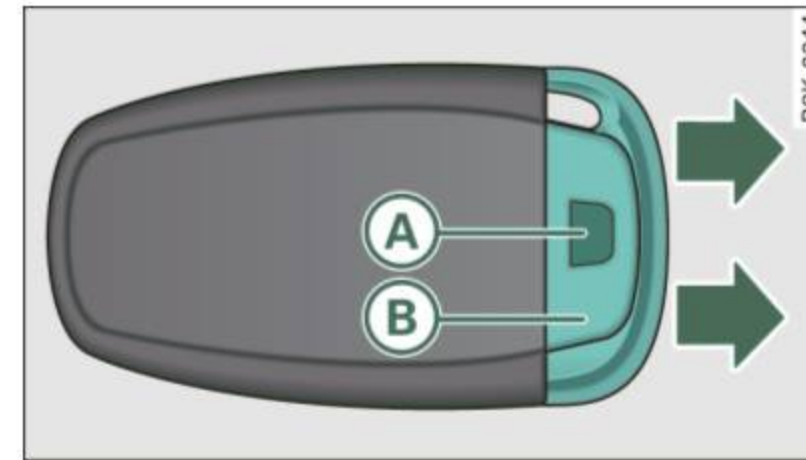


Fig. 33 Remote master key: Removing the mechanical key

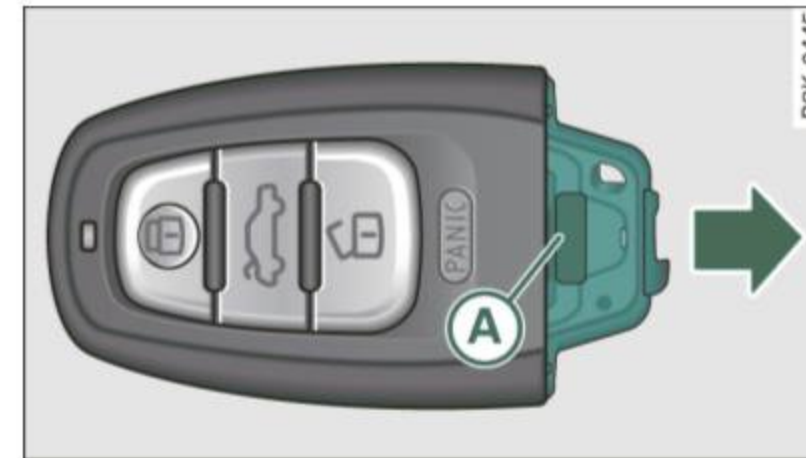


Fig. 34 Remote master key: Removing the battery holder

We recommend having the battery changed by an authorized Audi dealer. However, if you wish to replace the dead battery yourself, proceed as follows:

- Press the release button (A) ⇒ fig. 33.
- Pull the mechanical key (B) out of the master key.
- Press the release button (A) ⇒ fig. 34 on the battery holder and at the same time pull the battery holder out of the master key in the direction of the arrow.
- Install the new battery CR 2032 with the "+" sign facing down.

- Push the battery holder carefully into the master key.
- Install the mechanical key.

For the sake of the environment

Dispose of dead batteries properly so as not to pollute the environment.

Tips

The replacement battery must be the same specification as the original. ■

Removing the mechanical key

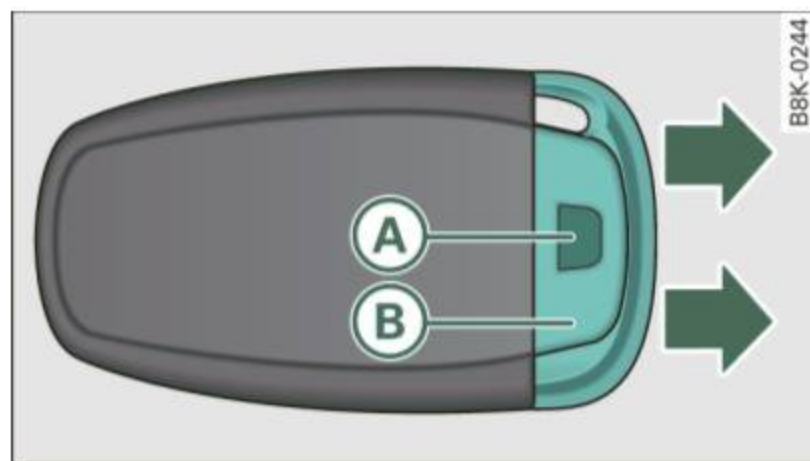


Fig. 35 Remote master key: Removing the mechanical key

- Press the release button **A** ⇒ fig. 35.
- Pull the mechanical key **B** out of the master key.

Using the mechanical key, you can

- Lock and unlock* the storage compartment on the passenger's side ⇒ *page 97*.
- Lock and unlock the lockable rear seat ⇒ *page 90*.

- Lock and unlock the vehicle manually ⇒ *page 53* if this should not be possible with the master key. ■

Emergency unlocking of the ignition key

In the event of malfunctions in the electrical system, it may happen that you cannot remove the ignition key.

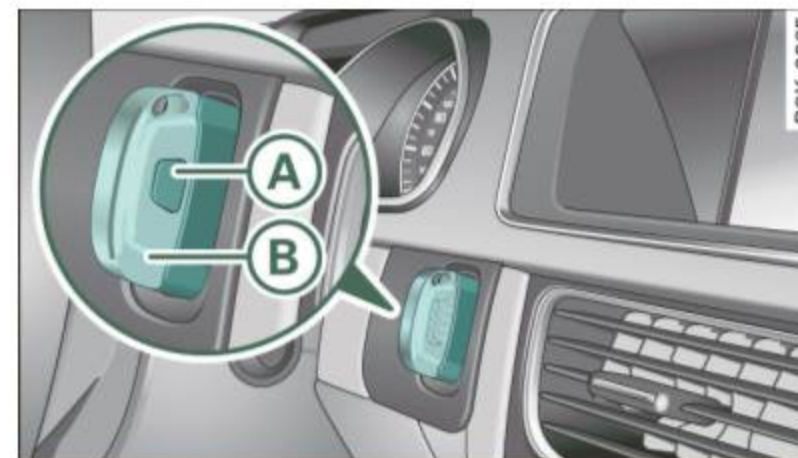


Fig. 36 Ignition switch with ignition key

If you are unable to remove the ignition key, for example because the vehicle battery is discharged, proceed as follows:

- Press the release button **A** ⇒ fig. 36 for example with a ball point pen and pull the mechanical key **B** out of the master key.
- Lock the vehicle using the mechanical key ⇒ *page 53*.
- Have the electrical system inspected by an authorized Audi dealership. ■

Starting the vehicle with the emergency key

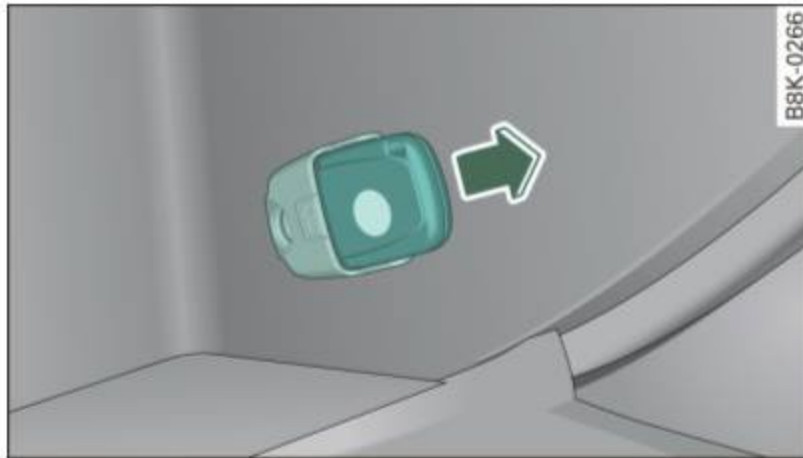


Fig. 37 Glove compartment: Adapter for emergency key

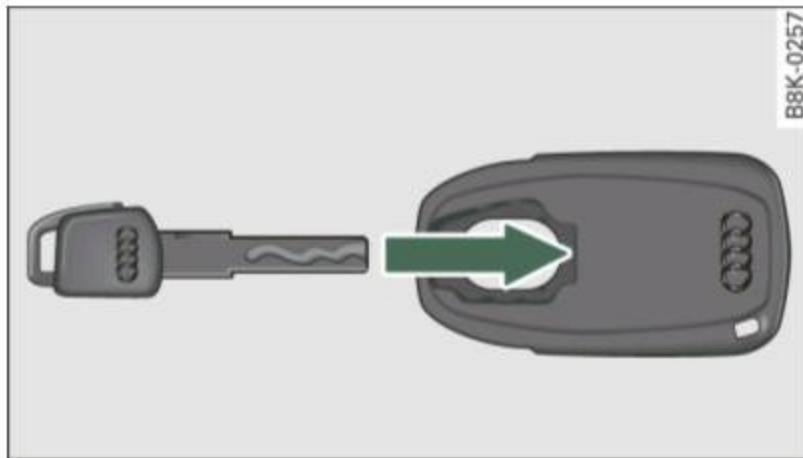


Fig. 38 Insert emergency key into the adapter

- Take the adapter for the emergency key out of the glove box ⇒ fig. 37.
- Push the emergency key ⇒ fig. 38 fully into the adapter. Make sure that the Audi rings are facing up.
- Press the emergency key in the adapter down until it latches audibly.
- Insert the adapter with the emergency key forward into the ignition switch. The engine can now be started as usual. ■

Electronic immobilizer

The immobilizer prevents your vehicle from being started by unauthorized persons.

Inside the key there is a computer chip. This chip automatically deactivates the electronic immobilizer when you insert the key in the ignition lock. When you remove the key from the ignition lock, the electronic immobilizer is automatically activated once again.

If an unauthorized key was used, **SAFE** is displayed continuously in the odometer display field.



Tips

- Your engine can only be started using the factory-equipped key.
- You may not be able to start your vehicle if an ignition key of a different vehicle make is also located on your set of keys. ■

Power locking system

General description

The power locking system locks or unlocks all doors and the rear lid simultaneously.

You can lock and unlock the vehicle centrally. You have the following choices:

- Remote master key ⇒ page 51
- Door handles with advanced key* ⇒ page 52,
- Lock cylinder at the driver's door ⇒ page 53, or
- Power window switch inside ⇒ page 54.

Selective unlocking

When they are closed, the door and rear lid are locked. When unlocking, you can set in the radio or in the MMI* whether *only* the driver's door or the entire vehicle should be unlocked ⇒ *page 51*.

Automatic locking

The automatic locking feature locks all the vehicle doors and the rear lid when you drive faster than 9 mph (15 km/h).

The car is unlocked again once the ignition key is removed. In addition, the vehicle can be unlocked if the opening function in the power locking system switch or at one of the door levers is actuated. The Auto Lock function can be turned on and off in the radio or in the MMI* ⇒ *page 51*.

Additionally, in the event of a crash with airbag deployment the doors are automatically unlocked to allow access to the vehicle.

Anti-theft alarm warning system

If the anti-theft alarm warning system detects a break-in into the vehicle, acoustic and visual warning signals are triggered.

The anti-theft warning system is activated automatically when you lock the vehicle. It is deactivated when unlocking using the **remote key**, with the **mechanical key**, and when you switch on the ignition.

The alarm also turns off when the alarm cycle has expired.

Turn signals

When you unlock the vehicle, the turn signals flash twice, when you lock it once. If they do not flash, one of the doors, the rear lid or the hood is not locked.

Unintentionally locking yourself out

In the following cases there are safeguards to prevent you locking your remote master key in the vehicle:

- If a door is open, the vehicle cannot be locked using the central locking system switch ⇒ *page 54*.

- On vehicles with advanced key*, if the most recently used master key is in the luggage compartment, the rear lid is automatically unlocked again after it is closed ⇒ *page 55*.

Do not lock your vehicle with the **remote master key** until all doors and the rear lid are closed. In this way you avoid locking yourself out accidentally.



WARNING

- **When you leave the vehicle, always remove the ignition key and take it with you. This will prevent passengers (children, for example) from accidentally being locked in the vehicle should they accidentally press the power locking switch in the front doors.**
- **Do not leave children inside the vehicle unsupervised. In an emergency it would be impossible to open the doors from the outside without the key.**



Tips

- In the event of a crash with airbag deployment all locked doors will be automatically unlocked to give access to the vehicle occupants from the outside.
- If the power locking system should malfunction, you can lock the driver's door using the mechanical key ⇒ *page 55*.
- If the power locking system should fail, you can still open the fuel tank flap in an emergency ⇒ *page 257*.
- You are well advised not to keep valuables inside an unattended vehicle, visible or not. Even a properly locked vehicle cannot provide the security of a safe.
- If the LED in the upper edge of the driver's door panel comes on for about 30 seconds after the vehicle is locked, there is a malfunction in the power locking or the anti-theft warning system. Have the malfunction corrected by an authorized Audi dealership or qualified repair facility. ■

Setting power locking

The driver can determine the functions for power locking in the radio or in the MMI*.



Fig. 39 MMI display: Central locking menu


In the **Central locking** menu you can decide which doors should be unlocked with the remote key, and/or the advanced key* when opening the vehicle.

- Press the **CAR** function button.
- Select **Central locking**. The **Central locking** menu appears ⇒ fig. 39.

For example, if you switch the item “Single door unlocking” **on**, the passenger's door is no longer included in the power locking system, and will not be unlocked by pressing the unlock button on the master key remote control.

You can continue to unlock all the doors and the rear lid as before. Press the opening button on the master key twice.

When locking the vehicle, all doors and the trunk lid are locked automatically.

If you switch “Trunk lid” **off**, opening the rear lid at the handle ⇒ page 55, fig. 47 is blocked. In this case the rear lid can be opened with the button  on the master key ⇒ fig. 40 or with the unlocking button in the driver's door ⇒ page 55, fig. 46. ■

Unlocking and locking the vehicle with the remote control

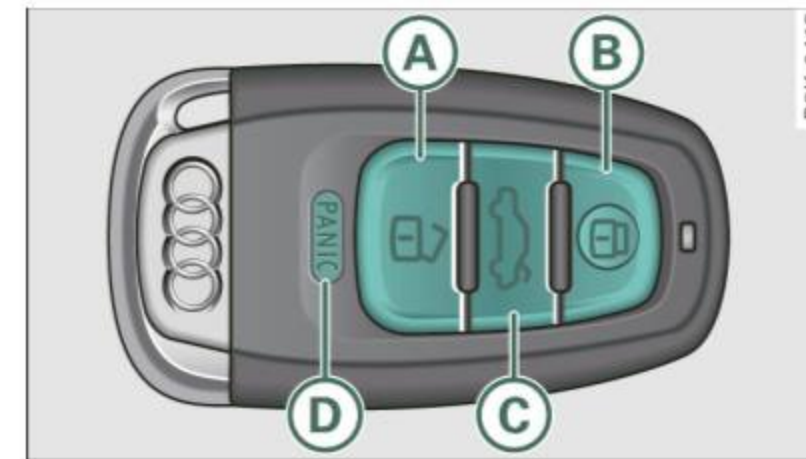







Fig. 40 Remote control: function buttons

Either the driver's door only or the entire vehicle will unlock when the unlock button **(A)** is pressed once, depending on the settings in the MMI **Central locking** menu ⇒ page 51.

- Press button  (**A**) to unlock the vehicle ⇒ fig. 40.
- Press button  (**B**) to lock the vehicle ⇒  in “General description” on page 49.
- Press button  (**C**) briefly to unlock the rear lid.
- Press the button  for at least one second to open the rear lid.
- Push the red **PANIC** button (**D**) to activate the panic function. The horn sounds and the turn signals flash. Push the red **PANIC** button again to deactivate the panic function.

If the vehicle is unlocked and no door, the rear lid or the hood is opened within 60 seconds, the vehicle locks itself again automatically. This feature prevents the vehicle from being accidentally left unlocked over a long period of time. ►


It depends on the settings in the radio or in the MMI* whether the entire vehicle is unlocked or only certain doors ⇒ *page 51*.

On vehicles with advanced key*, the selector lever must be in the P position, otherwise the vehicle cannot be locked.

WARNING

Read and follow all WARNINGS ⇒  in "General description" on *page 49*.

Tips

- In order to make sure the locking function is working, you should always keep your eye on the vehicle to make sure it is properly locked.
- Do not use the remote control if you are inside the car, otherwise you may unintentionally lock the vehicle, and then you would set off the anti-theft alarm when you try to start the engine or open a door. In case this happens anyhow, push the unlock button .
- Use the panic function only if you are in an emergency situation. ■

Applies to vehicles: with advanced key

Locking and unlocking with advanced key

The doors and the rear lid can be unlocked and locked without operating the master key.

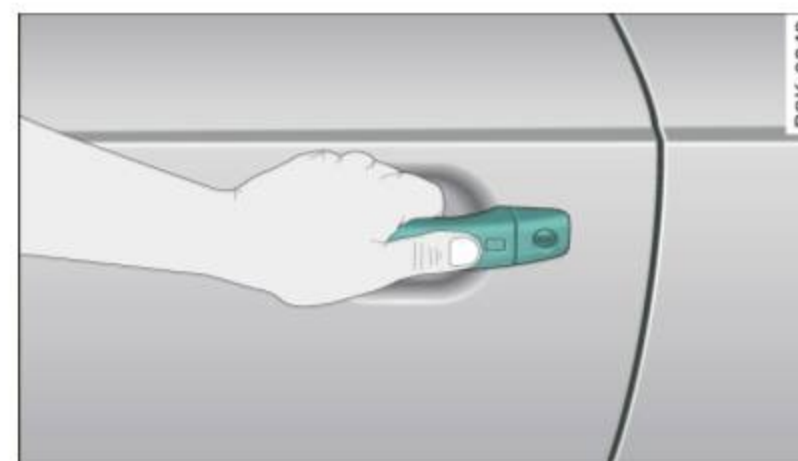


Fig. 41 Advanced key:
Unlocking vehicle door



Fig. 42 Advanced key:
Locking the vehicle

Unlocking vehicle

- Take hold of the door handle. The door is unlocked automatically.
- Pull the handle to open the door.

Locking vehicle

- Move the selector lever to the P position (automatic transmission), otherwise the vehicle cannot be locked. ►

- Touch the sensor at the door handle **once** ⇒ *page 52*, fig. 42 to lock the vehicle ⇒ ⚠ in “General description” on *page 49*.

The vehicle can be locked and unlocked at any door. It depends on the settings in the radio or in the MMI* whether the entire vehicle is unlocked or one of the doors ⇒ *page 51*. The master key must be within a range of about 1.5 m from the appropriate door or the rear lid. It makes no difference whether the master key is in your jacket pocket or in your brief case.

If the area of the sensor in the door handle is touched while unlocking ⇒ *page 52*, fig. 42, this may adversely affect the opening function.

If you grip the door handle while locking, this can adversely affect the locking function.

It is not possible to re-open the door for a brief period directly after closing it. This allows you to ensure that the doors are properly locked.

⚠ WARNING

Read and follow all WARNINGS ⇒ ⚠ in “General description” on *page 49*.

i Tips

If your vehicle has been standing for an extended period, please note the following:

- The proximity sensors are deactivated after a few days to save power. You then have to pull on the door handle once to unlock the vehicle and a second time to open the vehicle.
- To prevent the battery from being discharged and to preserve your vehicle's ability to start for as long as possible, the energy management system gradually switches off unnecessary convenience functions.

It is possible that you will not be able to unlock your vehicle using these convenience functions. ■

Operating locks with the mechanical key

In the event of a failure of the power locking system, the driver's door can be locked and unlocked with the mechanical key at the lock cylinder.

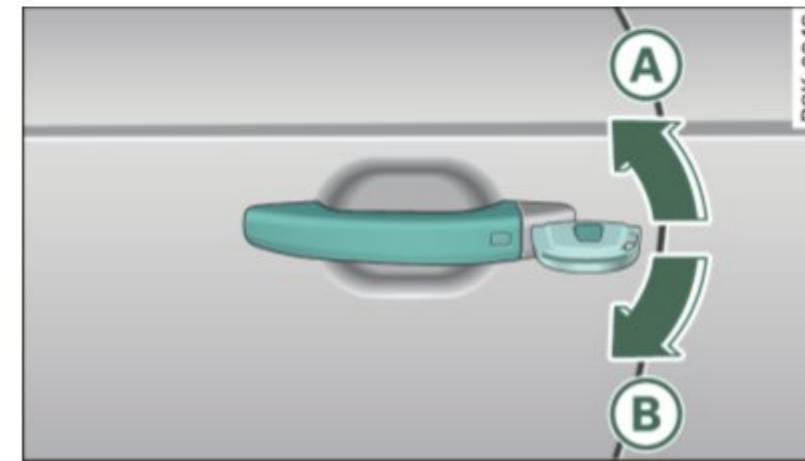


Fig. 43 Key turns for opening and closing

To unlock the vehicle

- Insert the mechanical key into the lock of the driver's door.
- Turn the mechanical key to position **A** ⇒ fig. 43.

To lock the vehicle


- Move the selector lever to the P position (automatic transmission).
- Close all windows and doors properly.
- Turn the mechanical key in the lock of the driver's door to the lock position **B** ⇒ ⚠ in “General description” on *page 49*.

If the power locking system fails, there is emergency locking for the passenger's door ⇒ *page 55*.

WARNING

Read and follow all WARNINGS ⇒  in "General description" on *page 49*.




Tips

- After the ignition is switched on, the power locking system switch and the unlocking button for the rear lid  in the door are enabled. ■

Locking and unlocking the vehicle from inside



Fig. 44 Drive's door: power locking switch

- Press the button  to unlock the vehicle ⇒ fig. 44.
- Press the button  to lock the vehicle ⇒ .

If you lock the vehicle using the **power locking switch**, please note the following:

- If a door is open, the vehicle cannot be locked using the power locking system switch.

- You cannot open the doors or the rear lid from the *outside* (increased security, for example when you are stopped at a red light).
- The diodes in the power locking switch illuminate when all the doors are closed and locked.
- You can unlock and open the doors from the inside by pulling on the door handle.
- If you have a crash and the airbag is activated, the doors automatically unlock.

WARNING

- The power locking switch works with the ignition off and automatically locks the entire vehicle when it is actuated.
- On a vehicle locked from the outside the power locking system switch is inoperative.
- Locking doors from the inside can help prevent inadvertent door opening during an accident and can also prevent unwanted entry from the outside. Locked doors can, however, delay assistance to vehicle occupants and hold up rescue efforts from the outside in an accident or other emergency.

Tips

Your vehicle is locked automatically at a speed of 9 mph (15 km/h) (Auto Lock) ⇒ *page 49*. You can unlock the vehicle again using the opening function in the power locking system switch. ■

Emergency locking of the passenger's door

If the power locking system fails (power failure), you will need to lock the passenger door separately.

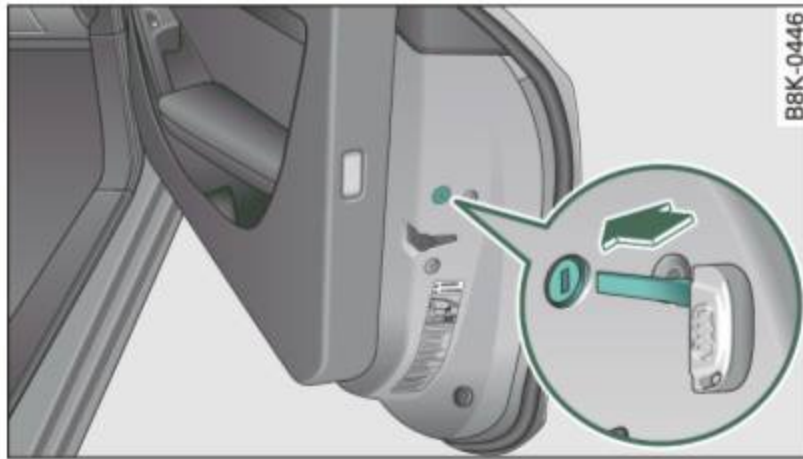


Fig. 45 Emergency locking of the passenger's door

An emergency locking mechanism is integrated in the edge of the passenger's door (only visible when the door is open).

- Take the mechanical key out of the master key ⇒ *page 48*.
- Open the door.
- Pull the protective cover out of the hole ⇒ *fig. 45*.
- Insert the mechanical key into the inner slot and turn it to the right as far as it can go.

After you close the door, you will no longer be able to open it from the outside. The door can be opened from the inside by pulling once on the door handle. ■

Opening and closing rear lid/trunk lid





Fig. 46 Driver's door: remote rear lid release



Fig. 47 Position of handle in the rear lid

Opening the rear lid

- Press the middle button  on the remote control master key for at least one second, or
- Pull the release button  in the driver's door ⇒ *fig. 46*. The rear lid unlocks and opens, or
- Press the handle on the rear lid ⇒ *fig. 47*.


Closing the rear lid

- Pull the rear lid down at the grip on the inside and allow it to drop gently to close it ⇒ .

WARNING

- After closing the rear lid, always pull up on it to make sure that it is properly closed. Otherwise it could open suddenly when the vehicle is moving.
- To help prevent poisonous exhaust gas from being drawn into the vehicle, always keep the rear lid closed while driving. Never transport objects larger than those which fit completely into the luggage area, because then the rear lid cannot be fully closed.
- Never leave your vehicle unattended especially with the rear lid left open. A child could crawl into the car through the luggage compartment and pull the lid shut, becoming trapped and unable to get out. To reduce the risk of personal injury, never let children play in or around your vehicle. Always keep the rear lid as well as the vehicle doors closed when not in use.
- Always ensure that no one is within range of the rear lid when it is moving, in particular close to the hinges - fingers or hands can be pinched.

Tips

- When the vehicle is locked, the rear lid can be opened separately by pressing the button  on the master key. When you close the rear lid again, it locks automatically.
- If the rear lid is open or not properly closed when the ignition is turned on, the door and rear lid warning \Rightarrow page 25 appears in the instrument cluster display. ■

Power windows

Controls

The driver can operate the window regulator for the driver's door with the left switch and the window regulator for the passenger's door with the right switch.

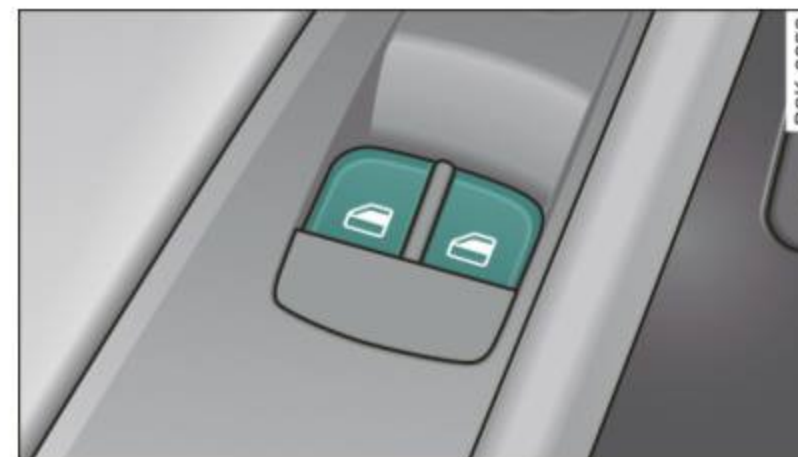



Fig. 48 Driver's door: power window switches

If the respective switch is pushed or pulled the window will open or close. The power window switches have a **two-position function**:

Opening the windows

- Push the switch to the **first stop** and hold it there until the window has lowered to the desired position.
- Push the switch briefly to the **second stop**: the window will automatically open all the way.

Closing the windows

- Pull the switch up to the **first stop** and hold it there until the window has risen to the desired position.
- Pull the switch quickly to the **second position**: the window will automatically close all the way. 

WARNING

- Do not leave children unattended in the vehicle, especially with access to vehicle keys. Unsupervised use of the keys can result in starting of the engine and use of vehicle systems such as power windows, etc. which could result in serious injury.
- Remember – you can still open or close the power windows for about ten minutes after the ignition is switched off. Only when either of the doors are opened are the power windows switched off.
- Be careful when closing the windows. Check to see that no one is in the way, or serious injury could result!
- Always remove the ignition key whenever you leave your vehicle.
- If you lock your vehicle from the outside, no one, especially children, should remain in the vehicle.
- Do not stick anything on the windows or the windshield that may interfere with the driver's field of vision.

Tips

- When you open the doors, the windows automatically lower about 10 mm.
- After the ignition has been switched off, the windows can still be opened or closed for about 10 minutes. The window regulators are not switched until the driver's or passenger's door is opened. ■

Convenience opening/closing

The windows and the panorama roof can be opened and closed with the mechanical key or the emergency key.

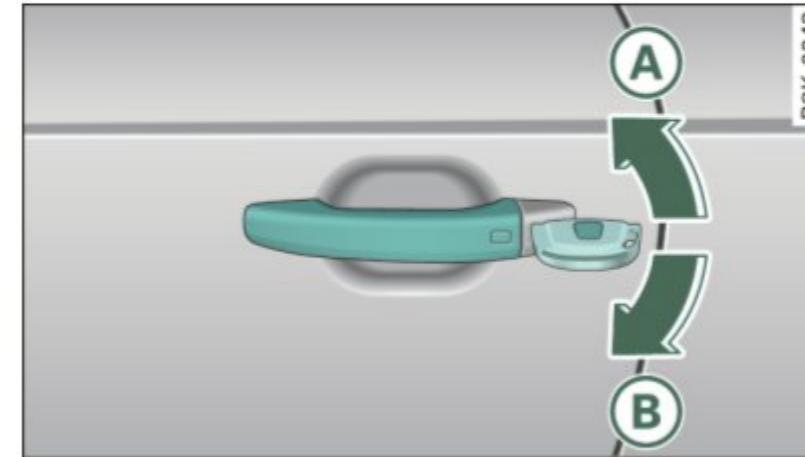



Fig. 49 Key turns for opening and closing

Convenience opening feature


- Use the emergency key or pull the mechanical key out of the master key ⇒ *page 48*.
- Insert the key into the lock of the driver's door.
- Turn the key to position ⇒ fig. 49 **A** until all the windows have reached the desired position and the panorama roof is tilted.

Convenience closing feature

- Use the emergency key or pull the mechanical key out of the master key ⇒ *page 48*.
- Turn the key in the lock of the driver's door to the lock position **B** until the windows and the panorama roof are closed ⇒ .

When the panorama roof is tilted/closed, the electric sun shade* is also opened/closed. ►

WARNING

- Never close the windows and the panorama roof inattentively and without checking - there is risk of injury.
- You must always watch when the windows are being raised so that no one can be trapped. If you release the key, the closing action is immediately canceled.
- Always read and heed WARNING ⇒  in "General description" on page 49. ■

Correcting window regulator malfunction

After disconnecting the vehicle battery, the one-touch up and down feature must be activated again.

- Pull and hold the power window switch until the window is completely closed.
- Release the switch.
- Pull the switch again for one second. The automatic closing/opening is now reactivated. ■

Valet parking

Through the "valet parking" feature the luggage compartment of your vehicle is secured from unauthorized access during the valet parking service.

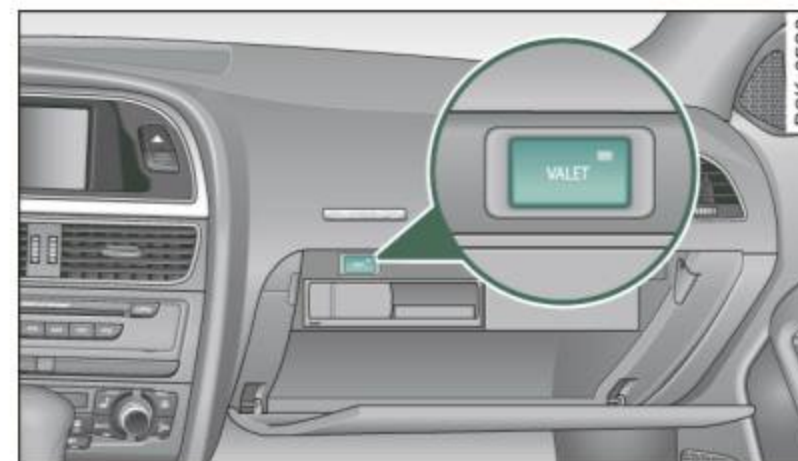




Fig. 50 Valet parking button

With "valet parking" activated, the rear lid cannot be opened.

- Take the mechanical key out of the master key ⇒ page 48.
- Open the glove box ⇒ page 97 and activate ⇒ fig. 50 the "valet parking" feature by pressing the **VALET** button. The indicator light in the switch illuminates.
- Close the glove box and lock it with the mechanical key.
- Lock both rear seat backs with the mechanical key ⇒ page 90.
- Lock the luggage compartment pass-through with the mechanical key ⇒ page 91.
- Leave the master key with the service personnel for parking and keep the mechanical key with you.

When the "valet parking" feature is activated: 

- the unlocking button for the rear lid  in the driver's door is inactive
- the button  on the master key is inactive
- the opening handle in the rear lid is inactive.

The vehicle can be driven and locked and unlocked with the master key. Access to the luggage compartment is blocked. ■

Panorama roof

Tilting and closing



Fig. 51 Section from headliner: Switch for panorama roof

- To tilt the panorama roof, press the switch briefly.
- To close the panorama roof, pull the switch briefly.
- To set an intermediate position, press/pull the switch until the roof reaches the desired position.

After the ignition is switched off, you can still operate the Panorama for about 10 minutes. As soon as the driver's or passenger's door is opened, the switch is inoperative.

Sun blind

The sun blind can be opened and closed manually in any position.

WARNING

Pay careful attention when closing the panorama roof - otherwise serious injury could result! For this reason, always remove the ignition key when leaving the vehicle.

- Never leave children or persons requiring assistance alone in the vehicle, especially when they could access the vehicle keys. Unsupervised use of the keys can result in the engine being started or use of vehicle systems such as the power windows, etc. which could result in serious injury. The doors could be locked with the remote key, delaying help in an emergency.
- The panorama roof will continue to operate until the ignition key has been removed and one of the front doors has been opened.

Note

Always close your panorama roof when leaving your vehicle. Sudden rain can cause damage to the interior equipment of your vehicle, particularly the electronic equipment.

Tips

- If the tilted roof cannot be closed, pull the switch within 5 seconds after the automatic opening until the roof is closed.
- Information on convenience opening/closing ⇒ *page 57*. ■

Emergency closing of the panorama roof

The panorama roof can be closed manually in an emergency.



Fig. 52 Section from headliner: Unscrewing lighting unit

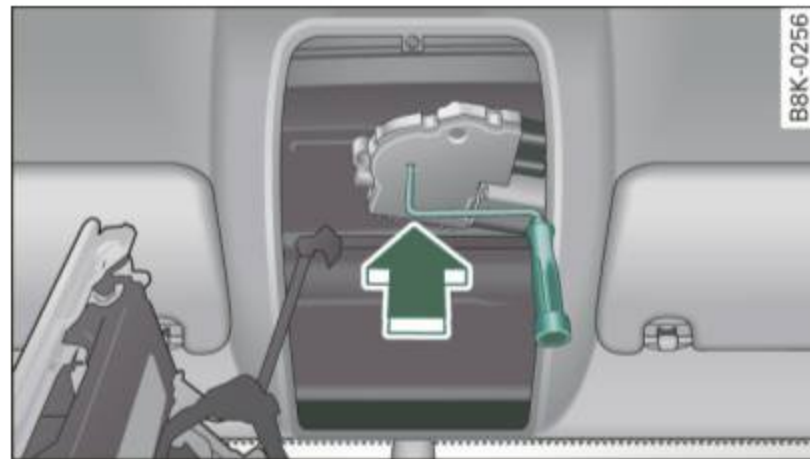


Fig. 53 Section from headliner: Crank for emergency operation

You will find the screwdriver in the vehicle tool kit
 ⇒ page 298 and the crank in the fuse cover ⇒ page 312,
 fig. 228.

- Remove the screw ⇒ fig. 52 -Arrow- from the lighting unit and pull the lighting unit out carefully.
- Push the crank into the hexagonal hole as far as it will go ⇒ fig. 53 and turn it. The roof will close.

Tips

The crank is easier to turn if you use the screwdriver handle (vehicle too kit) as an aid. ■

Clear vision

Lights

Switching the lights on and off




Fig. 54 Instrument panel: Headlight control switch

Switching on AUTO - Automatic headlight controls*

- Turn the light switch to **AUTO** ⇒ fig. 54.

Turning on the parking light

- Turn the head light control switch to .

Switching on low beams

- Turn the headlight control switch to .


Switching off the lights

- Turn the headlight control switch to **O**.

The low beams only illuminate with the ignition turned on.

With the parking lights or headlights switched on, the symbol next to the light switch illuminates .

AUTO - Automatic headlight control*

With the switch in the **AUTO** position, the low beams are switched on automatically depending on the ambient light, for example in a tunnel, at dusk and when it is raining or snowing. When the low beams are switched on, the  symbol comes on. The low beams remain switched on regardless of the ambient light when you turn on the fog lights.

When you turn off the ignition, the low beams are automatically switched off.


On vehicles with a rain sensor the headlights switch on automatically after a few windshield wiper passes. However, the instrument lighting will not be switched on.

With automatic headlight control, you also have the high-beam function available. However, if you have not switched high beams back to low beams while driving with automatic headlight control, only the low beams come on the next time you turn on automatic headlight control. In order to return to high beams again, you first have to pull the high beam lever back to the normal position and then push the lever forward.


Light sensor malfunction

In the event of a light sensor malfunction, the driver is notified in the instrument cluster display:

Automatic driving lights/automatic wipers defective

For safety reasons, the low beams are turned on permanently with the switch in **AUTO**. However, you can continue to turn the lights on and off using the light switch. Have the light sensor checked as soon as possible at an authorized Audi dealer or other qualified workshop. 

WARNING

Automatic headlights are only intended to assist the driver. They do not relieve the driver of his responsibility to check the headlights and to turn them on manually according to the current light and visibility conditions. For example, fog cannot be detected by the light sensors. So always switch on the headlights under these weather conditions and when driving in the dark .

Tips

- The light sensor for headlight control is located in the rear view mirror mount. You should therefore not apply any stickers to the windshield in this area in order to prevent malfunctions or failures.
- The sensitivity level for the light sensor set at the factory can be changed in the MMI menu \Rightarrow page 63 in the automatic driving lights function.
- When you remove your key from the ignition while the vehicle's lights are turned on, a buzzer sounds as long as the driver's door is open.
- Please obey all laws when using the lighting systems described here.
- The coming home/leaving home function is available only with the switch in the AUTO position. ■

Fog lights

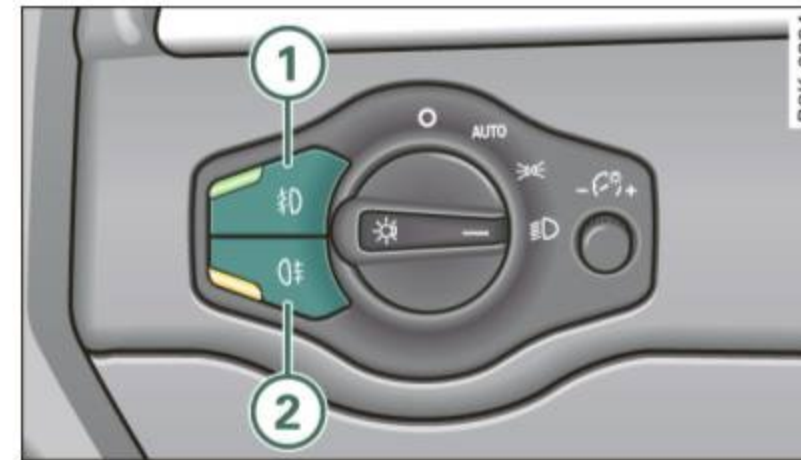




Fig. 55 Fog light switch

- To turn on the fog lights , press button ① \Rightarrow fig. 55.
- To turn on the rear fog lights , press button ②.

Fog lights

The parking lights or low beams must be switched on. When the fog lights are switched on, the green check light at the edge of the switch comes on.

If automatic driving light control AUTO is activated, the low beams are switched on when the fog lights are turned on.

Rear fog lights

Low beams or parking lights with fog lights must be turned on.

When the rear fog lights are turned on, the yellow check light at the edge of the switch comes on.

Note

The rear fog lights should only be turned on in accordance with traffic regulation, as the lights are bright for following traffic. ■

Adjusting exterior lighting

The functions are selected in the radio or in the MMI.



Fig. 56 MMI Display: Exterior lighting

Requirement: The light switch is in the **AUTO** position.

- Select: Function button **CAR** > **Exterior lighting**.

Coming home

The coming home function ensures that after **turning off the ignition and opening the driver's door** the vehicle periphery is illuminated in the dark. In addition, the front fog lights, the tail lights and the license plate light are turned on. The power-on time can be set for a period from 0 (off) to 30 or 60 seconds.

Leaving home

The leaving home functions ensures that **when unlocking**, the vehicle periphery is illuminated in the dark. In addition, the front fog lights, the tail lights and the license plate light are turned on. This function can be turned on and off.

Automatic driving lights*

When the light switch is in the AUTO ⇒ *page 61* position, the switch-on point of the lights can be changed in the automatic driving light function.

Daytime running lights*

The daytime running lights can be turned on or off using this function. If the function is active, the daytime running lights are turned on automatically when the ignition is switched on.

In the versions for some countries it is not possible to switch off the daytime running lights or they may not have daytime running lights.



Tips

The coming home/leaving home function is available only with the switch in the AUTO position. ■

Daytime running lights (DRL) (USA models)

The daytime running lights are turned on automatically when the ignition is switched on.

On vehicles with *xenon lights* the daytime running lights will come on automatically when the ignition is turned on and the light switch ⇒ *page 61*, fig. 54 is in the **O** position or the **AUTO** position (only in daylight conditions). The **Daytime running lights** function can be turned on and off in the MMI menu **Exterior lighting** ⇒ *page 63*. On vehicles with *halogen lights* there is no daytime running lights function.




WARNING

Never use daytime running lights to see where you are going. They are not bright enough and will not let you see far enough ahead for safety, especially at dusk or when it is dark. Be aware of changes in outside light conditions when you are driving and respond by switching on your low beams \equiv D.




Note

Always be aware of changes in outside light conditions while you are driving. Respond in time to fading daylight by turning the light ►

switch to position  (or "AUTO" if your car is equipped with this feature) to turn on your headlights. ■


Daytime running lights (Canada models only)

When you turn on the ignition the daytime running lights will come on automatically.


The daytime running lights are activated **only** when the light switch \Rightarrow page 61, fig. 54 is either at the **O** or the  position. When the ignition is switched on, there is a difference between vehicles with bi-xenon lights and halogen lamps:

- On vehicles with bi-xenon lights only the daytime running lamps in the headlights will come on.
- On vehicles with halogen lights the front fog lights, side marker lights and tail lights come on automatically.

WARNING

Never use daytime running lights to see where you are going. They are not bright enough and will not let you see far enough ahead for safety, especially at dusk or when it is dark. Be aware of changes in outside light conditions when you are driving and respond by switching on your low beams .

Note

- Always be aware of changes in outside light conditions while you are driving. Respond in time to fading daylight by turning the light switch to position  (or "AUTO") to turn on your headlights. ■

Tips

The daytime running lights function cannot be turned off. ■

Instrument lighting

The basic brightness of the illumination for the instruments, the center console and the display can be adjusted.



Fig. 57 Instrument lighting


- Press the knob to release it.
- Rotating the knob to the right "+" will increase the basic brightness when it is dark.
- Rotating the knob to the left "-" will decrease the basic brightness when it is dark.
- Pressing the knob will prevent unintentional changes.

Note

The instrument cluster and center console illumination (gauges and needles) comes on when you switch on the ignition and the **vehicle headlights are off**. Be aware of the following difference between models built to US or Canadian specifications:

- **USA models:** illumination of the instrument cluster (gauges and needles), dash and center console around the gearshift lever is controlled by a light sensor located in the instrument panel. The instrument panel illumination will automatically become dimmer as the daylight fades away and eventually will go out completely ►

when outside light is very low. This is to remind you, the driver, to switch on the headlights before it gets too dark.

- **Canada models:** instrument panel illumination will stay bright regardless of the intensity of ambient light. Always be aware of changes in outside light conditions while you are driving. Respond in time to fading daylight by turning the light switch to position  (or "AUTO" if your car is equipped with this feature) to turn on your headlights. ■

Applies to vehicles: with xenon headlights

Xenon headlights

After starting the engine, the xenon headlights are automatically adjusted to the load and angle of the vehicle (for example, during acceleration and braking). This prevents oncoming traffic from experiencing unnecessary headlight glare from your xenon headlights.

If the system is not operating properly, a warning symbol in the Auto-Check Control is displayed ⇒ *page 39*. ■

Applies to vehicles: with adaptive light

Adaptive light

When driving around bends, the relevant area of the road is better illuminated.

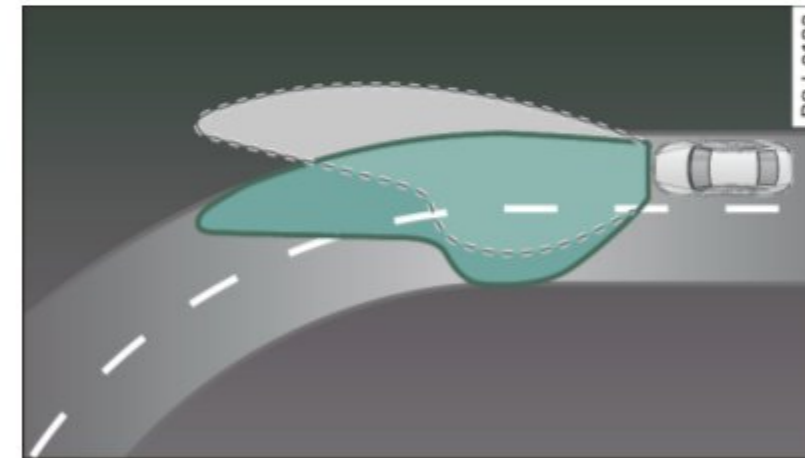


Fig. 58 Adaptive light when driving

The benefit of adaptive light is that the curve and the edge of the road are better illuminated ⇒ fig. 58. Dynamic adaptive light is controlled automatically, depending on vehicle speed and steering wheel angle.

When driving around bends, the headlights are controlled according to steering wheel angle. So that there is no black hole ahead of the vehicle, the two main beams pivot at different angles.



Tips


The system works above a speed of about 6 mph (10 km/h). ■




Emergency flashers

The emergency flashers makes other motorists aware that you or your vehicle are in an emergency situation.



Fig. 59 Emergency flasher switch

- Press the switch  ⇒ fig. 59 to turn the emergency flashers on or off.

When the emergency flashers are on, all four turn signals blink at the same time. The turn signal indicator lights   in the instrument cluster, as well as the light in the emergency flasher switch  blink likewise. The emergency flashers also work when the ignition is turned off.

The emergency flashers will turn on automatically if you are in an accident where the airbag has deployed.

Tips

You should turn on the emergency flashers when:

- you are the last vehicle standing in a traffic jam so that any other vehicles coming can see you, or when
- your vehicle has broken down or you are in an emergency situation, or when
- your vehicle is being towed by a tow truck or if you are towing another vehicle behind you. ■

Turn signals - and high beam lever

The lever on the left side of the steering column is used to operate the turn signals and the high beam as well as the headlight flasher.

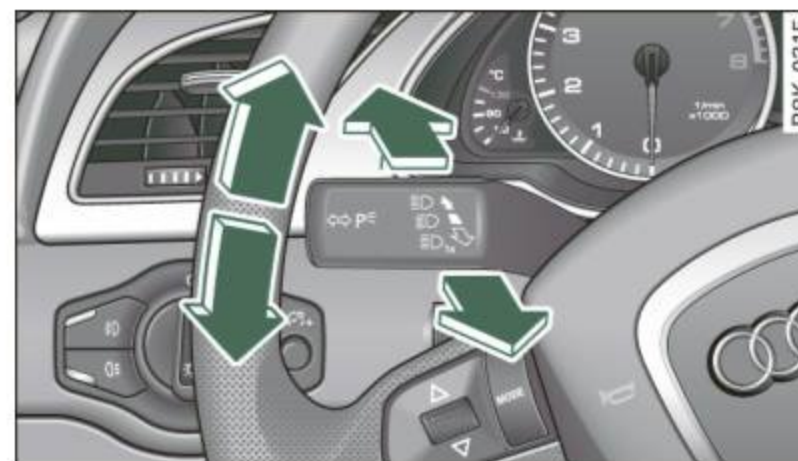


Fig. 60 Turn signal and high beam lever

The turn signal and high beam lever has the following functions:

Turn signals

- Push the lever up as far as it can go to turn on the right turn signal or down to turn on the left turn signal ⇒ fig. 60.
- Move the lever briefly until you meet resistance and release it to flash three times.
- Move the lever (up or down) until you meet resistance and hold it there to determine the flashing time for the turn signals.





High beam

- Push the lever forward to switch on the high beam.
- Pull the lever back towards you to switch off the high beam.

Headlight flasher

- Pull the lever toward the steering wheel to use the headlight flasher.

Notes on these features

- The *turn signals* only work with the ignition turned on. The indicator lights  or  in the instrument cluster also blink.
- After you have turned a corner, the turn signal switches off automatically.
- The *high beam* works only when the headlights are on. The indicator light  in the instrument cluster illuminates when the high beams are on.
- The *headlight flasher* works only as long as you hold the lever - even if there are no lights switched on. The indicator light  in the instrument cluster illuminates when you use the headlight flasher.

Note

Do not use the high beam or headlight flasher in if you know that these could be blinding oncoming traffic. ■

Interior lights

Front interior lights

The front interior lights also contain reading lights for the driver and passenger.



Fig. 61 Headliner:
Front interior lights

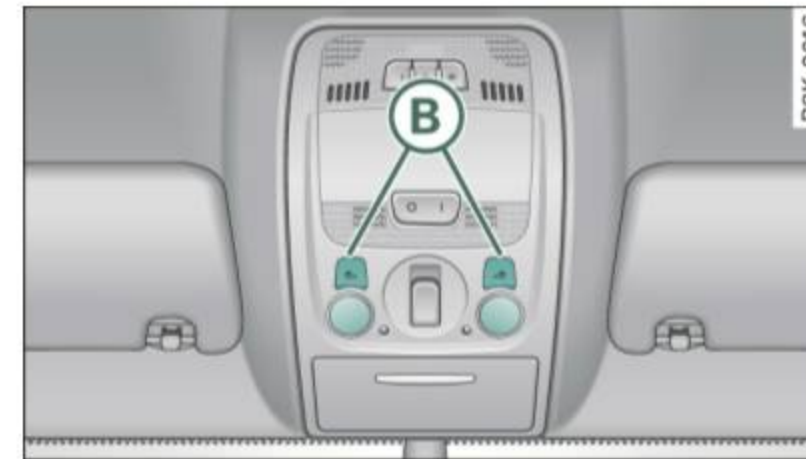



Fig. 62 Headliner:
Front reading lights

The rocker switch  ⇒ fig. 61 for operating the interior lighting has the following functions:

Door contact switch

- Place the switch  in the middle position. ►

Interior light switched on

- Place the switch (A) in position I.

Interior light switched off

- Place the switch (A) in position O.

Front reading lights 

- Press one of the switches (B) ⇒ page 67, fig. 62 to turn the right or left reading light on or off.

With the door contact switch turned on, the interior lights turn on as soon as you unlock the vehicle or open the doors. The lighting is also turned on when the ignition key is removed. The lights go out about 30 seconds after the doors are closed. When the vehicle is locked or when the ignition is turned on, the interior lights are turned off.

When a door is open, the interior lights are turned off after about 10 minutes to prevent draining of the battery.

The brightness of the lights is controlled automatically by a dimmer when they are switched on and off. ■

Rear interior lights

There are reading lights in the rear for the passengers.

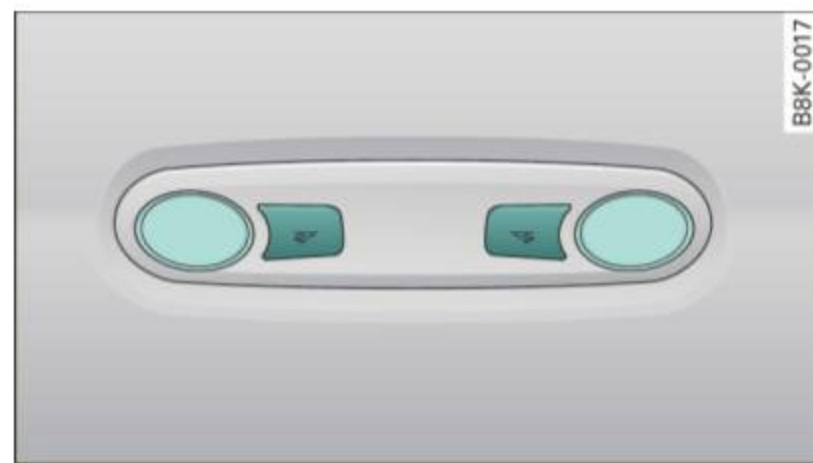


Fig. 63 Headliner: Rear reading lights

The reading lights are switched on and off using the buttons . ■

Vision**Sun visors**

Using the sun visors makes driving safer



Fig. 64 Sun visor

The sun visors for the driver and passenger can be pulled out of their brackets in the center of the vehicle and turned towards the doors ⇒ fig. 64 (1). After the sun visor has been turned to the door, it can be extended lengthwise.

Vanity mirror

The vanity mirrors on the sun visors are covered. When the lid is opened (2), the mirror light in the headliner turns on automatically. It turns off when the lid is closed and the visor is folded up again. ■

Applies to vehicles: with sun shade

Sun shade

The rear window is equipped with a sun shade.




Fig. 65 Push-button for sun shade (version 1)




Fig. 66 Push-button for sun shade (version 2)

Sun shade (rear window)

- Press the  push-button to extend or retract the electric sunshade for the rear window ⇒ fig. 65 ⇒ fig. 66.

If you have switched **on** the **Automatic Rear Sunshade** function in the MMI, the extended rear sunshade will retract when shifting into reverse gear. This improves rear vision when backing up. The sunshade extends again as soon as the reverse gear is disengaged and the vehicle speed is above about 9 mph (15 km/h). The current setting is automatically stored and assigned to the remote key.

If the rear sunshade was automatically retracted in reverse gear, and the ignition was switched off and then on again, the rear sunshade will *not* extend again after reverse gear is disengaged and vehicle speed exceeds 9 mph (15 km/h). The rear sunshade must be extended again using the  button in the cockpit.

After the sun shade for the rear window has reached either of its end positions, it turns off automatically. While the sun shade is extending or retracting it can be turned in the opposite direction by pressing the button again. If the ignition is switched off while the sun shade is moving, the sun shade is not switched off immediately, only when it reaches its end position.

Tips

- If you operate the sun shade several times in short succession, this may cause the overload protection to kick in. You will not be able to operate the sun shade until after a short waiting period.
- Due to the decreasing flexibility of the sun shade material at low temperatures, the controls switch off when the temperature in the vehicle reaches 23 °F (-5 °C). The sun shade cannot be used until the vehicle interior warms up above this temperature. ■

Wiper and washer system

Windshield wiper

The windshield wiper lever controls both the windshield wipers and the washer system.



Fig. 67 Windshield wiper lever

The windshield wiper lever ⇒ fig. 67 has the following positions:

One-touch wiping

- Move the lever to position **①**, when you want to wipe the windshield *briefly*.

Intermittent wiping (activating rain sensor)*

- Move the lever up to position **②**.
- Move switch **A** up or down, to adjust the sensitivity of the rain sensor or to adjust the intermittent interval.

Low wiper speed

- Move the lever up to position **③**.

High wiper speed

- Move the lever up to position **④**.

Automatic wiper/washer

- Pull the lever to position **⑤** (toward the steering wheel) and hold.
- Release the lever. The washer stops and the wipers keep going for about four seconds. Depending on how long the lever is held, different amounts of wipe cycles are performed

Turning off the wipers

- Move the lever back to position **①**.

General information

The windshield wipers and the windshield washer system only operate with the ignition switched on.

During a temporary stop, for example at a traffic signal, the set wipe speed is automatically reduced by one stage.

The windshield washer nozzles are heated at low temperatures when the ignition is on.

Removing water droplets

About 5 seconds after the wash cycle is complete, the wiper system performs a single automatic wipe cycle to remove any water droplets that remain on the windshield.


If you would like to deactivate this delayed wipe cycle while driving, you have to pull the lever to position **⑤** again within 10 seconds after this wipe cycle.

Water droplet removal is reactivated after the ignition is switched off and then on again. 

Rain sensor*

The rain sensor operates only in the interval wiper position. When it starts to rain, the interval wiper mode is activated automatically.

If the windshield wiper lever is in the interval wipe position with the ignition switched off, the rain sensor is not activated until vehicle speed is above 4 mph (6 km/h).

To reduce the sensitivity of the rain sensor, the switch  ⇒ *page 70*, fig. 67 must be moved to the left. To increase the sensitivity of the rain sensor, the switch must be moved to the right.

The higher the sensitivity setting, the sooner the windshield wipers react to moisture on the windshield. The pauses for interval wipe are controlled depending on vehicle speed, in addition to the sensitivity selected.

WARNING

- **Wiper blades are crucial for safe driving! Only when they are in good condition are they able to clear the windows properly to provide uncompromised visibility. Worn or damaged wiper blades are a safety hazard ⇒ *page 73*, “Installing new wiper blades”!**
- **The rain sensor is only designed to assist and support the driver. It remains entirely the driver's responsibility to monitor outside weather conditions and to manually activate the wipers as soon as rain or drizzle reduces visibility through the windshield.**
- **The windshield must not be treated with water-repellent materials. They can increase glare under poor visibility conditions such as wetness, darkness, or when the sun is low on the horizon. In addition, they can cause the windshield wipers to chatter.**

Note

In freezing or near freezing conditions:

- Always check that the wiper blades are not frozen to the glass before you turn the wipers on. Loosen a wiper blade which is frozen

in place before operating the wipers to prevent damage to the wiper blade or the wiper motor.

- Do not use the wipers to clear a frosted window. Using the wipers as a convenient ice scraper will destroy the wiper blades.
- Before you take your vehicle to an automatic car wash, make sure you have the windshield wiper system switched off (lever in position 0), otherwise the windshield wiper system could get damaged in the car wash if it should suddenly come on.

Tips

- Make sure the washer fluid reservoir in the engine compartment is topped off before going on a long trip. Look up ⇒ *page 275* for checking and filling the washer container.
- Worn or dirty windshield wiper blades cause smearing which can affect the operation of the rain sensor. Check the condition of your windshield wiper blades regularly. ■

Applies to vehicles: with headlight washer system

Headlight washer system

The headlight washer system operates only when the headlights are on.

- Move the lever for the automatic wipe/wash to position  ⇒ *page 70*, fig. 67.

The headlight washer system is always activated with the first time the automatic wipe/wash system is operated. After that, it is activated only every fifth time. If the automatic wipe/wash system is operated for longer than 2 seconds, the headlights are also washed.

The washer nozzles extend from the front bumper under water pressure to clean the headlights. ►

You should, however, remove encrusted debris (such as insects) from your headlight lenses on a regular basis, for example when you refuel your car.

In order to ensure operation in the winter, you should clear snow and ice from the wiper nozzles using a de-icing spray. ■

Service position

The windshield wiper blades are replaced in the service position.



Fig. 68 MMI Display: Windshield wipers

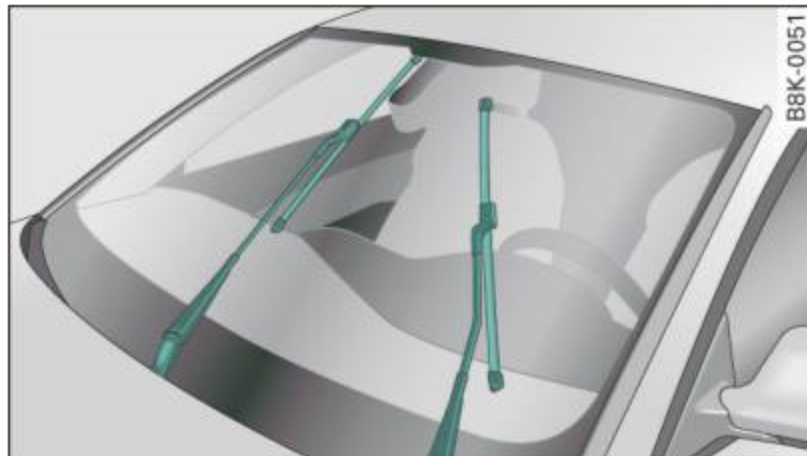


Fig. 69 Service position

The service position is set in the radio or in the MMI*.

- If the wiper blades are not frozen to the windshield, bring the windshield wiper lever to the basic position ① ⇒ *page 70, fig. 67.*
- Select: Function button **CAR** > **Windshield wipers** > **Service position** ⇒ *fig. 68.*
 - **On** - changing the windshield wiper blades can only be done if you bring the wiper arms to the service position ⇒ *fig. 69.* You will also avoid paint damage to the hood when working on the wipers in this position.
 - **Off** - the windshield wipers are moved to their initial position again.

! Note

Never maneuver your vehicle with the front windshield wiper arms raised since they will automatically be moved back to their basic position above a speed of 3 mph (6 km/h) and can scratch the hood.

i Tips

- You can also use the service position, for example, if you want to protect the windshield from icing by using a cover.
- The service position automatically switches to **off** when you operate the windshield wiper lever, or speed exceeds 3 mph (6 km/h). ■

Installing new wiper blades

Wiper blades in good condition help keep the windshield clear.

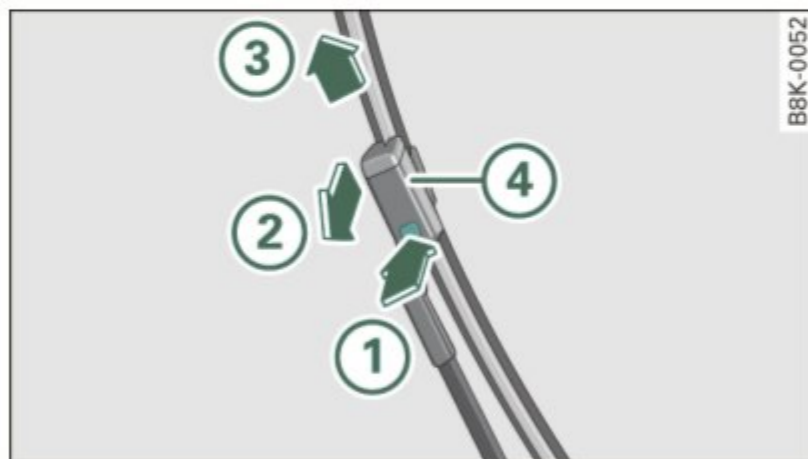


Fig. 70 Removing the wiper blade

Removing the wiper blade

- Bring the windshield wipers to the service position ⇒ *page 72*.
- Lift the windshield wiper arm up from the windshield.
- Press the lock button ① on the wiper blade ⇒ *fig. 70*. Hold the wiper blade and slightly push it forward ②.
- Push the wiper blade up ③.

Attaching the wiper blade

- Install the new wiper blade in the retainer on the wiper arm ④ until you hear it click into place on the wiper arm.
- Place the wiper arm back on the windshield.

WARNING

- Clean your wiper blades regularly with a windshield washer solution to prevent streaking. If the wiper blades are very dirty, for

WARNING (continued)

example with insects, carefully clean the wiper blades with a sponge or a soft brush.

- For your safety, you should replace the wiper blades once or twice a year. See your authorized Audi dealer for replacement blades.

Note

- The windshield wiper blades must only be replaced when in the service position ⇒ *page 72*! Otherwise, you risk damaging the paint on the hood or the windshield wiper motor.
- To prevent damage to the wiper system, always loosen blades which are frozen to the windshield before operating wipers.
- To prevent damage to wiper blades, do not use gasoline, kerosene, paint thinner, or other solvents on or near the wiper blades.
- To prevent damage to the wiper arms or other components, do not attempt to move the wipers by hand.

Tips

Commercial hot waxes applied by automatic car washes affect the how easily the glass surface can be cleaned. ■

Mirrors

Manual glare-dimming

Standard setting

- Move the small lever (located on the bottom edge of the mirror) to the front. ▶

Anti-glare setting

- Move the small lever (located on the bottom edge of the mirror) to the rear. ■

Applies to vehicles: with automatically dimming inside mirror

Automatically dimming inside mirror

The automatic dimming function can be turned on and off if required.

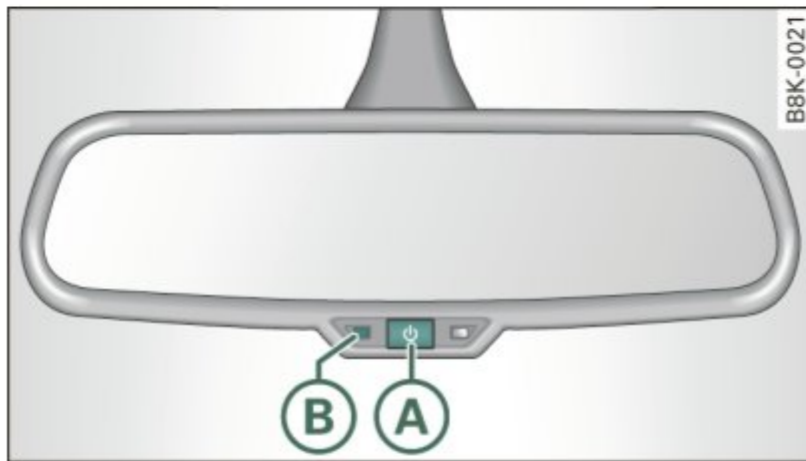


Fig. 71 Inside rear view mirror

Disabling auto dimming

- Press button **A** ⇒ fig. 71 *briefly*, - the indicator light **B** goes out.

Activating/reactivating auto dimming

- Press button **A** *briefly*, - the indicator light **B** goes on.

Automatic dimming function

The automatic dimming function is activated every time the ignition is turned on. The green indicator light is lit to indicate auto dimming is active.

When dimming is activated, the inside mirror will darken *automatically* in response to the amount of light striking the mirror (such as

headlights from rearward approaching vehicles). Even in dimming mode, the mirror surface turns bright when:

- the interior light is switched on
- reverse gear is engaged.

WARNING

The glass of the inside rearview mirror is layered and contains an electrolyte to achieve its properties. Be aware of liquid electrolyte leaking from a broken mirror glass. This liquid can cause irritation to skin, eyes, and respiratory system. If you get electrolyte in your eyes or on your skin, immediately rinse with plenty of water. If irritation persists, seek medical attention.

Note

Liquid electrolyte leaked from a broken mirror glass will damage any plastic surfaces it comes in contact with. Clean up spilled electrolyte immediately with clear water and a sponge.

Tips

- **If you switch off the automatic dimming function on the inside mirror, automatic dimming of the outside mirrors will likewise be disabled.**
- Check to make sure there are no objects preventing light from reaching the inside mirror.
- Do not attach any stickers to the windshield in front of the light sensor, as this would interfere with both the automatic operation of the headlights and the automatic dimming of the inside mirror.
- Be aware that automatic dimming of the inside mirror can only operate properly if the rear window sun blind* is retracted. ■

Outside mirrors

The outside mirrors are electrically adjusted (power mirrors)

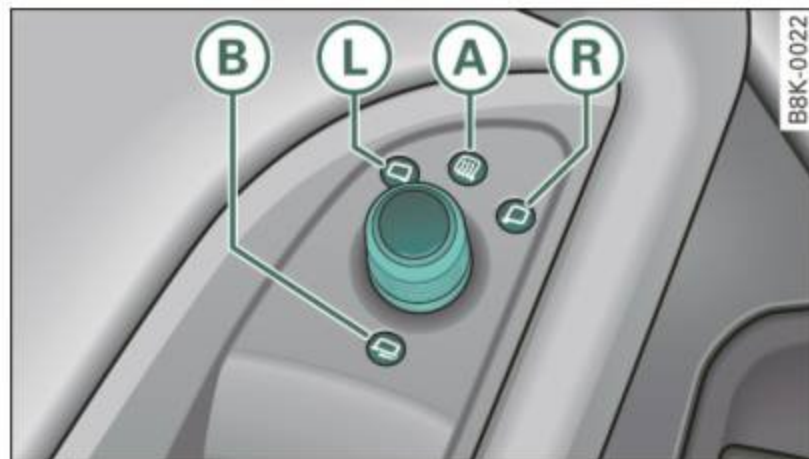


Fig. 72 Forward section of driver's armrest: power mirror controls

Adjusting exterior mirrors

- Rotate the knob to the **L** position (driver's exterior mirror) or to the **R** position (passenger's exterior mirror) ⇒ fig. 72.
- Rotate the knob and the mirror so that you have a clear view to the rear.

Heated mirrors

- Rotate the knob to position **A**.

Folding both outside mirrors*

- Turn the knob to **B**.

Depending on the outside temperature, the mirror surfaces are heated until the ignition is switched off - even if the knob is no longer in position **A**.

Folding* the exterior mirrors is recommended when parking or in restricted spaces.

Memory for exterior mirrors*

On vehicles with memory for the driver's seat, the current setting for the exterior mirrors is automatically stored along with the seat position ⇒ page 83.

Tilt function for the passenger's mirror* (only with memory for exterior mirrors)

When the reverse gear is engaged, the mirror surface tilts downward slightly if the setting is for the passenger's mirror (knob in position **R** ⇒ fig. 72). This allows you to see the curb during parallel parking.

The mirror returns to its initial position as soon as reverse gear is disengaged and vehicle speed is above about 9 mph (15 km/h). The mirror also returns to its initial position if the switch is moved to the driver's outside mirror **L** or the ignition is switched off.

If the position of the mirror surface is changed on a tilted mirror, this new position will be automatically assigned to the remote key when the vehicle is taken out of reverse gear.

! Note

- Curved mirror surfaces (convex or spherical*) increase your field of view. Remember that vehicles or other objects will appear smaller and farther away than when seen in a flat mirror. If you use this mirror to estimate distances of following vehicles when changing lanes, you could estimate incorrectly and cause an accident.
- If the mirror housing is moved unintentionally (for example, while parking your vehicle), then you must first fold the mirror electrically. Do not readjust the mirror housing manually. You could damage the motor which controls the mirror.

i Tips

If there should be a malfunction in the electrical system, you can still adjust the outside mirrors by pressing the edge of the mirror. ■

Applies to vehicles: with automatically adjusting outside mirrors

Automatic dimming for the outside mirrors

The outside mirrors dim at the same time as the inside mirror. When the ignition is switched on, the mirrors automatically dim depending on the amount of light striking the mirrors (such as headlights shining into the vehicle from the rear).

When the interior lighting is switched on and when reverse gear is engaged, the mirrors are switched back to their original brightness (not dimmed).

WARNING

The glass of the inside rearview mirror is layered and contains an electrolyte to achieve its properties. Be aware of liquid electrolyte leaking from a broken mirror glass. This liquid can cause irritation to skin, eyes, and respiratory system. If you get electrolyte in your eyes or on your skin, immediately rinse with plenty of water. If irritation persists, seek medical attention.

Note

Liquid electrolyte leaked from a broken mirror glass will damage any plastic surfaces it comes in contact with. Clean up spilled electrolyte immediately with clear water and a sponge.

Tips

- **Switching off the dimming function of the inside rearview mirror also deactivates the automatic dimming function of the exterior mirrors.**
- Automatic dimming for the mirror only operates properly if the sun shade* for the rear window is not in use or the light striking the inside mirror is not hindered by other objects. ■

Digital compass

Applies to vehicles: with digital compass

Activating or deactivating the compass

The direction is displayed on the interior rear view mirror.

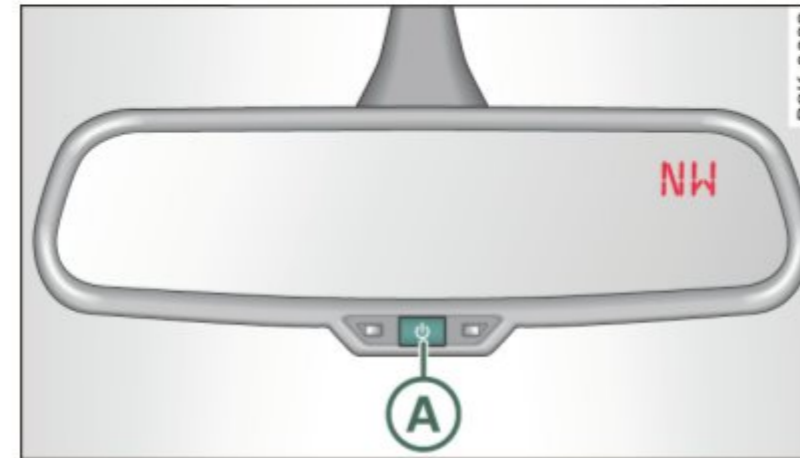



Fig. 73 Inside rear view mirror: digital compass activated

- To activate or deactivate, hold the  button down until the red display appears or disappears.

The digital compass only works with the ignition turned on. The directions are displayed as initials: **N** (North), **NE** (Northeast), **E** (East), **SE** (Southeast), **S** (South), **SW** (Southwest), **W** (West), **NW** (Northwest).

Tips

To avoid inaccurate directions, do not allow any remote controls, electrical systems, or metal parts close to the mirror. ■

Applies to vehicles: with digital compass

Setting the magnetic deflection zone

The correct magnetic deflection zone must be set in order to display the directions correctly.



Fig. 74 North America: magnetic deflection zone boundaries

- Hold the **(A)** ⇒ *page 76, fig. 73* button down until the number of the set magnetic deflection zone appears on the interior rear view mirror.
- Adjust the magnetic deflection zone by repeatedly pressing on the **(A)** button. The set mode automatically deactivates after a few seconds. ■

Applies to vehicles: with digital compass

Calibrating the compass

The compass has to be recalibrated if the display is wrong or inaccurate.

- Hold the **(A)** button down until the letter **C** is displayed on the interior rear view mirror.
- Drive in a circle at a speed of about 5 mph (10 km/h) until a direction is shown on the interior rear view mirror.

! WARNING

The digital compass is to be used as a directional aid only. Even though you may want to look at it while you are driving, you must still pay attention to traffic, road and weather conditions as well as other possible hazards. ■

Seats and storage

General recommendations

Why is your seat adjustment so important?

The safety belts and the airbag system can only provide maximum protection if the front seats are correctly adjusted.

There are various ways of adjusting the front seats to provide safe and comfortable support for the driver and the front passenger. Adjust your seat properly so that:

- you can easily and quickly reach all the switches and controls in the instrument panel
- your body is properly supported thus reducing physical stress and fatigue
- the safety belts and airbag system can offer maximum protection ⇒ *page 172*.

In the following sections, you will see exactly how you can best adjust your seats.

There are special regulations and instructions for installing a child safety seat on the front passenger's seat. Always follow the information regarding child safety provided in ⇒ *page 197, "Child Safety"*.

WARNING

Incorrect seating position of the driver and all other passengers can result in serious personal injury.

- **Always keep your feet on the floor when the vehicle is in motion – never put your feet on top of the instrument panel, out of the window or on top of the seat cushion. This applies especially to the passengers. If your seating position is incorrect, you increase the risk of injury in the case of sudden braking or an accident. If**

WARNING (continued)


the airbag inflates and the seating position is incorrect, this could result in personal injury or even death.

- **It is important for both the driver and front passenger to keep a distance of at least 10 inches (25 cm) between themselves and the steering wheel and/or instrument panel. If you're sitting any closer than this, the airbag system cannot protect you properly. In addition, the front seats and head restraints must be adjusted to your body height so that they can give you maximum protection.**
- **Always try to keep as much distance as possible between yourself and the steering wheel or instrument panel.**
- **Do not adjust the driver's or front passenger's seat while the vehicle is moving. Your seat may move unexpectedly, causing sudden loss of vehicle control and personal injury. If you adjust your seat while the vehicle is moving, you are out of position. ■**

Driver's seat

The correct seat position is important for safe and relaxed driving.

We recommend that you adjust the driver's seat in the following manner:

- Adjust the seat in fore and aft direction so that you can easily push the pedals to the floor while keeping your knees slightly bent ⇒  in "Why is your seat adjustment so important?".
- Adjust the seatback so that when you sit with your back against the seatback, you can still grasp the top of the steering wheel. ►

- Position the head restraint according to the occupant's height ⇒ *page 85*. For maximum protection, the top of the head restraint should be at least at eye level, preferably higher and ideally level with the top of the head ⇒ *page 157*, fig. 160.


WARNING

Never place any objects in the driver's footwell. An object could get into the pedal area and interfere with pedal function. In case of sudden braking or an accident, you would not be able to brake or accelerate. ■

Front passenger's seat

Always move the front passenger seat into the rearmost position.

To avoid contact with the airbag while it is deploying, do not sit any closer to the instrument panel than necessary and always wear the three-point safety belt provided adjusted correctly. We recommend that you adjust the passenger's seat in the following manner:

- Move the front passenger seat into the rearmost position of the fore and aft adjustment range ⇒  in "Why is your seat adjustment so important?" on *page 78*.
- Bring the backrest up to an (almost) upright position. **Do not** ride with the seat reclined.
- The ideal position for the head restraint is with the upper edge of the restraint level with the top of your head ⇒ *page 85*. You should *not* lower the top of the restraint below the level of your eyes.

- Place your feet on the floor in front of the passenger's seat. ■

Adjusting front seats manually

Applies to vehicles: with manually adjustable seats

Seat adjustment controls

The seat has several adjustments

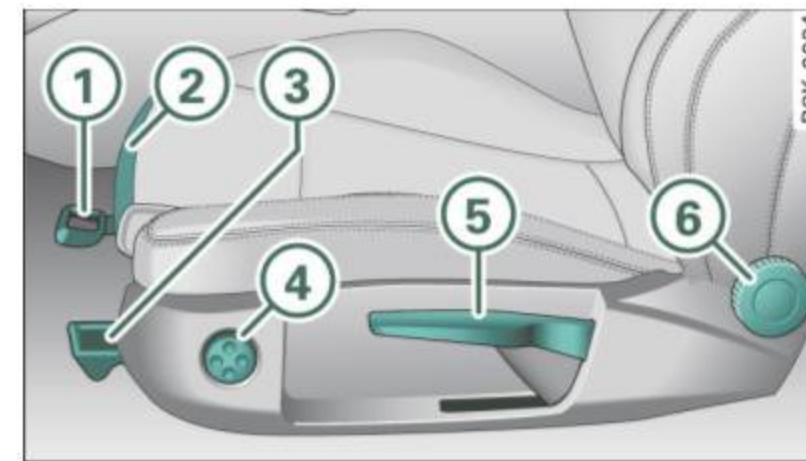


Fig. 75 Controls on the driver's seat

Some the controls shown are only installed in certain model versions or are supplied as an option.


Controls

- ① Fore-and-aft adjustment
- ② Upper thigh support *
- ③ Adjusting seat cushion angle*
- ④ Adjusting lumbar support*
- ⑤ Adjusting seat height
- ⑥ Adjusting seat back angle ■



Applies to vehicles: with manually adjustable seats

Adjusting the seat


Position and shape of the seat can be adjusted manually to ensure safe and comfortable seating.

Read and follow the warning notices ⇒  before you adjust your seat.

Fore-and-aft adjustment

- Pull the lever  ⇒ page 79, fig. 75 up and push the seat to the desired position.
- Release the lever  and continue to move the seat until it locks into place.

Lengthening or shortening upper thigh support*

- Lift the button  under the seat cushion. The front seat cushion moves forward under spring force.
- Push the seat cushion back when you have finished using it.

Adjusting seat cushion angle*

- Pull or push the lever  ⇒ page 79, fig. 75 up or down (pumping motion).

Adjusting the curvature of the lumbar support*

- Push the switch plate  forward or backward to increase or reduce the curvature.


Adjusting the height of the lumbar support*

- Push the switch plate  up or down to position the curvature higher or lower.

Raising or lowering seat height

- Pull or push the lever  ⇒ page 79, fig. 75 up or down (pumping motion).

Adjusting seat back angle

- Remove weight from the seat back (do not lean against it).
- Turn the hand wheel  ⇒ page 79, fig. 75 to adjust the angle of the seat back accordingly.

WARNING

- Adjust the driver's seat only when the vehicle is stationary. You risk an accident otherwise.
- Exercise caution when adjusting the seats. Adjusting the seat carelessly or without checking can pinch hands and fingers.
- While the vehicle is moving, the seat backs of the front seats must not be inclined too far to the rear because the effectiveness of the safety belts and the airbag system is severely compromised - there is a risk of injury. ■

Applies to vehicles: with manually adjustable seats

Easy entry

Easy entry makes it easier for the rear passengers to enter and leave the vehicle.

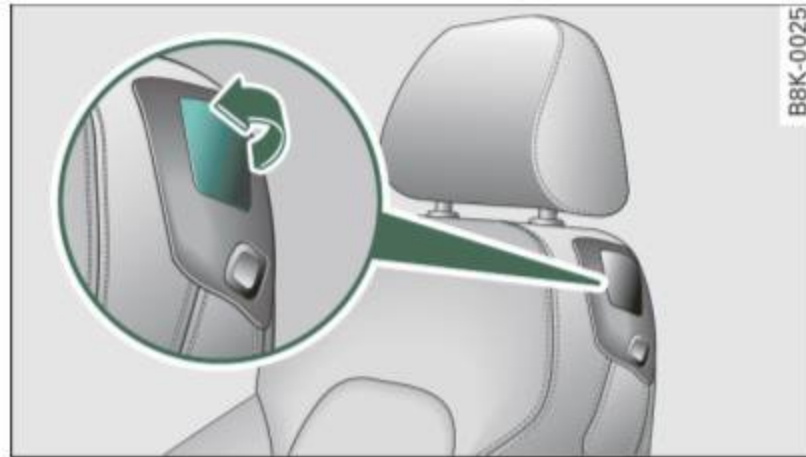


Fig. 76 Driver's seat:
Latch on the seat back

Tilt the seat back forward and push the front seats forward

- Lift the latch ⇒ fig. 76.
- Hold the latch and tilt the seat back forward.
- Release the latch and push the seat forward.

Push the front seats back and fold the seat back up

- Push the front seat back *before* you fold the seat backs up. Otherwise the seat cannot be pushed back to its original position.

WARNING

Always be certain that the front seats are upright and securely latched when you drive. ■

Power front seat adjustment

Applies to vehicles: with power adjustable seats

Seat adjustment controls

The operating logic for the switches corresponds to the construction and function of the seat.

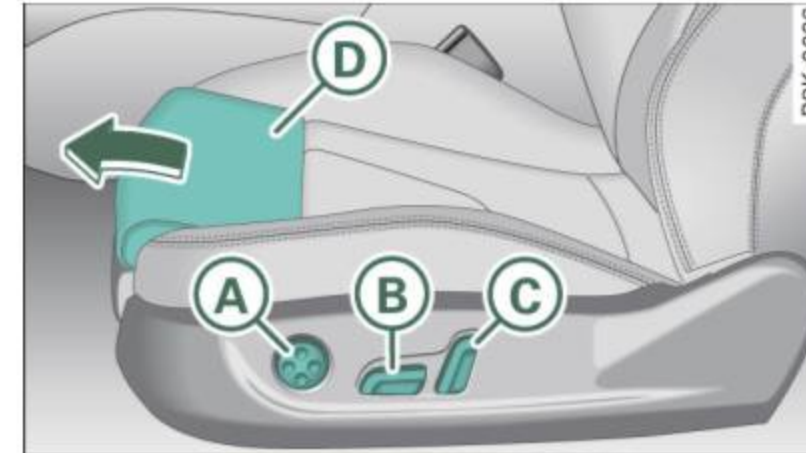


Fig. 77 Front seat:
Controls for seat
adjustment

The switches to adjust the seat cushion and the seat back correspond to the layout, the design and the function of the seat. The seats are adjusted by moving the switches following this logic.


Controls

- (A) Lumbar support
- (B) Seat adjustment
- (C) Seat back and head restraint height adjustment*
- (D) Upper thigh support * ■

Applies to vehicles: with power adjustable seats

Adjusting the seat

Position, angle and shape of the seat can be adjusted electrically to ensure safe and comfortable seating.

Read and follow the warning notices ⇒  before you adjust your seat.


Adjusting the curvature of the lumbar support

- Push the switch plate  forward or backward to increase or reduce the curvature.

Adjusting the height of the lumbar support

- Push the switch plate  up or down to position the curvature higher or lower.

Fore-and-aft adjustment

- Push the switch  forward or backward ⇒ *page 81, fig. 77.*

Adjusting seat height

- Pull or push the switch  up or down.

Front seat cushion up / down

- Press the switch  at the front up or down.


Rear seat cushion up / down

- Press the switch  at the rear up or down.


Adjusting seat back angle

- Push the switch  forward or backward.

Head restraint height adjustment*

- Press the switch  from up to down or the other way.

Lengthening or shortening upper thigh support*

- Lift the button  under the seat cushion. The front seat cushion moves forward under spring force.
- Push the seat cushion back when you have finished using it.

WARNING

- Adjust the driver's seat only when the vehicle is stationary. You risk an accident otherwise.
- The power adjustment for the front seats also works with the ignition switched off or with the ignition key removed. For this reason, children should never be left unattended in the vehicle - they could be injured!
- Exercise caution when adjusting the seat height. Unsupervised or careless seat adjustment can pinch fingers or hands causing injuries.
- While the vehicle is moving, the seat backs of the front seats must not be inclined too far to the rear because the effectiveness of the safety belts and the airbag system is severely compromised - there is a risk of injury. ■

Applies to vehicles: with power adjustable seats

Easy entry

Easy entry makes it easier for the rear passengers to enter and leave the vehicle.

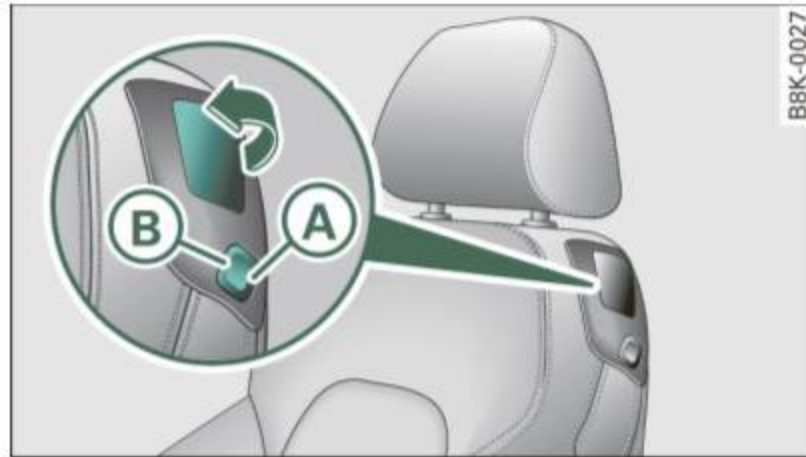


Fig. 78 Driver's seat: Controls for easy entry assist

Folding down the front seat backs

- Lift the latch ⇒ fig. 78.
- Tilt the seatback forward.

Moving the front seats forward

- Press and hold the switch (A) until the seat has reached the desired position.

Moving front seats back

- Press and hold the switch (B) until the seat has reached the desired position. The seat stops automatically when it has reached its starting position again.

To make it easier to enter and leave the rear seat, the seatbacks of the front seats can be folded forward and the head restraints are automatically lowered. At the same time, the front seats can be moved forward and back.

When the front seats are moved forward, their original position is stored. When it is moved back, the seat automatically stops in this position. To move the seat even further back, you have to release the switch (B) and reactivate it.

The head restraints from the front seats, depending on the seat height that has been set, are automatically retracted when the seatbacks are folded down. They return to their original position again when the seatbacks for the front seats are raised.

Tips

With the driver's or passenger's door closed, the corresponding switch to move the seat is inoperative. ■

Seat memory

Applies to vehicles: with seat memory

Memory for driver's seat

The seat adjustment settings for two drivers can be stored using the memory buttons in the driver's door.



Fig. 79 Driver's door: Seat memory

In addition to the setting for the driver's seat, the exterior rear view mirror setting can be stored and recalled through seat memory if the vehicle is properly equipped. ►

Storing and recalling settings

With the help of the memory buttons 1 and 2 ⇒ *page 83, fig. 79* the settings for two different drivers can be stored and recalled ⇒ *page 84*.

The current settings are also automatically stored on the remote control key being used when the vehicle is locked. When the vehicle is unlocked, the settings stored on the remote control key being used are automatically recalled.

Turning seat memory on and off

If the **ON/OFF** switch is depressed, the seat memory is inoperative. The word **OFF** in the **ON/OFF** switch illuminates.

All the stored settings are retained. We recommend using the **ON/OFF** switch and deactivating the seat memory if the vehicle is only going to be used *temporarily* by a driver whose settings are not going to be stored. ■

Applies to vehicles: with seat memory

Storing and recalling settings

Before you can store or recall your settings, the **ON/OFF** switch on the seat memory must be engaged (not raised).

Storing settings

- Adjust the driver's seat.
- Adjust the two exterior mirrors.
- Press the **SET** button and hold it down. In addition, press one of the memory buttons for at least one second.
- Release the buttons. The settings are now stored under the corresponding memory button.

Recalling settings

- If the driver's door is open, tap the corresponding memory button briefly.
- If the driver's door is closed, press the appropriate memory button until the stored position is reached.

Successful storage is confirmed audibly and by the light in the **SET** button illuminating ⇒ *page 83, fig. 79*.

When the vehicle is **locked**, the current settings are stored and assigned to the remote control key. But the settings stored on memory buttons 1 to 2 are not deleted. They can be recalled at any time. When the vehicle is **unlocked**, the settings stored on the remote control key are restored.

If your vehicle is driven by other persons using your remote control key, you should save your individual seat position on one of the memory buttons. You can recall your settings again simply and conveniently by pressing the corresponding memory button. When the vehicle is locked, these settings are automatically re-assigned to the remote control key and stored.

WARNING

- For safety reasons, the seat setting can only be recalled when the vehicle is stationary - otherwise you risk having an accident.
- In an emergency the recall procedure can be cancelled by pressing the **ON/OFF** switch or by tapping of the the memory buttons. ■

Applies to vehicles: with seat memory

Activating remote control key memory

To be able to recall the stored settings with the remote control key, the function has to be activated in the radio or in the MMI.

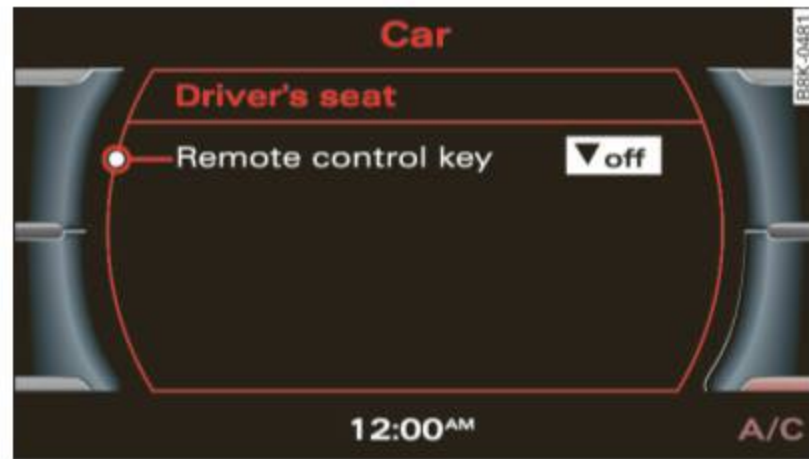


Fig. 80 MMI display: Driver's seat

- Select: Function button **CAR** > **Seat setting** > **Driver's seat** > **Remote control key** > On. ■

Head restraints

Adjusting the front head restraints

Head restraints that are adjusted according to body size, along with the seat belt, offer effective protection.

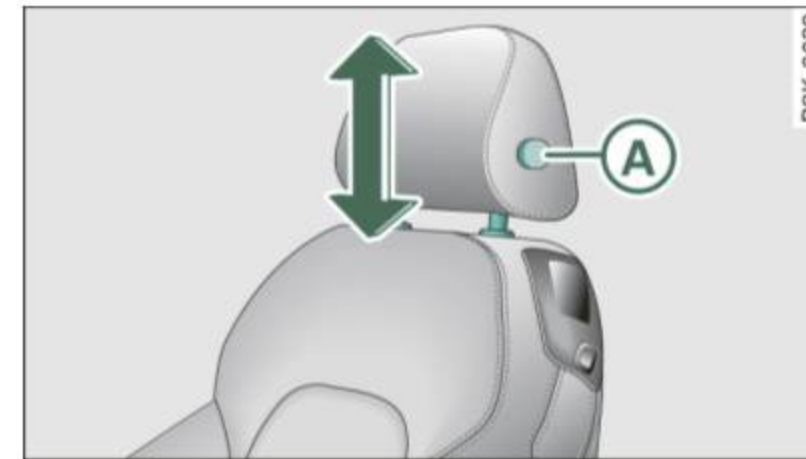


Fig. 81 Front seat: Adjusting the head restraint

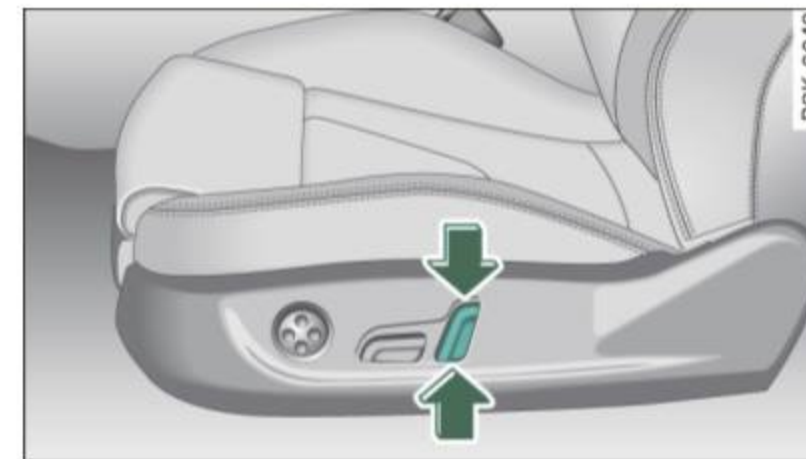


Fig. 82 Front seat: Adjusting head restraint electrically*

Raising the head restraint

- Grasp the sides of the head restraint with both hands.
- Push the head restraint up.

Lowering the head restraint

- Grasp the sides of the head restraint.

- Press the button **(A)** ⇒ *page 85*, fig. 81 and push the head restraint down.

Electric height adjustment*

- Push the switch up or down ⇒ *page 85*, fig. 82 to adjust the height of the head restraint.
- Adjust the head restraints so that the top of the head restraint is *at least* level with your eyes or higher ⇒ *page 85*, fig. 81.

The most effective protection is achieved when the top of the head restraint is at least level with your eyes or higher.

The head restraints are adjustable for height. They should be adjusted according to body size. Along with the safety belts, correctly adjusted head restraints offer effective protection. ■

Adjusting the rear head restraints

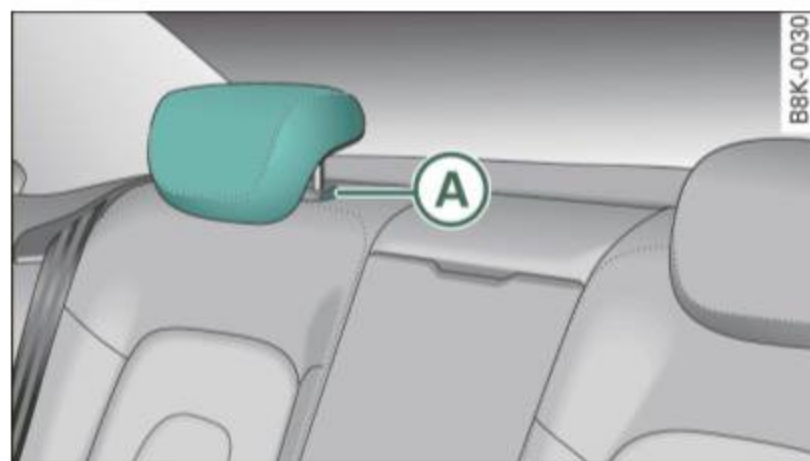


Fig. 83 Rear seats:
Head restraint

Raising the head restraint

- Grasp the sides of the head restraint with both hands.
- Move the head restraint upward as far as it can go.

Lowering the head restraint

- Grasp the sides of the head restraint.
- Press the button **(A)** ⇒ fig. 83 and push the head restraint down.

The most effective protection is achieved when the top of the head restraint is at least level with your eyes or higher.

So that the driver can have a better view to the rear, the head restraints should be pushed down completely when the rear seats are not occupied. ■

Applies to vehicles: with front arm rest

Front arm rest

The arm rest is adjustable in several stages and can be moved forward and back.

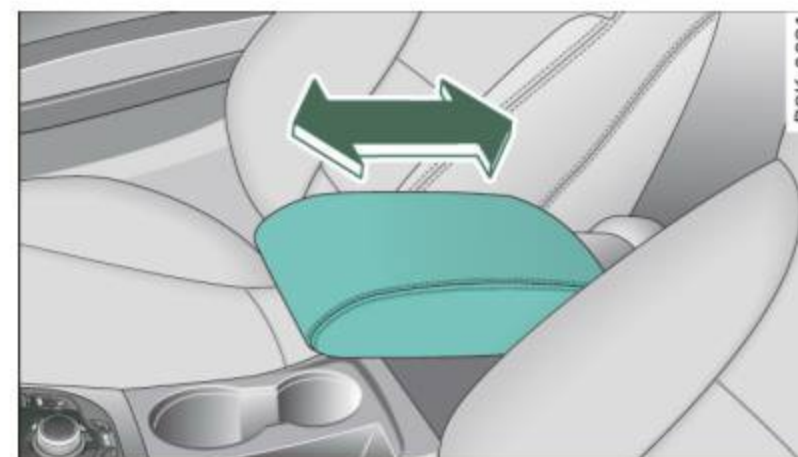


Fig. 84 Arm rest
between driver's and
passenger's seat

Adjusting the arm rest

- To adjust the arm rest angle, pivot the arm rest fully down.
- Lift the arm rest detent by detent until the desired position is reached. ►

Moving the arm rest

- You can move the arm rest forward or back ⇒ *page 86*, fig. 84.

Please note that the driver's arm movements may be restricted with the arm rest folded down. In city traffic the arm rest should be moved to the rear.

There is a storage compartment under the arm rest. ■

Luggage compartment

Loading luggage compartment

Items of luggage must be stowed securely.

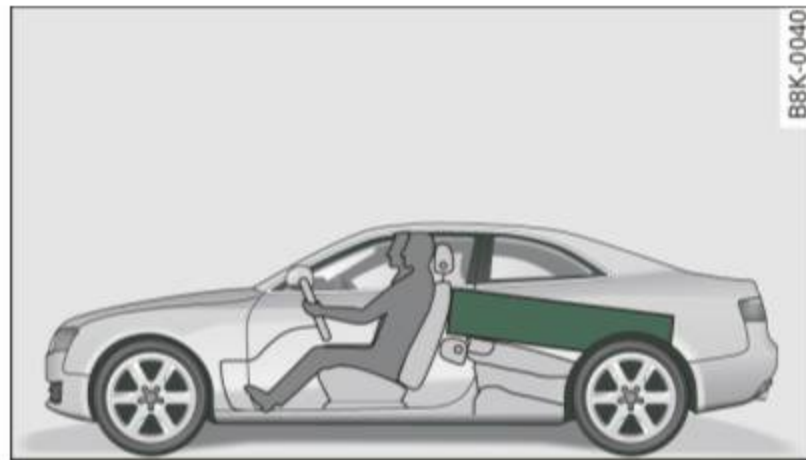


Fig. 85 Place heavy objects as far forward as possible.

Note the following to preserve the vehicle's good handling characteristics.

- Distribute the load as evenly as possible.
- Place heavy objects as far forward as possible ⇒ fig. 85.
- Secure the items of luggage with the cargo net* or with non-elastic retaining straps to the tie-downs* ⇒ *page 87*.

WARNING

- Loose objects in the luggage compartment can slide about suddenly and alter the vehicle's handling characteristics.
- Loose objects in the passenger compartment can fly forward during abrupt maneuvers or accidents and injure occupants.
- Always store objects in the luggage compartment and use suitable straps, particularly with heavy objects.
- When you transport heavy objects, always remember that a change in the center of gravity may result in a change in the vehicle's handling characteristics.
- Follow all warnings ⇒ *page 152*, "Driving Safely"

Tips

The tire pressure must be adjusted to the load - see the tire pressure sticker on the edge of the driver's door. ■

Applies to vehicles: with tie-down eyelets

Tie-down eyelets

The luggage compartment is equipped with four tie-down eyelets to secure luggage and other items.

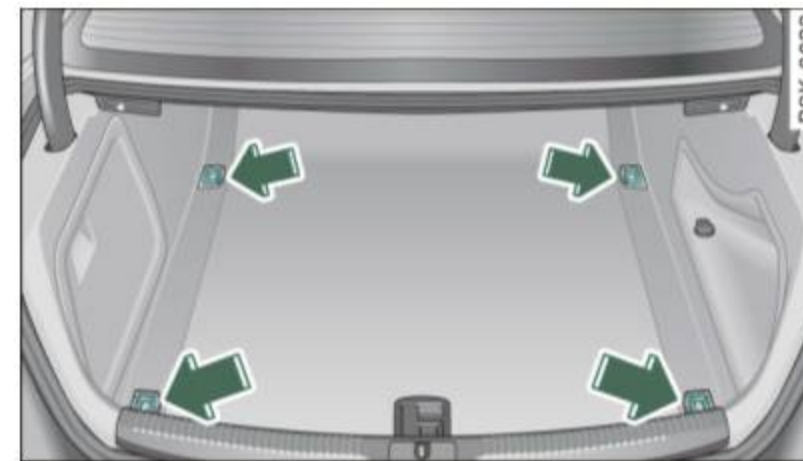


Fig. 86 Location of the tie-down rings in the luggage compartment ▶

- Secure the cargo to the tie-down rings ⇒ *page 87, fig. 86* -Arrows-.
- Observe the safety notes ⇒ *page 161*. ■

Applies to vehicles: with cargo net

Cargo net/Storage net

The cargo net/storage net prevents light objects from sliding about in the luggage compartment.

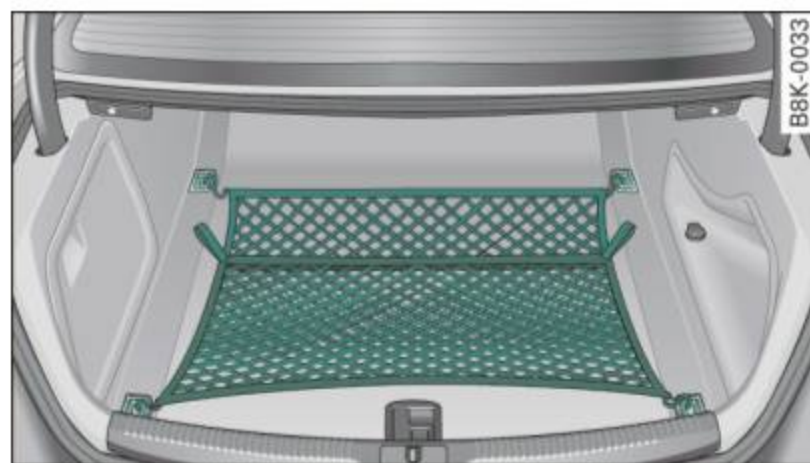


Fig. 87 Cargo net unhooked



Fig. 88 Cargo net hooked up

Cargo net

- First, hang the *front* hooks in the fastening eyelets ⇒ *fig. 87*.

- Then, hang the *rear* hooks in the fastening eyelets.

Storage net

- Engage the hooks on the cargo net in the fastening eyelets in the floor at the rear of the luggage compartment ⇒ *fig. 88*.
- Fold down the attaching hooks in the upper area of the luggage compartment, pull the net up and hang the eyelets on the net into the hooks.

You can use the attaching hooks ⇒ *fig. 88* to hang bags, sacks, etc. If nothing is attached to the hooks, they fold back by themselves.

WARNING

For reasons of strength, only objects with a maximum weight of 5 kg should be carried in the storage net. Heavier objects are not adequately secured. There is risk of personal injury. ■

Side storage compartment

The DVD player for the navigation system is located in the left side storage compartment in the luggage compartment.*



Fig. 89 Luggage compartment: Trim panel with closed storage compartment ►

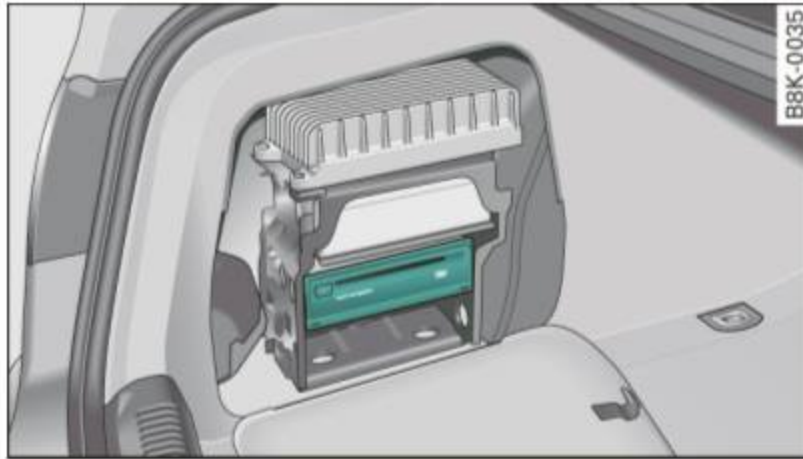


Fig. 90 Luggage compartment: DVD player for navigation system

- To open, pull the handle forward ⇒ *page 88*, fig. 89.

DVD player for Navigation system*

The DVD player for the navigation system ⇒ fig. 90 is located in this storage compartment in the luggage compartment. You can find the description in the Infotainment/MMI operator's guide. ■

Applies to vehicles: with folding seat back

Enlarging cargo capacity of the luggage compartment

The seat backs can be folded forward to enlarge the cargo capacity.

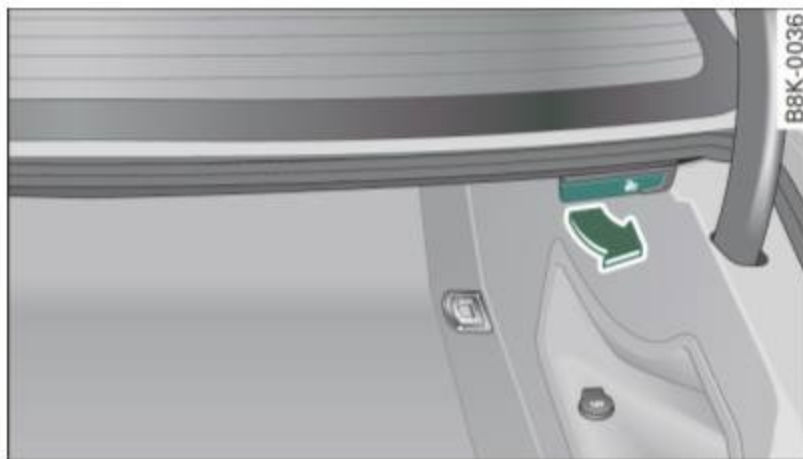


Fig. 91 Release lever in cargo area

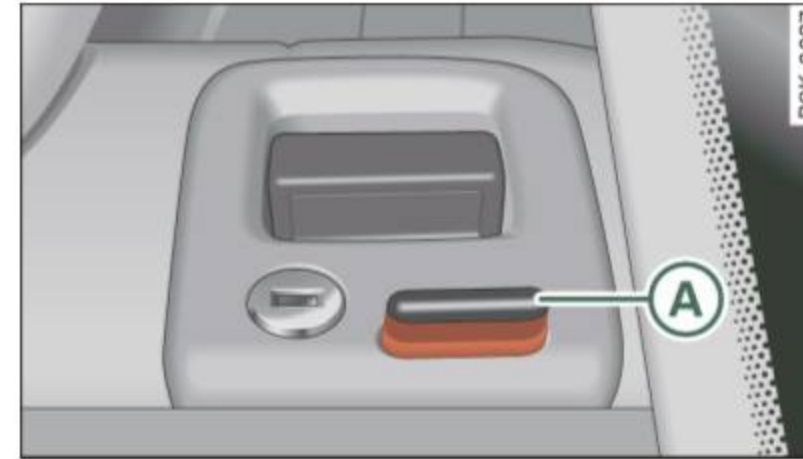


Fig. 92 Safety knob

Unlocking and tipping seat back forward

- When you pull the release lever ⇒ fig. 91 in the direction of the arrow, the safety knob (A) ⇒ fig. 92 pops out far enough for the red marking on knob to be visible.
- Tilt the seatback forward.

Raising the seatback

- Raise the seatback until it is securely latched ⇒ ⚠. When you can no longer see the red mark on the safety knob (A) ⇒ fig. 92, the seat is latched.

The correctly latched seat back (basic position) can be locked and unlocked with the mechanical key. This prevents any entry from the vehicle interior into the luggage compartment.

Enlarging the cargo capacity of the luggage compartment is only possible when the seat back has not been locked with the mechanical key.

⚠ WARNING

The seat back must be securely latched so that objects cannot slide forward out of the luggage compartment during sudden braking.

! Note

Make sure when raising the seatback that the rear safety belts are in the guide so that are not pinched in the seatback lock and damaged. Other objects should be removed from the rear seat bench to protect the seatback from damage. ■

Applies to vehicles: with folding seat back

Enlarging cargo capacity of the vehicle interior

The seat backs can be folded forward to enlarge the cargo capacity.

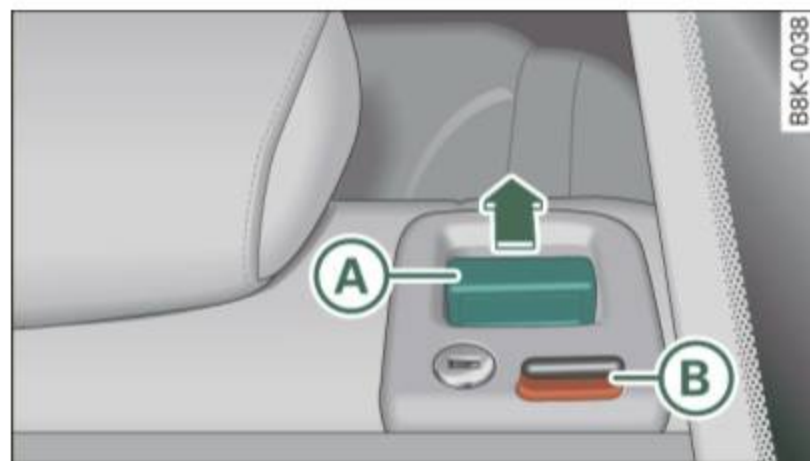



Fig. 93 Release handle on the seat back

Folding the seatback forward

- When you pull the release lever **A** ⇒ fig. 93 in the direction of the arrow, the safety knob **B** pops out far enough for the red marking on knob to be visible.
- Fold the seatback forward.

Raising the seatback

- Raise the seatback until it is securely latched ⇒ . When you can no longer see the red mark on the safety knob **B**, the seat is latched.

The correctly latched seat back (basic position) can be locked and unlocked with the mechanical key at the release handle. This prevents any entry from the vehicle interior into the luggage compartment.

WARNING

The seat back must be securely latched so that objects cannot slide forward out of the luggage compartment during sudden braking.

! Note

Make sure when raising the seatback that the rear safety belts are in the guide so that are not pinched in the seatback lock and damaged. ■

Applies to vehicles: with folding seat back

Locking the seatback



Fig. 94 Locking seat-back

- Turn the mechanical key ⇒ fig. 94 to the right to **lock** the seatback.
- Turn the mechanical key to the left to **unlock** the seat-back.

The correctly latched seat back (basic position) can be locked and unlocked with the mechanical key next to the release handle. This prevents any entry from the vehicle interior into the luggage compartment.

Note

Make sure when raising the seatback that the rear safety belts are in the guide so that they are not pinched in the seatback lock and damaged. ■

Parcel shelf

The parcel shelf behind the rear seat back can be used to carry light items of clothing.

WARNING

No heavy or hard objects should be placed on the parcel shelf. They are a hazard to the vehicle occupants during sudden braking. There is a risk of injury.

Note

Please make sure that the heating wires for the rear window defogger are not damaged by abrasive objects.

Tips

To ensure problem-free ventilation, the ventilation slots between the rear window and the parcel shelf must not be covered. ■

Applies to vehicles: with pass through

Trunk pass-through

The ski sack can be carried in the interior with the help of the pass-through.

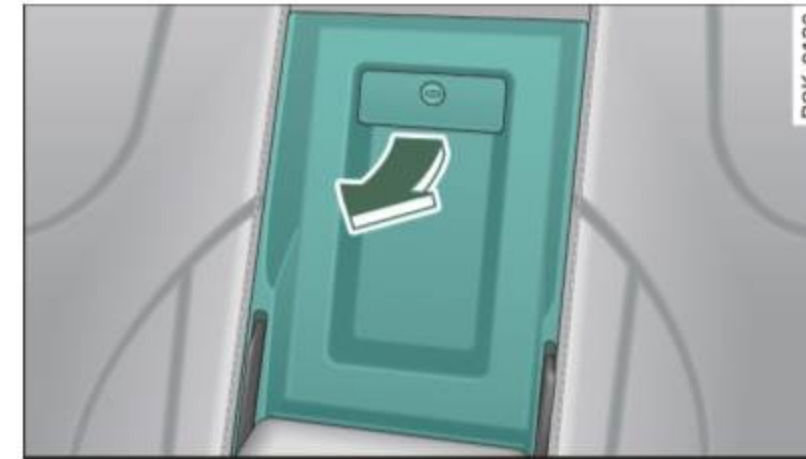


Fig. 95 In the rear seat bench: Opening the pass-through

Opening the trunk pass-through

- Fold the center arm rest in the rear forward and out.
- Pull the release handle ⇒ fig. 95 -Arrow- and fold down the cover of the pass-through in the vehicle interior.
- Open the rear lid.
- Push the ski sack through the opening from the luggage compartment.
- Secure the ski sack ⇒ page 92.

Closing the trunk pass-through

- Open the rear lid.
- Remove the ski sack from the trunk pass-through.
- Push the pass-through cover up inside the vehicle until it latches.
- Raise the center armrest in the vehicle again. ►

- Close the rear lid.

WARNING

Objects must only be transported in the ski sack since the ski sack can be secured. Individual objects cannot be secured. There is a risk of injury.

Tips

- You can open the pass-through from the luggage compartment. Push the release button down and push the cover forward.
- The pass-through can be locked and unlocked with the vehicle mechanical key ⇒ *page 91*, fig. 95. ■

Applies to vehicles: with pass-through

Securing the ski sack

The ski sack must be secured in the luggage compartment.

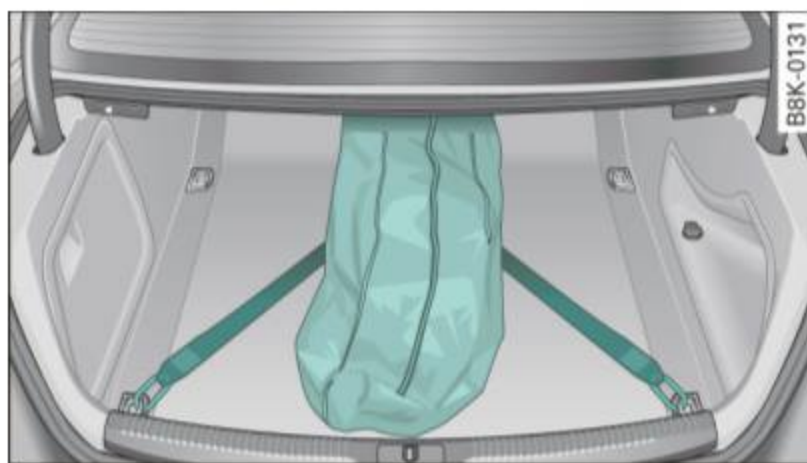


Fig. 96 Luggage compartment:
Securing the bag

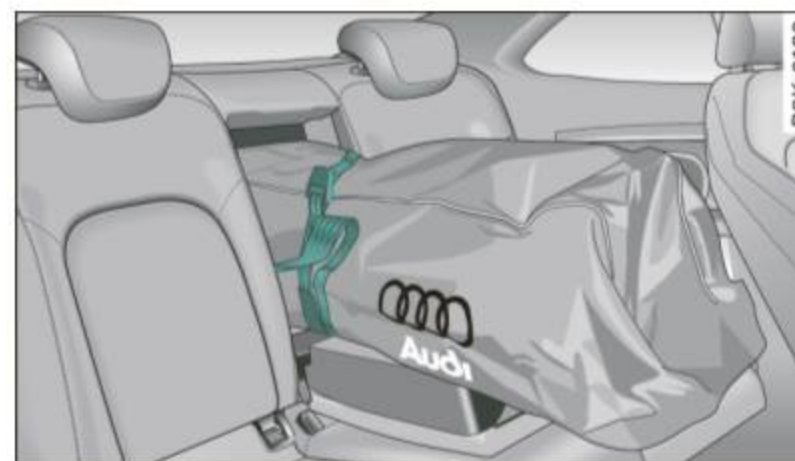


Fig. 97 Securing the objects in the ski sack

Securing the ski sack in the luggage compartment

- The ski sack has two belts with hooks on the underside. Hang the hooks to the rear fastening eyelets in the luggage compartment ⇒ fig. 96.

Securing the objects in the ski sack

- Pull the safety belt taut ⇒ fig. 97 at the free end of the belt.

Tips

Make sure that the ski sack is not stored wet. ■

Roof rack

Description

Additional cargo can be carried with a roof luggage rack.

If luggage or cargo is to be carried on the roof, you must observe the following:

- Your vehicle has aerodynamic rain gutters molded into the roof. This is why conventional roof luggage racks cannot be used. We ►

recommend using roof racks from the Audi original accessories program.

- These roof racks are the basis for a complete roof rack system. For safety reasons, some additional attachments are necessary to transport luggage, bicycles, surf boards, skis and small boats safely. All these components are available at your authorized Audi dealer.

Note

If you use other roof luggage rack systems or do not install the racks as intended, any damage to the vehicle is not covered by the warranty. Carefully follow the assembly and installation instructions included with the roof rack carrier system. ■

Mounting points

The roof rack must be attached only at the locations marked.

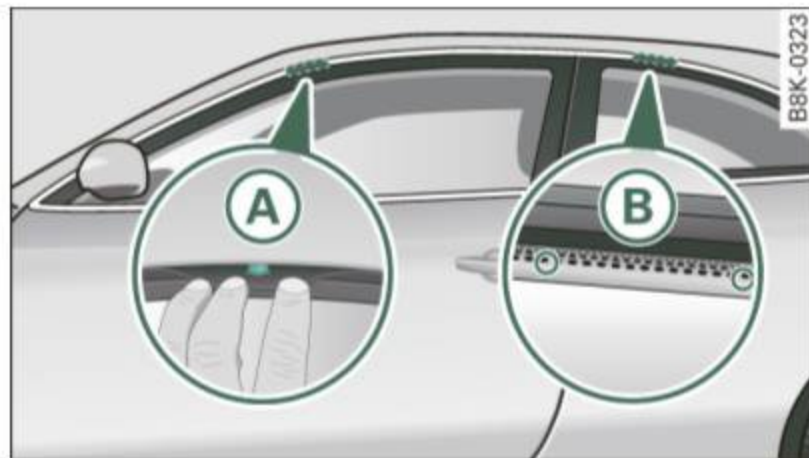


Fig. 98 Mounting locations for roof rack

Installation

When installing the front feet, make sure that they are positioned exactly on the positioning bolts provided (A) between the side panel and the upper roof frame ⇒ fig. 98. The bolt is visible as soon as you push back the seal from the upper roof frame using the installation tool supplied with the roof rack. The rear markings (B) are identified at the upper edge of the side glass by two small arrowheads. ■

Roof load

The cargo on the roof must be securely attached. Handling characteristics change when cargo is transported.

The permissible roof load for your vehicle is **165 lb (75kg)**. The roof load is a combination of the weight of the carrier system and the cargo.

When using roof rack systems with a lower load capacity, you cannot use the maximum permissible roof load. In this case, the roof rack can only be loaded to the weight limit given in the installation guide.

WARNING

- The cargo must be securely attached on the roof rack, otherwise you risk an accident.
- You must under no circumstances exceed the permissible roof load, the permissible axle loads and the permissible overall weight of your vehicle - risk of an accident.
- Consider that when transporting heavy objects or one with a large surface, the handling characteristics change due to shift in the center of gravity or the greater surface exposed to the wind. So adapt your driving and your speed to prevailing conditions.

For the sake of the environment

As a result of the increase wind resistance created by a roof rack, your vehicle is using fuel unnecessarily. So remove the roof rack after using it. ■

Beverage holders

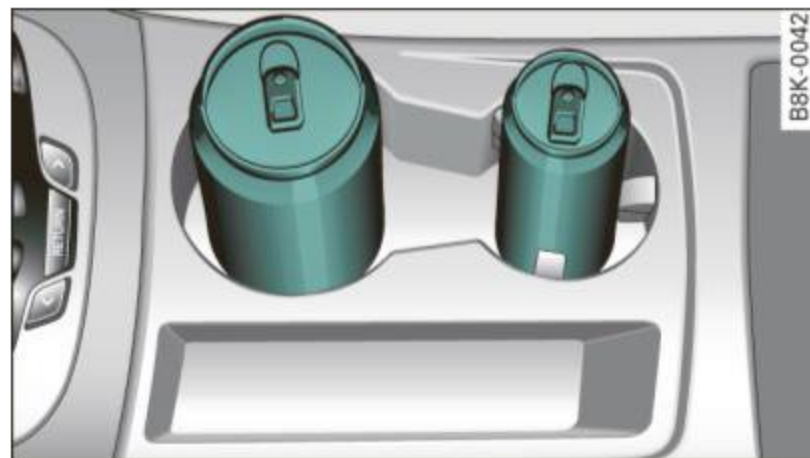


Fig. 99 Center console: Front beverage holders

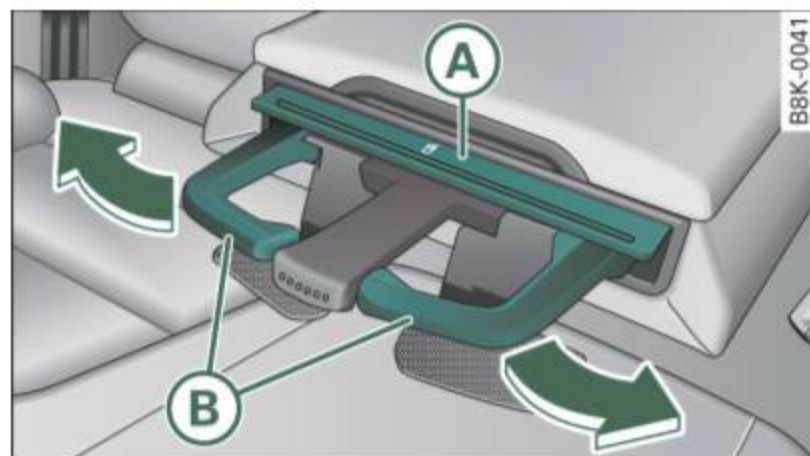


Fig. 100 Beverage storage in the rear arm rest

Front beverage holders

- You can accommodate two beverages in this storage ⇒ fig. 99.

Opening rear beverage holders

- Press on the symbol  (A) ⇒ fig. 100.

Holding beverages at the rear

- To adjust the arm (B), swing it in the direction of the arrow.

- Place the beverage in the holder and release the arm. The arm swings back by itself and automatically secures the beverage.

Closing cup holders

- Press on the center section between the two arms and push the cup holder in the slot as far as it will go.

The holding arm must be adjusted such that it lies closely against the cup holder.

A maximum of two beverages can be placed in the center arm rest.

WARNING

Spilled hot liquid can cause an accident and personal injury.

- Never carry any beverage containers with hot liquids, such as hot coffee or hot tea, in the vehicle while it is moving. In case of an accident, sudden braking or other vehicle movement, hot liquid could spill, causing scalding burns. Spilled hot liquid can also cause an accident and personal injury.
- Use only soft cups in the cupholder. Hard cups and glasses can cause injury in an accident.
- Never use the cupholder or adapter as an ashtray - risk of fire.

Note

Only drink containers with lids should be carried in the cupholder. Liquid could spill out and damage your vehicle's electronic equipment or stain the upholstery, etc. ■

Ashtrays

Front ashtray

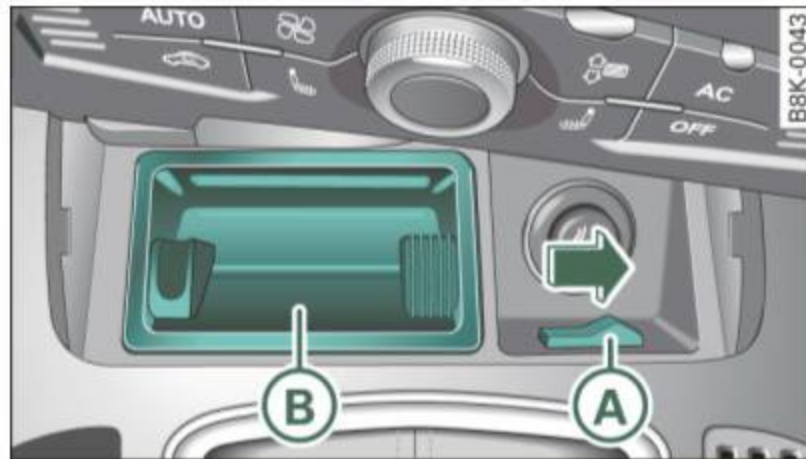


Fig. 101 Center console: front ashtray

Opening the ashtray

- Slide the cover open.

Closing the ashtray

- Tap the lid to close the ashtray automatically.

Removing ashtray insert

- Release the ashtray insert by sliding the switch (A) ⇒ fig. 101 to the right.
- Remove the ashtray insert (B) ⇒ fig. 101.

Reinstalling ashtray insert

- Press the ashtray insert into its holder.

WARNING

Never put waste paper in the ashtray. Hot ashes or other hot objects in the ashtray could set waste paper on fire. ■

Rear ashtray

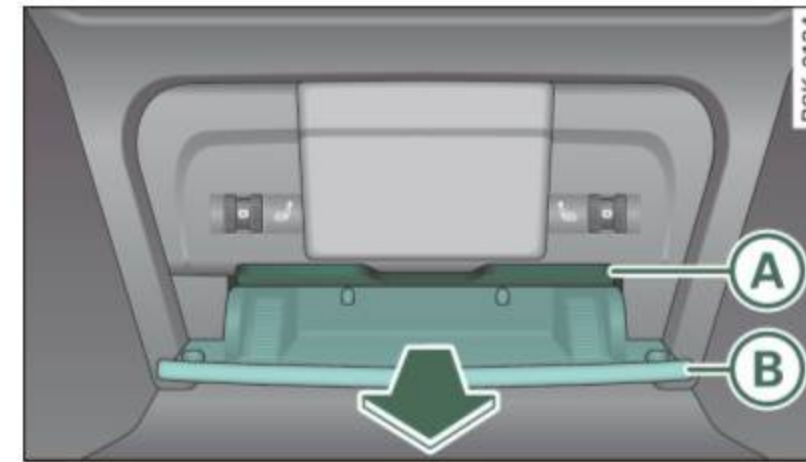


Fig. 102 Rear ashtray

Opening the ashtray

- Pull the ashtray by the rim (B) ⇒ fig. 102 in the direction of the arrow.

Removing ashtray insert

- Press the clip (A) down and remove the ashtray.

Reinstalling ashtray insert

- Install the ashtray insert in its holder.

WARNING

Never put waste paper in the ashtray. Hot ashes or other hot objects in the ashtray could set waste paper on fire. ■

Cigarette lighter/outlet

Cigarette lighter

The socket of the cigarette lighter may be used for 12-volt appliances.



Fig. 103 Open front ashtray

Using the cigarette lighter

- Open the lid of the front ash tray.
- Push the knob on the cigarette lighter in.
- Wait until the knob pops out slightly.
- Remove the cigarette lighter immediately.
- Light your cigarette from the red-hot heating coil of the cigarette lighter.
- Return the cigarette lighter to its socket.

Using the socket

- Removes the cigarette lighter.
- Insert the plug of the electrical device into the cigarette lighter socket.

The socket of the cigarette lighter may be used for 12-volt appliances with maximum consumption of up to 100 watts, such as a flash light, small vacuum cleaner, etc.

Before you purchase any accessories, always read and follow the information in ⇒ page 332, "Additional accessories and parts replacement".

WARNING

- Use care when using the cigarette lighter. Inattentive or unsupervised use of the cigarette lighter can cause burns – risk of injury!
- The cigarette lighter works when the ignition is switched off or with the ignition key removed. Children should never be left unsupervised in the vehicle, or there could be risk of fire!
- The power outlets and therefore the electrical accessories connected to them operate only with the ignition on. Improper use of the outlets or of electrical accessories can lead to serious injuries or cause a fire. For this reason, children should never be left unattended in the vehicle – they could be injured!

Note

To avoid damaging the socket, only use plugs that fit properly.

Tips

With the engine off and accessories turned on, the vehicle battery is discharged. ■

Storage

General overview

There are numerous places to store items in your vehicle.

Glove compartment	⇒ page 97
Storage compartment in the roof	⇒ page 98
Storage compartments in the front seats	⇒ page 98
Coat hooks	⇒ page 98
Storage in the trim panels in the luggage compartment	⇒ page 88

WARNING

- Always remove objects from the instrument panel. Any items not put away could slide around inside the vehicle while driving or when accelerating or when applying the brakes or when driving around a corner.
- When you are driving make sure that anything you may have placed in the center console or other storage locations cannot fall out into the footwells. In case of sudden braking you would not be able to brake, depress the clutch or accelerate.
- Any pieces of clothing that you have hung up must not interfere with the driver's view. The coat hooks are designed only for light-weight clothing. Never hang any clothing with hard, pointed or heavy objects in the pockets on the coat hooks. During sudden braking or in an accident - especially if the airbag is deployed - these objects could injure any passengers inside the vehicle. ■

Glove compartment

The glove compartment is illuminated and can be locked.



Fig. 104 Glove compartment

To open glove compartment

- Pull the handle in the direction of the arrow ⇒ fig. 104 and swing the cover down to open.

To close glove compartment

- Push the glove compartment lid upward until the lock engages.

There are holders for a pen and a pad of paper in the glove compartment lid.

On the right side in the glove compartment is a holder with the key body into which the wallet key must be clipped to be able to start the vehicle.

WARNING

To reduce the risk of personal injury in an accident or sudden stop, always keep the glove compartment closed while driving. ■

Storage compartment in the roof



Fig. 105 Storage pocket in the roof

- To open the lid you have to touch the bar ⇒ fig. 105 (Arrow). The lid opens automatically.
- To close the lid, push it up until it engages.

WARNING

Always keep the lid closed while driving to reduce the risk of injury during a sudden braking maneuver or in the event of an accident. ■

Coat hooks

The coat hooks are located on the side on the pillar in the rear

WARNING

- Make sure that hanging clothing does not obscure the view to the rear.
- Hang only lightweight clothing and be sure that there are no heavy or sharp-edged objects in the pockets.
- Do not use coat hangers to hang the clothing otherwise the efficacy of the head air bags* is compromised. ■

Applies to vehicles: with storage in the front seat

Storage compartment in the front seats

On the face of each of the front seats you will find an opening storage compartment.

Opening

- Pull on the handle to open the compartment.

Closing

- Swing the lid upward until it clicks into place.

Tips

The maximum load is 1 kg. ■

Warm and cold

Deluxe automatic climate control plus

Description

The air conditioner is fully automatic and is designed to maintain a comfortable and uniform climate inside the vehicle.

We recommend the following settings:

- Set the temperature to 75 °F (+23 °C).
- Press the **AUTO** button.

With this setting, you attain maximum comfort in the least amount of time. Change this setting, as desired, to meet your personal needs.

The climate controls are a combination of heating, ventilation and cooling systems, which automatically reduce humidity and cool the air inside your vehicle.

The climate control automatically maintains a temperature once it has been set. The temperature of the air from the vents, fan speed (air volume) and air distribution are also automatically adjusted. The system also takes into account strong sunshine so that manual adjustment is not necessary. So in almost all cases, **automatic mode** offers the best conditions for the comfort of the occupants at all times of the year ⇒ *page 101*.

Please note the following:

Turn on the air conditioner to reduce humidity in the vehicle. This also prevents the windows from fogging up.

When the outside temperature is high and the air is very humid, **condensation** from the evaporator may drip under the vehicle. This is normal and does not indicate a leak.

If the outside temperature is low, the fan normally only switches to a higher speed once the engine coolant has warmed up sufficiently.

The air conditioner temporarily switches off when you drive off from a standstill using full throttle to save engine power.

The compressor also switches off if the coolant temperature is too high, so that the engine can be adequately cooled under extreme loads.

Dust and pollen filter

The dust and pollen filter (a combined particle filter and activated charcoal filter) reduces or prevents outside air pollution (dust, or pollen) from entering the vehicle.

The dust and pollen filter must be changed at the intervals specified in your Maintenance booklet, so that the air conditioner can properly work.

If you drive your vehicle in an area with a high degree of air pollution, the filter may need to be changed more frequently than specified in your Audi Warranty & Maintenance booklet. If in doubt, ask your authorized Audi Service Advisor for advice.

Key recognition

The current climate control settings are automatically stored and assigned to the remote key

Energy management

To prevent the battery from being discharged and to restore the balance of energy, components which require large amounts of energy are temporarily cut back or switched off ⇒ *page 227*.

Heating systems in particular require a great deal of energy. If you notice, for example, that the rear window heater is not heating, then ►

it has been temporarily cut back or switched off by **energy management**. These systems are available again as soon as the energy balance has been restored.

WARNING

Reduced visibility is dangerous and can cause accidents.

- For safe driving it is very important that all windows be free of ice, snow and condensation.
- Completely familiarize yourself with the proper use and function of the heating and ventilation system and especially how to defog and defrost the windows.
- Never use the windshield wiper/washer system in freezing weather until you have warmed the windshield first, using the heating and ventilation system. The washer solution may freeze on the windshield and reduce visibility.

Note

- If you suspect that the climate control system has been damaged, switch the system off to avoid further damages, and have it inspected by a qualified dealership.
- Repairs to the Audi air conditioner require special technical knowledge and special tools. Contact an authorized Audi dealer for assistance.

Tips

- To avoid adversely affecting heating and cooling performance and to prevent condensation on the windows, the air intake in front of the windshield must be free of ice, snow and leaves.
- The air flowing out of the vents and throughout the vehicle's entire interior is discharged at the rear of the vehicle. Make sure that the outlet slots are not covered by clothing, etc.
- Climate control works most effectively if the windows and the panorama/tilting sunroof* are closed. However, if the interior of a

parked vehicle is extremely hot from the sun, briefly opening the windows can speed up the cooling process. ■

Controls










This overview will help you to familiarize yourself with the climate controls.



Fig. 106 Climate controls

The display shows the selected temperature for the driver's side on the left and the selected temperature for the front passenger's side on the right.

Functions are set by rotating the control or are switched on and off by tapping the buttons. The LED in the buttons illuminates when the function is active. ▶

Button(s)	Meaning	Page
	Turns on and off	⇒ page 101
	Automatic operation - driver's side front passenger's side	⇒ page 101
Temperature regulator 1 ^{a)} Temperature regulator 2 ^{a)}	Temperature selection - driver's side Temperature selection - front passenger's side	⇒ page 102
	Fan - driver's side front passenger's side	⇒ page 102
 b)	Recirculation mode	⇒ page 103
 c)	Air distribution - driver's side front passenger's side	⇒ page 103
	Defrost	⇒ page 104
	Rear window defogger	⇒ page 104
	Turns cooling system on and off	⇒ page 104
	Seat heating	⇒ page 107

a) The regulator is also used to set the fan speed, air distribution and seat heating.

b) The symbol may appear slightly different in some models.

c) A seat (instead of an air vent) is displayed in some models.

Tips


- The grille on the controls ⇒ page 100, fig. 106 must remain unobstructed and must not be taped over. Measuring sensors are located behind it. ■

Turning the climate control on and off

Turning the climate control on


- Briefly press , or
- press .

Turning the climate control off

- Press the  button *for at least 2 seconds* to turn the climate control off and to block the air supply from the outside. "OFF" appears in the display.

Climate control turns on again when you press the **temperature regulator**


Tips

With the ignition turned off, you can activate the residual heat function by pressing the  button. The residual heat from the coolant is used to heat the vehicle interior. ■

Automatic mode

The standard operating mode for all times of the year.

Turning on automatic mode

- Set the temperature between 60 °F (+16 °C) and 84 °F (+28 °C).
- Press .

Automatic mode ensures constant temperatures in the interior and dehumidifies the air inside the vehicle. Air temperature, volume and distribution are controlled automatically to reach or maintain the desired interior temperature as quickly as possible. Fluctuations in ►

exterior temperature and the effects of temperature from the position of the sun are compensated for automatically.

This operating mode works only in an adjustable temperature range of 60 °F (+16 °C) to 84 °F (+28 °C). If a temperature below 60 °F (+16 °C) is selected, **LO** appears in the display. At temperatures above 84 °F (+28 °C), **HI** is displayed. At both extreme settings, climate control runs continuously at maximum cooling or heating power. There is no temperature regulation. ■

Setting the temperature

The temperature can be set separately for the driver's side and front passenger's side.



Fig. 107 Temperature setting regulator

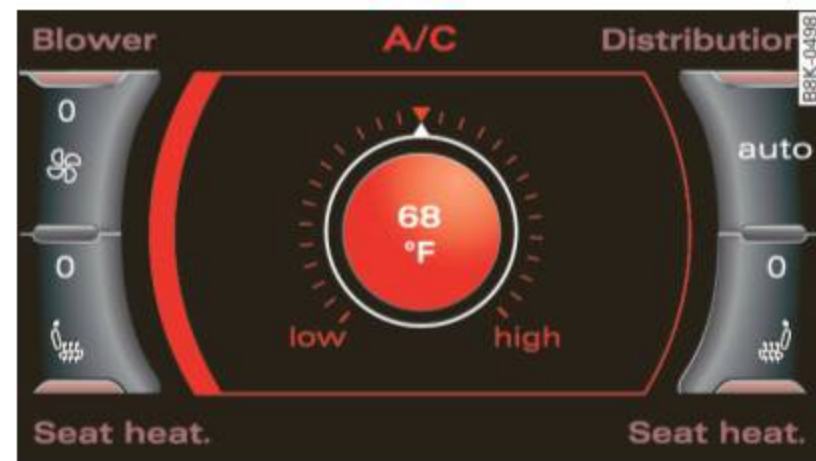


Fig. 108 MMI display: Setting the temperature

- Rotate the regulator to the left to reduce the temperature, or to the right to increase the temperature
⇒ fig. 107.

The selected temperature appears on the climate control display. When the MMI display is turned on, the temperature setting appears for a few seconds on the screen ⇒ fig. 108. ■

Fan

The automatically preset fan speed can be reduced or increased.



Fig. 109 Fan button and regulator

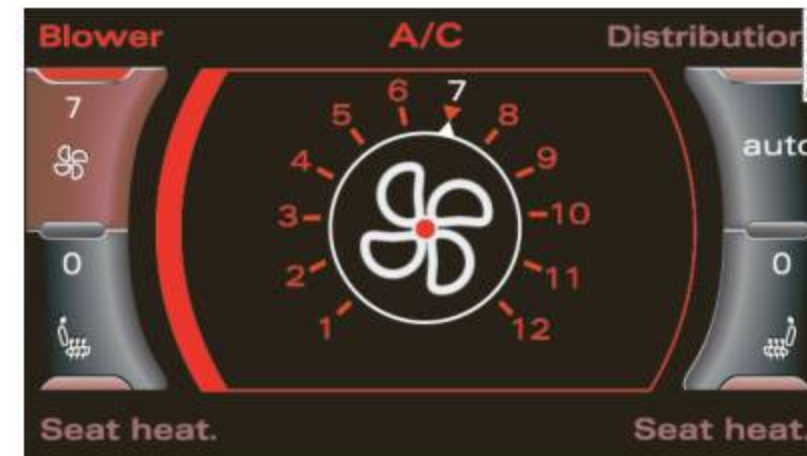


Fig. 110 MMI display: Setting the fan

- Press the **Fan**  button.

- Rotate the regulator to set the desired fan speed (air volume).

The climate control system automatically regulates fan speed based on the interior temperature. You can adjust the volume of air produced by the fan to your own requirements.

When the MMI display is turned on, the fan speed setting appears for a few seconds on the screen ⇒ *page 102*, fig. 110.

Tips

- It is possible that the fan speed may change automatically. This occurs to ensure that the desired temperature setting is reached as quickly as possible.
- The fan speed cannot be regulated separately for the driver and front passenger. ■

Recirculation mode

The recirculation mode prevents polluted outside air from entering the vehicle interior.

Turning on recirculation mode

- Press the  ⇒  button.

Turning off recirculation mode

- Press the  button again, or
- press the **AUTO** button, or
- press the  button.

In recirculation mode, air is drawn from the vehicle interior, filtered and recirculated. We recommend selecting recirculation mode under the following conditions:

When driving through a tunnel or in a traffic jam so that exhaust fumes and odors cannot enter the vehicle interior.

WARNING

You should not use the recirculation mode for an extended period since no fresh air is drawn in. With the air-conditioning switched off, the windows can fog up, which increases the risk of an accident! ■

Air distribution

The automatically preset air distribution can be changed.



Fig. 111 Air distribution button and regulator

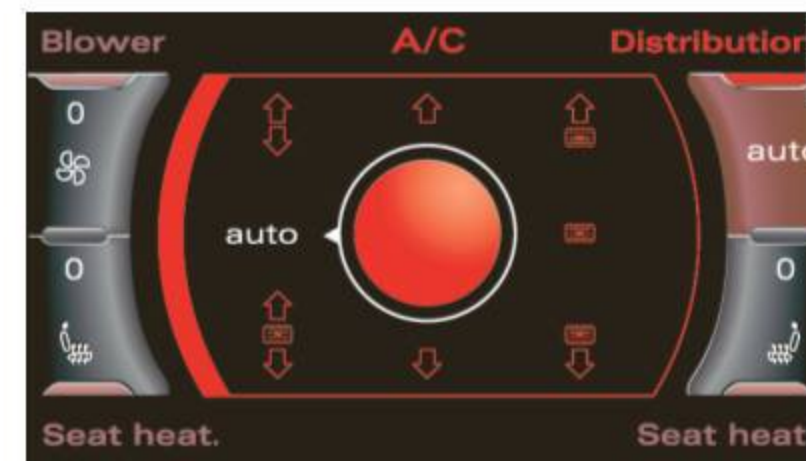





Fig. 112 MMI display: Air distribution

- Press the **Distribution**  button. 

- Rotate the regulator to the desired setting.



You can adjust the air distribution so that air flows from specific vents. In position  air flows only to the windows, in position , it flows to the driver or passenger, and in position  it flows to the footwell. There are additional combinations available to adjust air distribution as needed.

To regulate air distribution automatically, switch to **AUTO**.

When the MMI display is turned on, the air distribution setting appears for a few seconds on the screen ⇒ *page 103, fig. 112.* ■

Defrost

The windshield and side windows are defrosted or cleared of condensation as quickly as possible.


- Press  to turn on the defroster.
- Press the  button again, or press the **AUTO** button to turn it off.

Temperature is controlled automatically. The maximum amount of air flows mainly from the vents below the windshield.

Pressing the  button switches off recirculation mode. ■


Rear window defogger

The rear window defogger clears the rear window of condensation.

- Press the  button to turn the rear window defogger on and off.

The rear window defogger works only when the engine is running. The indicator light in the button illuminates when the rear window defogger is on.

The rear window defogger is switched off automatically after 10 to 20 minutes, depending on the outside temperature.

The rear window defogger can be turned on permanently by pressing the  button for more than two seconds. This remains stored until the ignition is switched off. A rear window defogger that was switched on also remains stored for 15 minutes after the ignition is switched off.

If the engine is restarted within these 15 minutes, the rear window defogger is activated for 10 to 20 minutes, depending on outside temperature. When a vehicle is parked for a short time, the rear window defogger does not need to be manually activated again.



For the sake of the environment

As soon as the rear window is clear, you should switch the rear window defogger off. The reduced power consumption has a beneficial effect on fuel consumption. ■

A/C mode **A/C**

Turning A/C off

- Press the **A/C** button.

Turning A/C on

- Press the **A/C** button again.

The cooling system is turned on in A/C mode. The heating and ventilation system is controlled automatically.



Tips

If the LED in the switch does not illuminate after A/C mode has been turned on (= turning the A/C off), there is a fault in an air-conditioning component. Please consult a authorized dealership if there is an operating problem. ■

Air vents

Air distribution determines the air flow from the individual vents.

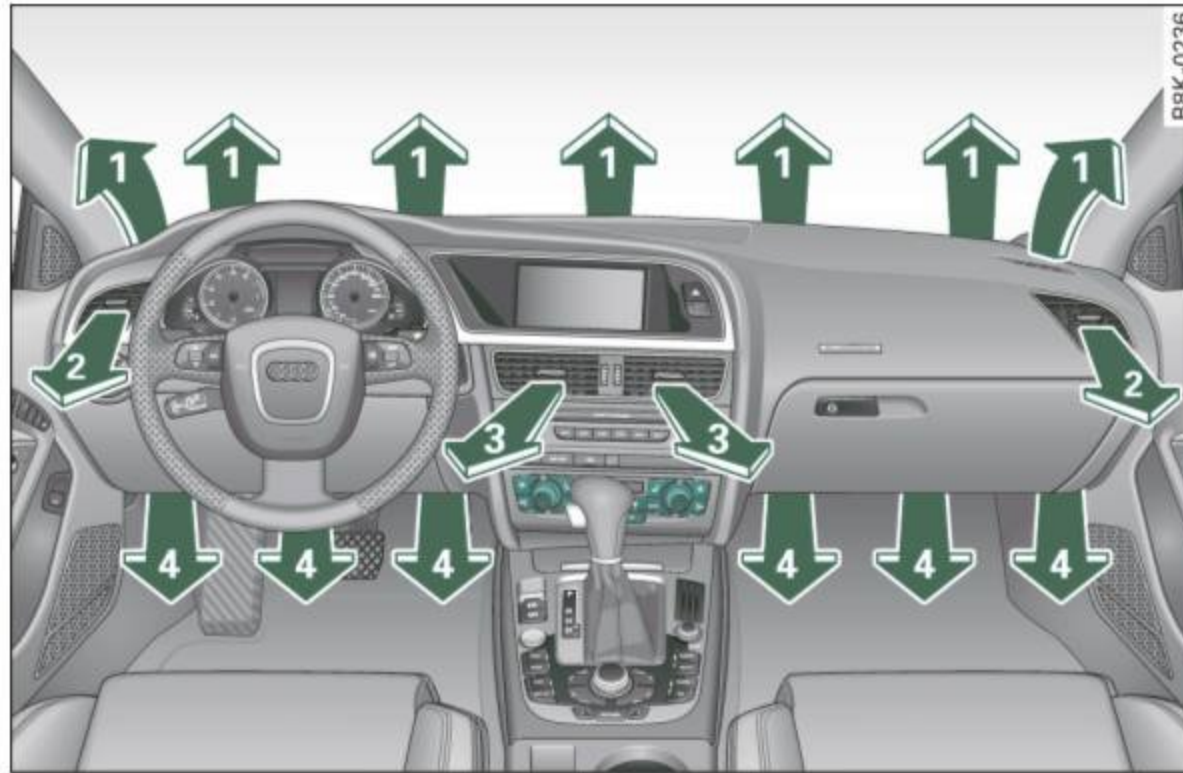


Fig. 113 Instrument panel: Location of air vents

Vents ② and ③

- Rotate the thumbwheel located next to the outlet to open or close it.
- To adjust the direction of the airflow from the outlet, move the tab in the center of the outlet in the desired direction. The direction of the air delivered from the vents can be adjusted horizontally and vertically.

The air outlets are actuated either automatically or manually depending on the operating mode selected. Heated or unheated fresh air or cooled air flows from vents ① through ④.

i Tips

If the climate control is running in cooling mode, air flows mainly from vents ② and ③. To achieve adequate cooling, you should never close these vents completely. ■

Rear air vents

The rear air vents are located in the center console.

- Rotate the thumbwheel to open and close the vents.
- To adjust the direction of the airflow from the outlet, move the tab in the center of the outlet in the desired direction. The direction of the air delivered from the vents can be adjusted horizontally and vertically.

The air vents are actuated either automatically or manually depending on the operating mode selected. Heated or unheated fresh air, or cooled air flows from the vents.

The air vents to heat the rear footwell are located under the front seats.

i Tips

If the climate control is operating in cooling mode, air flows primarily from the vents in the center console. To achieve adequate cooling, you should never close these vents completely. ■

Economical use of the climate control system

Economical use of the climate control system helps save fuel.

When the climate control system is working in cooling mode, engine performance is reduced and fuel consump- ▶

tion is affected. To keep the time the climate control system is on as short as possible, you should do the following:

- To save fuel, turn off cooling mode by pressing the A/C button (indicator light goes out).
- In addition, if you open the window or the panorama/tilting sunroof* while driving, turn off cooling mode by pressing the A/C button (indicator light goes out).
- If the vehicle is extremely hot due to the heat of the sun, briefly open doors and windows.



For the sake of the environment

When you save fuel, you reduce emissions from the vehicle. ■

Deluxe automatic climate control plus - basic settings

General information

The basic climate control settings can be adjusted in the radio or MMI.*

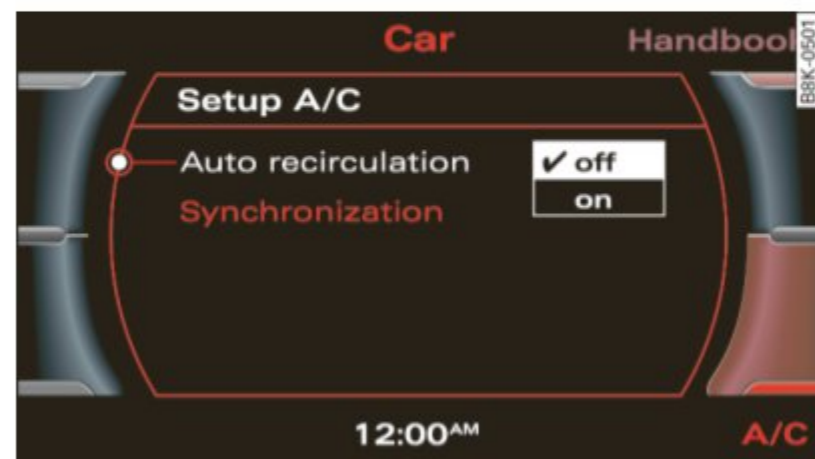


Fig. 114 MMI display: Setup climate control

- Select: Function button **CAR** > Climate control switch.

The following functions can be selected:

- Automatic recirc. ⇒ page 106
- Synchron. ⇒ page 107 ■

Automatic recirculation

An air quality sensor detects increased concentrations of pollutants in the outside air and automatically switches to recirculation mode.

We recommend that you always keep automatic recirculation ON to prevent polluted outside air from entering the vehicle interior.

If the **air quality sensor** located in the climate control system detects polluted outside air, the sensor decides whether the air pollution can be reduced by the factory-installed pollutant filter or whether it is necessary to switch to recirculation. With heavy concentrations of pollutants, the climate control system is switched automatically to recirculation mode and the supply of outside air is blocked. As soon as the concentration of pollutants in the outside air drops, fresh air is supplied to the vehicle interior again.

In the event that the windows fog up during automatic recirculation, press the button immediately.

Under certain operating conditions, automatic recirculation is switched off automatically. When outside temperatures are below about 50 °F (+10 °C), automatic recirculation is limited to 30 seconds. When outside temperatures are below about 30 °F (-1 °C), automatic recirculation is limited to 15 seconds. ■

Synchronization

One climate control setting for all seats.

After Synchronization is set to **on**, all of the subsequent climate control settings (except for seat heating*) for the driver are transferred to the front passenger.

Synchronization is canceled when settings are adjusted on the front passenger's side. ■

Seat heating

Applies to vehicles: with front seat heating

Front seat heating

The seat cushion and the seat back of the front seats can be heated electrically.

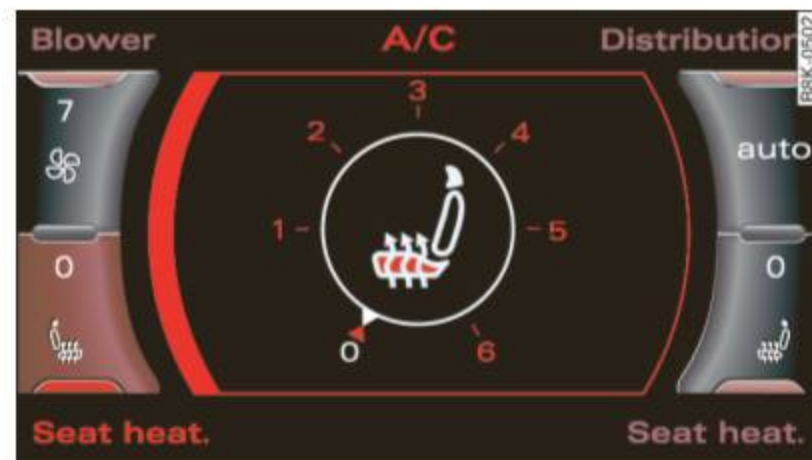



Fig. 115 MMI display: Seat heating

- Press the seat heating  button.
- Rotate the regulator to the desired setting.

In position 0, seat heating is turned off. The control range is from 1 to 6.

When the MMI display is turned on, the seat heating setting appears for a few seconds on the screen ⇒ fig. 115.

Note

To avoid damage to the heating elements in the seats, do not kneel on the seats or place heavy loads on a small area of the seat. ■

Applies to vehicles: with seat ventilation (still in process at time of printing)

Seat ventilation

The seat cushion and the seat back for the front seats can be ventilated.

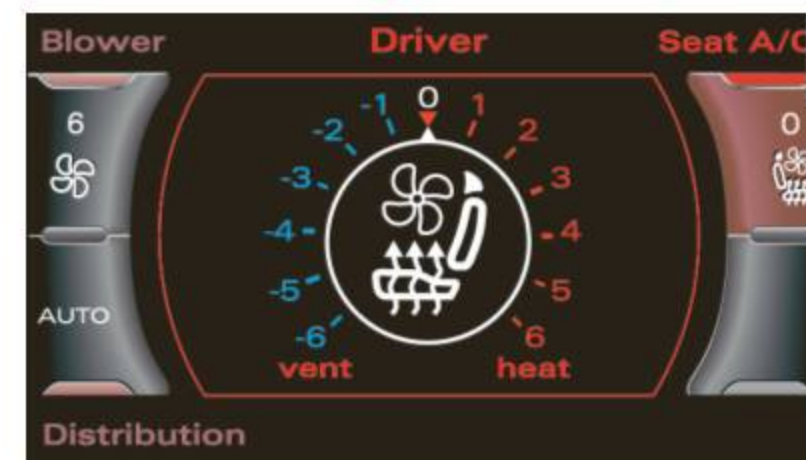



Fig. 116 MMI display: Seat ventilation

- Press the **Seat air-conditioning**  control button.
- To set seat ventilation, rotate the control knob to the left to the desired strength.
- To set seat heating, rotate the control knob to the right to the desired strength.

In position 0, seat ventilation and heating are turned off. ■

On the road

Steering

Applies to vehicles: with manually adjustable steering wheel

Manually adjusted steering wheel

The height and reach of the steering wheel can be adjusted.

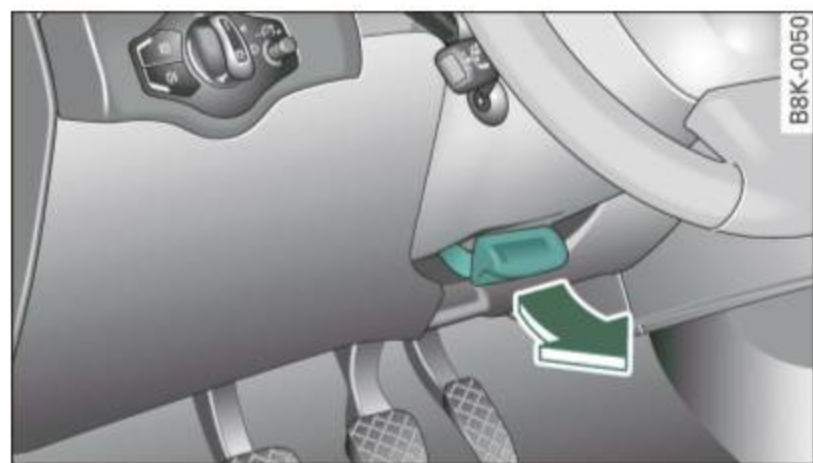


Fig. 117 Lever under the steering column

First, adjust the driver's seat correctly.

- Pull the lever ⇒ fig. 117 -Arrow- ⇒ ⚠.
- Move the steering wheel to the desired position.
- Push the lever against the steering column until it locks.

There must be at least 10 inches (25 cm) between your chest and the center of the steering wheel. If you cannot sit more than 10 inches (25 cm) from the steering wheel, see if adaptive equipment is available to help you reach the pedals and increase the distance from the steering wheel.

For detailed information on how to adjust the driver's seat, see ⇒ page 81.

The steering wheel can be adjusted even when the ignition is turned Off. For vehicles with seat memory, the individual positions for the steering wheel can be stored along with the seat position.

⚠ WARNING

Improper use of steering wheel adjustment and improper seating position can cause serious personal injury.

- **Adjust the steering wheel column only when the vehicle is not moving to prevent loss of vehicle control.**
- **Adjust the driver's seat or steering wheel so that there is a minimum of 10 inches (25 cm) between your chest and the steering wheel ⇒ page 154, fig. 158. If you cannot maintain this minimum distance, the airbag system cannot protect you properly.**
- **If physical limitations prevent you from sitting 10 inches (25 cm) or more from the steering wheel, check with your authorized Audi dealer to see if adaptive equipment is available.**
- **If the steering wheel is aligned with your face, the supplemental driver's airbag cannot provide as much protection in an accident. Always make sure that the steering wheel is aligned with your chest.**
- **Always hold the steering wheel with your hands at the 9 o'clock and 3 o'clock positions to reduce the risk of personal injury if the driver's airbag deploys.**
- **Never hold the steering wheel at the 12 o'clock position or with your hands inside the steering wheel rim or on the steering wheel hub. Holding the steering wheel the wrong way can cause serious injuries to the hands, arms and head if the driver's airbag deploys. ■**

Ignition lock and ignition switch

Starting engine with the key

The ignition is switched on and the engine started with the ignition key.

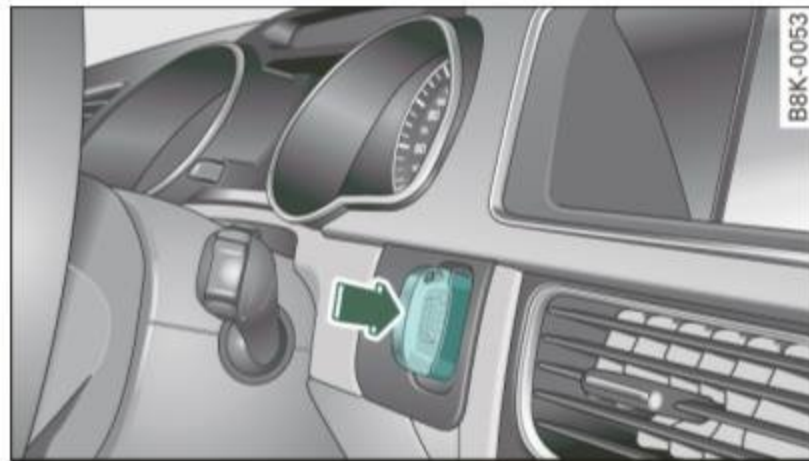


Fig. 118 Ignition key

- Insert the key into the ignition lock.
- *Manual transmission:* Fully depress the clutch pedal and move the shift lever to the neutral position.
- *Automatic transmission:* Step on the brake pedal and move the selector lever to the P or N position.
- **Press** the key ⇒ fig. 118 - the engine will start.

By pressing the key **without** without stepping on the clutch or the brake, the ignition is switched on and off. With the ignition on, the steering wheel is unlocked.

You can only remove the key with the ignition switched off. To do this, you have to press on the key again. With an automatic transmission, the selector lever must be in the P position.

When starting the engine, major electrical loads are switched off temporarily.

After starting a cold engine, there may be a brief period of increased noise because the oil pressure must first build up in the hydraulic valve adjusters. This is normal and not a cause for concern.

If the engine should not start immediately, the starting process is automatically stopped after a short time. Repeat starting procedure.

Driver message in the instrument cluster display

Press brake pedal to start engine

This message appears if you do not step on the brake pedal to start the engine on a vehicle with an automatic transmission.

Press clutch pedal to start engine

This message appears if you do not step on the clutch pedal to start the engine on a vehicle with a manual transmission.

Engage N or P to start engine


This message appears when the engine is started if the selector lever for the automatic transmission is not in the P or N position. The engine can only be started with the selector in these positions.

Shift to P, otherwise vehicle can roll away. Doors do not lock if lever is not in P.

This message appears for safety reasons along with a warning signal. It appears if the selector lever for the automatic transmission is not in the P position after the ignition is switched off. Move the selector lever to the P position, otherwise the vehicle is not secured against rolling away. You also cannot lock the vehicle using the locking button on the door handle or using the remote key.

WARNING

- **Always take the key with you whenever you leave your vehicle. Otherwise, the engine could be started or electrical equipment such as the power windows could be operated. This can lead to serious injury.**

 **WARNING** (continued)

- **Never leave children or persons requiring assistance unattended in the vehicle. The doors can be locked using the remote transmitter, preventing people from escaping from the vehicle on their own in the event of an emergency. Depending on the time of year, people inside the vehicle can be exposed to very high or very low temperatures.**
- **Never remove the ignition key from the ignition lock while the vehicle is moving. Otherwise, the steering lock could suddenly engage and you would not be able to steer the vehicle.**

 **Note**

- In the event of a malfunction in the electronic ignition lock a symbol in the instrument cluster flashes with the message **Ignition lock defective**.
- Avoid high engine speeds, fast acceleration or heavy engine loads while the engine is still cold. This could damage the engine.

 **For the sake of the environment**

To avoid unnecessary engine wear and to reduce exhaust emissions, do not let your vehicle stand and warm up. Be ready to drive off immediately after starting your vehicle. Maintain moderate speed until the engine is completely warm. Remember, the engine performs best at operating temperature.

 **Tips**


- If the key cannot be removed from the ignition lock, you have to pull the mechanical key out of the master key in order to be able to lock the vehicle. The vehicle can be locked with the mechanical key ⇒ *page 48*.
- If you open the driver's door with the ignition switched on, a buzzer sounds and the message **Ignition is on** appears in the instrument cluster display. Switch the ignition off. ■

Stopping the engine

- Bring the vehicle to a full stop.
- Automatic transmission: Move the selector lever to the P or N position.
- **Press** on the ignition key. The engine is turned off.

Emergency off

If it is necessary in unusual circumstances, the engine can be switched off while the vehicle is moving. The engine will be switched off if you press on the key for an extended period.

 **WARNING**

- **Never turn off the engine until the vehicle has come to a complete stop.**
- **The brake booster and servotronic only work when the engine is running. With the ignition turned off, you have to apply more force when steering or braking. Since you cannot steer and stop normally, this can lead to accidents and serious injuries.**
- **The radiator fan can continue to run for up to 10 minutes even after you have turned off the engine and removed the ignition key. The radiator fan can also turn on again if the engine coolant heats up because of intense sunlight or heat build-up in the engine compartment.**

 **Note**

Do not stop the engine immediately after hard or extended driving. Keep the engine running for approximately two minutes to prevent excessive heat build-up. ■

Starting and stopping the engine with advanced key


Applies to vehicles: with advanced key

Starting the engine with the **START ENGINE STOP** button

This button switches on the ignition and starts the engine.



Fig. 119 Advanced key: START ENGINE STOP button

- *Manual transmission:* Fully depress the clutch pedal and move the shift lever to the neutral position.
- *Automatic transmission:* Step on the brake pedal and move the selector lever to P or N ⇒ .
- **Press** on the **START ENGINE STOP** button ⇒ fig. 119 - the engine will start.

By pressing the **START ENGINE STOP** button without depressing the clutch or the brake pedal, the ignition is switched on and switched off by pressing it again.

If the engine does not start immediately, stop trying after 10 seconds and then try to restart the engine about 30 seconds later.

After a cold engine is started, there may be a brief period of increased noise because oil pressure must first build up in the

hydraulic valve adjusters. This is normal and not a cause for concern.

Driver message in the instrument cluster display

No key identified

This message appears when the **START ENGINE STOP** button is pressed if there is no master key inside the vehicle or if the system does not recognize it. For example, the master key cannot be recognized if it is covered by an object (e.g. aluminum brief case) which screens the radio signal. Electronic devices such as cell phones can also interfere with the radio signal.

Press brake pedal to start engine

This message appears if you press the **START ENGINE STOP** button to start the engine and do not depress the brake pedal. The engine can only be started if the brake pedal is depressed.


Press clutch pedal to start engine


This message appears with a manual transmission when you press the **START ENGINE STOP** button to start the engine and do not depress the clutch pedal. The engine can only be started when the clutch pedal is depressed.

Engage N or P to start engine

This message appears when the engine is started if the selector lever for the automatic transmission is not in the P or N position. The engine can only be started with the selector in these positions.

Key not in vehicle

This message appears along with the  symbol if the master key is removed from the vehicle with the engine running. It is intended to remind you (e.g. when changing drivers) not to continue the journey without the master key.

If the master key is no longer in the vehicle, you cannot switch on the ignition after stopping the engine and you also cannot start the engine again. Moreover, you cannot lock the vehicle from the outside with the key. 

Shift to P, otherwise vehicle can roll away. Doors do not lock if lever is not in P.

This message appears for safety reasons along with a warning signal. It appears if the selector lever for the automatic transmission is not in the P position when switching off the ignition with the **START ENGINE STOP** button. Move the selector lever to the P position, otherwise the vehicle is not secured against rolling away. You also cannot lock the vehicle using the locking button on the door handle or using the remote key.

Advanced key defective ! Use ignition lock

This message appears if the vehicle has to be started not with the **START ENGINE STOP** button but with the ignition key.

WARNING

- **Never allow the engine to run in confined spaces - danger of asphyxiation.**
- **Never turn off the engine until the vehicle has come to a complete stop.**
- **The brake booster and servotronic only work when the engine is running. With the ignition turned off, you have to apply more force when steering or braking. Since you cannot steer and stop normally, this can lead to accidents and serious injuries.**

Note

- Avoid high engine rpm, full throttle and heavy engine loads until the engine has reached operating temperature - otherwise you risk engine damage.
- The engine cannot be started by pushing or towing the vehicle.
- If the engine has been under heavy load for an extended period, heat builds up in the engine compartment after the engine is switched off - there is a risk of damaging the engine. Allow the engine to run at idle for about 2 minutes before switching it off.

Tips

If you open the driver's door with the ignition switched on, a buzzer sounds and the message **Ignition is on** appears in the instrument cluster display. Switch the ignition off. ■

Switching engine off with the **START ENGINE STOP button**

- Bring your vehicle to a complete stop.
- Automatic transmission: Move the selector lever to the P or N position.
- **Press** the **START ENGINE STOP** button ⇒ *page 111, fig. 119.*

Emergency OFF function

If necessary, the engine can be switched off with the selector lever in the R, D or S positions. To do so, step on the brake pedal and press and hold the **START ENGINE STOP** button (vehicle speed must be less than 6 mph / 10 km/h).

WARNING

- **Never turn off the engine until the vehicle has come to a complete stop.**
- **The brake booster and servotronic only work when the engine is running. With the ignition turned off, you have to apply more force when steering or braking. Since you cannot steer and stop normally, this can lead to accidents and serious injuries.**
- **For safety reasons, you should always park your vehicle with the selector lever in P. Otherwise, the vehicle could inadvertently roll away.**
- **After the engine has been switched off, the radiator fan can continue to run for up to 10 minutes - even with the ignition**

⚠ WARNING (continued)

switched off. It can also switch on again after some time if the coolant temperature rises as the result of a heat buildup or if the engine is hot and the engine compartment is additionally heated by the sun's rays.

! Note

If the engine has been under heavy load for an extended period, heat builds up in the engine compartment after the engine is switched off - there is a risk of damaging the engine. Allow the engine to run at idle for about 2 minutes before switching it off. ■

Electromechanical parking brake

Operation

The electromechanical parking brake replaces the hand brake.

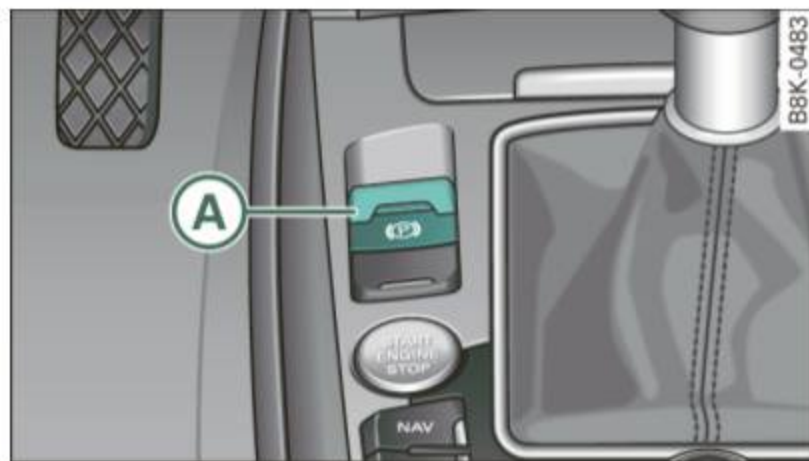


Fig. 120 Center console: Parking brake

- Pull on the switch **(A)** ⇒ fig. 120 to apply the parking brake. The indicator light in the switch illuminates.

- Step on the brake pedal or the accelerator pedal and press the switch at the same time to release the parking brake. The indicator light in the switch goes out.

Your vehicle is equipped with an electromechanical parking brake. The parking brake is designed to prevent the vehicle from rolling unintentionally and replaces the hand brake.

In addition to the normal functions of a traditional hand brake, the electromechanical parking brake provides various convenience and safety functions.

When starting from rest

- The integral starting assist helps you when driving by automatically releasing the parking brake ⇒ page 114, "Starting from rest".
- When starting on inclines, the starting assist prevents the vehicle from unintentionally rolling back. The braking force of the parking brake is not released until sufficient driving force has been built up at the wheels.

Emergency brake function

An emergency brake ensures that the vehicle can be slowed down even if the *normal* brakes fail ⇒ page 115, "Emergency braking".

Indicator lights

- If the parking brake is closed with the ignition **switched on** the indicator lights come on **PARK BRAKE** (USA models) / **(P)** (Canada models) in the instrument cluster and the switch.
- If the parking brake is closed with the ignition **switched off** the indicator lights come on **PARK BRAKE** (USA models) / **(P)** (Canada models) in the instrument cluster and the switch for about 20 seconds.



⚠ WARNING

If a gear or a drive range (automatic transmission) is engaged with the vehicle stationary and the engine running, you must in no

⚠ WARNING (continued)

instance accelerate or release the clutch carelessly. Otherwise the vehicle will start to move immediately - risk of an accident.

! Note

If the symbol  in the display or the indicator light **BRAKE** (USA models)/ (Canada models) in the instrument cluster flashes, there is a malfunction in the brake system. By pressing the **SET** button, you can bring up a driver message which explains the malfunction in more detail. If the driver message **Parking brake!** appears, there is an operating malfunction in the parking brake which you should have repaired immediately by an authorized Audi dealer or other qualified workshop ⇒ *page 33*.

i Tips


- You can apply the parking brake at any time - even with the ignition turned off. The ignition must be turned on in order to release the parking brake.
- Occasional noises when the parking brake is applied and released are normal and are not a cause for concern.
- When the vehicle is parked, the parking brake goes through a self-test cycle at regular intervals. Any associated noises are normal. ■

Parking

Various rules apply to prevent the parked vehicle from rolling away accidentally.

Parking

- Stop the vehicle with the foot brake.
- Pull the switch to apply the parking brake.

- Automatic transmission: Move the selector lever to P.
- Turn the engine off ⇒ .
- Manual transmission: Shift into 1st gear.

In addition on inclines and grades

- Turn the steering wheel so that your vehicle will roll against the curb in case it should start to move.

⚠ WARNING

- **When you leave your vehicle - even if only briefly - always remove the ignition key. This applies particularly when children remain in the vehicle. Otherwise the children could start the engine, release the parking brake or operate electrical equipment (e.g. power windows). There is the risk of an accident.**
- **When the vehicle is locked, no one - particularly not children should remain in the vehicle. Locked doors make it more difficult for emergency workers to get into the vehicle - putting lives at risk. ■**

Starting from rest

The starting assist function ensures that the parking brake is released automatically upon starting.

Stopping and applying parking brake

- Pull the switch to apply the parking brake.

Starting and automatically releasing the parking brake

- When you start to drive as usual, the parking brake is automatically released and your vehicle begins to move. ►

When stopping at a traffic signal or stopping in city traffic on vehicles with an automatic transmission, the parking brake can be applied. The vehicle does not have to be held with the footbrake. The parking brake eliminates the tendency to creep with a drive range engaged. As soon as you drive off as usual, the parking brake is released automatically and the vehicle starts to move.

Starting on slopes

When starting on inclines, the starting assist prevents the vehicle from unintentionally rolling back. The braking force of the parking brake is not released until sufficient driving force has been built up at the wheels.



Tips

For safety reasons, the parking brake is released automatically only when the driver's safety belt is engaged in the buckle. ■

Starting off with a trailer

To prevent rolling back unintentionally on an incline, do the following:

- Keep the switch pulled and depress the accelerator. The parking brake stays applied and prevents the vehicle from rolling backward.
- You can release the switch once you are sure that you are developing enough driving force at the wheels by depressing the accelerator.

Depending on the weight of the rig (vehicle and trailer) and the severity of the incline, you may roll backwards as you start. You can prevent rolling backwards by holding the parking brake switch pulled out and accelerating - just as you would when starting on a hill with a conventional hand brake. ■

Emergency braking

In the event that the conventional brake system fails or locks.

- In an emergency, pull the switch and continue to pull it to slow your vehicle down with the parking brake.
- As soon as you release the switch or accelerate, the braking process stops.

If you pull the switch and hold it above a speed of about 5 mph (8 km/h), the emergency braking function is initiated. The vehicle is braked at all four wheels by activating the hydraulic brake system. The brake performance is similar to making an emergency stop.



In order not to activate the emergency braking by mistake, an audible warning tone (buzzer) sounds when the switch is pulled. As soon as the switch is released, or the accelerator pedal is depressed, emergency braking stops.

WARNING

Emergency braking should only be used in an emergency, when the normal foot brake has failed or the brake pedal is obstructed. Using the parking brake to perform emergency braking will slow your vehicle down as if you had made a full brake application. The laws of physics cannot be suspended even with ESP and its associated components (ABS, ASR, EDS). In corners and when road or weather conditions are bad, a full brake application can cause the vehicle to skid or the rear end to break away - risking an accident. ■

Driver messages in the instrument cluster

Warning Vehicle incline is excessive

This message appears when the parking brake is applied on an incline that exceeds about 30%.

In this case the braking power of the parking brake may **not be adequate** to prevent the vehicle from rolling unintentionally.


Please release parking brake

Please note that for safety reasons the parking brake is released automatically only if the driver's seat belt is fully engaged in the buckle.

To release the parking brake press the brake pedal

This driver message appears when the switch to release the parking brake was pressed. The parking brake can only be released if you step on the brake pedal and at the same time press the switch or you automatically release the parking brake with the starting assist ⇒ *page 114*.

Parking brake!

This driver message appears together with the yellow  symbol when there is a parking brake malfunction.

Malfunction starting assist

This driver message appears if there is a starting assist malfunction. The automatic release of the parking brake when starting is malfunctioning. You have to release the parking brake manually by pressing the switch. Have the problem corrected by an authorized Audi dealer. ■

Cruise control

Applies to vehicles: with cruise control

Switching on

The cruise control system makes it possible to drive at a constant speed starting at 20 mph (30 km/h).

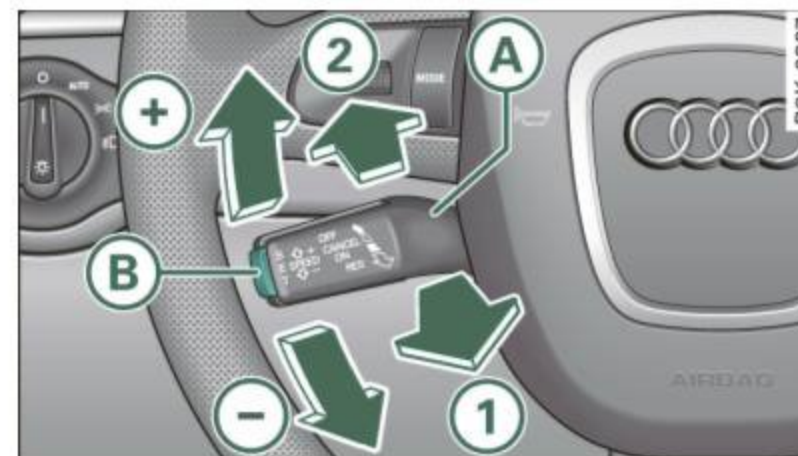


Fig. 121 Control lever with push-button

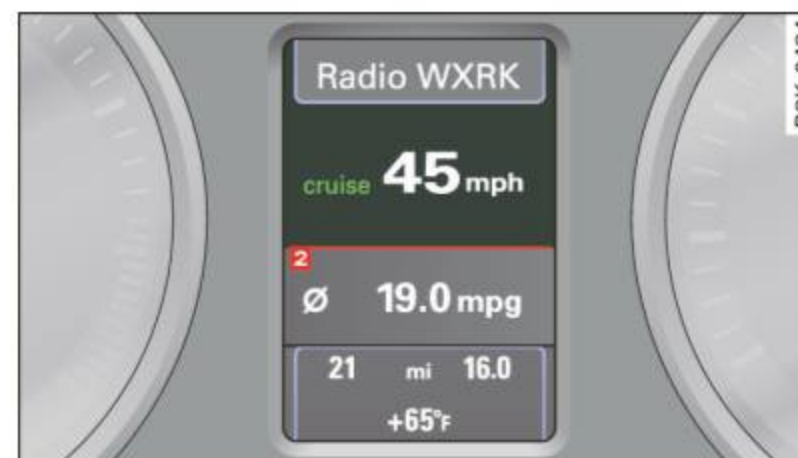




Fig. 122 Display: Selected speed

- Pull the lever **A** to position **1** ⇒ fig. 121 to switch the system on.
- Drive at the speed to be controlled.
- Press button **B** to set that speed.



The stored speed and the green symbol **CRUISE** (US model) /  (Canadian model) are shown in the display ⇒ *page 116*, fig. 122. The display may vary, depending on the type of display in your vehicle. The indicator light **CRUISE** (US model) /  (Canadian model) will also light up in the instrument cluster.

The speed is kept constant by modifying engine power or through an active brake intervention.

WARNING

- **Always pay attention to the traffic around you when the cruise control is in operation. You are always responsible for your speed and the distance between your vehicle and other vehicles.**
- **For reasons of safety, cruise control should not be used in the city, in stop-and-go traffic, on twisting roads and when road conditions are poor (such as ice, fog, gravel, heavy rain and hydroplaning) - you could have an accident.**
- **Switch the cruise control off temporarily when driving in turning lanes, highway exits or in construction zones.**
- **Please note that unconsciously "resting" your foot on the accelerator pedal causes cruise control not to brake. This is due to the control system being overridden by the driver's acceleration.**

Tips

- Vehicles with manual transmission: You can attain the set speed only if the gear that is currently engaged will allow it, or if it does not tax the engine and allows it to run smoothly. Therefore shift into a higher or lower gear in a timely manner.
- The brake lights illuminate as soon as the brakes apply automatically. ■

Applies to vehicles: with cruise control

Changing speed

- Press the lever **A** in the direction of the **+** ⇒ *page 116*, fig. 121 or in the direction of the **-** to increase or decrease your speed.
- Let go of the lever to save that speed.

Change speed in increments of 1 mph (1 km/h) by lightly pressing the lever. If you keep the lever pressed down, you will alter your speed in 5 mph (10 km/h) increments.

You can also press the accelerator pedal down to increase your speed, e.g. if you want to pass someone. The speed you saved earlier will resume as soon as you let off of the accelerator pedal.

If, however, you exceed your saved speed by 5 mph (10 km/h) for longer than 5 minutes, the cruise control will be turned off temporarily. The green symbol in the display turns white, the saved speed is retained. ■

Applies to vehicles: with cruise control

Pre-selecting speed

You can pre-select your desired speed while the vehicle is not moving.

- Turn on the ignition.
- Pull lever **A** into position 1 ⇒ *page 116*, fig. 121.
- Press the lever in the **+** or **-** direction to increase or decrease your speed.
- Let go of the lever to save that speed. ►

This function makes it possible, for example, to save the speed you want before driving on the highway. Once on the highway, activate the cruise control by pulling the lever toward ①. ■

Applies to vehicles: with cruise control

Switching off

Temporary deactivation

- Step on the brake pedal, or
- Manual transmission: Keep the clutch pedal pressed down *longer*, or
- Press the lever ① into position ② (not clicked into place) ⇒ *page 116*, fig. 121, or
- Drive for longer than 5 minutes at more than 5 mph (10 km/h) above the stored speed.

Switching off completely

- Press lever ① into position ② (clicked into place), or
- Switch the ignition off.

The speed you saved will be retained if the cruise control has been switched off temporarily. To resume the saved speed, let up on the brake or clutch pedal and pull the lever to position ①.

The saved speed will be erased after turning the ignition off.

WARNING

You should only resume the saved speed if it is not too high for existing traffic conditions. Otherwise you risk an accident. ■

Audi side assist

Lane change assistant

Applies to vehicles: with Audi side assist

Description

The side assist helps you when changing lanes.



Fig. 123 Rear bumper: Position of radar sensors (not visible on outside)

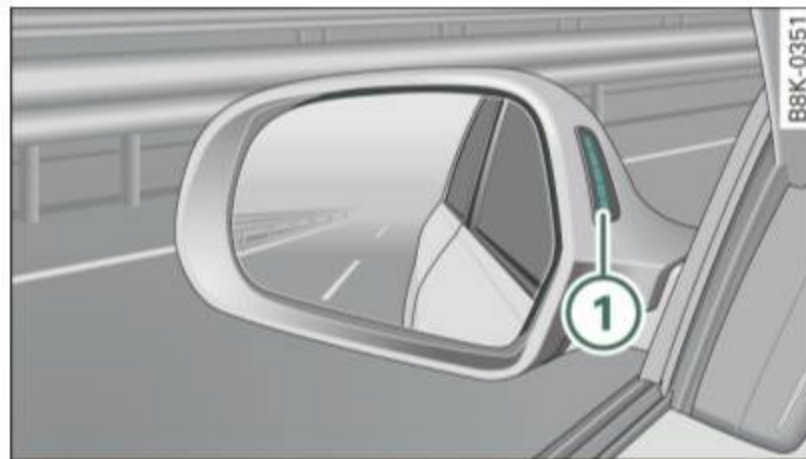


Fig. 124 Signal light on the outside mirror - driver's side

Side assist uses radar sensors (not visible on outside) ⇒ fig. 123 to help the driver check blind spots, and see what is happening in traffic behind the vehicle ⇒ page 121, fig. 126.

Signal lights are built into both outside mirrors ⇒ fig. 124. The signal light on the left outside mirror assists when moving over into

the left lane and the signal light on the right outside mirror assists when moving over into the right lane.

The signal light comes on to tell you that side assist has detected a vehicle on that side and that the position of this other vehicle should be taken into account if you were to change lanes. This is called the **informational stage signal** ⇒ page 121. The informational stage signal is designed so that you notice it only when you are looking in the outside mirror.

When you activate the turn signal and side assist detects a vehicle in a notable location, the corresponding signal on the outside mirror flashes briefly and brightly several times. This is the **alert stage signal** ⇒ page 121. ■

Applies to vehicles: with Audi side assist

Activating and deactivating side assist



Fig. 125 Driver's door: Side assist button

Activating

- Press the ⇒ fig. 125 button. The red indicator on the button lights up.

Deactivating

- Press the button again. The indicator light on the button goes out.

The system can assist when driving on highways and secondary roads. The system works only at speeds faster than 37 mph (60 km/h).

WARNING

- **Improper reliance on the side assist system can cause collisions and serious personal injury:**
 - Never rely only on side assist when changing lanes.
 - Always check rear view mirrors to make sure that it is safe to change lanes.
- **Side assist cannot detect all vehicles under all conditions—danger of accident!**
- **Side assist cannot detect vehicles in time to alert you when they approach from behind at very high speed, or fall drop back very quickly.**
- **The radar sensor's *vision* can be reduced or entirely blocked by rain, snow, and heavy spray. This can result in side assist not adequately detecting vehicles or, in some cases, not detecting them at all. Always keep an eye on the direction you are traveling and the relevant area around the vehicle.**
- **Please note that side assist indicates there are approaching vehicles, or vehicles in your blind spot, only after your vehicle has reached a driving speed of at least 37 mph (60 km/h).**
- **Side assist signal does not work around tight corners (turning radius less than 218 yards, or 200 m).**
- **Side assist is no replacement for the driver's full attention. The driver alone is responsible for lane changes and similar driving maneuvers. Always keep an eye on the direction you are traveling and the relevant area around the vehicle.**

Note

- To ensure that you do not adversely affect side assist, do not block the area on the rear bumper where the radar sensors are located with foreign objects (such as stickers or bicycle racks).
- Make sure that the signal light on the outside mirror is not blocked by stickers or other items.

Tips

- Side assist automatically deactivates if it detects that the radar sensors are blocked ⇒ *page 126*. The indicator light on the button goes out.
- The area on the bumper where the radar sensors are located must consistently remain free of snow, ice, and heavy soiling so that side assist can function properly. Follow the additional notes on ⇒ *page 127*.
- For vehicles with a trailer hitch* that was installed later according to factory specifications, side assist is automatically deactivated as soon as the electrical connection to the trailer electrical socket is made ⇒ *page 126*.
- For vehicles with a trailer hitch that was **not** installed according to factory specifications, switch off the side assist when towing a trailer.
- Additional tinting on the front side windows can make it harder to see and correctly understand the signal light on the outside mirror. ■

Applies to vehicles: with Audi side assist

Sensor detection area

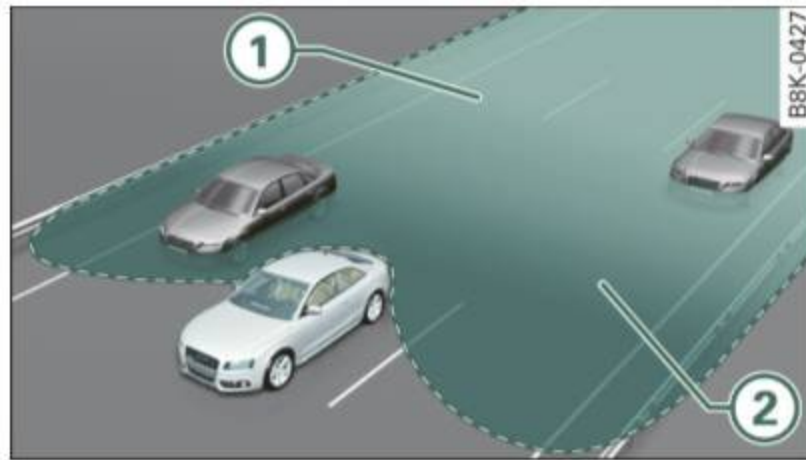


Fig. 126 Schematic illustration: Sensor detection area

The detection ⇒ fig. 126 of the radar sensor detection area is made up of:

- the approach area (light green area) ①, about 55 yards (50 m) behind the vehicle, and
- the “blind spot” (dark green area) ②.

The radar sensors cover the adjacent left and right lanes. Other lanes are *not* covered by the radar sensors.

Tips

Side assist does not measure actual lane width. The system assumes a fixed lane width. Detection in the left and right lanes is based on this assumed lane width. When driving on narrow roads or when driving to the left or right of the center of a travel lane, it is possible that vehicles will be detected that are *not* in the lane next to the lane you are using ⇒ *page 126*. ■

Applies to vehicles: with Audi side assist

Operation

Side assist compares the distance and difference in speed of detected vehicles with the speed of your vehicle. Whenever the difference in speed and distance is registered as notable if you were to change lanes, a signal light appears on the respective mirror.

The signal can light up if you are passed by a vehicle or if you are passing another vehicle.

If you pass another vehicle slowly (difference in speed less than 9 mph, or 15 km/h), the signal light will come on as soon as the other vehicle is in your blind spot and is detected by side assist. When the difference in speed is greater, the signal light will not come on. ■

Applies to vehicles: with Audi side assist

Informational and alert stage signals

Side assist has two signal stages:

- the informational stage signal, and
- the alert stage signal.

Side assist helps you by using the appropriate signal stage, depending on whether or not you have activated the turn signal, and thus have indicated that you are or are not changing lanes.

Informational stage signal

As long as you have not activated the turn signal, side assist informs you of detected vehicles that are registered as being in a notable location if you were to change lanes. Whenever the detected vehicle's difference in speed and distance is registered by side assist as notable, the signal light on the respective mirror produces muted illumination.

The brightness of the informational stage signal is designed not to be as intense, so that it does not interfere with your view of the road when you are driving and have no intention of changing lanes. ►

When you look in the outside mirror, you can clearly see the informational stage signal.

Alert stage signal

When you activate the turn signal, and side assist has detected a vehicle in a notable location on that particular side, the signal light on this side mirror flashes brightly. The repeated brief and bright flashing of the alert stage signal reminds you to carefully check traffic to the rear in the outside mirror and over your shoulder, so that you can safely complete the lane change ⇒ ⚠ in "Safety tips" on page 127.

Tips

The brightness of the signal light on the outside mirrors can be adjusted with the MMI ⇒ page 125. ■

Applies to vehicles: with Audi side assist

Driving situation: Fast approaching vehicles

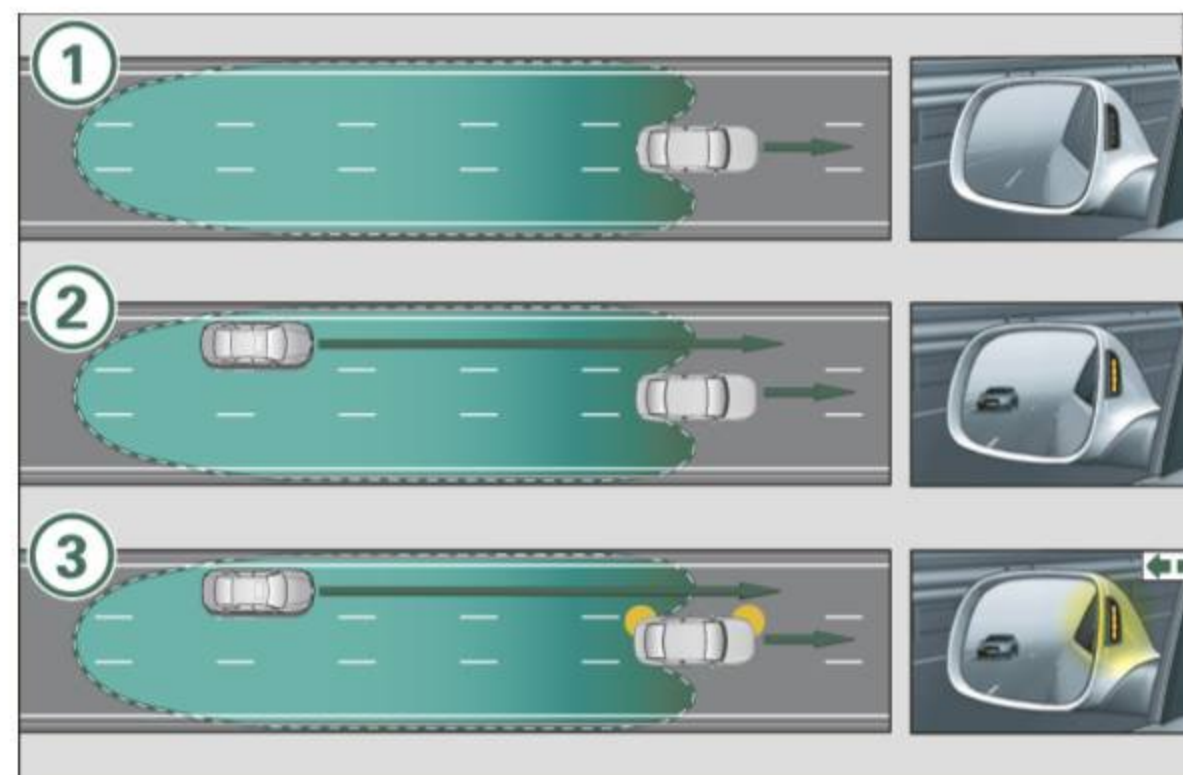


Fig. 127 Side assist: Fast approaching vehicles

① Signal on outside mirror does not light up

No vehicle was detected by the sensors. The signal on the outside mirror does not light up ⇒ ⚠ in "Safety tips" on page 127.

② Informational stage signal lights up

A fast approaching vehicle - in the left-hand lane for example - was detected by the sensors. Although this vehicle is still far away, it should be taken into account if you were to change lanes, due to the considerable difference in speed. The informational stage signal on the outside mirror lights up ⇒ page 121.

③ Alert stage signal flashes

If you activate your turn signal in driving situation ②, the signal briefly flashes repeatedly. Side assist is alerting you to a vehicle that you may not have noticed. ▶

i Tips

- The faster a vehicle approaches from the rear, the sooner the signal on the outside mirror lights up. Side assist will signal, at the latest, when a detected vehicle enters your “blind spot”.
- When vehicles approach very quickly, changing lanes can be dangerous even if the signal on the outside mirror does not light up. ■

Applies to vehicles: with Audi side assist

Driving situation: Slowly approaching vehicles

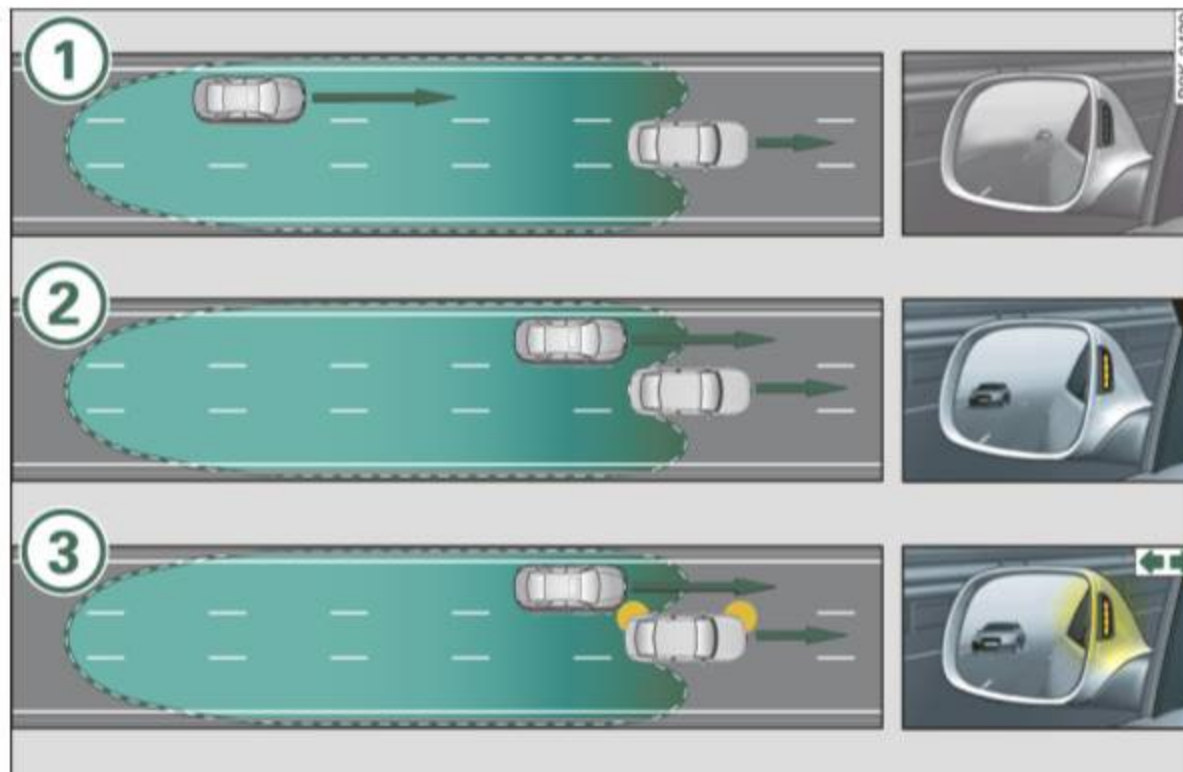


Fig. 128 Side assist: Slowly approaching vehicles and vehicles in your blind spot

① Signal on outside mirror does not light up

A vehicle approaching slowly - in the left-hand lane for example - was detected by the sensors. Because of the small difference in

speed and the considerable distance from your vehicle, the signal on the outside mirror will not light up ⇒ ⚠ in “Safety tips” on page 127.

② Informational stage signal lights up

The distance between your vehicle and that of the slowly approaching vehicle has narrowed. The informational stage signal on the outside mirror lights up.

As soon as the difference in speed and distance is registered as notable if you were to change lanes, a signal on the mirror lights up. Side assist will signal at the latest when a detected vehicle enters your “blind spot”.

③ Alert stage signal flashes

If you activate your turn signal in driving situation ②, the signal light briefly flashes repeatedly. Side assist is alerting you of a vehicle that you may not have noticed.

i Tips

- The faster a vehicle approaches from the rear, the sooner the signal on the outside mirror lights up. Side assist will signal, at the latest, when a detected vehicle enters your “blind spot”.
- When vehicles approach very quickly, changing lanes can be dangerous even if the signal on the outside mirror does not light up. ■

Applies to vehicles: with Audi side assist

Driving situation: Vehicles dropping back slowly

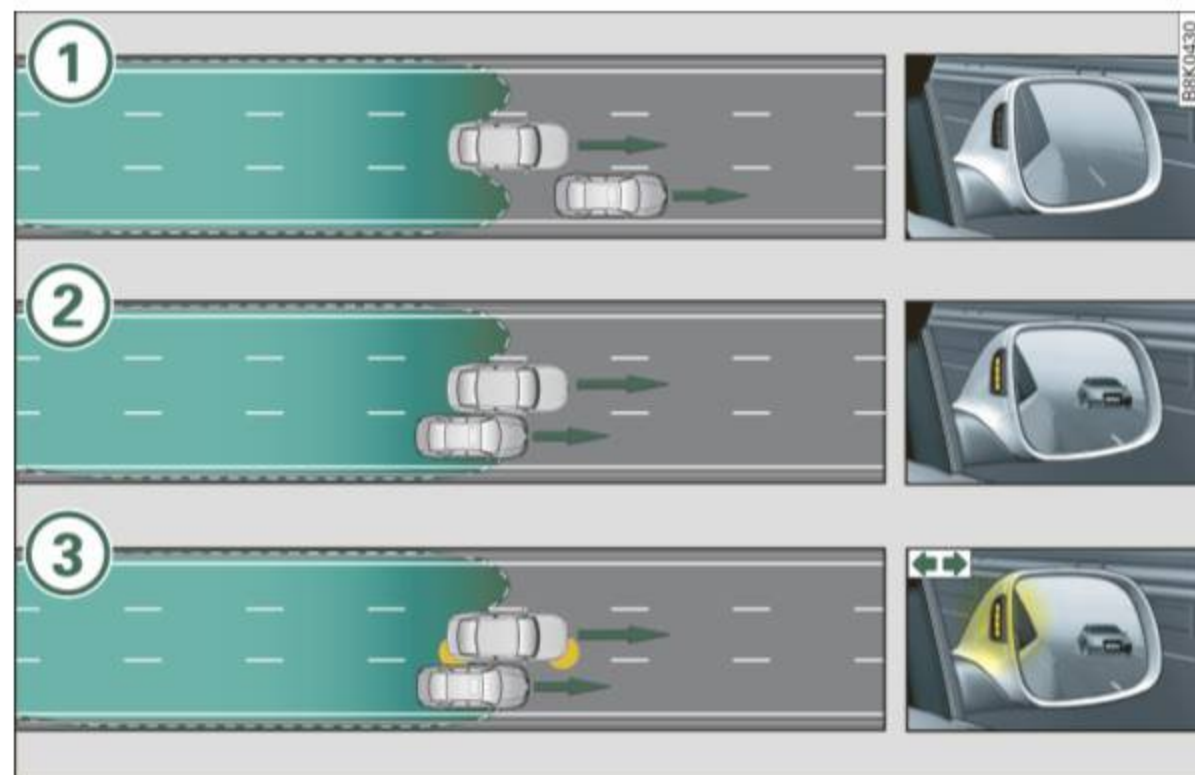


Fig. 129 Side assist: Vehicles dropping back slowly

① Signal on outside mirror does not light up

The vehicle that you passed has not yet been detected by side assist. The signal on the outside mirror does not light up ⇒ ⚠ in "Safety tips" on page 127.

② Informational stage signal lights up

A vehicle dropping back slowly on the right (difference in speed of less than 9 mph, or 15 km/h) has been detected by side assist. The informational stage signal on the outside mirror lights up.

③ Alert stage signal flashes

If you activate your turn signal in driving situation ②, the signal briefly flashes repeatedly. Side assist is alerting you of a vehicle that you may not have noticed. ■

Applies to vehicles: with Audi side assist

Driving situation: Vehicles dropping back quickly

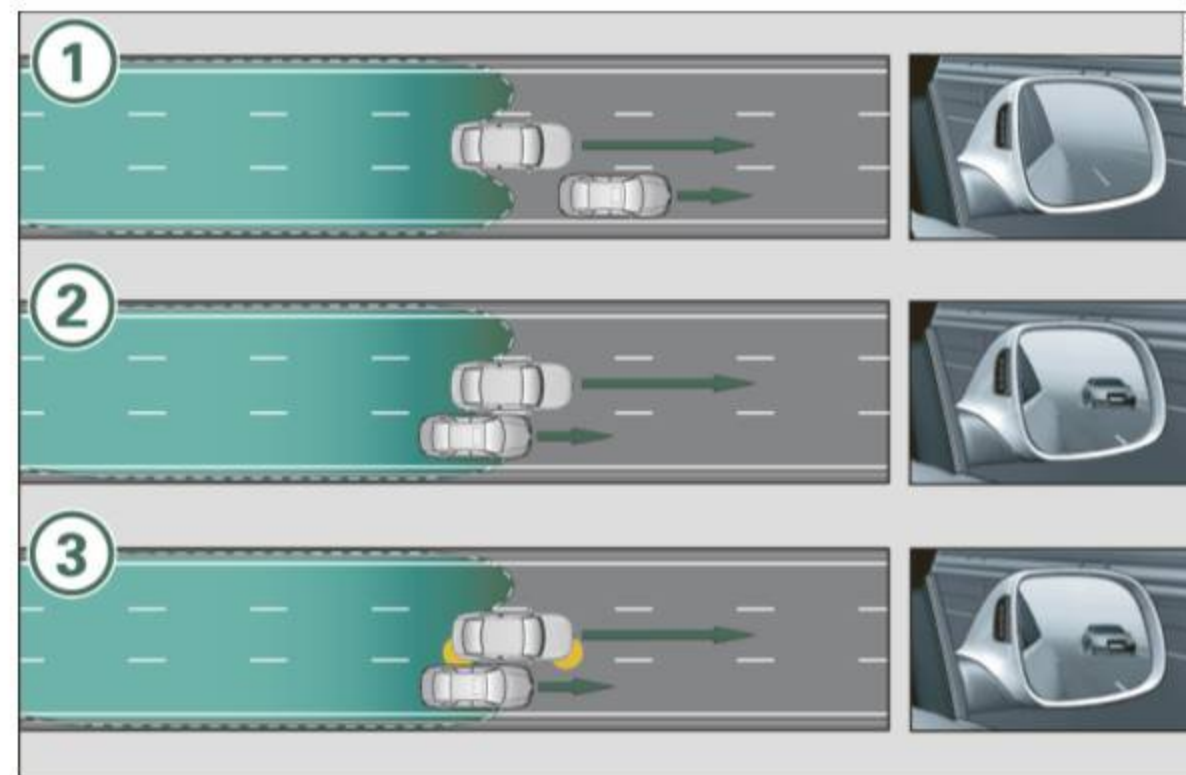


Fig. 130 Side assist: Vehicles dropping back quickly

① Signal on outside mirror does not light up

The vehicle just passed has not yet been detected by side assist. The signal on the outside mirror does not light up ⇒ ⚠ in "Safety tips" on page 127.

② Signal on outside mirror does not light up

The vehicle dropping back quickly on the right (difference in speed of more than 9 mph, or 15 km/h) has been detected by side assist, but is not considered notable in the event of a lane change, because it is dropping back so quickly. The signal on the outside mirror does not light up ⇒ ⚠ in "Safety tips" on page 127. ▶

③ Signal on outside mirror does not light up

If you activate your turn signal in driving situation ②, the signal still does not light up on the outside mirror ⇒ ⚠ in "Safety tips" on page 127. ■

Applies to vehicles: with Audi side assist

MMI settings

The basic brightness setting of the signal on the outside mirror can be adjusted via the MMI.

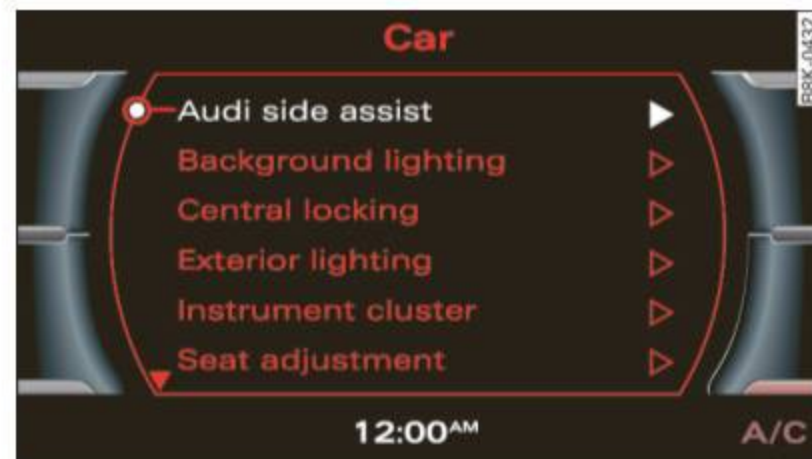


Fig. 131 MMI Display: Options menu



Fig. 132 MMI Display: Adjusting signal brightness

- Press the **CAR** function button.
- Select **Audi side assist** ⇒ fig. 131.

- Select **Warning lamp: brightness**.
- Rotate the control knob to adjust the displayed brightness of the signal light on the outside mirrors ⇒ fig. 132.

The brightness of the signal light for both the informational and alert stages is automatically adjusted to ambient light conditions. In addition, you can adjust the *basic brightness* separately, via the brightness function ⇒ fig. 132.

While making the adjustment, the new brightness setting is displayed briefly. The brightness displayed is that of the informational stage signal. The alert stage signal brightness is linked to the informational stage signal brightness.

The informational stage signal brightness should be adjusted so that you notice the signal illumination when you look in the outside mirror, but not when you look forward through the windshield.

In very dark or light surroundings, the automatic brightness setting adjusts signal light brightness to maximum or minimum intensity, as needed. In circumstances such as these, you may not notice any change in the brightness on the outside mirror when adjusting the *basic brightness*.

You may not notice the change until lighting conditions are normal again.

i Tips

- Side assist is not active when the basic brightness is adjusted. The signal light comes on briefly to help you make the adjustment.
- Your settings are automatically stored and assigned to the remote control key being used. ■

Applies to vehicles: with Audi side assist

General information

Side assist has limits and cannot detect vehicles under all road and weather conditions. Please remember system limitations and never rely on the system, especially when:

- driving through curves ⇒ *page 126*,
- lanes are of different widths ⇒ *page 126*. ■

Applies to vehicles: with Audi side assist

When driving through curves

Side assist cannot detect vehicles in curves with a turning radius of less than 218 yards (200 m).

When driving through a curve, it is possible that side assist may register a vehicle two lanes over, and the signal on the outside mirror will light up. ■

Applies to vehicles: with Audi side assist

Lane width

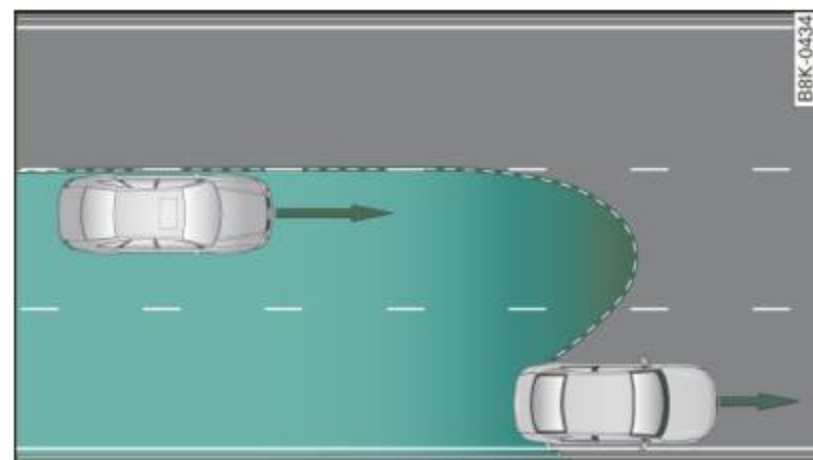


Fig. 133 Lanes of a normal width are in detection area

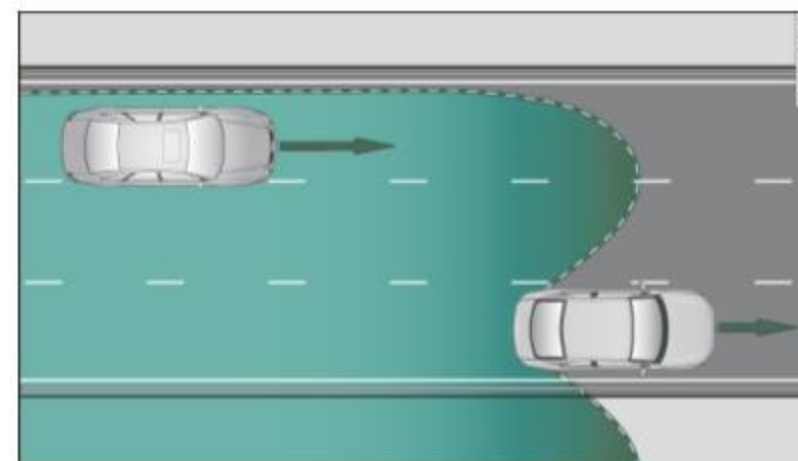


Fig. 134 Narrow lanes: Side assist may detect vehicles two lanes away

Side assist's detection area is designed to cover lanes of standard width to the left and right of your travel lane, depending on whether you drive in the center of your lane or closer to the edge.

If you drive in narrow lanes, side assist's detection area may also include other lanes - especially if you tend to drive on the edge of your lane ⇒ fig. 134. Under these conditions, vehicles can also be detected that are two lanes away, and side assist then could switch between the informational and warning stage signals.

When driving in very wide lanes, vehicles in the adjacent lane may not be detected because they are not inside the detection area. ■

Notes

Applies to vehicles: with Audi side assist

Messages in instrument cluster display

If side assist turns off automatically, the indicator light on the button will go out and you will see a message in the instrument cluster display:

Audi side assist not available: sensors possibly blocked

The side assist sensors are built into the rear bumper on the left and right (not visible on the outside) ⇒ *page 119*, fig. 123. To ensure that you do not adversely affect the way side assist functions, foreign ►

objects (such as stickers or bicycle racks) should not be attached to the area on the rear bumper where the sensors are located. If side assist functions are adversely affected, you will see this message in the instrument cluster display. Remove anything that may be blocking the sensors.

If no vehicle is detected for a longer period of time while driving, side assist will also switch off automatically.

Audi side assist currently not available

If there is a temporary problem (such as the vehicle's battery charge being low), side assist cannot be activated temporarily.

Audi side assist: system fault

Have the system checked by an authorized Audi dealer or qualified workshop.

Audi side assist not available when towing

The radar sensor's view is limited when towing a trailer. For vehicles with a trailer hitch that was installed later according to factory specifications, side assist is automatically deactivated as soon as the electrical connection to the trailer's electrical socket is made, and this status message appears in the instrument cluster display. Deactivation cannot be guaranteed when using a retrofitted towing hitch that was **not** installed according to factory specifications. ■

Applies to vehicles: with Audi side assist

Safety tips

The side assist detection may be limited when driving around narrow street corners, on hilly streets, and under poor weather conditions.

It is possible that the radar sensors may also detect other objects, such as high or staggered guardrails.

Side assist does not measure actual lane width. The system assumes a fixed lane width. Detection in the left and right lanes is

based on this assumed lane width. When driving on narrow roads or when driving to the left or right of the center of a travel lane, it is possible that vehicles will be detected that are *not* in the lane next to the lane you are using.

WARNING

- **Improper reliance on the side assist system can cause collisions and serious personal injury:**
 - **Never rely only on side assist when changing lanes.**
 - **Always check rear view mirrors to make sure that it is safe to change lanes.**
- **Side assist cannot detect all vehicles under all conditions—danger of accident!**
- **Side assist cannot detect vehicles in time to alert you when they approach from behind at very high speed, or fall drop back very quickly.**
- **The radar sensor's *vision* can be reduced or entirely blocked by rain, snow, and heavy spray. This can result in side assist not adequately detecting vehicles or, in some cases, not detecting them at all. Always keep an eye on the direction you are traveling and the relevant area around the vehicle.**
- **Please note that side assist indicates there are approaching vehicles, or vehicles in your blind spot, only after your vehicle has reached a driving speed of at least 37 mph (60 km/h).**
- **Side assist signal does not work around tight corners (turning radius less than 218 yards, or 200 m).**
- **Side assist is no replacement for the driver's full attention. The driver alone is responsible for lane changes and similar driving maneuvers. Always keep an eye on the direction you are traveling and the relevant area around the vehicle.**

 **Note**

To ensure that side assist is not adversely affected, you should not block the area on the rear bumper where the radar sensors are located with foreign objects (such as with stickers or bicycle racks).

 **Tips**

If the positions of the radar sensors have been changed as a result of a rear end-collision, for instance, have side assist checked by an authorized Audi dealer for safety reasons. ■

Applies to vehicles: with Audi side assist

Declaration of compliance

The Audi side assist system is based on radar sensors which operate in one of two frequency bands at 24 GHz. In some countries only one of both bands is allowed. Depending on the country in which you are driving, the Audi side assist system may not be legally activated unless the frequency band permitted has been set by an authorized Audi dealer. Operation in the US and Canada is only permitted on the 24075 MHz to 24175 MHz frequency band. The correct frequency band was set by Audi or an authorized Audi dealer in the country where your vehicle was originally purchased and may have been reset if the vehicle was operated outside the US or Canada. Changes or modifications not expressly approved by Audi can void the user's authority to operate the Audi side assist system.

This device complies with Part 15 of the FCC Rules. Operation is subject to the following two conditions:

- this device may not cause harmful interference, and
- this device must accept any interference received, including interference that may cause undesired operation. ■

Transmission

Manual transmission

Applies to vehicles: with manual transmission

Gearshift lever

The clutch pedal must be depressed all the way before you can start the engine.

The manual transmission in your Audi is equipped with an *interlock-feature*.

- Depress the clutch pedal all the way.
- Start the engine with the gearshift lever in Neutral and the clutch pedal depressed.

Note

Always depress the clutch pedal fully when changing gears. Do not hold the vehicle on a hill with the clutch pedal partially depressed. This may cause premature clutch wear or damage.

Tips

- Resting your hand on the gearshift lever knob while driving will cause premature wear in the transmission.
- The back-up lights go on when you shift into Reverse with the ignition on. ■

Applies to vehicles: with manual transmission

Gearshift pattern (6-speed manual transmission)

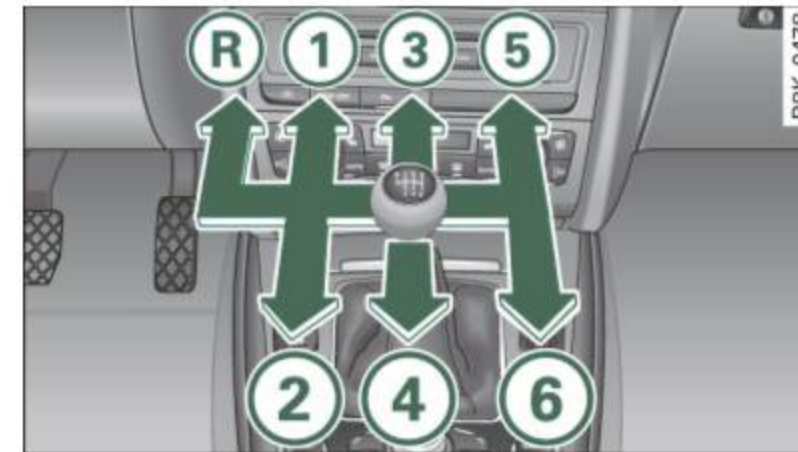


Fig. 135 Gearshift pattern: 6-speed manual transmission

Engaging reverse gear (R)

- Move the shift lever all the way to the left, press it down, then push it forward.

Especially after driving forward, stop the vehicle completely, shift into *Neutral* and rest the shift lever briefly in *Neutral* before shifting into *Reverse*. ■

tiptronic® (6-speed automatic transmission)

Applies to vehicles: with 6-speed automatic transmission

General information

Your vehicle is equipped with an electronically controlled 6-speed automatic transmission. Upshifting and downshifting takes place *automatically*. ►

The transmission is also equipped with tiptronic®. It allows the driver to shift gears *manually* if desired ⇒ *page 134*. ■

Applies to vehicles: with 6-speed automatic transmission

Driving the automatic transmission



Fig. 136 Shift gate on the center console: selector lever with release button

Starting the engine

- The selector lever must be in **N** or **P**.

Starting off

- Press and hold the brake pedal.
- Press and hold the release button in the selector lever handle and move the selector lever from **P** or **N** to **D** and release the button ⇒ ⚠.
- Wait briefly until the transmission has shifted (you will feel a slight movement).
- Remove your foot from the brake pedal and accelerate.

Rocking back and forth to become unstuck

- Shift only between **D** and **R** when the vehicle is at a full stop and the engine is running at idle speed.

Stopping

- Press and hold the brake pedal until the vehicle has come to a complete stop.
- Keep the brake pedal depressed so that the vehicle cannot roll forward or backward while it is idling ⇒ ⚠.
- Once stopped, *do not* depress the accelerator pedal to rev up the engine ⇒ ⚠.

Parking

- Press and hold the brake pedal until the vehicle has come to a complete stop.
- Set the parking brake firmly ⇒ *page 114*, “Parking”.
- Press and hold the release button in the selector lever handle, move the selector lever into **P** and then let go of the release button ⇒ ⚠.

The selector lever must be in **N** or **P**. If one of the driving positions is engaged a safety switch will prevent the engine from being started. See also ⇒ *page 109*.

Before you move the selector lever from the **P** position, you must always apply the brake pedal before and while depressing the button in the handle of the selector lever.

⚠ WARNING

- **Unintended vehicle movement can cause serious injury.**
 - **When the selector lever is in a driving position, the vehicle may creep, even at idle speed. Therefore do not release the parking brake or foot brake until you are ready to move, because power is transmitted to the wheels as soon as a driving position is engaged.**

⚠ WARNING (continued)

- Do not accelerate while selecting a driving position. At this time the engine must be at idle speed so that undue stress is not placed on the clutches in the transmission.
- Remember: - even when stopped briefly with the automatic transmission in "D", "S" or "R", engine power is being transmitted to the wheels. Your vehicle could "creep" forward or backward. When stopped, keep the brake pedal fully depressed and use the parking brake if necessary to keep the vehicle from rolling.
- If the selector lever is unintentionally moved into N while you are driving, take your foot off the accelerator pedal and wait for the engine to return to idle speed before selecting a driving position.
- Never shift into "R" or "P" when the vehicle is in motion.
- Never get out of the driver's seat when the engine is running.
- If you must get out of the vehicle, move the selector lever securely into the P position and apply the parking brake firmly.
- If the engine must remain running, never have any driving position engaged when checking under the hood. Make sure the selector lever has securely engaged and is locked in "P" with the parking brake firmly set ⇒ *page 251*, "Engine compartment". Otherwise, any increase in engine speed may set the vehicle in motion, even with the parking brake applied. ■

Applies to vehicles: with 6-speed automatic transmission

Selector lever positions

This section describes the selector lever positions and driving ranges.



Fig. 137 Display in the instrument cluster: selector lever in position P

The selector lever position engaged appears next to the selector lever as well as in the instrument cluster display.

P - Park

In this selector lever position the transmission is mechanically locked. Engage **P** only when the vehicle is *completely stopped* ⇒ ⚠ in "Driving the automatic transmission" on *page 130*.

To shift in or out of position **P**, you must *first* press and hold the brake pedal *and then* press the release button in the selector lever handle while moving the selector lever to or from **P**. You can shift out of this position only with the ignition on.

R - Reverse

The transmission will automatically select the **lowest gear ratio** when you shift into reverse.

Select **R** only when the vehicle is at a *full stop* and the engine is running at idle speed ⇒ ⚠ in "Driving the automatic transmission" on *page 130*. ▶

Before you move the selector lever to **R**, press *both* the button in the handle of the selector lever *and* the brake pedal at the same time.

When the ignition is on, the backup lights illuminate when the selector lever is moved into **R**.

N - Neutral

The transmission is in neutral in this position. Shift to this position for standing with the brakes applied ⇒ *page 132*.

When the vehicle is stationary or at speeds below 3 mph (5 km/h), you must always apply the footbrake before and while moving the lever out of **N**.

D - Normal position for driving forward

Position **D** is for normal city and highway driving. It ranges from zero to top speed and all six gears shift automatically, depending on engine load, driving speed and automatically selected shift programs. The gear engaged is shown in the right of the display ⇒ *page 131, fig. 137*.

When the vehicle is stationary or at speeds below 3 mph (5 km/h), you must always apply the foot brake before and while moving the lever to **D** out of **N**.

In certain circumstances it may be advantageous to temporarily switch to the manual shift program to manually select gear ratios to match specific driving conditions ⇒ *page 134*.

S – Sport position*

Select this position for sportier performance. In this position, the transmission will not upshift as soon, allowing the vehicle to use the increased power available at higher engine speeds to achieve livelier acceleration.

When the vehicle is stationary or at speeds below 3 mph (5 km/h), you must always apply the foot brake before and while moving the lever to **S** out of **N**.

! WARNING

Read and follow all WARNINGS ⇒ ! in “Driving the automatic transmission” on *page 130*.

! Note

Coasting downhill with the transmission in N and the engine not running will result in damage to the automatic transmission and possibly the catalytic converter. ■

Applies to vehicles: with 6-speed automatic transmission

Automatic Shift Lock (ASL)

The Automatic Shift Lock safeguards you against accidentally shifting into a forward or the reverse gear and causing the vehicle to move unintentionally.



Fig. 138 Shift gate: selector lever lock positions and interlock button highlighted

The selector lever lock is released as follows:

- Turn the ignition on.
- Step on the brake pedal. *At the same time* press and hold the interlock button on the side of the gear selector knob ⇒ *fig. 138* with your thumb until you have moved the selector lever to the desired position. ▶

Automatic selector lever lock

The selector lever is locked in the **P** and **N** positions when the ignition is turned on. To move the lever from these positions the driver must depress the brake pedal. As a reminder to the driver, the following warning appears in the instrument cluster display when the selector is in **P** and **N**:

When stationary apply footbrake while selecting gear

A time delay element prevents the selector lever from locking when it is moved through the **N** position (going from **R** to **D**). The locking element will lock the selector lever if the lever is left in **N** (Neutral) for more than approximately 1 second, without the brake pedal being pressed.

At speeds above about 3 mph (5 km/h) the Automatic Shift Lock is automatically deactivated in the **N** position.

Interlock button

The lock button on the selector lever prevents the lever from being accidentally shifted into certain positions. Pressing this button deactivates the selector lever lock. Depending on the direction of the shift, the selector lever locks at different positions. The positions are highlighted in the illustration ⇒ *page 132, fig. 138.*

Ignition key safety interlock

The key cannot be removed from the ignition unless the selector lever is in the **P** park position. When the ignition key is removed, the selector lever will be locked in the **P** position. ■

Applies to vehicles: with 6-speed automatic transmission

Kick-down

The kick-down feature allows the vehicle to generate maximum acceleration.

When you press the accelerator pedal beyond the resistance point that is reached at full throttle, the transmission will select a lower gear ratio based on vehicle speed and engine RPM. The engine RPM

will be controlled to produce maximum vehicle acceleration as long as you continue to press the accelerator pedal beyond this resistance point.



WARNING

Be careful when using the kick-down feature on slippery roads. Rapid acceleration may cause the vehicle to skid. ■

Applies to vehicles: with 6-speed automatic transmission

Dynamic shift program (DSP)

The automatic transmission is electronically controlled.

The transmission is self adapting and will **automatically** select the best shift program suited to the driving conditions and driving style.

The transmission will select one of the **economy** programs when you drive at a steady speed or a gradually changing speed without heavy acceleration. This achieves optimum fuel efficiency, with early upshifting and delayed downshifting.

The transmission will automatically select the **sporty** shift programs when you drive at higher speeds, or with heavy acceleration and frequently changing speeds. Upshifts are delayed to make full use of engine power. Downshifting takes place at higher engine speeds than in the economy programs.

The selection of the most suitable shift program is a continuous, automatic process. The driver can also make the transmission switch to a sporty program by **quickly** pressing down the gas pedal.

This causes the transmission to shift down to a lower gear to achieve rapid acceleration, e.g. for quickly passing another vehicle. You do not need to press the gas pedal into the kick-down range. After the transmission has upshifted, the original program is selected according to your driving style.

An additional shift program allows the automatic transmission to select the proper gear for uphill and downhill gradients. ▶

This keeps the transmission from shifting up and down unnecessarily on hills. The transmission will shift down to a lower gear when the driver presses the brake pedal on a downhill gradient. This makes use of the braking effect of the engine without the need to shift down manually. ■

Applies to vehicles: with 6-speed automatic transmission

Manual shift program

Using the manual shift program you can manually select gears.



Fig. 139 Center console: shifting the tiptronic® manually



Fig. 140 Display: manual shift program, selected gear highlighted

Switching to manual shift program

- Push the selector lever to the right from D. As soon as the transmission has switched over, the selected gear appears in the display.

To upshift

- Push the selector lever forward to the plus position (+) ⇒ fig. 139.

To downshift

- Push the lever to the minus position (-).

When accelerating, the transmission will automatically shift into gears 2, 3, 4, 5 or 6 before the engine reaches its maximum RPM.

If you apply a light throttle when accelerating, tiptronic® will automatically shift from 1st to 2nd gear to save fuel. If you apply a heavy throttle, the transmission will stay in 1st gear until near maximum RPM is reached, or until the driver shifts into 2nd gear.

If you take your foot off the accelerator pedal when driving down a steep incline, tiptronic® will downshift from the selected gear into the next lower gear until it reaches 1st gear, based on road speed and engine RPM. Automatic downshifting is interrupted as soon as you apply the throttle again.

Tips

- When you shift into the next lower gear, the transmission will downshift only when there is no possibility of over-revving the engine.
- When the kickdown comes on, the transmission will shift down to a lower gear, depending on vehicle and engine speeds.
- tiptronic® is inoperative when the transmission is in the fail-safe mode. ■

Applies to vehicles: with tiptronic-steering wheel

Steering wheel with tiptronic®

The shift buttons on the steering wheel allow the driver to shift gears manually.



Fig. 141 Steering wheel: Shift buttons

- To downshift, touch the button on the left (-).
- To upshift, touch the button on the right (+).

The shift buttons are activated when the selector lever is in D, S or in the manual shift program (tiptronic).

Of course, you can continue to use the manual shift program with the selector lever on the center console. ■

Applies to vehicles: with 6-speed automatic transmission

Fail-safe mode

If tiptronic® suffers a malfunction, the fail-safe mode maintains minimum driveability.

In the event of particular system malfunctions, the automatic transmission switches to the fail-safe mode. This is signalled by all the segments in the display illuminating or going out.

You can continue to move the selector lever to all positions. The manual shift program (tiptronic) is switched off in the fail-safe mode.

In selector lever positions D and S and in the manual shift program, the transmission remains in 3rd gear if 1st, 2nd or 3rd gear was engaged previously. The transmission remains in 5th gear, if 4th, 5th or 6th gear was engaged previously.

The next time you drive off or start the engine, 3rd gear is engaged.

You can continue to use reverse gear. But the electronic lockout for reverse gear is turned off.

! Note

If the transmission switches to fail-safe mode, you should take the vehicle to an authorized Audi dealership as soon as possible to have the condition corrected. ■

Applies to vehicles: with 6-speed automatic transmission

Emergency release of the selector lever

If the vehicle's power supply fails, the selector lever can be released in an emergency.

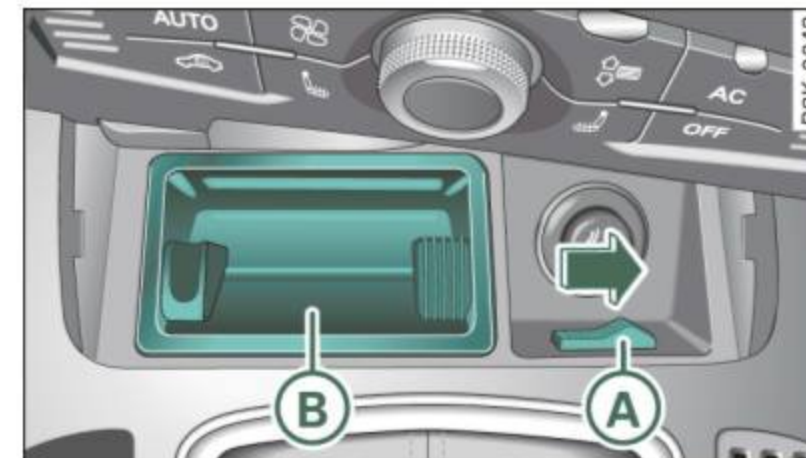


Fig. 142 Removing ashtray insert



Fig. 143 Emergency release for selector lever

The emergency release is located under the insert for the ashtray.

- Slide open the cover for the ashtray.
- Release the ashtray by pushing the switch **(A)**
⇒ *page 135, fig. 142 to the right.*
- Remove the ashtray insert **(B)**.
- Now you can see a small cover in the ashtray holder on the front of the ashtray recess.
- Release and remove this cover.
- You now have access to a bolt. Using a screwdriver or similar, press the bolt down and hold it down ⇒ *fig. 143.*
- Now press the interlock and move the selector lever to the N position.

The selector lever can only be moved from the P position if the ignition key is in the lock and the ignition is turned on. If the vehicle has to be pushed or towed if the power supply fails (e.g. battery is discharged), the selector lever must first be moved to the N position using the emergency locking device. ■

Audi Parking System

Audi Parking System

Applies to vehicles: with Audi Parking System (rear) and rear-view camera

General Information

Different park assist systems may be used for parking or maneuvering, depending on the vehicle's features.

For the *Audi Parking System (rear, with rear-view camera)*, the rear acoustic park assist system is integrated in the rear of the vehicle and the rear-view camera is integrated in the rear lid ⇒ *page 137*.

The *Audi Parking System (rear, with rear-view camera)* uses ultrasonic sensors to determine the distance of the vehicle from a detected obstacle. There are a total of four sensors located on the rear bumper (two in the middle and two on the sides). ■

Audi Parking System (rear, with rear-view camera)

Applies to vehicles: with Audi Parking System (rear) and rear-view camera

Acoustic parking system in the rear, with rear-view camera

The acoustic parking system gives an acoustic signal when detecting obstacles, and the rear-view camera offers further aid in the parking process.



Fig. 144 Rear lid: Location of the rear-view camera

Activation

- Put the vehicle in reverse gear, the acoustic parking system with rear-view camera is activated automatically. Activation of the acoustic parking system is confirmed by a brief acknowledgement sound. ▶

Deactivation

- Take the vehicle out of reverse gear. The acoustic parking system is immediately deactivated, and the rear-view camera picture is deactivated automatically after a period of about 15 seconds, or
- Switch the ignition off, the entire acoustic parking system is automatically deactivated.

The rear-view camera will deactivate automatically when you shift into a forward gear and drive faster than about 9 mph (15 km/h).

The delay in deactivating the camera provides an uninterrupted view behind the vehicle especially when maneuvering in tight parking spaces and prevents the picture from turning off the every time you shift out of reverse.

The vehicle-obstacle distance at which the sensors start to measure is **about**:

To the side	2 ft (0.60 m)
Center rear	5.2 ft (1.60 m)

Backing up

Distance notification when backing up starts when an obstacle is detected that is within range of the Audi Parking System. As the distance decreases, the time between the chimes gets shorter.

When the distance is less than 1 ft (0.30 m), the chime becomes a continuous tone. Here, at the latest, you should stop backing up.

Please note that low objects already signaled by Audi Parking System can become so close that they can no longer be detected and will not continue to be signaled.


If the distance to an obstacle stays the same, the volume of the distance signal chime is gradually reduced after about 4 seconds (does not affect the continuous signal tone). Approaching another

obstacle will cause the distance signal to sound again at the normal volume.

Distance signal tones

Distance is signaled by chimes from the rear signal generator. The volume and the pitch of the chimes can be adjusted in the MMI ⇒ *page 144*.

Rear-view camera (rear view)

The rear-view camera picture ⇒ *page 141*, fig. 150 appears in the MMI Display as a mirror image. The rear-view camera picture has orientation lines and marked surfaces projected into it, as an aid to the parking process ⇒ *page 139*. The red line in the picture ⇒ *page 139*, fig. 145 or ⇒ *page 139*, fig. 146 indicates the collision area. Here, at the latest, you should stop backing up ⇒ .

If the warning message appears in the display but not the rear-view camera picture, read and confirm the warning message. The acoustic distance signal is always active.

If you press a function button on the MMI terminal, the rear-view camera picture disappears. The rear-view camera picture reappears the next time you park.

Further information on the warning message and the MMI terminal can be found in the MMI instruction booklet.

WARNING

- **Sensors have blind spots in which objects cannot be detected. Be especially careful to check for small children and animals before backing up. Small children and animals will not always be detected by the sensors.**
- **The Audi Parking System is not a substitute for being careful and alert when backing up. Be especially careful during parking and similar maneuvers. Always watch where you are driving and make sure that nothing is in the way.**
- **Remember that low obstacles which have already been signaled may pass below the system's sensing zone when the**

⚠ WARNING (continued)

vehicle is backing up. The fact that the signal stops does not mean that you have cleared the obstacle. When the signal stops, impact is imminent. Objects such as trailer hitches, chains, narrow posts or fences covered by a thin layer of paint may not always be detected by the system. They can still damage your vehicle without warning.

- Always make sure that the volume and frequency of the chimes is adjusted so that you can easily hear the acoustic distance signal even if the radio is playing, the air-conditioner blower is on High or there is a high level of outside noise.
 - Check the settings whenever someone else has driven the vehicle before you.
- Improper reliance on the Audi Parking System can cause collisions and serious personal injury.
 - Never rely only on parking assist when backing up.
 - Always check rear view mirrors to make sure it is safe to back up.

i Tips

- The rear-view camera picture is available as soon as the MMI Display or the MMI is switched on, or the start-up phase is completed.
- Keep the sensors in the rear bumper and the rear-view camera lens clean and free of snow and ice, so that the Audi Parking System can work properly. Please follow the additional notes on ⇒ *page 144*. ■

Applies to vehicles: with Audi Parking System (rear) and rear-view camera

Rear-view camera

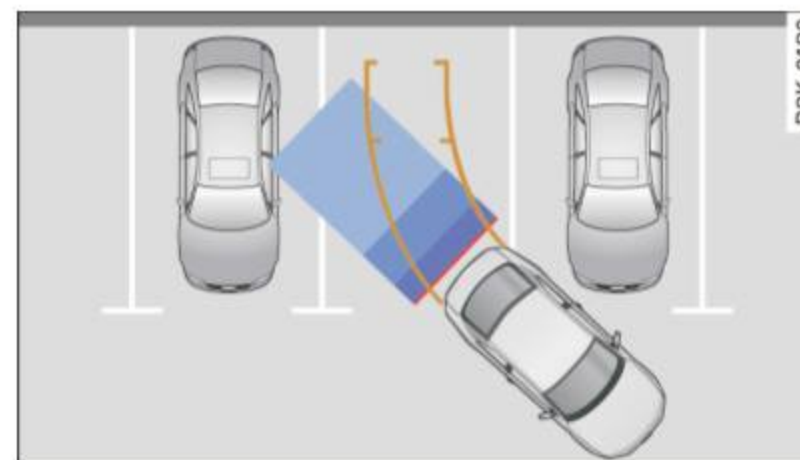


Fig. 145 View from top: Parking mode 1

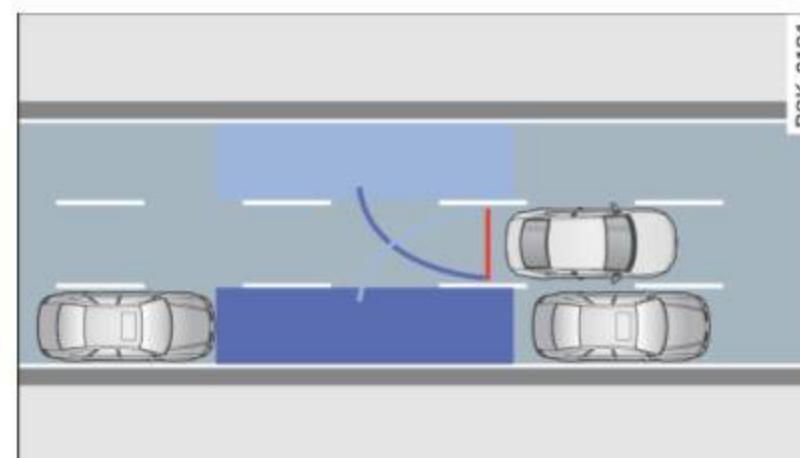


Fig. 146 View from top: Parking mode 2

Vehicles with the Audi parking system are equipped with a **rear-view camera** in addition to the acoustic and visual parking system.

You can choose between two modes to assist you with parking. For example, you can use "parking mode 1" when parking in a parking space or garage ⇒ fig. 145. When you want to park parallel to the edge of the street, select "parking mode 2" ⇒ fig. 146.

⚠ WARNING

- The rear-view camera has blind spots, in which objects cannot be detected. Be especially careful to check for small children and

! WARNING (continued)

animals before backing up. Small children and animals will not always be detected by the sensors. ■

Applies to vehicles: with Audi Parking System (rear) and rear-view camera

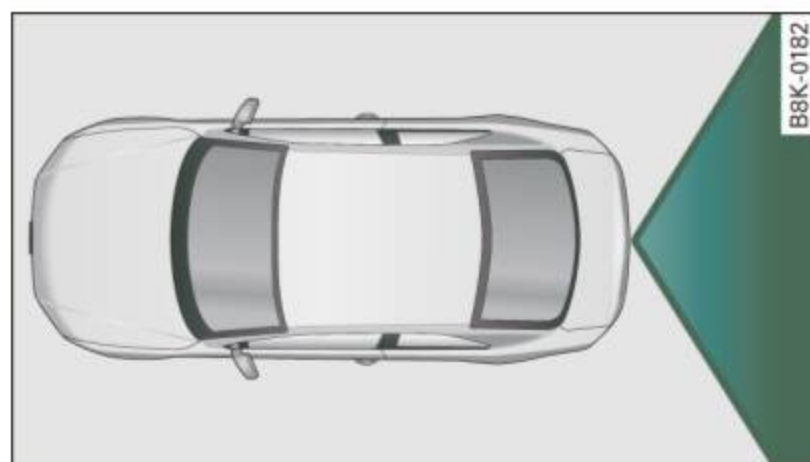
Rear-view camera coverage area

Fig. 147 Top view:
Rear-view camera
coverage area

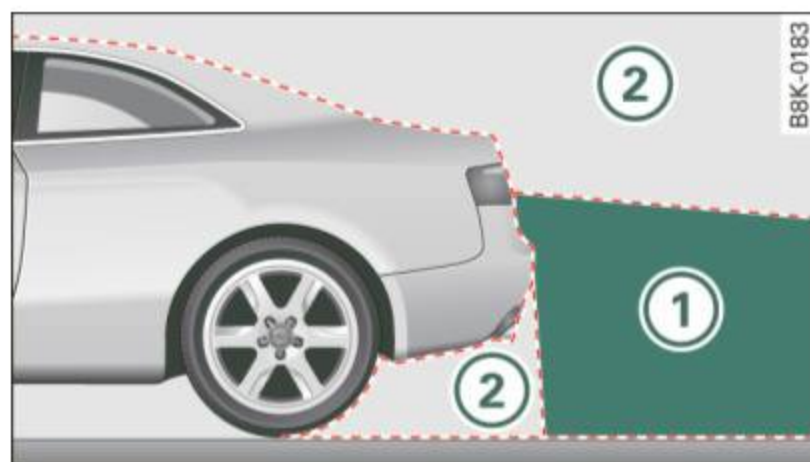


Fig. 148 Side view:
Uncovered area ① and
covered area ② of the
rear-view camera

The rear-view camera section appearing in the MMI Display is approximately the same as the coverage area represented in ⇒ fig. 147 or ② in ⇒ fig. 148. Objects located in the rear-view camera's uncovered area ① ⇒ fig. 148 or in the close vicinity of the bumper are not recognized.

! WARNING

Please note that objects not touching the ground can appear to be further away than they really are (for example, the bumper of a parked vehicle, a trailer hitch, or the rear of a truck). In this case, you should not use the guide help lines to measure distance - danger of accident! ■

Applies to vehicles: with Audi Parking System (rear) and rear-view camera

General instructions

Fig. 149 Trunk lid:
Location of the rear-
view camera

We recommend that you practice parking with the rear-view camera in a traffic-free location or parking lot to become familiar with the system, the orientation lines, and their function. When doing this, there should be good light and weather conditions.

In the MMI display, objects or vehicles appear closer or further away if:



- you are driving in reverse gear from a level surface onto an incline, or a downward slope,
- you are driving in reverse gear toward protruding objects,
- the vehicle is carrying too much load in the rear.

The accuracy of the orientation lines and blue surfaces diminishes if:

- the rear-view camera does not provide a reliable image, for example, in poor visibility conditions or if the lens is dirty,
- the image on the screen is not visible due to sun glare and reflection.

Caring for the rear-view camera lens

The rear-view camera is located above the rear license plate bracket. For the parking assist to operate, the lens ⇒ *page 140, fig. 149* must be kept clean:

- Dampen the lens with a household alcohol-based glass cleaner, and clean the lens with a dry cloth ⇒ .
- Remove snow with a hand brush and ice preferably with a de-icing spray ⇒ .

WARNING

- The parking aid cannot replace the driver's attention. The driver alone is responsible for parking and similar driving maneuvers.
- Always keep your eyes on the vehicle's surroundings, using the rear-view mirror as well.
- Do not allow yourself to be distracted from traffic by the rear-view camera pictures.
- If the position and the installation angle of the camera has changed, for example, after a rear end collision, do not continue to use the system for safety reasons. Have it checked by a qualified dealership.

Note

- Low obstacles already signaled by a warning can disappear from the system's detection range as they are approached and will not continue to be signaled. Objects such as barrier chains, trailer draw bars, thin painted vertical poles or fences may not be detected by the system, posing risk of damage.

- Never use warm or hot water to remove snow or ice from the rear-view camera lens - danger of crack formation on the lens!
- When cleaning the lens, never use products that are abrasive. ■

Applies to vehicles: with Audi Parking System (rear) and rear-view camera

Reverse Parking

Parking mode 1 can be used when parking in a garage or parking space.

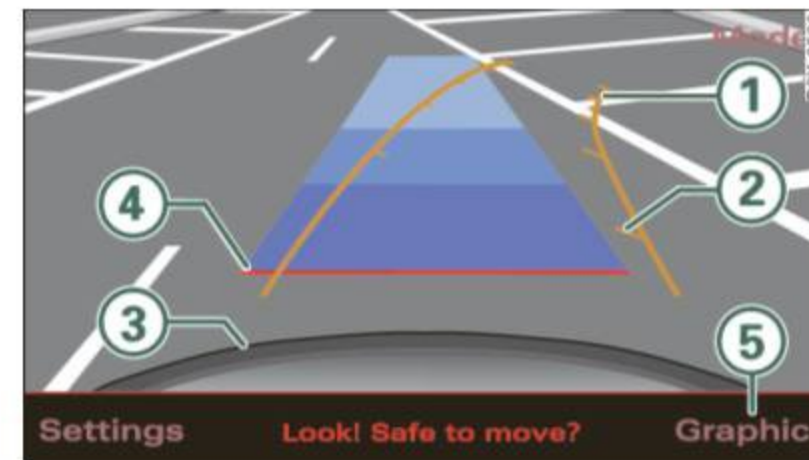


Fig. 150 MMI Display: Aiming at a parking spot

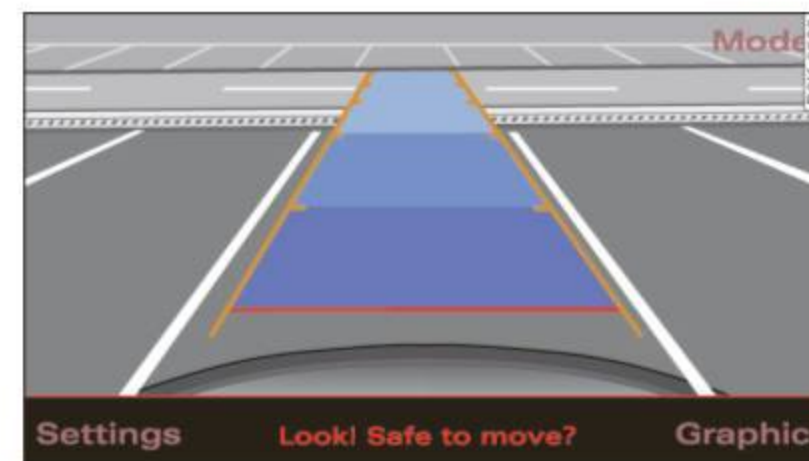








Fig. 151 MMI Display: Aligning the vehicle

- Turn the steering wheel until the orange orientation lines  appear in the parking spot ⇒ fig. 150. Use the markings  to help you estimate the distance from an obstacle. Each marking corresponds to 1 meter. ►

- While driving in reverse gear, adjust the steering wheel angle to fit the parking space with the aid of the orange orientation lines ⇒ .  marks the rear bumper. You should stop driving in reverse as soon as and no later than when the red orientation line  abuts an object ⇒ !
- Align your vehicle to correspond with the blue area ⇒ *page 141, fig. 151*. The blue area represents an extension of the vehicle's outline by approximately 5 m to the rear. The transitions of the blue surfaces are distanced approximately 1 m, 2 m, and 5 m away from the vehicle.

WARNING

- The rear-view camera does not show the entire area behind the vehicle ⇒ *page 140, fig. 148*. Watch out especially for small children and animals. The rear-view camera cannot always detect them, posing risk of an accident!
- Please note that objects not touching the ground can appear to be further away than they really are (for example, the bumper of a parked vehicle, a trailer hitch, or the rear of a truck). In this case, you should not use the help lines to help with parking, which poses danger of an accident!

Note

In the MMI display, the direction of travel of the vehicle rear is represented depending on the steering wheel angle. The vehicle front swings out more than the vehicle rear. Maintain plenty of distance from an obstacle so that your outside mirror or a corner of your vehicle does not collide with any obstacles - danger of accident! ■

Applies to vehicles: with Audi Parking System (rear) and rear-view camera

Parallel Parking

Use parking mode 2 to help you park on the edge of a street.

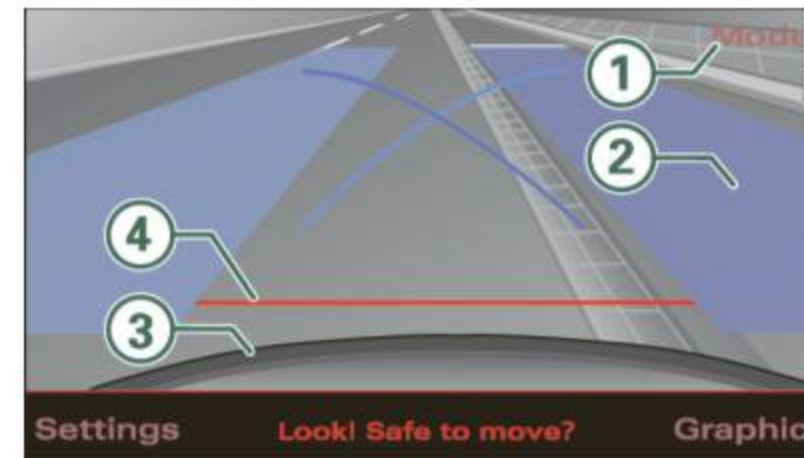


Fig. 152 MMI Display: Blue surface aligned with parking spot

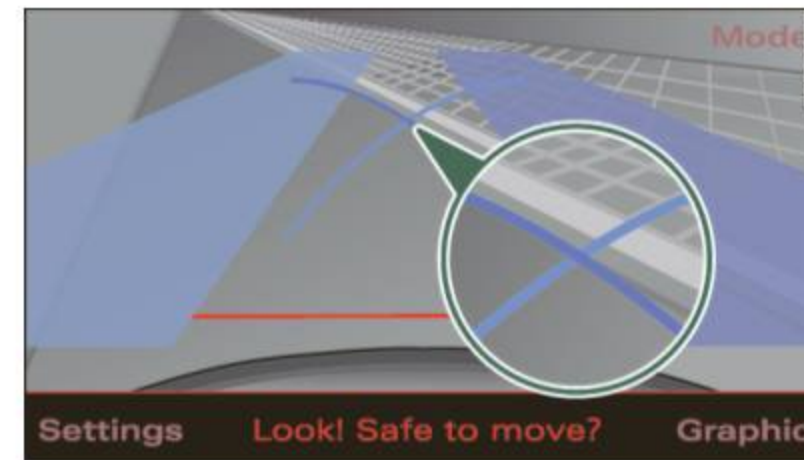








Fig. 153 MMI Display: Contact of the blue curved line with the curb

The following steps apply only when there is no obstacle (such as a wall) near the parking spot. Otherwise, please read the "Tips on Parking Next to Obstacles".

- Position your vehicle parallel to the edge of the street, approximately 1 meter from a parked vehicle.
- Select reverse gear. The parking aid turns on and parking mode 1 appears on the display. ▶

- Press the **Mode** ⇒ *page 142*, fig. 152  control button on the MMI terminal. Parking mode 2 appears.
- Back up in reverse gear and align your vehicle so that the blue area  borders on the rear end of the vehicle or on the parking spot line. The blue area represents an extension of the vehicle's outline by approximately 5 m to the rear. The long side of the blue area should be on the curb. The entire blue area must fit into the parking spot.
- While the vehicle is stationary, turn the steering wheel to the left as far as it will go.
- Back up into the parking spot.
- Stop the vehicle as soon as the blue curve ⇒ *page 142*, fig. 153 touches the curb.
- While the vehicle is stationary, turn the steering wheel to the right as far as it will go.
- Continue to back up into the parking spot until the vehicle is parked parallel to the curb.  marks the rear bumper. You should stop driving in reverse as soon as and no later than when the red orientation line  abuts an object ⇒ ! Keep an eye on the front of your vehicle while doing this ⇒ .

Parking Next to Obstacles

When there is an obstacle (such as a wall) next to the parking spot, choose a spot with more space on the sides. Position the long side of the blue area so that there is sufficient space from the curb. The area must not be on the curb. You will also need to start turning the steering wheel much earlier. There should be a sufficient amount of space between the curb and the blue curve, and the blue curve ⇒ *page 142*, fig. 153 must **not** touch the curb.

WARNING

- The rear-view camera does not show the entire area behind the vehicle ⇒ *page 140*, fig. 148. Watch out especially for small children and animals. The rear-view camera cannot always detect them, posing risk of an accident!
- Please note that objects not touching the ground can appear to be further away than they really are (for example, the bumper of a parked vehicle, a trailer hitch, or the rear of a truck). In this case, you should not use the help lines to help with parking, which poses danger of an accident!

Note

In the MMI display, the direction of travel of the vehicle rear is represented depending on the steering wheel angle. The vehicle front swings out more than the vehicle rear. Maintain plenty of distance from an obstacle so that your outside mirror or a corner of your vehicle does not collide with any obstacles - danger of accident!

Tips

The left or right orientation lines and surfaces will be displayed, depending on the turn signal being used. ■

Applies to vehicles: with Audi Parking System (rear) and rear-view camera

Adjusting the display and warning tones

The display and warning tones are adjusted in the radio or in the MMI*.*



Fig. 154 MMI Display: Adjusting parking assist

- Select: Function button **CAR** > **Audi parking system**.

Warning tones

- **Rear volume** - Volume of the rear sensors
- **Rear frequency** - Pitch of the rear sensors

The newly adjusted value is briefly heard from the signal generator.



Tips

- The warning tones can also be adjusted directly from the rear-view camera image*. Simply press the **Setting*** control button.
- Changed settings are activated when parking assist is switched on again.
- The settings are automatically stored and assigned to the remote control key. ■

Applies to vehicles: with Audi Parking System (rear) and rear-view camera

Acoustic parking system error message

If a warning tone is audible for about five seconds when you turn on the ignition, there is a malfunction in the system. Have the problem corrected by your authorized Audi dealer.

Keep the sensors in the rear bumper clean and free from ice so that the acoustic park assist system can function properly. ■

HomeLink®

Universal remote control

Applies to vehicles: with HomeLink® universal remote control

General information

The HomeLink® feature can learn up to three radio frequency codes for most current transmitters used for operating garage doors, estate gates, home or outdoor lighting systems, and other devices.

You must first program the HomeLink® transmitter before you can use the system ⇒ page 145, "Programming the HomeLink® transmitter".

In order to program the HomeLink® transmitter for devices utilizing rolling code, a second person on a ladder who can safely reach the garage door opener motor is recommended. It is also necessary to locate the "learn" button on your garage door opener motor. Refer to the operating instructions for the opener, as the location and color of this button may vary by manufacturer.

You can still use the original remote control for the device at any time.

WARNING

- **Never use the HomeLink® transmitter with any garage door opener that does not have the safety stop and reverse feature as required by federal safety standards. This includes any garage door opener model manufactured before April 1, 1982.**
- **A garage door opener which cannot detect an object, signaling the door to stop and reverse does not meet current federal safety standards. Using a garage door opener without these features increases risk of serious injury or death.**

WARNING (continued)

- **For safety reasons never release the parking brake or start the engine while anyone is standing in front of the vehicle.**
- **A garage door or an estate gate may sometimes be set in motion when the HomeLink® remote control is being programmed. If the device is repeatedly activated, this can overstrain motor and damage its electrical components - an overheated motor is a fire hazard!**
- **To avoid possible injuries or property damage, please always make absolutely certain that no persons or objects are located in the range of motion of any equipment being operated. ■**

Applies to vehicles: with HomeLink® universal remote control

Programming the HomeLink® transmitter

The transmitter is programmed in two phases. For rolling code transmitters, a third phase is also necessary.



Fig. 155 Overhead console: HomeLink® keypad

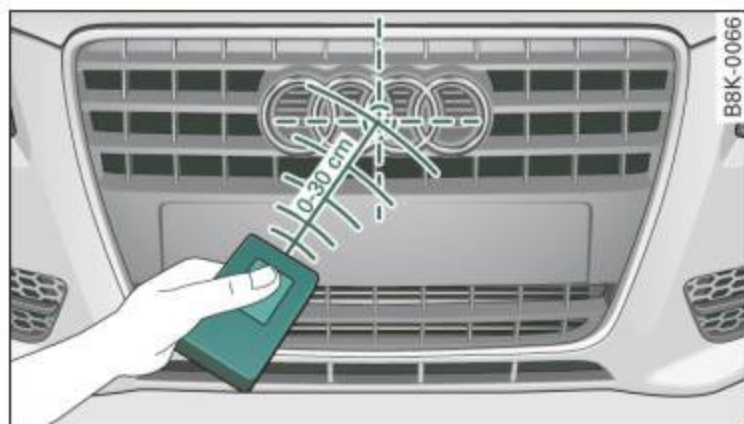











Fig. 156 Radiator grille

Phase 1: programming the overhead keypad

1. Make sure your vehicle is within operating range of the remote controlled garage door opener.
2. Set the parking brake ⇒  in "General information".
3. Turn the ignition on. Do not start the engine!
4. Press and hold the two outside HomeLink® buttons  and  for approximately 20 seconds until indicator light  ⇒ page 145, fig. 155 begins to flash. Then release both buttons. Do not hold the buttons for longer than 30 seconds.
 - This procedure only needs to be performed **once**. It erases the factory-set default codes and does not have to be repeated to program additional remote controls.
5. Press and hold the HomeLink® button ,  or  until the indicator light  starts flashing *slowly*. Release the button.
 - *The system will remain in programming mode for 5 minutes. Go to the front of the vehicle and proceed with phase 2.*

Phase 2: at the radiator grille

6. Point the **original remote control** to the middle of the radiator grille of your vehicle ⇒ fig. 156.
7. Hold the *original remote control* at a distance between 0–5 in. (0–13 cm) (use the shortest distance possible).
8. Press and hold the activation button on the remote control.
 - May be different in Canada. If so, press and re-press (cycle) the activation button on your remote control every two seconds.
9. The emergency flashers will flash **three times** (after about 15–60 seconds) when the programming is successful. Release the button on the remote control.
 - *To program more devices, repeat steps 4 to 9.*
10. Press and hold the trained HomeLink® button and observe the indicator light  ⇒ page 145, fig. 155.
 - If the indicator light is solid/continuous, programming is complete and your device should activate when you press and release the trained HomeLink® button.
 - If the indicator light blinks rapidly for 2 seconds and is then a solid/continuous light, proceed with phase 3 to program a rolling code device.

Phase 3: rolling code programming

- A second person on a ladder who can safely reach the garage door opener motor is recommended.
11. Locate the "learn" button on the garage door opener motor (refer to the operating instructions for the opener, as the location of this button may vary by manufacturer). ►

12. Press and release the learn button on the garage door opener motor.
 - **Note:** once the button is pressed, there are **30 seconds** in which to initiate the next step.
13. On the HomeLink® keypad inside the vehicle, firmly press and hold the HomeLink® button previously programmed in phases 1 and 2 for two seconds and release. Repeat this sequence **twice**.
 - Some vehicles may require the press/hold/release sequence up to three times to complete the training process.
 - *HomeLink® should now activate your rolling code equipped device.*

If the 5 minute time limit is exceeded, the **emergency flashers will flash one time** to indicate that the process has been terminated. In this case, repeat steps 4 through 9.

If the emergency flashers do not flash *three* times (after about 15–60 seconds), programming was not successful. In this case, repeat steps 4 through 9.

Remote control units for garage door openers in Canada are set to stop transmitting radio frequency signals after two seconds. This time may not be sufficient for the HomeLink® system to learn the radio frequency signal. Perform all other steps as described above. ■

Applies to vehicles: with HomeLink® universal remote control

Operating the HomeLink® transmitter

The HomeLink® transmitter works in the same manner as the original handheld remote control that came with the system.



Fig. 157 HomeLink® keypad

- Press the appropriate programmed button (I), (II) or (III) to activate the desired remote control function ⇒ ⚠ in “General information” on page 145. ■

Applies to vehicles: with HomeLink® universal remote control

Reprogramming a single button

A HomeLink® button can be reprogrammed individually without affecting the other button allocations.

Programming the overhead keypad

- Press the appropriate HomeLink® button until the indicator light begins flashing slowly.

At the radiator grille

1. Point the **original remote control** to the middle of the radiator grille of your vehicle ⇒ page 146, fig. 156. ►

2. Hold the *original remote control* at a distance between 0–5 in. (0–13 cm) (use the shortest distance possible).
 3. Press and hold the activation button on the remote control.
 4. The emergency flashers will flash **three times** (after about 15–60 seconds) when the programming is successful. Now release the button on the remote control.
- If the device utilizes a rolling code, please follow phase 3 of ⇒ *page 145*, “Programming the HomeLink® transmitter” for rolling code programming.

This procedure will cause the existing programming on the HomeLink® button to be erased! ■

Applies to vehicles: with HomeLink® universal remote control

Erasing the programming of the HomeLink® transmitter

When you erase the programming, the programming on all three of the transmitter channels will be lost!

- Perform steps 1 to 4 as described on ⇒ *page 146*, “Phase 1: programming the overhead keypad”.

When completed, the HomeLink® system will be in the programming mode and is then ready to learn the codes for remote controlled devices.

Tips

- Programmed buttons cannot be erased individually.
- For security reasons you are advised to erase the programming of the HomeLink® system before you sell your vehicle. ■

Applies to vehicles: with HomeLink® universal remote control

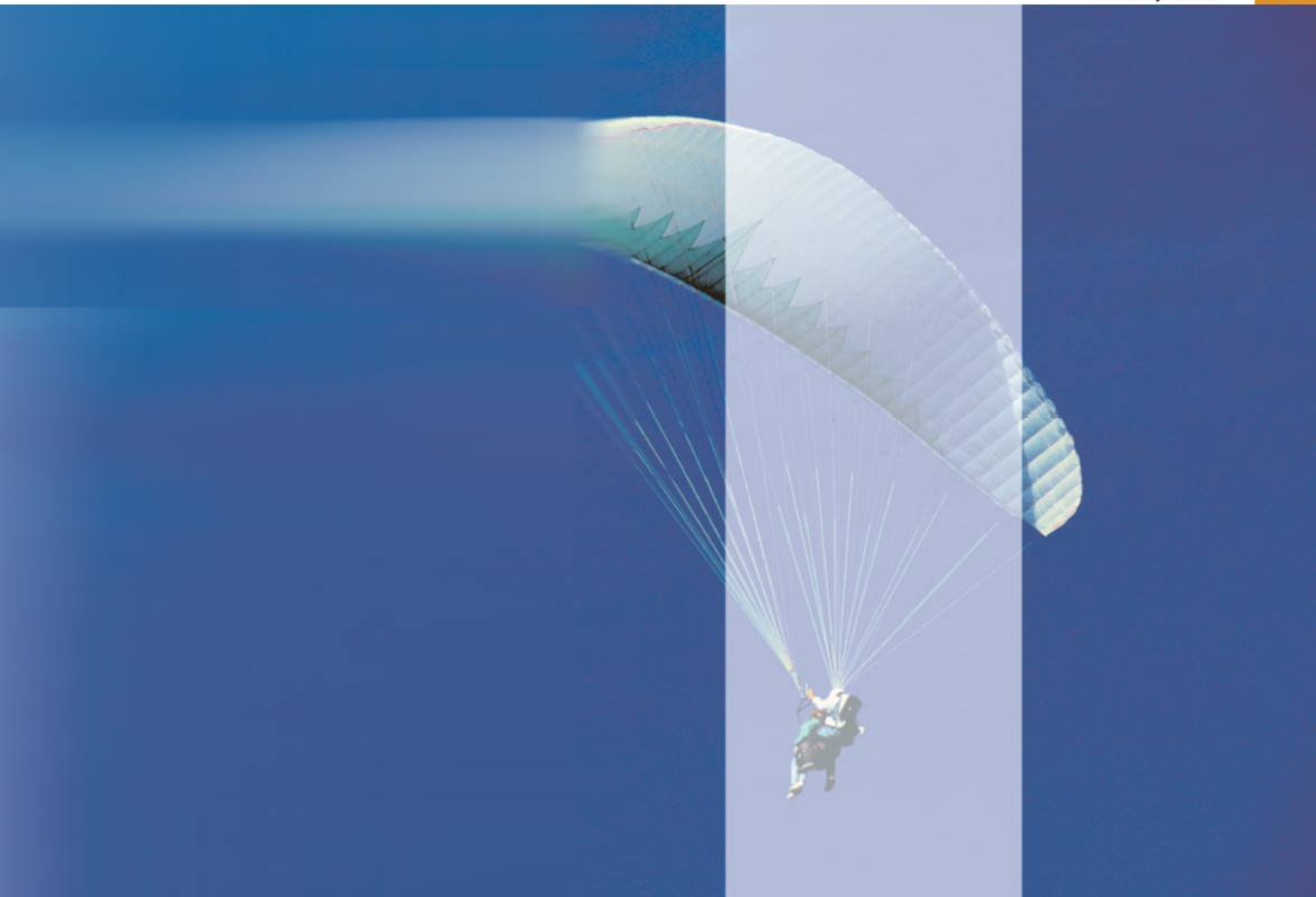
Information and accessories

If you would like more information on HomeLink®, where to purchase the HomeLink® compatible products, or would like to purchase the HomeLink® Home Lighting Package, please call toll-free: 1-800-355-3515.

Tips

- The HomeLink® universal transmitter complies with part 15 of the FCC rules and RSS-210 of IC part 15. Operation is subject to the following conditions:
 - this device may not cause harmful interference, and
 - this device must accept any interference that may be received including interference that may cause undesired operation.
- Changes or modifications not expressly approved by the party responsible for compliance could void the user’s authority to operate the device (DOC: ISTC 1763 102 264 Prince MODEL/FCC ID: CB2 V94800). ■





Driving Safely

General notes

Safe driving habits

Please remember - safety first!

This chapter contains important information, tips, instructions and warnings that you need to read and observe for your own safety, the safety of your passengers and others. We have summarized here what you need to know about safety belts, airbags, child restraints as well as child safety. Your safety is for us *priority number 1*. Always observe the information and warnings in this section - for your own safety as well as that of your passengers.

The information in this section applies to all model versions of your vehicle. Some of the features described in this sections may be standard equipment on some models, or may be optional equipment on others. If you are not sure, ask your authorized Audi dealer.

WARNING

- **Always make sure that you follow the instructions and heed the WARNINGS in this Manual. It is in your interest and in the interest of your passengers.**
- **Always keep the complete Owner's Literature in your Audi when you lend or sell your vehicle so that this important information will always be available to the driver and passengers.**
- **Always keep the Owner's literature handy so that you can find it easily if you have questions. ■**

Safety equipment

The safety features are part of the occupant restraint system and work together to help reduce the risk of injury in a wide variety of accident situations.

Your safety and the safety of your passengers should not be left to chance. Advances in technology have made a variety of features available to help reduce the risk of injury in an accident. The following is a list of just a few of the safety features in your Audi:

- sophisticated safety belts for driver and all passenger seating positions,
- belt force limiters for the seats,
- belt pretensioners for the seats,
- head restraints for each seating position,
- front airbags,
- side airbags in the front seats,
- side curtain airbags (SIDE GUARD),
- special LATCH anchorages for child restraints,
- adjustable steering column.

These individual safety features, can work together as a system to help protect you and your passengers in a wide range of accidents. These features cannot work as a system if they are not always correctly adjusted and correctly used.

Safety is everybody's responsibility! ■

Important things to do before driving


Safety is everybody's job! Vehicle and occupant safety always depends on the informed and careful driver.

For your safety and the safety of your passengers, **before driving always:**

- Make sure that all lights and signals are operating correctly.
- Make sure that the tire pressure is correct.
- Make sure that all windows are clean and afford good visibility to the outside.
- Secure all luggage and other items carefully ⇒ *page 97*.
- Make sure that nothing can interfere with the pedals.
- Adjust front seat, head restraint and mirrors correctly for your height.
- Instruct passengers to adjust the head restraints according to their height.
- Make sure to use the right child restraint correctly to protect children ⇒ *page 197, "Child Safety"*.
- Sit properly in your seat and make sure that your passengers do the same ⇒ *page 78, "General recommendations"*.
- Fasten your safety belt and wear it properly. Also instruct your passengers to fasten their safety belts properly ⇒ *page 163*. ■

What impairs driving safety?

Safe driving is directly related to the condition of the vehicle, the driver as well as the driver's ability to concentrate on the road without being distracted.

The driver is responsible for the safety of the vehicle and all of its occupants. If your ability to drive is impaired, safety risks for everybody in the vehicle increase and you also become a hazard to everyone else on the road ⇒ . Therefore:

- Do not let yourself be distracted by passengers or by using a cellular telephone.
- NEVER drive when your driving ability is impaired (by medications, alcohol, drugs, etc.).
- Observe all traffic laws, rules of the road and speed limits and plain common sense.
- ALWAYS adjust your speed to road, traffic and weather conditions.
- Take frequent breaks on long trips. Do not drive for more than two hours at a stretch.
- Do NOT drive when you are tired, under pressure or when you are stressed.

WARNING

Impaired driving safety increases the risk of serious personal injury and death whenever a vehicle is being used. ■

Proper occupant seating positions

Proper seating position for the driver

The proper driver seating position is important for safe, relaxed driving.

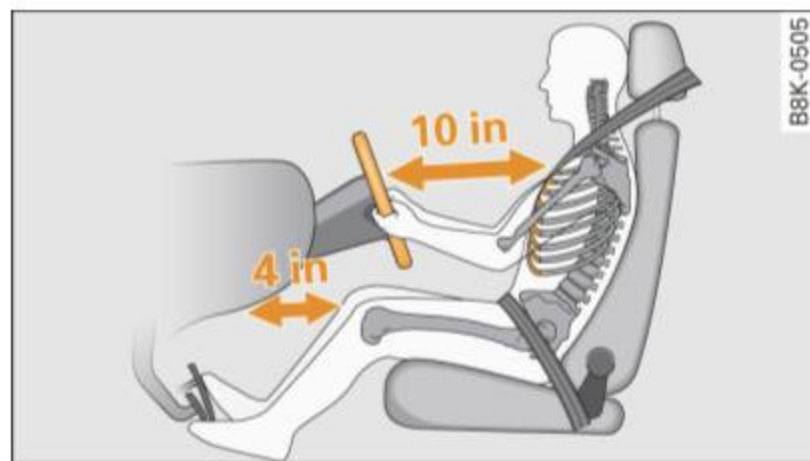


Fig. 158 The correct distance between driver and steering wheel

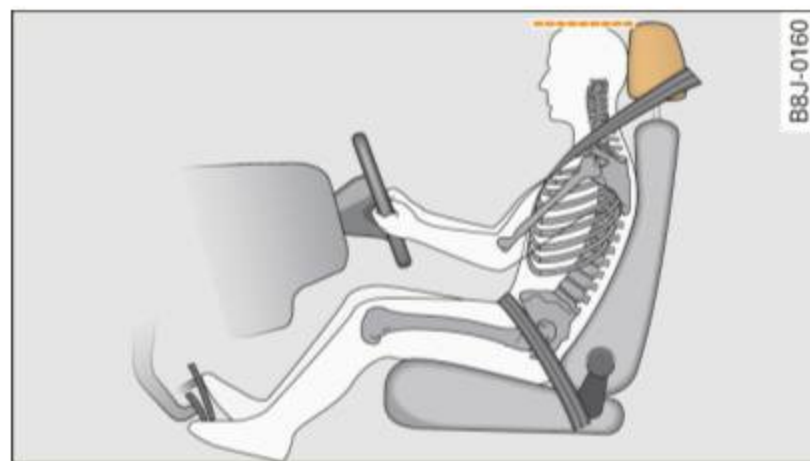


Fig. 159 Correct head restraint position for driver

For your own safety and to reduce the risk of injury in the event of an accident, we recommend that you adjust the driver's seat to the following position:

- Adjust the driver's seat so that you can easily push the pedals all the way to the floor while keeping your knee(s) slightly bent ⇒ ⚠.


- Adjust the angle of the seatback so that it is in an upright position so that your back comes in full contact with it when you drive.
- Adjust the steering wheel so that there is a distance of at least 10 inches (25 cm) between the steering wheel and your breast bone ⇒ fig. 158. If not possible, see your authorized Audi dealer about adaptive equipment.
- Adjust the steering wheel so that the steering wheel and airbag cover points at your chest and not at your face.
- Grasp the top of the steering wheel with your elbow(s) slightly bent.
- Adjust the head restraint so that the upper edge is as even with the top of your head as possible but no lower than eye level and so that it is as close to the back of your head as possible ⇒ fig. 159.
- Fasten and wear safety belts correctly ⇒ *page 167*.
- Always keep both feet in the footwell so that you are in control of the vehicle at all times.

For detailed information on how to adjust the driver's seat, see ⇒ *page 81*.

⚠ WARNING

Drivers who are unbelted, out of position or too close to the airbag can be seriously injured by an airbag as it unfolds. To help reduce the risk of serious personal injury:

- Always adjust the driver's seat and the steering wheel so that there are at least 10 inches (25 cm) between your breastbone and the steering wheel.
- Always hold the steering wheel on the outside of the steering wheel rim with your hands at the 9 o'clock and 3 o'clock positions

 WARNING (continued)


to help reduce the risk of personal injury if the driver's airbag inflates.

- Never hold the steering wheel at the 12 o'clock position or with your hands at other positions inside the steering wheel rim or on the steering wheel hub. Holding the steering wheel the wrong way can cause serious injuries to the hands, arms and head if the driver's airbag deploys.
- Pointing the steering wheel toward your face decreases the ability of the supplemental driver's airbag to protect you in a collision.
- Always sit in an upright position and never lean against or place any part of your body too close to the area where the airbags are located.
- Before driving, always adjust the front seats and head restraints properly and make sure that all passengers are properly restrained.
- Never adjust the seats while the vehicle is moving. Your seat may move unexpectedly and you could lose control of the vehicle.
- Never drive with the backrest reclined or tilted far back! The farther the backrests are tilted back, the greater the risk of injury due to incorrect positioning of the safety belt and improper seating position.
- Children must always ride in child safety seats ⇒ *page 197*. Special precautions apply when installing a child safety seat on the front passenger seat ⇒ *page 172*. ■

Proper seating position for the front passenger

The proper front passenger seating position is important for safe, relaxed driving.


For your own safety and to reduce the risk of injury in the event of an accident, we recommend that you adjust the seat for the front passenger to the following position:

- Move the front passenger seat back as far as possible. There must be a minimum of 10 inches (25 cm) between the breastbone and the instrument panel ⇒ .
- Adjust the angle of the seatback so that it is in an upright position and your back comes in full contact with it whenever the vehicle is moving.
- Adjust the head restraint so that the upper edge is as even with the top of your head as possible but not lower than eye level and so that it is as close to the back of your head as possible.
- Keep both feet flat on the floor in front of the front passenger seat.
- Fasten and wear safety belts correctly ⇒ *page 167*.

For detailed information on how to adjust the front passenger's seat, see ⇒ *page 78*.

 WARNING

Front seat passengers who are unbelted, out of position or too close to the airbag can be seriously injured or killed by the airbag as it unfolds. To help reduce the risk of serious personal injury:

 WARNING (continued)

- Passengers must always sit in an upright position and never lean against or place any part of their body too close to the area where the airbags are located.
- Passengers who are unbelted, out of position or too close to the airbag can be seriously injured by an airbag as it unfolds with great force in the blink of an eye.
- Always make sure that there are at least 10 inches (25 cm) between the front passenger's breastbone and the instrument panel.
- Each passenger must always sit on a seat of their own and properly fasten and wear the safety belt belonging to that seat.
- Before driving, always adjust the front passenger seat and head restraint properly.
- Always keep your feet on the floor in front of the seat. Never rest them on the seat, instrument panel, out of the window, etc. The airbag system and safety belt will not be able to protect you properly and can even increase the risk of injury in a crash.
- Never drive with the backrest reclined or tilted far back! The farther the backrests are tilted back, the greater the risk of injury due to incorrect positioning of the safety belt and improper seating position.
- Children must always ride in child safety seats ⇒ *page 197*. Special precautions apply when installing a child safety seat on the front passenger seat ⇒ *page 172*. ■

Proper seating positions for passengers in rear seats

Rear seat passengers must sit upright with both feet on the floor consistent with their physical size and be properly restrained whenever the vehicle is in use.

To reduce the risk of injury caused by an incorrect seating position in the event of a sudden braking maneuver or an accident, your passengers on the rear bench seat must always observe the following:

- Make sure that the seatback is securely latched in the upright position ⇒ *page 89*.
- Keep both feet flat in the footwell in front of the rear seat.
- Fasten and wear safety belts properly ⇒ *page 167*.
- Make sure that children are always properly restrained in a child restraint that is appropriate for their size and age ⇒ *page 197*.

 WARNING

Passengers who are improperly seated on the rear seat can be seriously injured in a crash.

- Each passenger must always sit on a seat of their own and properly fasten and wear the safety belt belonging to that seat.
- Safety belts only offer maximum protection when the seatback is securely latched in the upright position and the safety belts are properly positioned on the body. By not sitting upright, a rear seat passenger increases the risk of personal injury from improperly positioned safety belts!
- Always adjust the head restraint properly so that it can give maximum protection. ■

Proper adjustment of head restraints

Correctly adjusted head restraints are an important part of your vehicle's occupant restraint system and can help to reduce the risk of injuries in accident situations.

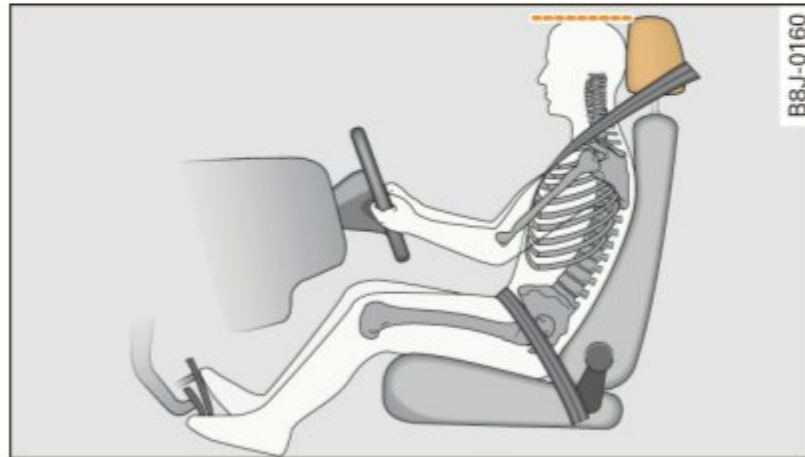


Fig. 160 Correctly adjusted head restraint viewed from the side

The head restraints must be correctly adjusted to achieve the best protection.

- Adjust the head restraint so that the upper edge of the restraint is level with the top of your head, but no lower than eye level and so it is as close to the back of your head as possible ⇒ *page 157, fig. 160.*

Adjusting head restraints ⇒ *page 85.*

WARNING

Driving without head restraints or with improperly adjusted head restraints increases the risk of serious injuries in a collision. To help reduce the risk of injury:

- Always drive with the head restraints in place and properly adjusted.
- Every person in the vehicle must have a properly adjusted head restraint.


WARNING (continued)

- Always make sure each person in the vehicle properly adjusts their head restraint. Each head restraint must be adjusted according to occupants' size so that the upper edge is as even with the top of the person's head, but no lower than eye level and so it is as close to the back of to the head as possible.
- Never attempt to adjust head restraint while driving. If you have driven off and must adjust the driver headrest for any reason, first stop the vehicle safely before attempting to adjust the head restraint.
- Children must always be properly restrained in a child restraint that is appropriate for their age and size ⇒ *page 197.* ■

Examples of improper seating positions

The occupant restraint system can only reduce the risk of injury if vehicle occupants are properly seated.

Improper seating positions can cause serious injury or death. Safety belts can only work when they are properly positioned on the body. Improper seating positions reduce the effectiveness of safety belts and will even increase the risk of injury and death by moving the safety belt to critical areas of the body. Improper seating positions also increase the risk of serious injury and death when an airbag deploys and strikes an occupant who is not in the proper seating position. A driver is responsible for the safety of all vehicle occupants and especially for children. Therefore:

- Never allow anyone to assume an incorrect seating position when the vehicle is being used ⇒ .

The following bulletins list only some sample positions that will increase the risk of serious injury and death. Our hope is that these ►

examples will make you more aware of seating positions that are dangerous.

Therefore, whenever the vehicle is moving:

- never stand up in the vehicle
- never stand on the seats
- never kneel on the seats
- never ride with the seatback reclined
- never lie down on the rear seat
- never lean up against the instrument panel
- never sit on the edge of the seat
- never sit sideways
- never lean out the window
- never put your feet out the window
- never put your feet on the instrument panel
- never rest your feet on the seat cushion or back of the seat
- never ride in the footwell
- never ride in the cargo area

WARNING

Improper seating positions increase the risk of serious personal injury and death whenever a vehicle is being used.

- **Always make sure that all vehicle occupants stay in a proper seating position and are properly restrained whenever the vehicle is being used. ■**

Driver and passenger side footwell

Important safety instructions

WARNING

Always make sure that the knee airbag can inflate without interference. Objects between yourself and the airbag can increase the risk of injury in an accident by interfering with the way the airbag deploys or by being pushed into you as the airbag deploys.

- **No persons (children) or animals should ride in the footwell in front of the passenger seat. If the airbag deploys, this can result in serious or fatal injuries.**
- **No objects of any kind should be carried in the footwell area in front of the driver's or passenger's seat. Bulky objects (shopping bags, for example) can hamper or prevent proper deployment of the airbag. Small objects can be thrown through the vehicle if the airbag deploys and injure you or your passengers. ■**

Pedal area

Pedals

The pedals must always be free to move and must never be interfered with by a floor mat or any other object.

Make sure that all pedals move freely without interference and that nothing prevents them from returning to their original positions.

Only use floor mats that leave the pedal area free and can be secured with floor mat fasteners.

If a brake circuit fails, increased brake pedal travel is required to bring the vehicle to a full stop. ►


WARNING

Pedals that cannot move freely can cause loss of vehicle control and increase the risk of serious injury.

- Never place any objects in the driver's footwell. An object could get into the pedal area and interfere with pedal function. In case of sudden braking or an accident, you would not be able to brake or accelerate!
- Always make sure that nothing can fall or move into the driver's footwell. ■

Floor mats on the driver side

Always use floor mats that can be securely attached to the floor mat fasteners and do not interfere with the free movement of the pedals.

- Make sure that the floor mats are properly secured and cannot move and interfere with the pedals ⇒ .

Use only floor mats that leave the pedal area unobstructed and that are firmly secured so that they cannot slip out of position. You can obtain suitable floor mats from your authorized Audi dealer.

Floor mat fasteners are installed in your Audi.

Floor mats used in your vehicle must be attached to these fasteners. Properly securing the floor mats will prevent them from sliding into positions that could interfere with the pedals or impair safe operation of your vehicle in other ways.

WARNING

Pedals that cannot move freely can result in a loss of vehicle control and increase the risk of serious personal injury.

- Always make sure that floor mats are properly secured.

WARNING (continued)

- Never place or install floor mats or other floor coverings in the vehicle that cannot be properly secured in place to prevent them from slipping and interfering with the pedals or the ability to control the vehicle.
- Never place or install floor mats or other floor coverings on top of already installed floor mats. Additional floor mats and other coverings will reduce the size of the pedal area and interfere with the pedals.
- Always properly reinstall and secure floor mats that have been taken out for cleaning.
- Always make sure that objects cannot fall into the driver footwell while the vehicle is moving. Objects can become trapped under the brake pedal and accelerator pedal causing a loss of vehicle control. ■

Stowing luggage

Loading the luggage compartment

All luggage and other objects must be properly stowed and secured in the luggage compartment.

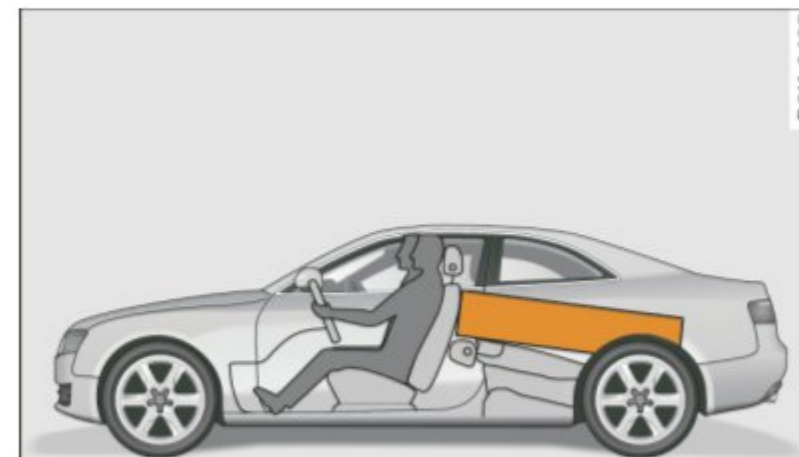


Fig. 161 Safe load positioning: place heavy objects as low and as far forward as possible. ►

Loose items in the luggage compartment can shift suddenly, changing vehicle handling characteristics. Loose items can also increase the risk of serious personal injury in a sudden vehicle maneuver or in a collision.

- Distribute the load evenly in the luggage compartment.
- Always place and properly secure heavy items in the luggage compartment as low and as far forward as possible ⇒ fig. 161.
- Secure luggage using the tie-downs provided ⇒ *page 87*.
- Make sure that the rear seat back is securely latched in place.

WARNING

Improperly stored luggage or other items can fly through the vehicle causing serious personal injury in the event of hard braking or an accident. To help reduce the risk of serious personal injury:

- Always put objects, for example, luggage or other heavy items in the luggage compartment.
- Always secure objects in the luggage compartment using the tie-down eyelets and suitable straps.

WARNING

Heavy loads will influence the way your vehicle handles. To help reduce the risk of a loss of control leading to serious personal injury:

- Always keep in mind when transporting heavy objects, that a change in the center of gravity can also cause changes in vehicle handling:
 - Always distribute the load as evenly as possible.

WARNING (continued)

- Place heavy objects as far forward in the luggage compartment as possible.
- Never exceed the Gross Axle Weight Rating or the Gross Vehicle Weight Rating specified on the safety compliance sticker on the left door jamb. Exceeding permissible weight standards can cause the vehicle to slide and handle differently.
- Please observe information on safe driving ⇒ *page 152*.

WARNING

To help prevent poisonous exhaust gas from being drawn into the vehicle, always keep the rear lid closed while driving.

- Never transport objects larger than those fitting completely into the luggage area because the rear lid cannot be fully closed.
- If you absolutely must drive with the rear lid open, observe the following notes to reduce the risk of poisoning:
 - Close all windows,
 - Close the panorama roof*,
 - Open all air outlets in the instrument panel,
 - Switch off the air recirculation,
 - Set the fresh air fan to the highest speed.

WARNING

Always make sure that the doors, all windows, the panorama roof* and the rear lid are securely closed and locked to reduce the risk of injury when the vehicle is not being used.

- After closing the rear lid, always make sure that it is properly closed and locked.
- Never leave your vehicle unattended especially with the rear lid left open. A child could crawl into the vehicle through the luggage compartment and close the rear lid becoming trapped and unable

⚠ WARNING (continued)

to get out. Being trapped in a vehicle can lead to serious personal injury.

- **Never let children play in or around the vehicle.**
- **Never let passengers ride in the luggage compartment. Vehicle occupants must always be properly restrained in one of the vehicle's seating positions.**

i Tips

- Air circulation helps to reduce window fogging. Stale air escapes to the outside through vents in the trim panel. Be sure to keep these slots free and open.
- The tire pressure must correspond to the load. The tire pressure is shown on the tire pressure label. On USA vehicles, the tire pressure label is located on the driver's side B-pillar. On Canada vehicles, the tire pressure label is located either on the driver's side B-pillar or inside the fuel filler flap. The tire pressure label lists the recommended cold tire inflation pressures for the vehicle at its maximum capacity weight and the tires that were on your vehicle at the time it was manufactured. For recommended tire pressures for normal load conditions, please see chapter ⇒ *page 280*. ■

Tie-downs

The luggage compartment is equipped with four tie-downs to secure luggage and other items.

Use the tie-downs to secure your cargo properly ⇒ *page 159*, "Loading the luggage compartment".

In a collision, the laws of physics mean that even smaller items that are loose in the vehicle will become heavy missiles that can cause serious injury. Items in the vehicle possess energy which vary with vehicle speed and the weight of the item. Vehicle speed is the most significant factor.

For example, in a frontal collision at a speed of 30 mph (48 km/h), the forces acting on a 10-lb (4.5 kg) object are about 20 times the normal weight of the item. This means that the weight of the item would suddenly be about 200 lbs. (90 kg). You can imagine the injuries that a 200 lbs. (90 kg) item flying freely through the passenger compartment could cause in a collision like this.

⚠ WARNING

Weak, damaged or improper straps used to secure items to tie-downs can fail during hard braking or in a collision and cause serious personal injury.

- **Always use suitable mounting straps and properly secure items to the tie-downs in the luggage compartment to help prevent items from shifting or flying forward as dangerous missiles.**
- **When the rear seat backrest is folded down, always use suitable mounting straps and properly secure items to the tie-downs in the luggage compartment to help prevent items from flying forward as dangerous missiles into the passenger compartment.**
- **Never attach a child safety seat tether strap to a tie-down.** ■

Reporting Safety Defects**Applicable to U.S.A.**

If you believe that your vehicle has a defect which could cause a crash or could cause injury or death, you should immediately inform the National Highway Traffic Safety Administration (NHTSA) in addition to notifying Audi of America, Inc. ▶

If NHTSA receives similar complaints, it may open an investigation, and if it finds that a safety defect exists in a group of vehicles, it may order a recall and remedy campaign. However, NHTSA cannot become involved in individual problems between you, your dealer, or Audi of America, Inc.

To contact NHTSA, you may call the Vehicle Safety Hotline toll-free at:

Tel.: 1-888-327-4236 (TTY: 1-800-424-9153)

or write to:

Administrator
NHTSA
1200 New Jersey Avenue, SE
Washington, D.C. 20590

You can also obtain other information about motor vehicle safety from:

<http://www.safercar.gov>

Applicable to Canada

Canadian customers who wish to report a safety-related defect to Transport Canada, Defect Investigations and Recalls, may telephone the toll free hotline:

Tel.: 1-800-333-0371

or contact Transport Canada by mail at:

Road Safety and Motor Vehicle Regulation
Directorate
Transport Canada
Tower C, Place de Ville,
330 Sparks Street
Ottawa, ON K1A 0N5

For additional road safety information, please visit the Road Safety website at:

<http://www.tc.gc.ca/roadsafety/menu.htm> ■

Safety belts

General notes

Always wear safety belts!

Wearing safety belts correctly saves lives!

This chapter explains why safety belts are necessary, how they work and how to adjust and wear them correctly.

- Read all the information that follows and heed all of the instructions and WARNINGS.

WARNING

Not wearing safety belts or wearing them improperly increases the risk of serious personal injury and death.

- Safety belts are the single most effective means available to reduce the risk of serious injury and death in automobile accidents. For your protection and that of your passengers, always correctly wear safety belts when the vehicle is moving.
- Pregnant women, injured, or physically impaired persons must also use safety belts. Like all vehicle occupants, they are more likely to be seriously injured if they do not wear safety belts. The best way to protect a fetus is to protect the mother - throughout the entire pregnancy. ■

Number of seats

Your Audi has a total of four seating positions: two in the front and two in the rear. Each seating position has a safety belt.

WARNING

Not wearing safety belts or wearing them improperly increases the risk of serious personal injury and death.

- Never strap more than one person, including small children, into any belt. It is especially dangerous to place a safety belt over a child sitting on your lap.
- Never let more people ride in the vehicle than there are safety belts available.
- Be sure everyone riding in the vehicle is properly restrained with a separate safety belt or child restraint. ■

Safety belt warning light

Your vehicle has a warning system for the driver and (on USA models only) front seat passenger to remind you about the importance of buckling-up.





Fig. 162 Safety belt warning light in the instrument cluster - enlarged

Before driving off, always:

- Fasten your safety belt and make sure you are wearing it properly. ▶

- Make sure that your passengers also buckle up and properly wear their safety belts.
- Protect your children with a child restraint system appropriate for the size and age of the children.

The warning light  in the instrument cluster lights up when the ignition is switched on as a reminder to fasten the safety belts. In addition, you will hear a warning sound.

After the ignition is switched on, the warning tone will come on for about 6 seconds along with a  warning light in the instrument cluster if either the driver or (on USA models only) front seat passenger has not fastened their safety belt. As soon as the driver and front seat passenger have fastened the safety belt, the warning tone will stop and the warning light will go out.

If both the driver and front seat passenger have not buckled-up within about 24 seconds after the warning tone has stopped, the warning tone will sound again for about 6 seconds. The warning tone will sound repeatedly for about 6 seconds at 24 second intervals until both the driver and front passenger have buckled-up. The safety belt warning system is active for about 5 minutes and during this time the warning light in the instrument cluster will stay on.

Fasten your safety belt now and make sure that your passengers also properly put on their safety belts. ■

Why safety belts?

Frontal collisions and the law of physics

Frontal crashes create very strong forces for people riding in vehicles.

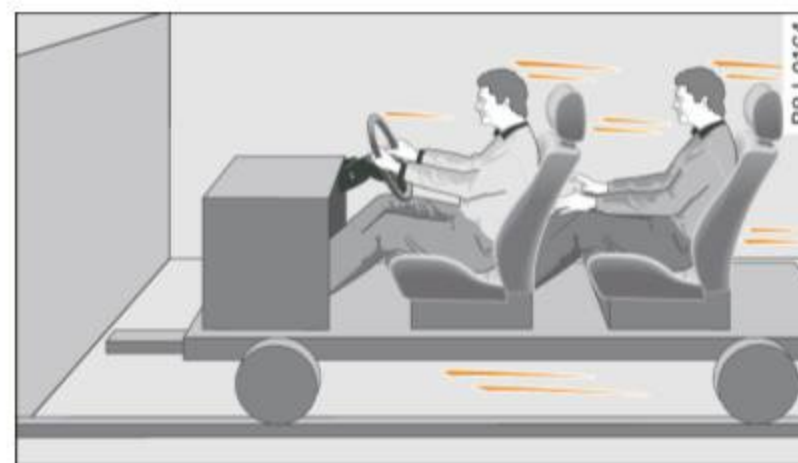


Fig. 163 Unbelted occupants in a vehicle heading for a wall



Fig. 164 The vehicle crashes into the wall

The physical principles are simple. Both the vehicle and the passengers possess energy which varies with vehicle speed and body weight. Engineers call this energy "kinetic energy."

The higher the speed of the vehicle and the greater the vehicle's weight, the more energy that has to be "absorbed" in the crash.

Vehicle speed is the most significant factor. If the speed doubles from 15 to 30 mph (25 to 50 km/h), the energy increases 4 times! ▶

Because the passengers of this vehicle are not using safety belts ⇒ page 164, fig. 163, they will keep moving at the same speed the vehicle was moving just before the crash, until something stops them - here, the wall ⇒ page 164, fig. 164.

The same principles apply to people sitting in a vehicle that is involved in a frontal collision. Even at city speeds of 20 to 30 mph (30 to 50 km/h), the forces acting on the body can reach one ton (2,000 lbs. or 1,000 kg) or more. At greater speeds, these forces are even higher.

People who do not use safety belts are also not attached to their vehicle. In a frontal collision they will also keep moving forward at the speed their vehicle was travelling just before the crash. Of course, the laws of physics don't just apply to frontal collisions, they determine what happens in all kinds of accidents and collisions. ■

What happens to occupants not wearing safety belts?

In crashes unbelted occupants cannot stop themselves from flying forward and being injured or killed. Always wear your safety belts!

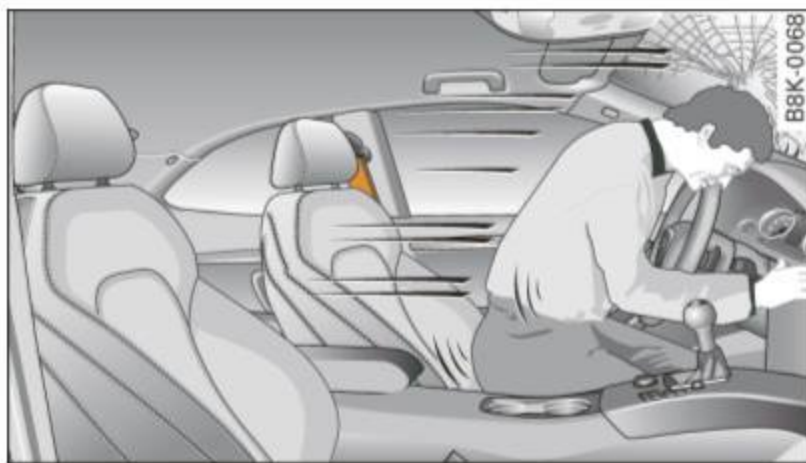


Fig. 165 A driver not wearing a safety belt is violently thrown forward



Fig. 166 A rear passenger not wearing a safety belt will fly forward and strike the driver

Unbelted occupants are not able to resist the tremendous forces of impact by holding tight or bracing themselves. Without the benefit of safety restraint systems, the unrestrained occupant will slam violently into the steering wheel, instrument panel, windshield, or whatever else is in the way ⇒ fig. 165. This impact with the vehicle interior has all the energy they had just before the crash.

Never rely on airbags alone for protection. Even when they deploy, airbags provide only additional protection. Airbags are not supposed to deploy in all kinds of accidents. Although your Audi is equipped with airbags, all vehicle occupants, including the driver, must wear safety belts correctly in order to minimize the risk of severe injury or death in a crash.

Remember too, that airbags will deploy only once and that your safety belts are always there to offer protection in those accidents in which airbags are not supposed to deploy or when they have already deployed. Unbelted occupants can also be thrown out of the vehicle where even more severe or fatal injuries can occur.

It is also important for the rear passengers to wear safety belts correctly. Unbelted passengers in the rear seats endanger not only themselves but also the driver and other passengers ⇒ fig. 166. In a frontal collision they will be thrown forward violently, where they can hit and injure the driver and/or front seat passenger. ■

Safety belts protect

People think it's possible to use the hands to brace the body in a minor collision. It's simply not true!



Fig. 167 Driver is correctly restrained in a sudden braking maneuver

Safety belts used properly can make a big difference. Safety belts help to keep passengers in their seats, gradually reduce energy levels applied to the body in an accident, and help prevent the uncontrolled movement that can cause serious injuries. In addition, safety belts reduce the danger of being thrown out of the vehicle.

Safety belts attach passengers to the car and give them the benefit of being slowed down more gently or “softly” through the “give” in the safety belts, crush zones and other safety features engineered into today's vehicles. By “absorbing” the kinetic energy over a longer period of time, the safety belts make the forces on the body more “tolerable” and less likely to cause injury.

Although these examples are based on a frontal collision, safety belts can also substantially reduce the risk of injury in other kinds of crashes. So, whether you're on a long trip or just going to the corner store, always buckle up and make sure others do, too. Accident statistics show that vehicle occupants properly wearing safety belts have a lower risk of being injured and a much better chance of surviving an accident. Properly using safety belts also greatly increases the ability of the supplemental airbags to do their job in a collision. For this reason, wearing a safety belt is legally required in most countries including much of the United States and Canada.

Although your Audi is equipped with airbags, you still have to wear the safety belts provided. Front airbags, for example, are activated only in some frontal collisions. The front airbags are not activated in all frontal collisions, in side and rear collisions, in roll overs or in cases where there is not enough deceleration through impact to the front of the vehicle. The same goes for the other airbag systems in your Audi. So, always wear your safety belt and make sure everybody in your vehicle is properly restrained! ■

Important safety instructions about safety belts

Safety belts must always be correctly positioned across the strongest bones of your body.

- Always wear safety belts as illustrated and described in this chapter.
- Make sure that your safety belts are always ready for use and are not damaged.

WARNING

Not wearing safety belts or wearing them improperly increases the risk of serious personal injury and death. Safety belts can work only when used correctly.

- **Always fasten your safety belts correctly before driving off and make sure all passengers are correctly restrained.**
- **For maximum protection, safety belts must always be positioned properly on the body.**
- **Never strap more than one person, including small children, into any belt.**
- **Never place a safety belt over a child sitting on your lap.**
- **Always keep feet in the footwell in front of the seat while the vehicle is being driven.**

⚠ WARNING (continued)

- Never let any person ride with their feet on the instrument panel or sticking out the window or on the seat.
- Never remove a safety belt while the vehicle is moving. Doing so will increase your risk of being injured or killed.
- Never wear belts twisted.
- Never wear belts over rigid or breakable objects in or on your clothing, such as eye glasses, pens, keys, etc., as these may cause injury.
- Never allow safety belts to become damaged by being caught in door or seat hardware.
- Do not wear the shoulder part of the belt under your arm or otherwise out of position.
- Several layers of heavy clothing may interfere with correct positioning of belts and reduce the overall effectiveness of the system.
- Always keep belt buckles free of anything that may prevent the buckle from latching securely.
- Never use comfort clips or devices that create slack in the shoulder belt. However, special clips may be required for the proper use of some child restraint systems.
- Torn or frayed safety belts can tear, and damaged belt hardware can break in an accident. Inspect belts regularly. If webbing, bindings, buckles, or retractors are damaged, have belts replaced by an authorized Audi dealer or qualified workshop.
- Safety belts that have been worn and loaded in an accident must be replaced with the correct replacement safety belt by an authorized Audi dealer. Replacement may be necessary even if damage cannot be clearly seen. Anchorages that were loaded must also be inspected.
- Never remove, modify, disassemble, or try to repair the safety belts yourself.

⚠ WARNING (continued)

- Always keep the belts clean. Dirty belts may not work properly and can impair the function of the inertia reel ⇒ *page 251, "Safety belts"*. ■

Safety belts

Fastening safety belts

Seat first - everybody buckle up!



Fig. 168 Belt buckle and tongue on the driver's seat

To provide maximum protection, safety belts must always be positioned correctly on the wearer's body.

- Adjust the front seat and head restraint properly ⇒ *page 78, "General recommendations"*.
- Make sure the seat back of the rear seat bench is in an upright position and securely latched in place before using the belt ⇒ ⚠.
- Hold the belt by the tongue and pull it evenly across the chest and pelvis ⇒ ⚠.

- Insert the tongue into the correct buckle of your seat until you hear it latch securely ⇒ fig. 168.
- Pull on the belt to make sure that it is securely latched in the buckle.

Automatic safety belt retractors

Every safety belt is equipped with an automatic belt retractor on the shoulder belt. This feature locks the belt when the belt is pulled out fast, during hard braking and in an accident. The belt may also lock when you drive up or down a steep hill or through a sharp curve. During normal driving the belt lets you move freely.

Safety belt pretensioners

The safety belts are equipped with a belt pretensioner that helps to tighten the safety belt and remove slack when the pretensioner is activated. The function of the pretensioner is monitored by a warning light ⇒ page 17.

Switchable locking feature

Every safety belt except the one on the driver seat is equipped with a switchable locking feature that **must** be used when the safety belt is used to attach a child safety seat. Be sure to read the important information about this feature ⇒ page 207.

WARNING

Improperly positioned safety belts can cause serious injury in an accident ⇒ page 168, "Safety belt position".

- Safety belts offer optimum protection only when the seat back is upright and belts are properly positioned on the body.
- Always make sure that the rear seat backrest to which the center rear safety belt is attached is securely latched whenever the rear center safety belt is being used. If the backrest is not securely latched, the passenger will move forward with the backrest during sudden braking, in a sudden maneuver and especially in a crash.

WARNING (continued)

- Never attach the safety belt to the buckle for another seat. Attaching the belt to the wrong buckle will reduce safety belt effectiveness and can cause serious personal injury.
- A passenger who is not properly restrained can be seriously injured by the safety belt itself when it moves from the stronger parts of the body into critical areas like the abdomen.
- Always lock the convertible locking retractor when you are securing a child safety seat in the vehicle ⇒ page 209. ■

Safety belt position

Correct belt position is the key to getting maximum protection from safety belts.

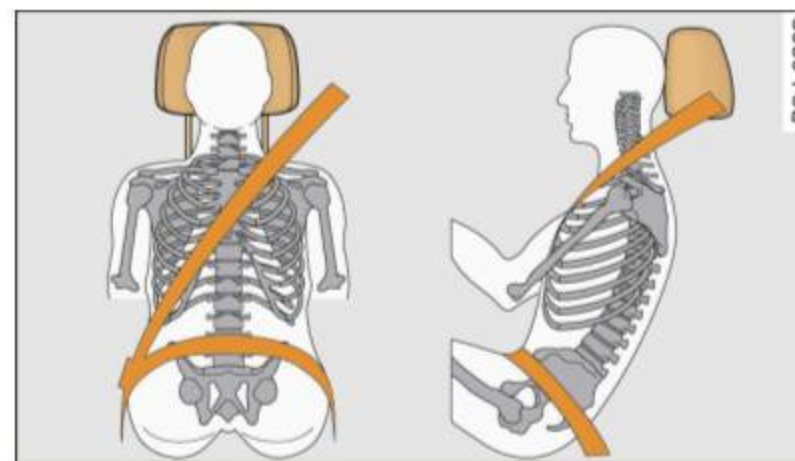


Fig. 169 Head restraint and safety belt position as seen from the side

Standard features on your vehicle help you adjust the position of the safety belt to match your body size.

- height-adjustable front seats.

WARNING

Improperly positioned safety belts can cause serious personal injury in an accident.

⚠ WARNING (continued)

- The shoulder belt portion of the safety belt must be positioned over the middle of the occupant's shoulder and never across the neck or throat.
- The safety belt must lie flat and snug on the occupant's upper body ⇒ fig. 169. Pull on the belt to tighten if necessary.
- The lap belt portion of the safety belt must be positioned as low as possible across pelvis and never over the abdomen. Make sure the belt lies flat and snug ⇒ page 168, fig. 169. Pull on the belt to tighten if necessary.
- A loose-fitting safety belt can cause serious injuries by shifting its position on your body from the strong bones to more vulnerable, soft tissue and cause serious injury.
- Always read and heed all WARNINGS and other important information ⇒ page 166. ■

Pregnant women must also be correctly restrained

The best way to protect the fetus is to make sure that expectant mothers always wear safety belts correctly - throughout the pregnancy.



Fig. 170 Safety belt position during pregnancy

To provide maximum protection, safety belts must always be positioned correctly on the wearer's body ⇒ page 168.

- Adjust the front seat and head restraint correctly ⇒ page 78, "General recommendations".
- Make sure the seat back of the rear seat bench is in an upright position and securely latched in place before using the belt.
- Hold the belt by the tongue and pull it evenly across the chest and pelvis ⇒ fig. 170, ⇒ ⚠.
- Insert the tongue into the correct buckle of your seat until you hear it latch securely ⇒ page 167, fig. 168.
- Pull on the belt to make sure that it is securely latched in the buckle.

⚠ WARNING

Improperly positioned safety belts can cause serious personal injury in an accident.

- Expectant mothers must always wear the lap portion of the safety belt as low as possible across the pelvis and below the rounding of the abdomen.
- Always read and heed all WARNINGS and other important information ⇒ ⚠ in "Fastening safety belts" on page 167. ■

Unfastening safety belts

Unbuckle the safety belt with the red release button only after the vehicle has stopped.



Fig. 171 Releasing the tongue from the buckle

- Push the red release button on the buckle ⇒ fig. 171. The belt tongue will spring out of the buckle ⇒ ⚠.
- Let the belt wind up on the retractor as you guide the belt tongue to its stowed position.

⚠ WARNING

Never unfasten safety belt while the vehicle is moving. Doing so will increase your risk of being injured or killed. ■

Improperly worn safety belts

Incorrectly positioned safety belts can cause severe injuries.

Wearing safety belts improperly can cause serious injury or death. Safety belts can only work when they are correctly positioned on the body. Improper seating positions reduce the effectiveness of safety belts and will even increase the risk of injury and death by moving the safety belt to critical

areas of the body. Improper seating positions also increase the risk of serious injury and death when an airbag deploys and strikes an occupant who is not in the correct seating position. A driver is responsible for the safety of all vehicle occupants and especially for children. Therefore:

- Never permit anyone to assume an incorrect sitting position in the vehicle while traveling ⇒ ⚠.

⚠ WARNING

Improperly worn safety belts increase the risk of serious personal injury and death whenever a vehicle is being used.

- Always make sure that all vehicle occupants are correctly restrained and stay in a correct seating position whenever the vehicle is being used.
- Always read and heed all WARNINGS and other important information ⇒ page 166. ■

Safety belt pretensioners

How safety belt pretensioners work

In front, side and rear-end collisions above a particular severity, safety belts are tensioned automatically.

The safety belts are equipped with safety belt pretensioners. The system is activated by sensors in front, side and rear-end collisions of great severity. This tightens the belt and takes up belt slack ⇒ ⚠ in "Service and disposal of safety belt pretensioner" on page 171. Taking up the slack helps to reduce forward occupant movement during a collision. ▶

 **Note**

Never let the belt remain over a rear seat back that has been folded forward.

 **Tips**

The safety belt pretensioner can only be activated once.

- In minor frontal and side collisions, in rear-end collisions, in a rollover and in accidents involving very little impact force, the safety belt pretensioner are not activated.
- In the case of a side crash, the safety belt pretensioners will activate on the driver's or front passenger's sides only, depending on which side of the vehicle the crash occurs.
- When the safety belt pretensioners are activated, a fine dust is released. This is normal and is not caused by a fire in the vehicle.
- The relevant safety requirements must be observed when the vehicle or components of the system are scrapped. An authorized Audi dealer or qualified workshop is familiar with these regulations and will be pleased to pass on the information to you.
- Be sure to observe all safety, environmental and other regulations if the vehicle or individual parts of the system, particularly the safety belt or airbag, are to be disposed. We recommend you have your authorized Audi dealer perform this service for you. ■

Service and disposal of safety belt pretensioner

The safety belt pretensioners are parts of the safety belts on your Audi. Installing, removing, servicing or repairing of belt pretensioners can damage the safety belt system and prevent it from working correctly in a collision.

There are some important things you have to know to make sure that the effectiveness of the system will not be impaired and that

discarded components do not cause injury or pollute the environment.

 **WARNING**

Improper care, servicing and repair procedures can increase the risk of personal injury and death by preventing a safety belt pretensioner from activating when needed or activating it unexpectedly:

- **The belt pretensioner system can be activated only once. If belt pretensioners have been activated, the system must be replaced.**
- **Never repair, adjust, or change any parts of the safety belt system.**
- **Safety belt systems including safety belt pretensioners cannot be repaired. Special procedures are required for removal, installation and disposal of this system.**
- **For any work on the safety belt system, we strongly recommend that you see your authorized Audi dealer or qualified technician who has an Audi approved repair manual, training and special equipment necessary.**

 **For the sake of the environment**

Undeployed airbag modules and pretensioners might be classified as Perchlorate Material -special handling may apply, see www.dtsc.ca.gov/hazardouswaste/perchlorate. When the vehicle or parts of the restraint system including airbag modules safety belts with pretensioners are scrapped, all applicable laws and regulations must be observed. Your authorized Audi dealer is familiar with these requirements and we recommend that you have your dealer perform this service for you. ■

Airbag system

Important things to know

Importance of wearing safety belts and sitting properly

Airbags are only supplemental restraints. For airbags to do their job, occupants must always properly wear their safety belts and be in a proper seating position.

For your safety and the safety of your passengers, before driving off, always:

- Adjust the driver's seat and steering wheel properly
⇒ *page 154*,
- Adjust the front passenger's seat properly ⇒ *page 79*,
- Wear safety belts properly ⇒ *page 166*,
- Always properly use the proper child restraint to protect children ⇒ *page 197*.

In a collision airbags must inflate within the blink of an eye and with considerable force. The supplemental airbags can cause injuries if the driver or the front seat passenger is not seated properly. Therefore in order to help the airbag to do its job, it is important, both as a driver and as a passenger to sit properly at all times.

By keeping room between your body and the steering wheel and the front of the passenger compartment, the airbag can inflate fully and completely and provide supplemental protection in certain frontal collisions ⇒ *page 154*, "Proper occupant seating positions". For details on the operation of the seat adjustment controls ⇒ *page 81*.

It's especially important that children are properly restrained ⇒ *page 197*.

There is a lot that the driver and the passengers can and must do to help the individual safety features installed in your Audi work together as a system.

Proper seating position is important so that the front airbag on the driver side can do its job. If you have a physical impairment or condition that prevents you from sitting properly on the driver seat with the safety belt properly fastened and reaching the pedals, special modifications to your vehicle may be necessary.

Contact your authorized Audi dealer, or call Audi Customer Relations at 1-800-822-2834.

When the airbag system deploys, a gas generator will fill the airbags, break open the padded covers, and inflate between the steering wheel and the driver and between the instrument panel and the front passenger. The airbags will deflate immediately after deployment so that the front occupants can see through the windshield again without interruption.

All of this takes place in the blink of an eye, so fast that many people don't even realize that the airbags have deployed. The airbags also inflate with a great deal of force and nothing should be in their way when they deploy. Front airbags in combination with properly worn safety belts slow down and limit the occupant's forward movement. Together they help to prevent the driver and front seat passenger from hitting parts of the inside the vehicle while reducing the forces acting on the occupant during the crash. In this way they help to reduce the risk of injury to the head and upper body in the crash. Airbags do not protect the arms or the lower parts of the body.

Both front airbags will not inflate in all frontal collisions. The triggering of the airbag system depends on the vehicle deceleration rate caused by the collision and registered by the electronic control unit. If this rate is below the reference value programmed into the control unit, the airbags will not be triggered, even though the car may be badly damaged as a result of the collision. Vehicle damage, ►

repair costs or even the lack of vehicle damage is not necessarily an indication of whether an airbag should inflate or not.

It is not possible to define a range of vehicle speeds that will cover every possible kind and angle of impact that will always trigger the airbags, since the circumstances will vary considerably between one collision and another. Important factors include, for example, the nature (hard or soft) of the object which the car hits, the angle of impact, vehicle speed, etc. The front airbags will also not inflate in side or rear collisions, or in roll-overs.

Always remember: Airbags will deploy only once, and only in certain kinds of collisions. Your safety belts are always there to offer protection in those situations in which airbags are not supposed to deploy, or when they have already deployed; for example, when your vehicle strikes or is struck by another after the first collision.

This is just one of the reasons why an airbag is a supplementary restraint and is not a substitute for a safety belt. The airbag system works most effectively when used with the safety belts. Therefore, always properly wear your safety belts ⇒ *page 163*.

WARNING

Sitting too close to the steering wheel or instrument panel will decrease the effectiveness of the airbags and will increase the risk of personal injury in a collision.

- Never sit closer than 10 inches (25 cm) to the steering wheel or instrument panel.
- If you cannot sit more than 10 inches (25 cm) from the steering wheel, investigate whether adaptive equipment may be available to help you reach the pedals and increase your seating distance from the steering wheel.
- If you are unrestrained, leaning forward, sitting sideways or out of position in any way, your risk of injury is much higher.
- You will also receive serious injuries and could even be killed if you are up against the airbag or too close to it when it inflates - even with an Advanced Airbag.

WARNING (continued)

- To reduce the risk of injury when an airbag inflates, always wear safety belts properly ⇒ *page 167, "Safety belts"*.
- Always make certain that children age 12 or younger always ride in the rear seat. If children are not properly restrained, they may be severely injured or killed when an airbag inflates.
- Never let children ride unrestrained or improperly restrained in the vehicle. Adjust the front seats properly.
- Never ride with the backrest reclined.
- Always sit as far as possible from the steering wheel or the instrument panel ⇒ *page 154*.
- Always sit upright with your back against the backrest of your seat.
- Never place your feet on the instrument panel or on the seat. Always keep both feet on the floor in front of the seat to help prevent serious injuries to the legs and hips if the airbag inflates.
- Never recline the front passenger's seat to transport objects. Items can also move into the area of the side airbag or the front airbag during braking or in a sudden maneuver. Objects near the airbags can become projectiles and cause injury when an airbag inflates.

WARNING

Airbags that have deployed in a crash must be replaced.

- Use only original equipment airbags approved by Audi and installed by a trained technician who has the necessary tools and diagnostic equipment to properly replace any airbag in your vehicle and assure system effectiveness in a crash.
- Never permit salvaged or recycled airbags to be installed in your vehicle. ■

Child restraints on the front seat – some important things to know

- Be sure to read the important information and head the WARNINGS for important details about children and Advanced Airbags ⇒ *page 197*.

Even though your vehicle is equipped with an Advanced Airbag System, make certain that all children, especially those 12 years and younger, always ride in the back seat properly restrained for their age and size. The airbag on the passenger side makes the front seat a potentially dangerous place for a child to ride. The front seat is not the safest place for a child in a forward-facing child safety seat. It can be a very dangerous place for an infant or a child in a rearward-facing seat.

The Advanced Airbag System in your vehicle has been certified to comply with the Requirements of United States Federal Motor Vehicle Safety Standard 208 as applicable at the time your vehicle was manufactured.

The Standard requires the front airbag on the passenger side to be turned off (“suppressed”) if a child up to about one year of age restrained in one of the rear-facing or forward-facing infant restraints listed in Federal Motor Vehicle Safety Standard 208 with which the Advanced Airbag System in your vehicle was certified has been installed on the front passenger seat. For a listing of the child restraints that were used to certify compliance with the US Safety Standard ⇒ *page 199*.

The **PASSENGER AIR BAG OFF** light in the instrument panel tells you when the front Advanced Airbag on the passenger side has been turned off by the electronic control unit.

Each time you turn on the ignition, the **PASSENGER AIR BAG OFF** light will come on for a few seconds and:

- will stay on if the front passenger seat is not occupied,

- will stay on if there is a small child or child restraint on the front passenger seat,
- will go off if the front passenger seat is occupied by an adult as registered by the weight-sensing mat ⇒ *page 183*, “Monitoring the Advanced Airbag System”.

The **PASSENGER AIR BAG OFF** light comes on when the control unit detects a total weight on the front passenger seat that requires the front airbag to be turned off.

If the total weight on the front passenger seat is more than that of a typical 1 year-old child but less than the weight of a small adult, the front airbag on the passenger side can deploy (the **PASSENGER AIR BAG OFF** light does not come on). If the **PASSENGER AIR BAG OFF** light does not come on, the front airbag on the passenger side has not been turned off by the electronic control unit and can deploy if the control unit senses an impact that meets the conditions stored in its memory.

For example, the airbag may deploy if:

- a small child that is heavier than a typical 1 year-old child is on the front passenger seat (regardless of whether the child is in one of the child safety seats listed ⇒ *page 199*), or
- a child who has outgrown child restraints is on the front passenger seat.

If the front passenger airbag is turned off, the **PASSENGER AIR BAG OFF** light comes on in the instrument cluster and stays on.

The front airbag on the passenger side may *not* deploy (the **PASSENGER AIR BAG OFF** light does not illuminate and stay lit) even if a small adult or teenager, or a passenger who is not sitting upright with their back against a non-reclined backrest with their feet on the vehicle floor in front of the seat is on the front passenger seat ⇒ *page 154*, “Proper seating position for the driver”.

If the front passenger airbag deploys, the Federal Standard requires the airbag to meet the “low risk” deployment criteria to reduce the risk of injury through interaction with the airbag. “Low risk” deployment occurs in those crashes that take place at lower decelerations ►

as defined in the electronic control unit ⇒ *page 184, "PASSENGER AIR BAG OFF light"*.

Always remember, a child safety seat or infant carrier installed on the front seat may be struck and knocked out of position by the rapidly inflating passenger's airbag in a frontal collision. The airbag could greatly reduce the effectiveness of the child restraint and even seriously injure the child during inflation.

For this reason, and because the back seat is the safest place for children - when properly restrained according to their age and size - we strongly recommend that children always sit in the back seat ⇒ *page 197, "Child Safety"*.

WARNING

A child in a rearward-facing child safety seat installed on the front passenger seat will be seriously injured and can be killed if the front airbag inflates - even with an Advanced Airbag System.

- The inflating airbag will hit the child safety seat or infant carrier with great force and will smash the child safety seat and child against the backrest, center arm rest, door or roof.
- Always install rear-facing child safety seats on the rear seat.
- If you must install a rearward facing child safety seat on the front passenger seat because of exceptional circumstances and the PASSENGER AIR BAG OFF light does not come on and stay on, immediately install the rear-facing child safety seat in a rear seating position and have the airbag system inspected by your authorized Audi dealer.
- Forward-facing child safety seats installed on the front passenger's seat may interfere with the deployment of the airbag and cause serious personal injury to the child.

WARNING

If, in exceptional circumstances, you must install a forward-facing child restraint on the front passenger's seat:

WARNING (continued)

- Always make sure the forward-facing seat has been designed and certified by its manufacturer for use on a front seat with a passenger front and side airbag.
- Never put the forward-facing child restraint up against or very near the instrument panel.
- Always move the passenger seat into its rearmost position in the seat's fore and aft adjustment range, as far away from the airbag as possible before installing the forward-facing child restraint. The backrest must be adjusted to an upright position.
- Make sure that the PASSENGER AIR BAG OFF light comes on and stays on all the time whenever the ignition is switched on.

WARNING

To reduce the risk of serious injury, make sure that the PASSENGER AIR BAG OFF light will be displayed whenever a child restraint is installed on the front passenger seat and the ignition is switched on.

- If the PASSENGER AIR BAG OFF light does not stay on, perform the checks described ⇒ *page 183, "Monitoring the Advanced Airbag System"*.
- Take the child restraint off the front passenger seat and install it properly at one of the rear seat positions if the PASSENGER AIR BAG OFF light does not stay on.
- Have the airbag system inspected by your authorized Audi dealer immediately.
- Always carefully follow instructions from child restraint manufacturers when installing child restraints.

WARNING

If, in exceptional circumstances, you must install a forward or rearward-facing child restraint on the front passenger's seat:

⚠ WARNING (continued)

- Improper installation of child restraints can reduce their effectiveness or even prevent them from providing any protection.
- An improperly installed child restraint can interfere with the airbag as it deploys and seriously injure or even kill the child – even with an Advanced Airbag System.
- Always carefully follow the manufacturer's instructions provided with the child safety seat or carrier.
- Never place additional items on the seat that can increase the total weight registered by the weight-sensing mat and can cause injury in a crash. ■

Front airbags

Description of front airbags

The airbag system can provide supplemental protection to properly restrained front seat occupants.



Fig. 172 Location of driver airbag: in steering wheel



Fig. 173 Location of front passenger's airbag: in the instrument panel

Your vehicle is equipped with an "Advanced Airbag System" in compliance with United States Federal Motor Vehicle Safety Standard (FMVSS) 208 as applicable at the time your vehicle was manufactured. The system senses the position of the front seats and controls front airbag inflation with a valve, depending on the distance between the respective seat and the steering wheel or instrument panel. The safety belts for the seats have "pretensioners" that help to take slack out of the belt system. The pretensioners are also activated by the electronic control unit for the airbag system.

The front safety belts also have load limiters to help reduce the forces applied to the body in a crash.

The airbag for the driver is in the steering wheel hub ⇒ fig. 172 and the airbag for the front passenger is in the instrument panel ⇒ fig. 173. The general location of the airbags is marked "AIRBAG".


There is a lot you need to know about the airbags in your vehicle. We urge you to read the detailed information about airbags, safety belts and child safety in this and the other chapters that make up the owner's literature. Please be sure to heed the WARNINGS - they are extremely important for your safety and the safety of your passengers, especially infants and small children.

⚠ WARNING

Never rely on airbags alone for protection.

 WARNING (continued)

- Even when they deploy, airbags provide only supplemental protection.
- Airbag work most effectively when used with properly worn safety belts.
- Therefore, always wear your safety belts and make sure that everybody in your vehicle is properly restrained.

 WARNING

A person on the front passenger seat, especially infants and small children, will receive serious injuries and can even be killed by being too close to the airbag when it inflates.

- Although the Advanced Airbag System in your vehicle is designed to turn off the front passenger airbag if an infant or a small child is on the front passenger seat, nobody can absolutely guarantee that deployment under these special conditions is impossible in all conceivable situations that may happen during the useful life of your vehicle.
- The Advanced Airbag System can deploy in accordance with the “low risk” option under the U.S. Federal Standard if a child that is heavier than the typical one-year old child is on the front passenger seat and the other conditions for airbag deployment are met.
- Accident statistics have shown that children are generally safer in the rear seat area than in the front seating position.
- For their own safety, all children, especially 12 years and younger, should always ride in the back properly restrained for their age and size. ■

Advanced front airbag system

Your vehicle is equipped with a front Advanced Airbag System in compliance with United States Federal Motor Vehicle Safety Standard 208 as applicable at the time your vehicle was manufactured.

The front Advanced Airbag System supplements the safety belts to provide additional protection for the driver's and front passenger's heads and upper bodies in frontal crashes. The airbags inflate only in frontal impacts when the vehicle deceleration is high enough.

The front Advanced Airbag System for the front seat occupants is not a substitute for your safety belts. Rather, it is part of the overall occupant restraint system in your vehicle. Always remember that the airbag system can only help to protect you, if you are sitting upright, wearing your safety belt and wearing it properly. This is why you and your passengers must always be properly restrained, not just because the law requires you to be.

The Advanced Airbag System in your vehicle has been certified to meet the “low risk” requirements for 3 and 6 year-old children on the passenger side and very small adults on the driver side. The low risk deployment criteria are intended to help reduce the risk of injury through interaction with the front airbag that can occur, for example, by being too close to the steering wheel and instrument panel when the airbag inflates.

In addition, the system has been certified to comply with the “suppression” requirements of the Safety Standard, to turn off the front airbag for infants 12 months old and younger who are restrained on the front passenger seat in child restraints that are listed in the Standard ⇒ *page 199*, “Child restraints and Advanced Airbags”.

“Suppression” requires the front airbag on the passenger side to be turned off if:

- a child up to about one year of age is restrained on the front passenger seat in one of the rear-facing or forward-facing infant restraints listed in Federal Motor Vehicle Safety Standard 208 with which the Advanced Airbag System in your vehicle was certified. For ►

a listing of the child restraints that were used to certify your vehicle's compliance with the US Safety Standard ⇒ *page 199*,

- weight less than a threshold level stored in the control unit is detected on the front passenger seat.

When a person is detected on the front passenger seat, weighing more than the total weight of a child that is about 1 year old restrained in one of the rear-facing or forward-facing infant restraints (listed in Federal Motor Vehicle Safety Standard 208 with which the Advanced Airbag System in your vehicle was certified), the front airbag on the passenger side may or may not deploy.

The **PASSENGER AIR BAG OFF** light comes on when the electronic control unit detects a total weight on the front passenger seat that requires the front airbag to be turned off. If the **PASSENGER AIR BAG OFF** light does not come on, the front airbag on the passenger side has not been turned off by the control unit and can deploy if the control unit senses an impact that meets the conditions stored in its memory.

If the total weight on the front passenger seat is more than that of a typical 1 year-old, but less than the weight of a small adult, the front airbag on the passenger side may deploy (the **PASSENGER AIR BAG OFF** light does not come on).

For example, the airbag may deploy if:

- a small child that is heavier than a typical 1 year-old child is on the front passenger seat (regardless of whether the child is in one of the child safety seats listed ⇒ *page 199*),
- a child who has outgrown child restraints is on the front passenger seat.

If the front passenger airbag is turned off, the **PASSENGER AIR BAG OFF** light in the center of the instrument panel will come on and stay on.

The front airbag on the passenger side may *not* deploy (the **PASSENGER AIR BAG OFF** light does not illuminate and stay lit) if:

- a small adult or teenager is on the front passenger seat

- a passenger who is not sitting upright with their back against a non-reclined backrest with their feet on the vehicle floor in front of the seat is on the front passenger seat.

If the front passenger airbag deploys, the Federal Standard requires the airbag to meet the "low risk" deployment criteria to help reduce the risk of injury through interaction with the airbag. "Low risk" deployment occurs in those crashes that take place at lower decelerations as defined in the electronic control unit. ⇒ *page 183*

Always remember: Even though your vehicle is equipped with Advanced Airbags, the safest place for children is properly restrained on the back seat. Please be sure to read the important information in the sections that follow and be sure to heed all of the WARNINGS.



WARNING

To reduce the risk of injury when an airbag inflates, always wear safety belts properly.

- If you are unrestrained, leaning forward, sitting sideways or out of position in any way, your risk of injury is much higher.
- You will also receive serious injuries and could even be killed if you are up against the airbag or too close to it when it inflates - even with an Advanced Airbag ⇒ *page 172*.



WARNING

A child in a rearward-facing child safety seat installed on the front passenger seat will be seriously injured and can be killed if the front airbag inflates - even with an Advanced Airbag System.

- Although the Advanced Airbag System in your vehicle is designed to turn off the front airbag when a rearward-facing child restraint has been installed on the front passenger seat, nobody can absolutely guarantee that deployment is impossible in all conceivable situations that may happen during the useful life of your vehicle.

! WARNING (continued)

- The inflating airbag will hit the child safety seat or infant carrier with great force and will smash the child safety seat and child against the backrest, center arm rest, door, or roof.
- Always install rearward-facing child restraints in the back seat.
- If you must install a rearward facing child safety seat on the front passenger seat because of exceptional circumstances and the PASSENGER AIR BAG OFF light does not come on and stay on, immediately install the rear-facing child safety seat in a rear seating position and have the airbag system inspected by your authorized Audi dealer.

! WARNING

If, in exceptional circumstances, you must install a forward-facing child restraint on the front passenger's seat:

- Always make sure the forward-facing seat has been designed and certified by its manufacturer for use on a front seat with a passenger front and side airbag.
- Never put the forward-facing child restraint up against or very near the instrument panel.
- Always move the passenger seat into its rearmost position in the seat's fore and aft adjustment range, as far away from the airbag as possible, before installing the forward-facing child restraint. The backrest must be adjusted to an upright position.
- Make sure that the PASSENGER AIR BAG OFF light comes on and stays on all the time whenever the ignition is switched on. ■

Advanced Airbag System components

The front passenger seat in your vehicle has a lot of very important parts of the Advanced Airbag System in it. These parts include the weight-sensing mat, sensors, wiring, brackets, and more. The func-

tion of the system in the front passenger seat is checked by the electronic control unit when the ignition is on. The control unit monitors the Advanced Airbag System and turns the airbag indicator light on when a malfunction in the system components is detected. The function of the airbag indicator light is described in greater detail below. Because the front passenger seat contains important parts of the Advanced Airbag System, you must take care to prevent it from being damaged. Damage to the seat may prevent the Advanced Airbag for the front passenger seat from doing its job in a crash.

The front Advanced Airbag System consists of the following:

- Crash sensors in the front of the vehicle that measure vehicle acceleration/deceleration to provide information to the Advanced Airbag System about the severity of the crash.
- An electronic control unit, with integrated crash sensors for front and side impacts. The control unit "decides" whether to fire the front airbags based on the information received from the crash sensors. The control unit also "decides" whether the safety belt pretensioners should be activated.
- An Advanced Airbag with gas generator and control valve for the driver inside the steering wheel hub.
- An Advanced Airbag with gas generator and control valve inside the instrument panel for the front passenger.
- A weight-sensing mat under the upholstery padding of the front passenger seat cushion that measures the total weight on the seat. The information registered is sent continuously to the electronic control unit to regulate deployment of the front Advanced Airbag on the passenger side.
- An airbag monitoring system and indicator light in the instrument cluster ⇒ *page 183*.
- A sensor in each front seat registers the distance between the respective seat and the steering wheel or instrument panel. The information registered is sent continuously to the electronic control unit to regulate deployment of the front Advanced Airbags. ▶

- The **PASSENGER AIR BAG OFF** light comes on and stays on in the center of the instrument panel ⇒ *page 184, fig. 175* and tells you when the front Advanced Airbag on the passenger side has been turned off.
- A sensor below the safety belt latch for the front seat passenger to measure the tension on the safety belt. The tension on the safety belt and the weight registered by the weight-sensing mat help the control unit “decide” whether the front airbag for the front passenger seat should be turned off or not ⇒ *page 174, “Child restraints on the front seat – some important things to know”*.
- A sensor in the safety belt latch for the driver and for the front seat passenger that senses whether that safety belt is latched or not and transmits this information to the electronic control unit.

WARNING

Damage to the front passenger seat can prevent the front airbag from working properly.

- **Improper repair or disassembly of the front passenger and driver seat will prevent the Advanced Airbag System from functioning properly.**
- **Repairs to the front passenger seat must be performed by qualified and properly trained workshop personnel.**
- **Never remove the front passenger or driver seat from the vehicle.**
- **Never remove the upholstery from the front passenger seat.**
- **Never disassemble or remove parts from the seat or disconnect wires from it.**
- **Never carry sharp objects in your pockets or place them on the seat. If the weight-sensing mat in the passenger seat is punctured it cannot work properly.**
- **Never carry things on your lap or carry objects on the passenger seat. Such items can increase the weight registered by the weight-sensing mat and send the wrong information to the airbag control unit.**

WARNING (continued)

- **Never store items under the front passenger seat. Parts of the Advanced Airbag System under the passenger seat could be damaged, preventing them and the airbag system from working properly.**
- **Never place seat covers or replacement upholstery that have not been specifically approved by Audi on the front seats.**
- **Seat covers can prevent the Advanced Airbag System from recognizing child restraints or occupants on the front passenger seat and prevent the side airbag in the seat backrest from deploying properly.**
- **Never use cushions, pillows, blankets or similar items on the front passenger seat. The additional padding will prevent the weight-sensing mat in the seat from accurately registering the child restraint or person on the seat and prevent the Advanced Airbag System from functioning properly.**
- **If you must use a child restraint on the front passenger seat and the child restraint manufacturer's instructions require the use of a towel, foam cushion or something else to properly position the child restraint, make certain that the PASSENGER AIR BAG OFF light comes on and stays on whenever the child restraint is installed on the front passenger seat.**
- **If the PASSENGER AIR BAG OFF light does not come on and stay on, immediately install child restraint in a rear seating position and have the airbag system inspected by your authorized Audi dealer. ■**

How the Advanced Airbag System components work together

The front Advanced Airbag System and the side airbags supplement the protection offered by the front three-point safety belts with pretensioners and load limiters and the adjustable head restraints to help reduce the risk of injury in a wide range of accident and

crash situations. Be sure to read the important information about safety and heed the WARNINGS in this chapter.

Deployment of the Advanced Airbag System and the activation of the safety belt pretensioners depend on the deceleration measured by the crash sensors and registered by the electronic control unit. The amount of inflation of the front airbags can also be adapted to the front seat position, depending on the distance between the respective front seat and the steering wheel or instrument panel as registered by sensors in the seats. Crash severity depends on speed and deceleration as well as the mass and stiffness of the vehicle or object involved in the crash.

On the passenger side, regardless of safety belt use, the airbag will be turned off if the weight on the passenger seat is less than the amount programmed in the electronic control unit. The front airbag on the passenger side will also be turned off if one of the child safety seats that has been certified under Federal Motor Vehicle Safety Standard 208 has been recognized on the seat. The **PASSENGER AIR BAG OFF** light comes on and stays on to tell you when the front Advanced Airbag on the passenger side has been turned off ⇒ *page 174*, "Child restraints on the front seat – some important things to know".

WARNING

To reduce the risk of injury when an airbag inflates, always wear safety belts properly.

- **If you are unrestrained, leaning forward, sitting sideways or out of position in any way, your risk of injury is much higher.**
- **You will also receive serious injuries and could even be killed if you are up against the airbag or too close to it when it inflates - even with an Advanced Airbag ⇒ *page 172*. ■**

More important things to know about front airbags



Fig. 174 Inflated front airbags

Safety belts are important to help keep front seat occupants in the proper seated position so that airbags can unfold properly and provide supplemental protection in a frontal collision.

The front airbags are designed to provide additional protection for the chest and face of the driver and the front seat passenger when:

- safety belts are worn properly,
- the seats have been positioned so that the occupant is properly seated as far as possible from the airbag,
- and the head restraints have been properly adjusted.

Because airbags inflate in the blink of an eye with great force, things you have on your lap or have placed on the seat could become dangerous projectiles, and be pushed into you if the airbag inflates.

When an airbag deploys, fine dust is released. This is normal and is not caused by a fire in the vehicle. This dust is made up mostly of a powder used to lubricate the airbags as they deploy. It could irritate skin.

It is important to remember that while the supplemental airbag system is designed to reduce the likelihood of serious injuries, other injuries, for example swelling, bruising and minor abrasions, can also happen when airbags inflate. Airbags do not protect the arms ►

or the lower parts of the body. Front airbags only supplement the three point safety belts in some frontal collisions in which the vehicle deceleration is high enough to deploy the airbags.

Front airbags will not deploy:

- if the ignition is switched off when a crash occurs,
- in side collisions,
- in rear-end collisions,
- in rollovers,
- when the crash deceleration measured by the airbag system is less than the minimum threshold needed for airbag deployment as registered by the electronic control unit.

The front passenger airbag will also not deploy:

- when the front passenger seat is not occupied,
- when the weight on the front passenger seat as sensed by the Advanced Airbag System indicates that the front airbag on the passenger side has to be turned off by the electronic control unit (the **PASSENGER AIR BAG OFF** light comes on and stays on).

WARNING

Sitting in the wrong position can increase the risk of serious injury in crashes.

- **To reduce the risk of injury when the airbags inflate, the driver and passengers must always sit in an upright position, must not lean against or place any part of their body too close to the area where the airbags are located.**
- **Occupants who are unbelted, out of position or too close to the airbag can be seriously injured by an airbag as it unfolds with great force in the blink of an eye ⇒ page 174.**

WARNING

A child in a rearward-facing child safety seat installed on the front passenger seat will be seriously injured and can be killed if the front airbag inflates - even with an Advanced Airbag System.

- **The inflating airbag will hit the child safety seat or infant carrier with great force and will smash the child safety seat and child against the backrest, center arm rest, door or roof.**
- **Always install rear-facing child safety seats on the rear seat.**
- **If you must install a rearward facing child safety seat on the front passenger seat because of exceptional circumstances and the **PASSENGER AIR BAG OFF** light does not come on and stay on, immediately install the rear-facing child safety seat in a rear seating position and have the airbag system inspected by your authorized Audi dealer.**

WARNING

Objects between you and the airbag will increase the risk of injury in a crash by interfering with the way the airbag unfolds or by being pushed into you as the airbag inflates.

- **Never hold things in your hands or on your lap when the vehicle is in use.**
- **Never transport items on or in the area of the front passenger seat. Objects could move into the area of the front airbags during braking or other sudden maneuver and become dangerous projectiles that can cause serious personal injury if the airbags inflate.**
- **Never place or attach accessories or other objects (such as cupholders, telephone brackets, large, heavy or bulky objects) on the doors, over or near the area marked "AIRBAG" on the steering wheel, instrument panel, seat backrests or between those areas and yourself. These objects could cause injury in a crash, especially when the airbags inflate.**
- **Never recline the front passenger's seat to transport objects. Items can also move into the area of the side airbag or the front**

 **WARNING** (continued)

airbag during braking or in a sudden maneuver. Objects near the airbags can become projectiles and cause injury, particularly when the seat is reclined.

 **WARNING**


The fine dust created when airbags deploy can cause breathing problems for people with a history of asthma or other breathing conditions.

- To reduce the risk of breathing problems, those with asthma or other respiratory conditions should get fresh air right away by getting out of the vehicle or opening windows or doors.
- If you are in a collision in which airbags deploy, wash your hands and face with mild soap and water before eating.
- Be careful not to get the dust into your eyes, or into any cuts or scratches.
- If the residue should get into your eyes, flush them with water. ■

Monitoring the Advanced Airbag System

Airbag monitoring indicator light

Two separate indicators monitor the function of the Advanced Airbag System: the airbag monitoring indicator light and the **PASSENGER AIR BAG OFF** light.

The Advanced Airbag System (including the electronic control unit, sensor circuits and system wiring) is monitored continuously to make sure that it is functioning properly whenever the ignition is on. Each time you turn on the ignition, the airbag monitoring indicator light  will come on for a few seconds (self diagnostics).

The system must be inspected when the indicator light :

- does not come on when the ignition is switched on,
- does not go out a few seconds after you have switched on the ignition, or
- comes on while driving.

If an airbag system malfunction is detected, the indicator light will first start flashing to catch the driver's attention and then stay on continuously to serve as a constant reminder to have the system inspected immediately.

If a malfunction occurs that turns the front airbag on the passenger side off, the **PASSENGER AIR BAG OFF** light will come on and stay on whenever the ignition is on.

 **WARNING**

An airbag system that is not functioning properly cannot provide supplemental protection in a frontal crash.

- If the airbag indicator light comes on, it means that there may be something wrong with the Advanced Airbag System. It is possible that the airbag will inflate when it is not supposed to, or will not inflate when it should.
- Have the airbag system inspected immediately by your authorized Audi dealer. ■

PASSENGER AIR BAG OFF light



Fig. 175 Section from the instrument panel: PASSENGER AIR BAG OFF light

The **PASSENGER AIR BAG OFF** light is located in the center of the instrument panel ⇒ fig. 175.

The **PASSENGER AIR BAG OFF** light will come on and stay on to tell you when the front Advanced Airbag on the passenger side has been turned off by the electronic control unit. Each time you turn on the ignition, the **PASSENGER AIR BAG OFF** light will flash for a few seconds and:

- will stay on if the front passenger seat is not occupied,
- will stay on if there is a small child or child restraint on the front passenger seat,
- will go out if the front passenger seat is occupied by an adult as registered by the weight-sensing mat.

The **PASSENGER AIR BAG OFF** light **must come on and stay on** if the ignition is on and

- a car bed has been installed on the front seat, or
- a rearward-facing child restraint has been installed on the front passenger seat, or
- a forward-facing child restraint has been installed on the front passenger seat, or
- the weight registered on the front passenger seat is equal to or less than the combined weight of a typical 1 year-old restrained in

one of the rear-facing or forward-facing infant restraints listed in Federal Motor Vehicle Safety Standard 208 with which the Advanced Airbag System in your vehicle was certified.

If the front passenger seat is not occupied, the front airbag will not deploy, and the **PASSENGER AIR BAG OFF** light will stay on. Never install a rearward-facing child restraint on the front passenger seat, the safest place for a child in any kind of child restraint is at one of the seating positions on the rear seat ⇒ *page 174*, "Child restraints on the front seat – some important things to know" and ⇒ *page 197*, "Child Safety".

If the PASSENGER AIR BAG OFF light comes on when one of the conditions listed above is met, be sure to check the light regularly to make certain that the **PASSENGER AIR BAG OFF** light stays on continuously whenever the ignition is on. If the **PASSENGER AIR BAG OFF** light does not appear and not stay on all the time, stop as soon as it is safe to do so and

- reactivate the system by turning the ignition off and then turning it on again;
- remove and reinstall the child restraint. Make sure that the child restraint is properly installed and that the safety belt for the front passenger seat has been correctly routed around the child restraint as described in the child restraint manufacturer's instructions;
- make sure that the convertible locking feature on the safety belt for the front passenger seat has been activated and that the safety belt has been pulled tight. The belt must not be loose or have loops of slack so that the sensor below the safety belt latch on the seat can do its job ⇒ *page 207*.
- make sure that things that may increase the weight of the child and child safety seat are not being transported on the front passenger seat;
- make sure that the safety belt tension sensor is not blocked. Shake the safety belt latch on the front passenger seat back and forth;
- If a strap or tether is being used to tie the child safety seat to the front passenger seat, make sure that it is not so tight that it causes ►

the weight-sensing mat to measure more weight than is actually on the seat.

If the **PASSENGER AIR BAG OFF** light still does not come on and does not stay on continuously (when the ignition is switched on),

- take the child restraint off the front passenger seat and install it properly at one of the rear seat positions. Have the airbag system inspected by your authorized Audi dealer immediately.
- move the child to a rear seat position and make sure that the child is properly restrained in a child restraint that is appropriate for its size and age.

The **PASSENGER AIR BAG OFF** light should NOT come on when the ignition is on and an adult is sitting in a proper seating position on the front passenger seat. If the **PASSENGER AIR BAG OFF** light comes on and stays on or flashes for about 5 seconds while driving, under these circumstances, make sure that:

- the adult on the front passenger seat is properly seated on the center of the seat cushion with his or her back up against the backrest and the backrest is not reclined ⇒ *page 154, "Proper occupant seating positions"*,
- the adult is not taking weight off the seat by holding on to the passenger assist handle above the front passenger door or supporting their weight on the armrest,
- the safety belt is being properly worn and that there is not a lot of slack in the safety belt webbing,
- accessory seat covers or cushions or other things that may cause an incorrect reading or impression on the weight-sensing mat under the upholstery of the seat have been removed from the front passenger seat,
- a safety belt extender has not been left in the safety belt latch for the front passenger seat.

In addition to the **PASSENGER AIR BAG OFF** light in the center of the instrument panel, the message **PASSENGER AIR BAG OFF** or **PASSENGER AIR BAG ON** will briefly appear in the instrument cluster

display. This is to inform the driver of the current front passenger airbag status. ■

Important safety instructions on monitoring the Advanced Airbag System

WARNING

An airbag system that is not functioning properly cannot provide supplemental protection in a frontal crash.

- If the airbag indicator light comes on, it means that there may be something wrong with the Advanced Airbag System. It is possible that the airbag will inflate when it is not supposed to, or will not inflate when it should.
- Have the airbag system inspected immediately by your authorized Audi dealer.

WARNING

If the front airbag inflates, a child without a child restraint, in a rearward-facing child safety seat or in a forward-facing child restraint that has not been properly installed will be seriously injured and can be killed.

- Even though your vehicle is equipped with an Advanced Airbag System, make certain that all children, especially 12 years and younger, always ride on the back seat properly restrained for their age and size.
- Always install forward or rear-facing child safety seats on the rear seat – even with an Advanced Airbag System.
- If you must install a rearward-facing child safety seat on the front passenger seat because of exceptional circumstances and the **PASSENGER AIR BAG OFF** light does not appear and stay on, immediately install the rear-facing child safety seat in a rear

⚠ WARNING (continued)

seating position and have the airbag system inspected by your authorized Audi dealer.

- A tight tether or other strap on a rearward-facing child restraint attached to the front passenger seat can put too much pressure on the weight-sensing mat in the seat and register more weight than is actually on the seat. The heavier weight registered can make the system work as though an adult were on the seat and deploy the Advanced Airbag when it must be suppressed causing serious or even fatal injury to the child.
- If, in exceptional circumstances, you must install a forward-facing child restraint on the front passenger seat, always move the seat into its rearmost position in the seat's fore and aft adjustment range, as far away from the airbag as possible. The backrest must be adjusted to an upright position. Make sure that the PASSENGER AIR BAG OFF light comes on and stays on all the time whenever the ignition is switched on.

⚠ WARNING

- If the PASSENGER AIR BAG OFF light does not go out when an adult is sitting on the front passenger seat after taking the steps described above, make sure the adult is properly seated and restrained at one of the rear seating positions.
- Have the airbag system inspected by your authorized Audi dealer before transporting anyone on the front passenger seat.

i Tips

If the weight-sensing mat in the front passenger seat detects an empty seat, the front airbag on the passenger side will be turned off, and **PASSENGER AIR BAG OFF** will stay on. ■

Repair, care and disposal of the airbags


Parts of the airbag system are installed at many different places on your Audi. Installing, removing, servicing or repairing a part in an area of the vehicle can damage a part of an airbag system and prevent that system from working properly in a collision.

There are some important things you have to know to make sure that the effectiveness of the system will not be impaired and that discarded components do not cause injury or pollute the environment.

⚠ WARNING

Improper care, servicing and repair procedures can increase the risk of personal injury and death by preventing an airbag from deploying when needed or deploying an airbag unexpectedly:

- Never cover, obstruct, or change the steering wheel horn pad or airbag cover or the instrument panel or modify them in any way.
- Never attach any objects such as cupholders or telephone mountings to the surfaces covering the airbag units.
- For cleaning the horn pad or instrument panel, use only a soft, dry cloth or one moistened with plain water. Solvents or cleaners could damage the airbag cover or change the stiffness or strength of the material so that the airbag cannot deploy and protect properly.
- Never repair, adjust, or change any parts of the airbag system.
- All work on the steering wheel, instrument panel, front seats or electrical system (including the installation of audio equipment, cellular telephones and CB radios, etc.) must be performed by a qualified technician who has the training and special equipment necessary.
- For any work on the airbag system, we strongly recommend that you see your authorized Audi dealer or qualified workshop.
- Never modify the front bumper or parts of the vehicle body. ▶

 **WARNING** (continued)

- **Always make sure that the side airbag can inflate without interference:**
 - **Never install seat covers or replacement upholstery over the front seatbacks that have not been specifically approved by Audi.**
 - **Never use additional seat cushions that cover the areas where the side airbags inflate.**
 - **Damage to the original seat covers or to the seam in the area of the side airbag module must always be repaired immediately by an authorized Audi dealer.**
- **The airbag system can be activated only once. After an airbag has inflated, it must be replaced by an authorized Audi dealer or qualified technician who has the technical information, training and special equipment necessary.**
- **The airbag system can be deployed only once. After an airbag has been deployed, it must be replaced with new replacement parts designed and approved especially for your Audi model version. Replacement of complete airbag systems or airbag components must be performed by qualified workshops only. Make sure that any airbag service action is entered in your Audi Warranty & Maintenance booklet under *AIRBAG REPLACEMENT RECORD*.**
- **In accidents when an airbag is deployed, the vehicle battery separates the alternator and the starter from the vehicle electrical system for safety reasons with a pyrotechnic circuit interrupter.**
 - **Work on the pyrotechnic circuit interrupter must only be performed by a qualified dealer - risk of an accident!**
 - **If the vehicle or the circuit interrupter is scrapped, all applicable safety precautions must be followed.**



For the sake of the environment

Undeployed airbag modules and pretensioners might be classified as Perchlorate Material -special handling may apply, see www.dtsc.ca.gov/hazardouswaste/perchlorate. When the vehicle or parts of the restraint system including airbag modules safety belts with pretensioners are scrapped, all applicable laws and regulations must be observed. Your authorized Audi dealer is familiar with these requirements and we recommend that you have your dealer perform this service for you. ■

Other things that can affect Advanced Airbag performance

Changing the vehicle's suspension system can change the way that the Advanced Airbag System performs in a crash. For example, using tire-rim combinations not approved by Audi, lowering the vehicle, changing the stiffness of the suspension, including the springs, suspension struts, shock absorbers etc. can change the forces that are measured by the airbag sensors and sent to the electronic control unit. Some suspension changes can, for example, increase the force levels measured by the sensors and make the airbag system deploy in crashes in which it would not deploy if the changes had not been made. Other kinds of changes may reduce the force levels measured by the sensors and prevent the airbag from deploying when it should.

The sensors in the safety belt buckle for the driver and front passenger seat tell the electronic control module if the safety belt is latched or not. If the safety belt is being used, the front airbag will deploy at a slightly higher rate of vehicle deceleration than if the safety belt is not being used. Therefore, in a particular collision, it is possible that an airbag will not deploy at a seating position where the safety belt is being used but will inflate at the position where the safety belt is not being used. It is important that nothing interfere with the safety belt buckles so that the sensors can send the correct information about safety belt use to the electronic control unit. ►

WARNING

Changing the vehicle's suspension including use of unapproved tire-rim combinations can change Advanced Airbag performance and increase the risk of serious personal injury in a crash.

- Never install suspension components that do not have the same performance characteristics as the components originally installed on your vehicle.
- Never use tire-rim combinations that have not been approved by Audi.

WARNING

Items stored between the safety belt buckle and the center console can cause the sensors in the buckle to send the wrong information to the electronic control module and prevent the Advanced Airbag System from working properly.

- Always make sure that nothing can interfere with the safety belt buckles and that they are not obstructed.

For the sake of the environment

Undeployed airbag modules and pretensioners might be classified as Perchlorate Material -special handling may apply, see www.dtsc.ca.gov/hazardouswaste/perchlorate. When the vehicle or parts of the restraint system including airbag modules safety belts with pretensioners are scrapped, all applicable laws and regulations must be observed. Your authorized Audi dealer is familiar with these requirements and we recommend that you have your dealer perform this service for you. ■

Knee airbags

Description of knee airbags

The airbag system can provide supplemental protection to properly restrained front seat occupants.

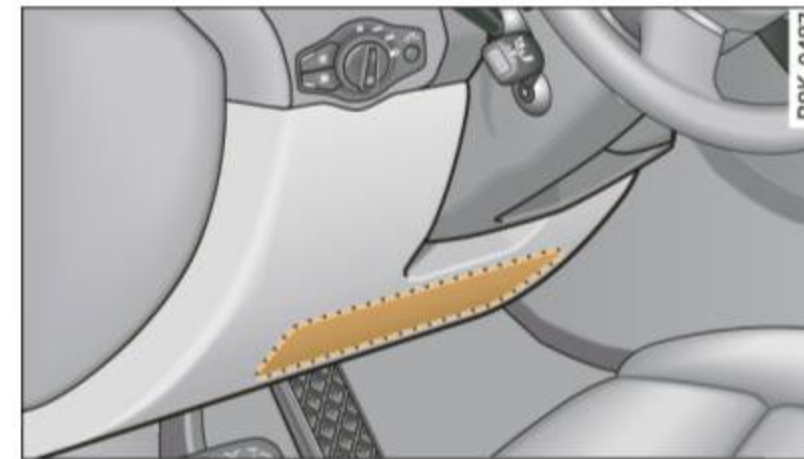


Fig. 176 Driver's knee airbag

The knee airbag for the driver is located in the instrument panel underneath the steering wheel ⇒ fig. 176, the knee airbag for the passenger is at about the same height in the instrument panel underneath the glove compartment.

The knee airbag offers additional protection to the driver's and passenger's knees and upper and lower thigh areas as a supplement to the safety belts.

If the front airbags deploy, the knee airbags also deploy in frontal collisions above a certain severity ⇒ *page 181*, "More important things to know about front airbags".

Besides their normal safety function, safety belts work to help keep the driver or front passenger in position in case of a frontal collision so that the airbags can provide protection.

The airbag system is not a substitute for your safety belt. Rather, it is part of the overall occupant restraint system in your vehicle. Always remember that the airbag system can only help to protect you if you are wearing your safety belt and wearing it properly. This ►

is why you should always wear your safety belt, not just because the law requires you to do so ⇒ *page 163, "General notes"*.

The safety belt buckle for the driver and front seat passenger have switches that tell the airbag control module if the safety belt is being used or not. If the safety belt is being used, the knee airbag will deploy at a slightly higher rate of deceleration than if the belt is not being used. Therefore, in a particular collision, it is possible that an airbag will not deploy at a seating position where the safety belt is being used but will inflate at the position where the safety belt is not being used.

Remember too, airbags will deploy only once and only in certain kinds of accidents - your safety belts are always there to offer protection in those accidents in which airbags are not supposed to deploy or when they have already deployed, for example when your vehicle strikes or is struck by another after the first collision.

This is just one of the reasons why an airbag is not a substitute for the safety belt. The airbag system works most effectively when used with the safety belts. Therefore, always wear your safety belts correctly.

It is important to remember that while the supplemental airbag system is designed to reduce the likelihood of serious injuries, other injuries, for example, swelling, bruising, and minor abrasions can also be associated with airbags.

The knee airbag system basically consists of:

- The electronic control module
- Two inflatable airbags (airbag and gas generator), one for the driver and one for the front passenger
- The airbag indicator light in the instrument panel

The knee airbag system will not deploy:

- when the ignition is turned off
- in front-end collisions when the deceleration measured by the control unit is too low
- in side collisions

- in rear-end collisions
- in rollovers
- in the event of a system malfunction (warning/indicator light illuminated) ⇒ *page 17*.

WARNING

- Safety belts and the airbag system can only provide protection when occupants are in the proper seating position ⇒ *page 181*.
- If the airbag indicator light comes when the vehicle is being used, have the system inspected immediately by your authorized Audi dealer. The airbag may not work properly when the vehicle acceleration in a side collision is high enough to deploy the airbag. See also ⇒ *page 17*. ■

How knee airbags work

The risk of injury to the leg area is reduced by fully deployed knee airbags.



Fig. 177 Inflated airbags protecting in a frontal collision

The knee airbag system has been designed so that the airbags for the driver and front passenger are deployed in certain but not all frontal collisions. ►

If the front airbags deploy, the knee airbags also deploy in frontal collisions above a certain severity.

When the system is deployed, the airbags start to fill with a propellant gas, and inflate between the lower part of the instrument panel and the driver and the lower part of the instrument panel and the front passenger ⇒ *page 181, fig. 174.*

Although they are not a soft pillow, they can cushion the impact and in this way they can help to reduce the risk of injury to the lower extremities.

All this takes place instantaneously, so fast that many people don't even realize that the airbags have deployed. The airbags also inflate with a great deal of force and it is important for occupant safety that nothing should be in their way when they deploy.

Fully inflated airbags in combination with properly worn safety belts slow down and limit the occupant's forward movement and help to reduce the risk. ■

Important safety instructions on the knee airbag system

Airbags are only supplemental restraints. Always wear safety belts correctly and ride in a proper seating position.

There is a lot that you and your passengers must know and do to help the safety belts and airbags to provide supplemental protection.

WARNING

An inflating knee airbag can cause serious injury. Wearing safety belts incorrectly and improper seating positions increase the risk of serious personal injury and death whenever a vehicle is being used.

- **The airbag system cannot protect you properly if you are seated too close to any of the airbag locations. When adjusting**

WARNING (continued)

their seat positions, it is important that both the driver and the front passenger keep their upper bodies and knees at the following minimum safe distances:

- **10 inches (25 cm) between the chest and the steering wheel/instrument panel.**
- **4 inches (10 cm) between the knees and the lower part of the instrument panel.**
- **The risk of personal injury increases if you lean forward or to the side, or if the seat is improperly positioned and you are not wearing your safety belt. The risk increases even more should the airbag deploy.**
- **Always make sure that the knee airbag can inflate without interference. Objects between yourself and the airbag can increase the risk of injury in an accident by interfering with the way the airbag deploys or by being pushed into you as the airbag deploys.**
 - **No persons (children) or animals should ride in the footwell in front of the passenger seat. If the airbag deploys, this can result in serious or fatal injuries.**
 - **No objects of any kind should be carried in the footwell area in front of the driver's or passenger's seat. Bulky objects (shopping bags, for example) can hamper or prevent proper deployment of the airbag. Small objects can be thrown through the vehicle if the airbag deploys and injure you or your passengers.**
- **Make sure there are no cracks, deep scratches or other damage in the area of the instrument panel where the knee airbags are located.**
- **If children are incorrectly seated, their risk of injury increases in the case of an accident ⇒ *page 197, "Child Safety"*. ■**

Side airbags

Description of side airbags

The airbag system can provide supplemental protection to properly restrained occupants.



Fig. 178 Side airbag location in the driver's seat

The side airbags are located in the sides of the front seat backrests ⇒ fig. 178. They are identified by the word "AIRBAG".

The side airbag system basically consists of:

- the electronic control module and external side impact sensors
- the two side airbags located in the sides of the front backrests
- the airbag warning light in the instrument cluster.

The airbag system is monitored electronically to make certain that it is functioning properly at all times. Each time you turn on the ignition, the airbag system indicator light will come on for a few seconds (self diagnostics).

The side airbag system supplements the safety belts and can help to reduce the risk of injury to the driver's and front passenger's upper torso on the side of the vehicle that is struck in a side collision. The airbag deploys only in side impacts and only when the vehicle acceleration registered by the control unit is high enough. If this rate is below the reference value programmed into the control unit, the side airbags will not be triggered, even though the car may

be badly damaged as a result of the collision. It is not possible to define an airbag triggering range that will cover every possible angle of impact, since the circumstances will vary considerably between one collision and another. Important factors include, for example, the nature (hard or soft) of the impacting object, the angle of impact, vehicle speed, etc. ⇒ page 192, "Important safety instructions on the side airbag system".

Aside from their normal safety function, safety belts work to help keep the driver or front passenger in position in the event of a side collision so that the side airbags can provide protection.

The airbag system is *not* a substitute for your safety belt. Rather, it is part of the overall occupant restraint system in your vehicle. Always remember that the side airbag system can only help to protect you if you are wearing your safety belt and wearing it properly. This is another reason why you should always wear your safety belts, not just because the law requires you to do so ⇒ page 163, "General notes".

It is important to remember that while the supplemental side airbag system is designed to reduce the likelihood of serious injuries, other injuries, for example, swelling, bruising, and minor abrasions can also be associated with deployed side airbags. Remember too, side airbags will deploy only once and only in certain kinds of accidents - your safety belts are always there to offer protection.

Vehicle damage, repair costs or even the lack of vehicle damage are not necessarily an indication of over-sensitive or failed airbag activation. In some collisions, both front and side airbags may inflate. Remember too, that airbags will deploy only once and only in certain kinds of collisions - your safety belts are always there to offer protection in those accidents in which airbags are not supposed to deploy or when they have already deployed.

The side airbag system will not deploy:

- when the ignition is turned off
- in side collisions when the acceleration measured by the sensor is too low

- in front-end collisions
- in rear-end collisions
- in rollovers.

In some types of accidents the front airbags, side curtain airbags and side airbags may be triggered together.

WARNING

- **Safety belts and the airbag system will only provide protection when occupants are in the proper seating position** ⇒ *page 192*.
- **If the airbag indicator light comes on when the vehicle is being used, have the system inspected immediately by your authorized Audi dealer. The airbag may not work properly when the vehicle acceleration in a side collision is high enough to activate the airbag.** ■

How supplemental side airbags work

Side airbags deploy instantly and can help reduce the risk of upper torso injuries for occupants who are properly restrained.

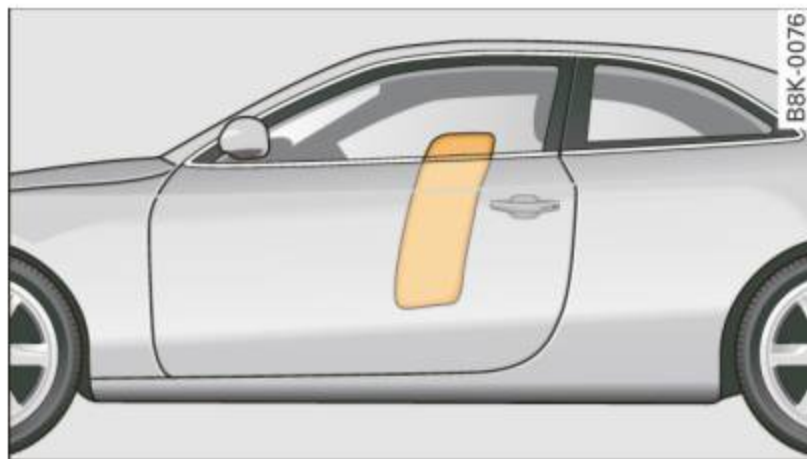


Fig. 179 Inflated side airbags on left side of vehicle

When the system is triggered, the airbag is filled with propellant gas and breaks through a seam in the seat surface area marked

“AIRBAG”. It expands between the side trim panel and the passenger. In order to help provide this additional protection, the side airbag must inflate within a fraction of a second at very high speed and with great force. The supplemental side airbag could injure you if your seating position is not proper or upright or if items are located in the area where the supplemental side airbag expands. This applies especially to children ⇒ *page 197, “Child Safety”*. Supplemental side airbags inflate between the occupant and the door panel on the side of the vehicle that is struck in certain side collision ⇒ fig. 179.

Although they are not a soft pillow, they can “cushion” the impact and in this way they can help to reduce the risk of injury to the upper part of the body.

A fine dust may develop when the airbag deploys. This is normal and does not mean there is a fire in the vehicle. ■

Important safety instructions on the side airbag system

Airbags are only supplemental restraints. Always properly wear safety belts and ride in a proper seating position.

There is a lot that you and your passengers must know and act accordingly to help the safety belts and airbags do their job to provide supplemental protection.

WARNING

An inflating side airbag can cause serious or fatal injury. Improperly wearing safety belts and improper seating positions increase the risk of serious personal injury and death whenever a vehicle is being used.

- **In order to reduce the risk of injury when the supplemental side airbag inflates:**

⚠ WARNING (continued)

- Always sit in an upright position and never lean against the area where the supplemental side airbag is located.
- Never let a child or anyone else rest their head against the side trim panel in the area where the supplemental side airbag inflates.
- Always make sure that safety belts are worn correctly,
- Do not let anyone sitting in the front seat put their hand or any other parts of their body out of the window.
- Always make sure that the side airbag can inflate without interference.
 - Never install seat covers or replacement upholstery over the front seat backs that have not been specifically approved by Audi.
 - Never use additional seat cushions that cover the areas where the side airbags deploy.
 - Damage to the original seat covers or to the seam in the area of the side airbag module must always be repaired immediately by an authorized Audi dealer.
- Objects between you and the airbag can increase the risk of injury in an accident by interfering with the way the airbag unfolds or by being pushed into you as the airbag inflates.
 - Never place or attach accessories or other objects (such as cupholders, telephone brackets, or even large, bulky objects) on the doors, over or near the area marked "AIRBAG" on the seat backrests.
 - Such objects and accessories can become dangerous projectiles and cause injury when the supplemental side airbag deploys.
 - Never carry any objects or pets in the deployment space between them and the airbags or allow children or other passengers to travel in this position.

⚠ WARNING (continued)

- Always use the built-in coat hooks only for lightweight clothing. Never leave any heavy or sharp-edged objects in the pockets that may interfere with side airbag deployment and can cause personal injury in an accident.
- Always prevent the side airbags from being damaged by heavy objects knocking against or hitting the sides of the seatbacks.
- The airbag system can only be triggered once. If the airbag has been triggered, the system must be replaced by an authorized Audi dealership.
- Damage (cracks, deep scratches etc.) to the original seat covers or to the seam in the area of the side airbag module must always be repaired immediately by an authorized Audi dealer.
- If children are seated improperly, their risk of injury increases in the case of an accident ⇒ *page 197, "Child Safety"*.
- Never attempt to modify any components of the airbag system in any way.
- In a side collision, side airbags will not function properly if sensors cannot correctly measure increasing air pressure inside the doors when air escapes through larger, unclosed openings in the door panel.
 - Never drive with interior door trim panels removed.
 - Never drive when parts have been removed from the inside door panel and the openings they leave have not been properly closed.
 - Never drive when loudspeakers in the doors have been removed unless the speaker holes have been properly closed.
 - Always make certain that openings are covered or filled if additional speakers or other equipment is installed in the inside door panels.
 - Always have work on the doors done by an authorized Audi dealer or qualified workshop. ■

Side curtain airbags (SIDEGUARD™)

Description of SIDEGUARD™ airbags

The SIDEGUARD™ airbag system can provide supplemental protection to properly restrained occupants.

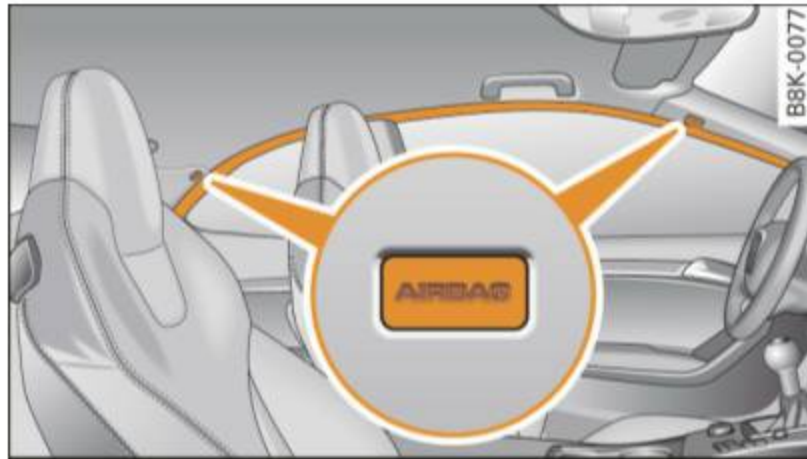


Fig. 180 SIDEGUARD™ system, driver's side: side curtain airbag location

The side curtain airbags are located on both sides of the interior above the front and rear side windows ⇒ fig. 180. They are identified by the word "AIRBAG" on the windshield frame and the center roof pillar.

The side curtain airbag system supplements the safety belts and can help to reduce the risk of injury for occupants' heads and upper torso on the side of the vehicle that is struck in a side collision. The side curtain airbag inflates only in side impacts and only when the vehicle acceleration registered by the control unit is high enough. If this rate is below the reference value programmed into the control unit, the side airbags will not be triggered, even though the car may be badly damaged as a result of the collision. It is not possible to define an airbag triggering range that will cover every possible angle of impact, since the circumstances will vary considerably between one collision and another. Important factors include, for example, the nature (hard or soft) of the impacting object, the angle of impact, vehicle speed, etc. ⇒ *page 195, "How side curtain airbags work"*.

Aside from their normal safety function, safety belts work to help keep the driver or front passenger in position in the event of a collision so that the side curtain airbags can provide protection.

The airbag system is not a substitute for your safety belt. Rather, it is part of the overall occupant restraint system in your vehicle. Always remember that the airbag system can only help to protect you if you are wearing your safety belt and wearing it properly. This is another reason why you should always wear your safety belts, not just because the law requires you to do so ⇒ *page 163, "General notes"*.

It is important to remember that while the side curtain airbag system is designed to help reduce the likelihood of serious injuries, other injuries, for example, swelling, bruising, and minor abrasions can also be associated with these airbags. Remember too, these airbags will deploy only once and only in certain kinds of accidents - your safety belts are always there to offer protection.

The side curtain airbag system basically consists of:

- The electronic control module and external side impact sensors
- The side curtain airbags above the front and rear side windows
- The airbag indicator light in the instrument panel

The airbag system is monitored electronically to make certain it is functioning properly at all times. Each time you turn on the ignition, the airbag system indicator light will come on for a few seconds (self diagnostics).

The side curtain airbag is not activated:

- if the ignition is turned off,
- in side collisions when the acceleration measured by the sensor is too low,
- in front-end collisions,
- in rear-end collisions.

WARNING

- **Safety belts and the airbag system will only provide protection when occupants are in the proper seating position** ⇒ *page 78, "General recommendations"*.
- **If the airbag indicator light comes on when the vehicle is being used, have the system inspected immediately by your authorized Audi dealer. The side curtain airbag may not work properly even when the vehicle acceleration in a side collision is high enough to activate the airbag.** ■

How side curtain airbags work

Side curtain airbags can work together with side airbags to help reduce the risk of head and upper torso injuries for occupants who are properly restrained.

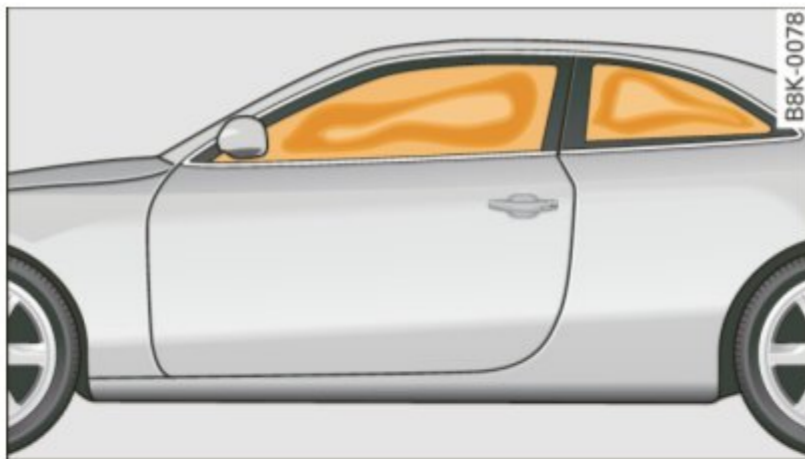


Fig. 181 Illustration of principle: Inflated side curtain airbags on the left side

The side curtain airbags inflate between the occupant and the windows on the side of the vehicle that is struck in a side collision ⇒ fig. 181.

When the system is triggered, the side curtain airbag is filled with propellant gas and breaks through a seam above the front and rear side windows identified by the AIRBAG label. In order to help provide this additional protection, the side curtain airbag must inflate within the blink of an eye at very high speed and with great

force. The side curtain airbag could injure you if your seating position is not proper or upright or if items are located in the area where the supplemental side curtain airbag inflates. This applies especially to children ⇒ *page 197*.

Although they are not a soft pillow, side curtain airbags can "cushion" the impact and in this way they can help to reduce the risk of injury to the head and the upper part of the body.

A fine dust may develop when the airbag deploys. This is quite normal and does not mean there is a fire in the vehicle. ■

Important safety instructions on the side curtain airbag system

Airbags are only supplemental restraints. Always properly wear safety belts and ride in a proper seating position.

There is a lot that you and your passengers must know and do to help the safety belts and airbags do their job to provide supplemental protection.

WARNING

Improperly wearing safety belts and improper seating positions increase the risk of serious personal injury and death whenever a vehicle is being used.

- **Never let occupants place any parts of their bodies in the area from which the side curtain airbags inflate.**
- **Always make sure that the side curtain airbags can inflate without interference. Unsuitable accessories fitted inside the expansion range of a SIDEGUARD head airbag can dangerously interfere with its function. A deploying head airbag develops enough force to catapult any piece of add-on component out of its path of inflation and into the passenger compartment.** An occu- ▶

⚠ WARNING (continued)

pant hit by such a projectile can suffer serious injury or death
⇒ *page 333, "Technical Modifications"*.

- Do not swivel the sun visors to the side if you have any objects clipped onto them (for example pens). If the airbag should deploy, you could be injured by these objects.
- Use the built-in coat hooks only for lightweight clothing. Never leave any heavy or sharp-edged objects in the pockets that may interfere with airbag deployment and can cause personal injury in an accident.
- Never use hangers to hang clothing from the hooks.
- Only use factory-installed sun shades or, in the case of shades installed after the vehicle leaves the factory, only Audi roll-up sunscreens may be used ⇒ *page 332, "Additional accessories and parts replacement"*.
- Always sit in proper seating position and wear safety belts while traveling so that the side curtain airbags can help provide protection.
- The airbag system can only be triggered once. If the airbag has been triggered, the system must be replaced by an authorized Audi dealer or qualified workshop.
- Always have work involving the side curtain airbag system, removal and installation of the airbag components, or other repairs performed by an authorized Audi dealer or qualified workshop. Otherwise the airbag system may not work correctly.
- Never attempt to modify any components of the airbag system in any way. ■

Child Safety

Important things to know

Introduction

The rear seat is generally the safest place in a collision.

The physical principles of what happens when your vehicle is in a crash apply also to children ⇒ *page 165*, "What happens to occupants not wearing safety belts?". But unlike adults their muscles and bones are not fully developed. In many respects children are at greater risk of serious injury in crashes than adults.

Because children's bodies are not fully developed, they require restraint systems especially designed for their size, weight, and body structure. Many countries and all states of the United States and provinces of Canada have laws requiring the use of approved child restraint systems for infants and small children.

In a frontal crash at a speed of 20-35 mph (30-56 km/h) the forces acting on a 13-pound (6 kg) infant will be more than 20 times the weight of the child. This means the weight of the child would suddenly be more than 260 pounds (120 kg). Under these conditions, only an appropriate child restraint properly used can reduce the risk of serious injury. Child restraints must be used properly to be effective. Used improperly, they can increase the risk of serious injury in an accident.

Consult the child safety seat manufacturer's instructions to be sure the seat is right for your child's size ⇒ *page 200*, "Important safety instructions for using child safety seats". Please be sure to read and heed all of the important information and WARNINGS about child safety, Advanced Airbags, and the installation of child restraints in this chapter.

There is a lot you need to know about the Advanced Airbags in your vehicle and how they work when infants and children in child restraints are on the front passenger seat. Because of the large

amount of important information, we cannot repeat it all here. We urge you to read the detailed information in this owner's manual about airbags and the Advanced Airbag System in your vehicle and the very important information about transporting children on the front passenger seat. Please be sure to heed the WARNINGS - they are extremely important for your safety and the safety of your passengers, especially infants and small children.

WARNING

- **Accident statistics have shown that children are generally safer in the rear seat area than in the front seating position. Always restrain any child age 12 and under in the rear.**
- **All vehicle occupants and especially children must be restrained properly whenever riding in a vehicle. An unrestrained or improperly restrained child could be injured by striking the interior or by being ejected from the vehicle during a sudden maneuver or impact. An unrestrained or improperly restrained child is also at greater risk of injury or death through contact with an inflating airbag.**
- **A suitable child restraint properly installed and used at one of the rear seating positions provides the highest degree of protection for infants and small children in most accident situations.**

WARNING

Children on the front seat of any car even with Advanced Airbags can be seriously injured or even killed when an airbag inflates. A child in a rearward-facing child safety seat installed on the front passenger seat will be seriously injured and can be killed if the front airbag inflates.

- **The inflating airbag will hit the child safety seat or infant carrier with great force and will smash the child safety seat and child against the backrest, or door.**

⚠ WARNING (continued)

- **Always install rearward-facing child safety seats on the rear seat.**
- **If you must install a rearward facing child safety seat on the front passenger seat in exceptional circumstances and the PASSENGER AIR BAG OFF light does not come on and stay on, immediately install the rearward-facing child safety seat in a rear seating position and have the airbag system inspected immediately by your authorized Audi dealer.**

⚠ WARNING

If, in exceptional circumstances, you must install a forward-facing child restraint on the front passenger's seat:

- **Always make sure the forward-facing seat has been designed and certified by its manufacturer for use on a front seat with a passenger front and side airbag.**
- **Always follow the manufacturer's instructions provided with the child safety seat or carrier.**
- **Always move the passenger seat into its rearmost position in the seat's fore and aft adjustment range, as far away from the airbag as possible before installing the child restraint. The backrest must be adjusted to an upright position.**
- **Always make sure that the PASSENGER AIR BAG OFF light comes on and stays on all the time whenever the ignition is switched on. ■**

Advanced front airbag system and children

Your vehicle is equipped with a front "Advanced Airbag System" in compliance with United States Federal Motor Vehicle Safety Standard (FMVSS) 208 as applicable at the time your vehicle was manufactured.

The Advanced Airbag system in your vehicle has been certified to meet the "low-risk" requirements for 3 and 6 year-old children on the passenger side and small adults on the driver side. The low risk deployment criteria are intended to reduce the risk of injury through interaction with the airbag that can occur, for example, by being too close to the steering wheel and instrument panel when the airbag inflates. In addition, the system has been certified to comply with the "suppression" requirements of the Safety Standard, to turn off the front airbag for infants up to 12 months who are restrained on the front passenger seat in child restraints that are listed in the Standard.

Even though your vehicle is equipped with an Advanced Airbag system, all children, especially those 12 years and younger, should always ride in the back seat properly restrained for their age and size. The airbag on the passenger side makes the front seat a potentially dangerous place for a child to ride. The front seat is not the safest place for a child in a forward-facing child safety seat. It can be a very dangerous place for an infant or a larger child in a rearward-facing seat. ■

Advanced Airbags and the weight-sensing mat in the front seat

The Advanced Airbag System in your vehicle detects the presence of an infant or child in a child restraint on the front passenger seat using the weight-sensing mat in the seat cushion and the sensor below the safety belt latch on the front passenger seat that measures the tension on the safety belt.

The weight-sensing mat measures total weight of the child and the child safety seat and a child blanket on the front passenger seat. The weight on the front passenger seat is related to the design of the child restraint and its "footprint", the size and shape of the bottom of the child restraint as it sits on the seat. The weight of a child restraint and its "footprint" vary for different kinds of child

restraints and for the different models of the same kind of child restraint offered by child restraint manufacturers.

The weight ranges for the individual types, makes and models of child restraints that the NHTSA has specified in the Safety Standard together with the weight ranges of typical infants and typical 1 year-old child have been stored in the control unit of the Advanced Airbag System. When a child restraint is being used on the front passenger seat with a typical 1 year-old child, the Advanced Airbag System compares the weight measured by the weight sensing mat with the information stored in the electronic control unit.

The electronic control unit also registers the tension on the front passenger safety belt. The tension on the safety belt for the front passenger seat will be different for an adult who is properly using the safety belt as compared to the tension on the belt when it is used to attach a child restraint to the seat. The sensor below the latch for the safety belt for the front seat passenger measures the tension on the belt. The input from this sensor is then used with the weight to “decide”, whether there is a child restraint with a typical 1 year-old child on the front passenger seat and whether or not the airbag must be turned off. ■

Child restraints and Advanced Airbags

Regardless of the child restraint that you use, make sure that it has been certified to meet United States Federal Motor Vehicle Safety Standards and has been certified by its manufacturer for use with an airbag. Always be sure that the child restraint is properly installed at one of the rear seating positions. If in exceptional circumstances you must use it on the front passenger seat, carefully read all of the information on child safety and Advanced Airbags and heed all of the applicable WARNINGS. Make certain that the child restraint is correctly recognized by the weight-sensing mat inside the front passenger seat, that the front passenger airbag is turned off and that the airbag status is always correctly signaled by the **PASSENGER AIR BAG OFF** light.

Many types and models of child restraints have been available over the years, new models are introduced regularly incorporating new and improved designs and older models are taken out of production. Child restraints are not standardized. Child restraints of the same type typically have different weights and sizes and different 'footprints,' the size and shape of the bottom of the child restraint that sits on the seat, when they are installed on a vehicle seat. These differences make it virtually impossible to certify compliance with the requirements for advanced airbags with each and every child restraint that has ever been sold in the past or will be sold over the course of the useful life of your vehicle.

For this reason, the United States National Highway Traffic Safety Administration has published a list of specific type, makes and models of child restraints that must be used to certify compliance of the Advanced Airbag System in your vehicle with the suppression requirements of Federal Motor Vehicle Safety Standard 208. These child restraints are:

A. Car beds, manufactured on or after September 1, 2004:

- Cosco Dream Ride 02-719

B. Rearward facing child restraint systems, manufactured on or after September 1, 2004:

(When the restraint system comes equipped with a removable base, compliance has to be certified with or without the base).

- Britax Handle with Care 191
- Century Assura 4553
- Century Smart Fit 4543
- Cosco Arriva 02727
- Evenflo Discovery Adjust Right 212
- Evenflo First Choice 204
- Graco Infant 8457

C. Forward-facing convertible child restraint systems, manufactured on or after September 1, 2004:

- Britax Roundabout 161
- Britax Expressway
- Century Encore 4612
- Century STE 1000 4416
- Cosco Olympian 02803
- Cosco Touriva 02519
- Evenflo Horizon V 425
- Evenflo Medallion 254
- Safety First Comfort Ride 22-400

WARNING

To reduce the risk of serious injury, make sure that the **PASSENGER AIR BAG OFF** light comes on and stays on whenever a child restraint is installed on the front passenger seat and the ignition is switched on.

- Take the child restraint off the front passenger seat and install it properly at one of the rear seat positions if the **PASSENGER AIR BAG OFF** light does not stay on.
- Have the airbag system inspected by your authorized Audi dealer immediately.

Tips

The child seats listed in categories A to C have been tested by Audi only for the Advanced Airbag function. ■

Important safety instructions for using child safety seats

Correct use of child safety seats substantially reduces the risk of injury in an accident!

As the driver, you are responsible for the safety of everybody in the vehicle, especially children:

- Always use the right child safety seat for each child and always use it properly ⇒ *page 202*.
- Always carefully follow the child safety seat manufacturer's instructions on how to route the safety belt properly through the child safety seat.
- When using the vehicle safety belt to install a child safety seat, you must first activate the convertible locking retractor on the safety belt to prevent the child safety seat from moving ⇒ *page 207*.
- Push the child safety seat down with your full weight to get the safety belt really tight so that the seat cannot move forward or sideways more than one inch (2.5 cm).
- If a strap or tether is being used to tie the child safety seat to the front passenger seat, make sure that it is not so tight that it causes the weight-sensing mat to measure more weight than is actually on the seat.

Always remember: Even though your vehicle is equipped with an Advanced Airbag system, all children, especially those 12 years and younger, should always ride in the back seat properly restrained for their age and size. ►

 **WARNING**

Not using a child safety seat, using the wrong child safety seat or improperly installing a child restraint increases the risk of serious personal injury and death.

- All vehicle occupants and especially children must always be restrained properly whenever riding in a vehicle.
 - An unrestrained or improperly restrained child can be injured or killed by being thrown against the inside of the vehicle or by being ejected from it during a sudden maneuver or impact.
 - An unrestrained or improperly restrained child is at much greater risk of injury or death by being struck by an inflating airbag.
- Commercially available child safety seats are required to comply with U.S. Federal Motor Vehicle Safety Standard (FMVSS) 213 (in Canada CMVSS 213).
 - When buying a child restraint, select one that fits your child and the vehicle.
 - Only use child restraint systems that fully contact the flat portion of the seat cushion. The child restraint must not tip or lean to either side. Audi does not recommend using child safety seats that rest on legs or tube-like frames. They do not provide adequate contact with the seat.
 - Always heed all legal requirements pertaining to the installation and use of child safety seats and carefully follow the instructions provided by the manufacturer of the seat you are using.
- Never allow children under 57 inches (1.5 meters) to wear a normal safety belt. They must always be restrained by a proper child restraint system. Otherwise, they could sustain injuries to the abdomen and neck areas during sudden braking maneuvers or accidents.
- Never let more than one child occupy a child safety seat.

 **WARNING (continued)**

- Never let babies or older children ride in a vehicle while sitting on the lap of another passenger.
 - Holding a child in your arms is never a substitute for a child restraint system.
 - The strongest person could not hold the child with the forces that exist in an accident. The child will strike the interior of the vehicle and can also be struck by the passenger.
 - The child and the passenger can also injure each other in an accident.
- Never install rearward-facing child safety seats or infant carriers on the front passenger seat. A child will be seriously injured and can be killed when the passenger airbag inflates – even with an Advanced Airbag System.
 - The inflating airbag will hit the child safety seat or infant carrier with great force and will smash the child safety seat and child against the backrest, door or roof.
 - Always install rearward-facing child safety seats or infant carriers on the rear seat.
- Forward-facing child safety seats installed on the front passenger's seat can interfere with the airbag when it inflates and cause serious injury to the child. Always install forward-facing child safety seats on the rear seat.
- If exceptional circumstances require the use of a forward-facing child restraint on the front passenger's seat, the child's safety and well-being require that the following special precautions be taken:
 - Make sure the forward-facing seat has been designed and certified by its manufacturer for use on a front seat with a passenger front and side airbag.
 - Always carefully follow the manufacturer's instructions provided with the child safety seat or carrier.

⚠ WARNING (continued)

- Always move the front passenger seat into the rearmost position of the passenger seat's fore and aft adjustment range, and as far away from the airbag as possible before installing the child restraint.
- Always make sure that nothing prevents the front passenger's seat from being moved to the rearmost position in its fore and aft adjustment range.
- Always make sure that the backrest is in the upright position.
- Always buckle the child safety seat firmly in place even if a child is not sitting in it. A loose child safety seat can fly around during a sudden stop or in a collision.
- Always read and heed all WARNINGS whenever using a child restrained in a vehicle is being used ⇒ *page 163, "Safety belts"*, ⇒ *page 172, "Airbag system"* and ⇒ *page 197, "Child Safety"*.

⚠ WARNING

To reduce the risk of serious injury, make sure that the **PASSENGER AIR BAG OFF** light comes on and stays on whenever a child restraint is installed on the front passenger seat and the ignition is switched on.

- Take the child restraint off the front passenger seat and install it properly at one of the rear seat positions if the **PASSENGER AIR BAG OFF** light does not stay on.
- Have the airbag system inspected by your authorized Audi dealer immediately. ■

Child safety seats

Infant seats

Babies and infants up to about one year old and 22 lbs or 10 kg need special rearward-facing child restraints that support the back, neck and head in a crash.

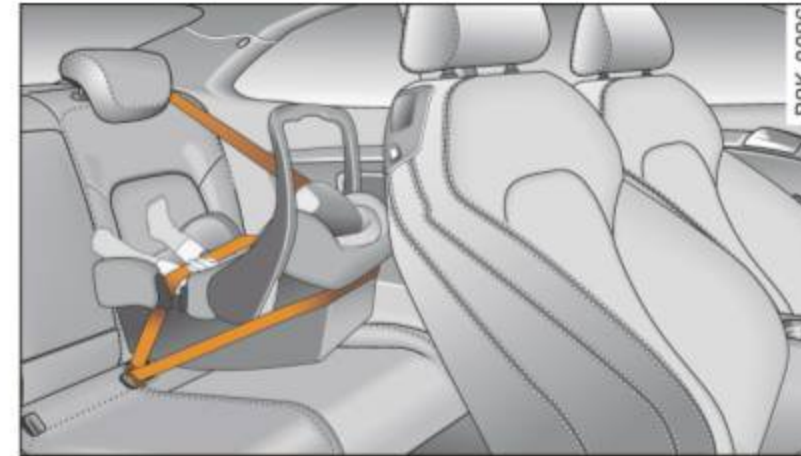


Fig. 182 Rearward-facing infant seat, properly installed on the rear seat

- When using the vehicle safety belt to install a child safety seat, you must first activate the convertible locking retractor on the safety belt to prevent the child safety seat from moving ⇒ *page 207* or install the seat using the LATCH attachments.
- Push the child safety seat down with your full weight to get the safety belt really tight so that the seat cannot move forward or sideways more than one inch (2.5 cm).

Infants up to about one year (22 lbs. or 10 kg) are best protected in special infant carriers and child safety seats designed for their age group. Many experts believe that infants and small children should ride only in special restraints in which the child faces the back of the vehicle. These infant seats support the baby's back, neck and head in a crash. These child safety seats must never be used in the front seat because of the risk of serious injury or death should the airbag deploy in a crash ⇒ *fig. 182*.

WARNING

Not using a child safety seat, using the wrong child safety seat or improperly installing a child restraint increases the risk of serious personal injury and death in a crash.

- Never install rearward-facing child safety seats or infant carriers on the front passenger seat - even with an Advanced Airbag System. A child will be seriously injured and can be killed when the inflating airbag hits the child safety seat or infant carrier with great force and smashes the child safety seat and child against the backrest, or door ⇒ *page 174, "Child restraints on the front seat – some important things to know"*.
- Always install rearward-facing child safety seats or infant carriers on the rear seat.
- Never install a rearward-facing child restraint in the forward-facing direction. Such restraints are designed for the special needs of infants and very small children and cannot protect them properly if the seat is forward-facing.
- If you must install a rearward facing child safety seat on the front passenger seat because of exceptional circumstances and the PASSENGER AIR BAG OFF light does not come on and stay on, immediately install the rearward-facing child safety seat in a rear seating position and have the airbag system inspected by your authorized Audi dealer.
- Always read and heed all WARNINGS whenever using a child restrained in a vehicle is being used ⇒ *page 163, "Safety belts"*, ⇒ *page 172, "Airbag system"* and ⇒ *page 197, "Important things to know"*. ■

Convertible child safety seats

Properly used convertible child safety seats can help protect toddlers and children over age one who weigh between 22 and 40 lbs. (10 and 18 kg) in a crash.

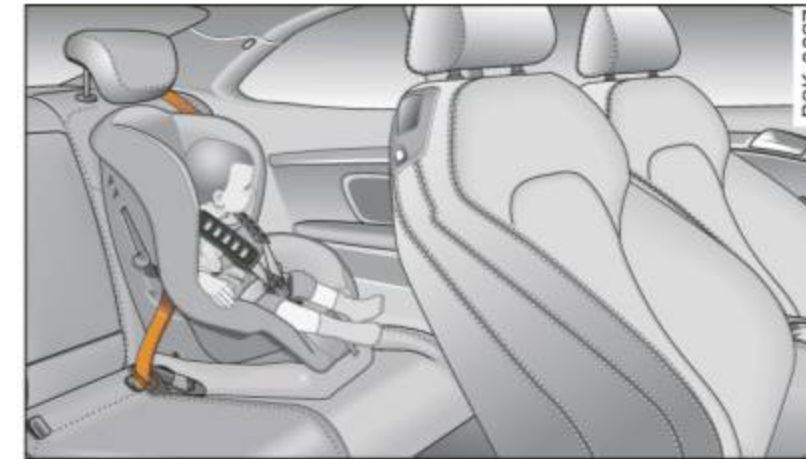


Fig. 183 Rear seat: smaller child in a properly installed forward-facing convertible child safety seat

- When using the vehicle safety belt to install a child safety seat, you must first activate the convertible locking feature on the safety belt to prevent the child safety seat from moving ⇒ *page 207* or install the seat using the LATCH attachment.
- Push the child safety seat down with your full weight to get the safety belt really tight so that the seat cannot move forward or sideways more than one inch (2.5 cm) ⇒ *page 207*.
- If the child safety seat is equipped with a tether strap, attach it to the tether anchors ⇒ *page 213*.

A toddler or child is usually too large for an infant restraint if it is more than one year old and weighs more than 22 lbs. (10 kg).

Toddlers and children who are older than one year up to about 4 years old and weigh more than 22 lbs (10 kg) up to 40 lbs. (18 kg) should be properly restrained in a child safety seat certified for their size and weight ⇒ *fig. 183*. ▶

The airbag on the passenger side makes the front seat a potentially dangerous place for a child to ride. The front seat is not the safest place for a child in a forward-facing child safety seat. It is a very dangerous place for an infant or a larger child in a rearward-facing seat.

WARNING

Not using a child safety seat, using the wrong child safety seat or improperly installing a child restraint increases the risk of serious personal injury and death in a collision or other emergency situation.

- Children on the front seat of any car, even with Advanced Airbags, can be seriously injured or even killed when an airbag inflates. A child in a rearward-facing child safety seat installed on the front passenger seat will be seriously injured and can be killed if the front airbag inflates – even with an Advanced Airbag System.
- The inflating airbag will hit the child safety seat or infant carrier with great force and will smash the child safety seat and child against the backrest, or door.
- Always install rearward-facing child safety seats on the rear seat.
- If you must install a rearward facing child safety seat on the front passenger seat because of exceptional circumstances and the PASSENGER AIR BAG OFF light does not come on and stay on, immediately install the rearward-facing child safety seat in a rear seating position and have the airbag system inspected by your authorized Audi dealer.
- Always read and heed all WARNINGS whenever using a child restrained in a vehicle is being used ⇒ *page 163, "Safety belts"*, ⇒ *page 172, "Airbag system"* and ⇒ *page 197, "Important things to know"*.

WARNING

If exceptional circumstances require the use of a forward-facing child restraint on the front passenger's seat, the child's safety and well-being require that the following special precautions be taken:

- Make sure the forward-facing seat has been designed and certified by its manufacturer for use on a front seat with a passenger front and side airbag.
- Always follow the manufacturer's instructions provided with the child safety seat or carrier.
- Always move the front passenger seat into the rearmost position of the passenger seat's fore and aft adjustment range, and as far away from the airbag as possible before installing the child restraint.
- Always make sure that nothing prevents the front passenger's seat from being moved to the rearmost position in its fore and aft adjustment range.
- Always make sure the backrest is in an upright position.
- Make sure that the PASSENGER AIR BAG OFF light comes on and stays on all the time whenever the ignition is switched on.
- If the light does not stay on, perform the checks ⇒ *page 183, "Monitoring the Advanced Airbag System"*.
- Take the child restraint off the front passenger seat and install it properly at one of the rear seat positions if the PASSENGER AIR BAG OFF light does not stay on whenever the ignition is switched on. ■

Booster seats

Properly used booster seats can help protect children weighing between about 40 lbs. and 80 lbs. (18 kg and 36 kg) who are less than 4 ft. 9 in. tall.



Fig. 184 Rear seat: child properly restrained in a booster seat (with seatback)



Fig. 185 Rear seat: child properly restrained in a booster seat (without seat-back)

The vehicle's safety belts alone will not fit most children until they are at least 4 ft. 9 in. tall and weigh about 80 lbs. (36 kg). Booster seats raise these children up so that the safety belt will pass properly over the stronger parts of their bodies and the safety belt can help protect them in a crash.

- Do not use the convertible locking retractor when using the vehicle's safety belt to restrain a child on a booster seat.

- Always position the shoulder portion of the safety belt midway over the child's shoulder.
- Always make sure that the shoulder portion of the safety belt never rests against or across the child's neck.
- Always make sure that the child can properly wear the lap portion of the belt low across the thighs or pelvis and *never* over the stomach or abdomen.

Children up to about 40 lbs (18 kg) are best protected in child safety seats designed for their age and weight. Experts say that the skeletal structure, particularly the pelvis, of these children is not fully developed, and they should not use the vehicle safety belts ⇒ *page 205, fig. 184* or ⇒ *page 205, fig. 185*.

Children who weigh more than 40 lbs. (18 kg) may generally use the available three point combination lap and shoulder belts when they sit on an appropriate booster seat. Be sure the booster seat meets all applicable safety standards.

Booster seats raise the seating position of the child and reposition both the lap and shoulder parts of the safety belt so that they pass across the child's body in the right places. The routing of the belt over the child's body is very important for the child's protection. This applies whenever a child uses the vehicle's safety belts, even when the child is big enough to use them without a booster seat. Children age 12 and under should *always* ride in the rear seat.

Children should not ride in the front seat unless no other seating position is available because crash statistics show that children are better protected in the rear seat.

In a crash, airbags must inflate within a blink of an eye and with considerable force. In order to do its job, the airbag needs room to inflate so that it will be there to protect the occupant as the occupant moves forward into the airbag.

A vehicle occupant including a child who is out of position and too close to the airbag gets in the way of an inflating airbag. When an ►

occupant is too close, he or she will be struck violently and will receive serious or possibly even fatal injury.

In order for the airbag to offer protection, it is important that all vehicle occupants, especially any children, who must be in the front seat in exceptional circumstances, be properly restrained and as far away from the airbag as possible. By keeping room between the child's or other occupant's body and the front of the passenger compartment, the airbag can inflate fully and completely and provide supplemental protection in certain frontal crashes.

WARNING

Not using a booster seat, using the booster seat improperly, incorrectly installing a booster seat or using the vehicle safety belt improperly increases the risk of serious personal injury and death in a collision or other emergency situation. To help reduce the risk of serious personal injury and/or death:

- Always make sure to position the shoulder portion of the three-point belt over the middle of child's shoulder.
- Never let the shoulder portion of the belt rest against or across the neck, face, chin, or throat of the child.
- Always make sure the lap belt portion of the three-point belt is worn snug and passes as low as possible across the child's pelvis. Never let the belt pass over the soft abdomen.
- Failure to properly route safety belts over a child's body will cause severe injuries in an accident or other emergency situation ⇒ *page 163*.
- Children on the front seat of any car, even with Advanced Airbags, can be seriously injured or even killed when an airbag inflates. A child in a rearward-facing child safety seat installed on the front passenger seat will be seriously injured and can be killed if the front airbag inflates.
- Never let a child stand or kneel on any seat.
- Never let a child ride in the cargo area of your vehicle.

WARNING (continued)

- Always remember that a child leaning forward, sitting sideways or out of position in any way during an accident can be struck by a deploying airbag. This will result in serious personal injury or death.
- If you must install a rearward facing child safety seat on the front passenger seat because of exceptional circumstances the PASSENGER AIR BAG OFF light must come on and stay on, whenever the ignition is switched on.
- If the PASSENGER AIR BAG OFF light does not come on and stay on, perform the checks described ⇒ *page 183*, "Monitoring the Advanced Airbag System".
- Take the child restraint off the front passenger seat and install it properly at one of the rear seat positions if the PASSENGER AIR BAG OFF light does not stay on whenever the ignition is switched on.
- Always read and heed all WARNINGS whenever using a child restrained in a vehicle is being used ⇒ *page 163*, "Safety belts", ⇒ *page 172*, "Airbag system" and ⇒ *page 197*, "Important things to know". ■

Safety belts and older children

Properly worn three point lap and shoulder belt can help protect children weighing more than 80 lbs. (36 kg) and who are at least 4 ft. 9 in. tall.



Fig. 186 Child taller than 4 ft. 9 in. properly restrained on the rear seat

Children who weigh more than about 80 lbs (36 kg) and are at least 4 ft. 9 in. tall can generally use the vehicle's three point lap and shoulder belts ⇒ fig. 186. Children should use a lap belt only in very exceptional situations and only if no child restraint system for the child's size and weight or safer alternative means of transportation of the child is available. In these exceptional situations, the use of a lap belt is better than permitting the child to remain totally unrestrained. But remember: a lap belt cannot provide the same level of protection as a proper child restraint or a three-point lap and shoulder belt if the child is big enough. Also, using a lap belt for younger children, who should be using a child restraint, may violate laws in your state or Province.

Never use a lap belt alone to restrain a child that weighs less than about 80 lbs (36 kg) and who is less than 4'9" tall. Always remember that children do not have the pronounced pelvic structure required for the proper function of lap belts. If a lap belt is only restraint system available, then the child's safety absolutely requires that the lap belt be fastened snugly and as low as possible around the pelvis let a lap belt pass over the child's stomach or abdomen.

WARNING

Using wrong child restraints or improperly installed child restraints can cause serious personal injury or death in a crash.

- Failure to properly route safety belts over a child's body will cause severe injuries in a crash. The lap belt portion of the three point belt as well as any lap belt alone must always pass as low as possible across the pelvis, never over the stomach or abdomen.
- An improperly worn safety belt will not provide the best protection in a crash and may cause serious personal injury. Always make sure that children and other vehicle occupants properly wear available restraint systems. Carefully follow the instructions provided by the manufacturers of child restraints. ■

Installing a child safety seat

Securing a child safety seat using a safety belt

Safety belts for the rear seats and the front passenger's seat can be locked with the convertible locking retractor to properly secure child safety seats.

The safety belts emergency locking retractors for the rear seats safety belts and for the front passenger's seat safety belt have a convertible locking retractor for child restraints. The safety belt must be locked so that belt webbing cannot unreel. The retractor can be activated to lock the safety belt and prevent the safety belt webbing from loosening up during normal driving. A child safety seat can only be properly installed when the safety belt is locked so that the child and child safety seat will stay in place.

Always remember: Even though your vehicle is equipped with an Advanced Airbag system, all children, especially those 12 years and younger, should always ride in the back seat properly restrained for their age and weight. ►

 **WARNING**

Improperly installed child safety seats increase the risk of serious personal injury and death in a collision.

- Always make sure that the safety belt retractor is locked when installing a child safety seat. An unlocked safety belt retractor cannot hold the child safety seat in place during normal driving or in a crash.
- Always buckle the child safety seat firmly in place even if a child is not sitting in it. A loose child safety seat can fly around during a sudden stop or in a collision
- If the backrest is not securely latched, the child and the child restraint will be thrown forward together with the backrest and will strike parts of the vehicle interior. The child can be seriously injured or killed.
- Never install rearward-facing child safety seats or infant carriers on the front passenger seat. A child will be seriously injured and can be killed when the passenger airbag inflates.
- The inflating airbag will hit the child safety seat or infant carrier with great force and will smash the child safety seat and child against the backrest, door or roof.
- Always install rearward-facing child safety seats or infant carriers on the rear seat.
- Forward-facing child safety seats or infant carriers installed on the front passenger's seat may interfere with the deployment of the airbag and cause serious injury to the child.
- It is safer to install a forward-facing child safety seat on the rear seat.
- Always read and heed all WARNINGS whenever using a child restrained in a vehicle is being used ⇒ *page 197*. Special precautions apply when installing a child safety seat on the front passenger seat ⇒ *page 174*, "Child restraints on the front seat – some important things to know".

 **WARNING**


Always take special precautions if you must install a forward or rearward-facing child restraint on the front passenger's seat in exceptional situations:

- Whenever a forward or rearward-facing child restraint is installed on the front passenger seat, the PASSENGER AIR BAG OFF light must come on and stay on whenever the ignition is switched on.
- If the PASSENGER AIR BAG OFF light does not come on and stay on, perform the checks described ⇒ *page 183*, "Monitoring the Advanced Airbag System".
- Take the child restraint off the front passenger seat and install it properly at one of the rear seat positions if the PASSENGER AIR BAG OFF light does not stay on whenever the ignition is switched on.
- Improper installation of child restraints can reduce their effectiveness or even prevent them from providing any protection.
- An improperly installed child restraint can interfere with the airbag as it deploys and seriously injure or even kill the child.
- Always carefully follow the manufacturer's instructions provided with the child safety seat or carrier.
- Never place additional items on the seat that can increase the total weight registered by the weight-sensing mat and can cause injury in a crash.

 **WARNING**

Forward-facing child restraints:

- Always make sure the forward-facing seat has been designed and certified by its manufacturer for use on a front seat with a passenger front and side airbag.
- Never put the forward-facing child restraint up, against or very near the instrument panel.

 WARNING (continued)

- Always move the passenger seat into its rearmost position in the seat's fore and aft adjustment range, as far away from the airbag as possible before installing the forward-facing child restraint. The backrest must be adjusted to an upright position.
- Make sure that the PASSENGER AIR BAG OFF light comes on and stays on all the time whenever the ignition is switched on.

 WARNING


Rearward-facing child restraints:

- A child in a rearward-facing child safety seat installed on the front passenger seat will be seriously injured and can be killed if the front airbag inflates - even with an Advanced Airbag System.
- The inflating airbag will hit the child safety seat or infant carrier with great force and will smash the child safety seat and child against the backrest, door or roof.
- Always be especially careful if you must install a rearward facing child safety seat on the front passenger seat in exceptional circumstances.
- A tight tether strap on a rearward-facing child restraint attached to the front passenger seat can put too much pressure on the weight-mat in the seat and register a heavier weight in the Advanced Airbag System. The heavier weight registered can make the system work as though an adult were on the seat and deploy the Advanced Airbag when it must be suppressed causing serious or even fatal injury to the child.
- Make sure that the PASSENGER AIR BAG OFF light comes on and stays on all the time whenever the ignition is switched on.
- If the PASSENGER AIR BAG OFF light does not come on and stay on, immediately install the rearward-facing child safety seat in a rear seating position and have the airbag system inspected by your authorized Audi dealer. ■

Activating the convertible locking retractor

Use the convertible locking retractor to secure a child restraint.

Always heed the child safety seat manufacturer's instructions when installing a child restraint in your vehicle. To activate the convertible locking retractor:

- Place the child restraint on a seat, preferably on the rear seat.
- Slowly pull the belt **all the way out**.
- Route it around or through the child restraint belt path ⇒ .
- Push the child safety seat down with your full weight to get the safety belt really tight.
- Insert the belt tongue into the buckle for that seating position.
- Guide the safety belt back into the retractor until the belt lies flat and snug on the child safety seat.
- You should hear a “clicking” noise as the belt winds back into the inertia reel. Test the convertible locking retractor by pulling on the belt. You should no longer be able to pull the belt out of the retractor. The convertible locking retractor is now activated.
- Make sure that the red release button is facing away from the child restraint so that it can be unbuckled quickly.
- Pull on the belt to make sure the safety belt is properly tight and fastened so that the seat cannot move forward or sideways more than one inch (2.5 cm). ▶

 **WARNING**

Using the wrong child restraint or an improperly installed child restraint can cause serious personal injury or death in a crash.

- Always make sure that the safety belt retractor is locked when installing a child safety seat. An unlocked safety belt retractor cannot hold the child safety seat in place during normal driving or in a crash.
- Always buckle the child safety seat firmly in place even if a child is not sitting in it. A loose child safety seat can fly around during a sudden stop or in a crash.
- Always make sure the seat backrest to which the child restraint is installed is in an upright position and securely latched into place and cannot fold forward. Otherwise, the seat back with the child safety seat attached to it could fly forward in the event of an accident or other emergency situation.
- Always read and heed all WARNINGS whenever using a child restrained in a vehicle is being used ⇒ *page 197*. Special precautions apply when installing a child safety seat on the front passenger seat ⇒ *page 174*, "Child restraints on the front seat – some important things to know". ■

Deactivating the convertible locking retractor

The convertible locking retractor for child restraints will be deactivated automatically when the belt is wound all the way back into the retractor.

- Press the red button on the safety belt buckle. The belt tongue will pop out of the buckle.
- Guide the belt all the way back into its stowed position.

Always let the safety belt retract completely into its stowed position. The safety belt can now be used as an ordinary safety belt without the convertible locking retractor for child restraints.

If the convertible locking retractor should be activated inadvertently, the safety belt must be unfastened and guided completely back into its stowed position to deactivate this feature. If the convertible locking retractor is not deactivated, the safety belt will gradually become tighter and uncomfortable to wear.

 **WARNING**

Improperly installed child safety seats increase the risk of serious personal injury and death in a collision.

- Never unfasten the safety belt to deactivate the convertible locking retractor for child restraints while the vehicle is moving. You would not be restrained and could be seriously injured in an accident.
- Always read and heed all WARNINGS whenever using a child restrained in a vehicle is being used ⇒ *page 197*. Special precautions apply when installing a child safety seat on the front passenger seat ⇒ *page 174*, "Child restraints on the front seat – some important things to know". ■

Lower anchorages and tethers for children (LATCH)

Location

LATCH is the acronym for Lower Anchors and Tethers for Children and designates a special child safety seat restraint system. In Canada, the terms "top tether" with "lower universal anchorages" (or "lower universal anchorage bars") are used to describe the system.

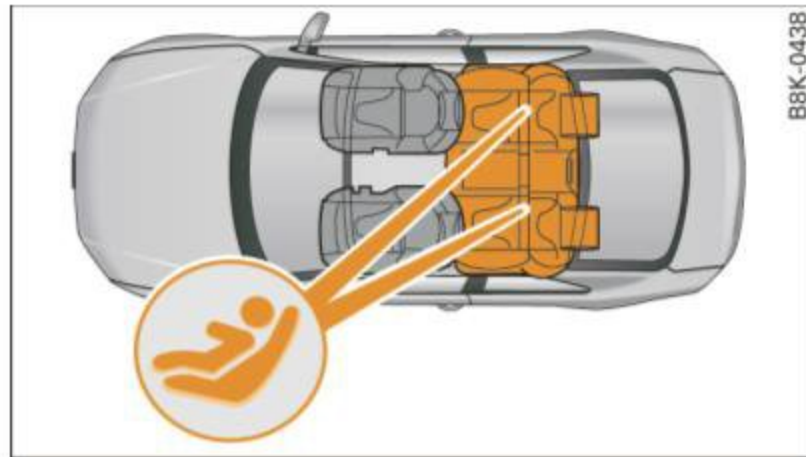


Fig. 187 Schematic overview: LATCH anchorage point locations

The illustration ⇒ fig. 187 shows the seating locations in your vehicle which are equipped with the LATCH-system. ■

Description

The lower anchorage positions are marked for quick locating.



Fig. 188 Rear seats: lower anchorage bracket locations

Lower anchorages

The lower anchorage attachment points are located on the rear end of the rear seatback ⇒ fig. 188.

Lower anchorages secure the child restraint in the seat without using the vehicle's safety belts. Anchorages provide a secure and easy-to-use attachment and minimize the possibility of improper child restraint installation.

All child restraints manufactured after September 1, 2002, must have lower anchorage attachments for the *LATCH* system.

Please remember that the lower anchorage points are only intended for installation and attachment of child restraints specifically certified for use with *LATCH* lower anchorages. Child restraints that are not equipped with the lower anchorage attachments can still be installed in compliance with the child restraint manufacturer's instructions on using vehicle safety belts.

WARNING

Improper installation of child restraints will increase the risk of injury in a crash.

⚠ WARNING (continued)

- Always carefully follow the child restraints manufacturer's instructions for proper installation of the child restraint and proper use of the lower anchorages or safety belts in your vehicle.
- Never secure or attach any luggage or other items to the **LATCH** lower anchorages.
- Always read and heed the important information about child restraints in this chapter and **WARNINGS** ⇒ *page 197, "Child Safety"*. ■

Installing a child restraint using the lower anchorages of the LATCH system

Child safety seats equipped with the LATCH system can quickly and easily be secured to the rear seats.



Fig. 189 LATCH-type seat with both latch bars extended



Fig. 190 Installation of child safety seat with rigid latches on bars

Whenever you install a child restraint always refer to the child restraint manufacturer's instructions.

- Make sure the seat back of the rear seat bench is in the upright position and securely latched in place.
- Insert the latches onto the lower anchorages ⇒ *page 212, fig. 189* or ⇒ *page 212, fig. 190*.
- Make sure you hear the child restraint click securely into place. This indicates that the seat is securely mounted on the anchors.
- Pull on the child restraint once you have mounted it to make sure it is secure.

⚠ WARNING

Improper use of the LATCH system can increase the risk of serious personal injury and death in an accident.

- These anchors were developed solely for child safety seats using the "LATCH" system.
- Never attach other child safety seats, belts or other objects to these anchors.
- Always make sure that you hear a click when latching the seat in place. If you do not hear a click the seat is not secure and could

⚠ WARNING (continued)

fly forward and hit the interior of the vehicle, or be ejected from the vehicle.

⚠ WARNING

Improper installation of child restraints will increase the risk of injury in an accident.

- Always follow the child restraint system manufacturer's instructions for proper installation of the child restraint system and proper use of tether straps as well as the lower anchorages or safety belts in your vehicle.
- Always read and heed the important information and WARNINGS about child safety and the installation of child restraint systems ⇒ page 197, "Child Safety". ■

Mounting and releasing the anchorage hook

If you use a child restraint system with hooks or other latches attached to adjustable straps.

Mounting

- Press the anchorage hook with the spring catch release onto the lower anchorage so that the anchorage hook locks into place.
- Pull on the anchorage hook to make sure that it has securely engaged the lower anchorage.
- Tighten the strap following the child restraint manufacturer's instructions.

Releasing

- Loosen the tension on the strap following the child restraint manufacturer's instructions.

- Depress the spring catch on the hook.
- Hold the spring catch in depressed position.
- Move the hook in the direction of the vehicle floor so that there is enough space to release the anchorage hook from the lower anchorage.

⚠ WARNING

- Improper installation of child restraints will increase the risk of injuries in a crash.
- Always refer to the child restraints manufacturer's instructions for proper installation of the child restraint and proper use of the lower anchorages or safety belts in your vehicle. ■

Tether anchors

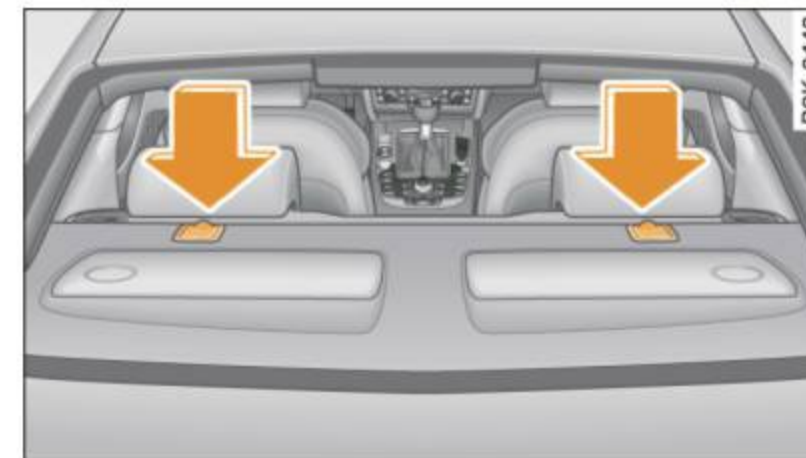


Fig. 191 Tether anchors: recess flaps behind the rear seat-backs

Beginning with model year 2000, the rear seating positions are equipped with two tether anchors.

The tether anchors for the two rear seating positions are located in recesses in the rear window shelf ⇒ fig. 191. ▶

WARNING

Improper installation of child restraints will increase the risk of injury and death in a crash.

- Improper use of child restraint anchors (tether anchors) could lead to injury in a collision. The anchors are designed to withstand only those loads imposed by correctly fitted child restraints.
- Never mount two child restraint systems on one LATCH lower anchor point.
- Never attach two child restraint systems to one tether strap or tether anchorage.
- Always follow the instructions provided by the manufacturer of the child restraint you intend to install in your Audi.
- Never use child restraint tether anchorages to secure safety belts or other kinds of occupant restraints.
- Never attach a tether strap to a tie-down hook in the luggage compartment.
- Never secure or attach any luggage or other items to the LATCH lower anchorages or to the tether anchors. ■

Tether strap

A tether is a straight or V-shaped strap that attaches the top part of a child restraint to special anchorage points in the vehicle.

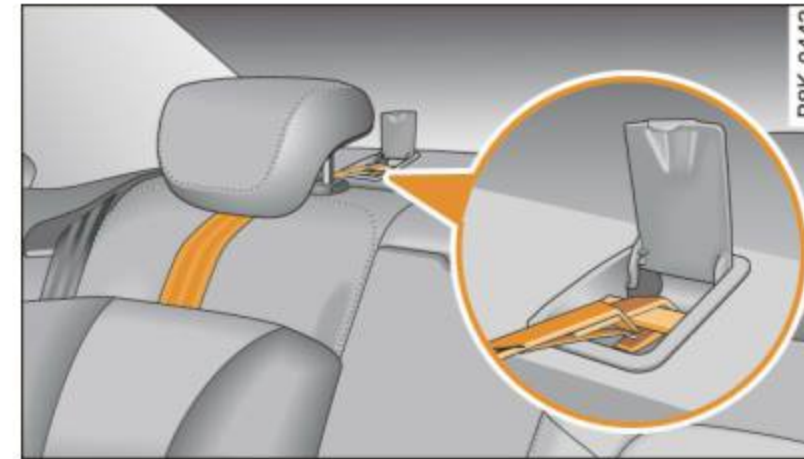


Fig. 192 Tether strap: proper routing and mounting

The purpose of the tether is to reduce the forward movement of the child restraint in a crash, in order to help reduce the risk of head injury that could be caused by striking the vehicle interior.

Forward facing child restraints manufactured after September 1, 1999, are required by U.S. federal regulations to comply with child head movement performance requirements. These new performance requirements make a tether necessary on most new child safety seats.

WARNING

Improper installation of child restraints will increase the risk of injury in a crash.

- Never attach a child safety seat tether strap to a tie-down hook in the luggage compartment.
- Never secure or attach any luggage or other items to the LATCH lower anchorages or to the tether. ■

Using tethers on rearward-facing child restraint systems

Currently, few rearward-facing child restraint systems come with a tether. Please read and heed the child restraint system manufacturer's instructions carefully to determine how to properly install the tether.

WARNING

A child in a rearward-facing child safety seat installed on the front passenger seat will be seriously injured and can be killed if the front airbag inflates - even with an Advanced Airbag System.

- The inflating airbag will hit the child safety seat or infant carrier with great force and will smash the child safety seat and child against the backrest or door.
- A tight tether or other strap on a rearward-facing child restraint attached to the front passenger seat can put too much pressure on the weight-mat in the seat and register a heavier weight in the Advanced Airbag System. The heavier weight registered can make the system work as though an adult were on the seat and deploy the Advanced Airbag when it must be suppressed causing serious or even fatal injury to the child.
- If you must install a rearward facing child safety seat on the front passenger seat because of exceptional circumstances and the PASSENGER AIR BAG OFF light does not come on and stay on, immediately install the rearward-facing child safety seat in a rear seating position and have the airbag system inspected by your authorized Audi dealer. ■

Securing the upper tether strap to the anchor bracket

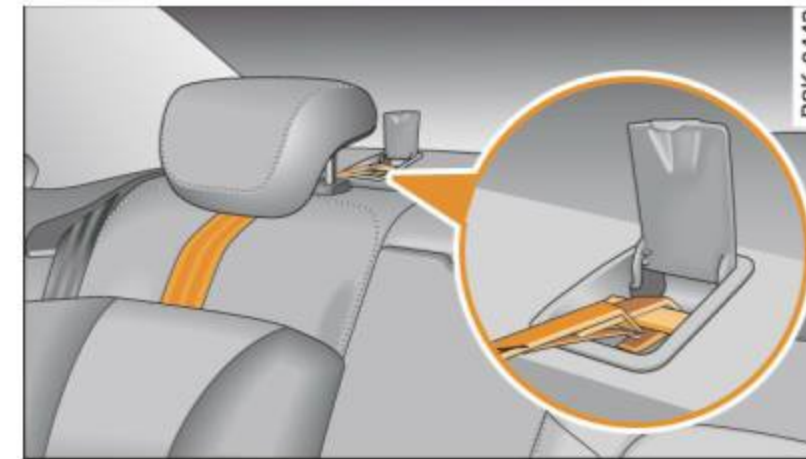


Fig. 193 Tether strap: proper routing and mounting

Securing the child restraint tether strap to the tether anchor

- Release or deploy the tether strap on the child restraint according to the child restraint manufacturer's usage instructions.
- Guide the upper tether strap **under** the rear head restraint ⇒ fig. 193 (raise the head restraint if necessary).
- Slide the tether strap hook over the anchor bracket.
- Pull on the tether strap hook so that the spring catch of the hook engages.
- Tighten the tether strap firmly following the child restraint manufacturer's instructions.

Releasing the tether strap

- Loosen the tension following the child restraint manufacturer's instructions.
- Depress the spring catch on the hook and release it from the tether anchor. ▶

 **WARNING**

Improperly installed child safety seats increase the risk of serious personal injury and death in a collision.

- **Never unfasten the safety belt to deactivate the convertible locking retractor for child restraints while the vehicle is moving. You would not be restrained and could be seriously injured in an accident.**
- **Always read and heed all WARNINGS whenever using a child restrained in a vehicle is being used ⇒ *page 197*. Special precautions apply when installing a child safety seat on the front passenger seat ⇒ *page 174*, “Child restraints on the front seat – some important things to know”.**

 **Note**

If you leave the child restraint with the tether strap firmly installed for several days, this could leave a mark on the upholstery on the seat cushion and backrest in the area where the tether strap was installed. The upholstery would also be permanently stretched around the tether strap. This applies especially to leather seats. ■

Additional Information

What types of child restraint anchors are available and how are they related to child safety?

For years, child restraints have been installed using the safety belts already present in every vehicle.

Since September 1, 1999, child restraint manufacturers have been providing tether straps that attach the top of the child restraint to the vehicle's structure, on most of their forward-facing systems in order to comply with U.S. Federal regulations for child restraint

performance in a crash. Vehicle manufacturers are required to phase-in tether anchorages for attachment of the tether strap in their U.S. vehicles beginning September 1, 1999.

Some child restraint system manufacturers have been providing tether straps on certain models of their child restraint systems, either as standard equipment or as a retrofit, for several years. Check with the manufacturer of the child restraint system for tether strap availability.

To provide a simpler and more practicable way to attach the child restraint system on the vehicle seat, U.S. Federal regulations require the phase-in of lower anchorages in vehicles and devices on new child restraint systems to attach to the vehicle anchorages.

Child restraint system manufacturers will probably offer two kinds of lower anchorages on their child safety seats

They could come with:

- hooks or other latches attached to adjustable straps or
- rigid latches on bars that extend out the back of the child restraint and are released with release buttons at the bottom of the child restraint.

In addition to the LATCH lower anchorages, both of these child restraint systems use tether straps to help keep the child restraint system firmly in place. ■

Where can I get additional information about child restraint application and usage?

There are a number of sources of additional information about child restraint selection, installation and usage:

NHTSA advises that the best child safety seat is the one that fits your child and fits in your vehicle, and that you will use correctly and consistently.

Try before you buy! 

National Highway Traffic Safety Administration

Tel.: (888) DASH-2-DOT
www.nhtsa.dot.gov

National SAFE KIDS Campaign

Tel.: (202) 662-0600
www.safekids.org

Safety BeltSafe U.S.A

Tel.: (800) 745-SAFE (English)
Tel.: (800) 747-SANO (Spanish)
www.carseat.org

Transport Canada

Tel.: (888) 675-6863
www.tc.gc.ca

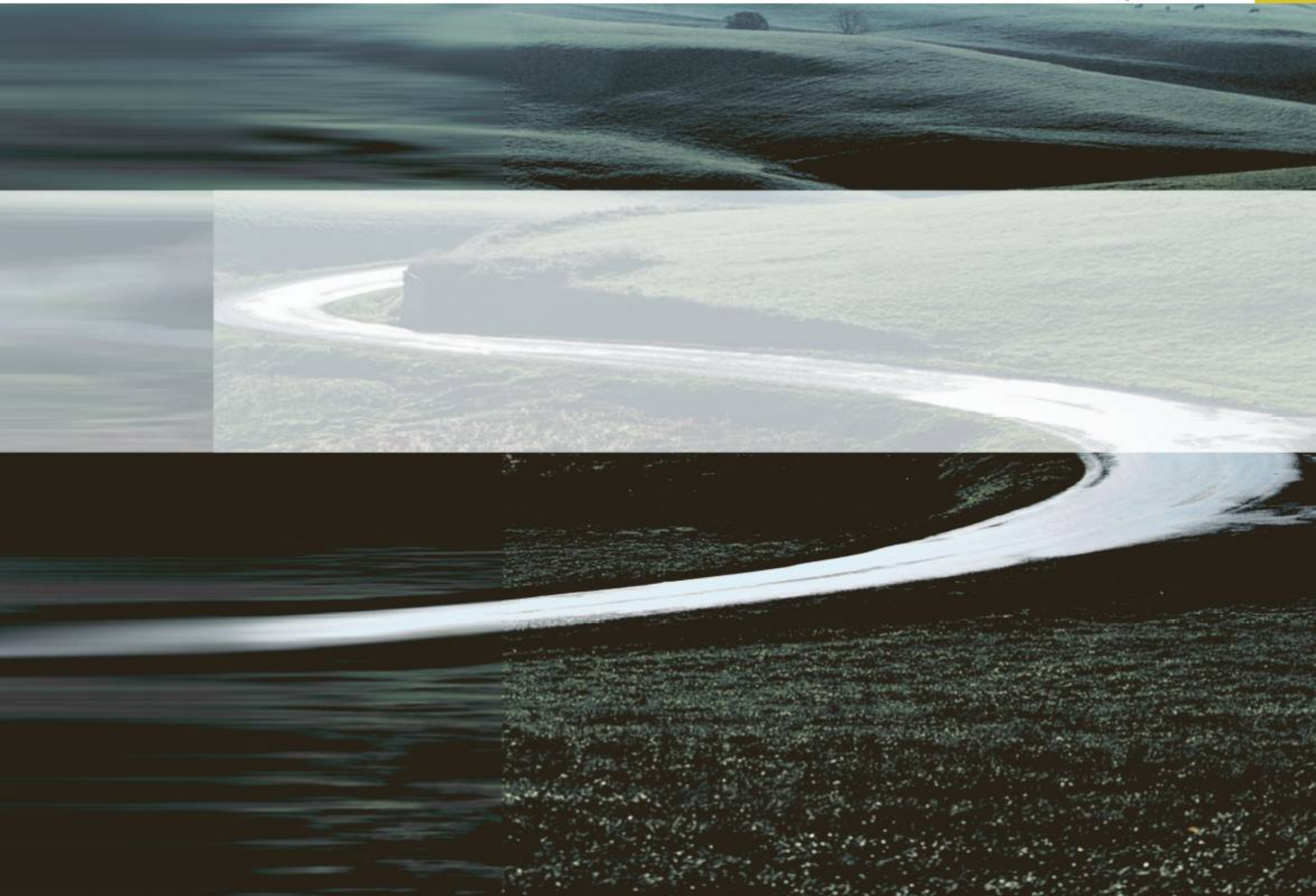
Audi Client Relations

Tel.: (800) 822-2834

Sit Safe® Audi Child Passenger Safety Program

Tel.: 1-800-337-7116
www.programprofessionals.org ■





Intelligent technology

Notice about data recorded by vehicle control modules

Your vehicle is not equipped with an Event Data Recorder (EDR), installed by some manufacturers for the express purpose of capturing data for retrieval after an accident or crash event. EDR's are sometimes called "crash recorders".

Some state laws restrict the retrieval or downloading of data stored by EDR's that were installed in a vehicle for the express purpose of retrieving data after an accident or crash event without the owner's consent.

Although your vehicle is not equipped with an EDR, it is equipped with a number of electronic control modules for various vehicle systems such as, for example, engine function, emission control, as well as for the airbags and safety belts.

These electronic control modules also record vehicle-related data during normal vehicle operation for diagnostic and repair purposes. The recording capacity of the electronic control modules is limited to data (no sound is recorded) and only a small amount of data is actually recorded over a very limited period of time and stored when a system fault or other condition is sensed by a control unit. Some of the data then stored may relate to vehicle speed, direction, braking as well as restraint system use and performance in the event of a crash or other condition. Stored data can only be read and downloaded with special equipment. ■

Electronic Stabilization Program (ESP)

General information

The ESP improves the vehicle stability.



Fig. 194 ESP button



Fig. 195 Center console with ESP switch


ESP is designed to help you maintain vehicle control in situations where the car approaches the limits of "grip", especially when accelerating and cornering. ESP reduces the risk of skidding and improves stability under all road conditions. ►

The system operates across the entire speed range in combination with the ABS system. If the Anti-Lock Brake System (ABS) malfunctions, the ESP will also shut down.

How the system works

The Anti-Lock Brake System (ABS), Electronic Differential Lock (EDL) and the Anti-Slip Regulation System (ASR) are integrated in the electronic stabilization program. In addition to the data provided by these functions, the ESP control unit requires additional measurement data provided by high performance sensors. The rotational speed of the vehicle about its vertical axis, vehicle acceleration in the fore-and-aft and lateral directions, the brake pressure, and the steering angle are all measured.

The direction in which the driver wishes to travel is determined with the aid of the steering angle and vehicle speed and is continually compared with the actual behavior of the vehicle. If the two do not match, for example, when the vehicle starts hydroplaning on a wet road, ESP will automatically brake the appropriate wheel to correct the problem.

The vehicle is then stabilized by the forces acting on the wheel during braking. If the vehicle is *oversteering* (the vehicle turns too sharply and the rear wheels slide toward the outside of a curve), the brakes are mainly applied on the wheel that is on the outside of the curve. In the case of a vehicle that is *understeering* (the vehicle does not turn sharply enough and pushes out of a curve), the brakes are applied as needed on the wheel that is on the inside of the curve or additionally on the other wheels. An acoustic signal indicates when ESP brake application cuts in ⇒ .

The system operates across the entire speed range in combination with the ABS system ⇒ [page 224](#). If the Anti-Lock Brake System (ABS) malfunctions, the ESP will be out of action as well.

Activating

When you turn on the engine, ESP will automatically be activated and will perform a self-test. As soon as the test is completed, the system is in normal operating mode.

You can activate a deactivated ESP or deactivated ESP/ASR if required by pressing the ⇒ [page 220, fig. 195](#) ⇒ [page 220, fig. 194](#) button. When they are activated, the message **ESP/ASR on** appears briefly in the display.

Deactivating

The ESP should normally be activated all the time. If necessary, you can deactivate Anti-Slip Regulation (ASR) or the Electronic Stabilization Program (ESP) by pressing the button ⇒ [page 220, fig. 195](#).

- **Deactivating ASR:** Tap the button. In certain exceptional situations (e.g. driving with tire chains), the Anti-Slip Regulation (ASR) can be deactivated ⇒ [page 222](#). The message **ASR off** appears in the display as well.
- **Deactivating ESP/ASR** Press the button for more than 3 seconds. With the ESP/ASR deactivated, the ESP check light comes on, see ⇒ [page 17](#). The message **ESP switched off** appears in the display as well.



WARNING

The Electronic Stabilization Program is nevertheless subject to the laws of physics. It is particularly important to pay attention to this fact on wet and slippery roads. It is therefore important that you always adapt your driving to the condition of the road and traffic conditions. Do not allow the increased safety provided by the Electronic Stabilization Program system to lull you into accepting additional safety risks. ■

Electronic differential lock (EDL)

The electronic differential lock monitors the rotational speed of the drive wheels.

General notes

The electronic differential lock (EDL) helps the car to start moving, accelerate and climb a gradient on surfaces providing poor or

almost no grip. Without EDL, this would be difficult, if not impossible.

How the system works

The EDL operates automatically. It monitors the rotational speed of wheels with the help of the ABS sensors ⇒ *page 224*. If a noticeable *slip* is detected at the wheels (e.g. on slippery ground *on one side*), the spinning wheels are braked and power is transferred to the other wheels. This is done up to a speed of about 60 mph (100 km/h). Noises from the brake system signal that wheel spin is being controlled.

Driving off

When driving off, always be sure to keep road conditions in mind as you accelerate. If one drive wheel spins because it is on a surface with less grip, apply *plenty of* throttle until the car starts to move.

Overheating of brakes

To prevent the disc brake of the braked wheel from overheating if subjected to excessive loads on this wheel, the EDL cuts out temporarily. The vehicle remains operational and behaves in the same way as a vehicle without EDL.

As soon as the brake has cooled down, EDL switches on again automatically.

WARNING

- **When accelerating on slippery surfaces, such as on ice or snow, always be careful when depressing the accelerator pedal. Even with the EDL working, the drive wheels can spin and reduce your ability to control your car. Risk of crash!**
- **The increased safety afforded by EDL does not mean that you can take safety risks. Always adapt your driving style to the road conditions and traffic situation.**

Tips

If a fault occurs in the ABS, the EDL is also not functioning. This is indicated by the ABS warning light ⇒ *page 19*. ■

Anti-Slip Regulation System (ASR)

The Anti-Slip Regulation System prevents the driven wheels from spinning when the car is accelerating.

General notes

The Anti-Slip Regulation System (ASR) is integrated in the electronic stabilization program (ESP). When the vehicle starts up and accelerates, the wheels are prevented from spinning by adjusting the engine power to match the amount of grip available from the road surface.

How the system works

ASR performs automatically, i.e. without the driver's intervention. With the aid of the ABS sensors ⇒ *page 224*, ASR monitors the speed of the driven wheels. If the wheels start to spin, engine torque is reduced automatically until the tires find enough grip to lock onto the road surface. The system is active across the entire speed range.

The ASR works in conjunction with the ABS. If a malfunction should occur in the ABS, the ASR will also be out of action.

Activating

The ESP is automatically activated when the engine is started and it performs a self-test. You can activate a deactivated ASR if required by pressing the ⇒ *page 220*, fig. 195 button. When it is activated, the message **ESP/ASR on** appears briefly in the display.

Deactivating

You can deactivate the ASR if required by pressing the button (for less than 3 seconds) ⇒ *page 220*, fig. 195. With the ASR deactivated, the ESP check light comes on, see ⇒ *page 17*. The message **ASR off** ►

appears in the display as well. The ASR can be deactivated at any speed.

The ASR should normally be activated all the time. Only in certain exceptional situations when some slip is desirable does it make sense to deactivate the ASR. Examples:

- when driving with tire chains
- when driving in deep snow or on loose ground and
- when rocking the vehicle loose after it has become stuck.

When the abnormal situation is over, you should activate the ASR again.

WARNING

The increased safety afforded by ASR does not mean that you can take safety risks. Always adapt your driving style to the road conditions and traffic situation.

Tips


To ensure that the ASR works properly, all four wheels must be fitted with identical tires. Any differences in rolling radius of the tires can cause the system to reduce engine power when this is not desired. See also ⇒ *page 288, "New tires and replacing tires and wheels"*. ■

Braking

General information

What affects braking efficiency?

Operating conditions and driving habits

The brakes on today's automobiles are still subject to wear, depending largely on operating conditions and driving habits ⇒ . On vehicles which are driven mostly in stop-and-go city traffic or which are driven hard, the brake pads should be checked by your


authorized Audi dealer more often than specified in the **Warranty & Maintenance booklet**.

On steep slopes, you should use the braking effect of the engine. This way, you prevent unnecessary wear on the brake system. If you must use your brakes, do not hold the brakes down continuously. Pump the brakes at intervals.

Moisture or road salt


If you are driving faster than 31 mph (50 km/h) and the windshield wipers are on, the brake pads will briefly touch the brake discs in regular intervals so as to improve reaction time when braking on wet surfaces. You, the driver, will not notice anything.

Under certain conditions, for example, when driving through water or very heavy rain, or even after washing your vehicle, the braking effect can be reduced due to moisture (or in freezing conditions ice) on the brake pads. A few careful brake applications should dry off the brake pads or remove any ice coatings.


The effectiveness of the brakes can be reduced when the vehicle is driven on a salt-covered road and the brakes are not used. Here too, you should clean off accumulated salt coating from brake discs and pads with a few careful applications of the brake ⇒ .

Corrosion

There may be a tendency for dirt to build up on the brake pads and corrosion to form on the discs if the car is not driven regularly or only for short trips with little use of the brakes.

If the brakes are not used frequently, or if corrosion has formed on the discs, it is advisable to clean off the pads and discs by braking firmly a few times from a moderately high speed ⇒ .

Faults in the brake system

If you should notice a *sudden* increase in brake pedal travel, then one of the two brake circuits may have failed ⇒ . ▶

Low brake fluid level


Malfunctions can occur in the brake system if the brake fluid level is too low. The brake fluid level is monitored electronically.

WARNING

- You should perform braking maneuvers for the purpose of cleaning the brake system only if road conditions permit. Other road users must not be put at risk - you may cause an accident!
- Before descending a steep grade, reduce speed and shift transmission into a lower gear or lower driving range. Do not ride the brakes or hold the pedal down too long or too often. This could cause the brakes to get hot and diminish braking efficiency.
- Do not "ride the brakes" by resting your foot on the pedal when you do not intend to brake. This may cause the brakes to overheat, premature wear and increased stopping distance.
- Under certain climatic and operating conditions such as passing through water, driving in heavy rain or after washing the vehicle, the effectiveness of the brakes can be reduced. In winter, ice can accumulate on the brake pads, linings, discs and drums. Carefully apply brakes for a test. Brakes will dry and ice coatings will be cleaned off after a few careful brake applications.
- Driving for an extended period of time on salt-covered roads without using your brakes can also affect braking efficiency. Clean off accumulated salt coating from brake discs and pads with a few careful brake applications.
- If you damage the front spoiler, or if you install a different spoiler, be sure the air flow to the front brakes is not obstructed. Otherwise the brake system could overheat reducing the effectiveness of the entire brake system.
- Failure of one brake circuit will impair the braking capability resulting in an increased stopping distance. Avoid driving the vehicle and have it towed to the nearest authorized Audi dealer or qualified workshop. ■

Brake booster

The brake booster adds extra braking power.

The brake booster works with vacuum pressure which is created only when the engine is running ⇒ .

WARNING

- Never let the vehicle roll to a stop with the engine shut off.
- If the brake booster is not working, for example when towing your vehicle, or because the brake booster has somehow been damaged, the brake pedal must be pressed considerably harder to make up for the lack of booster assistance. ■

Functioning of Anti-Lock Brake System (ABS)

ABS prevents the wheels from locking up under braking.

The ABS contributes effectively to vehicle control since it prevents the wheels from *locking* when the brakes are applied. This means that the vehicle remains steerable and is less likely to skid.

With ABS you do not need to pump the brake. Just hold the brake pedal down.

However, do not expect the ABS to shorten braking distance under *all* circumstances. When driving on gravel or on newly fallen snow on top of icy surfaces, braking distance may be even longer, therefore, under these circumstances, it is especially important that you drive slowly and with great care.

How the ABS system works

An automatic check is made when a speed of about 12 mph (20 km/h) is reached. When this happens, a pumping noise can be heard. ▶

If an individual wheel begins to rotate too slowly in relation to vehicle speed and tends to lock, the ABS automatically reduces brake pressure to prevent that wheel from locking.

This automatic adjustment process will cause a **slight vibration** of the brake pedal and some noises to alert you that vehicle speed must be adapted to existing road and traffic conditions.

WARNING

Although the ABS is very effective, always remember that braking capability is limited by tire traction. Always adjust your driving speed according to the road and traffic conditions. Do not let the extra safety afforded by the ABS tempt you into taking extra risks. The ABS cannot overcome the laws of physics.

Tips

- If ABS is not functioning properly, a warning light will come on. See ⇒ page 19.
- If a fault occurs in the ABS, the EDL is also not functioning. This is indicated by the ABS warning light. ■

Brake assist

Brake assist is designed to achieve the optimum braking effect.

Brake assist helps to increase the *effective* braking power and thus to achieve a shorter stopping distance. If the driver presses the brake pedal very quickly, brake assist automatically boosts the braking force to the maximum level, up to the point where the anti-lock brake function (ABS) intervenes to stop the wheels from locking. You should then keep the brake pedal pressed until the vehicle has braked to the required speed. Brake assist switches itself off as soon as you release the brake pedal.

WARNING

Please remember that the accident risk always increases if you drive too fast, especially in corners or on a slippery road, or if you follow the vehicle ahead of you too closely. Increased risk of an accident cannot be compensated for even by brake assist, so always maintain a safe speed. ■

Servotronic® - advanced power steering system

The power steering systems uses the power of the running engine to allow precise steering with little effort.

The advanced *Servotronic*® power steering system senses the road speed and electronically adjusts power assistance to provide comfortable and safe steering response exactly matched to the vehicle speed.

Power steering will not work if the engine is off. As a result, the steering wheel will be hard to turn.

The power steering fluid level is checked during the scheduled maintenance services.

Note

If there is an electronic malfunction, *servotronic* will still function like a conventional power steering system, providing a constant steering support force that is no longer proportionate to the vehicle speed. This is most noticeable when turning the steering wheel at low speeds (for example when parking), - more effort will be required than usual.

- Be aware of the different than usual steering response and adjust your steering force accordingly.
- Have the problem checked and set right by an Audi dealer as soon as possible.

 **Tips**

- When the engine is running, never hold the steering wheel turned all the way to the right or to the left for longer than 15 seconds. The power steering pump will overheat the hydraulic fluid if you keep holding the steering wheel turned all the way. This is likely to damage the power steering system.
- If the power steering system should fail entirely, or if the engine is not running (for example, while being towed), you will still be able to steer the vehicle. However, *considerably* more effort will be required to do so.
- If the power steering system should have a leak, or is not functioning properly, contact your authorized Audi dealer immediately.
- The power steering system requires a specially formulated hydraulic fluid. The power steering reservoir is the one located farthest to the rear on the left side of the engine compartment ⇒ *page 260*. The correct fluid level in the reservoir is important for proper functioning of the power steering. ■

Driving with your quattro®

With all wheel drive, all four wheels are driven.

General information

With all wheel drive, power is distributed to all four wheels. This happens automatically depending on your driving style and the road conditions at the time. See also ⇒ *page 221*, "Electronic differential lock (EDL)".

Winter tires

When driving in the winter, your vehicle with all wheel drive has an advantage, even with regular tires. In winter road conditions it may be advisable to mount winter tires (or all-season tires) for improved driveability and braking: these tires must be mounted on **all four wheels**. See also ⇒ *page 292*, "Winter tires".

Tire chains

Where tire chains are mandatory on certain roads, this normally also applies to vehicles with all wheel drive ⇒ *page 293*, "Snow chains".

Replacing wheels/tires

Vehicles with all wheel drive must always have tires of the same size. Also avoid tires with different tread depths. For details see *page 288*, "New tires and replacing tires and wheels".

Off-Road driving?

Your Audi does not have enough ground clearance to be used as an off-road vehicle. It is therefore best to avoid rough tracks and uneven terrain as much as possible. Also refer to ⇒ *page 231*.

 **WARNING**

Always adjust your driving to road and traffic conditions. Do not let the extra safety afforded by all wheel drive tempt you into taking extra risks.

- Although the all wheel drive is very effective, always remember that braking capacity is limited by tire traction. You should therefore not drive at excessive speeds on icy or slippery road surfaces.
- On wet road surfaces, be careful not to drive too fast because the front wheels could begin to slide on top of the water (aquaplaning). If this should occur, you will have no warning from a sudden increase in engine speed as with a front-wheel drive vehicle. Always drive at speeds which are suited to the road conditions – risk of crash. ■

Energy management

Starting ability is optimized

Energy management controls the distribution of electrical energy and thus optimizes the availability of electrical energy for starting the engine.

If a vehicle with a conventional energy system is not driven for a long period of time, the battery is discharged by idling current consumers (e.g. immobilizer). In certain circumstances it can result in there being insufficient energy available to start the engine.

Intelligent energy management in your vehicle handles the distribution of electrical energy. Starting ability is markedly improved and the life of the battery is extended.

Basically, energy management consists of **battery diagnosis**, **idling current management** and **dynamic energy management**.

Battery diagnosis

Battery diagnosis continuously determines the state of the battery. Sensors determine battery voltage, battery current and battery temperature. This determines the current state of charge and the power of the battery.

Idling current management

Idling current management reduces energy consumption while the vehicle is standing. With the ignition switched off, it controls the energy supply to the various electrical components. Data from battery diagnosis is considered.

Depending on the battery's state of charge, individual consumers are gradually turned off to prevent excessive discharge of the battery and thus maintain starting capability.

Dynamic energy management

While the vehicle is being driven, dynamic energy management distributes the energy generated according to the needs of the indi-

vidual components. It regulates consumption, so that more electrical energy is not being used than is being generated and ensures an optimal state of charge for the battery.



Tips

- But even energy management cannot negate the limits of physics. Consider that the power and life of a battery are limited.
- If starting ability is threatened, you are informed by a warning ⇒ *page 228*, "Driver notification in the instrument cluster display". ■

What you should know

The highest priority is given to maintaining starting capability.

The battery is severely taxed in short-distance driving, in city traffic and during the cold time of year. Abundant electrical energy is required, but only a little is generated. It is also critical if the engine is not running and electrical components are turned on. In this instance energy is being consumed but none is being generated.

It is in precisely these situations that you will notice energy management actively regulating the distribution of energy.

Vehicle stands for an extended period

If you do not drive your vehicle over a period of several days or weeks, electrical components are gradually cut back or switched off. This reduces energy consumption and maintains starting capability over a longer period.

Take into consideration that when you unlock your vehicle, some convenience functions, such as the remote key or power seat adjustment, may not be available. The convenience functions will be available again when you turn on the ignition and start the engine. ►

With the engine turned off

If you listen to the radio, for example, with the engine turned off or use other MMI functions, the battery is being discharged.

If starting capability is jeopardized due to energy consumption, the following warning appears in the MMI display:

Please start engine, otherwise system will switch off in 3 minutes.

The warning indicates that the system will be turned off automatically after 3 minutes. If you wish to continue using the functions, you have to start the engine.

With the engine running

Although electrical energy is generated when the vehicle is being driven, the battery can become discharged. This happens mostly when little energy is being generated and a great deal consumed and the battery's state of charge is not optimal.

To bring the energy balance back into equilibrium, consumers which require especially large amounts of energy are temporarily cut back or switched off. Heating systems in particular require a great deal of energy. If you notice, for example, that the heated seats* or the heated rear window are not heating, they have been temporarily cut back or switched off. These systems will be available again as soon as the energy balance has been restored.

You will also notice that engine idle speed has been increased slightly. This is normal and not a cause for concern. By increasing engine idle speed the additional energy required is generated and the battery is charged. ■

Driver notification in the instrument cluster display

If battery power drops into the range where it can limit the ability of the engine to start, this is shown in the instrument cluster display with the following driver message:

 **Low battery charge: battery will be charged while driving**

This notification reminds you that the starting capability of the engine may be limited. As soon as you start driving again, the battery will be recharged and the notification will go out.

Driver notification appears and goes out again

If this driver notification appears after the ignition is turned on or while driving and it goes out again after a while, the battery has been adequately recharged.

Driver notification appears and does not go out again

If this driver notification appears after the ignition is turned on or while driving and does not go out again, the battery's state of charge is not in the optimal range. Starting ability is restricted. Have the battery checked as soon as possible by an authorized Audi dealer or qualified workshop. ■

Driving and environment

The first 1,000 miles (1,500 km) and afterwards

New engine

The engine needs to be broken-in during the first 1,000 miles (1,500 km).

For the first 600 miles (1,000 kilometers):

- Do not use full throttle.
- Do not drive faster than 3/4 of the top speed marked on the speedometer.
- Avoid high engine speeds.

From 600 to 1,000 miles (1,000 to 1,500 kilometers):

- Speeds can *gradually* be increased to the maximum permissible road or engine speed.

During and after break-in period

- Do not rev the engine up to high speeds when it is cold. This applies whether the transmission is in N (Neutral) or in gear.

After the break-in period

- Do not exceed maximum engine speed under any circumstances.
- Upshift into the next higher gear *before* reaching the red area at the end of the tachometer scale ⇒ *page 12*.

During the first few hours of driving, the engine's internal friction is higher than later when all the moving parts have been broken in. How well this break-in process is done depends to a considerable extent on the way the vehicle is driven during the first 1,000 miles (1,500 kilometers).



Note

Extremely high engine speeds are automatically reduced. However, these rpm limits are programmed for an engine well broken-in, not a new engine.



For the sake of the environment

Do not drive with unnecessarily high engine speeds - upshifting early saves fuel, reduces noise and protects the environment. ■

New tires

If your vehicle is running on new tires, drive very carefully for the first 350 miles (500 kilometers) after fitting.




WARNING

New tires tend to be slippery and must also be "broken-in". Be sure to remember this during the first 350 miles (500 kilometers). Brake gently. Avoid following closely behind other vehicles or other situations that might require sudden, hard braking. ■

New brake pads

Remember that new brake pads do not have a full braking effect during the first 250 miles (400 kilometers) after they are installed.

New brake pads have to be “burnished in” before they have optimal grab ⇒ .


During the break-in period, you should avoid putting severe loads on the brakes. Severe loads include, for example, sudden hard braking, in particular at very high speeds or, for example, on mountain passes.

WARNING

New brake pads don't have the best stopping power and must be “broken-in” during the initial 100 to 150 miles (150 to 200 kilometers) of normal city driving. You can compensate for this by pressing the brake pedal more firmly. This also applies later when new pads are installed. ■

Catalytic converter

It is very important that your emission control system (catalytic converter) is functioning properly to ensure that your vehicle is running in an environmentally sound manner.

- Always use lead-free gasoline ⇒ *page 253, “Fuel supply”*.
- Never run the tank down all the way to empty.
- Never put too much motor oil in your engine ⇒ *page 264, “Adding engine oil 

The catalytic converter is an efficient “clean-up” device built into the exhaust system of the vehicle. The catalytic converter burns many of the pollutants in the exhaust gas before they are released into the atmosphere.*

The exclusive use of unleaded fuel is critically important for the life of the catalytic converter and proper functioning of the engine.

WARNING

- Do not park or operate the vehicle in areas where the hot exhaust system may come in contact with dry grass, brush, fuel spill or other material which can cause a fire.
- Do not apply additional undercoating or rustproofing on or near the exhaust manifold, exhaust pipes, catalytic converter or heat shields. During driving, the substance used for undercoating could overheat and cause a fire.

Note

- Be aware that just one tank filling with **leaded** fuel will already seriously degrade the performance of the catalytic converter.
- Do not exceed the correct engine oil level ⇒ *page 264*.
- Do not drive until the fuel tank becomes completely empty. The engine could misfire. Unburned fuel could also get into the exhaust system and this could cause the catalytic converter to overheat.
- Do not turn off the ignition while the vehicle is moving.
- Do not continue to operate your vehicle under these conditions, as otherwise fuel can reach the catalytic converter. This could result in overheating of the converter, requiring its replacement.
- To assure efficient operation of the Emission Control System:
 - Have your vehicle maintained properly and in accordance with the service recommendations in your Warranty & Maintenance booklet.

- Lack of proper maintenance as well as improper use of the vehicle will impair the function of the emission control system and could lead to damage.



For the sake of the environment

Even when the Emission Control System is operating properly, the exhaust gas can have a sulfur-like exhaust gas smell under some operating states. This depends on the sulfur content of the fuel being used. Using a different brand of fuel may help, or filling the tank with lead-free super grade gasoline. ■

Avoid damaging the vehicle

When you are driving on poor roads, or over curbs, steep ramps, etc., make certain that low-lying parts such as spoilers and exhaust system parts do not bottom out and get damaged.

This is especially true for vehicles with low-slung chassis (sports chassis)* and fully loaded vehicles. ■

Operate your vehicle economically and minimize pollution

General

Your personal style of driving will determine the economy of your vehicle, as well as exhaust and noise levels.

Fuel economy, environmental impact, and wear on your engine, brakes and tires largely depend on three factors:

- your personal driving style
- operating conditions
- technical limitations

If you anticipate what you need to do next and drive economically, you can easily cut your fuel consumption by 10-15 percent. This section will give you some tips on how you can help the environment and your pocketbook.



Tips

The consumption estimates as published by ENVIRONMENTAL PROTECTION AGENCY (EPA) and Transport Canada may not correspond to your actual consumption on the road, which will vary depending upon vehicle load and speed, road and weather conditions, trip length, etc. ■

Drive smoothly and keep a lookout ahead

Vehicles use the most fuel when they are accelerating.

- Avoid unnecessary accelerating and braking.

Vehicles use the most fuel when they are accelerating. If you anticipate what is going to happen next, you will need to brake less and, thus, accelerate less. Let the vehicle coast whenever possible - for example when you see that the next traffic light is red. ■

Avoid full throttle

Driving at moderate speeds saves fuel and improves your mileage.

- Try and keep well below your car's maximum speed.

Accelerating gently reduces fuel consumption, engine wear, and does not disturb the environment.

Fuel consumption, exhaust emissions and engine noise increase disproportionately at high speeds. If you drive at approximately three quarters of top speed, fuel consumption will be reduced by ►

one half. Never drive faster than the posted speed limit and weather conditions permit. ■

Reducing unnecessary idling

Even when your car is just idling it burns up fuel.

- Shut the engine off when you are not driving the vehicle.
- Do not warm up the vehicle by letting the engine run at idle.

It makes sense to shut off the engine in traffic jams, when waiting for trains to pass at railroad crossings, or at traffic lights that have long waits on red. Turning the engine off for just 30-40 seconds saves more fuel than is burned starting the engine again.

It takes a long time for the engine to warm up fully when it is running at idle. However, wear and noxious emissions are especially high when the engine is warming up. So you should drive away as soon as you start the engine and avoid running at high rpms while the engine is still warming up.

Note

Do not leave engine idling unattended after starting. If warning lights should come on to indicate improper operation, they would go unheeded. Extended idling also produces heat, which could result in overheating or other damage to the vehicle or other property. ■

Regular maintenance

A badly tuned engine unnecessarily wastes a lot of fuel.

- Have your vehicle serviced at regular intervals.

By having your vehicle regularly serviced by an authorized Audi dealer helps to ensure that it runs properly and economically. The condition of your vehicle not only affects its safety and ability to hold its value, it also affects **fuel consumption**.

Check your oil each time you fill your tank.

The amount of oil used is related to engine load and speed.

It is normal for the oil consumption of a new engine to reach its lowest value after a certain mileage has been driven.

You must drive your vehicle about 3,000 miles (5,000 kilometers) before you can properly assess oil consumption.

This also applies to fuel consumption and engine output.

Note

- Have your vehicle maintained properly and in accordance with the service recommendations in your Warranty & Maintenance booklet. Lack of proper maintenance as well as improper use of the vehicle will impair the function of the emission control system and could lead to damage.
- Do not alter or remove any component of the Emission Control System unless approved by the manufacturer.
- Do not alter or remove any device, such as heat shields, switches, ignition wires, valves, which are designed to protect your vehicle's Emission Control System and other important vehicle components. ■

Fewer short trips

Fuel consumption will always be relatively high on short trips.

- Try to avoid driving short distances with a cold engine. ►

The engine and catalytic converter have to reach their optimal **operating temperature** to reduce fuel consumption and noxious emissions effectively.

Just after starting, a cold engine in a mid-size car only achieves a fuel economy of 6-8 miles per gallon (30-40 l/100km). After about a half a mile, fuel economy climbs to 12 mpg (20 l/100 km). After about 2.5 miles (4 km), the engine is at its proper operating temperature and fuel economy has reached a normal level. So you can see that you should avoid short trips whenever possible.

The **outside temperature** is also critical in this regard. Your car consumes more fuel in the winter than in the summer. ■

Trailer towing

Driving with a trailer

General information

Your Audi was designed primarily for passenger transportation.

If you plan to tow a trailer, please remember that the additional load will affect durability, economy and performance.

Trailer towing not only places more stress on the vehicle, it also calls for more concentration from the driver.

For this reason, always follow the operating and driving instructions provided and use common sense. ■


Technical requirements

Trailer hitch

Use a weight-carrying hitch conforming to the gross trailer weight. The hitch must be suitable for your vehicle and trailer and must be mounted securely on the vehicle's chassis at a *technically sound* location. Use only a trailer hitch with a removable ball mount. Always check with the trailer hitch manufacturer to make sure that you are using the correct hitch.


Do not use a bumper hitch.

The hitch must be installed in such a way that it does not interfere with the impact-absorbing bumper system. No modifications should be made to the vehicle exhaust and brake systems. From time to time, check that all hitch mounting bolts remain securely fastened.

When you are not towing a trailer, remove the trailer hitch ball mount. This prevents the hitch from causing damage should your vehicle be struck from behind ⇒ .

Trailer brakes

If your trailer is equipped with a braking system, check to be sure that it conforms to all regulations.

The trailer hydraulic brake system must not be directly connected to the vehicle's hydraulic brake system ⇒ .

Safety chains

Always use safety chains between your vehicle and the trailer.

Trailer lights

Trailer lights must meet all regulations. Be sure to check with your authorized Audi dealer for correct wiring, switches, and relays.

Mirrors


If you are unable to see the traffic behind you using the regular outside mirrors, then you *must* install extended mirrors. It is important that you *always* have clear vision to the rear.

WARNING

- **If a trailer has electrical brakes please note that these brakes are not activated by the factory-fitted control unit - risk of accident!**
- **After removing the trailer hitch, do not store it in your vehicle. In case of sudden braking, the hitch could fly forward and injure you or your passengers. ■**

Operating instructions

Maximum trailer weight

A trailer for your vehicle is limited to a typical class 1 or class 2 trailer. 

Trailer load distribution

Be sure the load in the trailer is held securely in place to prevent it from shifting forward, backward or sideways.

Never allow a passenger to ride in a trailer ⇒ ⚠ in "Driving instructions" on page 235.

Engine cooling system

Towing a trailer makes the engine work harder. It is important that the cooling system's performance is up to the additional load. Make sure that the cooling system has enough fluid.

Tire pressure

When towing a trailer, inflate the tires of your vehicle to the cold tire pressure listed under "Full load" on the label located either on the driver's side B-pillar (visible when the door is open) or inside the fuel filler flap. Inflate trailer tires to trailer and tire manufacturers' specifications.

Lights

The headlight settings should be checked with the trailer attached before driving off. Check to make sure both vehicle and trailer lights are working properly.

Safety chains

Be sure trailer safety chains are properly connected from the trailer to the hitch on the vehicle. Leave enough slack in the chains to permit turning corners. When you install safety chains, make sure they will not drag on the road when you are driving.

The chains should cross under the trailer tongue to prevent it from dropping in case of separation from the hitch. ■

Driving instructions

Driving with a trailer always requires extra care and consideration.

To obtain the best possible handling of vehicle and trailer, please note the following:

- Do not tow a loaded trailer when your car itself is not loaded.
- Be especially careful when passing other vehicles.
- Observe speed limits.
- Do not drive at the maximum permissible speed.
- Always apply brakes early.
- Monitor the temperature gauge.

Weight distribution

Towing a loaded trailer with an empty car results in a highly unstable distribution of weight. If this cannot be avoided, drive at very low speeds only to avoid the risk of losing steering control.

A "balanced" rig is easier to operate and control. This means that the tow vehicle should be loaded to the extent possible and permissible, while keeping the trailer as light as possible under the circumstances. Whenever possible, transfer some cargo to the luggage compartment of the tow vehicle while observing tongue load requirements and vehicle loading considerations.

Speed

The higher the speed, the more difficult it becomes for the driver to control the rig. Do not drive at the maximum permissible speed. Reduce your speed even more if load, weather or wind conditions are unfavorable - particularly when going downhill.


Reduce vehicle speed **immediately** if the trailer shows the slightest sign of swaying. **Do not try to stop the swaying by accelerating.** ►

Observe speed limits. In some areas, speeds for vehicles towing trailers are lower than for regular vehicles.

Always apply brakes early. When driving downhill, shift into a lower gear to use the engine braking effect to slow the vehicle. Use of the brakes alone can cause them to overheat and fail.

Coolant temperature

The coolant temperature gauge ⇒ *page 12* must be observed carefully. If the needle moves close to the upper end of the scale, reduce speed immediately and/or turn off the air conditioner.

If the coolant temperature warning light in the instrument cluster starts flashing , pull off the road, stop and let the engine *idle* for about two minutes to prevent heat build-up.

WARNING

Anyone not properly restrained in a moving vehicle is at a much greater risk in an accident. Never let anyone ride in your car who is not properly wearing the restraints provided by Audi. ■

Trailer towing tips

Important to know

Your vehicle handles differently when towing a trailer because of the additional weight and different weight distribution. Safety, performance and economy will greatly depend on how carefully you load your trailer and operate your rig.

Before you actually tow your trailer, practice turning, stopping and backing up in an area away from traffic. Keep practicing until you have become completely familiar with the way your vehicle-trailer combination behaves and responds.

Backing up is difficult and requires practice. Backing up with a trailer generally requires steering action opposite to that when backing up your vehicle without a trailer.

Maintain a greater distance between your vehicle and the one in front of you. You will need more room to stop. To compensate for the trailer, you will need a larger than normal turning radius.

When passing, remember that you cannot accelerate as fast as you normally would because of the added load. Make sure you have enough room to pass. After passing, allow plenty of room for your trailer before changing lanes again.

Avoid jerky starts, sharp turns or rapid lane changes.

Tips

- Do not tow a trailer during the break-in period of your vehicle.
- If you tow a trailer, your Audi may require more frequent maintenance due to the extra load ⇒ *page 330*. ■

Parking on a slope

Do not park on a slope with a trailer. If it cannot be avoided, do so only after doing the following:

When parking:

- Apply the foot brake.
- Have someone place chocks under both the vehicle and the trailer wheels.
- With chocks in place, slowly release the brakes until the wheel chocks absorb the load.
- Turn the wheels towards the curb.
- Apply the parking brake.

- Place an automatic transmission in **P**, respectively a manual transmission in first or reverse gear.

When restarting after parking:

- Apply the foot brake.
- Start the engine.
- Move the selector lever to **D**, respectively a manual transmission in first gear.
- Release the parking brake and slowly pull out and away from the wheel chocks.
- Stop and have someone retrieve the wheel chocks.

Tips

If you move the selector lever of the automatic transmission to **P** before applying the parking brake and before blocking the wheels, you may have to use more force later to move the lever out of the **P** position. ■



Cleaning and protection

General information

Regular care preserves vehicle value.

Any automobile is exposed to industrial fumes, corrosive road salt, muddy dog feet, etc. A well cared for Audi can look like new many years after purchase. Regular and correct care will contribute to maintaining the beauty and value of your Audi.

Furthermore, good care may be a condition for substantiating a warranty claim should corrosion damage or paint defects occur.

Your authorized Audi dealer has a variety of **dedicated vehicle-care products** and can advise which ones to use for cleaning the exterior and interior of your vehicle.

Whether you use products recommended by Audi or other commercially available cleaning agents, please make sure you apply them correctly.

WARNING

- **Cleaning agents may be poisonous. Keep them out of the reach of children.**
- **Heed all caution labels.**
- **Always read directions on the container before using any product. Follow the directions carefully.**
- **Most chemical cleaners are concentrated and have to be diluted.**
- **Use spot removing fluids only in well ventilated areas.**
- **Do not use gasoline, kerosene, diesel fuel, nail polish remover or other volatile fluids. They may be toxic, flammable or hazardous in other ways. Do not wash, wax or dry the vehicle with the ignition on or the engine running.**

WARNING (continued)

- **Do not clean the undersides of chassis, fenders, wheel covers, etc. without protecting your hands and arms. You may cut yourself on sharp-edged metal parts.**
- **Moisture and ice on brakes may impair braking efficiency** ⇒ *page 223, "General information"*. **Test the brakes carefully each time you wash the vehicle.**



For the sake of the environment

Select only environmentally friendly cleaning products. Leftover cleaning products should not be disposed of in the household waste. ■

Care of exterior

Washing

Frequent washing protects the vehicle.

The best protection against environmental influences is *frequent* washing and waxing. How often this is required depends on:

- How much the vehicle is used
- Where the vehicle is parked (garage, in the open under trees, etc.)
- The seasonal and weather conditions
- Environmental influences

The longer bird droppings, insects, tree resin, road and industrial grime, tar, soot, road salt and other materials remain on the vehicle body, the more lasting their destructive effects will be. High temperatures caused by exposure to intense sunlight intensify the corrosive effect, particularly when humidity is high as well. ►

Under certain circumstances, **weekly** washing may be necessary. Under other conditions, a monthly washing and waxing may be adequate.

After the winter, the **underside** of the vehicle should be thoroughly washed, preferably in a professional car wash.

WARNING

Always read and heed all WARNINGS and other information
⇒ **page 240.** ■

Automatic car wash

The vehicle can be washed in almost any modern automatic car wash.

The vehicle paint is so durable that the vehicle can normally be washed without problems in an automatic car wash. However, the effect on the paint depends to a large extent on the design of the facility, the filtering of the wash water, the type of wash and care material, etc. If the paint has a dull appearance after going through the car wash or is scratched, bring this to the attention of the operator immediately. If necessary, use a different car wash.

Before going through a car wash, be sure to take the usual precautions such as closing the windows and the panorama roof. Factory installed antennas must not be removed.


If you have installed additional accessories on the vehicle - such as spoilers, roof rack, etc. - it is best to ask the car wash operator if these should be removed.

WARNING

Always read and heed all WARNINGS and other information
⇒ **page 240.** ■

Washing the vehicle by hand

A lot of water is needed when washing a vehicle by hand.

- Before you start washing, make sure you have read and understood the WARNINGS ⇒  in "General information" on *page 240*.
- First soak all dried dirt until it is soft, then rinse it off.
- As you clean your vehicle, start with the roof and work your way down to the bottom, using a sponge, a sponge glove or a clean brush.
- Rinse the sponge or the sponge glove often, flushing it clean each time.
- Use special car shampoo only for very persistent dirt.
- Rinse the car thoroughly with water.
- Use a chamois leather to gently wipe the exterior dry.

Use a separate sponge for cleaning the wheels, door sills and other regions exposed to road dirt. In this way, you will not scratch the paint with coarse particles imbedded in the sponge the next time you wash the car.

WARNING

- **Do not clean the underside of the chassis, fenders, wheel covers, or other hard to reach parts without protecting your hands and arms. You may cut yourself on sharp-edged metal parts.**
- **Always read and heed all WARNINGS and other information**
⇒ **page 240.**

 **Note**


- Never try to remove dirt, mud or dust if the surface of the vehicle is dry. Never use a dry cloth or sponge, since this could scratch your vehicle's paint or windows.
- Never wash your car in bright sunlight. Drops of water act as magnifying lenses and may damage your paint.
- When you wash your car in the winter: if you rinse your vehicle with a hose, be careful not to aim the stream of water directly at locks, or at door or hatch openings - they can freeze shut.
- Never use sponges designed to remove insects, or any kitchen scouring sponges or similar products. They can damage your paint finish.
- Never use a dry cloth or sponge to clean the headlights. Only use wet cloths or sponges to prevent scratches. It is best to use soapy water.


For the sake of the environment

In the interest of the environment, the vehicle should only be washed in special wash bays. ■

Washing your vehicle with a power washer

Cleaning the exterior of your car with a high-pressure power washer is safe as long as you observe a few simple rules.

- Before using the power washer, make sure you have read and understood the WARNINGS ⇒  in “General information” on page 240.
- Always follow the operating instructions for the power washer.

- Make sure that the jet on the spray hose produces a “fan shaped spray”.
- Do *not* hold the spray nozzle *too close* to soft materials.

When cleaning the vehicle with a power washer *always* follow the operating instructions. This applies particularly to the **operating pressure** and the **spraying distance**. Maintain a sufficient distance to soft materials such as rubber hoses and sound/vibration deadening materials (particularly on the underside of the engine hood). Do not use a jet which sprays water in a **direct stream** or one that has a **rotating** jet.

Water temperature should not exceed 140 °F (60 °C).


WARNING

Never wash tires with a jet that sprays water in a direct stream. This could cause invisible damage to the tires and weaken them, even if the spray is from a relatively long distance and for a short time. Damaged and weakened tires can fail and cause accidents and personal injury.


Note

To avoid damaging your vehicle, always make sure that there is sufficient distance between the spray head and soft materials like rubber hoses, plastic parts and sound-deadening materials. Never aim the spray head at the same point for a long time. This also applies to cleaning headlights and painted bumpers. Remember: the closer the nozzle is to the surface of the material, the greater the stress on the material. ■

Waxing

Wax protects the vehicle's paint.

- Use a manually applied car wax occasionally to protect the paint.

A good wax coating protects the vehicle paint to a large extent against the environmental factors listed under ⇒ *page 240*, "Washing" and even against slight scratches.

You can use a liquid car wax to protect your paint as soon as one week after your vehicle has been delivered.

Even if you regularly use a **waxing** process in automatic car washes, we recommend that you manually apply a coat of wax to give the paint extra protection, particularly if water no longer beads on the clean paint.

Protect plastic body parts with car wax in the same way as the vehicle body.

During warm weather dead insects tend to collect on the front bumper and on the forward area of the hood. They are much easier to remove from paint that is waxed *often*.

WARNING

Always read and heed all WARNINGS and other information
⇒ *page 240*.

Note

Do not use car wax on

- matte or anodized metal trim
- rubber or rubber-like trim. ■

Polishing

Polishing restores the gloss to the paint.

Polish your vehicle only if the paint has lost its shine and the gloss cannot be brought back with wax.

If the polish used does not contain preservative compounds, the paint must be waxed afterwards ⇒ *page 243*, "Waxing".

WARNING

Always read and heed all WARNINGS and other information
⇒ *page 240*.

Note

Do not treat matte anodized metal trim, plastic or rubber parts with polish or wax. ■

Trim strips

Metal trim needs special care.

For environmental reasons, Audi fabricates the bright trim strips and trim pieces from pure chromium-free aluminum.

Dirt and marks on the trim strips should be removed with a **pH-balanced** cleaning agent (do not use a chrome cleaner). Authorized Audi dealers carry cleaning products which have been tested for use on your vehicle and are not harmful to the environment.

To avoid corrosion on the exterior trim strips, only a pH-balanced solution should be used for the windshield washer.

WARNING

Always read and heed all WARNINGS and other information
⇒ *page 240*. ■

Plastic and vinyl

Plastic needs special care.

Use a clean, damp cloth or sponge to remove dust and light surface dirt. For other soil, use a lukewarm all-purpose cleaning solution or a mild saddle soap for vinyl trim. Remove water spots and traces of soap with a clean, damp cloth or sponge. Use a clean, soft cloth to rub dry.

Grease, tar or oil stains can be removed with a clean cloth or sponge soaked with all-purpose cleaner or with a solvent designed especially to clean vinyl.

Occasionally apply a colorless vinyl or leather preservative to retain the material's luster and pliability.

WARNING

Always read and heed all WARNINGS and other information
⇒ *page 240.* ■

Aluminum trim

Use only **neutral-pH** products to remove spots and deposits from aluminum surfaces. Chrome care products and alkaline cleaners will attack aluminum surfaces and can damage them over time.

WARNING

Always read and heed all WARNINGS and other information
⇒ *page 240.* ■

Touch-up paint

Minor paint damages should be touched up immediately.

- Use either a touch-up paint stick or spray paint to cover minor scratches and nicks.

Your authorized Audi dealer has touch-up paint for minor scratches and stone chips. Scratches should be touched up soon after they occur to prevent corrosion.

If a spot starts to rust, however, a simple touch-up job will not be enough. The affected surface must be sanded smooth and coated with an anti-rust primer before the painted finish can be restored.

The number for the original vehicle paint can be found on the vehicle identification label ⇒ *page 326.*

WARNING

Always read and heed all WARNINGS and other information
⇒ *page 240.* ■

Windows

Clear vision to all sides.

Clean all windows regularly to remove road film and car wash wax buildup.

- Remove snow from windows using a brush.
- Use a plastic ice scraper to remove ice from windows and mirrors.
- Remove other residue on the windows with a spray-on glass cleaner.
- Wipe the windows dry with a clean piece of cloth or kitchen paper towel.

The best way to remove snow from windows and mirrors is to use a brush. Use a non-abrasive **plastic ice scraper** - better still, a spray deicer - to remove **ice** from windows and mirrors.

The windows must not be cleaned with insect remover or wax since these can interfere with the function of the windshield wiper blades (chatter).

Oil, grease, or silicone residue can be removed with **glass cleaner** or **silicone remover**. However, wax residue requires the use of a specially formulated solvent. Please contact your authorized Audi dealer for advice on safe products for wax removal.

Windows should also be cleaned on the inside at regular intervals.

Never dry windows with the same chamois that you use to dry painted surfaces. Wax residue on the chamois can impair vision through the windows.

WARNING

- Always read and heed all WARNINGS and other information ⇒ *page 240*.
- The windshield must not be treated with water-repellent materials. They can increase glare under poor visibility conditions such as wetness, darkness, or when the sun is low on the horizon. In addition, they can cause the windshield wipers to chatter.

Note

- Never use warm or hot water to remove snow and ice from windows and mirrors. This could cause the glass to crack.
- To prevent damage to the wires of the rear defogger, do not place any adhesive stickers on the inside of the rear window over the wires.
- To help prevent dirt from scratching the window, always scrape in a forward direction - pushing the scraper away from you - never back and forth. ■

Weatherstrips

Complete car care includes the weatherstrips as well.

- Apply a suitable rubber conditioner to the weatherstrips from time to time.

To be able seal properly, the weatherstrips around the hood, doors, rear lid, etc. must remain pliable. Spray the weatherstrips with silicone or coat them with talcum powder or glycerine to retain the flexibility of the rubber and to protect them against freezing in the winter.

WARNING

Always read and heed all WARNINGS and other information
⇒ *page 240*.

Tips

Keep silicone sprays off the windshield to avoid wiper smear in rain. ■

Cast (light) alloy wheels

Cast (light) alloy wheels require special care.

- Wash the wheels with a sponge or hose brush every other week.
- For deep cleaning afterwards, use only a dedicated **acid-free** cast alloy wheel cleaner.
- Rub a coat of **liquid wax** onto the rims every three months. Be sure to reach and treat all parts of the rim.

To preserve the decorative appearance of the cast alloy wheels, some special care is necessary. In addition to road dirt and salt, ►

brake dust is also corrosive. If left on for too long, brake dust can cause pitting.

Use only special *acid-free* cleaners formulated for alloy rims. Safe products are available at your authorized Audi dealer. Never leave the cleaner on the rims longer than specified on the label. If not rinsed off promptly, the acid contained in some cleaners can attack the threads on the wheel bolts.

Never use abrasive or metal polishing cleaning agents. If the protective coating has been chipped, e.g. by kicked up road dirt, touch it up as soon as possible.

WARNING

- **Moisture and ice on brakes may affect braking efficiency**
⇒ *page 223, "General information"*. **Test the brakes carefully each time you wash the vehicle.**
- **Always read and heed all WARNINGS and other information**
⇒ *page 240.* ■

Body cavity sealing

The body cavity sealing does not need to be checked.

All body cavities which could be affected by corrosion have been thoroughly protected at the factory.

This sealing does not require any inspection or additional treatment. If any wax should seep out of the cavity when the ambient temperature is high, it can be removed with a plastic scraper and a suitable solvent.

WARNING

Solvents can be dangerous.

- **Benzine is flammable and toxic. If you use benzine for removing the wax, keep sparks, flame and lighted cigarettes away. Never**

WARNING (continued)

dump benzine on the ground, into open streams or down sewage drains.

- **Be sure to observe all safety and environmental regulations. Follow all instructions on the container.**
- **Always read and heed all WARNINGS and other information**
⇒ *page 240.* ■

Chassis

Have the undercoating checked for damage from time to time.

The lower body shell of your Audi is also thoroughly protected against corrosion.

Any damage to the undercoating caused by road hazards should be repaired promptly.

WARNING

Too much undercoating in the wrong places can cause a fire.

- **Do not apply additional undercoating or rustproofing on or near the exhaust manifold, exhaust pipes, catalytic converter or heat shields. While driving, the substance used for undercoating could overheat and cause a fire.**
- **Always read and heed all WARNINGS and other information**
⇒ *page 240.* ■

Care of interior

MMI display

- Clean the MMI display with a soft clean cloth and an LCD cleaner.

The MMI display can be cleaned with a professionally available “LCD cleaner”. The cloth should be slightly dampened with the cleaning fluid to clean the display.

Note

To avoid scratching the MMI display, you should never clean it dry. ■

MMI terminal

- First clean the MMI terminal with a brush to remove dust from the housing.
- Then wipe the MMI terminal with a clean, soft, slightly damp cloth.

The MMI terminal should be cleaned with a brush first so that no dirt is trapped between the buttons and the housing. We recommend giving the MMI terminal a final wipe with a cloth moistened with water and dish washing detergent.

Note

To prevent damage, make sure that no fluid ever gets into the MMI terminal. ■

Aluminum trim

Use only **neutral-pH** products to remove spots and deposits from aluminum surfaces. Chrome care products and alkaline cleaners will attack aluminum surfaces and can damage them over time.

WARNING

Always read and heed all WARNINGS and other information
⇒ *page 240.* ■

Fabrics and fabric coverings

Fabrics and fabric coverings (e.g. seats, door trim panels, etc.) should be cleaned at regular intervals with a vacuum cleaner. This removes surface dirt particles which could become embedded in the fabric through use. Steam cleaners should not be used, because the steam tends to push the dirt deeper into the fabric and lock it there.

Normal cleaning

Generally, we recommend using a soft sponge or a lint-free microfiber cloth to the clean fabric. Brushes should only be used for carpets and floor mats, since other fabric surfaces could be harmed by brushes.

Normal surface stains can be cleaned using a commercially available foam cleaner. Spread the foam on the surface of the fabric with a soft sponge and work it in gently. Do not saturate the fabric. Then pat the foam dry using absorbent, dry cloths (e.g. microfiber cloth) and vacuum it after it has dried completely.

Cleaning stains

Stains caused by beverages (e.g. coffee, fruit juice, etc.) can be treated with a mild detergent solution. Apply the detergent solution with a sponge. In the case of stubborn stains, a detergent paste can be applied directly to the stain and worked into the fabric. After-

wards, use copious amounts of clean water to remove the remaining detergent. Apply the water with a damp cloth or sponge and pat the fabric dry with an absorbent, dry cloth.

Stains from chocolate or makeup should have detergent paste rubbed into them. Afterwards, remove the soap with water (damp sponge).

Alcohol can be used to treat stains from grease, oil, lipstick or a ball-point pen. Melted grease or dye must be patted off using absorbent material. It may be necessary to retreat the areas with detergent paste and water.

In the case of general soiling of the upholstery and cover material, we recommend hiring a specialist that has the equipment to clean the seat covers and other fabric surfaces by shampooing and spray extraction.

WARNING

Always read and heed all WARNINGS and the information
⇒ *page 240.*

Tips

Open Velcro fasteners on your clothing can damage the seat cover. Please make sure that Velcro fasteners are closed. ■

Plastic parts and instrument panel

Always use a clean cloth moistened in clear water to clean these areas. For persistent dirt use an Audi approved **solvent-free** plastic cleaner/protectant.

WARNING

Solvents can change the properties of some plastics and make it harder for the airbag to deploy.

WARNING (continued)

- Never clean the instrument panel or the surface of airbag modules with cleaning products that contain solvents.
- Products containing solvents will make the surface of this part porous.
- Serious injuries can result if plastic parts come loose when the airbag is deployed.
- Always read and heed all WARNINGS and other information
⇒ *page 240.*

Note

Cleaning agents containing solvents will attack the material and can change the way it behaves. ■

Applies to vehicles: with natural leather

Natural leather

Audi makes great efforts to maintain the properties, natural look and feel of interior leather.

General

We offer many different types of leather on our vehicles. Most are different types of nappa leather, which has a smooth surface and comes in various colors.

The intensity of the color determines the visual characteristics and appearance. If the surface of the leather has a typical natural look, then the leather is a nappa leather that has been left in a relatively natural condition. This leather offers particularly good comfort and breathes well. Fine veins, closed grains, insect bites, skin folds, and subtle variations in color remain visible. These characteristics demonstrate that the material is natural.

Natural nappa leather is not covered by a color finish. It is therefore more sensitive to soiling and wear, which is something you need to ►

consider if children, animals or other factors might prove to be particularly hard on the leather.

By contrast, leather types that are covered by a colored finish layer are more durable. This has a positive effect on the leather's resistance to wear and soiling in daily use. On the other hand, the typical characteristics of natural leather are barely or not apparent. However, this does not mean that the leather itself is of inferior quality.

Care and handling

Because of the exclusive nature of the types of leather that Audi uses and their unique properties (such as sensitivity to oils, grease, soiling, etc.), you will need to be somewhat careful with these leathers, and a certain type of care is required. For example, dark clothing materials can discolor leather seats (especially if such clothing is damp and was not dyed correctly). Dust and dirt particles in pores, folds, and seams can have an abrasive effect and can damage the leather surface as well as weaken seams.

The leather should be cleaned regularly as needed. After having been used for a relatively long time, your leather seats will acquire a rich aged finish. This is a characteristic of natural leather and a sign of true quality.

In order to maintain the value of this natural product over the life of your vehicle, you should follow the recommendations below:



Note

- To keep your leather from bleaching out, do not allow it to be exposed to bright sunlight for long periods of time. If you have to leave the vehicle parked outside for long periods, cover the leather to protect it from direct exposure to sunlight.
- Sharp objects on clothing, such as zippers, rivets or sharp pieces on belts can leave permanent scratches or scrape marks on the surface of the leather.



Tips

- After each time you clean the leather and at regular intervals, use a leather preservative creme that contains UV-blockers and that works into the leather. This creme will nourish and moisturize the leather, helping it to breathe and stay supple. It also helps to build up a protective coating on the surface.
- Clean the leather every 2 - 3 months, and clean any areas that get soiled.
- Remove fresh marks made by ballpoint pens, ink, lipstick, shoe polish, etc. as soon as possible.
- Preserve the color of the leather as needed by using a special colored leather care creme to touch up areas of uneven color. ■

Applies to vehicles: with natural leather

Cleaning and caring for leather upholstery and trim

Natural leather requires special care and attention.

Normal cleaning

- Clean soiled areas with a slightly moistened cotton or woolen cloth.

More stubborn dirt

- More stubborn dirt can be removed using a cloth saturated with a mild soap solution (2 tablespoons mild liquid soap).
- Never allow the soap solution to saturate the leather, and make certain that no water soaks into the seams.
- Wipe off the soap solution with a soft, dry cloth. ▶

Cleaning spots

- Remove fresh **water-based** spots (such as coffee, tea, juices, blood) with an absorbent cloth or paper towel.
- Remove fresh **grease or oil-based spots** (such as butter, mayonnaise, chocolate) with an absorbent cloth or paper towel, or use the cleaner from the leather care kit if the spot has not yet penetrated into the surface of the leather.
- Use an oil/grease dissolving spray, if **oil/grease spots have dried on**.
- Remove specific kinds of spots (ballpoint pen, felt marker, fingernail polish, water-based paint, shoe polish, etc.) with a spot remover specifically formulated for leather.

Leather care

- Every half year use an approved leather care product (available from your authorized Audi dealer) to care for the leather.
- Apply the product very sparingly.
- Wipe it off with a damp cloth.

If you have any questions about cleaning and caring for the leather in your vehicle, it is best to contact your authorized Audi dealer, who will be glad to help you and tell you about our full range of leather care products, such as:

- Leather cleaning and care kit
- Creams to care for colored leather
- Spot removers for ballpoint pens, shoe polish, etc.
- Oil/grease dissolving spray
- New and upcoming products.



WARNING

Always read and heed all **WARNINGS** and other information
⇒ *page 240*.



Note

- Never use chemical solvents (e.g. lighter fluid, turpentine), waxes, shoe polish or similar products on the leather surfaces in your Audi.
- To avoid damage, have stubborn stains removed by a commercial cleaning specialist. ■

Applies to vehicles: with Alcantara upholstery

Cleaning Alcantara® (synthetic suede)

Removing dust and dirt

- Moisten a cloth, *squeeze out excess water* and wipe down the seat surfaces.

Removing stains

- Moisten a cloth with lukewarm water or with diluted **ethyl (rubbing) alcohol**.
- Dab at the stain. Start at the outside and work inwards.
- Once the stain is no longer visible, use a soft dry cloth or tissue to soak up the moisture.

Do not use leather cleaning products on Alcantara.

You may use a suitable shampoo for removing dust and dirt.

Dust and grit in the pores and seams can scratch and damage the surface. If the car is left standing in the sun for long periods, the leather should be protected against direct sunlight to prevent it

from fading. Slight color variations will develop in normal use and are not an indication of material deterioration.

Note

- Never use chemical solvents (e.g. lighter fluid, turpentine), waxes, shoe polish or similar products on Alcantara® surfaces.
- To avoid damage, have stubborn stains removed by a commercial cleaning specialist.
- Do not use brushes, stiff sponges or similarly abrasive cleaning aids. ■

Safety belts

Only well-maintained safety belts work reliably when needed.

- Keep belts clean.
- For cleaning, use a mild soap and water solution. Let belts dry thoroughly and away from direct sunlight.
- Do not allow inertia reel safety belts to retract before they are completely dry.
- Check the condition of your safety belts *regularly*.

Heavily soiled safety belts may not retract properly.

WARNING

Damaged safety belts can break in a crash.

- **Anything that might damage your safety belts could mean that you and your passengers would not be adequately protected in an accident.**
- **Safety belt performance depends on correct installation. Never remove belts from the vehicle to clean them.**

WARNING (continued)

- **Do not use chemical cleaning agents, bleach or dyes. They have corrosive properties which weaken the webbing.**
- **When cleaning your safety belts, inspect them for damage. If you discover damage, see your authorized Audi dealer.**
- **Always read and heed all WARNINGS and other information**
⇒ **page 240.** ■

Engine compartment

Be especially careful when cleaning the engine compartment.

Always switch off the ignition before cleaning the engine ⇒ .

Plenum panel

Remove leaves from the plenum panel in front of the windshield under the engine hood. This prevents the water drain holes from becoming blocked, and it prevents debris from entering the vehicle interior through the heating and ventilation ducts.

Corrosion protection

The engine compartment and transmission have been corrosion-protected at the factory.

Good anti-corrosion treatment is very important, particularly in the winter. If the vehicle is frequently driven on salt treated roads, the entire engine compartment and plenum panel should be thoroughly cleaned at the end of winter and retreated to prevent salt damage. At the same time, the underside of the vehicle should be washed as well.

If the engine compartment is cleaned at any time with grease removing solutions¹⁾, or if you have the engine washed, the anti-corrosion treatment is almost always removed as well. It is therefore ►

¹⁾ Use only the correct cleaning solutions. Never use gasoline or diesel fuel.

essential to have a long-lasting corrosion protection reapplied to all surfaces, seams, joints and components in the engine compartment.

 **WARNING**

Be aware: The engine compartment of any motor vehicle is a potentially hazardous area.

- **Before working in the engine compartment, be sure to read the information ⇒ *page 251*.**
- **Before reaching into the front plenum panel, always remove the ignition key. Otherwise, the windshield wiper system could unintentionally be switched on, possibly causing personal injury from the moving wiper linkage.**
- **Never reach into the area around or touch the radiator fan. The auxiliary fan is temperature controlled and can switch on suddenly - even when the ignition is off.**
- **Do not wash, wax or dry the engine with the engine running. Moving or hot parts could injure you.**
- **Do not clean the underside of the chassis, fenders, wheel covers, or other hard to reach parts without protecting your hands and arms. You may cut yourself on sharp-edged metal parts.**
- **Always read and heed all WARNINGS and other information ⇒ *page 240*. ■**

Fuel supply and filling your fuel tank

Gasoline

Fuel supply

Using the right fuel helps keep the environment clean and prevents engine damage.

Fuel recommendation

The fuel recommended for your vehicle is **unleaded premium** grade gasoline. See also ⇒ *page 329, "Data"*. Audi recommends using TOP TIER Detergent Gasoline with a minimum octane rating of 91 AKI (95 RON). For more information on TOP TIER Detergent Gasoline, please go to the official website (www.toptiergas.com).

The recommended gasoline octane rating for your engine can also be found on a label located on the inside of the fuel filler flap. This rating may be specified as AKI or RON.

Your vehicle may also be operated using unleaded regular gasoline with a minimum octane rating of 87 AKI/91 RON. However, using 87 AKI/91 RON octane fuel will slightly reduce engine performance.

Use unleaded gasoline only. Unleaded gasoline is available throughout the USA, Canada, and in most European countries. We recommend that you do not take your vehicle to areas or countries where unleaded gasoline may not be available.

For more information on refueling your vehicle, see ⇒ *page 254*.

Octane rating

Octane rating indicates a gasoline's ability to resist engine damaging "knock" caused by premature ignition and detonation. Therefore, buying the correct grade of gasoline is very important to help prevent possible engine damage and a loss of engine performance.

Gasoline most commonly used in the United States and Canada has the following octane ratings that can usually be found on the filler pump:

- Premium Grade: 91 - 96 AKI
- Regular Grade: 87 - 90 AKI

Explanation of the abbreviations:

AKI = **A**nti **K**nock **I**ndex = $(R+M)/2 = (RON+MON)/2$

RON = **R**esearch **O**ctane **N**umber

MON = **M**otor **O**ctane **N**umber.



Note

- Do not use any fuel with octane ratings lower than 87 AKI or 91 RON otherwise expensive engine damage will occur.
- Do **not** use leaded gasoline. The use of leaded gasoline will severely damage your vehicle's catalytic converter and its ability to control exhaust emissions. ■

Blended gasoline

Use of gasoline containing alcohol or MTBE (methyl tertiary butyl ether)

You may use unleaded gasoline blended with alcohol or MTBE (commonly referred to as oxygenates) if the blended mixture meets the following criteria:

Blend of gasoline methanol (wood alcohol or methyl alcohol)

- Anti-knock index must be 87 AKI or higher.
- Blend must contain no more than 3% methanol.
- Blend must contain more than 2% co-solvents.

Blend of gasoline and ethanol (grain alcohol or ethyl alcohol)

- Anti-knock index must be 87 AKI or higher.
- Blend must not contain more than 10% ethanol.

Blend of gasoline and MTBE

- Anti-knock index must be 87 AKI or higher.
- Blend must contain not more than 15% MTBE.

Seasonally adjusted gasoline

Many gasoline grades are blended to perform especially well for winter or summer driving. During seasonal change-over, we suggest that you fill up at busy gas stations where the seasonal adjustment is more likely to be made in time.

**Note**

- Methanol fuels which do not meet these requirements may cause corrosion and damage to plastic and rubber components in the fuel system.
- Do not use fuels that fail to meet the specified criteria in this chapter.
- If you are unable to determine whether or not a particular fuel blend meets the specifications, ask your service station or its fuel supplier.
- Do not use fuel for which the contents cannot be identified.
- Fuel system damage and performance problems resulting from the use of fuels different from those specified are not the responsibility of Audi and are not covered under the New Vehicle or the Emission Control System Warranties.
- If you experience a loss of fuel economy or driveability and performance problems due to the use of one of these fuel blends, we recommend that you switch to unblended fuel. ■

Gasoline additives

A major concern among many auto manufacturers is carbon deposit build-up caused by the type of gasoline you use.

Although gasoline grades differ from one manufacturer to another, they have certain things in common. All gasoline grades contain substances that can cause deposits to collect on vital engine parts, such as fuel injectors and intake valves. Although most gasoline brands include additives to keep engine and fuel systems clean, they are not equally effective.

Audi recommends using TOP TIER Detergent Gasoline. For more information on TOP TIER Detergent Gasoline, please go to the official website (www.toptiergas.com).

After an extended period of using inadequate fuels, built-up carbon deposits can rob your engine of peak performance.

**Note**

Damage or malfunction due to poor fuel quality is not covered by the Audi New Vehicle Limited Warranty. ■

Fuel tank**Fuel filler neck**

The fuel filler neck is located on the right rear side panel behind the fuel filler flap.

If the power locking system should fail, you can still open the flap manually - for detailed instructions see ⇒ *page 257*.

You can find the fuel tank capacity of your vehicle in **Technical Data** ⇒ *page 329*. ▶

The label on the inside of the fuel filler flap tells you the correct fuel for your vehicle. For more information about fuel specifications, see ⇒ *page 253*.

Your vehicle fuel tank has an on-board refuelling vapor recovery system. This feature helps to prevent fuel vapors from escaping from the tank and polluting the environment while you refuel your vehicle. In order to fill the tank properly while protecting the environment, please follow this refueling procedure carefully.

WARNING

Under normal operating conditions, never carry additional fuel containers in your car. Gas canisters and other containers used to transport fuel can be dangerous. Such containers, full or empty, may leak and could cause a fire in a collision. If you must transport fuel to use for your lawn mower, snow blower, etc., be very careful and always observe local and state laws regarding the use, transportation and storage of such fuel containers. Make certain the container meets industry standards (ANSI/ASTM F852 - 86).

Note

Never drive your vehicle until the fuel tank is completely empty. The irregular supply of fuel can cause misfiring. Gasoline could enter the exhaust system and damage the catalytic converter. ■

Refuelling



Fig. 196 Right rear vehicle side: Opening the fuel filler flap

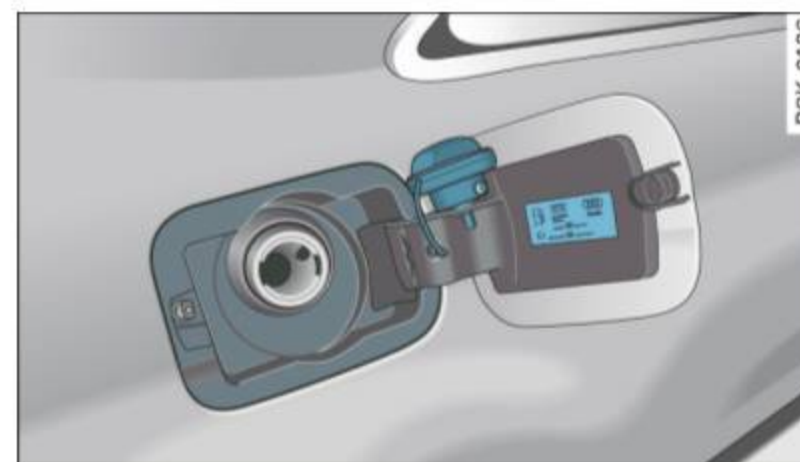


Fig. 197 Fuel filler flap with attached fuel cap

When activating the central locking, the fuel filler flap is automatically unlocked or locked. Refuel the vehicle with the ignition turned *off*.

Taking the fuel cap off

- Turn off the ignition.
- Press the left side of the fuel filler flap to open it ⇒ fig. 196 -arrow-.
- Unscrew fuel cap counter-clockwise and hang it on the fuel filler flap ⇒ fig. 197. ▶

Refuelling procedure

- Insert the fuel nozzle from the gasoline pump into the fuel filler neck as far as it will go.
- Select a medium refuelling rate so that the nozzle switches off automatically when the tank is full.

Putting the fuel cap back on

- After filling your tank, twist the fuel cap clockwise as far as it will go.
- Close the fuel filler flap.

To avoid fuel spilling or evaporating from the fuel tank always close fuel cap properly and completely.

WARNING


Improper refueling or handling of fuel can cause fire, explosion and severe burns.

- Fuel is highly flammable and can cause severe burns and other injuries.
- Failure to shut the engine off while refueling and/or to insert the pump nozzle fully into the fuel filler neck could cause fuel to spray out of filler neck or to overflow. Fuel spray and overflowing fuel can cause a fire.
- Never use a cellular telephone while refueling. The electromagnetic radiation can cause sparks that can ignite fuel vapors and cause a fire.
- Never get back into your vehicle while refueling. If in exceptional circumstances you must get back in your vehicle while refueling, make certain that you close the door and touch metal to discharge static electricity before touching the filler nozzle again. Static electricity can cause sparks that can ignite fuel vapors released during refueling.

WARNING (continued)

- Never smoke or have an open flame anywhere in or near your vehicle when refueling or filling a portable fuel container.
- For your safety, we strongly recommend that you do not travel with a portable fuel container in your vehicle. The container, full or empty may leak and could cause a fire, especially in a crash.
- If, under exceptional circumstances, you must transport a portable fuel container, please observe the following:
 - Never fill a portable fuel container while it is anywhere in or on the vehicle (for example, in the luggage compartment, or on the trunk). Static electricity can build up while filling and can ignite fuel vapors causing a fire.
 - Always place a portable fuel container on the ground before filling.
 - Always keep the filler nozzle completely inside the portable container before and during filling.
 - If filling a portable container made of metal, the filler nozzle must always be in contact with the container. This will help prevent static electricity from discharging and cause a fire.
 - Never spill fuel inside the vehicle or luggage compartment. Fuel vapors are highly flammable.
 - Always observe local and state/provincial laws regarding the use, storage and transportation of fuel containers.
 - Make certain the fuel container meets industry standards (ANSI / ASTM F852–86).

Note

If any fuel has spilled onto the car, it should be removed immediately to prevent damage to the paint. 

For the sake of the environment

As soon as the correctly operated nozzle switches off automatically for the first time, the tank is full. Do not try to add more fuel because fuel may spill out. In addition, the expansion space in the fuel tank will be filled - causing the fuel to overflow when it becomes warm and pollute the environment.

Tips

- Running your engine while refuelling may cause vapors to escape or even cause fuel to spill out of the tank. This would then shut off the fuel nozzle before the tank is full.
- Do not refuel your vehicle with the ignition turned on. The fuel gauge may otherwise not indicate the correct fuel level after refueling.
- The fuel filler flap of your vehicle is not locked when you lock the vehicle from the inside. ■

Unlocking the fuel filler flap by hand

You can open the fuel filler flap by hand if the power locking system should fail.

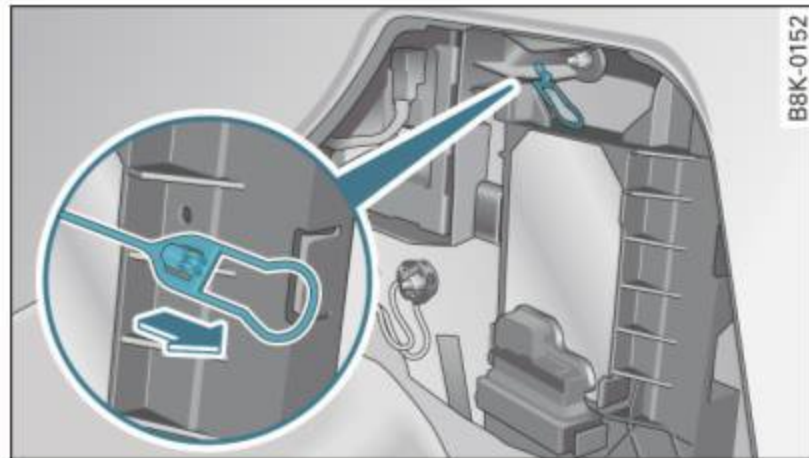


Fig. 198 Luggage compartment: Emergency opening of fuel filler flap

The emergency opening mechanism is located behind the right side trim panel in the luggage compartment.

- Open the right side trim panel.
- Loosen the strap from its bracket and pull on it ⇒ fig. 198. Now you can open the fuel filler flap as usual. ■

Checking and filling

Engine hood

Releasing the engine hood

The engine hood is released from inside the vehicle.

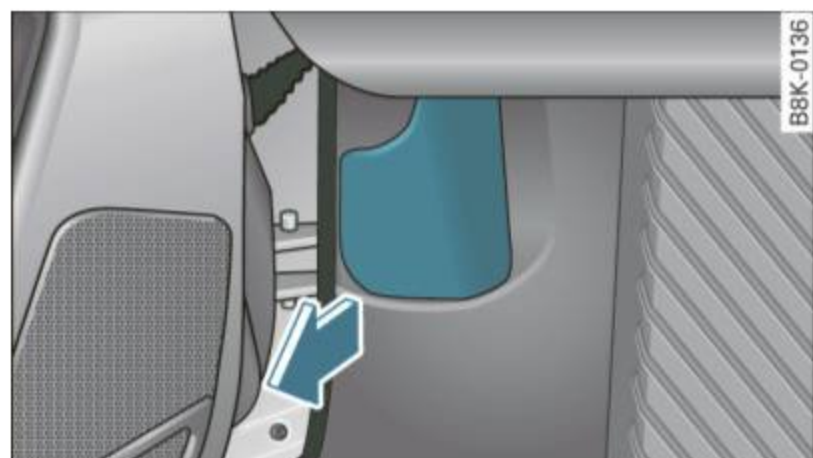


Fig. 199 Driver's side footwell: engine hood release lever

- Open the driver's door.
- Pull the release lever on the left under the instrument panel ⇒ fig. 199 in the direction of the arrow.

The hood pops up slightly under spring pressure. ■

Opening the engine hood

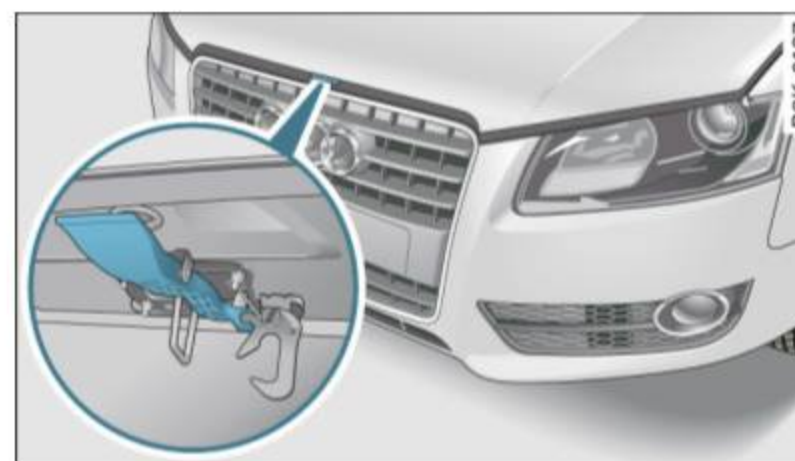


Fig. 200 Release lever under the engine hood

Before opening the engine hood, make sure that the windshield wipers are flat against the windshield. Otherwise, they could damage the paint on the hood.

- Lift the hood slightly ⇒ ⚠.
- Pull up on the release under the hood ⇒ fig. 200. This releases the catch.
- Open the hood all the way.


The hood is kept in the open position by two gas struts.

⚠ WARNING

Hot engine coolant can burn you.

- To reduce the risk of being burned, never open the hood if you see or hear steam or coolant escaping from the engine compartment. Wait until no steam or coolant can be seen or heard before carefully opening the hood. ■

Closing the engine hood

- Pull the hood down until the pressure from the struts is reduced.
- Let the hood *drop down* and latch in place. *Do not try to push it shut*; it may fail to engage ⇒ .


WARNING

A hood that is not completely latched could fly up and block your view while driving.

- When you close the engine hood, check it to make sure the safety catch has properly engaged. The hood should be flush with the surrounding vehicle body parts.
- If you notice while driving that the hood is not secured properly, stop at once and close it. ■

Working in the engine compartment

Be especially careful whenever you work in the engine compartment.

Whenever you must perform any work in the engine compartment, for example checking and filling different fluids, there is a risk of injury, burns and accidents. To prevent personal injury always observe the following WARNINGS. The engine compartment of any vehicle is a hazardous area ⇒ .

WARNING

To help avoid injury, before you check anything under the hood:

- Turn off the engine.
- Remove the ignition key.
- Apply the parking brake.

WARNING (continued)

- Move selector lever of automatic transmission to "P" (Park); put manual transmission in Neutral.
- Always let the engine cool down. Hot components will burn skin on contact.
- To reduce the risk of being burned, never open the hood if you see or hear steam or coolant escaping from the engine compartment. Wait until no steam or coolant can be seen or heard before carefully opening the hood.
- Keep children away from the engine compartment.
- Never spill fluids on hot engine components. They can cause a fire.
- Never touch the radiator fan. The auxiliary electric fan is temperature controlled and can switch on suddenly.
- Never open the coolant reservoir cap when the engine is still warm. The coolant system is pressurized and hot coolant could spray out.
- Protect your face, hands and arm from steam or hot engine coolant by placing a thick rag over the cap when you open the coolant reservoir.
- If work on the fuel system or the electrical system is necessary:
 - Always disconnect the battery.
 - Never smoke or work near heaters or open flames. Fluids in the engine compartment could start a fire.
 - Keep an approved fire extinguisher immediately available.
- To avoid electrical shock and personal injury while the engine is running or being started, never touch:
 - Ignition cables
 - Other components of the high voltage electronic ignition system.
- If you must perform a check or repair with the engine running: ▶

⚠ WARNING (continued)

- First, fully apply the parking brake, move selector lever of automatic transmission to “P” (Park); put manual transmission in Neutral.
- Always use extreme caution to prevent clothing, jewelry, or long hair from getting caught in the radiator fan, V-belts or other moving parts, or from contacting hot parts. Tie back hair before starting, and do not wear clothing that will hang or droop into the engine.
- Minimize exposure to emission and chemical hazards ⇒ **⚠**.

⚠ WARNING

California Proposition 65 Warning:

- Engine exhaust, some of its constituents, and certain vehicle components contain or emit chemicals known to the State of California to cause cancer and birth defects and reproductive harm. In addition, certain fluids contained in vehicles and certain products of component wear contain or emit chemicals known to the State of California to cause cancer and birth defects or other reproductive harm.
- Battery posts, terminals and related accessories contain lead and lead compounds, chemicals known to the State of California to cause cancer and reproductive harms. Wash hands after handling.

! Note

When adding fluids, always make sure that they are poured into the proper container or filler opening, otherwise serious damage to vehicle systems will occur.

🌸 For the sake of the environment

To detect leaks in time, inspect the vehicle floor pan from underneath regularly. If you see spots from oil or other vehicle fluids, have your vehicle inspected by an authorized Audi dealer. ■

Engine compartment

Engine compartment

These are the most important items that you can check.

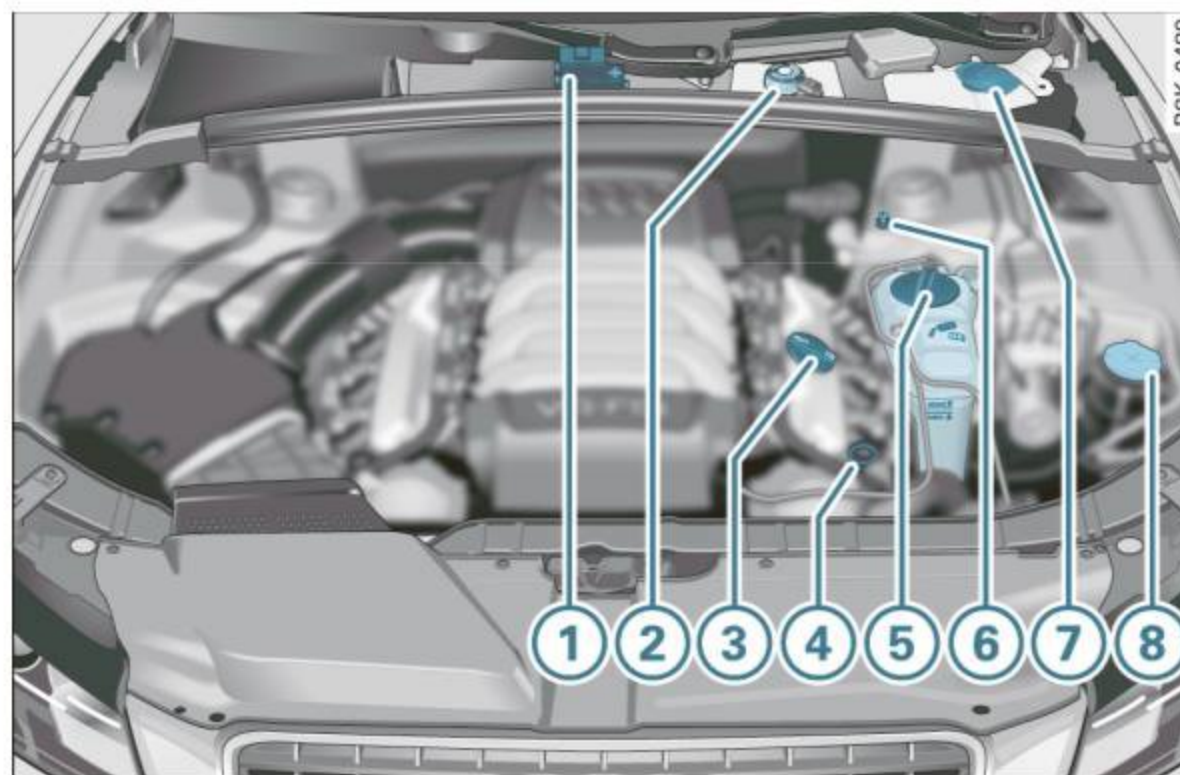


Fig. 201 Typical layout for containers, engine oil dipstick and engine oil filler cap

①	Jump start point (+) under a cover	273, 318
②	Brake fluid reservoir (🟡)	269
③	Engine oil filler cap (🛢️)	264
④	Engine oil dipstick (orange)*	263 ▶

- ⑤ Coolant expansion tank (📏) 267
- ⑥ Jump start point (-) with hex head screw 273, 318
- ⑦ Windshield/headlight washer container (🚿) 275
- ⑧ Power steering reservoir 225

WARNING

Before you check anything in the engine compartment, always read and heed all WARNINGS ⇒  in "Working in the engine compartment" on page 259. ■

Engine oil

Engine oil specifications

The engine oil used in your Audi needs the right kind of oil.

The engine in your Audi is a sophisticated powerplant that was built to exacting specifications. This engine needs the right kind of engine oil that meets specifications regarding quality and viscosity so that it can run smoothly and reliably. Choosing the right oil and changing oil within the time and mileage intervals printed in your vehicle's Warranty & Maintenance booklet matters a lot more today than it did years ago. Audi has developed a special quality standard for engine oil that will help assure that your vehicle's engine will get the lubrication it needs for proper operation.

Modern engine lubrication has taken a quantum leap in the last few years. Many synthetic oils available today provide better engine lubrication that can outlast traditional petroleum-based oils, making them a smart choice for use throughout the life of your Audi.

Whether you use synthetic or petroleum-based engine oil, the oil that you use must conform to Audi's oil quality standard VW 502 00 to help keep your vehicle's engine running smoothly and help

prevent the formation of harmful deposits, sometimes called "sludge," that over time can lead to expensive repairs.

At the time of printing, engine oils available in the U.S. and Canada that meet the exacting specifications of Audi oil standard VW 502 00 are synthetic engine oils. This does not mean, however, that every synthetic engine oil will meet Audi oil standard VW 502 00. So always be sure that you use an approved oil.

To help prevent the formation of harmful deposits use only oil with the following specifications printed on the oil container:

Audi oil standard VW 502 00

Oil container labels may carry the specification singly or in combination with other designations and oil quality standards.

Viscosity

Engine oils are graded according to their viscosity. The proper viscosity grade oil for your engine depends on climactic or seasonal conditions where you drive. You can use oil with a viscosity grade of SAE 5W40 across all temperature ranges for normal driving conditions.

However, if engine oil viscosity grade SAE 5W40 is not available, you can also use viscosity grade SAE 5W-30 or SAE 0W-40 as long as it meets Audi oil quality standard VW 502 00 specifications.

Because engine oil that meets the Audi oil standard may not be available everywhere when you need it, we strongly recommend that you always carry with you an extra quart (liter) of oil that expressly conforms to the VW 502 00 specification, in case you have to top off the oil while on the road.

Only if the level of the oil is at or below the minimum mark on the oil dipstick - and no oil that expressly conforms to Audi oil standard VW 502 00 specifications is available - may you top off with a high quality engine oil, preferably synthetic-based, that meets ACEA A3, ACEA A5 or ACEA B5, API SL or ILSAC GF-3 specifications, but even then, only in viscosity grades SAE 5W-40, SAE 5W-30, or SAE 0W-40. However, during the entire time between oil change intervals, never ►

top off with more than a total of 0.5 qt/liter engine oil that does not conform to Audi oil specification VW 502 00.

For more information about engine oil that has been approved for your vehicle, please contact either your authorized Audi dealer or Audi Customer Relations at 1 (800) 822-2834 or visit our web site at www.audiusa.com or www.audicanada.ca. Here you will also find a current list of oils (manufacturers, brand names etc.) that conform to Audi oil standard VW 502 00.

Changing the engine oil

The engine oil and oil filter must be changed according to the mileage (kilometers) and time intervals specified in your vehicle's Warranty & Maintenance booklet. Do not exceed these intervals – harmful deposits from old engine oil can reduce engine performance and can lead to expensive engine repairs.

Changing the oil at the recommended intervals is so very important because the lubricating properties of oil decrease gradually during normal vehicle use. If you are not sure when you have your oil changed, ask your authorized Audi Service Advisor.

Under some circumstances the engine oil should even be changed more frequently. Change oil more often if you drive mostly short distances, operate the vehicle in dusty areas or mostly under stop-and-go traffic conditions, or when you use your vehicle where temperatures stay below freezing point for long periods.

Detergent additives in the oil will make fresh oil look dark after the engine has been running for a short time. This is normal and is not a reason to change the oil more often than recommended.

Damage or malfunctions due to lack of maintenance

It is essential that you change your oil at the recommended intervals using only engine oil that complies with Audi oil standard VW 502 00. Your Limited New Vehicle Warranty does not cover damage or malfunctions due to failure to follow recommended maintenance and use requirements as set forth in the Audi Owner's Manual and Warranty & Maintenance booklet. Your dealer will have to deny warranty coverage unless you present to the dealer proof in

the form of Service or Repair Orders that all scheduled maintenance was performed in a timely manner. ■


Engine oil consumption

The engine in your vehicle depends on an adequate amount of oil to lubricate and cool all of its moving parts.


In order to provide effective lubrication and cooling of internal engine components, all internal combustion engines consume a certain amount of oil. Oil consumption varies from engine to engine and may change significantly over the life of the engine. Typically, engines with a specified break-in period (see ⇒ *page 229*) consume more oil during the break-in period than they consume after oil consumption has stabilized.

Under normal conditions, the rate of oil consumption depends on the quality and viscosity of the oil, the RPM (revolutions per minute) at which the engine is operated, the ambient temperature and road conditions. Further factors are the amount of oil dilution from water condensation or fuel residue and the oxidation level of the oil. As any engine is subject to wear as mileage builds up, the oil consumption may increase over time until replacement of worn components may become necessary.

With all these variables coming into play, no standard rate of oil consumption can be established or specified. There is no alternative to regular and frequent checking of the oil level, see **Note**.

If the yellow engine oil level warning symbol in the instrument cluster  lights up, you should check the oil level as soon as possible *with the oil dipstick* ⇒ *page 263*. Top off the oil at your earliest convenience ⇒ *page 264*.


WARNING

Before you check anything in the engine compartment, always read and heed all WARNINGS ⇒  in "Working in the engine compartment" on *page 259*.

! Note

Driving with an insufficient oil level is likely to cause severe damage to the engine.

i Tips

- The oil pressure warning display  is not an indicator of the oil level. Do not rely on it. Instead, check the oil level in your engine at regular intervals, preferably each time you refuel, and always before going on a long trip.
- If you have the impression your engine consumes excessive amounts of oil, we recommend that you consult an authorized Audi dealer to have the cause of your concern properly diagnosed. Keep in mind that the accurate measurement of oil consumption requires great care and may take some time. An authorized Audi dealer has instructions about how to measure oil consumption accurately. ■

Checking the engine oil level (with oil dipstick)

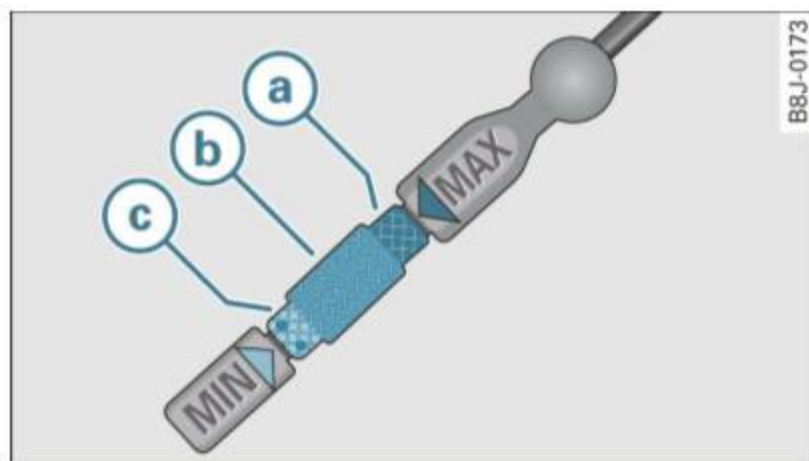


Fig. 202 Illustration of principle 1: Markers on oil dipstick

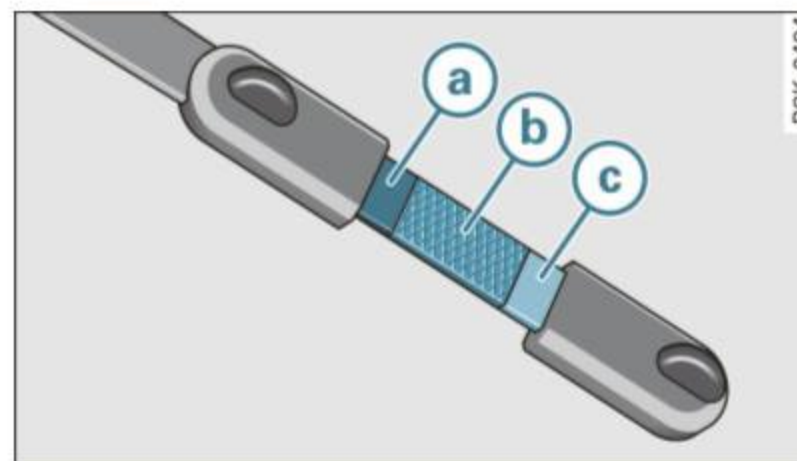



Fig. 203 Illustration of principle 2: Markers on oil dipstick

Before you check anything in the engine compartment, **always read and heed all WARNINGS** ⇒  in “Working in the engine compartment” on *page 259*.

Determining oil level

- Park your vehicle so that it is horizontally level.
- While at operating state temperature, briefly let the engine run at idle and then shut it off.
- Wait approx. two minutes.
- Pull out the oil dipstick. Wipe off the oil dipstick with a clean cloth, and slide it back in as far as it will go.
- Pull it back out and read off the oil level ⇒ fig. 202 or ⇒ fig. 203. Top off the engine oil, if applicable ⇒ *page 264*.


Oil level within range **a**

- Do *not* add oil.

Oil level within range **b**

- You *can* add oil. Afterwards, the oil level should be within range **a**.

Oil level within range

- You *must* add oil. *Afterwards*, the oil level should be within range .

The oil level needs to be checked at regular intervals. The best times to do this are whenever you refuel and prior to long trips. ■


Applies to vehicles: without oil dipstick

Checking the engine oil level (without oil dipstick)



Fig. 204 MMI Display: Oil level indicator

Read oil level

- Select: Function button  > **Oil level**.
- Park your vehicle so that it is horizontally level.
- While at operating state temperature, briefly let the engine run at idle and then shut it off.
- Wait approx. two minutes.
- Read the oil level in the MMI Display ⇒ fig. 204. Add engine oil if the bar of the oil level indicator is near “min” ⇒ *page 264*

Depending on the way the vehicle is driven and the operating conditions, oil consumption can be up to a 1/2 quart per 600 miles (0.5 liter per 1000 km). Consumption may be higher within the first 3000 miles (5000 km).


Tips


The oil level indicator in the MMI Display is only an information display. If the oil level is too low, a minimum oil warning appears in the instrument cluster. Add oil ⇒ *page 264*. If the hood has been opened, the current oil level is shown in the instrument cluster the next time the ignition is switched on. ■

Adding engine oil



Fig. 205 Engine compartment: Oil filler cap location

Before you check anything in the engine compartment, **always read and heed all WARNINGS** ⇒  in “Working in the engine compartment” on *page 259*.


- Unscrew the cap  to the engine oil filling hole ⇒ fig. 205.
- Carefully top off with the appropriate oil in 0.5 liter doses.
- Check the oil level again after two minutes ⇒ *page 263*.
- Top off the oil again, if necessary. ►

- Screw the cap back on the filling hole and slide the oil dipstick in as far as it will go.

WARNING

- While topping off, the oil must not come in contact with hot engine parts - fire hazard!
- The oil filler cap must be properly secured to prevent oil from being sprayed on the hot engine and exhaust system when the engine is running - fire hazard!
- If your skin has come in contact with the engine oil, you must subsequently cleanse it thoroughly.

Note


- The oil level must not be above range  - danger of converter or engine damage! Contact an authorized Audi dealer or other qualified workshop to draw off oil, if necessary.
- Audi does not recommend the use of oil additives. They may damage the engine and adversely affect your New Vehicle Warranty.

For the sake of the environment

- Under no circumstances can the oil come in contact with the sewage network or the soil.
- Observe and follow legal regulations when disposing of empty oil containers. ■

Changing the engine oil

We recommend that have your oil changed by an authorized Audi dealer or a qualified service station.

Before you check anything in the engine compartment, **always read and heed all WARNINGS** ⇒  in "Working in the engine compartment" on page 259.

The engine oil must be changed according to the intervals specified in your Warranty & Maintenance booklet. This is very important because the lubricating properties of oil diminish gradually during normal vehicle use.

Under some circumstances the engine oil should be changed more frequently. Change oil more often if you drive mostly short distances, operate the vehicle in dusty areas or under predominantly stop-and-go traffic conditions, or have your vehicle where temperatures remain below freezing for extended periods.

Detergent additives in the oil will make fresh oil look dark after the engine has been running for a short time. This is normal and is not a reason to change the oil more often than recommended.


Because of the problem of proper disposal, along with the special tools and necessary expertise required, we strongly recommend that you have your oil changed by an authorized **Audi dealer** or a qualified service station.

If you choose to change your oil yourself, please note the following important information:

WARNING

To reduce the risk of personal injury if you must change the engine oil in your vehicle yourself:

- Wear eye protection.
- To reduce the risk of burns from hot engine oil, let the engine cool down to the touch.
- When removing the oil drain plug with your fingers, stay as far away as possible. Always keep your forearm parallel to the ground to help prevent hot oil from running down your arm.
- Drain the oil into a container designed for this purpose, one large enough to hold at least the total amount of oil in your engine.
- Engine oil is poisonous. Keep it well out of the reach of children. ▶

 **WARNING** (continued)

- **Continuous contact with used engine oil is harmful to your skin. Always protect your skin by washing oil off thoroughly with soap and water.**

 **Note**

Never mix oil additives with your engine oil. These additives can damage your engine and adversely affect your Audi Limited New Vehicle Warranty.

 **For the sake of the environment**

- Before changing your oil, first make sure you know where you can properly dispose of the used oil.
- Always dispose of used engine oil properly. Do not dump it on garden soil, wooded areas, into open streams or down sewage drains.
- Recycle used engine oil by taking it to a used engine oil collection facility in your area, or contact a service station. ■

Engine cooling system

Coolant

The engine coolant performs two functions: it keeps the engine from overheating and it protects the engine from freezing in the winter.

The cooling system is sealed and generally requires little attention. The cooling system has been filled at the factory with a permanent coolant which does not need to be changed. The coolant consists of a mixture of water and the manufacturer's glycol-based coolant additive G12++ antifreeze with anticorrosion additives (50% for USA

models; 60% for Canadian models). This mixture both assures the necessary frost protection and protects metal components in the engine's cooling system from corrosion and scaling. It also raises the boiling point of the coolant.


Do not reduce the concentration of the coolant in the summer by adding plain water. **The proportion of coolant additive must be at least 50% but not more than 60%** to maintain antifreeze protection and cooling efficiency. If the coolant frost protection is too low, the coolant could freeze and damage the vehicle heating and engine cooling system.

For year-round driving, antifreeze is added at the factory for temperatures down to:

- - 31 °F (- 35 °C) USA
- - 40 °F (- 40 °C) Canada.

You can mix the G12++ coolant additive with other additives (G12+ or G12). Always check with your authorized Audi dealer.

 **WARNING**

Before you check anything in the engine compartment, always read and heed all WARNINGS ⇒  in "Working in the engine compartment" on page 259.

 **Note**

- Before winter sets in, have the coolant checked to see if the coolant additive in your vehicle is sufficient to meet the climate conditions. This is especially important if you live in a region where the winter is extremely cold. If necessary, increase the proportion of coolant additive to 60%.
- When adding coolant additive to your cooling system, remember:
 - We recommend using only coolant additive G12++ (check the label) for your vehicle. This coolant additive is available at authorized Audi dealers. Other types of antifreeze can significantly

reduce corrosion protection. The resulting corrosion can cause a loss of coolant and serious engine damage.

- Do not add any type of radiator leak sealant to your vehicle's engine coolant. Adding radiator repair fluid may adversely affect the function and performance of your cooling system and could result in damage not covered by your New Vehicle Limited Warranty. ■

Checking the engine coolant level

The engine coolant level can be checked with a quick glance.

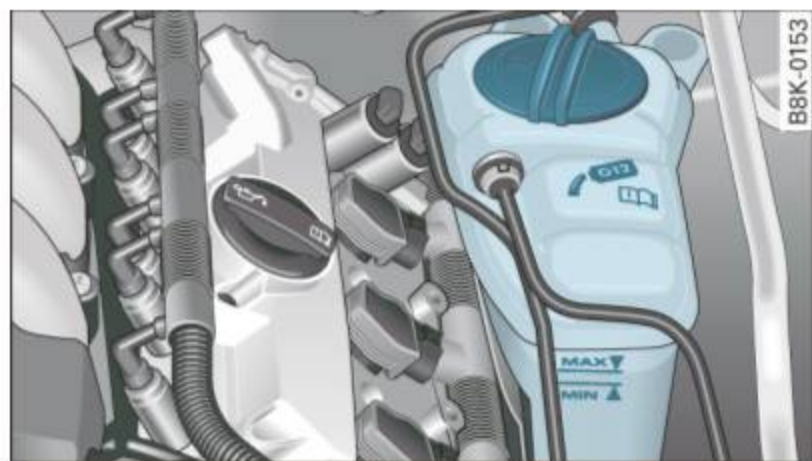


Fig. 206 Engine compartment: Coolant expansion tank

Before you check anything in the engine compartment, **always read and heed all WARNINGS** ⇒ ⚠ in "Working in the engine compartment" on page 259.

- Turn off the ignition.
- Let the engine cool down.
- Place a thick rag over the coolant expansion tank ⇒ fig. 206 and **carefully** twist the cap counter-clockwise ⇒ ⚠.

- Read the engine coolant level in the open coolant expansion tank ⇒ fig. 206. With a cold engine, the coolant level should be between the "min" and "max" markings. When the engine is warm, the level may be slightly above the "max" marking.

The location of the coolant expansion tank can be seen in the engine compartment illustration ⇒ page 260.

To obtain an accurate reading, the engine must be switched off.

The expansion tank in your vehicle is equipped with an electric coolant level sensor.

When the coolant level is too low, the warning light in the Auto-Check System ⇒ page 34 will blink until you add coolant and the level has been restored to normal. Even though there is an electric coolant level sensor, we still recommend you check the coolant level from time to time.

Coolant loss

Coolant loss may indicate a **leak** in the cooling system. In the event of coolant loss, the cooling system should be inspected immediately by your authorized Audi dealer. It is not enough merely to add coolant.

In a **sealed** system, losses can occur only if the boiling point of the coolant is exceeded as a result of overheating.

⚠ WARNING

The cooling system is under pressure and can get very hot. Reduce the risk of scalding from hot coolant by following these steps.

- Turn off the engine and allow it to cool down.
- Protect your face, hands and arms from escaping fluid and steam by covering the cap with a large, thick rag.

⚠ WARNING (continued)

- Turn the cap slowly and very carefully in a counter-clockwise direction while applying light, downward pressure on the top of the cap.
- To avoid being burned, do not spill antifreeze or coolant on the exhaust system or hot engine parts. Under certain conditions, the ethylene glycol in engine coolant can catch fire.

! Note

Do not add any type of radiator leak sealant to your vehicle's engine coolant. Adding radiator repair fluid may adversely affect the function and performance of your cooling system and could result in damage not covered by your New Vehicle Limited Warranty. ■

Adding coolant

Be very careful when adding engine coolant.

Before you check anything in the engine compartment, **always read and heed all WARNINGS** ⇒ **⚠** in "Working in the engine compartment" on *page 259*.

- Turn off the engine.
- Let the engine cool down.
- Place a thick rag over the coolant expansion tank ⇒ *page 267*, fig. 206 and **carefully** turn the cap counter-clockwise ⇒ **⚠**.
- Add coolant.
- Twist the cap on again *tightly*.

Replacement engine coolant must conform to exact specifications ⇒ *page 266*, "Coolant". Even in an emergency, if coolant additive

G12++, G12+ or G12 is **not** available, do **not** use a different additive. Use plain water instead until you can get the correct additive and can restore the correct ratio. This should be done as soon as possible.

If you have lost a considerable amount of coolant, then you should add cold antifreeze and cold water only when the engine is cold.

Always use *new* engine coolant when refilling.

Do not fill coolant above the "MAX" mark. Excess coolant will be forced out through the pressure relief valve in the cap when the engine becomes hot.

⚠ WARNING

- **The cooling system is under pressure and can get very hot. Reduce the risk of scalding from hot coolant by following these steps.**
 - Turn off the engine and allow it to cool down.
 - Protect your face, hands and arms from escaping fluid and steam by covering the cap with a large, thick rag.
 - Turn the cap slowly and very carefully in a counter-clockwise direction while applying light, downward pressure on the top of the cap.
 - To avoid being burned, do not spill antifreeze or coolant on the exhaust system or hot engine parts. Under certain conditions, the ethylene glycol in engine coolant can catch fire.
- Antifreeze is poisonous. Always store antifreeze in its original container and well out of the reach of children.
- If you drain the coolant, it must be caught and safely stored in a proper container clearly marked "poison".

! Note

- Coolant pollutes the environment and could cause an engine fire. Excess coolant will be forced out through the pressure relief valve in the cap when the engine becomes hot.
- If, in an emergency, only water can be added, the correct ratio between water and antifreeze ⇒ *page 266* must be restored as soon as possible.

🌸 For the sake of the environment

Drained coolant should not be reused. Always dispose of used coolant while observing all environmental regulations. ■

Radiator fan

The radiator fan switches on automatically by itself.

The radiator fan is driven by the engine via the V-belt. The viscous clutch regulates the speed of the fan according to the temperature of the coolant.

An auxiliary electric radiator fan* switches on and off depending on coolant temperature and other vehicle operating conditions.

After you switch the engine off, the auxiliary fan can continue running for up to 10 minutes - even with the ignition off. It can even switch on again later by itself ⇒ ⚠, if

- the temperature of the engine coolant rises due to the heat build-up from the engine in the engine compartment, or
- the engine compartment heats up because the vehicle is parked in intense sunlight.

⚠ WARNING

- **To reduce the risk of personal injury never touch the radiator fan.**

⚠ WARNING (continued)

- **The auxiliary electric fan is temperature controlled and can switch on suddenly even when the engine is not running.**
- **The auxiliary radiator fan switches on automatically when the engine coolant reaches a certain temperature and will continue to run until the coolant temperature drops. ■**

Brake fluid

Checking brake fluid level

The brake fluid level can be checked with a quick glance.

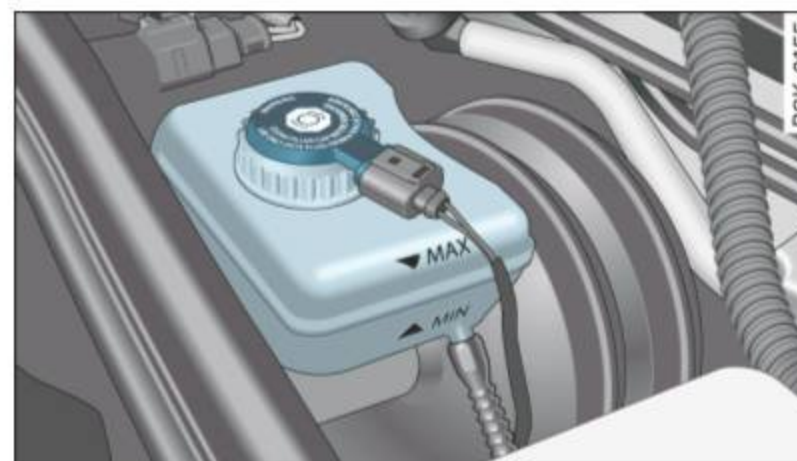



Fig. 207 Engine compartment: Brake fluid reservoir

Before you check anything in the engine compartment, **always read and heed all WARNINGS** ⇒ ⚠ in "Working in the engine compartment" on *page 259*.

- Read the brake fluid level from the brake fluid reservoir ⇒ fig. 207. The brake fluid level must be between the "MIN" and "MAX" markings.

The brake fluid reservoir is located at the rear partition of the engine compartment on the left side ⇒ *page 260*. ▶

The fluid level may drop *slightly* after some time due to the automatic adjustment of the brake pads. This is not cause for alarm.

If the brake fluid level falls *considerably* below the "MIN" mark, the brake warning/indicator light (U.S. models: **BRAKE**, Canadian models: ) will come on ⇒ *page 20* and ⇒ *page 33*. Do not continue to operate the vehicle. The complete brake system should be thoroughly checked by an authorized Audi dealer or qualified workshop and the cause corrected. If the brake fluid level is too low, the brake warning/indicator light will illuminate. Contact an authorized Audi dealer **immediately**.



Tips

The brake fluid reservoir is located underneath the cover. ■

Changing brake fluid

Have the brake fluid changed by an experienced technician.

Brake fluid absorbs moisture from the air. If the water content in the brake fluid is too high, corrosion in the brake system may result after a period of time. The boiling point of the brake fluid will also decrease considerably and decrease braking performance.

Therefore, the brake fluid must be changed **every two years**. Always use new brake fluid which conforms to Federal Motor Vehicle Standard "FMVSS 116 DOT 4".

The brake fluid reservoir can be difficult to reach, therefore, we recommend that you have the brake fluid changed by your authorized **Audi dealer**. Your dealer has the correct tools, the right brake fluid and the know-how to do this for you.



WARNING

- **Brake fluid is poisonous. It must be stored only in the closed original container out of the reach of children!**



WARNING (continued)

- **Brake failure can result from old or inappropriate brake fluid. Observe these precautions:**
 - **Use only brake fluid that meets SAE specification J 1703 and conforms to Federal Motor Vehicle Standard 116. Always check with your authorized Audi dealer to make sure you are using the correct brake fluid. The correct type of brake fluid is also indicated on the brake fluid reservoir.**
 - **The brake fluid must be new. Heavy use of the brakes can cause a vapor lock if the brake fluid is left in the system too long. This can seriously affect the efficiency of the brakes as well as your safety. This could result in an accident.**



Note

Brake fluid will damage the paint of your vehicle.



For the sake of the environment


Because of the problem of proper disposal of brake fluid as well as the special tools required and the necessary expertise, we recommend that you have the brake fluid changed by your authorized Audi dealer. ■

Battery

General information

Under **normal** operating conditions, the battery in your Audi does not need any maintenance. With *high* outside temperatures or long daily drives we recommend that you have the electrolyte level checked by an authorized Audi dealer or qualified workshop. The electrolyte level should also be checked each time the battery is charged ⇒ *page 273*.

Have the battery checked when you take your vehicle in for service. You are well advised to replace a battery that is older than 5 years.

With certain types of airbag deployment, the battery is disconnected from the vehicle electrical system for safety reasons ⇒  in "Repair, care and disposal of the airbags" on *page 186*.

Disconnecting the battery terminals

Some vehicle functions (power window regulators, for example) are lost if the battery terminals are disconnected. These functions have to be relearned after the battery terminals are connected again. To prevent this, the battery should only be disconnected from the vehicle electrical system when absolutely necessary for repairs.

Vehicles not driven for long periods

If you do not drive your vehicle over a period of several days or weeks, electrical components are gradually cut back or switched off. This reduces energy consumption and maintains starting capability over a longer period ⇒ *page 227*.

Take into consideration that when you unlock your vehicle, some convenience functions, such as the master key remote function or power seat adjustment, may not be available. The convenience functions will be available again when you turn on the ignition and start the engine.

Winter operation

During the winter months, battery capacity tends to decrease as temperatures drop. This is because more power is also consumed while starting, and the headlights, rear window defogger, etc., are used more often.


Avoid unnecessary power consumption, particularly in city traffic or when traveling only short distances. Let your authorized Audi dealer check the capacity of the vehicle battery before winter sets in ⇒ *page 273*. A well charged battery will not only prevent starting problems when the weather is cold, but will also last longer.

Tips

If your vehicle is left standing for several weeks at extremely low temperatures, the vehicle battery should be removed and stored where it will not freeze. This will prevent it from being damaged and having to be replaced. ■

Working on the battery

Be especially careful when working on or near the battery.

The battery is located in the luggage compartment under the floor. Before you check anything in the luggage compartment, **read and heed all WARNINGS** ⇒ .

Always heed the **safety warnings**, when working on the vehicle battery or the vehicle electrical system to prevent injury.

The following WARNINGS are very important when working on the battery:




Always heed the following WARNING SYMBOLS and safety precautions when working on the battery.



Always wear eye protection.



Battery acid contains sulfuric acid. Always wear gloves and eye protection.

	No - sparks - flames - smoking.
	When a battery is charged, it produces hydrogen gas which is explosive and could cause personal injury.
	Always keep the battery well out of reach of children.

WARNING

Whenever working on the battery or on the electrical system, there is the risk of injury, accident and even fire. Read and heed the following WARNINGS:

- Always wear eye protection. Do not let battery acid or any lead particles get on your skin or clothing. Shield your eyes. Explosive gases can cause blindness or other injury.
- Battery acid contains sulfuric acid. Sulfuric acid can cause blindness and severe burns.
 - Always wear gloves and eye protection. Do not tilt the battery because acid could leak out of the ventilation openings.
 - If you get battery acid in your eyes or on your skin, immediately rinse with cold water for several minutes and get medical attention.
 - If you should ingest any battery acid, seek medical attention immediately.
- Do not expose the battery to an open flame, electric sparks or an open light.
- Do not smoke.
- Do not interchange the positive and negative cables.
- When working on the battery, be sure not to short-circuit the terminals with tools or other metal objects. This would cause the

WARNING (continued)

battery to heat up very quickly, which could lead to damage or explosion and personal injury.

- When a battery is charged, it produces hydrogen gas which is explosive and could cause personal injury.
- Always keep the battery well out of the reach of children.
- Before work is done on the electrical system, disconnect the negative ground cable.
- Before performing any work on the electrical system, switch off the engine and ignition as well as any electrical equipment. The negative cable on the battery must be disconnected. If you are just going to replace a light bulb, then it is enough to switch off the lights.
- Before disconnecting the battery, switch off the anti-theft alarm system! Otherwise you will set off the alarm.
- When disconnecting the battery, first disconnect the negative cable and then the positive cable.
- Before reconnecting the battery, make sure all electrical consumers are switched off. Reconnect the positive cable first and then the negative cable. Never interchange the cables - this could start a fire!
- Never charge a frozen or a thawed-out battery. It could explode! If a battery has frozen, then it must be replaced. A discharged battery can freeze over at 32 °F (0 °C).
- Make sure the vent hose is always attached to the opening on the side of the battery.
- Never use batteries which are damaged. There is the danger of an explosion! Always replace a damaged battery.

WARNING

California Proposition 65 Warning:

⚠ WARNING (continued)

- **Battery posts, terminals and related accessories contain lead and lead compounds, chemicals known to the State of California to cause cancer and reproductive problems. Wash hands after handling.**

! Note

- Do not disconnect the vehicle battery when the ignition is switched on or when the engine is running, otherwise, you will damage electronic components in the electrical system.
- If your vehicle is going to stand for a long period of time without being driven, protect the battery from "freezing", otherwise it will be damaged and will then have to be replaced. ■

Battery charging

Starting the engine requires a well charged battery.

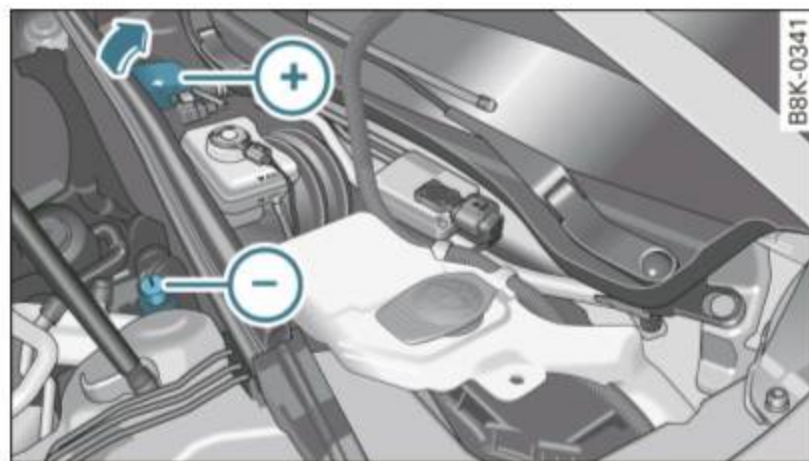


Fig. 208 Engine compartment: Connectors for charger and jumper cables

Always read and heed all WARNINGS below ⇒ ⚠ and ⇒ ⚠ in "Working on the battery" on *page 271*.

- Turn off the ignition and all electrical consumers.

- Make sure the area is well ventilated when you charge the battery.
- Open the engine hood ⇒ *page 258*.
- Open the red cover on the positive pole ⇒ *fig. 208*.
- Connect the charger connectors according to the instructions to the **jump start bolts**. (Bolts under the red cover = "positive", Bolts with hex head = "negative").
- Only now plug the mains lead for the charging equipment into the wall outlet and turn it on ⇒ ⚠.
- **Make sure the charging rate is not over 30 amps/14.8 Volt.**
- When the battery is fully charged: Turn the charging equipment off and remove the mains lead from the wall outlet.
- Now remove the clamps for the charging equipment.
- Close the red cover on the positive pole.
- Close the hood ⇒ *page 259*.

A discharged battery can **freeze** at temperatures of only 32 °F (0 °C). Allow a frozen battery to thaw completely before attempting to charge it ⇒ ⚠. However, we recommend not using a thawed battery again because the battery casing can be cracked due to ice formation and can leak battery acid.

Battery charging (Maximum charging rate of 30 amps/14.8 Volt)

When charging at *low* voltages (e.g. with a **trickle charger**), the battery cables do not have to be disconnected first. The battery caps should *not* be opened when charging a battery.

It is not necessary to remove the battery from the luggage compartment. ▶

Fast charging the battery (charging rate above 14.8 Volts)

For technical reasons do not use a battery charger that uses voltage greater than 14.8 Volts to charge your vehicle's battery.

WARNING

Charging a battery can be dangerous.

- **Always follow the operating instructions provided by the battery charger manufacturer when charging your battery.**
- **Never charge a frozen battery. It may explode because of gas trapped in the ice. Allow a frozen battery to thaw out first.**
- **Do not reuse batteries which were frozen. The battery housing may have cracked and weakened when the battery froze.**
- **Charge the battery in a well ventilated area. Keep away from open flame or electrical spark. Do not smoke. Hydrogen gas generated by the battery is explosive.**
- **To reduce the danger of explosion, never connect or disconnect charger cables while the charger is operating.**
- **Fast charging a battery is dangerous and should only be attempted by a competent technician with the proper equipment.**
- **Battery acid that may spill during charging should be washed off with a solution of warm water and baking soda to neutralize the acid.**

Note

Never use a fast charger as a booster to start the engine. This will seriously damage sensitive electronic components, such as control units, relays, radio, etc., as well as the battery charger. ■

Battery replacement

The new battery must have the same specifications and dimensions as the original equipment battery.

Intelligent energy management in your vehicle is responsible for distributing the electrical energy throughout your vehicle ⇒ page 227. The intelligent energy management system will keep the engine battery charged better than vehicles without this system. To make sure the additional electrical energy is available once again after you have changed the battery, we recommend that you install batteries of the same type and manufacture only (the same as those installed at the time your vehicle was delivered). Specifications are listed on the battery housing. Your authorized Audi dealer will then code the battery management control unit.

If it is not possible to use a battery of this type, the new battery must have the same capacity, voltage (12 volts), amperage, construction and plug sealing.

When installing the battery, make sure the ignition and all electrical consumers are turned off.

Note

Make sure the ventilation hose on the side of the battery is connected, otherwise fumes or battery acid can leak out.

For the sake of the environment

Because of the problem of proper disposal of a battery, we recommend your authorized Audi dealer change the battery for you. Batteries contain sulfuric acid and lead and must always be disposed of properly in compliance with all environmental regulations. Disposing of vehicle batteries improperly is very dangerous to the environment. ■

Windshield/headlight washer container

Using plain water is not adequate for filling the windshield washer system and the headlight washer system.

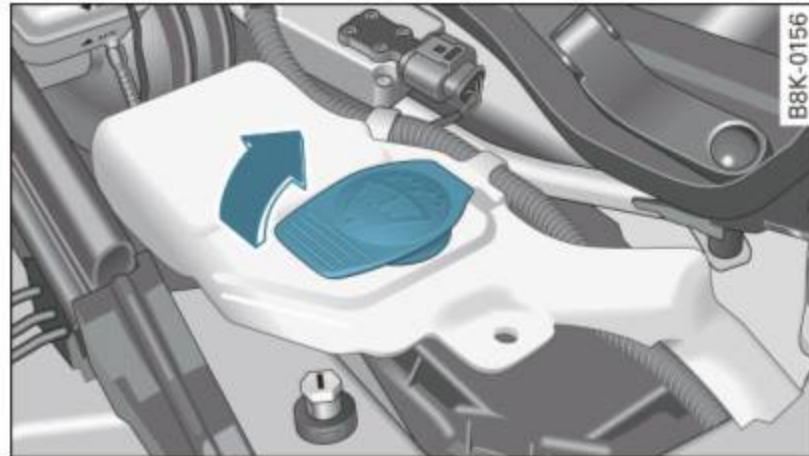




Fig. 209 Engine compartment: Windshield and headlight* washer fluid container

! Note

Do not mix engine coolant antifreeze or any other additives to fill up the windshield washer reservoir. ■

The washer fluid container is marked with the symbol  on its cap.

- Before you check anything in the engine compartment, **always read and heed all WARNINGS** ⇒  in “Working in the engine compartment” on *page 259*.
- Lift the filler cap tongue to add washer fluid. You can fill the container to the top.
- Press the cap back onto the filler neck after filling the container.

You can find the reservoir **capacity** in the table in ⇒ *page 329*.

Use winterized windshield washer solvent during the cold season even though the vehicle is equipped with **heated washer jets**. It helps to keep your windshield clean and prevents the fluid from freezing in the winter.

Follow the directions on the container for the correct amount to be used.

Tires and wheels

Tires

General notes

Tires may be the least appreciated and most abused parts of a motor vehicle.

Tires may be the least appreciated and most abused parts of a motor vehicle. Tires are, however, one of the most important parts of a vehicle, particularly considering the comparatively small patch of rubber on each tire that assures that all-important contact between you, your vehicle and the road.

Maintaining the correct tire pressure, making sure that your vehicle and its tires do not have to carry more weight than they can safely handle, avoiding damage from road hazards and regularly inspecting tires for damage including cuts, slashes irregular wear and overall condition are the most important things that you can do to help avoid sudden tire failure including tread separation and blowouts.

Avoiding damage

If you have to drive over a curb or similar obstacle, drive very slowly and as close as possible at a right angle to the curb.

Always keep chemicals including grease, oil, gasoline and brake fluid off the tires.

Inspect the tires regularly for damage (cuts, cracks or blisters, etc.). Remove any foreign bodies embedded in the treads.


Storing tires

Mark tires when you remove them to indicate the direction of rotation. This ensures you to be able to mount them correctly when you reinstall them.

When removed, the wheels or tires should be stored in a cool, dry and preferably dark place.

Store tires in a vertical position if they are not mounted on rims, in a horizontal position if they are mounted on rims.

New tires

New tires have to be broken in ⇒ .

The tread depth of new tires may vary, according to the type and make of tire and the tread pattern.

Hidden damage

Damage to tires and rims is often not readily visible. If you notice unusual vibration or the vehicle pulls to one side, this may indicate that one of the tires has been damaged. The tires must be checked immediately by an authorized Audi dealer or qualified workshop.

Unidirectional tires

A unidirectional tire can be identified by arrows on the sidewall, that point in the direction the tire is designed to rotate. You must follow the specified direction of rotation. This is necessary so that these tires can develop their optimum characteristics regarding grip, road noise, wear and hydroplaning resistance. For more information ⇒ *page 310*.

WARNING

New tires or tires that are old, worn or damaged cannot provide maximum control and braking ability.

- **New tires tend to be slippery and must be broken in. To reduce the risk of losing control, a collision and serious personal injuries, drive with special care for the first 350 miles (560 km).**
- **Driving with worn or damaged tires can lead to loss of control, sudden tire failure, including a blowout and sudden deflation,**

⚠ WARNING (continued)

crashes and serious personal injuries. Have worn or damaged tires replaced immediately.

- Tires age even if they are not being used and can fail suddenly, especially at high speeds. Tires that are more than 6 years old can only be used in an emergency and then with special care and at low speed.

⚠ WARNING (continued)

- Never mount used tires on your vehicle if you are not sure of their “previous history.” Old used tires may have been damaged even though the damage cannot be seen that can lead to sudden tire failure and loss of vehicle control.
- If you notice unusual vibration or if the vehicle pulls to one side when driving, always stop as soon as it is safe to do so and check the wheels and tires for damage. ■

Glossary of tire and loading terminology

Accessory weight

means the combined weight (in excess of those standard items which may be replaced) of automatic transmission, power steering, power brakes, power windows, power seats, radio, and heater, to the extent that these items are available as factory-installed equipment (whether installed or not).

Aspect ratio

means the ratio of the height to the width of the tire in percent. Numbers of 55 or lower indicate a low sidewall for improved steering response and better overall handling on dry pavement.

Bead

means the part of the tire that is made of steel wires, wrapped or reinforced by ply cords and that is shaped to fit the rim.

Bead separation

means a breakdown of the bond between components in the bead.

Cord

means the strands forming the plies in the tire.

Cold tire inflation pressure

means the tire pressure recommended by the vehicle manufacturer for a tire of a designated size that has not been driven for more than a couple of miles (kilometers) at low speeds in the three hour period before the tire pressure is measured or adjusted.

Curb weight

means the weight of a motor vehicle with standard equipment including the maximum capacity of fuel, oil, and coolant, air conditioning and additional weight of optional equipment.

Extra load tire

means a tire design to operate at higher loads and at higher inflation pressures than the corresponding standard tire. Extra load tires may be identified as “XL”, “xl”, “EXTRA LOAD”, or “RF” on the sidewall.

Gross Axle Weight Rating (“GAWR”)

means the load-carrying capacity of a single axle system, measured at the tire-ground interfaces.

Gross Vehicle Weight Rating (“GVWR”)

means the maximum total loaded weight of the vehicle. ▶

Groove

means the space between two adjacent tread ribs.

Load rating (code)

means the maximum load that a tire is rated to carry for a given inflation pressure. You may not find this information on all tires because it is not required by law.

Maximum load rating

means the load rating for a tire at the maximum permissible inflation pressure for that tire.

Maximum loaded vehicle weight

means the sum of:

- (a) Curb weight
- (b) Accessory weight
- (c) Vehicle capacity weight, and
- (d) Production options weight

Maximum (permissible) inflation pressure

means the maximum cold inflation pressure to which a tire may be inflated. Also called "maximum inflation pressure."

Normal occupant weight

means 150 lbs. (68 kilograms) times the number of occupants seated in the vehicle up to the total seating capacity of your vehicle.

Occupant distribution

means distribution of occupants in a vehicle.

Outer diameter

means the overall diameter of an inflated new tire.

Overall width

means the linear distance between the exteriors of the sidewalls of an inflated tire, including elevations due to labeling, decorations, or protective bands or ribs.

Ply

means a layer of rubber-coated parallel cords.

Production options weight

means the combined weight of those installed regular production options weighing over 5 lbs. (2.3 kg) in excess of those standard items which they replace, not previously considered in curb weight or accessory weight, including heavy duty brakes, ride levelers, roof rack, heavy duty battery, and special trim.

Radial ply tire

means a pneumatic tire in which the ply cords that extend to the beads are laid at substantially 90 degrees to the centerline of the tread.

Recommended inflation pressure

see ⇒ *page 277*, "Cold tire inflation pressure".

Reinforced tire

means a tire design to operate at higher loads and at higher inflation pressures than the corresponding standard tire. Reinforced tires may be identified as "XL", "xl", "EXTRA LOAD", or "RF" on the sidewall.

Rim

means a metal support for a tire or a tire and tube assembly upon which the tire beads are seated.

Rim diameter

means nominal diameter of the bead seat. If you change your wheel size, you will have to purchase new tires to match the new rim diameter.

Rim size designation

means rim diameter and width.

Rim width

means nominal distance between rim flanges.



Sidewall

means that portion of a tire between the tread and bead.

Speed rating (letter code)

means the speed at which a tire is designed to be driven for extended periods of time. The ratings range from 93 mph (150 km/h) to 186 mph (298 km/h) ⇒ *page 289*. You may not find this information on all tires because it is not required by law.

The speed rating letter code, where applicable, is molded on the tire sidewall and indicates the maximum permissible road speeds ⇒ ⚠ in “Winter tires” on *page 292*.

Tire pressure monitoring system

means a system that detects when one or more of a vehicle's tires are underinflated and illuminates a low tire pressure warning tell-tale.

Tread

means that portion of a tire that comes into contact with the road.

Tread separation

means pulling away of the tread from the tire carcass.

Treadwear indicators (TWI)

means the projections within the principal grooves designed to give a visual indication of the degrees of wear of the tread. See ⇒ *page 286*, “Tread Wear Indicator (TWI)” for more information on measuring tire wear.

Uniform Tire Quality Grading

is a tire information system developed by the United States National Highway Traffic Safety Administration (NHTSA) that is designed to help buyers make relative comparisons among tires. The UTQG is not a safety rating and not a guarantee that a tire will last for a prescribed number of miles (kilometers) or perform in a certain way. It simply gives tire buyers additional information to combine with other considerations, such as price, brand loyalty and dealer recom-

mendations. Under UTQG, tires are graded by the tire manufacturers in three areas: treadwear, traction, and temperature resistance. The UTQG information on the tires, molded into the sidewalls.

U.S. DOT Tire Identification Number (TIN)

This is the tire's “serial number”. It begins with the letters “DOT” and indicates that the tire meets all federal standards. The next two numbers or letters indicate the plant where it was manufactured, and the last four numbers represent the week and year of manufacture. For example,

DOT ... 2205 ...

means that the tire was produced in the 22th week of 2005. The other numbers are marketing codes that may or may not be used by the tire manufacturer. This information is used to contact consumers if a tire defect requires a recall.

Vehicle capacity weight

means the rated cargo and luggage load plus 150 lbs. (68 kilograms) times the vehicle's total seating capacity as listed on the label located either on the driver's side B-pillar or on the inside of the fuel filler flap.

Vehicle maximum load on the tire

means that load on an individual tire that is determined by distributing to each axle its share of the maximum loaded vehicle weight and dividing by two.

Vehicle normal load on the tire

means that load on an individual tire that is determined by distributing to each axle its share of the curb weight, accessory weight, and normal occupant weight (distributed in accordance with table below ⇒ *page 280*) and dividing by two. ▶

Occupant loading and distribution for vehicle normal load for various designated seating capacities

Designated seating capacity, number of occupants	Vehicle normal load, number of occupants	Occupant distribution in a normally loaded vehicle
4	2	2 in front

Cold tire inflation pressure

Tire pressure affects the overall handling, performance and safety of a vehicle.



Fig. 210 Tire pressure label: located either on driver's side B-pillar or inside the fuel filler flap

Tire pressure generally refers to the amount of air in a tire that it needs it to do its job and safely carry the combined load of the entire vehicle and its contents. Tire pressure is measured in kilopascals (kPa), the international measuring unit and in pounds per square inch (PSI). Tire pressure is based in part on the vehicle's design and load limit – the greatest amount of weight that the vehicle can carry safely and the tire size. The proper tire pressure is frequently referred to as the “recommended cold tire inflation pressure.” Air in the tires expands when the tire heats up because of internal friction when it flexes in use. The tire pressure is higher when the tire has warmed up than when it is “cold.” It is the inflation pressure in a “cold” tire that counts. Therefore, you should never let air out of a warm tire to match “cold tire inflation pressure” recommendations. The tires would then be underinflated and could fail suddenly.

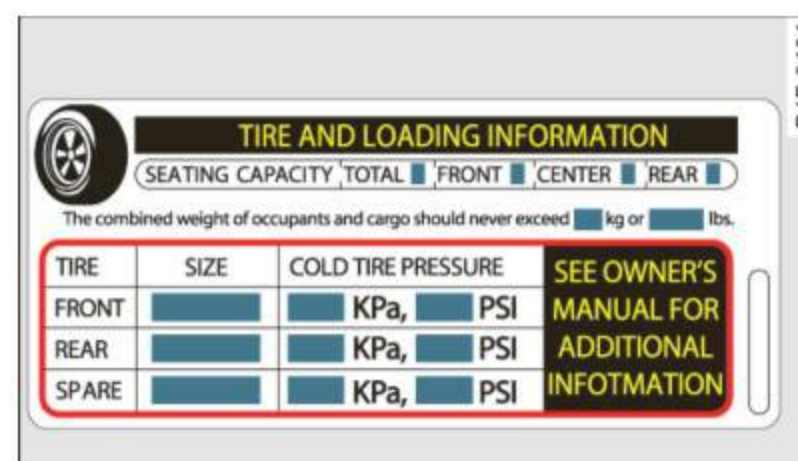


Fig. 211 Tire pressure label

Maintaining proper tire pressure is one of the most important things you can do to help avoid sudden tire failure. Underinflated tires are a major cause of sudden tire failure. Keeping tires at the right pressure is also important for safe and responsive vehicle handling, traction, braking and load carrying. **Tire pressures are particularly important when the vehicle is being driven at higher speeds, and then especially when heavily loaded even within the permissible load-carrying capacities approved for your vehicle.**

The recommended tire pressures for your Audi depend on the kind of tires on your vehicle and the number of passengers and/or amount of luggage you will be transporting.

On USA vehicles, the tire pressure label is located on the driver's side B-pillar. On Canada vehicles, the tire pressure label is located either on the driver's side B-pillar or inside the fuel filler flap. The tire pressure label lists the recommended cold tire inflation pressures

for the vehicle at its maximum capacity weight and tires that were on your vehicle at the time it was manufactured.

If you wish to improve comfort when operating the vehicle at normal load (up to 3 occupants), you can adjust tire pressures to those specified for normal vehicle load. Before operating the vehicle at maximum load, you must increase the tire pressures to those specified for maximum vehicle load ⇒ ⚠.

Bear in mind that the tire pressure monitoring system can only monitor the tire pressures you have stored. The system does not recognize the load condition of your vehicle.

The effectiveness of the tire pressure monitoring system will be impaired if you store normal load pressures but then operate the vehicle at its maximum load ⇒ ⚠.

See the illustration ⇒ *page 280*, fig. 210 for the location of the label either on driver's side B-pillar or inside the fuel filler flap (color of the actual label and exact location on the vehicle will vary slightly).

Note that the following table is accurate at the time of going to press and is subject to change. In the event of discrepancies, the tire pressure label (On USA vehicles, the tire pressure label is located on the driver's side B-pillar. On Canada vehicles, the tire pressure label is located either on the driver's side B-pillar or inside the fuel filler flap) always takes precedence.

The table below lists the recommended cold tire inflation pressures for the Audi model covered by your Owner's Literature at the vehicle's capacity weight and the tire sizes installed on the respective models as original equipment, or as a factory option.

Engine (displacement in liter)	Tire designation	Tire pressure front				Tire pressure rear			
		normal load condition (up to 2 occupants)		full load condition		normal load condition (up to 2 occupants)		full load condition	
		PSI	kPA	PSI	kPA	PSI	kPA	PSI	kPA
6-cylinder 3.2	245/45 R17 95 H	35	240	35	240	29	200	33	230
	245/40 R18 97H	36	250	36	250	32	220	35	240
	255/35 R19 96H XL	36	250	36	250	32	220	35	240
	255/35 R19 96Y XL	33	230	33	230	32	220	32	220
	265/30 ZR20 94Y XL	38	260	41	280	33	230	41	280

XL = reinforced or extra load tire. It may also appear as xl, EXTRA LOAD, or RF on the tire sidewall.

The correct tire pressure for the *spare wheel* is located on a label either on the driver's side B-pillar or inside the fuel filler flap.

Because technical changes may be made to vehicle equipment during the model year, always compare the tire size designation on the tire pressure label on your vehicle with the tires on your vehicle. Make sure that the tire size information on the vehicle label is the

same as the size of the tires on the vehicle. This is especially important if the vehicle belongs to someone else or you bought the vehicle with different rims/tires or you bought the vehicle as a previously owned vehicle.

Remember, your safety and that of your passengers also depends on making sure that load limits are not exceeded. Vehicle load ►

includes everybody and everything in and on the vehicle. These load limits are technically referred to as the vehicle's Gross Vehicle Weight Rating ("GVWR"). The Gross Axle Weight Rating ("GAWR") is the maximum load that can be applied at each of the vehicle's two axles. The Gross Vehicle Weight Rating and the Gross Axle Weight Rating are listed on the safety compliance sticker label located either on the driver's side B-pillar or on the inside of the fuel filler flap. The tire pressure label on your Audi lists the maximum combined weight of all of the occupants and luggage or other cargo that the vehicle can carry. For the location of the tire pressure label ⇒ *page 280, fig. 210.*

WARNING

Overloading a vehicle can cause loss of vehicle control, a crash or other accident, serious personal injury, and even death.

- **Carrying more weight than your vehicle was designed to carry will prevent the vehicle from handling properly and increase the risk of a loss of vehicle control.**
- **The brakes on a vehicle that has been overloaded may not be able to stop the vehicle within a safe distance.**
- **Tires on a vehicle that has been overloaded can fail suddenly causing loss of control and a crash.**
- **Always make sure that the total load being transported – including the weight of a trailer hitch and the tongue weight of a loaded trailer – does not make the vehicle heavier than the vehicle's Gross Vehicle Weight Rating.**

WARNING

- **Incorrect tire pressures and/or underinflation can lead to a serious or fatal accident.**
- **Incorrect tire pressures and/or underinflation cause increased tire wear and can affect the handling of the vehicle.**

WARNING (continued)

- **Incorrect tire pressures and/or underinflation can also lead to sudden tire failure, including a blowout and sudden deflation, causing loss of vehicle control. ■**

Checking tire pressure

The correct tire pressure for the tires originally installed on your vehicle is listed on the tire pressure label located either on driver's side B-pillar or inside the fuel filler flap.

The recommended tire pressures are on the tire pressure label and in the table ⇒ *page 280, "Cold tire inflation pressure"*. This means that the pressure must be checked and adjusted when the tire has not been driven for more than a couple of miles (kilometers) at low speeds during the previous three hours. Air in the tires expands when the tire heats up as a result of internal friction as it flexes in use. The tire pressure is higher when the tire has warmed up than when it is "cold."

It is the inflation pressure in a "cold" tire that counts. Therefore, you should never let air out of a warm tire to match "Cold tire inflation pressure" recommendations ⇒ *page 280*. The tires would then be underinflated and could fail suddenly.

The tire pressure label on your Audi lists the recommended cold tire inflation pressures at maximum capacity for the new, original equipment tires that were on your vehicle at the time it was manufactured. For the location of the label ⇒ *page 280, fig. 210.*

Most tires lose air naturally over time. They can also lose some air if you drive over a pothole or hit a curb while parking. It is usually not possible to see whether the radial tires used today are underinflated just by looking at them.

Therefore, be sure to check tire pressures at least once a month and always before going on a long trip. Make sure to take the number of people and the amount of luggage into account when adjusting tire ►

pressure for a trip – even one that you would not consider to be “long.” See ⇒ *page 284*, “Tires and vehicle load limits” for more important information.

Always use an accurate tire pressure gauge when checking and adjusting inflation pressures. Check all of the tires and be sure not to forget the spare tire. If the pressure in any tire is too high when the tire is “cold,” let air out of the tire slowly with the edge of the tire gauge and keep checking the pressure until you reach the pressure that is correct for the load (passengers and luggage) and kind of driving you plan to do.

If the pressure in any tire is too low, note the difference between the pressure in the cold tire and the pressure you need and add the air that you need to reach the correct pressure for the vehicle load (passengers and luggage) for the tires on your vehicle as listed on the on your vehicle and in this manual and the kind of driving you plan to do.

Never exceed the maximum inflation pressure listed on the tire sidewall for any reason.

Remember that the vehicle manufacturer, not the tire manufacturer, determines the correct tire pressure for the tires on your vehicle.

It is important to check the tire pressure when the tires are cold.

- Read the required tire pressure from the tire pressure label. On USA vehicles, the tire pressure label is located on the driver's side B-pillar. On Canada vehicles, the tire pressure label is located either on the driver's side B-pillar or inside the fuel filler flap. The tire pressure label lists the recommended cold tire inflation pressures for the vehicle at its maximum capacity weight and the tires that were on your vehicle at the time it was manufactured. For recommended tire pressures for normal load conditions, please see chapter ⇒ *page 280*.
- Turn the valve stem cap counter-clockwise to remove it from the tire valve.
- Place the air pressure gauge on the valve.

- The tire pressures should only be checked and adjusted when the tires are cold. The slightly raised pressures of warm tires must not be reduced.
- Adjust the tire pressure to the load you are carrying.
- Reinstall the valve stem cap on the valve.

When should I check the tire pressure?


The correct tire pressure is especially important at high speeds. The pressure should therefore be checked at least once a month and always before starting a journey. Do not forget to check the tire pressure for the spare wheel.


When should I adjust the tire pressures?

Adjust the tire pressure to the load you are carrying. After changing a wheel **or** replacing wheels you have to adjust the tire pressures on all wheels. In addition, you must then initialize the new tire pressures in the tire pressure monitoring system ⇒ *page 40*.

WARNING

Incorrect tire pressures and/or underinflation can lead sudden tire failure, loss of control, collision, serious personal injury or even death.

- **When the warning symbol  appears in the instrument cluster, stop and inspect the tires.**
- **Incorrect tire pressure and/or underinflation can cause increased tire wear and can affect the handling of the vehicle and stopping ability.**
- **Incorrect tire pressures and/or underinflation can also lead to sudden tire failure, including a blowout and sudden deflation, causing loss of vehicle control.**
- **The driver is responsible for the correct tire pressures for all tires on the vehicle. The applicable pressure values are located on a sticker on the driver's side B-pillar or on the inside of the fuel filler flap.**

 **WARNING** (continued)

- **Only when all tires on the vehicle are filled to the correct pressure, the tire pressure monitoring system can work correctly.**
- **The use of incorrect tire pressure values can lead to accidents or other damage. Therefore it is essential that the driver observe the specified tire pressure values for the tires and the correct pressures for the function of the tire pressure monitoring system.**
- **Always inflate tires to the recommended and correct tire pressure before driving off.**
- **Driving with underinflated tires bend more, letting them get too hot resulting in tread separation, sudden tire failure and loss of control.**
- **Excessive speed and/overloading can cause heat build-up, sudden tire failure and loss of control.**
- **If the tire pressure is too low or too high, the tires will wear prematurely and the vehicle will not handle well.**
- **If the tire is not flat and you do not have to change a wheel immediately, drive at reduced speed to the nearest service station to check the tire pressure and add air as required.**

 **Note**

Driving without valve stem caps can cause damage to the tire valves. To prevent this, always make sure that factory installed valve stem caps on all wheels are securely mounted on the valve.

 **For the sake of the environment**

Underinflated tires will also increase the fuel consumption. ■

Tires and vehicle load limits

There are limits to the amount of load or weight that any vehicle and any tire can carry. A vehicle that is overloaded will not handle well

and is more difficult to stop. Overloading can not only lead to loss of vehicle control, but can also damage important parts of the vehicle and can lead to sudden tire failure, including a blowout and sudden deflation that can cause the vehicle to crash.

Your safety and that of your passengers also depends on making sure that load limits are not exceeded. Vehicle load includes everybody and everything in and on the vehicle. These load limits are technically referred to as the vehicle's **Gross Vehicle Weight Rating** ("GVWR").

The "GVWR" includes the weight of the basic vehicle, all factory installed accessories, a full tank of fuel, oil, coolant and other fluids plus maximum load. The maximum load includes the number of passengers that the vehicle is intended to carry ("seating capacity") with an assumed weight of 150 lbs (68 kg) for each passenger at a designated seating position and the total weight of any luggage in the vehicle. If you tow a trailer, the weight of the trailer hitch and the tongue weight of the loaded trailer must be included as part of the vehicle load.

The **Gross Axle Weight Rating** ("GAWR") is the maximum load that can be applied at each of the vehicle's two axles.

The Gross Vehicle Weight Rating and the Gross Axle Weight Rating are listed on the safety compliance sticker label located either on the driver's side B-pillar or on the inside of the fuel filler flap. Your Audi has 4 seating positions, 2 in the front and 2 in the rear for total seating capacity of 4. Each seating position has a seat belt ⇒ *page 163, "Safety belts"*.

The fact that there is an upper limit to your vehicle's Gross Vehicle Weight Rating means that the total weight of whatever is being carried in the vehicle (including the weight of a trailer hitch and the tongue weight of the loaded trailer) is limited. The more passengers in the vehicle or passengers who are heavier than the standard weights assumed mean that less weight can be carried as luggage.

The tire pressure label on your Audi also lists the maximum combined weight of all of the occupants and luggage or other cargo ►

that the vehicle can carry. For the location of the label ⇒ *page 280*, fig. 210.

WARNING

Overloading a vehicle can cause loss of vehicle control, a crash or other accident, serious personal injury, and even death.

- Carrying more weight than your vehicle was designed to carry will prevent the vehicle from handling properly and increase the risk of the loss of vehicle control.
- The brakes on a vehicle that has been overloaded may not be able to stop the vehicle within a safe distance.
- Tires on a vehicle that has been overloaded can fail suddenly, including a blowout and sudden deflation, causing loss of control and a crash.
- Always make sure that the total load being transported – including the weight of a trailer hitch and the tongue weight of a loaded trailer – does not make the vehicle heavier than the vehicle's Gross Vehicle Weight Rating. ■

Determining correct load limit

Use the example below to calculate the total weight of the passengers and luggage or other things that you plan to transport so that you can make sure that your vehicle will not be overloaded.

Steps for Determining Correct Load Limit

1. Locate the statement "THE COMBINED WEIGHT OF OCCUPANTS AND CARGO SHOULD NEVER EXCEED XXX KG OR XXX LBS" on your vehicle's placard (tire inflation pressure label) ⇒ *page 280*, fig. 210.
2. Determine the combined weight of the driver and passengers that will be riding in your vehicle.
3. Subtract the combined weight of the driver and passengers from "XXX" kilograms or "XXX" pounds shown on the sticker ⇒ *page 280*, fig. 210.
4. The resulting figure equals the available amount of cargo and luggage load capacity. For example, if the "XXX" amount equals 1400 lbs. and there will be five 150 lbs. passengers in your vehicle, the amount of available cargo and luggage load capacity is 650 lbs. (1400-750 (5 x 150) = 650 lbs.)

5. Determine the combined weight of luggage and cargo being loaded on the vehicle. That weight may not safely exceed the available cargo and luggage load capacity calculated in Step 4.
6. If your vehicle will be towing a trailer, load from your trailer will be transferred to your vehicle. Consult this manual to determine how this reduces the available cargo and luggage load capacity of your vehicle.
 - Check the tire sidewall (\Rightarrow *page 288*, fig. 214) to determine the designated load rating for a specific tire. ■

Tire service life

The service life of tires depends on a lot of different things including proper installation and balancing, correct tire pressure and driving style.

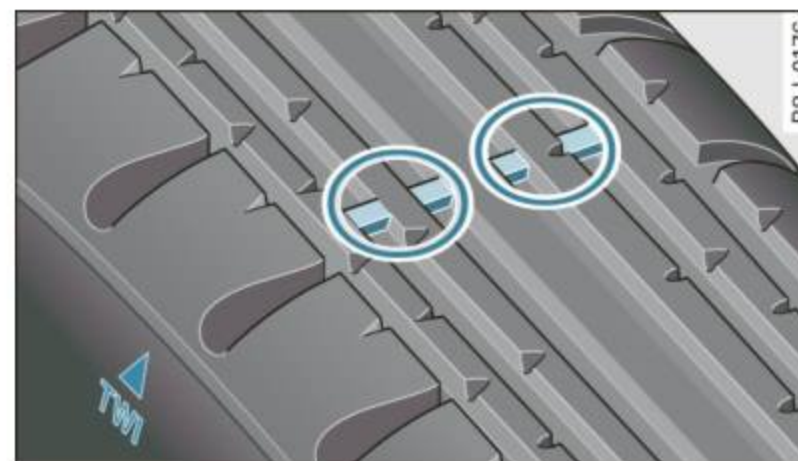


Fig. 212 Tire tread: tread wear indicators (TWI)

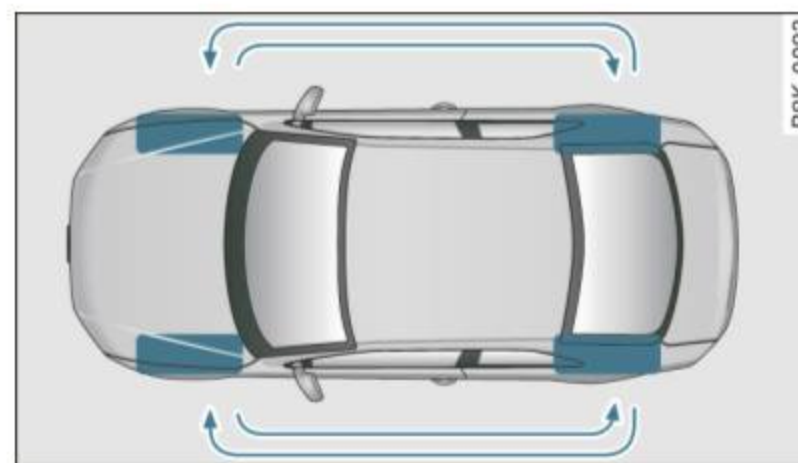


Fig. 213 Rotating tires for more even wear

Tread Wear Indicator (TWI)

The original tires on your vehicle have 1/16 inch (1.6 mm) high “wear indicators” \Rightarrow fig. 212 running across the tread. Depending on the make, there will be six to eight of them evenly placed around the tire. Marks on the tire sidewall (for example “TWI” or other symbols) indicate the positions of the tread wear indicators. Worn tires must be replaced. Different figures may apply in other countries \Rightarrow ⚠. ▶

Tire pressure

Incorrect tire pressure causes premature wear and can cause sudden tire blow-out. For this reason, tire pressure must be checked at least once a month ⇒ *page 282*.

Driving style

Driving fast around curves, heavy acceleration and hard braking increase tire wear.

Rotating tires for more even wear

For all four tires on your vehicle to have the same service life, we recommend that the front and rear tires are rotated according to the tire manufacturer's suggested tire rotation intervals. Please remember the following:

- Tire rotation intervals may differ from the vehicle service intervals outlined in your Maintenance and Warranty Booklet.
- The longer one tire is used in one location on the vehicle, the more it wears at certain points; therefore, we recommend that you follow the tire manufacturer's suggested tire rotation intervals.
- Vehicles with front-wheel drive experience more tread wear on the front wheels compared to all-wheel drive (quattro®).
- Please rotate tires as shown ⇒ *page 286*, fig. 213.
- Extra care must be taken when rotating direction-specific tires ⇒ *page 310*.

Wheel balancing

The wheels on new vehicles are balanced. However, various situations during everyday driving can cause them to become unbalanced, resulting in vibrations you can usually feel through the steering wheel.

Unbalanced wheels must be rebalanced to avoid excessive wear on steering, suspension and tires. A wheel must also be rebalanced when a new tire is installed.

Incorrect wheel alignment

Incorrect wheel alignment can cause excessive tire wear, impairing the safety of the vehicle. If tires show excessive wear, have the wheel alignment checked by an authorized Audi dealer or qualified workshop.

All wheel drive

Vehicles with quattro® must always have tires of the same size, construction and tread type. For details see ⇒ *page 226*.



WARNING

Sudden tire failure can lead to loss of control, a crash and serious personal injury!

- **Never drive a vehicle when the tread on any tire is worn down to the wear indicators.**
- **Worn tires are a safety hazard, they do not grip well on wet roads and increase your risk of "hydroplaning" and loss of control.**
- **Always keep chemicals that can cause tire damage, such as grease, oil, gasoline and brake fluid away from tires.**
- **Tires age even if they are not being used and can fail suddenly, especially at high speeds. Tires that are more than 6 years old can only be used in an emergency and then with special care and at lower speeds.**
- **Never mount used tires on your vehicle if you are not sure of their "previous history." Old used tires may have been damaged even though the damage cannot be seen that can lead to sudden tire failure and loss of vehicle control. ■**

New tires and replacing tires and wheels

New tires and wheels have to be broken in.

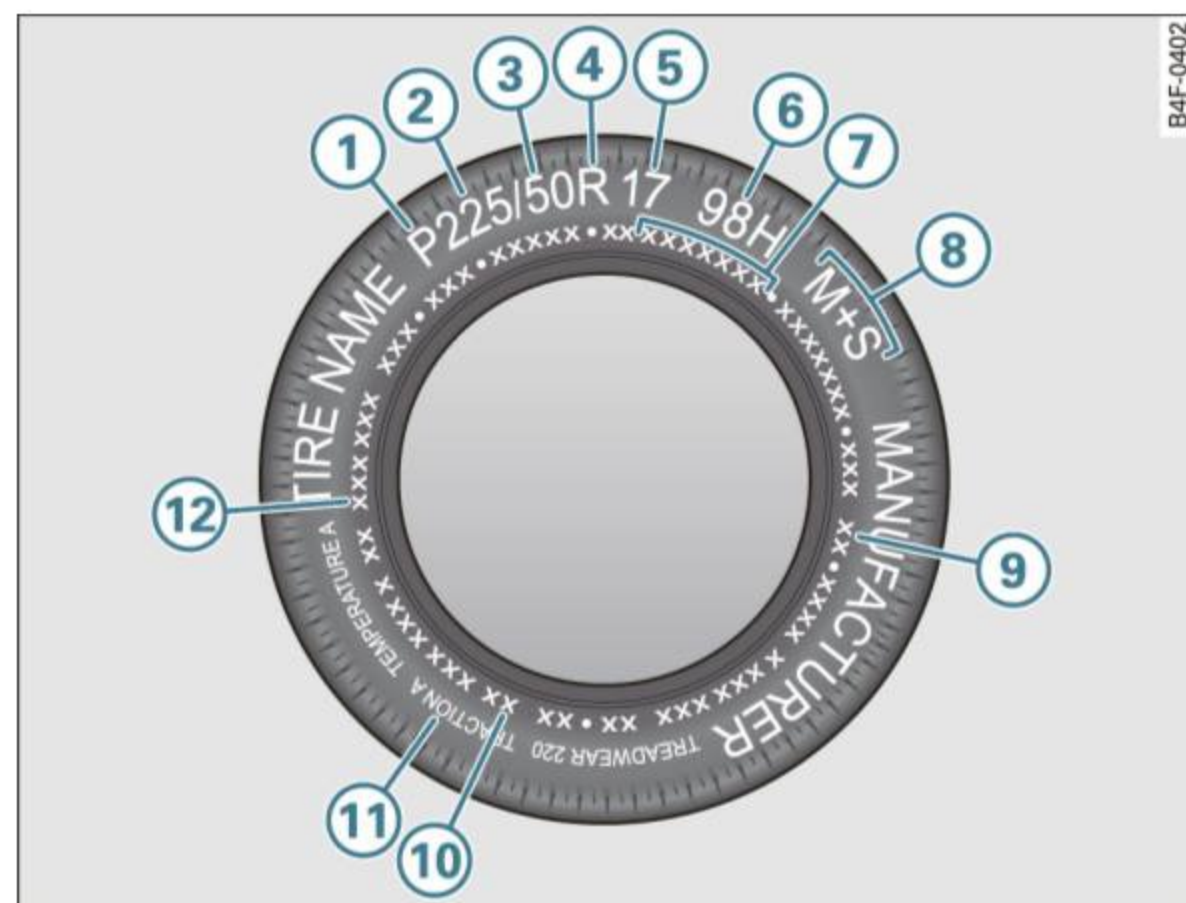


Fig. 214 Tire specification codes on the sidewall of a tire

No.	Description
①	Passenger car tire (where applicable)
②	Nominal width of tire in millimeters
③	Ratio of height to width (aspect ratio)
④	Radial
⑤	Rim diameter code
⑥	Load index and speed rating

⑦	U.S. DOT tire identification number
⑧	Sever snow conditions
⑨	Tire ply composition and materials used
⑩	Maximum load rating
⑪	Treadwear, traction and temperature grades
⑫	Maximum permissible inflation pressure

The tires and rims are essential parts of the vehicle's design. The tires and rims approved by Audi are specially matched to the characteristics of the vehicle and can make a major contribution to good road holding and safe handling when in good condition and properly inflated ⇒ ⚠.

We recommend that all work on tires and wheels be performed by an authorized Audi dealer. They are familiar with recommended procedures and have the necessary special tools and spare parts as well as the proper facilities for disposing of the old tires.

Authorized Audi dealers have the necessary information about technical requirements for installing or changing tires and rims.

Replacing tires and wheels

Tires should be replaced at least in pairs and not individually (for example both front tires or both rear tires together).

Be sure to read and heed the information to the tire pressure monitoring system ⇒ *page 290*.

Always buy replacement radial tires that have the same specifications as the tires approved for your vehicle by Audi. Replacement tires must always have the same load rating specification as the original equipment or approved optional tires listed in the table ⇒ *page 280*.

Audi-approved specification tires are specially matched to your vehicle and its load limits, and can contribute to the important road- ▶

holding, driving characteristics, and safety of the vehicle. The table (⇒ *page 280*) lists specifications of the tires approved for the Audi models covered by your Owner's Literature.

The tire pressure label (On USA vehicles, the tire pressure label is located on the driver's side B-pillar. On Canada vehicles, the tire pressure label is located either on the driver's side B-pillar or inside the fuel filler flap)(⇒ *page 280*, fig. 211) lists the specifications of the original equipment tires installed on your vehicle at the time it was manufactured.

Federal law requires tire manufacturers to place standardized information on the sidewall of all tires ⇒ *page 288*, fig. 214. This information identifies and describes the fundamental characteristics, the quality grade of the tire and also provides a tire identification number for safety standard certification and in case of a recall.

Tire specifications

Knowledge of tire specifications makes it easier to choose the correct tires. Radial tires have the tire specifications marked on the sidewall, for example:

P255 / 35 R19 96Y XL

This contains the following information:

- P** Indicates the tire is for passenger cars (where applicable)
- 255** Nominal tire width in mm of the tire from sidewall edge to sidewall edge. In general, the larger the number, the wider the tire
- 35** Height/width ratio in percent (aspect ratio)
- R** Tire construction: **Radial**
- 19** Rim diameter code (in inches)
- 96** Load rating code
- Y** Speed rating letter code
- XL** (or "xl", "EXTRA LOAD", or "RF" Indicates that the tire is a "Reinforced" or an "Extra Load" tire
- M+S** (or "M/S") Indicates that the tire has some mud and snow capability


The tires could also have the information of direction of rotation ⇒ *page 276*.

Tire manufacturing date


The manufacturing date is also indicated on the tire sidewall (possibly only on the *inner* side of the wheel):

"DOT ... 2207..." means, for example, that the tire was produced in the 22th week of 2007.

Speed rating (letter code)

The speed rating letter code on the wheels indicates the maximum permissible road speeds ⇒  in "Winter tires" on *page 292*.

- P** up to 93 mph (150 km/h)
- Q** up to 99 mph (158 km/h)
- R** up to 106 mph (170 km/h)
- S** up to 110 mph (180 km/h)
- T** up to 118 mph (190 km/h)
- U** up to 124 mph (200 km/h)
- H** up to 130 mph (210 km/h)
- V** up to 149 mph (240 km/h)²⁾
- Z** over 149 mph (240 km/h)²⁾
- W** up to 168 mph (270 km/h)²⁾
- Y** up to 186 mph (298 km/h)²⁾

Your vehicle is normally factory equipped with tires, which possess excellent driving characteristics and give your Audi optimum driving comfort. An electronic speed limiter ⇒ *page 27* will normally prevent your vehicle from going faster than the tire speed rating ⇒ .

²⁾ For tires with a maximum speed capability over 149 mph (240 km/h), tire manufacturers sometimes use the letters "ZR."

U.S. DOT Tire Identification Number (TIN) and tire manufacture date

This is the tire's "serial number". It begins with the letters "DOT" and indicates that the tire meets all federal standards. The next two numbers or letters indicate the plant where it was manufactured, and the last four numbers represent the week and year of manufacture. For example, the numbers 2207 mean that the tire was produced in the 22th week of 2007. The other numbers are marketing codes that may or may not be used by the tire manufacturer. This information is used to contact consumers if a tire defect requires a recall.

Tire ply composition and materials used

The number of plies indicates the number of layers of rubber-coated fabric in the tire. In general, the greater the number of plies, the more weight a tire can support. Tire manufacturers also must indicate the materials in the tire, which include steel, nylon, polyester, and others.

Maximum Load Rating

This number indicates the maximum load in kilograms and pounds that can be carried by the tire.

Tire quality grading for treadwear, traction, and temperature resistance

Tread wear, traction and temperature grades ⇒ *page 292*.

Maximum Permissible Inflation Pressure

This number is the greatest amount of air pressure that should ever be put in the tire under normal driving conditions.

Replacing tires or rims on vehicles equipped with tire pressure monitoring system

The wheels on your vehicle are equipped with a sensor which constantly monitors the air pressure inside the tire, and then transmits this information to the tire pressure monitoring system. If you are going to replace the wheel rims on your vehicle, make sure the

new rims also have these sensors. The sensors must be compatible with the tire pressure monitoring system on your vehicle.

If you install rims, which do not have the sensors, or have sensors which are not compatible, then the tire pressure monitoring system will not work properly. In this case, the tire pressure monitoring system would not be able to monitor the tire pressure or warn you if it is necessary.


- The battery inside of the tire pressure sensor has a limited service life.
- Always drive with the valve stem caps securely mounted. We recommend using factory installed valve stem caps. Ask your authorized Audi dealer to replace lost valve stem caps.

The installation of replacement tires with steel cord body plies in the tire sidewall may cause malfunction of the tire pressure monitoring system, and is not recommended (cord material information is molded on the tire sidewall).

Always check your tire pressure monitoring system indicator after replacing one or more tires on your vehicle. If the tire pressure monitoring system indicator flashes, or is on, your system is not working properly. Your replacement tire might be incompatible with your tire pressure monitoring system, or some component of the tire pressure monitoring system may be damaged.

WARNING

- **Using incorrect or unmatched tires and / or wheels or improper tire and wheel combinations can lead to loss of control, collision and serious personal injury.**
- **Always use tires, rims and wheel bolts that meet the specifications of original factory-installed tires or other combinations that have been specifically approved by the vehicle manufacturer.**
- **Tires age even if they are not being used and can fail suddenly, especially at high speeds. Tires that are more than 6 years old can only be used in an emergency and then with special care and at lower speeds.**

 WARNING (continued)

- Never mount used tires on your vehicle if you are not sure of their "previous history." Old used tires may have been damaged even though the damage cannot be seen that can lead to sudden tire failure and loss of vehicle control.
- All four wheels must be fitted with radial tires of the same type, size (rolling circumference) and the same tread pattern. Driving with different tires reduces vehicle handling and can lead to a loss of control.
- If the spare tire is not the same as the tires that are mounted on the vehicle - for example with winter tires - only use the spare tire for a short period of time and drive with extra care. Refit the normal road wheel as soon as safely possible.
- Never drive faster than the maximum speed for which the tires on your vehicle are rated because tires that are driven faster than their rated speed can fail suddenly.
- Overloading tires cause heat build-up, sudden tire failure, including a blowout and sudden deflation and loss of control.
- Temperature grades apply to tires that are properly inflated and not over or underinflated.
- For technical reasons it is not always possible to use wheels from other vehicles – in some cases not even wheels from the same vehicle model.
- If you install wheel trim discs on the vehicle wheels, make sure that the air flow to the brakes is not blocked. Reduced airflow to the brakes can them to overheat, increasing stopping distances and causing a collision.
- Run flat tires may only be used on vehicles that were equipped with them at the factory. The vehicle must have a chassis designed for run flat tires and a factory-installed tire pressure monitoring system that indicates a loss of tire pressure. Incorrect use of run flat tires can lead to vehicle damage or accidents. Check with an authorized Audi dealer or tire specialist to see if your vehicle can

 WARNING (continued)

be equipped with run flat tires. If run flat tires are used, they must be installed on all four wheels. Mixing tire types is not permitted.

 Note

- For technical reasons, it is not generally possible to use the wheel rims from other vehicles. This can hold true for wheels of the same vehicle type.
- If the spare tire is different from the tires that you have mounted on your vehicle (for example winter tires or wide profile tires), then use the spare tire for a short period of time only and drive with extra care. Replace the flat tire with the tire matching the others on your vehicle as soon as possible.
- If you should put different wheels and tires on your vehicle (e.g. winter wheels and tires), you must be certain that the wheels and tires are compatible with the tire pressure monitoring system. Otherwise the system will register a malfunction and a fault message will be displayed. For more information, contact your authorized Audi dealer.

 Note

- When installing new tires, be careful not to damage the valves or tire pressure monitoring system sensors.
- Never drive without the valve stem cap. The valves could get damaged.
- If the sensors must be replaced, then the valve must also be replaced at the same time.

 For the sake of the environment

Dispose of old tires in accordance with the local requirements. ■

Uniform tire quality grading

- Tread wear
- Traction AA A B C
- Temperature A B C

Quality grades can be found where applicable on the tire side wall between tread shoulder and maximum section width ⇒ *page 288*, fig. 214.

For example: Tread wear **200**, Traction **AA**, Temperature **A**.

All passenger car tires must conform to Federal Safety Requirements in addition to these grades.


Tread wear

The *tread wear* grade is a comparative rating based on the wear rate of the tire when tested under controlled conditions on a specified government test course.

For example, a tire graded 150 would wear one and one half (1 1/2) times as well on the government course as a tire graded 100.


The relative performance of tires depends upon the actual conditions of their use, however, and may depart significantly from the norm due to variations in driving habits, service practices and differences in road characteristics and climate.

Traction

The *traction* grades, from highest to lowest, are AA, A, B and C. Those grades represent the tire's ability to stop on wet pavement as measured under controlled conditions on specified government test surfaces of asphalt and concrete. A tire marked C may have poor traction performance ⇒ .

Temperature

The *temperature* grades are A (the highest), B, and C, representing the tire's resistance to the generation of heat and its ability to dissipate heat when tested under controlled conditions on a specified indoor laboratory test wheel.

Sustained high temperature can cause the material of the tire to degenerate and reduce tire life, and excessive temperature can lead to sudden tire failure ⇒ .

The grade C corresponds to a level of performance which all passenger car tires must meet under the Federal Motor Vehicle Safety Standard No. 109. Grades B and A represent higher levels of performance on the laboratory test wheel than the minimum required by law.

WARNING

The traction grade assigned to this tire is based on straight-ahead braking traction tests, and does not include acceleration, cornering, hydroplaning or peak traction characteristics.


WARNING

The temperature grade for this tire is established for a tire that is properly inflated and not overloaded. Excessive speed, underinflation, or excessive loading, either separately or in combination, can cause heat buildup and possible tire failure. ■

Winter tires

Winter tires can improve vehicle handling on snow and ice. At temperatures below 45 °F (7 °C) we recommend changing to winter tires.

In some heavy snow areas, local governments may require true winter or "snow" tires, those with very deeply cut tread. These tires should only be used in pairs and be installed on all four wheels. Make sure you purchase snow tires that are the same size and construction type as the other tires on your vehicle.

Your vehicle is equipped with all-wheel drive, this will improve traction during winter driving, even with the standard tires. However, we strongly recommend that you always equip all four wheels on 

your vehicle with correctly fitted winter tires or all-season tires, when winter road conditions are expected. This also improves the vehicle's braking performance and reduces stopping distances.

Summer tires provide less grip on ice and snow.

Winter tires (snow tires) must always be fitted on all four wheels.

Compatible tire pressure monitoring sensors must be installed on all four winter tires for the tire pressure monitoring system to function properly ⇒ *page 290*.

Ask your authorized Audi dealer or qualified workshop for permitted **winter tire sizes**. Use only radial winter tires.

Winter tires lose their effectiveness when the tread is worn down to a depth of 0.157 inch (4 mm).

Only drive with winter tires under winter conditions. Summer tires handle better when there is no snow or ice on the roads and the temperature is above 45 °F (7 °C).

If you have a flat tire, see notes on spare wheel ⇒ *page 288*.

Please always remember that winter tires may have a lower speed rating than the tires originally installed on your vehicle at the time it was manufactured. Please see ⇒ *page 289*, "Speed rating (letter code)" for a listing of the speed rating letter codes and the maximum speed at which the tires can be driven.

The speed rating letter code (⇒ *page 279*) is on the side wall of the tire ⇒ *page 288*.

WARNING

Winter tires have maximum speed limits that may be lower than your vehicle's maximum speed. Always know the maximum speed before driving off. Never drive faster than the speed permitted for your specific winter tires. This will cause damage to the tires leading to an accident and serious personal injury to you and your passengers.

WARNING

Driving faster than the maximum speed for which the winter tires on your vehicle were designed can cause tire failure including a blowout and sudden deflation, loss of control, crashes and serious personal injuries. Have worn or damaged tires replaced immediately.

- Winter tires have maximum speed rating that may be lower than your vehicle's maximum speed.
- Never drive faster than the speed for which the winter or other tires installed on your vehicle are rated.

WARNING

Always adjust your driving to the road and traffic conditions. Never let the good acceleration of the winter tires and all-wheel drive tempt you into taking extra risks. Always remember:

- When braking, an all-wheel drive vehicle handles in the same way as a front drive vehicle.
- Drive carefully and reduce your speed on icy and slippery roads, even winter tires cannot help under black ice conditions.


For the sake of the environment

Use summer tires when weather conditions permit. They are quieter, do not wear as quickly and reduce fuel consumption. ■

Snow chains

Snow chains may be fitted only to the front wheels, and only to certain tire sizes. Ask your authorized Audi dealer on which tire sizes snow chains can be used.

The snow chains must have low-profile links and must not be thicker than 0.53 inch (13.5 mm), including the lock. ►

Remove wheel center covers and trim discs before putting snow chains on your vehicle ⇒ . For safety reasons cover caps must then be fitted over the wheel bolts. These are available from authorized Audi dealers.

WARNING

Using the wrong snow chains for your vehicle or installing them incorrectly can increase the risk of loss of control leading to serious personal injury.

- **Snow chains are available in different sizes. Always make sure to follow the instructions provided by the snow chain manufacturer.**
- **When driving with snow chains never drive faster than the speed permitted for your specific snow chains.**
- **Always observe local regulations.**

Note

- Remove snow chains before driving on roads not covered with snow to avoid damaging tires and wearing the snow chains down unnecessarily.
- Snow chains, which come into direct contact with the wheel rim, can scratch or damage it. Therefore, make sure that the snow chains are suitably covered.

Tips

Where snow chains are mandatory on certain roads, this normally also applies to vehicles with all wheel drive . ■

Wheel bolts

Wheel bolts must always be tightened to the correct torque.

The design of wheel bolts is matched to the factory installed rims. If different rims are fitted, the correct wheel bolts with the right length and correctly shaped bolt heads must be used. This ensures that wheels are fitted securely and that the brake system functions correctly.

In certain circumstances, you may not use wheel bolts from a different vehicle – even if it is the same model ⇒ *page 332*.

WARNING

Improperly tightened or maintained wheel bolts can become loose causing loss of control, a collision and serious personal injury.

- **Always keep the wheel bolts and the threads in the wheel hubs clean so the wheel bolts can turn easily and be properly tightened.**
- **Never grease or oil the wheel bolts and the threads in the wheel hubs. They can become loose while driving if greased or oiled, even if tightened to the specified torque.**
- **Only use wheel bolts that belong to the rim being installed.**
- **Never use different wheels bolts on your vehicle.**
- **Always maintain the correct tightening torque for the wheel bolts to reduce the risk of a wheel loss. If the tightening torque of the wheel bolts is too low, they can loosen and come out when the vehicle is moving. If the tightening torque is too high, the wheel bolts and threads can be damaged and the wheel can become loose.**

Note

The specified torque for the wheel bolts is 90 ft lb (120 Nm) with a tolerance of ± 7,4 ft lb (± 10 Nm). Torque wheel bolts diagonally. After changing a wheel, the torque must be checked as soon as

possible with a torque wrench – preferably by an authorized Audi dealer or qualified workshop. ■

Low aspect ratio tires

Your Audi is factory-equipped with low aspect ratio tires. These tires have been thoroughly tested and been selected specifically for your model for their superb performance, road feel and handling under a variety of driving conditions. Ask your authorized Audi dealer for more details.

The low aspect ratio of these tires is indicated by a numeral of **55 or less** in the tire's size designation. The numeral represents the ratio of the tire's sidewall height in relation to its tread width expressed in percentage. Conventional tires have a height/width ratio of 60 or more.

The performance of low-aspect-ratio tires is particularly sensitive to improper inflation pressure. It is therefore important that low aspect ratio tires are inflated to the specified pressure and that the inflation pressure is regularly checked and maintained. Tire pressures should be checked at least once a month and always before a long trip ⇒ page 282, "Checking tire pressure".

What you can do to avoid tire and rim damage

Low aspect ratio tires can be damaged more easily by impact with potholes, curbs, gullies or ridges on the road, particularly if the tire is underinflated.

In order to minimize the occurrence of impact damage to the tires of your vehicle, we recommend that you observe the following precautions:

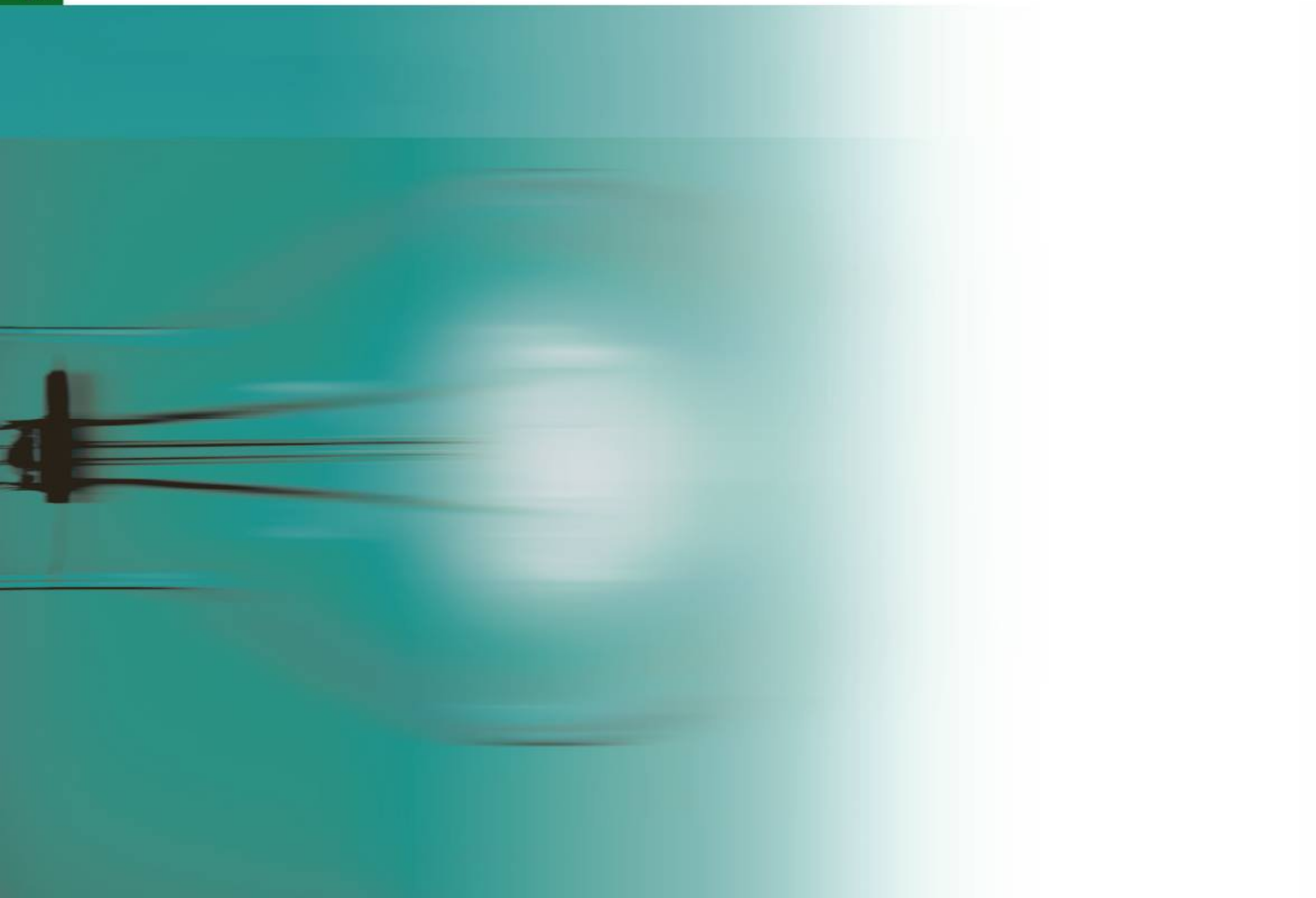
- Always maintain recommended inflation pressures. Check your tire pressure every 2,000 miles (3,000 km) and add air if necessary.
- Drive carefully on roads with potholes, deep gullies or ridges. The impact from driving through or over such obstacles can damage your tires. Impact with a curb may also cause damage to your tires.

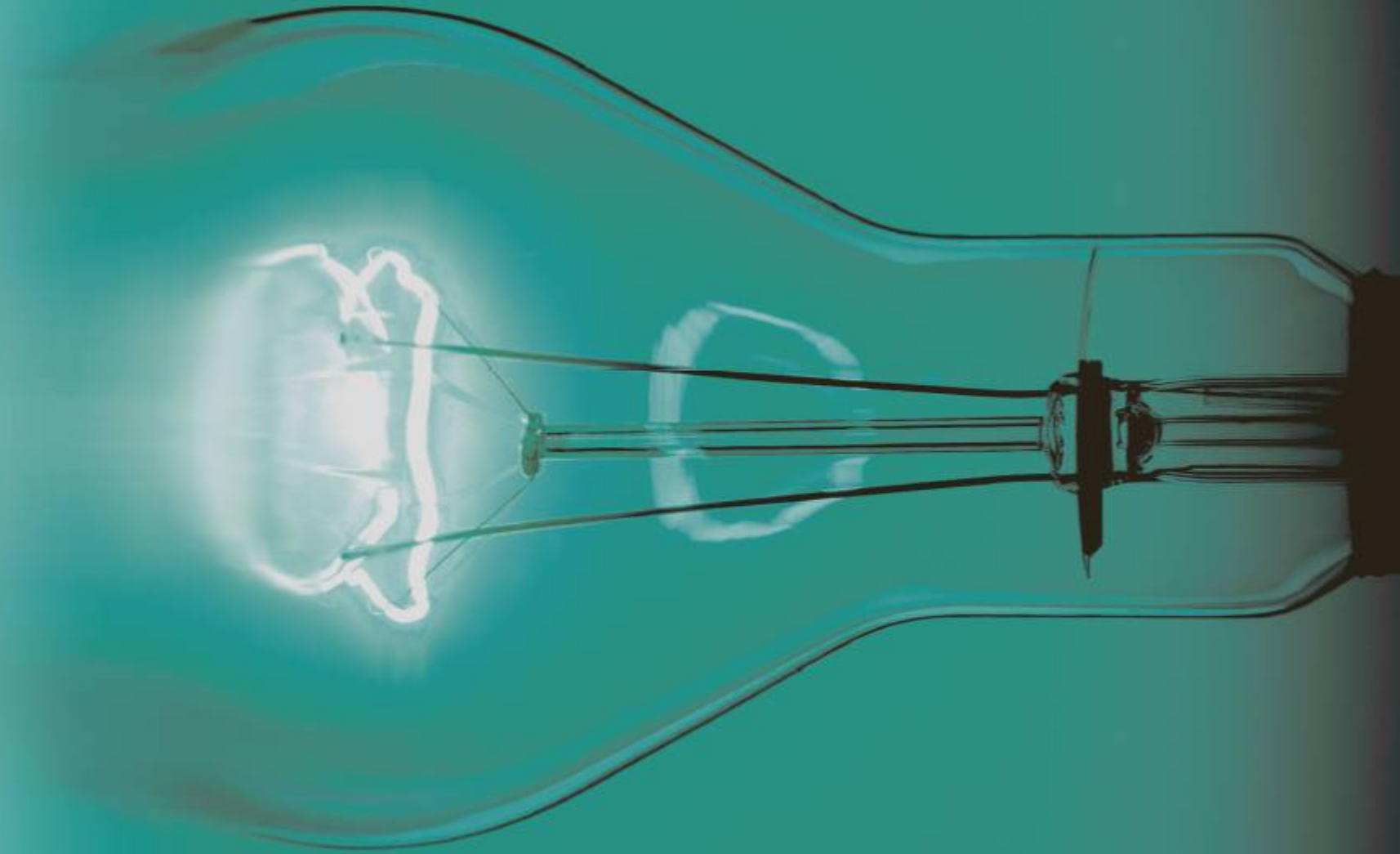
- After any impact, immediately inspect your tires or have them inspected by the nearest authorized Audi dealer. Replace a damaged tire as soon as possible.
- Inspect your tires every 2,000 miles (3,000 km) for damage and wear. Damage is not always easy to see. Damage can lead to loss of air and underinflation, which could eventually cause tire failure. If you believe that a tire may have been damaged, replace the tire as soon as possible.
- These tires may wear more quickly than others.
- Please also remember that, while these tires deliver responsive handling, they may ride less comfortably and make more noise than other choices.

Reduced performance in winter/cold season conditions

All tires are designed for certain purposes. The low aspect ratio, ultra high performance tires originally installed on your vehicle are intended for maximum dry and wet road performance and handling. They are not suitable for cold, snowy or icy weather conditions. If you drive under those circumstances, you should equip your vehicle with all-season or winter tires, which offer better traction under those conditions. We suggest you use the recommended snow or all-season tires specified for your vehicle, or their equivalent.

Refer to ⇒ page 292 for more detailed information regarding winter tires. ■





What do I do now?

Trunk escape handle

In case of an emergency, the rear lid can be opened from the inside using the trunk escape handle.



Fig. 215 Trunk escape handle: view from inside the closed trunk

To open rear lid

- Pull the handle down towards the bumper ⇒ fig. 215.

The trunk escape handle inside the rear lid is made of fluorescent material to glow in the dark.

WARNING

The trunk escape handle is to be used only in an emergency.

Tips

The emergency release lever should *never* be used as a handle for closing the rear lid. ■

Vehicle tool kit

The tools are stored underneath the floor panel in the luggage compartment.

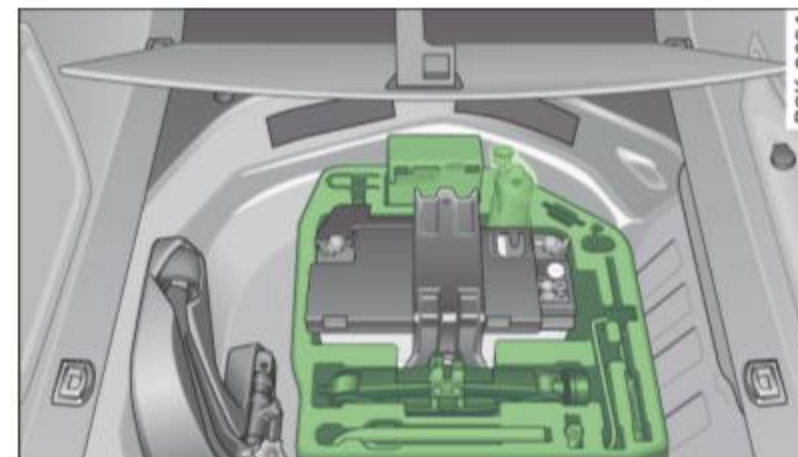


Fig. 216 Luggage compartment: tool kit and tire mobility system

When you need access to the vehicle tool kit, tire mobility system or jack*, you will need to take out the spare tire* and cover ⇒ *page 300*.

The vehicle tool kit includes:

- Hook for removing wheel covers*
- Alignment pin for changing the wheel
- Screwdriver with reversible blade
- Tool for changing light bulbs
- Reversible bit (reversible Torx bit for changing light bulbs)
- Rod for jack
- Jack*
- Lug wrench
- Towing eye

Some of the vehicle items listed above are provided on certain models only or are optional extras.

Before returning the jack* to its place, retract the jack arm fully. ►

! WARNING

- Never use the screw driver hex head to tighten wheel bolts, since the bolts cannot attain the necessary tightening torque if you use the hex head, potentially causing an accident.
- The factory-supplied jack is intended only for your vehicle model. Under no circumstances should it be used to lift heavy vehicles or other loads; you risk injuring yourself.
- Never start the engine when the vehicle is raised, which could cause an accident.
- Support the vehicle securely with appropriate stands if work is to be performed underneath the vehicle; otherwise, there is a potential risk for injury. ■

Applies to vehicles: with tire mobility system

Tire mobility system

You will find the tire mobility system under the floor in the luggage compartment.

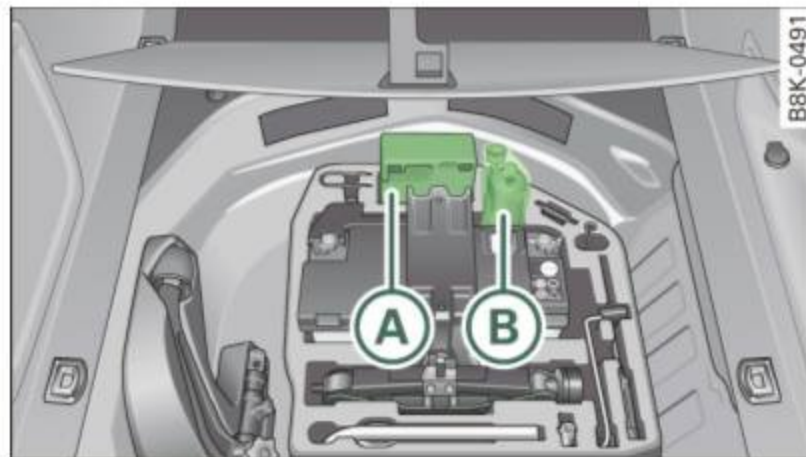


Fig. 217 Luggage compartment: tire mobility system

The vehicle is equipped with a tire repair kit (a tire mobility system) in the event of a flat tire.

The tire mobility system consists of a **tire sealant** ⇒ fig. 217 (B) to protect the tire from damage and a **compressor** (A) to generate the

required tire pressure. This can safely seal a tire from damage by foreign objects that are up to about 0.16 inch (4 mm) in diameter. The foreign object can stay in the tire.

Brief instructions on how to use the tire sealant and/or the compressor are located on the sealant bottle and/or compressor housing.

! WARNING

- Only use the tire mobility system if the tire was not previously damaged due to driving without air. You should therefore especially check for damage to the sidewall of the tire.
- Carefully follow the safety and handling instructions on the compressor and sealant bottle.
- Do not drive faster than 50 mph (80 km/h)!
- Avoid full-throttle acceleration, heavy braking, and fast cornering!
- Tires repaired using the tire mobility system or the tire sealant are only intended for temporary, short-term use. Have the defective tire replaced as quickly as possible.

! Note

Do not use commercially available tire sealants. The electrical components of the tire pressure monitoring system will no longer work properly.

🌱 For the sake of the environment

You can dispose of used sealant bottles at an Audi dealership.

i Tips

Seek professional assistance if it is not possible to repair the tire with the tire sealant. ■

Applies to vehicles: with space-saving spare tire

Space-saving spare tire (compact spare tire)*

The spare tire/wheel is located in the luggage compartment under the cargo floor cover. It is intended for short-term use only.



Fig. 218 Spare tire

Removing the spare tire

- Lift the cargo floor by the plastic handle ⇒ fig. 218.
- Hook the handle into the luggage compartment weather strip.
- Turn the large screw ⇒ fig. 218 counter-clockwise.
- Take out the spare tire.
- Unhook the cargo floor before closing the rear lid.

Securing the replaced tire

- Place the wheel with tire in the spare wheel well and secure the wheel with the large screw.
- Unhook the cargo floor before closing the rear lid.

Using the spare tire (compact spare tire)

The compact spare tire is only intended for emergencies until you can reach a repair shop. Replace it as quickly as possible with a standard wheel and tire.

There are some restrictions on the use of the compact spare tire. The compact spare tire has been designed specifically for your type of vehicle. It must not be swapped with a compact spare tire from another type of vehicle.

Snow chains

For technical reasons, the use of snow chains on the compact spare tire is **not permitted**.

If you do have to drive with snow chains and a *front tire* fails, mount the spare wheel with tire instead of a rear tire. Install the snow chains on the rear tire and use it to replace the defective front tire.

WARNING

- **Never use the spare tire if it is damaged or if it is worn down to the tread wear indicators.**
- **If the spare tire is more than 6 years old, use it only in an emergency and with extreme caution and careful driving.**
- **The spare tire is intended only for temporary and short-term use. It should be replaced as soon as possible with the normal wheel and tire.**
- **After mounting the compact spare tire, the tire pressure must be checked as soon as possible. The tire pressure of the compact spare tire must be 4.2 bar; otherwise, you risk having an accident.**
- **Do not drive faster than 50 mph (80 km/h). You risk having an accident.**
- **Avoid full-throttle acceleration, heavy braking, and fast cornering. You risk having an accident.**
- **Never drive using more than one spare wheel and tire. You risk having an accident.**

⚠ WARNING (continued)

- Normal summer or winter tires must not be mounted on the compact spare wheel rim.
- For technical reasons, the use of tire chains on the spare tire is not permitted. If it is necessary to drive with tire chains, the spare wheel must be mounted on the front axle in the event of a flat in a rear tire. The newly available front wheel must then be installed in place of the rear wheel with the flat tire. Installing the tire chain before mounting the wheel and tire is recommended.
- Loose items in the passenger compartment can cause serious personal injury during hard braking or in an accident.
 - Never store the inflatable spare tire or jack and tools in the passenger compartment.
 - Always store all jacking equipment, tools, and the inflatable spare tire in the luggage compartment.
 - Tighten the knurled retaining screw for the inflatable spare tire securely. ■

Tire repair

Applies to vehicles: with tire mobility system

General and safety pointers

Tire repair is intended only for temporary, short-term use.



Fig. 219 Tire damage for which the tire mobility system is not suited

Your vehicle is equipped with a tire repair kit, the **tire mobility system (TMS)**.

In the event of a tire failure, the **TMS** is in the luggage compartment under the floor. It consists of the tire sealant and an electric air pump.

Using **TMS**, tire damage caused by foreign bodies up to about **0.16 inch (4 mm)** in diameter can be sealed reliably.

The foreign object can stay in the tire.

The tire sealant must not be used:

- for cuts or punctures in the tire which are larger than 0.16 inch (4 mm) ⇒ fig. 219 ①
- for damage to the rim ②
- if you have been driving with very low tire pressures or tires with no air ③

Using the **TMS** is described in the section ⇒ *page 302*, "Repairing a tire".

TMS can be used at temperatures down to $-4\text{ }^{\circ}\text{F}$ ($-20\text{ }^{\circ}\text{C}$).

WARNING

Take the following precautions after repairing the tire:

- Do not drive faster than 50 mph (80 km/h)!
- Avoid full-throttle acceleration, heavy braking and fast cornering.
- The vehicle's road behavior can be affected.
- Tires sealed with TMS are intended only for temporary, short-term use.
- After using the tire sealant the tire pressure monitoring system may no longer work properly. Drive carefully to the next professional repair facility.
- TMS must NOT be used,
 - for cuts or punctures in the tire which are larger than 0.16 inch (4 mm)
 - for damage to the rim
 - if you have been driving with very low tire pressures or tires with no air.
- Seek professional assistance if it is not possible to repair the tire with the tire sealant.

WARNING

The tire sealant must not come into contact with skin, eyes or clothing.

- If you get any tire sealant in your eyes or come into contact with it, rinse the affected area thoroughly with clean water. Find a physician immediately!
- Change any clothing contaminated with tire sealant immediately.
- Do not inhale the vapor!

WARNING (continued)

- If you have swallowed tire sealant, rinse your mouth thoroughly right away and drink plenty of water.
 - Do not induce vomiting! Find a physician immediately!
- If you have allergic reactions, find a physician immediately.
- Keep the tire sealant away from children.



For the sake of the environment

Used sealant bottles can be dropped off at a recycling facility.



Tips

- If sealant has run out, allow it to dry. Then you can peel it off.
- Have the tire sealant replaced every 4 years at an authorized Audi dealer or other qualified workshop. ■

Applies to vehicles: with tire mobility system






Repairing a tire



Fig. 220 Tire mobility system: filling a tire

Preliminary steps

- If you have a flat tire, park the vehicle as far as possible from moving traffic. ▶

- Engage the **parking brake** to prevent your vehicle from rolling unintentionally ⇒ .
- Move **selector lever to position P** on a automatic transmission; put manual transmission in **first gear** ⇒ .
- Check whether a repair using the tire mobility system is possible ⇒ *page 301, "General and safety pointers"*.
- Have all passengers **leave** the vehicle and stay away from the danger zone ⇒ .
- Take the **sealant bottle** ⇒ *page 299, fig. 217*  and the **electric air pump**  from the luggage compartment under the floor.
- Place the "max. 50 mph" (80 km/h) sticker on the instrument cluster within the driver's field of vision.

Filling tires

- Shake the bottle well before filling.
- Screw the accompanying filler hose on the bottle.
- Remove the tire's valve stem cap, and use the accompanying valve core turner to unscrew the valve core ⇒ *page 302, fig. 220*.
- Remove the sealing plug of the filler hose and connect the hose to the tire valve.
- Hold the bottle with the bottom facing upward ⇒ *page 302, fig. 220*, and fill the tire using the entire substance of the bottle.
- Then, remove the hose and tightly screw the valve core back on the tire valve.

Inflating tires


- Screw the compressor filler hose onto the tire valve and plug the connector into the cigarette lighter.
- Fill up the tire to a pressure ranging from 2.0 to 2.5 bar, and check the pressure gauge readout.
- If this pressure is not reached, drive your vehicle approx. 33 feet (10 meters) forward or backward in order to evenly distribute the sealant in the tire. If the required air pressure still cannot be reached, the tire is too severely damaged. A repair with the tire sealant is not possible.

Final check

- After driving for about 10 minutes, stop and check the tire pressure.
- If tire pressure is less than 1.3 bar, the tire is too severely damaged. Do not continue to drive. Seek professional assistance.

WARNING

- Turn the hazard flashers on and set up the warning triangle if you have a flat tire in moving traffic. In this way you protect yourself and other road users.
- Make sure that all passengers are in a safe place, out of the danger zone (for example, behind a guard rail).
- Please note the manufacturer's safety tips on the compressor sticker and the sealant bottle user's manual.
- If a tire pressure of 2.0 bar cannot be reached after filling for six minutes, the tire is too severely damaged. Do not continue to drive!
- Seek professional assistance if it is not possible to repair the tire with the sealant.

 **WARNING** (continued)

- If tire pressure is less than 1.3 bar after driving for 10 minutes, the tire is too severely damaged. Do not continue to drive. Seek professional assistance.

 **Note**

Particular care is necessary if you are making a tire repair on a steep incline.



 **Tips**


- Do not operate the electric air pump for more than 6 minutes without stopping, otherwise it can overheat. When the air pump has cooled down, you can continue to use it.
- If sealant has escaped, allow it to dry, then you can peel it off.
- After a tire repair, have the sealant bottle replaced at an authorized Audi dealer or other qualified workshop. This restores full functionality to the tire mobility system.
- Obey all laws. ■

Changing a wheel

Before changing a wheel

Observe the following precautions for your own and your passenger's safety when changing a wheel.

- After you experience a tire failure, pull the car well away from moving traffic and try to reach **level** ground before you stop ⇒ .
- All passengers should **leave the car** and move to a safe location (for instance, behind the guardrail) ⇒ .

- Engage the **parking brake** to prevent your vehicle from rolling unintentionally ⇒ .
- Shift into **1st gear** on vehicles with manual transmission, or move the **selector lever to the P position** on vehicles with automatic transmission.
- If you are towing a trailer: unhitch the trailer from your vehicle.
- Take the **jack** ⇒ *page 298* and the **spare tire** ⇒ *page 300* out of the luggage compartment.

 **WARNING**

You or your passengers could be injured while changing a wheel if you do not follow these safety precautions:

- If you have a flat tire, move a safe distance off the road. Turn off the engine, turn the emergency flashers on and use other warning devices to alert other motorists.
- Make sure that passengers wait in a safe place away from the vehicle and well away from the road and traffic.
- To help prevent the vehicle from moving suddenly and possibly slipping off the jack, always fully set the parking brake and block the wheel diagonally opposite the wheel being changed with the folding chocks or other objects. When one front wheel is lifted off the ground, placing the Automatic Transmission in "P" (Park) will *not* prevent the vehicle from moving.
- Before you change a wheel, be sure the ground is level and firm. If necessary, use a sturdy board under the jack.
- After installing the inflatable spare tire, make sure that you replace the flat tire/wheel in its storage area properly and tighten the knurled retaining screw securely.

Note

If you are changing the wheel on a steep incline, use a rock or similar object to block the opposite wheel to prevent the vehicle from moving.

Tips

Obey all laws. ■

Changing a wheel

When you change a wheel, follow the sequence described below step-by-step and in exactly that order.

1. Remove the **decorative wheel cover***. For more details see also ⇒ *page 306, "Decorative wheel covers"*.
2. Loosen the **wheel bolts** ⇒ *page 307*.
3. Locate the proper mounting point for the jack and align the jack below that point ⇒ *page 307*.
4. **Lift** the car with the jack ⇒ *page 307*.
5. Remove the **wheel with the flat tire** and then install the **spare tire** ⇒ *page 309*.
6. Tighten all wheel bolts lightly.
7. **Lower** the vehicle with the jack.
8. Use the wheel bolt wrench and **firmly** tighten all wheel bolts in a crisscross pattern ⇒ *page 307*.
9. Replace the decorative **wheel cover***.

WARNING

Always read and follow all WARNINGS and information ⇒  in "Raising the vehicle" on *page 307* and ⇒ *page 310*. ■

After changing a wheel

A wheel change is not complete without the doing the following.

- **Store and secure** the wheel you replaced in the spare wheel well.
- Replace the tools and the jack in their proper location.
- Check the **tire pressure** of the spare tire as soon as possible.
- As soon as possible, have the **tightening torques** on all wheel bolts checked with a torque wrench. The correct tightening torque is 90 ft lb (120 Nm).
- Have the flat tire **replaced** as soon as possible.

Tips

- If you notice that the wheel bolts are corroded and difficult to turn while changing a tire, they should be replaced before you check the tightening torque.
- Drive at reduced speed until you have the tightening torques checked. ■

Applies to vehicles: with decorative wheel covers

Decorative wheel covers

The decorative wheel covers must be removed first to access the wheel bolts.

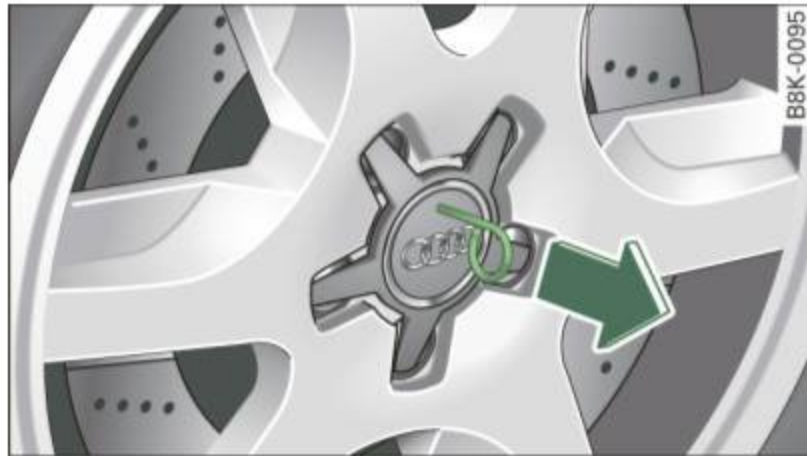


Fig. 221 Changing a wheel: removing the wheel cover

Removing

- Insert the **hook** provided with the vehicle tool kit in the hole in the hub.
- Pull off the **decorative wheel cover** ⇒ fig. 221. ■

Applies to vehicles: with wheel bolts with caps

Wheels with wheel bolt caps

The caps must be removed first from the wheel bolts before the bolts can be unscrewed.

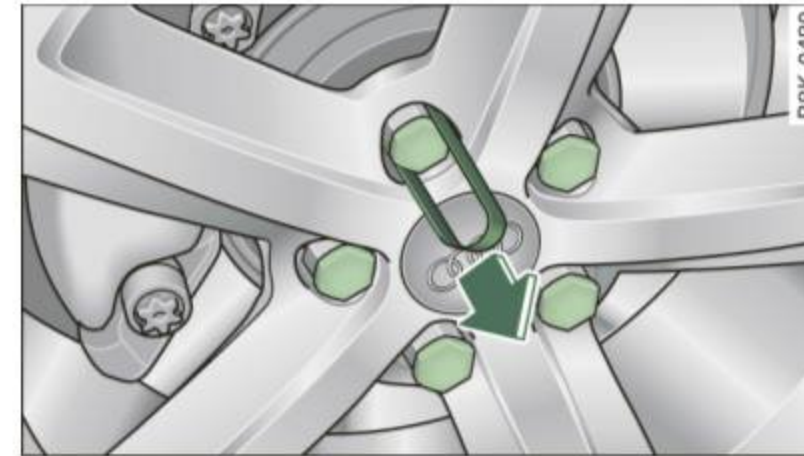


Fig. 222 Changing a wheel: removing the wheel bolt caps

Removing

- Push the **plastic clip** provided with the vehicle tool kit over the wheel bolt cap until it engages.
- Pull on the **plastic clip** to remove the cap ⇒ fig. 222.

Refitting

- Place the caps over the wheel bolts and push them back on.

The caps are to protect and keep the wheel bolts clean. ■

Loosening and tightening the wheel bolts

The wheel bolts must be loosened before raising the vehicle.



Fig. 223 Changing a wheel: loosening the wheel bolts

Loosening

- Install the **wheel bolt wrench** over the wheel bolt and push it down as far as it will go.
- Take tight hold of the *end* of the wrench handle and turn the wheel bolts **counter-clockwise** about *one single* turn in the direction of arrow ⇒ fig. 223.

Tightening

- Install the **wheel bolt wrench** over the wheel bolt and push it down as far as it will go.
- Take tight hold of the *end* of the wrench handle and turn each wheel bolt **clockwise** until it is seated.

! WARNING

- Do not use force or hurry when changing a wheel - you can cause the vehicle to slip off the jack and cause serious personal injuries.

! WARNING (continued)

- Do not loosen the wheel bolts *more than one turn* before you raise the vehicle with the jack. - You risk an injury.

i Tips

- Never use the hexagonal socket in the handle of the screwdriver to loosen or tighten the wheel bolts.
- If a wheel bolt is very tight, you may find it easier to loosen by carefully pushing down on the end of the wheel bolt wrench with *one foot only*. As you do so, hold on to the car to keep your balance and take care not to slip. ■

Raising the vehicle

The vehicle must be lifted with the jack first before the wheel can be removed.

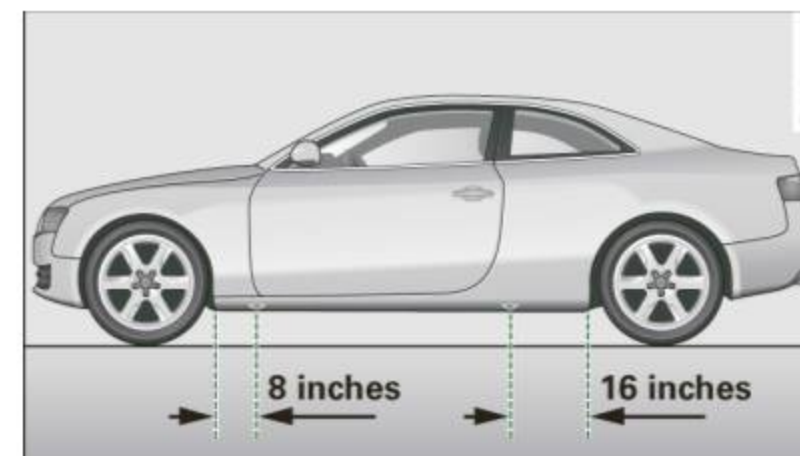


Fig. 224 Changing a wheel: mounting points for the jack

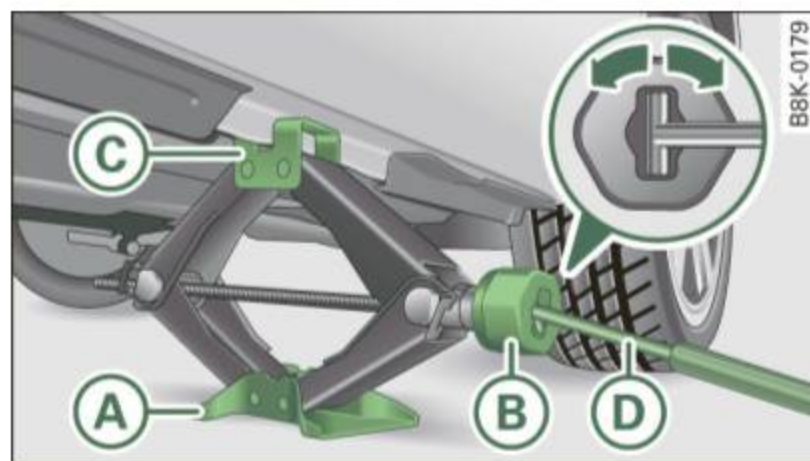


Fig. 225 Close-up:
proper positioning of
jack

The location of the jack point is indicated by an indentation on the underside of the vehicle ⇒ fig. 224.

- Place the jack on the **jack point** closest to the defective wheel/tire. Make sure that the base plate (A) is flat on the ground ⇒ ⚠.
- Crank up the jack on the handwheel (B) until it is high enough so that its claw (C) completely covers the **seam** on your vehicle ⇒ fig. 225.
- Now attach the rod (D) to the jack: Stick the rod into the opening on the handwheel ⇒ fig. 225. Turn the rod left or right to secure it.
- Continue to crank the jack with the rod until the wheel is lifted just clear of the ground ⇒ ⚠.

Indentations on the beam under the vehicle mark the locations in the front and back where the jack can be placed ⇒ fig. 224. There is exactly *one* location for each wheel. The distance between the jack point and the wheel opening is about 8 inches (20 cm) in front and about 16 inches (40 cm) in back. The jack must be placed only on the seam at the jack points indicated ⇒ ⚠.

Soft ground under the jack can cause the vehicle to slip off the jack. Always place the jack on firm ground. You should therefore use a

flat, stable support, if necessary. On a slippery surface such as tile, you should use a non-slip pad (such as a rubber mat) ⇒ ⚠.

⚠ WARNING

- You or your passengers could be injured while changing a wheel if you do not follow these safety precautions:
 - Positioning the jack under the vehicle at any other place than those indicated above may damage the vehicle or may result in personal injuries.
 - A soft or unstable surface under the jack may cause the vehicle to slip off the jack. Always provide a firm base for the jack on the ground. If necessary, use a sturdy board under the jack.
 - On hard, slippery surface (such as tiles) use a rubber mat or similar to prevent the jack from slipping.
- To help prevent injury to yourself and your passengers:
 - Do not raise the vehicle until you are sure the jack is securely engaged.
 - Passengers must not remain in the vehicle when it is jacked up.
 - Make sure that passengers wait in a safe place away from the vehicle and well away from the road and traffic.
 - Make sure jack position is correct, adjust as necessary and then continue to raise the jack. ■

Taking the wheel off/installing the spare tire

Follow these instructions step-by-step for changing the wheel



Fig. 226 Changing a wheel: using the screwdriver handle (with the blade removed) to turn the bolts



Fig. 227 Changing a wheel: alignment pin inside the top hole

After you have loosened all wheel bolts and raised the vehicle off the ground, remove and replace the wheel as follows:

Removing the wheel

- Remove the topmost wheel bolt completely with the **hexagonal socket** in the screwdriver handle (vehicle tool kit) ⇒ fig. 226 and set it aside on a *clean* surface.

- Screw the threaded end of the **alignment pin** from the tool kit hand-tight into the empty bolt hole ⇒ *page 309*, fig. 227.
- Then remove the other wheel bolts as described above.
- Take off the wheel leaving the alignment pin in the bolt hole.

Putting on the inflatable spare tire

- Push the spare tire over the alignment pin.
- Screw on the wheel bolts and tighten them *slightly* using the hexagonal socket.
- Remove the alignment pin and insert and tighten the remaining wheel bolt slightly like the rest.
- Turn the jack handle counter-clockwise to lower the vehicle until the jack is fully released.
- Use the wheel bolt wrench to tighten all wheel bolts firmly ⇒ *page 307*. Tighten them *in a criss-cross pattern*, from one bolt to the (approximately) opposite one, to keep the wheel centered.
- Perform the steps required after changing the wheel ⇒ *page 305*, "After changing a wheel".

The hexagonal socket makes it easier to remove the wheel bolts from the rim. Care should be taken when removing the reversible blade.



Tips

- When mounting tires with **unidirectional tread design** make sure the tread pattern is pointed the right way ⇒ *page 310*. ▶

- The wheel bolts should be clean and easy to turn. Check for dirt and corrosion on the mating surfaces of both the wheel and the hub. Remove all dirt from these surfaces before remounting the wheel.
- Do not use the hexagonal socket in the screwdriver handle to loosen or tighten the wheel bolts. ■

Tires with unidirectional tread design

Tires with unidirectional tread design must be mounted with their tread pattern pointed in the right direction.

Using a spare tire with a tread pattern intended for use in a specific direction

When using a spare tire with a tread pattern intended for use in a specific direction, please note the following:

- The direction of rotation is marked by an **arrow on the side of the tire**.
- If the spare tire has to be installed in the incorrect direction, use the spare tire only temporarily since the tire will not be able to achieve its optimum performance characteristics with regard to aquaplaning, noise and wear.
- We recommend that you pay particular attention to this fact during wet weather and that you adjust your speed to match road conditions.
- Replace the flat tire with a new one and have it installed on your vehicle as soon as possible to restore the handling advantages of a unidirectional tire. ■

Notes on wheel changing

Please read the information ⇒ *page 288*, "New tires and replacing tires and wheels" if you are going to use a spare tire which is different from the tires on your vehicle.

After you change a tire:

- **Check the tire pressure on the spare immediately after installation.**
- **Have the wheel bolt tightening torque checked with a torque wrench as soon as possible by your authorized Audi dealer or a qualified workshop.**
- **With steel and alloy wheel rims, the wheel bolts are correctly tightened at a torque of 90 ft lb (120 Nm).**
- **If you notice that the wheel bolts are corroded and difficult to turn while changing a tire, they should be replaced before you check the tightening torque.**
- **Replace the flat tire with a new one and have it installed on your vehicle as soon as possible. Remount the wheel cover.**

Until then, drive with extra care and at reduced speeds.



WARNING

- **If you are going to equip your vehicle with tires or rims which differ from those which were factory installed, then be sure to read the information ⇒ *page 288*, "New tires and replacing tires and wheels".**
- **Always make sure the damaged wheel or even a flat tire and the jack and tool kit are properly secured in the luggage compartment and are not loose in the passenger compartment.**
- **In an accident or sudden maneuver they could fly forward, injuring anyone in the vehicle.**
- **Always store damaged wheel, jack and tools securely in the luggage compartment. Otherwise, in an accident or sudden maneuver they could fly forward, causing injury to passengers in the vehicle.**



Note

Do not use commercially available tire sealants. Otherwise, the electrical components of the tire pressure monitoring system will no

longer work properly and the sensor for the tire pressure monitoring system will have to be replaced by a qualified workshop. ■

Fuses and bulbs

Fuses

Replacing a fuse

A problem in the electrical system may be caused by a blown fuse.



Fig. 228 Instrument panel left: Face cover

- Locate the fuse which belongs to the component which failed.
- Switch off the ignition and the electrical component affected.
- Carefully pry the face cover off the instrument panel using a screwdriver ⇒ fig. 228.
- Remove the plastic clip from its retainer in the face cover, place it over the questionable fuse and remove the fuse.
- Replace a blown fuse (recognizable by the melted metal strip inside) with a fuse of the *same* amperage.

The individual circuits are protected by fuses. The fuse panels with the fuses are located on the left and right front faces of the instru-

ment panel behind a cover and in the right storage area in the luggage compartment.

There is a plastic clip in the cover on the left side of the instrument panel, which can be used to remove the fuses. You will also find a label on both covers in the instrument panel with the fuse layout for the corresponding fuse panel.

WARNING

Never replace a fuse with one that has a higher amperage rating.

- **A fuse with a too high amperage could damage the electrical part and cause a fire.**

Note

- On no account should fuses be repaired (e.g. patched up with tin foil or wire) as this may cause serious damage elsewhere in the electrical circuit or cause fire.
- If a fuse blows repeatedly, do not keep replacing it. Instead, have the cause of the repeated short circuit or overload located and fixed.

Tips

You are well advised to keep a supply of spare fuses in your vehicle. Fuses with the proper ampere ratings are available at your authorized Audi dealer. ■

Fuse Location, Instrument Panel left



Fig. 229 Fuse panel layout

Some of the equipment items listed are optional or only available on certain model configurations.

Note that the following table is accurate at the time of going to press and is subject to change. In the event of discrepancies, the label on the inside of the cover always takes precedence.

The power seats are protected by **circuit breakers**, which automatically reset after a few seconds after the overload has been remedied.

No.	Equipment	Amps
Fuse holder (black)		
1	Not used	
2	Clutch sensor	5
3	Garage door opener	5
4	Directional Stabilization Assistance control module	10
5	Air conditioner	5
6	Autom. headlight range control, right	5
7	Autom. headlight range control, left	5

No.	Equipment	Amps
8	Vehicle electrical system control module	5
9	Interior mirror	5
10	Gearshift gate	5
11	Heated washer jets	5
12	Air conditioner	5
Fuse holder (brown)		
1	Not used	
2	Clutch sensor	5
3	Fuel pump	25
4	Auxiliary water pump	5
5	Front seat heating	30
6	Electronic stabilization program (ESP)	10
7	Horn	25
8	Window lifter engine for door, left	30
9	Wiper and washer system	30
10	Electronic stabilization program (ESP)	25
11	Door, left	15
12	Rain sensor, light sensor	5
Fuse holder (red)		
1	Not used	
2	Not used	
3	Lumbar support	10
4	Not used	
5	Not used	
6	Vehicle electrical system control module	35

No.	Equipment	Amps
7	Vehicle electrical system control module	30
8	Vehicle electrical system control module	30
9	Sun roof	20
10	Vehicle electrical system control module	30
11	Not used	
12	Alarm system	5

Fuse Location, Instrument Panel right



Fig. 230 Fuse panel layout

Some of the equipment items listed are optional or only available on certain model configurations.

Note that the following table is accurate at the time of going to press and is subject to change. In the event of discrepancies, the label on the inside of the cover always takes precedence.

The power seats are protected by **circuit breakers**, which automatically reset after a few seconds after the overload has been remedied.

No.	Equipment	Amps
Fuse holder (black)		
1	Not used	
2	Not used	
3	Not used	
4	Not used	
5	Steering column switch module	5
6	Electronic stabilization program (ESP)	5
7	Diagnostic connector, Terminal 15	5
8	Data bus on board diagnostic interface	5
9	Not used	
10	Not used	
11	Not used	
12	Not used	
Fuse holder (brown)		
1	CD changer	5
2	Not used	
3	MMI/Radio	10/20
4	Light switch	5
5	Data bus on board diagnostic interface, Instrument cluster	5
6	Ignition lock	5
7	Not used	
8	Air conditioner blower	40
9	Steering column lock	5

No.	Equipment	Amps
10	Air conditioner	10
11	Diagnostic connector, Terminal 30	10
12	Steering column switch module	5

Fuse Location, Luggage Compartment right

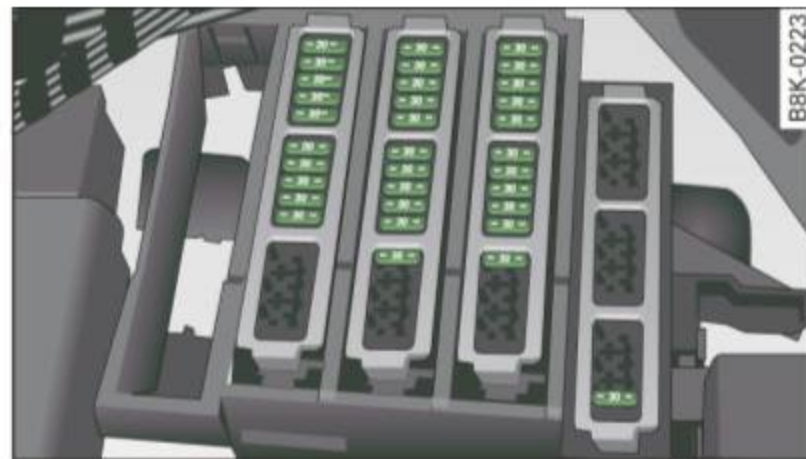


Fig. 231 Fuse panel layout

No.	Equipment	Amps
Fuse holder (black)		
1	Tire pressure monitoring system	5
2	Trailer towing	15
3	Trailer towing	20
4	Trailer towing	20
5	Electromechanical parking brake	5
6	Electronic dumping system	15
7	Electromechanical parking brake	30
8	Comfort system central control module	30
9	Not used	

No.	Equipment	Amps
10	Comfort system central control module	30
11	Comfort system central control module	20
12	Not used	
Fuse holder (brown)		
1	Converter with socket	15
2	Not used	
3	MMI/Radio	7,5
4	Digital sound system	30
5	Front information display	5/7,5
6	Not used	
7	Electromechanical parking brake	30
8	Rear seat heating	30
9	Window lifter engine for door, right	30
10	Not used	
11	Door, right	15
12	Rear view camera	5
Fuse holder (red)		
1	12 V socket (rear center console)	15
2	12 V socket (front center console)	15
3	12 V socket (luggage compartment)	15
4	Cigarette lighter/socket	15
5	Acoustic park assist	5
6	Telephone	5
7	Not used	
8	Not used	

No.	Equipment	Amps
9	Electromechanical parking brake	5
10	Lane Change Assistance control module	5
11	Rear seat heating	5
12	Airbag system	

Bulbs

Replacing bulbs

For your safety, we recommend that you have your authorized Audi dealer replace any bulbs for you.

It is becoming increasingly more and more difficult to replace vehicle light bulbs since in many cases, other parts of the car must first be removed before you are able to get to the bulb. This applies especially to the light bulbs in the front of your car which you can only reach through the engine compartment.

Sheet metal and bulb holders can have sharp edges that can cause serious cuts, parts must be correctly taken apart and then properly put back together to help prevent breakage of parts and long term damage from water that can enter housings that have not been properly resealed.

For your safety, we recommend that you have your authorized Audi dealer replace any bulbs for you, since your dealer has the proper tools, the correct bulbs and the expertise.

Gas discharge lamps (Xenon lights)*:


Due to the high electrical voltage, have the bulbs replaced by a qualified technician. Headlights with Xenon light are identified by the high voltage sticker.

WARNING

Changing Xenon lamps without the necessary equipment can cause serious personal injury.

- Bulbs are pressurized and can explode when being changed. Potential risk of injury!
- On vehicles equipped with gas discharge bulbs (Xenon light)* life-threatening injuries can result from improper handling of the high-voltage portions of such lamps!
- Only your authorized Audi dealer or a qualified workshop should change the bulbs in gas discharge lamps. There are parts with sharp edges on the openings and on the bulb holders that can cause serious cuts. If you are uncertain about what to do, have the work performed by an authorized Audi dealer or other qualified workshop. Serious personal injury may result from improperly performed work.

Tips

- If you still prefer to replace the light bulbs yourself, be aware that the engine compartment is a hazardous area to work in ⇒ *page 251*, "Engine compartment" ⇒ .
- It is best to ask your authorized Audi dealer whenever you want to change a bulb. ■

Emergency situations

General

This chapter is intended for trained emergency crews and working personnel who have the necessary tools and equipment to perform these operations. ■

Starting by pushing or towing



Note

Vehicles with an automatic transmission cannot be started by pushing or towing. ■

Starting with jumper cables

If necessary, the engine can be started by connecting it to the battery of another vehicle.

If the engine should fail to start because of a discharged or weak battery, the battery can be connected to the battery of *another* vehicle, using a **pair of jumper cables** to start the engine.

Jumper cables

Use *only* jumper cables of sufficiently large **cross section** to carry the starter current safely. Refer to the manufacturer's specifications.

Use only jumper cables with *insulated* terminal clamps which are distinctly marked:

plus (+) cable in most cases colored **red**

minus (-) cable in most cases colored **black**.



WARNING

Batteries contain electricity, acid, and gas. Any of these can cause very serious or fatal injury. Follow the instructions below for safe handling of your vehicle's battery.

- Always shield your eyes and avoid leaning over the battery whenever possible.
- A discharged battery can freeze at temperatures just below 32 °F (0 °C). Before connecting a jumper cable, you must thaw the frozen battery completely, otherwise it could explode.
- Do not allow battery acid to contact eyes or skin. Flush any contacted area with water immediately.
- Improper use of a booster battery to start a vehicle may cause an explosion.
- Vehicle batteries generate explosive gases. Keep sparks, flame and lighted cigarettes away from batteries.
- Do not try to jump start any vehicle with a low acid level in the battery.
- The voltage of the booster battery must also have a 12-Volt rating. The capacity (Ah) of the booster battery should not be lower than that of the discharged battery. Use of batteries of different voltage or substantially different "Ah" rating may cause an explosion and personal injury.
- Never charge a frozen battery. Gas trapped in the ice may cause an explosion.
- Never charge or use a battery that has been frozen. The battery case may have be weakened.
- Use of batteries of different voltage or substantially different capacity (Ah) rating may cause an explosion and injury. The capacity (Ah) of the booster battery should not be lower than that of the discharged battery.

⚠ WARNING (continued)

- Before you check anything in the engine compartment, always read and heed all WARNINGS ⇒ page 251, "Engine compartment".

! Note

- Applying a higher voltage booster battery will cause expensive damage to sensitive electronic components, such as control units, relays, radio, etc.
- There must be no electrical contact between the vehicles as otherwise current could already start to flow as soon as the positive (+) terminals are connected.

i Tips

- The discharged battery must be properly connected to the vehicle's electrical system. When jump starting or charging the battery, never connect the negative ground cable to the battery negative post because the battery manager system must be able to detect the battery's state of charge. Always connect the negative ground cable to the negative ground post of the battery manager control unit. ■

Use of jumper cables

Make sure to connect the jumper cable clamps in exactly the order described below!

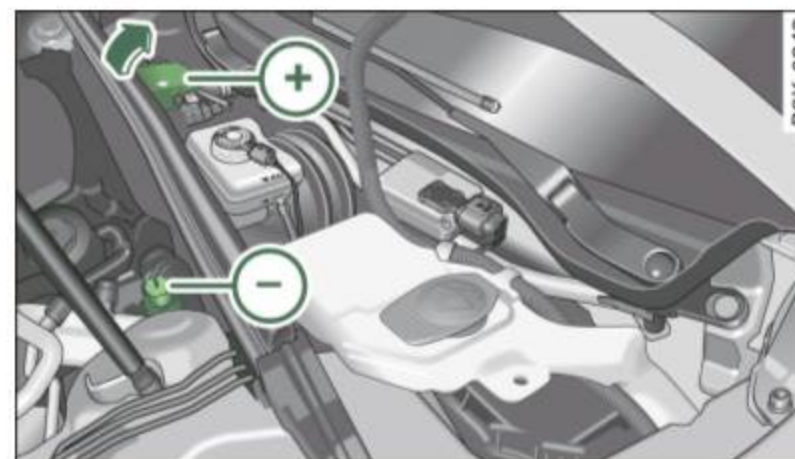


Fig. 232 Engine compartment: Connectors for jumper cables and charger

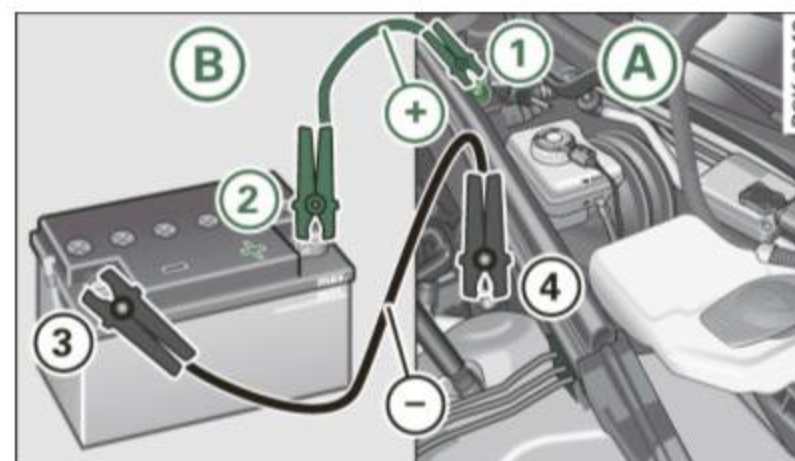


Fig. 233 Jump starting with the battery of another vehicle: A discharged vehicle battery, B booster battery

The procedure described below for connecting jumper cables is intended to provide a jump start for your vehicle.

Vehicle with discharged battery:

- Turn off lights and accessories, move lever of automatic transmission to **N** (Neutral) or **P** (Park) and set parking brake.

Connect POSITIVE (+) to POSITIVE (+) (red)

- Remove the cover above the jump start connection.
- Open the red cover on the positive pole ⇒ fig. 232.
- 1. Connect one end of the positive cable (red) on the **jump start bolt** ⇒ fig. 233 ① (Bolts under red cover = “positive”) of the vehicle to be started ①A.
- 2. Connect the other end to the positive terminal ② of the booster battery ②B.

Connect NEGATIVE (–) to NEGATIVE (–) (black)

- 3. Connect one end to the negative terminal ③ of the booster battery ③B.
- 4. Connect the other end of the negative cable (black) to the **jump start bolt** ④ (Bolts with hex head = “negative”) of the vehicle to be started ④A.

Starting the engine

- Start the engine of the vehicle with the booster battery. Run the engine at a moderate speed.
- Start engine with discharged vehicle battery in the usual manner.
- If the engine fails to start: do not keep the starter cranking for longer than 10 seconds. Wait for about 30 seconds and then try again.
- With engine running, remove jumper cables from both vehicles in the exact *reverse* order.
- Close the red cover on the positive pole.

The battery is vented to the outside to prevent gases from entering the vehicle interior. Make sure that the jumper clamps are well

connected with their *metal parts in full contact* with the battery terminals.

WARNING

To avoid serious personal injury and damage to the vehicle, heed all warnings and instructions of the jumper cable manufacturer. If in doubt, call for road service.

- Jumper cables must be long enough so that the vehicles do not touch.
- When connecting jumper cables, make sure that they cannot get caught in any moving parts in the engine compartment.
- Do not bend over the batteries - danger of chemical burns!
- The battery cell locking screws must be tightened securely.
- Before you check anything in the engine compartment, always read and heed all WARNINGS ⇒ *page 251, “Engine compartment”*.

Note

Improper hook-up of jumper cables can ruin the generator.

- Always connect POSITIVE (+) to POSITIVE (+), and NEGATIVE (–) to NEGATIVE (–) ground post of the battery manager control unit.
- Check that all screw plugs on the battery cells are screwed in firmly. If not, tighten plugs prior to connecting clamp on negative battery terminal.
- Please note that the procedure for connecting a jumper cable as described above applies specifically to the case of your vehicle being jump started. When you are giving a jump start to another vehicle, do *not* connect the negative (–) cable to the negative (–) terminal on the discharged battery ④ ⇒ *page 318, fig. 233*. Instead, securely connect the negative (–) cable to either a solid metal component that is firmly bolted to the engine block or to the engine block itself. If the battery that is being charged does not vent to the outside, escaping battery gas could ignite and explode! ■

Emergency towing with commercial tow truck

General hints

Your Audi requires special handling for towing.

The following information is to be used by commercial tow truck operators who know how to operate their equipment safely.

- **Never tow your Audi, towing will cause damage to the engine and transmission.**
- **Never wrap the safety chains or winch cables around the brake lines.**
- **To prevent unnecessary damage, your Audi must be transported with a flat bed truck.**
- **To load the vehicle on to the flat bed, use the towing loop found in the vehicle tools and attach to the front or rear anchorage**
⇒ *page 320* and ⇒ *page 321*.

WARNING

A vehicle being towed is not safe for passengers. Never allow anyone to ride in a vehicle being towed, for any reason. ■

Front towing loop

Do not install the front towing loop until it is needed.



Fig. 234 Front bumper: removing the cover cap



Fig. 235 Front bumper: screwing in the towing loop

The towing loop fits into the threaded hole located on the right side of the front bumper and covered by a small cover when not in use.

- Remove the towing loop from the vehicle toolkit
⇒ *page 298*.
- Press the cover in by applying short strong pressure to the bottom part to release it from the bumper ⇒ *fig. 234*.
- Screw the towing loop tightly into the threaded hole as far as it will go ⇒ *fig. 235*.

When it is no longer needed, unscrew the towing loop and put it back into the vehicle toolkit. Be sure to have the towing loop stored in the vehicle at all times.

WARNING

If the towing loop is not screwed in as far as it will go, the thread can pull out when the vehicle is towed - potential risk of an accident. ■

Rear towing loop

Do not install the rear towing loop until it is needed.

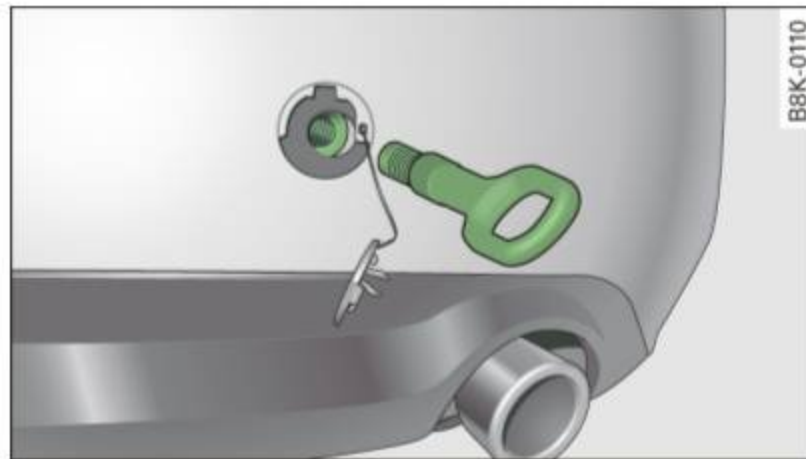


Fig. 236 Rear bumper: Screwing in towing loop

On the right side of the rear bumper there is a threaded hole for the towing loop. The threaded hole is protected by a cover.

- Remove the towing loop from the vehicle toolkit
⇒ *page 298.*
- Press the cover in by applying short strong pressure to the bottom part to release it from the bumper
⇒ *page 321, fig. 236.*

- Screw the towing loop tightly into the threaded hole as far as it will go.

Unscrew the towing loop again after use and install the cover in the bumper. Install the cover in the bumper. Return the towing loop to the toolkit. Be sure to have the towing loop stored in the vehicle at all times.

WARNING

If the towing loop is not screwed in as far as it will go, the thread can pull out when the vehicle is towed - potential risk of an accident. ■

Loading the vehicle onto a flat bed truck

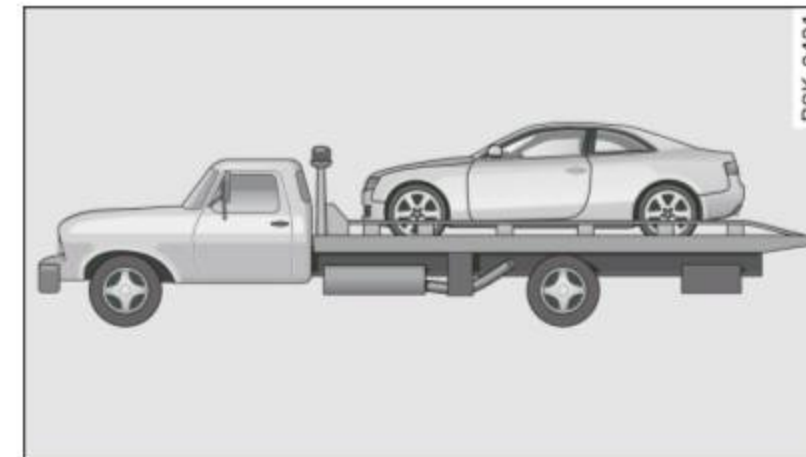


Fig. 237 Vehicle on flat bed truck

Front hook up

- Align the vehicle with the centerline of the car carrier ramp.
- Attach the winch hook to the front towline eye previously installed. ▶

Rear hook up

- Align the vehicle with the centerline of the car carrier ramp.
- Attach the winch hook to the rear towline eye previously installed.



Tips

Check carefully to make sure the hook-up is secure before moving the car up the flatbed truck ramp. ■

Lifting vehicle

Lifting with workshop hoist and with floor jack

The vehicle may only be lifted at the lifting points illustrated.

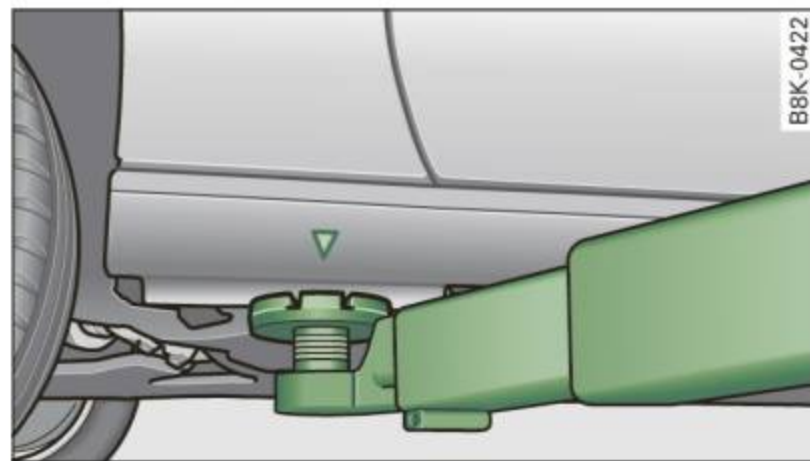


Fig. 238 Front lifting point

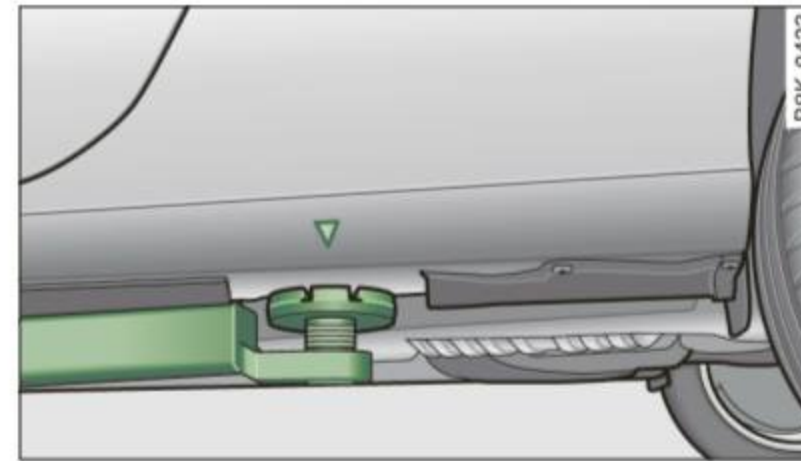



Fig. 239 Rear lifting point

- Read and heed WARNING ⇒ .
- Locate lifting points ⇒ fig. 238 and ⇒ fig. 239.
- Adjust lifting arms of workshop hoist or floor jack to match vehicle lifting points.
- Insert a rubber pad between the floor jack/workshop hoist and the lifting points.

If you must lift your vehicle with a floor jack to work underneath, be sure the vehicle is safely supported on stands intended for this purpose.

Front lifting point

The lifting point is located on the floor pan reinforcement about at the same level as the jack mounting point ⇒ fig. 238. **Do not lift the vehicle at the vertical sill reinforcement.**

Rear lifting point

The lifting point is located on the vertical reinforcement of the lower sill for the onboard jack ⇒ fig. 239.

Lifting with vehicle jack

Refer to ⇒ page 307.



 **WARNING**

- To reduce the risk of serious injury and vehicle damage.
 - Always lift the vehicle only at the special workshop hoist and floor jack lift points illustrated ⇒ fig. 238 and ⇒ fig. 239.
 - Failure to lift the vehicle at these points could cause the vehicle to tilt or fall from a lift if there is a change in vehicle weight distribution and balance. This might happen, for example, when heavy components such as the engine block or transmission are removed.
- When removing heavy components like these, anchor vehicle to hoist or add corresponding weights to maintain the center of gravity. Otherwise, the vehicle might tilt or slip off the hoist, causing serious personal injury.

 **Note**

- Be aware of the following points before lifting the vehicle:
 - The vehicle should never be lifted or jacked up from underneath the engine oil pan, the transmission housing, the front or rear axle or the body side members. This could lead to serious damage.
 - To avoid damage to the underbody or chassis frame, a rubber pad must be inserted between the floor jack and the lift points.
 - Before driving over a workshop hoist, check that the vehicle weight does not exceed the permissible lifting capacity of the hoist.
 - Before driving over a workshop hoist, ensure that there is sufficient clearance between the hoist and low parts of the vehicle. ■





General information

Explanation of technical data

Some of the technical data listed in this manual requires further explanation.

The technical data for your vehicle is listed in the charts starting on ⇒ page 329. This section provides general information, notes and restrictions which apply to this data. ■

Vehicle identification

The key data is given on the vehicle identification number (VIN) plate and the vehicle data sticker.

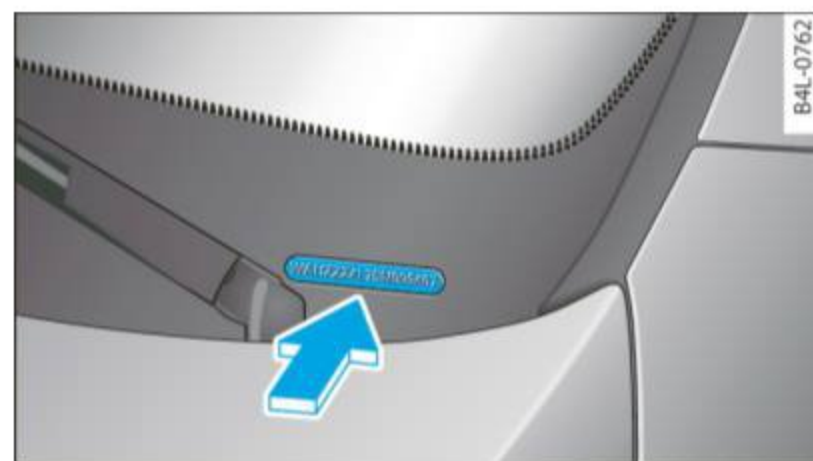


Fig. 240 Vehicle Identification Number (VIN) plate: location on driver's side dash panel

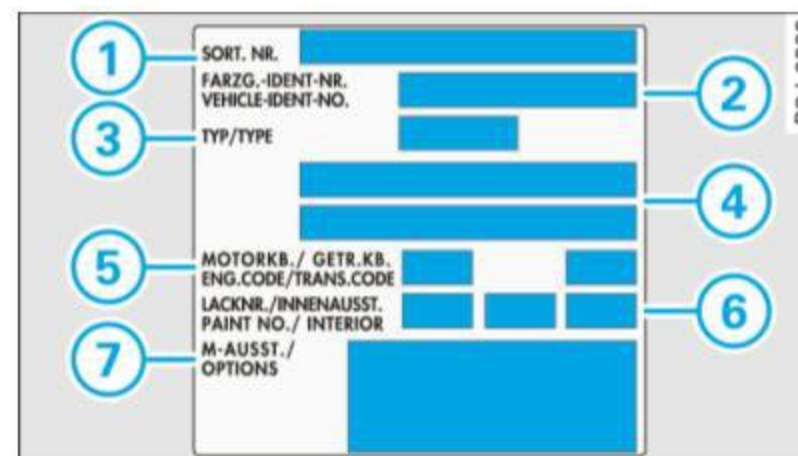


Fig. 241 The vehicle identification label – inside the luggage compartment

The Vehicle Identification Number (VIN)

is located on the driver's side so that it is visible from the outside through the windshield ⇒ fig. 240.

The vehicle identification label

is located in the luggage compartment near the battery.

The label ⇒ fig. 241 shows the following vehicle data:

- ① Production control No.
- ② Vehicle identification No.
- ③ Type code number
- ④ Type designation/engine output in Kilowatts
- ⑤ Engine and transmission code letter
- ⑥ Paint No./Interior
- ⑦ Optional equipment No.'s

Vehicle data 2 to 7 are also found in your Warranty & Maintenance booklet.

The safety compliance sticker

is your assurance that your new vehicle complies with all applicable Federal Motor Vehicle Safety Standards which were in effect at the time the vehicle was manufactured. You can find this sticker on the left door jamb. It shows the month and year of production and the ▶

vehicle identification number of your vehicle (perforation) as well as the Gross Vehicle Weight Rating (GVWR) and the Gross Axle Weight Rating (GAWR).

The high voltage warning label

is located on the lock carrier.

The spark ignition system complies with the Canadian standard ICES-002. ■

Displaying Vehicle Identification Number in the MMI



Fig. 242 MMI display: Vehicle ID number (VIN)

You can also display the Vehicle Identification Number of your vehicle in the MMI.

- Press the **CAR** function button.
- Select **Vehicle ID number (VIN)**. The **Vehicle ID number (VIN)** menu appears ⇒ fig. 242. ■

Weights

Gross Vehicle Weight Rating

The Gross Vehicle Weight Rating (GVWR), and the Gross Axle Weight Rating (GAWR) for front and rear are listed on a sticker on the left door jamb.

The Gross Vehicle Weight Rating includes the weight of the basic vehicle plus full fuel tank, oil and coolant, plus maximum load, which includes passenger weight (150 lbs/68 kg per designated seating position) and luggage weight ⇒ ⚠.

Gross Axle Weight Rating

The Gross Axle Weight Rating is the maximum load that can be applied at each axle of the vehicle ⇒ ⚠.

Vehicle capacity weight

The vehicle capacity weight (max. load) is listed either on the driver's side B-pillar or inside the fuel filler flap.

Roof weight

The maximum permissible roof weight is **165 lb (75 kg)**. The roof weight is made up of the weight of the roof rack system and the weight of the object being transported ⇒ page 93, "Roof load".

⚠ WARNING

- The actual Gross Axle Weight Rating at the front and rear axles should not exceed the permissible weights, and their combination must not exceed the Gross Vehicle Weight Rating.
- Exceeding permissible weight ratings can result in vehicle damage, accidents and personal injury.

ⓘ Note

- The vehicle capacity weight figures apply when the load is distributed evenly in the vehicle (passengers and luggage). When ▶

transporting a heavy load in the luggage compartment, carry the load as near to the rear axle as possible so that the vehicle's handling is not impaired.

- Do not exceed the maximum permissible axle loads or the maximum gross vehicle weight. Always remember that the vehicle's handling will be affected by the extra load. Therefore, adjust your speed accordingly.
- Always observe local regulations. ■

Dimensions

The specifications refer to the basic model. Differences may occur depending on the model type and options ordered, for example, tire sizes.



Note

When driving up steep ramps, on rough roads, over curbs, etc. it is important to remember that some parts of your vehicle, such as spoilers or exhaust system components, may be close to the ground. Be careful not to damage them. ■

Data

265 hp, 6-cylinder engine, with all wheel drive

Engine data

Maximum output SAE net	hp @ rpm	265 @ 6,500
Maximum torque SAE net	lb-ft @ rpm	243 @ 3,000...5,000
No. of cylinders		6 cylinder
Displacement	CID (cm ³)	191 (3,123)
Stroke	in (mm)	3.65 (92.8)
Bore	in (mm)	3.33 (84.5)
Compression ratio		12.5 : 1
Fuel	Premium unleaded (91 AKI) Recommended for maximum engine performance. Further details ⇒ <i>page 253, "Gasoline"</i>	

Dimensions (approx.)

Length (with licence plate bracket)	in (mm)	182.0 (4,625)
Width (with outside mirrors folded)	in (mm)	77.9 (1,981)
Height (unloaded)	in (mm)	54.0 (1,372)
Turning circle diameter (curb to curb)	ft (m)	36.4 (11.1)

Capacities (approx.)

Fuel tank		
- Total capacity	gal (liters)	16.8 (64)
- Reserve (of total capacity)	gal (liters)	2.1 (8)
Windshield and headlight* washer fluid container	quarts (liters)	4.8 (4.5)
Engine oil with filter change	quarts (liters)	6.9 (6.5)

Consumer Information

Warranty coverages

Your Audi is covered by the following warranties:

- *New Vehicle Limited Warranty*
- *Limited Warranty Against Corrosion Perforation*
- *Emissions Control System Warranty*
- *Emissions Performance Warranty*
- *California Emissions Control Warranty (USA vehicles only)*
- *California Emissions Performance Warranty (USA vehicles only)*

Detailed information regarding your warranties can be found in your **Warranty & Maintenance booklet**. ■

Operating your vehicle outside the U.S.A. or Canada

Government regulations in the United States and Canada require that automobiles meet specific emission regulations and safety standards. Therefore, vehicles built for the U.S.A. and Canada differ from vehicles sold in other countries.

If you plan to take your vehicle outside the continental limits of the United States or Canada, there is the possibility that

- unleaded fuels for vehicles with catalytic converter may not be available;
- fuel may have a considerably lower octane rating. Improper fuel may cause engine damage;
- service may be inadequate due to lack of proper service facilities, tools or testing equipment;
- replacement parts may not be readily available.

- Navigation systems for vehicles built for the U.S.A. and Canada will not necessarily work in Europe, and may not work in other countries outside of North America.

Note

Audi cannot be responsible for mechanical damage that could result from inadequate fuel, service or parts availability. ■

Audi Service Repair Manuals and Literature

Audi Official Factory Service Manuals are published as soon as possible after model introduction. Service manuals are available from:

Audi Technical Literature Ordering Center

Call toll-free:

Tel.: 1 (800) 544-8021

(from 8:00 AM to 8:00 PM, EST, Monday through Friday)

or access their website **www.audi.dds1td.com** on the Internet to order repair manuals and other Audi literature. ■

Maintenance

General

Your vehicle has been designed to help keep maintenance requirements to a minimum. However, a certain amount of regular maintenance is still necessary to assure your vehicle's safety, economy and ►

reliability. For detailed vehicle maintenance consult your Warranty & Maintenance booklet.

Under difficult operating conditions, for example at extremely low outside temperatures, in very dusty regions, when towing a trailer very frequently, etc., some service work should be performed between the intervals specified. This applies particularly to:

- oil changes, and
- cleaning or replacing the air filter.



For the sake of the environment

By regularly maintaining your vehicle, you help make sure that emission standards are maintained, thus minimizing adverse effects on the environment. ■

Important considerations for you and your vehicle

The increasing use of electronics, sophisticated fuel injection and emission control systems, and the generally increasing technical complexity of today's automobiles, have steadily reduced the scope of maintenance and repairs which can be carried out by vehicle owners. **Also, safety and environmental** concerns place very strict limits on the nature of repairs and adjustments to engine and transmission parts which an owner can perform.

Maintenance, adjustments and repairs usually require special tools, testing devices and other equipment available to specially trained workshop personnel in order to assure proper performance, reliability and safety of the vehicle and its many systems.

Improper maintenance, adjustments and repairs can impair the operation and reliability of your vehicle and even void your vehicle warranty. Therefore, proof of servicing in accordance with the maintenance schedule may be a condition for upholding a possible warranty claim made within the warranty period.

Above all, operational safety can be adversely affected, creating unnecessary risks for you and your passengers.

If in doubt about any servicing, have it done by your authorized Audi dealer or any other properly equipped and qualified workshop. We strongly urge you to give your authorized Audi dealer the opportunity to perform all scheduled maintenance and necessary repairs. Your dealer has the facilities, original parts and trained specialists to keep your vehicle running properly.


Performing limited maintenance yourself

The following pages describe a limited number of procedures which can be performed on your vehicle with ordinary tools, should the need arise and trained personnel be unavailable. Before performing any of these procedures, always thoroughly read all of the applicable text and carefully follow the instructions given. Always rigorously observe the **WARNINGS** provided.

Before you check anything in the engine compartment, always read and heed all WARNINGS ⇒  **and** ⇒  in "Working in the engine compartment" on page 259.

WARNING

- **Serious personal injury may occur as a result of improperly performed maintenance, adjustments or repairs.**
- **Always be extremely careful when working on the vehicle. Always follow commonly accepted safety practices and general common sense. Never risk personal injury.**
- **Do not attempt any of the maintenance, checks or repairs described on the following pages if you are not fully familiar with these or other procedures with respect to the vehicle, or are uncertain how to proceed.**
- **Do not do any work without the proper tools and equipment. Have the necessary work done by your authorized Audi dealer or another properly equipped and qualified workshop.**

 **WARNING** (continued)

- **The engine compartment of any motor vehicle is a potentially hazardous area. Never reach into the area around or touch the radiator fan. It is temperature controlled and can switch on suddenly - even when the engine is off and the ignition key has been removed. The radiator fan switches on automatically when the coolant reaches a certain temperature and will continue to run until the coolant temperature drops.**
- **Always remove the ignition key before anyone gets under the vehicle.**
- **Always support your vehicle with safety stands if it is necessary to work underneath the vehicle. The jack supplied with the vehicle is not adequate for this purpose and could collapse causing serious personal injury.**
- **If you must work underneath the vehicle with the wheels on the ground, always make sure the vehicle is on level ground, that the wheels are always securely blocked and that the engine cannot be started.**
- **Always make sure the transmission selector lever (automatic transmission) is in "P" (Park position) or Neutral (manual transmission) and the park brake is firmly applied.**

**For the sake of the environment**

- Changing the engine settings will adversely affect emission levels. This is detrimental to the environment and increases fuel consumption.
- Always observe environmental regulations when disposing of old engine oil, used brake fluid, dirty engine coolant, spent batteries or worn out tires.
- Undeployed airbag modules and pretensioners might be classified as Perchlorate Material -special handling may apply, see www.dtsc.ca.gov/hazardouswaste/perchlorate. When the vehicle or parts of the restraint system including airbag modules safety belts with pretensioners are scrapped, all applicable laws and regula-

tions must be observed. Your authorized Audi dealer is familiar with these requirements and we recommend that you have your dealer perform this service for you. ■

Additional accessories, modifications and parts replacement

Additional accessories and parts replacement

Always consult an authorized Audi dealer before purchasing accessories.

Your vehicle incorporates the latest safety design features ensuring a high standard of active and passive safety.

This safety could be compromised by non-approved changes to the vehicle. For this reason, if parts have to be replaced, please observe the following points when installing additional accessories:

Approved Audi accessories and genuine Audi parts are available from authorized Audi dealers.

These dealers also have the necessary facilities, tools and trained specialists to install the parts and accessories properly.

 **WARNING**

Using the wrong spare parts or using non-approved accessories can cause serious personal injury.

- **Use only accessories expressly approved by Audi and genuine Audi spare parts**
- **These parts and accessories have been specially designed to be used on your vehicle.**
- **Never install accessories such as telephone cradles or beverage holders on airbag covers or within the airbag deploy-**

 **WARNING (continued)**

ment zones. Doing so will increase the risk of injury if airbags are triggered in an accident!

- Before you check anything in the engine compartment, always read and heed all WARNINGS ⇒ *page 251*.


 **Note**


- If items other than genuine Audi spare parts, add-on equipment and accessory items are used or if repair work is not performed according to specified methods, this can result in severe damage to your vehicle's engine and body (such as corrosion) and adversely affect your vehicle's warranty.
- If emergency repairs must be performed elsewhere, have the vehicle examined by an authorized Audi dealer as soon as possible.
- The manufacturer cannot be held liable for damage which occurs due to failure to comply with these stipulations. ■

Technical Modifications

Our guidelines must be complied with when technical modifications are made.

Always consult an authorized Audi dealer **before** starting work on any modifications.

This will help ensure that vehicle function, performance and safety are not impaired ⇒ .

Attempting to work on electronic components and the software used with them can cause malfunctions. Because of the way electronic components are interconnected with each other, such malfunctions can also have an adverse affect on other systems that are not directly involved. This means that you risk both a substantial reduction in the operational safety of your vehicle and an increased wear of vehicle parts ⇒ .

Authorized Audi dealers will perform this work in a professional and competent manner or, in special cases, refer you to a professional company that specializes in such modifications.

 **WARNING**

Improper repairs and modifications can change the way vehicle systems work and cause serious personal injury.

 **Note**

If emergency repairs must be performed elsewhere, have the vehicle examined by an authorized Audi dealer as soon as possible. ■





- A**
- A/C mode 104
 - Accessories 332
 - Adaptive light 65
 - defective 39
 - Adding
 - Engine coolant 268
 - Engine oil 264
 - Windshield washer fluid 275
 - Additional accessories 332
 - Additives
 - Engine oil 264
 - Adjusting
 - Steering column manually 108
 - Adjusting front seats 78
 - Advanced key 52
 - Locking and unlocking vehicle 52
 - START ENGINE STOP button ... 111, 112
 - Starting engine 111
 - Switching engine off 112
 - Switching on ignition 111
 - Airbag
 - Warning/indicator lights 17
 - Airbag system 172, 192
 - Advanced Airbag System 176
 - Advanced Airbag System components .. 179
 - Care 186
 - Child restraints 199
 - Children 198
 - Components (front airbags) 179
 - Danger of fitting a child safety seat on the front passenger seat 174
 - Disposal 186
 - Front airbags 176, 177
 - How do the front airbags work? 181
 - How many airbags does my vehicle have? 179
 - How the Advanced Airbag System components work together 180
 - Important safety instructions on the knee airbag system 190
 - Important things to know 172
 - Indicator light 183
 - Knee airbags 188
 - Monitoring 183
 - PASSENGER AIR BAG OFF light 184
 - Repairs 186
 - Safety instructions 185
 - Side airbags 191
 - Side curtain airbags (SIDE GUARD) .. 194
 - Weight-sensing mat 198
 - When must the system be inspected? ... 183
 - All wheel drive 226
 - Alloy wheels 245
 - All-wheel drive
 - Winter tires 292
 - Alternator
 - Malfunction 33
 - Anti-freeze
 - See Engine coolant system 266
 - Anti-glare inside day-night mirror 74
 - Anti-lock brake system
 - How the ABS system works 224
 - Warning/indicator lights 19
 - Anti-Slip Regulation System (ASR)
 - How the system works 222
 - Anti-theft systems
 - Electronic immobilizer 49
 - Ashtray
 - Front 95
 - Rear 95
 - ASR
 - How the Anti-Slip Regulation System works 222
 - Asterisk
 - What does it mean when something is marked with an asterisk? 6
 - Audi Parking System
 - Acoustic parking system tips 144
 - General Information 137
 - Rear, with rear-view camera 137
 - Rear-view camera - parking mode 1 . 141
 - Rear-view camera - parking mode 2 . 142
 - Rear-view camera coverage area 140
 - Safety instructions for the rear-view camera 140
 - Switching rear-view camera on/off .. 144
 - Switching visual display on/off 144
 - Audi Service Repair Manuals and Literature . 330
 - Audi side assist
 - Activating and deactivating 119
 - Description 119
 - Informational and alert stage signals 121

- Messages in instrument cluster display .
126
- MMI settings 125
- Operation 121
- Safety tips 127
- Sensor detection area 121
- Auto Lock 50
- Auto Safety Hotline 161
- Auto-Check Control 31
- Automatic belt retractor 167
- Automatic car wash
See Washing 241
- Automatic climate control plus 99
- A/C mode 104
- See also Deluxe automatic climate control
plus 99
- Automatic driving light control 61
- Automatic Shift Lock (ASL) 132
- Automatic transmission
- 6-speed automatic transmission 129
- Automatic Shift Lock (ASL) 132
- Driving 130
- Dynamic shift program 133
- Emergency release 135
- Fail-safe mode 135
- Kick-down 133
- Manual shift program 134
- Selector lever 131
- Shift buttons 135
- Steering wheel with tiptronic® 135
- Average speed 27
- Avoid damaging the vehicle 231
- ## B
- Battery 270
- Battery location inside the luggage
compartment 271
- Charging 273
- Important warnings when working on the
battery 271
- Jump starting 317
- Low 227
- Replacing the battery 274
- State of charge 227
- Winter operation 270
- Working on the battery 271
- Battery voltage 39
- Before driving 153
- Blended gasoline 253
- Body cavity sealing 246
- Booster seats 205
- How do I properly install a booster seat in
my vehicle? 205
- Safety instructions 205
- Brake assist 225
- Brake booster 224
- Brake fluid
- Changing the brake fluid 270
- Checking the brake fluid level 269
- Reservoir 269
- What is the correct brake fluid level? 269
- What should I do if the brake fluid warning
light comes on? 269
- Brake system 269
- Anti-lock brake system 19
- Brake fluid 269
- Brake fluid specifications for refill and
replacement 270
- Brake light defective 38
- Brake pads 230
- Electromechanical parking brake 113
- General information 223
- How does moisture or road salt affect the
brakes? 223
- Malfunction 33
- Warning/indicator lights 20
- Worn brake pads symbol 38
- Break-in period 229
- Brake pads 230
- Tires 229
- Bulbs 316
- ## C
- California Proposition 65 Warning 260
- Battery specific 272
- Capacities 329
- Car care 240
- Interior 247
- Plastic and vinyl 244
- Weatherstrips 245
- Care of exterior 240
- Cargo area
- See Loading the luggage compartment .
159
- Cargo net 88
- Catalytic converter 230

- Certification 44
 - Changing a flat tire 304
 - Changing a wheel 304
 - Changing engine oil 265
 - Chassis
 - Undercoating 246
 - Checking
 - Engine coolant level 267
 - Checking tire pressure 282
 - Child restraints
 - Danger of using child restraints in the front seat 174
 - What types of child restraint anchors are available? 216
 - Where can I get additional information about child restraints? 216
 - Child safety 197, 202
 - Additional information 213
 - Booster seats 205
 - Convertible child safety seats 203
 - Convertible locking retractor 207
 - Important safety instructions for using child safety seats 200
 - Important things to know when driving with children 197
 - Infant seats 202
 - Installing a child restraint using the LATCH system 212
 - Lower anchorages 211
 - Mounting and releasing the anchorage hook 213
 - Older children and safety belts 207
 - Safety belts and older children 207
 - Tether anchors 213
 - Tether strap 214
 - Which restraint system should my older child wear? 207
 - Child safety seats 202
 - Convertible locking retractor 207
 - Danger of using child restraints in the front seat 174
 - How do I properly install a child safety seat in my vehicle? 200
 - Installing 207
 - LATCH system 212
 - Safety instructions 200
 - Cigarette lighter 96
 - Cleaning
 - Alcantara (synthetic suede) 250
 - Engine compartment 251
 - Fabrics and fabric coverings 247
 - Instrument panel 248
 - Interior 247
 - Leather 249
 - MMI display 247
 - MMI terminal 247
 - Plastic and vinyl 244
 - Plastic parts 248
 - Safety belts 251
 - Trim strips 243
 - trim strips 244
 - Cleaning and protection 240
 - Clock 14
 - Coat hooks 98
 - Cold tire inflation pressure 280
 - Compact spare tire 300
 - See also* Spare tire 300
 - Compass mirror 76
 - Consumer Information 161, 330
 - Contacting NHTSA 161
 - Convenience closed 57
 - Convenience opening 57
 - Convertible child seats
 - How do I properly install a convertible child seat in my vehicle? 203
 - Safety instructions 203
 - Convertible locking retractor
 - Activating 209
 - Deactivating 210
 - Using to secure a child safety seat .. 207, 209
 - Coolant system 266
 - Cooling System
 - Expansion tank 267
 - Cornering light 65
 - Cruise control
 - Changing speed 117
 - Preselect speed 117
 - Switching off 118
 - Switching on 116
 - Warning/indicator lights 19
 - Cruising range 27
 - Cup holders 94
- ## D
- Data 329
 - Data recorder 220
 - Date display 14
 - Daytime running lights 63

- Daytime running lights (Canada) 64
 - Declaration of conformity 44
 - Defective light bulb warning 38
 - Defrosting the windows 104
 - Defrosting windows 104
 - Deluxe automatic climate control plus ... 99
 - Air distribution 103
 - Air vents 105
 - Air vents (rear) 105
 - Automatic mode 101
 - Automatic recirculation 106
 - Basic settings 106
 - Controls 100
 - Defrost 104
 - Description 99
 - Economical use 105
 - Fan 102
 - Front seat heating 107
 - Rear window defogger 104
 - Recirculation mode 103
 - Synchronization 107
 - Temperature 102
 - Turning on and off 101
 - Determining correct load limit 285
 - Digital clock 14
 - Digital compass 76
 - Digital speedometer 24
 - Dimensions 328
 - Dipstick
 - Reading the dipstick properly 263
 - Doors
 - Emergency locking 55
 - Driver information system 22
 - Defective light bulb warning 38
 - Digital speedometer 24
 - Driver information messages 32
 - Open door or rear lid warning 25
 - Outside temperature display 23
 - Sound system display 23
 - Driver seat
 - See Seating position 154
 - Driver's seat memory
 - Activating remote control key 85
 - Driving lights 61
 - Driving messages 32
 - Driving safely 152
 - Driving time 27
 - Duplicate key 46
 - Dust and pollen filter
 - Deluxe automatic climate control plus 99
 - Dust filter
 - Deluxe automatic climate control plus 99
 - DVD player 88
- E**
- Easy entry 81, 83
 - Electrical seat adjustment
 - See Seat adjustment 81
 - Electromechanical parking brake
 - Emergency braking 115
 - Malfunction 116
 - Operation 113
 - Parking 114
 - Releasing and closing 113
 - Starting assist 114
 - Starting from rest 114
 - Starting off with a trailer 115
 - Warning/indicator lights 20
 - Electronic differential lock (EDL)
 - How the system works 221
 - Warning/indicator lights 19
 - Electronic immobilizer 15, 49
 - Electronic power control
 - (EPC) warning/indicator light 17
 - Electronic stabilization program (ESP)
 - How the system works 220
 - Warning/indicator lights 17
 - Emergency braking 115
 - Emergency flasher 66
 - Warning/indicator lights 18
 - Emergency key 46
 - Starting engine 49
 - Emergency locking of the doors 55
 - Emergency release
 - Selector lever 135
 - Emergency starting 317
 - Emergency towing 320
 - Emergency unlocking
 - Ignition key 48
 - Energy management 227
 - Battery power 228
 - Driver notification 228
 - Engine
 - Compartment 260
 - Coolant 266
 - Hood 258
 - Starting 109

- Starting with jumper cables 317
 - Stopping 110
 - Engine compartment
 - Safety instructions 259
 - Working the engine compartment .. 259
 - Engine coolant system 266
 - Adding coolant 268
 - Checking coolant level 267
 - Checking the engine coolant level .. 267
 - Malfunction 34
 - Radiator fan 269
 - Engine coolant temperature
 - Temperature gauge 12
 - Engine data 329
 - Engine hood
 - Closing 259
 - How to release the hood 258
 - Engine oil 261
 - Adding 264
 - Additives 264
 - Changing 265
 - Check oil level 264
 - Checking the engine oil level 263
 - Consumption 264
 - Indications and conditions requiring extra checking 263
 - Oil consumption 262
 - Oil grades 261
 - Recommended oil check intervals .. 263
 - Specification and viscosity 261
 - Engine oil level 39
 - Engine oil pressure
 - Malfunction 35
 - Engine oil sensor defective 39
 - Environment
 - Break-in period 229
 - Catalytic converter 230
 - Disposing of your vehicle battery ... 274
 - Driving at high speeds 231
 - Driving to minimize pollution and noise . 231
 - Fuel 255
 - Fuel economy 231
 - Leaks under your vehicle 259
 - Letting the vehicle stand and warm up .. 232
 - Proper disposal of drained brake fluid ... 270
 - Proper disposal of drained engine coolant 268
 - Proper disposal of drained engine oil ... 264, 265
 - Recycling used engine oil 264
 - Unleaded fuel 253
 - What should I do with an old battery? ... 274
 - Environmental note
 - Rear window defogger 104
 - Roof rack 93
 - EPC
 - See Electronic power control 17
 - ESP
 - See Electronic stabilization program (ESP) 17
 - Event Data Recorder (EDR) 220
 - Expansion tank 267
 - Eyeglasses compartment 98
- ## F
- Fan
 - Deluxe automatic climate control plus ... 102
 - Radiator 269
 - Flat tire
 - Changing 304
 - Floor mats 159
 - Fog lights 62
 - Foot pedals 158
 - For the sake of the environment
 - Gasoline fumes and the environment 255
 - Reducing engine noise by early upshifting 13
 - Refueling 255
 - Saving fuel by early upshifting 13
 - Front airbags
 - Description 176
 - How they work 181
 - Front arm rest
 - Adjusting 86
 - Storage compartment 86
 - Front ashtray 95
 - Front seats 78
 - Adjusting 155
 - Child restraints in the front seat 174
 - Frontal collisions and the laws of physics ... 164
 - Fuel
 - Additives 253
 - Blended gasoline 253
 - Consumption 27

- Filler neck 254
 Fuel gauge 14
 Gasoline 253
 Gasoline additives 254
 Octane rating 253
 Recommendation 253
 Refuelling 255
 Reserve 14
 Tank capacity 329
 Unlocking the fuel filler flap by hand 257
 Fuel filler flap
 Unlocking the fuel filler flap by hand 257
 Fuel supply too low 38
 Fuse arrangement 312
- G**
- Garage door opener (HomeLink®) 145
 Gas discharge lamps 316
 Gauges
 Engine coolant temperature 12
 Fuel gauge 14
 Speedometer 13
 Gearshift indicator 24
 Gearshift lever
 6-speed manual transmission 129
 General illustration
 Instruments and controls 11
 Glossary of tire and loading terminology ...
 277
 Glove compartment 97
 Gross Vehicle Weight Rating (GVWR) ... 327
- H**
- Head lights
 Fog lights 62
 Rear fog lights 62
 Head restraints 157
 Adjusting 157
 Front seats 85
 Rear seats 86
 Headlight washer reservoir 275
 Headlights
 Adaptive light 65
 Headlight range control defective 39
 Washer system 71
 Heatable
 Front seats (deluxe automatic climate control plus) 107
 Heated
 Rear window 104
 Heated outside mirrors 75
 Heated washer jets
 Wiper and washer system 70
 Heating
 Deluxe automatic climate control plus 99
 Heavy clothing and safety belts 166
 High beam 66
 Warning/indicator lights 18
 High voltage warning label 326
 HomeLink® universal remote control ... 145
 Hood
 Opening 258
 Release lever 258
 Horn 11
- How many airbags does my vehicle have? ..
 179
 How often should I check my tire pressures?
 283
 How safety belt pretensioners work 170
 Hydroplaning 287
- I**
- Ignition key 109
 Emergency unlocking 48
 Ignition lock 109
 Malfunction 36, 39
 Immobilizer 15, 46
 Important things to do before driving .. 153
 Improperly worn safety belts 170
 Indicator lights 16
 Airbag system 183, 184
 PASSENGER AIR BAG OFF 184
 Infant seats 202
 How do I properly install an infant seat in
 my vehicle? 202
 Safety instructions 202
 Inside rear view mirror 74
 Installing child safety seats
 Safety belts 207
 Instrument lighting 64
 Instruments and controls 12
 General illustration 11
 Interior lights
 Dimming 67
 Front 67
 Rear 68

- J**
- Jumper cables 318
 - Jump-starting 317
- K**
- Key 46
 - Battery replacement 47
 - Key replacement 46
 - Master key with remote control 46
 - Mechanical key 48
 - Kick-down
 - tiptronic® 133
 - Knee airbags 188
 - Description 188
 - How they work 189
 - Important safety instructions 190
- L**
- LATCH 211
 - Description 211
 - Installing a child restraint 212
 - Location 211
 - Mounting and releasing the anchorage
 - hook 213
 - Leather 248
 - Cleaning 249
 - Lifting jack 307
 - Lifting vehicle 322
 - Light
 - Coming home 63
 - Daytime running lights 63
 - Driving light control 61
 - Exterior lighting 63
 - Leaving home 63
 - Switching on and off 61
 - Light sensor 61
 - Light sensor defective 38
 - Lighting 61
 - Lights
 - Emergency flashers 66
 - High beam 66
 - High beam warning/indicator light ... 18
 - Turn signals 66
 - Xenon headlights 65
 - Loading the luggage compartment 159
 - Locking
 - Power locking switch 54
 - Rear lid/trunk lid 55
 - Remote control key 51
 - Using the mechanical key 53
 - Low beams 61
 - Low-beam headlight
 - Defective 38
 - Lower anchorage locator button 211
 - Lower universal anchorage bars (Canada) ... 211
 - Lower universal anchorages (Canada) .. 211
 - Luggage
 - Stowing 159
 - Luggage compartment 87
 - Cargo net 88
 - Enlarging 89, 90
 - enlarging 90
 - Loading 87
 - Pass through 91
 - Side storage 88
 - Tie-down eyelets 87
 - Trunk pass-through 92
 - See also* Loading the luggage
 - compartment 159
 - See also* Luggage compartment 87
- M**
- Maintenance 330
 - Malfunction Indicator Lamp (MIL) 18, 26
 - Manual transmission 129
 - Master key
 - Battery replacement 47
 - Check light 47
 - Master key with remote control 46
 - Mechanical emergency closing function
 - Panorama roof 60
 - Mechanical key 48
 - Memory for driver's seat 83
 - Recalling settings 84
 - Storing settings 84
 - Mileage
 - Average 27
 - Instantaneous 27
 - Mirrors
 - Activating the digital compass 76
 - Adjusting the anti-glare 74
 - Automatic dimming for the outside
 - mirrors 76
 - Automatically dimming inside mirror . 74
 - Inside rearview mirror 73

- Interior mirror 74
 - Manual glare dimming 73
 - Outside mirrors 75
 - Monitoring the Advanced Airbag System ..
183
- ## N
- Natural leather 248
 - New tires and wheels 288
 - NHTSA
 - Contacting 161
 - Number of seats 163
- ## O
- Occupant seating positions 154
 - Octane rating 253
 - Odometer 15
 - Oil
 - See Engine oil 261, 264
 - Oil consumption 264
 - Older children and safety belts 207
 - On-Board Diagnostic System (OBD)
 - Data Link Connector (DLC) 26
 - Electronic speed limiter 27
 - Malfunction Indicator Lamp (MIL) 26
 - Open door or rear lid warning 25
 - Operate your vehicle economically and mini-
mize pollution 231
 - Optional equipment
 - Marked with an asterisk 6
 - Outside mirrors 75
 - Outside temperature display 23
 - Owner's manual
 - How the Owner's Manual is organized . 6
- ## P
- Paint
 - Touch-up 244
 - Paint No. 326
 - Panorama roof 59
 - Mechanical emergency closing function
60
 - Tilting and closing 59
 - Panorama sunroof
 - Convenience opening/closing 57
 - Park assist 137
 - Parking 114
 - Automatic transmission 130
 - Valet parking 58
 - Parking brake 113
 - See also Electromechanical parking brake
113
 - Parking lights 61
 - Parts replacement 332
 - Pass through 91
 - PASSENGER AIR BAG OFF light 184
 - Passive safety system 152
 - Pedals 158
 - Physical principles of a frontal collision . 164
 - Polishing 243
 - Power locking switch 54
 - Power locking system 49
 - Emergency locking 55
 - Locking and unlocking the vehicle from
inside 54
 - Rear lid/trunk lid 55
 - Selective unlock feature 51
 - Settings 51
 - Unlocking and locking vehicle 51
 - Power locks
 - Windows open and closed 57
 - Power steering 225
 - Power window regulators
 - Convenience opening/closing 57
 - Malfunctions 58
 - Power window switches 56
 - Pregnant women
 - Special considerations when wearing a
safety belt 169
 - Programming the HomeLink® universal re-
mote control 145
 - Proper occupant seating positions 154
 - Proper safety belt position 168
 - Proper seating position
 - Front passenger 155
 - Occupants 154
 - Rear passengers 156
- ## Q
- Quartz clock 14
 - Question
 - What happens to unbelted occupants? ..
165
 - Why safety belts? 163

- R**
- Radiator fan 269
 - Rain sensor defective 38
 - Reading lights
 - Front 67
 - Rear 68
 - Rear ashtray 95
 - Rear fog lights 62
 - Rear lid
 - Escape handle 298
 - Opening and closing 55
 - Rear light
 - Defective 38
 - Rear View
 - See Rear-view camera 137
 - Rear view mirror
 - Inside rear view mirror 74
 - Rear window defogger 104
 - Rear window shade 69
 - Rear-view camera 137
 - Parking mode 1 141
 - Parking mode 2 142
 - Rearview mirror
 - See Mirrors 73
 - Recirculation mode
 - Deluxe automatic climate control plus ...
103
 - Red symbols 32
 - Refill engine oil 35
 - Refuelling 255
 - Release lever for hood 258
 - Remote control garage door opener
(HomeLink®) 145
 - Remote control key
 - Unlocking and locking 51
 - Remote rear lid release 55
 - Repair manuals 330
 - Repairs
 - Airbag system 186
 - Replacing
 - Wheel rims 290
 - Replacing a fuse 312
 - Replacing bulbs 316
 - Replacing tires and wheels 288
 - Reporting Safety Defects 161, 162
 - Reset button 15
 - Retractor 167
 - Rims
 - Cast alloy 245
 - Replacing 290
 - Roof luggage rack
 - Mounting points 93
 - Roof rack 92
 - Roof load 93
 - See also Roof luggage rack 92
- S**
- SAFE 15
 - Safe driving habits 152
 - Safety belt position 168
 - Safety belts worn by pregnant women ..
169
 - Safety belt pretensioner 170
 - Service and disposal 171
 - Safety belt warning light 18, 163
 - Safety belts 167
 - cleaning 251
 - Danger to passengers who do not wear a
safety belt 165
 - Fastening 167
 - Improperly worn 170
 - Not worn 165
 - Safety belt position 168
 - Safety instructions 166
 - Securing child safety seats 207
 - Special considerations for pregnant
women 169
 - Unfastening 170
 - Warning/indicator light 163
 - Why YOU MUST wear them 163
 - Worn properly 166
 - Safety compliance sticker 326
 - Safety equipment 152
 - Safety features for occupant restraint and
protection 152
 - Safety guidelines
 - Seat adjustment 78
 - Safety instructions
 - Engine compartment 259
 - for booster seats 205
 - for side curtain airbags 195
 - for using child safety seats 200
 - for using convertible child seats 203
 - for using infant seats 202

- for using safety belts 166
 - Monitoring the Advanced Airbag System
185
 - Seat adjustment
 - Driver's seat 78
 - Easy entry 83
 - Easy entry manual 81
 - For-and-aft manually 80
 - Front passenger's seat 79
 - Front seats 78
 - Head restraints 157
 - Manual 79
 - Power 81
 - Seat back angle manually 80
 - Seat height manually 80
 - Seat belts
 - See Safety belts 163
 - Seat heating
 - Front (deluxe automatic climate control
plus) 107
 - Seat memory 83
 - Seat ventilation 107
 - Seating capacity 163
 - Seating position
 - Driver 154
 - Front passenger 155
 - How to adjust the front seats 155
 - Incorrect seat position 157
 - Occupants 154
 - Rear passengers 156
 - Seats
 - Number of seats 163
 - Selective unlock feature 51
 - Selector lever 131
 - Emergency release 135
 - Service and disposal
 - Safety belt pretensioner 171
 - Service interval display 25
 - Service position for windshield wipers .. 72
 - Servotronic
 - Power steering 225
 - SET button 13
 - Shift buttons 135
 - Side airbags
 - Description 191
 - How they work 192
 - Side curtain airbags (SIDEGUARD) 194
 - Description 194
 - How they work 195
 - Safety instructions 195
 - Ski sack
 - See Trunk pass-through 92
 - Snow chains 293
 - Sockets 96
 - Sound system display
 - Driver information display 23
 - Spare tire 300
 - Speed rating letter code 289
 - Speed warning system 30
 - Speedometer 13, 15
 - Starting engine
 - Emergency key 49
 - Starting from rest 114
 - Starting off with a trailer 115
 - Starting the engine 109
 - Steering
 - Locking the steering 109
 - Malfunction 36
 - Manually adjusting the steering wheel ..
108
 - Steering wheel column
 - Adjusting manually 108
 - Steps for determining correct load limit 285
 - Stopping the engine 110
 - Storage 97
 - Front seats 98
 - Glove compartment 97
 - Storage net 88
 - Sun shade 69
 - Sun visors 68
 - Switches
 - Emergency flashers 66
 - Symbols
 - Red 32
 - Yellow 36
- ## T
- Technical modifications 333
 - Tether strap 214
 - Securing the upper tether strap 215
 - The first 1,000 miles (1,500 km) and
afterwards 229
 - Tie-down eyelets 87
 - Tie-downs 87, 161
 - tiptronic® 129
 - Automatic Shift Lock (ASL) 132
 - Driving 130

- Dynamic shift program 133
 - Fail-safe mode 135
 - Kick-down 133
 - Manual shift program 134
 - Selector lever 131
 - Tire mobility system 299, 301
 - Tire pressure 282
 - Tire pressure monitoring system 40
 - Changing wheels 43
 - Declaration of conformity 44
 - Learning process 42
 - Loss of air pressure 18, 42
 - Malfunctions 44
 - Sensors 290
 - Storing tire pressures 42
 - Tires and wheels 290
 - Valves 290
 - Tire repair kit 299, 301
 - Tire service life 286
 - Tires 276
 - Replacing 290
 - Service life 286
 - speed rating letter code 289
 - Tire manufacturing date 289
 - Tire specifications 289
 - Tread depth 286
 - Uniform tire quality grading 292
 - Winter tires 292
 - Tires and vehicle load limits 284
 - Tires and wheels
 - Checking tire pressure 282
 - Cold tire inflation pressure 280
 - Dimensions 288
 - General notes 276
 - Glossary of tire and loading terminology .
277
 - New tires and wheels 288
 - Replacing 288
 - Snow chains 293
 - Tire pressure monitoring system ... 290
 - Tires and vehicle load limits 284
 - Wheel bolts 294
 - Winter tires 292
 - Tires/Wheels
 - Low aspect ratio tires 295
 - Tire mobility system 301
 - Tire pressure monitoring system . 18, 40
 - Tire repair kit 301
 - Tool kit 298
 - Torn or frayed safety belts 166
 - Touch-up paint 244
 - Towing
 - Front eyelet 320
 - Rear eyelet 321
 - Tow truck procedures 320
 - Trailer towing 234
 - Operating instructions 234
 - Technical requirements 234, 235
 - Trailer towing tips 236
 - Transmission
 - 6-speed manual transmission 129
 - tiptronic® 129
 - Transport Canada 162
 - Tread Wear Indicator (TWI) 286
 - General notes 276
 - Glossary of tire and loading terminology .
277
 - New tires and wheels 288
 - Replacing 288
 - Snow chains 293
 - Tire pressure monitoring system ... 290
 - Tires and vehicle load limits 284
 - Wheel bolts 294
 - Winter tires 292
 - Tires/Wheels
 - Low aspect ratio tires 295
 - Tire mobility system 301
 - Tire pressure monitoring system . 18, 40
 - Tire repair kit 301
 - Tool kit 298
 - Torn or frayed safety belts 166
 - Touch-up paint 244
 - Towing
 - Front eyelet 320
 - Rear eyelet 321
 - Tow truck procedures 320
 - Trailer towing 234
 - Operating instructions 234
 - Technical requirements 234, 235
 - Trailer towing tips 236
 - Transmission
 - 6-speed manual transmission 129
 - tiptronic® 129
 - Transport Canada 162
 - Tread Wear Indicator (TWI) 286
 - Trip computer
 - Fuel consumption 27
 - Mileage 27
 - Single-trip memory 28
 - Total-trip memory 28
 - Trip odometer 15
 - Trunk
 - See Rear lid 55
 - Trunk escape handle 298
 - Trunk pass-through 92
 - Turn signals 66
 - Warning/indicator lights 18
- ## U
- Undercoating 246
 - Unfastening safety belts 170
 - Unidirectional tires 276
 - Uniform tire quality grading 292
 - Unlocking
 - Power locking switch 54
 - Rear lid/trunk lid 55
 - Remote control key 51
 - Using the mechanical key 53
 - Use of jumper cables 318
- ## V
- Valet parking 58
 - Vanity mirror 68
 - Vehicle Identification Number (VIN) 326
 - Vehicle jack 307
 - Vehicle literature 5

- Vehicle tool kit 298
- Vehicle-care products 240
- Ventilation
- Deluxe automatic climate control plus 99
- W**
- Warning lights 16
- Warning/indicator lights 12
- Airbag system 17
 - Anti-lock brake system (ABS) 19
 - Brake system 20
 - Cruise control 19
 - Electromechanical parking brake 20
 - Electronic power control 17
 - Electronic stabilization program (ESP) 17
 - High beam 18
 - Malfunction Indicator Lamp (MIL) 18
 - Safety belt 18
 - Tire pressure monitoring system 18
 - Turn signals 18
- Warranty coverages 330
- Washer reservoir 275
- Washing 240
- Automatic car wash 241
 - by hand 241
 - General information 240
 - with a power washer 242
- Waxing 243
- Wear indicator 286
- Weatherstrips 245
- Weights 327
- What happens if you wear your safety belt too loose? 168
- What happens to unbelted occupants? . 165
- What impairs driving safety? 153
- What should I do after changing a wheel? .. 283
- What should I do after replacing wheels? .. 283
- Wheel bolts
- Torque 294
- Wheels 276
- Cast alloy 245
 - Checking tire pressure 282
 - Cold tire inflation pressure 280
 - General notes 276
 - Glossary of tire and loading terminology 277
 - New tires and wheels 288
 - Tires and vehicle load limits 284
- When must a safety belt be replaced? .. 166
- When must the airbag system be inspected? 183
- When should I adjust the tire pressures? ... 283
- When should I check the tire pressures? 283
- Where can I find the tire pressures for my car? 282
- Why safety belts? 163, 164
- Window regulators
- Malfunctions 58
 - Power locks 57
- Windows
- Cleaning 244
- Windshield defogging/defrosting 104
- Windshield washer fluid
- Low level 38
- Windshield wiper
- Installing new wiper blades 73
- Windshield wipers
- Faulty 40
 - Service position 72
 - Washer reservoir 275
- Winter operation
- Battery 270
 - Coolant system 266
 - Defrosting windows 104
 - Seat heating (deluxe automatic climate control plus) 107
 - Tires 226
 - Windows 244
- Winter tires 292
- All-wheel drive 292
- Wiper and washer system 70
- Intermittent wiping 70
 - One-tap wiping 70
- Wiper blades
- Installing new wiper blades 73
- X**
- Xenon headlights 65
- Xenon-Lights 316
- Y**
- Yellow symbols 36

It has always been Audi's policy to continuously improve its products. Audi, therefore, reserves the right to make changes in design and specifications, and to make additions or improvements in its products, without incurring any obligation to install them on products previously manufactured.

Text, illustrations and specifications in this manual are based on the most up-to-date information available at the time of printing.

All rights reserved. May not be reproduced or translated in whole or in part without the written consent of AUDI AG. Specifications are subject to change without notice.

"Audi", "quattro" and the four rings emblem are registered trademarks of AUDI AG. "A5" is trademark of AUDI AG.

Editorial deadline: 6/30/2007



For the sake of the environment

Printed on environmentally friendly paper (bleached without chlorine, recyclable).

Printed in Germany

© 2007 AUDI AG

www.audi.com

2008 Audi A5
Owner's Manual
Englisch USA 7.07
281.561.8T3.23