



M3 convertible

Thank you for deciding on a BMW M3 convertible.

Thorough familiarity with your vehicle will provide you with enhanced control and security when you drive it. Therefore, we have one request:

Read the information contained in this Owner's Manual before driving your new BMW M3 convertible for the first time. It contains important information on vehicle operation that will enable you to make full use of the advanced technical equipment of your BMW M3 convertible. In addition, you will receive information on vehicle maintenance to help ensure operating and traffic safety as well as the best possible value retention of your BMW.

For more detailed information refer to the Supplemental Manuals.

BMW M also makes decisive contributions toward greater safety in traffic through its BMW driver training.

This Owner's Manual should be considered a permanent part of this vehicle. It should stay with the vehicle when sold to provide the next owner with important operating, safety and maintenance information.

We wish you an enjoyable driving experience.

BMW M

About this Owner's Manual

We have made every effort to ensure that you are able to find what you need in this Owner's Manual as quickly as possible. The fastest way to find certain topics is by using the detailed index at the end. If you wish to gain an initial overview of your vehicle, you will find this in the first chapter.

Should you wish to sell your BMW at some time in the future, please remember to hand over this Owner's Manual to the new owner; it is an important part of the vehicle.

Should you have any further questions, your BMW center will be glad to assist at any time.

© 2002 BMW M GmbH
Munich, Germany

Reprinting, including excerpts, only with the written consent of BMW M GmbH, Munich.

Order No. 01 41 0 156 854

US English VIII/02

Printed in Germany

Printed on environmentally friendly paper – bleached without chlorine, suitable for recycling.

Symbols used



Indicates precautions that must be followed precisely in order to avoid the possibility of personal injury and serious damage to the vehicle.



Contains information that will assist you in gaining the optimum benefit from your vehicle and enable you to care more effectively for your vehicle.



Refers to measures that can be taken to help protect the environment.

◀ Marks the end of a specific item of information.

* Indicates special equipment, country-specific equipment and optional extras.



Identifies systems or components which can be activated or adapted to suit an individual driver's requirements – Vehicle Memory, Key Memory. Refer to page 65. Activation and adjustments on some of these systems can be performed at your BMW center. ▶

Your individual vehicle

On purchasing your BMW, you have decided in favor of a model with individualized equipment and features. This Owner's Manual will describe all of the equipment that the BMW M3 convertible has to offer you.

We hope you will understand that equipment and features are included that you might not have chosen for your vehicle. You can easily identify any differences with the aid of the asterisk * used to identify all optional equipment and accessories.

If your BMW features equipment that is not described in this Owner's Manual, such as a car radio or telephone, we have enclosed Supplementary Owner's Manuals. We ask you to read these manuals as well.

Status at time of printing

BMW pursues a policy of continuous, ongoing development that is conceived to ensure that our vehicles continue to embody the highest quality and safety standards combined with advanced, state-of-the-art technology. For this reason, the features described in this Owner's Manual could differ from those on your vehicle. Nor can errors and omissions be entirely ruled out. You are therefore asked to appreciate that no claims can be recognized on the basis of the data, illustrations or descriptions in this Owner's Manual.

For your own safety



Use unleaded gasoline only. Fuels containing up to and including 10% ethanol or other oxygenates with up to 2.8% oxygen by weight – that is, 15% MTBE or 3% methanol plus an equivalent amount of co-solvent – will not void the applicable warranties respecting defects in materials or workmanship. Field experience has indicated significant differences in fuel quality – volatility, composition, additives, etc. – among gasolines offered for sale in the United States and Canada. The use of poor quality fuels may result in driveability, starting and stalling problems especially under certain environmental conditions, such as high ambient temperature and high altitude. Should you encounter driveability problems which you suspect could be related to the fuel you are using, we recommend that you respond by switching to a recognized high-quality brand.

Failure to comply with these recommendations may result in unscheduled maintenance.

Obey pertinent safety rules when you are handling gasoline. ◀



Important safety information!

For your own safety, use genuine parts and accessories approved by BMW. When you purchase accessories tested and approved by BMW and Original BMW Parts, you simultaneously acquire the assurance that they have been thoroughly tested by BMW to ensure optimum performance when installed on your vehicle.

BMW warrants these parts to be free from defects in material and workmanship.

BMW will not accept any liability for damages resulting from installation of parts and accessories not approved by BMW.

BMW cannot test every product made by other manufacturers to verify if it can be used on a BMW safely and without risk to either the vehicle, its operation, or its occupants.

Original BMW Parts, BMW Accessories and other products approved by BMW, together with professional advice on using these items, are available from all BMW centers.

Installation and operation of non-BMW approved accessories such as alarms, radios, amplifiers, radar detectors, wheels, suspension components, brake

6 Notes

dust shields, telephones – including operation of any portable cellular phone from within the vehicle without using an externally mounted antenna – or transceiver equipment, such as CB, walkie-talkie, ham radio or similar, may cause extensive damage to the vehicle, compromise its safety, interfere with the vehicle's electrical system or affect the validity of the BMW Limited Warranty. Contact your BMW center for additional information. Do not use key or remote control to lock doors or luggage compartment with anyone inside the vehicle. Refer to the Owner's Manual for more details. ◀



Maintenance, replacement, or repair of the emission control devices and systems may be performed by any automotive repair establishment or individual using any certified automotive part. ◀

Symbol on vehicle parts



Indicates that you should consult the relevant section of this Owner's Manual for information on a particular part or assembly.

Service and warranty

This manual is supplemented by a Service and Warranty Information Booklet for US models or a Warranty and Service Guide Booklet for Canadian models.

We recommend that you read this publication thoroughly.

Your BMW is covered by the following warranties:

- ▷ New Vehicle Limited Warranty
- ▷ Rust Perforation Limited Warranty
- ▷ Federal Emissions System Defect Warranty
- ▷ Federal Emissions Performance Warranty
- ▷ California Emission Control System Limited Warranty.

Detailed information about these warranties is listed in the Service and Warranty Information Booklet for US models or in the Warranty and Service Guide Booklet for Canadian models.

Reporting safety defects

The following only applies to vehicles owned and operated in the US.

If you believe that your vehicle has a defect which could cause a crash or could cause injury or death, you should immediately inform the National Highway Traffic Safety Administration NHTSA in addition to notifying BMW of North America, LLC, P.O. Box 1227, Westwood, New Jersey 07675-1227, Telephone toll-free 1-800-831-1117.

If NHTSA receives similar complaints, it may open an investigation, and if it finds that a safety defect exists in a group of vehicles, it may order a recall and remedy campaign. However, NHTSA cannot become involved in individual problems between you, your dealer, or BMW of North America, LLC.

To contact NHTSA, you may either call the Auto Safety Hotline toll-free at 1-800-424-9393 or 366-0123 in the Washington, D.C. area, or write to: NHTSA, U.S. Department of Transportation, Washington, D.C. 20590. You can also obtain other information about motor vehicle safety from the Hotline.

Contents

Notes	About this Owner's Manual	4
	Symbols used	4
	Your individual vehicle	4
	Status at time of printing	5
	For your own safety	5
	Symbol on vehicle parts	6
	Service and warranty	6
	Reporting safety defects	6

Overview	Cockpit	14
	Instrument cluster	16
	Indicator and warning lamps	18
	Steering wheel with multifunction buttons	22
	Hazard warning triangle*	23
	First-aid kit*	23
	Refueling	24
	Fuel specifications	25
	Tire inflation pressure	25

Controls and features	Opening and closing:	
	Keys	30
	Central locking system	30
	Opening and closing – via the remote control	31
	Opening and closing – via the door lock	33
	Opening and closing – from the inside	34
	Luggage compartment lid	35
	Luggage compartment	37
	Alarm system*	38
	Electric power windows	40
	Convertible top	41
	Wind deflector*	46
	To adjust:	
	Safe seating position	48
	Seats	49
	Power seat adjustment	49
	Head restraints	50
	Entering the rear	51
	Safety belts	52
	Seat and mirror memory	53
	Seat heating*	54
	Steering wheel	55
	Mirrors	55

Contents

Controls and features	Passenger safety systems:	Technology for safety and driving convenience:	Operation, maintenance	Special operating instructions:
	Airbags 57	Park Distance Control (PDC)* 86		Break-in procedures 110
	Transporting children safely 59	Dynamic Stability Control (DSC) 87		Driving notes 111
	Rollover protection system 63	Flat Tire Monitor 88		Antilock Brake System (ABS) 111
	Vehicle Memory, Key Memory 65	M Engine dynamics control 91		Brake system 112
	Driving:	Lamps:		Hardtop* 113
	Ignition lock 66	Parking lamps/Low beams 92		Wheels and tires:
	Starting engine and driving off 67	Instrument lighting 93		Tire inflation pressure 115
	Switching off the engine 69	High beams/Standing lamps 93		Tire condition 115
	Parking brake 69	Fog lamps 94		Tire replacement 116
Manual transmission 70	Interior lamps 94	Wheel and tire combinations 118		
Sequential M gearbox SMG II* 71	Reading lamps 94	Winter tires 118		
Turn signal indicator/Headlamp flasher 76	Controlling the climate for pleasant driving:	Snow chains* 119		
Washer/wiper system/Rain sensor* 77	Automatic climate control 96	In the engine compartment:		
Cruise control 78	Interior conveniences:	Hood 120		
Everything under control:	Glove compartment 101	Engine compartment essentials 122		
Odometer 80	Storage compartments 101	Washer fluids 124		
Tachometer 80	Cellular phone* 102	Engine oil 124		
Temperature gauge 80	Ashtray, front* 102	Coolant 126		
Fuel gauge 81	Ashtray, rear* 103	Brake fluid 127		
Engine coolant temperature gauge 81	Loading and transporting:	Maintenance:		
Service interval display 82	Ski bag* 104	The BMW Maintenance System 128		
Check Control 82	Cargo loading 106	Laws and regulations:		
Clock 83	Roof-mounted luggage rack for the hardtop* 107	California Proposition 65 warning 130		
Computer 84		OBD interface socket 130		

Contents

Owner service procedures

Replacement procedures:

- Onboard tool kit 134
- Windshield wiper blades 134
- Lamps and bulbs 135
- Repairing a flat tire 139
- Battery 143
- Fuses 144

Giving and receiving assistance:

- Jump-starting 145
- Towing the vehicle 146

Technical data

- Engine data 150
- Dimensions 151
- Weights 152
- Capacities 153

Index

- Everything from A to Z 156





Overview

Controls and features

Operation, maintenance

Owner service procedures

Technical data

Index



14 Cockpit

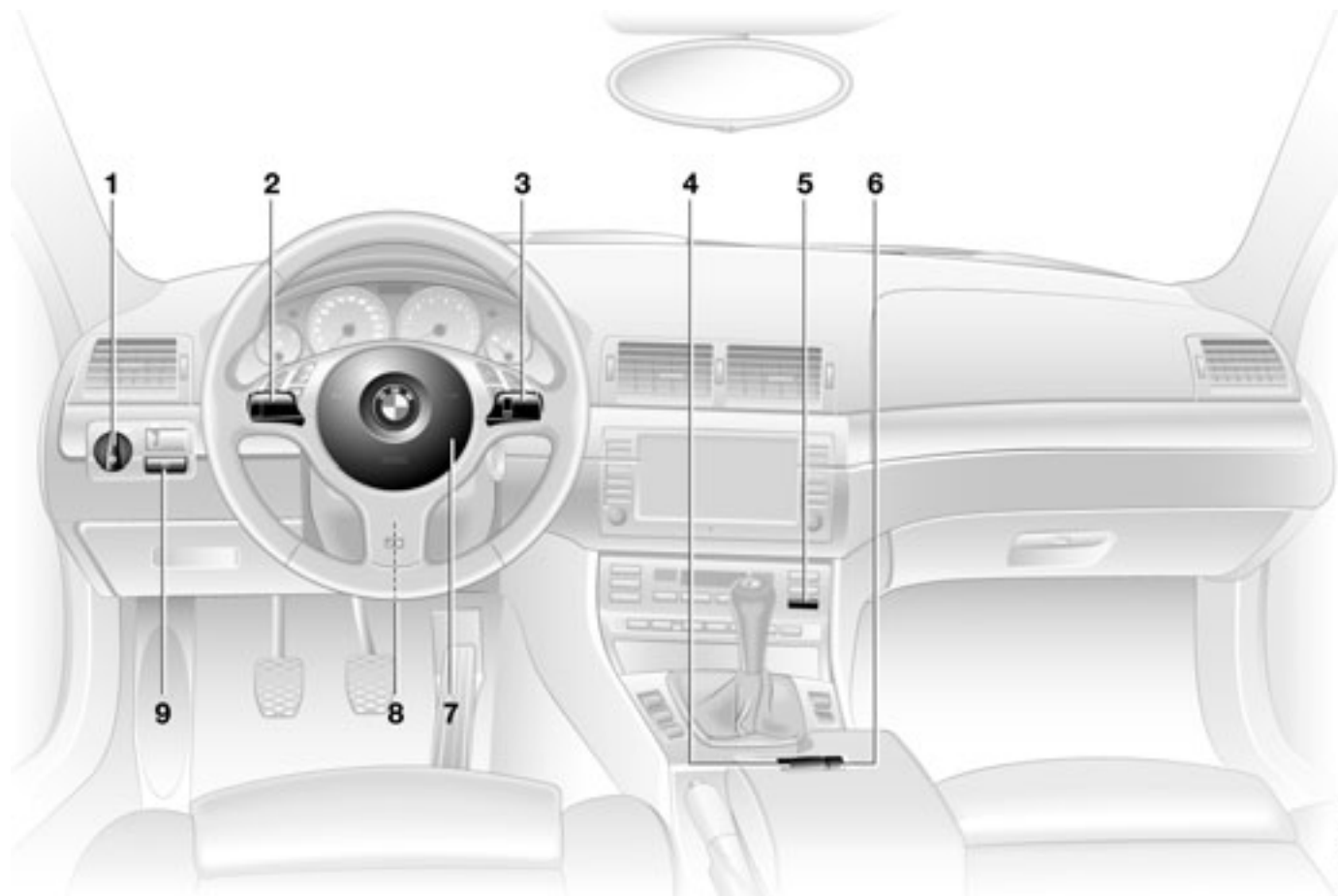

Cockpit

- 1 Parking lamps/Low beams 92
- 2 ▷ Turn signal indicators 76
 - ▷ Standing lamps 93
 - ▷ High beams 93
 - ▷ Headlamp flasher 76
 - ▷ Computer 84
- 3 Washer/wiper system/Rain sensor 77
- 4 Hazard warning flashers
- 5 Rear window defroster 99
- 6 Central locking system 30
- 7 Horn: the entire surface
- 8 Steering wheel 55
- 9 Fog lamps 94

16 Instrument cluster

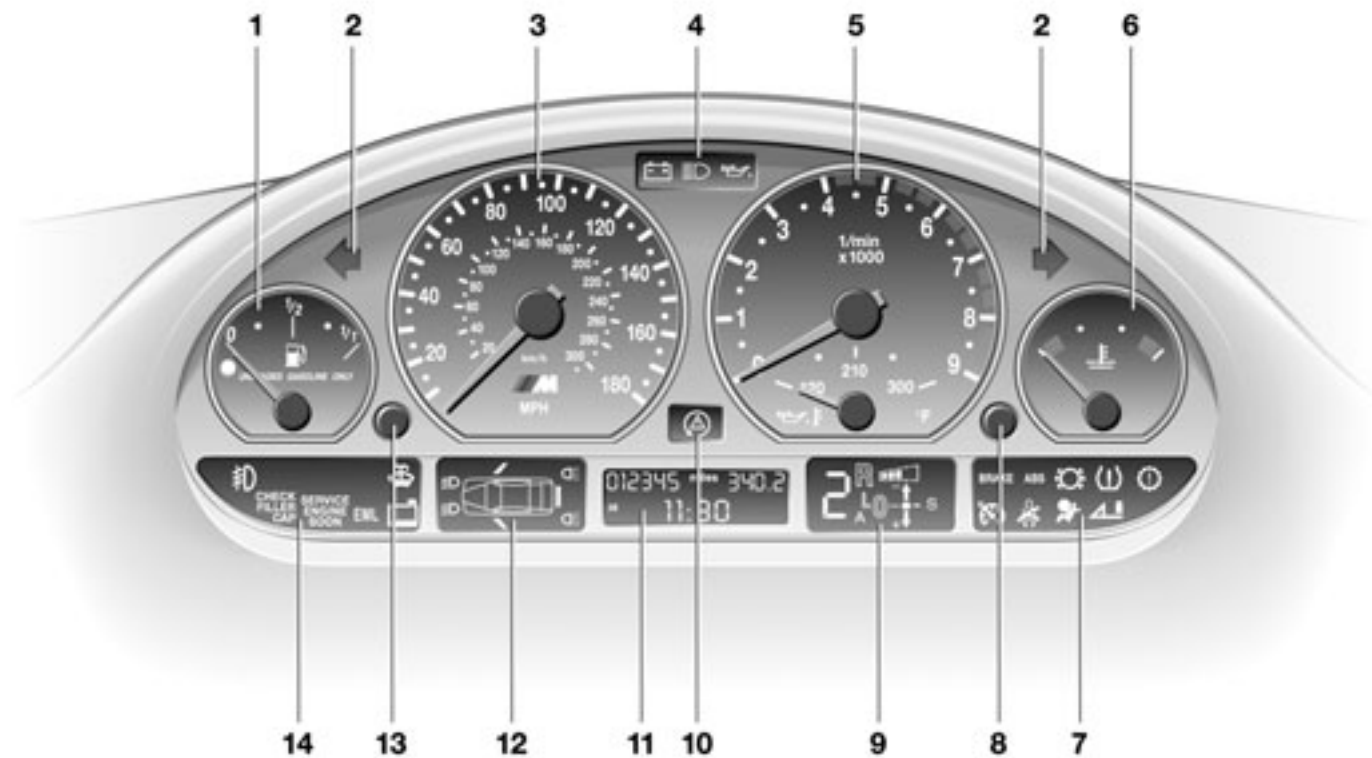

Instrument cluster

- 1 Fuel gauge 81
- 2 Turn signal indicator 20
- 3 Speedometer
- 4 Indicator and warning lamps 18 to 21
- 5 Tachometer and engine oil temperature gauge 80
- 6 Engine coolant temperature gauge 81
- 7 Indicator and warning lamps 18 to 21
- 8 Clock reset
 - ▷ Clock 83
 - ▷ Unit of measure of outside temperature display 84
- 9 Display for sequential M gearbox SMG II 72
- 10 Indicator lamp for Dynamic Stability Control (DSC) 87
- 11 Display for
 - ▷ Trip odometer 80
 - ▷ Clock 83
 - ▷ Service interval 82
 - ▷ Computer 84
- 12 Check Control 82
- 13 Trip odometer, reset to zero 80
- 14 Indicator and warning lamps 18 to 21

18 Indicator and warning lamps

Technology that monitors itself

Indicator and warning lamps that are identified by ● are tested for proper functioning whenever the ignition key is turned. They each light up once for different periods of time.

If a fault should occur in one of these systems, the corresponding lamp does not go out after the engine is started or it lights up while the vehicle is moving. You will see how to react to this below.

Red: stop immediately

 Battery charge current ●
The battery is no longer being charged. There is a malfunction of the alternator drive belt or in the charging circuit of the alternator. please contact the nearest BMW center.

 If the drive belt is defective, stop and switch off the engine immediately to prevent overheating and serious engine damage. If the drive belt is defective, increased steering effort is also required. ◀



● Engine oil pressure
An alarm sounds at the same time. Stop vehicle immediately and switch off engine. Check the engine oil level and top up as required. If the oil level is correct, please contact the nearest BMW center.



Do not continue driving, as the engine could sustain serious damage from inadequate lubrication. ◀



● Flat Tire Monitor
In addition, an acoustic signal is sounded: a tire failure has occurred. To come to an immediate stop, reduce speed, while avoiding any sudden, jerky braking or steering maneuvers.
For additional information: refer to page 88



● Brake warning lamp
If the lamp comes on when the parking brake is not engaged: check the brake fluid level. Before driving further, be sure to comply with the instructions on pages 112 and 127.



● Brake warning lamp for Canadian models.

Red: an important reminder



● Brake warning lamp
Comes on when the parking brake is engaged – an additional acoustic signal sounds when starting off. For additional information: refer to page 69



● Brake warning lamp for Canadian models.



● Lock backrest/Please fasten safety belts
comes on together with an acoustic signal until the safety belts are fastened. Flashes when the backrest is not locked.

For additional information on locking the backrest, refer to page 51
For additional information on safety belts: refer to page 52



● Airbags
Please have the system inspected at your BMW center.
For additional information: refer to page 57

Indicator and warning lamps

Red and yellow: continue driving cautiously



The red brake warning lamp lights up together with the yellow indicator lamps for ABS ● and DSC:



The entire ABS, CBC and DSC control system has failed. Continue to drive; drive cautiously and defensively and avoid full brake applications. Please have the system checked by your BMW center as soon as possible.

For additional information: refer to pages [87](#), [111](#)



Indicator and warning lamps CBC, ABS and DSC for Canadian models.



Orange: consult the nearest BMW center



Sequential M gearbox SMG II
If the indicator lamp fails to go out after the engine has been started, or if it comes on during normal driving: this indicates a malfunction in the system. Please consult the nearest BMW center.

Indicator lamp flashes: a system overload has occurred.
For additional information: refer to page [75](#)

Yellow: check as soon as possible



Engine oil level
Comes on while driving and is accompanied by an alarm: the engine oil level has fallen to the absolute minimum; refill as soon as possible. Do not drive more than 30 miles/50 km before refilling.

For additional information: refer to page [124](#)



Engine oil level
Comes on after the engine has been shut off and is accompanied by an alarm: add engine oil at your earliest opportunity such as when you stop to refuel

For additional information: refer to page [124](#)



Brake pads ●
Have the brake pads checked.
For additional information: refer to page [112](#)



Flat Tire Monitor ●
The Flat Tire Monitor has been deactivated, either at the button or in response to a system malfunction. In the event of a malfunction, have the system checked by your BMW center.
For additional information: refer to pages [25](#), [88](#)



Dynamic Stability Control (DSC) ●
The indicator lamp flashes and an acoustic signal sounds: the system is active and governs drive and braking force.

If the indicator lamp fails to go out after the engine is started, or if it comes on during normal driving and stays on: DSC has been deactivated, either at the

20 Indicator and warning lamps

button or in response to a system malfunction. In the event of a malfunction, have the system checked by your nearest BMW center.

For additional information: refer to page [87](#)



Dynamic Brake Control (DBC) ●
Malfunction in DBC system. Conventional braking efficiency is available and unrestricted.

Have the system checked and repaired at your BMW center as soon as possible.

For additional information: refer to page [88](#)



Dynamic Brake Control (DBC) warning lamp for Canadian models.



Add washer fluid

The washer fluid is too low. Top off the fluid at the earliest opportunity.

For additional information: refer to page [124](#)



SERVICE ENGINE SOON ●

If the indicator lamp comes on either continuously or intermittently, this indicates a fault in the emissions-related electronic systems.

Although the vehicle remains operational, you should have the systems checked by your BMW center at the earliest possible opportunity.

For additional information: refer to page [130](#)



Service Engine Soon warning lamp for Canadian models.



Engine electronics ●
There is a fault in the electronic engine-management system.

You can continue to drive with reduced engine output or engine speed. Please have the system inspected at your BMW center.



Add coolant
Coolant level too low, top up as soon as possible.

For additional information: refer to page [126](#)



CHECK FILLER CAP ●

This indicator lamp comes on when the fuel filler cap is loose or missing.

Close the filler cap tightly: refer to page [24](#)



Rollover protection system ●
The rollover protection system is deactivated due to a malfunction. Please have the system inspected immediately at your BMW center.

For additional information: refer to page [63](#)

Green: for your information



Turn signal indicator
Flashes when turn signals are on. Rapid flashing: indicates a system malfunction.

For additional information: refer to page [76](#)



Cruise control
Lights up when the cruise control is activated. Ready for operation via the steering wheel with multi-function buttons.

For additional information: refer to page [78](#)



Front fog lamps
Lights up whenever the fog lamps are on.

For additional information: refer to page [94](#)

Indicator and warning lamps

Blue: for your information



High beams

Comes on when the high beams are on or the headlamp flasher

is actuated.

For additional information: refer to pages [76](#), [93](#)

22 Steering wheel with multifunction buttons

These buttons let you operate the following functions quickly and without being distracted from traffic conditions:

- ▷ Selected radio functions
- ▷ The cruise control
- ▷ Several telephone* functions.

 The controls are active only when the corresponding systems and accessories are switched on. ◀



Press briefly:

Accept incoming call, start dialing, terminate call.



Switch between phone and radio, cassette, CD and MD.



Forward:

- ▷ Radio
Press briefly: station scan in FM band
Extended pressure: station search
- ▷ CD/MD
Press briefly: jump to next track
Extended pressure: search function in track

- ▷ Cassette
Press briefly: jump to next track or stop fast forward
Extended pressure: fast forward
- ▷ Phone
Scan personal phone book.



Rewind: same functions as forward.



Volume.



Cruise control: select a stored setting.



Cruise control: store and accelerate + or decelerate and store -.

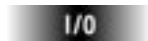

Cruise control: activate/interrupt/deactivate.

Hazard warning triangle*



The hazard warning triangle is stored ready to use in the luggage compartment lid inside the toolbox for the onboard tool kit.

To open the container, loosen the wing nut.

 Always observe all legal regulations requiring a warning triangle to be carried in the vehicle. ◀

First-aid kit*

23



The first-aid kit is located under the front passenger's seat.

To open: pull the handle and fold the cover down.

To fasten: fold the cover up and press it until the tab engages.

 Several of the items contained in the first-aid kit have a limited service life. For this reason, check the expiration dates of each of the items regularly, and replace any with passed dates. You can acquire replacements in any drugstore or pharmacy. Always observe all legal regulations requiring a first-aid kit to be carried in the vehicle. ◀



 When handling fuels, comply with all of the applicable safety precautions posted at the service station. Never carry spare fuel containers in your vehicle. Whether empty or full, these containers can leak, cause an explosion, or lead to fire in the event of a collision. ◀



Fuel filler door

 Always switch off the engine before refueling, as it is not possible to add fuel with the engine running, and attempts may also trigger the SERVICE ENGINE SOON lamp. ◀

Press on the rear edge of the fuel filler door to open and close it.

If an electrical malfunction occurs, you can unlock the fuel filler door manually: Pull the knob with the fuel pump symbol on the right trim panel of the luggage compartment.

Simple and environmentally friendly

 Open the filler cap carefully to prevent fuel from spraying out. Fuel spray may cause injury. ◀

Keep the filler cap in the bracket attached to the fuel filler door – see arrow.

When refueling, insert the filler nozzle completely into the filler pipe. Pulling the nozzle out of the pipe during refueling

- ▷ results in premature pump shutoff
- ▷ and will reduce the effect of the vapor recovery system on the pump.

The fuel tank is full when the filler nozzle shuts off the first time.

Refueling

 Close the fuel filler cap carefully after refueling until a click is heard. While closing, be sure not to squeeze the strap which is fastened to the cap. A loose or missing cap will activate the CHECK FILLER CAP lamp. ◀

Fuel tank capacity

- ▷ Approx. 16.6 gal./63 liters, of which
- ▷ approx. 2.1 gal./8 liters are reserve capacity.

 Do not drive to the last drop of fuel. This can prevent the engine from operating properly and result in damage. ◀

Fuel specifications

The engine uses lead-free gasoline only.

Required fuel:

- ▷ Premium Unleaded Gasoline, min. 91 AKI.
- AKI = Anti Knock Index

 Never use leaded fuel, as it would cause permanent and irreversible damage to the oxygen sensor and the catalytic converter. ◀

Tire inflation pressure



The specified inflation pressures are provided on a sticker attached to the B-pillar and are visible with the driver's door open.

Checking tire pressures

All pressures are specified in the units usually used in your country – psi/kilo-pascal – for tires at ambient temperatures, also refer to the following tire inflation pressure table.

After correcting the tire inflation pressure, reinitialize the Flat Tire Monitor so that it can monitor the tire inflation pressure, refer to page 88.

26 **Tire inflation pressure**





Check the tire pressures on a regular basis – at least twice a month – and before every extended journey. Incorrect tire pressure can otherwise lead to driving instability, tire damage and accidents. ◀

Comply with tire approval specifications

The inflation pressures in the table apply to BMW-approved tire sizes and tire manufacturers. Your BMW center will be glad to supply this information. Higher pressures may be required for tires made by other manufacturers.

Your vehicle is equipped with tires which not only meet US standards, but also European standards. We recommend the exclusive use of BMW-approved tires.

Tire inflation pressure

BMW	Tires	 			
	All pressure specifications in the table are indicated in psi/kilopascal with cold tires – cold = ambient temperature				
	225/45 ZR 18	33/230	-	41/280	-
	255/40 ZR 18	-	35/240	-	48/330
M3 convertible	225/40 ZR 19	33/230	-	41/280	-
	255/35 ZR 19	-	35/240	-	48/330
	225/45 R 17 91 H M+S	33/230	38/260	36/250	46/320



Overview

Controls and features

Operation, maintenance

Owner service procedures

Technical data

Index

Overview

Controls

Maintenance

Repairs

Data

Index



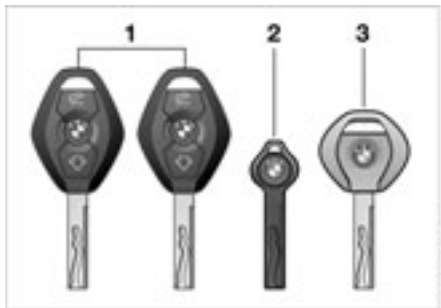

The key set

- 1 Master keys with remote control unit – determine the functions of the Key Memory, refer to page 65.

You can mark the individual keys for subsequent identification by applying the colored decals that you received when accepting delivery of your vehicle

▶ There is an extended-life battery in every master key with remote control that is charged automatically in the ignition lock as you drive.

For this reason, if you have a master key with remote control that is otherwise not used, use that key at least once every year while driving for an extended period to charge the battery. ◀

- 2 Spare master key – for storage in a safe place, such as in your wallet. This key is not intended for constant use
- 3 Door and ignition key – the locks for the luggage compartment lid and the glove compartment cannot be operated with this key. This is useful for valet parking, for example

Central locking system

The concept

The central locking system engages and releases the locks on the

- ▷ doors
- ▷ luggage compartment lid
- ▷ fuel filler door and
- ▷ glove compartment.

The central locking system is ready for operation whenever the driver's door is closed.

The central locking system can be operated

- ▷ from outside via the door lock and using the remote control
- ▷ from inside via the central locking system button.

If it is operated from inside, the fuel filler door will not be locked, refer to page 34.

Operating it from outside simultaneously activates the anti-theft system, which prevents the doors from being unlocked via the door lock buttons or the door release handles. The alarm system is also armed or disarmed.

The central locking system unlocks automatically in the event of an accident. In addition, the hazard warning flashers and interior lamps come on.

Opening and closing – via the remote control

The concept

The remote control gives you an exceptionally convenient method for unlocking and locking your vehicle. Furthermore, it provides two additional functions:

- ▷ Switch on the interior lamps, refer to page 32.
- With this function you can also search for your vehicle – when parked in an underground garage, for instance
- ▷ Open the luggage compartment lid, refer to page 32.

The luggage compartment lid will open slightly, regardless of whether it was locked or unlocked.

The anti-theft system is also deactivated/activated simultaneously with the unlocking or locking of the vehicle, and the alarm system is disarmed/armed, and the interior lamps are switched on/off.



You can have a signal set to confirm that the vehicle's locks have engaged securely. ◀

Master keys with remote control



Since passengers or animals remaining in the vehicle might be able to lock the doors from the inside, always take the vehicle's keys with you so that the vehicle can be opened again from the outside at any time. ◀



If it is no longer possible to lock the vehicle via the remote control, the battery is discharged. Use this key while driving for an extended period in order to recharge the battery. Guard the remote control against unauthorized use by only surrendering the spare key or the door and ignition key, e.g. for valet parking. In the event of a system malfunction, please contact your BMW center. You can also obtain replacement keys there. ◀



- 1 Unlock, disarm the alarm system
- 2 Lock and secure, arm alarm system, activate interior lamps, disarm tilt alarm sensor and interior motion sensor
- 3 Open luggage compartment, Panic mode – trigger alarm

To release



Press button to unlock the driver's door only.



Press the button twice in order to unlock the entire vehicle. ◀

32 Opening and closing – via the remote control

To lock and secure



Press button.

To switch on the interior lamps



After locking the vehicle, press button again.

To deactivate the tilt alarm* and interior motion sensors*



Press button a second time immediately after locking.

For additional information: page 39.

To open the luggage compartment



Press button.

The lid will open slightly, no matter whether it was locked or unlocked.

 Before and after a trip, be sure that the luggage compartment lid has not been opened unintentionally. ◀

Panic mode – trigger alarm



By pressing button for more than two seconds, the alarm can be sounded in the event of danger, if it is armed.

To switch off the alarm:



Press button.

External systems

Local systems or devices in the area may interfere with remote control function.

If this should occur, you can still open and close the vehicle using the master key in both the door and luggage compartment locks.

For US owners only

The transmitter and receiver units comply with part 15 of the FCC Federal Communications Commission regulations. Operation is governed by the following:

FCC ID:

- ▷ LX8EWS
- ▷ LX8FZVS

▷ LX8FZVE.

Compliance statement:

This device complies with part 15 of the FCC Rules. Operation is subject to the following two conditions:

- ▷ This device may not cause harmful interference, and
- ▷ this device must accept any interference received, including interference that may cause undesired operation.



Any unauthorized modifications to these devices could void the user's authority to operate the equipment. ◀

Opening and closing – via the door lock



▷ To fasten: with the door closed, hold the key in the Lock position.

 Whenever closing the windows or sliding/tilt sunroof you should always monitor their path and progress to ensure that no one is injured occur. Releasing the key stops the operation. ◀

Manual operation

In the event of electrical malfunction Turn the key all the way to the left or right to unlock/lock the driver's door.

Turning the key in the door lock once unlocks the driver's door, the fuel filler door and the glove compartment.

Turning the key a second time unlocks the passenger's door and the luggage compartment lid.



You can have a signal set to confirm that the vehicle's locks have engaged securely. ◀

Convenience operation

With the door closed you can also operate the power windows and the convertible top with the door lock.

▷ To open: with the door closed after turning the key for the second time, hold the key in the Unlock position

34 Opening and closing – from the inside



With this button you operate the central locking system whenever the doors are closed. The doors and luggage compartment lid are unlocked or locked only. The anti-theft alarm system is not activated.

 If only the driver's door was unlocked from the outside and you press the button, then, with the driver's door still open, the passenger's door, the luggage compartment lid, the fuel filler door and the glove compartment will unlock, too.

If the driver's door is closed, it will be locked. ◀



If you desire, the central locking system can be activated automatically as soon as you begin to drive. You may also have this adjusted so that it is specific to keys. ◀

To unlock and open the doors

- ▷ Either unlock the doors together with the button for the central locking system and then pull each of the release handles above the armrests or
- ▷ pull the release handle for each door twice: the first pull unlocks the door, and the second one opens it.

To lock

- ▷ Either use the central locking button to lock all doors at once or
- ▷ press the individual door lock buttons down. As an added design feature to prevent the driver from being inadvertently locked out of the vehicle, the driver's door lock button will not engage as long as the door is open.



Since passengers or animals remaining in the vehicle might be able to lock the doors from the inside, always take the vehicle's keys with you so that the vehicle can be opened again from the outside at any time. ◀

Luggage compartment lid



The lock

Only the master keys fit in the lock for the luggage compartment lid, refer to page 30.

To secure separately

Lock the glove compartment using the master key.

The luggage compartment lid is locked and disconnected from the central locking system. If you surrender only the door and ignition key – refer to page 30 – this will prevent unauthorized access via the luggage compartment lid, which is an advantage for valet parking, for instance.

To open from the outside

Press the button in the handle recess – see arrow: the luggage compartment lid opens slightly.

The luggage compartment is lighted when the luggage compartment lid is opened.

Manual operation

In the event of electrical malfunction Turn the master key to the right as far as it will go, the luggage compartment lid will open slightly.

The luggage compartment lid is locked again as soon as you close the lid.

To open from the inside

If the luggage compartment lid has not been locked separately, you can open it with this button in the footwell on the driver's side when the vehicle is stationary.

36 Luggage compartment lid

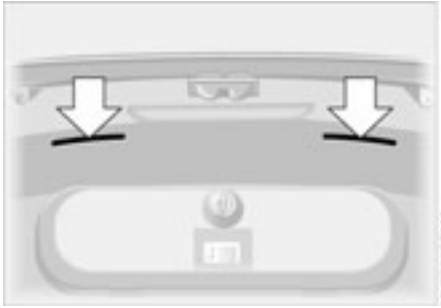



Nevertheless, should it be absolutely necessary to operate the vehicle with the luggage compartment lid open, with closed convertible top:

1. Close all windows
2. Greatly increase the quantity of air from the automatic climate control system, refer to page 98.

To close

The handle recesses – see arrows – in the interior trim panel of the luggage compartment lid make it easier to pull the lid down.

 To avoid injuries, be sure that the travel path of the luggage compartment lid is clear when it is closed, following the same precautions as with all closing procedures. ◀

 Operate the vehicle only when the luggage compartment lid is completely closed. Otherwise, exhaust fumes could penetrate the interior of the vehicle. ◀



Emergency release

This lever releases the luggage compartment lid from the luggage compartment's interior.



To fold up and secure the floor panel

1. Pull up at the handle and fold the panel up
2. Press the button – see arrow – to release the hanger from the handle

3. Hook the handle into the rubber seal of the drip rail – see arrow.

 Carefully replace the hanger in its holder when lowering the floor panel back down. ◀

The fittings at the corners of the luggage compartment provide you with a convenient means of attaching luggage nets* and flexible straps for securing luggage.

Refer also to Cargo loading on page [106](#).

Enlarging luggage compartment

With the convertible top closed, you can enlarge the luggage compartment. To do this, flip the handle outward and press it down and toward the front of the vehicle – see arrow. The convertible top compartment panel is now raised and secured.

To fold down the convertible top compartment panel

To open the convertible top, the convertible top compartment panel must be lowered. To do this, fold out the handle and pull opposite the direction of travel.



When opening the convertible top, refer to page 41, make sure that the luggage compartment is set up for this, otherwise you may damage something. ◀

The concept

The vehicle alarm system responds:

- ▷ When a door, the hood or the luggage compartment lid are opened
- ▷ To movement inside the vehicle – interior motion sensor
- ▷ Altering the vehicle tilt, e.g. as would occur while attempting to steal the wheels or tow the vehicle – tilt alarm sensor system
- ▷ To interruption of battery voltage.

The system responds to unauthorized vehicle entry and attempted theft by simultaneously activating the following:

- ▷ Sounding an acoustic alarm for 30 seconds
- ▷ Activating the hazard warning flashers for approx. five minutes
- ▷ Flashing the high beams on and off in rhythm with the hazard warning flashers.

To arm and disarm the alarm system

When the vehicle is locked or unlocked by using a key or with the remote control, the alarm system is also simultaneously armed or disarmed.



You can have a signal set as acknowledgment for both arming and disarming the alarm. ◀



You can also open the luggage compartment lid when the system is armed by pressing the button of the remote control, refer to page 32. When it is closed, the lid is once again secured.

Alarm system*



Indicator lamp displays

- ▷ The indicator lamp below the interior rearview mirror flashes continuously: the system is armed
- ▷ The indicator lamp flashes when it is armed: the door(s), the hood or luggage compartment lid are not completely closed. Even if you do not close the alerted area, the remaining areas are deadlocked, and the indicator lamp flashes continuously after ten seconds. However, the interior motion sensor is not activated
- ▷ If the indicator lamp goes out when the system is disarmed: no manipulation or attempted intrusions have been detected in the period since the system was armed
- ▷ If the indicator lamp flashes for ten seconds when the system is dis-

armed: an attempted entry has been detected in the period since the system was armed.

Following triggering of an alarm, the indicator lamp will flash continuously.

Avoiding unintentional alarms

The tilt alarm sensor and interior motion sensor may be deactivated at the same time. You can do this to prevent a false alarm from being triggered in garages with elevator ramps, for instance, or when the vehicle is transported by train:



Lock the vehicle twice to arm the system. Press button on the remote control twice in succession or lock the vehicle twice with the key.

The indicator lamp lights up briefly and then flashes continuously. The tilt alarm sensor and the interior motion sensor are deactivated as long as the system is armed.

Interior motion sensor*

Deactivate the interior motion sensor – see Avoiding unintentional alarms – if persons or animals are left in the vehicle.

▶ The tilt and interior motion sensors are inadvertently switched off when convenience closing of the windows is interrupted within the first 10 seconds and then started again. If this happens, they must be disarmed and reactivated. ◀



You can close the windows in the same manner by pulling the switch. The window on the passenger side and the rear windows to not close automatically.

 The window on the passenger side closes automatically in ignition key position 2 only. ◀

For convenience closing via the door lock, refer to page 33.



To open and close windows

 When leaving the vehicle, always remove the ignition key from the lock and remember to close the doors to prevent children from operating the power windows and injuring themselves, etc. ◀

With the ignition key in position 1 or higher

- ▷ Press the switch until you feel resistance: the window continues to move as long as you continue to press the switch
- ▷ Press the switch briefly past the pressure point: the window moves automatically. Touching the switch again stops the opening cycle.

Operating all windows at once

With the ignition key in position 1 or higher

- ▷ Press the switch until you feel resistance: all of the windows will continue to lower as long as you continue to press the switch
- ▷ Press the switch briefly past the pressure point: all windows will move automatically. Pressing the switch again stops the opening cycle.

You can close the windows in the same manner by pulling the switch. The windows cannot be closed automatically using this switch.

For convenience closing via the door lock, refer to page 33.

Electric power windows

After the ignition has been switched off

After the ignition has been switched off: You can still use the electric power windows for up to 15 minutes, as long as no one opens any of the doors.

Convertible top

The completely automatically operated convertible top combines assured protection against the elements together with simple and easy handling.

So that you will get the most out of enjoying your convertible, here are a few tips:

- ▷ It is advisable to close the convertible top when the vehicle is being parked. The closed convertible top not only protects the passenger compartment from unforeseeable damage from the weather, it also provides a certain degree of theft protection. In addition, keep valuables only in the locked luggage compartment, even with the convertible top closed
- ▷ Never mount a roof-mounted luggage rack on the convertible top
- ▷ At temperatures below 14 °F / -10 °C do not operate the convertible top to prevent damage.

 Never store the convertible top while it is wet to avoid permanent damage from moisture. ◀

42 Convertible top

 Driving with the opening or closing operation not completely ended can lead to damage and/or injuries.

Traffic laws applicable in your area take precedence when you operate the convertible top, otherwise you may be breaking the law.

Do not lay objects on the convertible top, since they would fall off when the convertible top is operated and cause damage or injuries.

Do not reach into the convertible top mechanism during opening and closing. Keep children away from the moving parts of the convertible top during operation. ◀

 If possible, only operate the convertible top with the vehicle stopped, as otherwise the process may be interrupted.

If you set the convertible top in motion with the vehicle stationary and then have to start suddenly – for instance, at a traffic light – you can still complete the operation by driving as slowly as possible and again pressing and maintaining pressure on the button.

Before closing the convertible top, remove any objects from the windshield frame that could keep the convertible top from closing properly. ◀

 To close the electric power windows while driving, always be sure to first close either the rear windows, or all 4 windows at the same time, otherwise, at high speed, the windows may not close tightly. ◀

 At higher speeds, the ensuing vacuum in the passenger compartment can cause the convertible top to begin fluttering. Increase the air supply via the ventilation controls so that a vacuum does not occur in the vehicle. ◀



- 1 To close
- 2 To open

Locks and security systems

From ignition key position 1 or higher, with the vehicle stationary

If at all possible, only operate the convertible top if the engine is running. This saves unnecessary battery wear.

1. Read and comply with the preceding safety precautions
2. Before opening the convertible top, make sure that the convertible top compartment panel in the luggage compartment is lowered, refer to page 37
3. Make sure that the luggage compartment lid is closed

Convertible top

4. Press and hold the corresponding button for convertible top operation. The red indicator lamp will light up while the convertible top is in motion. It goes out as soon as the opening or closing operation has been completed.

If the red indicator lamp flashes after the button is released, then the opening or closing operation is not yet completed. The sequence can be continued in the desired direction by pressing this button.

If the yellow indicator lamp lights up continuously with the button pressed, then the convertible top compartment panel is raised and the convertible top cannot be moved, refer to step 2.

 The automatic sequence will be interrupted immediately if you release the button that operates the top. The sequence can be continued in the desired direction by pressing this button. ◀

 During convertible top operation the rear window moves toward the passenger compartment. To prevent injuries, make sure that the closing path of the convertible top is unobstructed. ◀

When operating the convertible top, the windows will lower slightly when you press the button, and after the opening or closing operation has finished, they will go back up, if you keep holding the button down for more than 2 seconds after the indicator lamp has gone out.

The luggage compartment lid cannot be opened while the convertible top is in motion.

 Do not close the side power windows using the buttons if the convertible top operation has been interrupted. ◀

 If the convertible top has been stored in the convertible top compartment for longer periods, e.g. during the winter months while the hardtop is being used, it may be necessary to manually support the first automatic closing operation: if the convertible top should halt right before the closing phase is completed, press against the front part of the convertible top frame from the outside to help the closing process along. Keep pressing the button while doing so until the top starts up again on its own. ◀

 Operate the convertible top manually in emergency situations only to avoid causing damage due to incorrect operation. ◀

 If the opening or closing operation is interrupted, the convertible top remains in the respective position for 15 minutes, and the sequence can be continued in the desired direction with the button. After that, the convertible top can be moved again and, if it is an emergency situation, you may have to help the top along manually. This can also be done in ignition key position 0. In certain cases, the luggage compartment lid cannot be opened if the opening or closing operation has been interrupted. ◀

Convenience operation from the driver's door lock

Refer to page 33.

44 Convertible top





1. Remove the center piece between the rear seats. Take the trim off of the guide rod and flip it forward. Press down hard on the emergency lock 1 – see arrow. After a brief pause, the mechanisms for the convertible top compartment lid will be unlocked

 If the mechanisms for the convertible top compartment lid do not unlock, then insert the Allen wrench 2 into the recess 3 and turn clockwise until the mechanisms unlock. ◀

Closing manually in the event of an electrical malfunction

- 1 Emergency operation
- 2 Allen wrench
- 3 Recess

 Only actuate the convertible top manually to close it, however never to open it, as the convertible top compartment lid cannot be locked and would open during driving. ◀

 Manual closing is best carried out with two persons from outside with the driver's door open and the driver's seat folded forward. No one is to be in the rear seat while you are doing this. ◀



3. Grasp the convertible top by the lateral guide section – see arrow 1 – and the front convertible top frame – see arrow 2. Lift out the top and swing forward until you encounter a perceptible resistance at a stop. Position the rear convertible top frame vertically and close the convertible top compartment lid. Flip the rear convertible top frame downward

 To avoid damaging the side trim, always fold the convertible top forward before folding the rear frame brace up into its vertical position. ◀



 The closing operation must be completed, as otherwise damage and/or injuries may result. ◀

 Please consult your BMW center to have the defect corrected. ◀

4. Lift out the cover panel that is in the center of the front convertible top frame
5. Put the Allen wrench 2 – refer to page 44 – into the hex slot – see arrow
6. Pull down on the front convertible top frame as far as possible. Close the convertible top further by turning the wrench in a clockwise direction; continue turning until the front convertible top frame is locked to the windshield frame. The rear convertible top frame will automatically be pressed down onto the convertible top compartment lid and, because of the tension, will close completely.

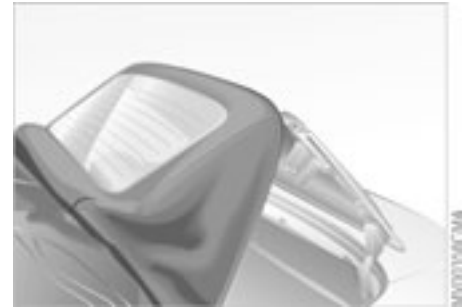

Position for cleaning

To be able to access the convertible top compartment, lean the rear frame of the convertible top against the cover of the convertible top compartment.

 First, use the button for activating the convertible top to unlock the locks of the convertible top compartment. Refer to page 42. ◀

 For additional information on vehicle care, refer to the Caring for your vehicle brochure. ◀

46 Wind deflector*

With the convertible top open, the wind deflector keeps air movement in the passenger compartment to a minimum, thus providing you with a pleasant drive, even at higher speeds. The wind deflector comes in a protective sleeve, and because of its slim dimensions, can be easily stored in the luggage compartment.

Installation

1. Remove wind deflector from the protective sleeve
2. Flip out both sides and lock into place. It is essential for the two components marked in the illustration – see arrows – to mesh at this point
3. Hold the wind deflector so that the smaller half points toward the front and guide the mounting pin for the side piece into the proper opening
4. Pull back on the mounting pin for the other side piece by using a slide, so that the mounting pin can be guided into the opening provided
5. Unlock the convertible top compartment lid via the convertible top control button, refer to page 42, and open the convertible top compartment lid
6. Flip the back half of the wind deflector backward, so that the mounts are lying on the vehicle

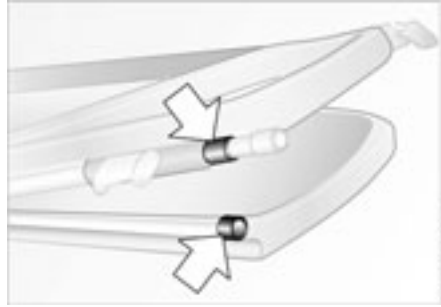

Wind deflector*

7. Close the convertible top compartment lid via the convertible top control button. The wind deflector is now attached so that it is theft-proof.



Operate the convertible top compartment lid from above only in order to avoid any pinching. With the wind deflector in place: never push the front seats all the way back to avoid damaging the wind deflector. ◀

Removal

Follow the same procedure as when installing, just reverse the steps.

For relaxed and fatigue-free driving you should select a sitting position that reflects your personal requirements. In combination with the safety belts and airbags, the correct seating position plays an important role in enhancing occupant safety in the event of an accident. To ensure that the vehicle's safety systems provide you with optimal protection, we request that you direct your careful attention to the following section.

For supplementary information on transporting children, refer to page 59.

Sitting safely with airbags

 Always maintain an adequate distance between yourself and the airbags. Always hold the steering wheel by the rim to keep any chance of injury to hands or arms to an absolute minimum should the airbag be deployed. Never allow any objects, individuals or animals to obstruct the areas between passengers and airbags. Never use the front airbag's cover as a storage tray or support for objects of any kind. Never allow front passengers to rest their feet on the airbag cover. ◀

For airbag locations and additional information on airbags, refer to page 57.

Sitting safely with safety belts

 Never allow more than one person to wear a single safety belt. Never allow infants or small children to ride in a passenger's lap. Avoid twisting the belt while routing it firmly across the pelvis and shoulder, wear it as snugly against your body as possible. Do not allow the belt to rest against hard or fragile objects in your pockets. Do not route the belt across your neck, or run it across sharp edges. Be sure that the belt does not become caught or jammed. Avoid wearing bulky clothing and pull on the lap belt periodically to retension it over your shoulders. In the event of a frontal impact, a loose lap belt could slide over the hips, leading to abdominal injury. In addition, the safety belt's restraint effectiveness is reduced if the belt is worn loosely. Expectant mothers should always wear their safety belts, taking care to position the lap belt against the lower hips, where it will not exert pressure against the abdominal area. ◀

For information on using the safety belts, refer to page 52.

Seats

When adjusting your seat, always observe the following precautions

 Never try to adjust your seat while operating the vehicle. The seat could respond with an unexpected movement, and the ensuing loss of vehicle control could lead to an accident. Never ride with the backrest reclined to an extreme horizontal angle – important for front passengers to remember. Keep the backrest relatively upright to minimize the risk of sliding under the safety belt and sustaining injury in an accident.

With the wind deflector in place: never push the front seats all the way back to avoid damaging the wind deflector. ◀

Adjusting the seats

- ▷ Power seat adjustment, refer to page [49](#)
- ▷ Head restraint, refer to page [50](#)
- ▷ Entering the rear, refer to page [51](#).

Power seat adjustment



Seat adjustment

- 1 Tilt angle
- 2 Forward/backward adjustment
- 3 Height
- 4 Backrest angle

You can manually adjust the thigh support.

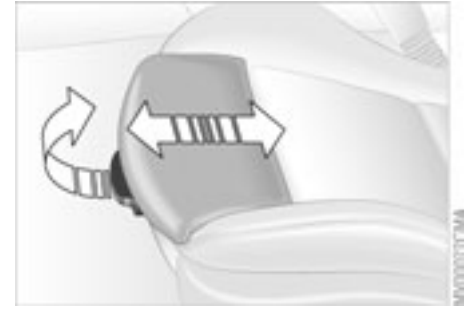

Thigh support

Pull the lever and adjust the position of the cushion for thigh support as desired.



Adjusting the lumbar support*

You can adjust the backrest's contour for additional support in the curvature of your spine's lumbar region.

The upper hips and spinal column receive supplementary support to help you maintain a relaxed, upright position.

- ▷ Press the front/rear of switch: increase/decrease curvature
- ▷ Press the upper/lower end of the switch: increase the upper/lower curvature.



Front head restraints

1 Height

 Head restraints reduce the risk of spinal injury in the event of an accident.

Adjust the head restraint.

When moving the head restraints up or down, do not grab on between the head restraint and the upper edge of the backrest to avoid the possibility of injury. ◀



Tilt angle: position the head restraints manually in the preferred position.



Rear head restraints

 The rear head restraints may only be lowered if there are no passengers in the rear seats. If you do so, you are in violation of the law. Raise the rear head restraints before taking on any passengers in the back. ◀

To completely lower the rear head restraints:

1. Press the button – see arrow – and hold it down
2. Push the head restraint down from above.

Raising the rear head restraints

Raise the head restraints until you hear them click into place.

 Do not remove the rear head restraints as this would damage them. ◀

For further information, please consult your BMW center.

 Do not use the rear head restraints as storage shelves. Always keep the travel path for the roll-over protection system free and clear. Under no circumstances should you put any kind of cover such as an antimacassar on the head restraints, refer also to the labeling on the head restraints. ◀

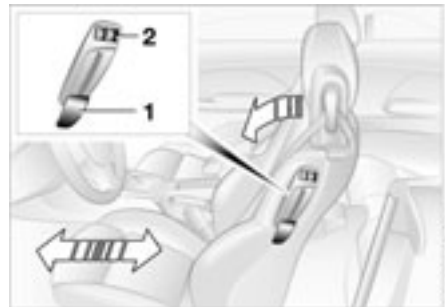

The Seat-integrated safety belt system (SGS) allows for easy access to the rear.

1. Lift the lever 1 up and tilt the backrest forward
2. Press and hold button 2 in driving direction until the seat moves to the desired position
3. After entering the rear, fold back and lock the backrest
4. Press button 2 opposite the direction of travel and hold. The seat moves back into its previous position. If the button 2 is released beforehand, the seat stops in the respective position.

 The seat can be locked into position when it is tilted forward. This is particularly convenient when entering the vehicle on an incline, for example.

Press against the backrest until you hear it snap into place. Lever 1 does not have to be released to fold the seat back. ◀

 Lock both backrests while driving, otherwise there is a danger of an unexpected movement causing an accident. ◀

The indicator lamp in the instrument cluster flashes, when the backrest is not locked, refer to page 18.

Safety belts



Always wear your safety belt

Always fasten your safety belt before starting off. As supplemental restraint devices, the airbags are designed to enhance the effectiveness of the safety belts, and not to replace them.

 Before putting your safety belts on in the rear, take them out of the holder. ◀

 Leave the rear safety belts in the holders if they are not needed, in order to avoid unwanted movement from the safety belts at high speeds. ◀

To close

Make sure you hear the lock engage in the belt buckle.

To release

1. Press the red button in the belt buckle
2. Hold the belt
3. Guide the belt back into its reel.

Adjusting safety belt height

The front safety belt automatically adjusts your body size via the setting of the head restraint height, refer to page 50.

 If the safety belt system has been subjected to the stresses involved in an accident or otherwise damaged: have the entire safety belt mechanism replaced by your BMW center, including the safety belt tensioner. In addition, have your BMW center inspect the safety belt anchors. If a child-restraint system was in the vehicle during an accident, consult the manufacturer's instructions regarding replacement. ◀

Seat and mirror memory



You can store and recall three different driver's seat and outside mirror positions.

 The setting for the lumbar support is not stored in memory. ◀

To store

1. Ignition key in position 1 or 2
2. Adjust your seat and outside mirrors to the desired position
3. Press the MEMORY button: the indicator lamp in the button lights up
4. Press memory button 1, 2 or 3, as desired. The indicator lamp goes out.

To select a stored setting

 Do not select a memory position while the vehicle is moving. If you do so, there is a risk of accident from unexpected seat movement. ◀

Driver's door open after unlocking or ignition key in position 1:

- ▷ Briefly press memory button 1, 2 or 3, as desired.

Movement stops immediately when one of the seat-adjustment or memory buttons is operated during the adjustment process.

With the driver's door closed and the ignition key either removed or in position 0 or 2:

- ▷ Press and hold the desired memory button – 1, 2 or 3 – until the adjustment process is completed.

 If you press the MEMORY button accidentally: press the button again; the indicator lamp goes out. ◀

 Your BMW center can adjust your vehicle's systems in such a manner that your personalized settings are automatically set for the seat and exterior mirror positions when you unlock the vehicle with your personal remote control. ◀

 Before activating the programmed adjustment feature, ensure that the footwell behind the driver's seat is empty and unobstructed. If you fail to do so, any persons, animals or objects behind the seat could be injured or damaged by a rearward movement of the seat. ◀

54 Seat and mirror memory



You can deactivate this automatic feature by setting the mirror selection switch to the passenger side position.

Passenger-side exterior mirror tilt function

Automatic curb monitor*

1. Move mirror selector switch 1 to the driver's mirror position
2. When shifting into Reverse, or placing the selector lever in position R, the passenger-side mirror tilts downward. This brings the lower area adjacent to the vehicle – curbs, etc. – into the driver's field of vision while parking.



How far the passenger mirror tilts can be set individually for each ignition key. ◀

Seat heating*



The seat cushion and backrest can be heated with the ignition key in position 2.

You can call up different heating modes by repeatedly pressing the buttons.

You can also switch the higher heating modes off directly:

Press the button and hold it slightly longer.

Steering wheel

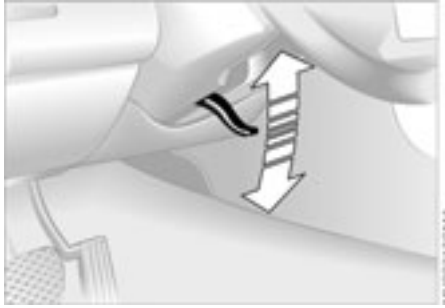

To adjust

⚠ Never attempt to adjust the steering wheel while driving the vehicle – it could respond with unexpected movement, posing a potential accident hazard. ◀

1. Push the locking lever downward
2. Adjusting steering column reach and rake for your selected seating position
3. Pull the lever back up.

Mirrors



than they appear. This means that estimations of the distance to following traffic should not be regarded as precise. ◀

Electric defrosting

Both mirrors are heated automatically in ignition key position 2.

To adjust exterior mirrors

- 1 Switch for 4-way adjustment
- 2 Selection switch for changing between mirrors

To adjust manually

The mirrors can also be adjusted manually:

Press the edges of the lens.

To store the mirror setting, refer to Seat and mirror memory on page 53.

⚠ The passenger-side mirror features a convex lens. When estimating the distance between yourself and other traffic, bear in mind that the objects reflected in the mirror are closer



Interior rearview mirror with automatic dimming feature

This mirror automatically dims through an infinitely variable range and switches automatically to its clear, undimmed mode whenever you engage reverse gear.

There are two photocells for automatic dimming. One photocell – see arrow – is positioned in the mirror's frame, while the other is slightly offset on the opposite side of the mirror.

For the mirror to function perfectly, keep the photocells clean and the area between the inside rearview mirror and the windshield free of any obstruction like stickers, etc.

Airbags

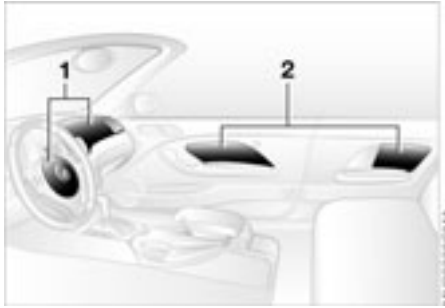



- 1 Front airbags on the driver and passenger sides
- 2 Side airbags on the driver and passenger sides – front and rear*

Protective effect

The front airbags protect the driver and passenger in the event of a head-on collision where the protection provided by the safety belt alone would not be adequate. The side airbags help provide protection in the event of a collision from the side. Each of the side airbags is designed to help support the seat occupant's upper body.

For information on the correct sitting position, refer to page 48.

 The side airbags in the rear passenger area* of your vehicle may already have been deactivated either at the time of manufacture or by a BMW center. You may have them activated if you desire to do so. Please contact your BMW center for additional information. ◀

 The airbags will not be triggered in the event of a minor accident, certain vehicle rollover situations or collisions from the rear. ◀

 Do not apply adhesive materials to the cover panels of the airbags, cover them or modify them in any other way. Do not attempt to remove the airbag restraint system from the vehicle. In the event of a malfunction, deactivation or triggered activation – as a response to an accident – of the airbag restraint system, consult your BMW center for inspection, repair or disassembly. Modifications may not be made on either the wiring or the individual components in the airbag system. This includes the upholstered covers on the steering wheel, the instrument panel, the side trim panels of the doors and front roof pillars and on the sides of the front headliner. Do not attempt to remove or

dismantle the steering wheel. Unprofessional attempts to service the system could lead to failure in an emergency or undesired airbag activation, either of which could result in personal injury. Do not touch the individual components directly after the system has been triggered, as otherwise there is a danger of burns. ◀

 At all times, occupants should sit upright and be properly restrained – infants and small children in appropriate child-restraint systems; larger children and adults using the safety belts. Never let an occupant's head rest near or on a side airbag because the inflating airbag could cause a serious or fatal injury. Please note that the word Airbag imprinted on the door trim panel indicates the airbag's location. Accident research shows that the safest place for children in an automobile is in the rear seat. However, a child sitting in the rear seat and not properly restrained may place his or her head on or near the side airbag, if so equipped. For example, a child – even though belted – may fall asleep with his or her head against the side airbag. It may be difficult for a driver to ensure that children in the rear seat will remain prop-

erly positioned at all times and not place their heads on or near the side airbag. Therefore, we recommend that the rear seat side airbags, if provided, be deactivated if you plan to transport children in the rear seat.

The rear seat side airbags may already have been deactivated, either at the time of manufacture or by a BMW center. Labels in the door opening should indicate the status of your rear-seat side airbags. If you are uncertain of their status, or wish to have the airbags activated or deactivated, please contact your BMW center. ◀

Even when all these guidelines are observed, there is still a small residual risk of injuries to the face, hands and arms occurring from airbag deployment in isolated instances.

The ignition and inflation noise may provoke a mild temporary hearing loss in extremely sensitive individuals.

Airbag warning information is also provided on the sun visors.



This is the right way a child should sit in a child-restraint when rear side airbags, see arrow, are provided.



This is the right way a larger child should sit wearing the seat belt when rear side airbags, see arrow, are provided.

Indicator lamp



The indicator lamp indicates the operational status of the airbag system when the ignition key is in position 1 or higher.

System operational:

- ▷ The indicator lamp comes on briefly when the ignition key is turned to position 1 or higher.

System malfunction:

- ▷ Indicator lamp does not come on or
- ▷ indicator lamp lights up continuously.

Airbags

If there is a system malfunction, there is a risk that the airbags will not be triggered within their normal response range, even if the level of impact would normally have triggered them.

Have your BMW center inspect the system immediately.

Transporting children safely



Leave the rear safety belts in the holders if they are not needed to avoid unwanted movement from the safety belts at high speeds. ◀

Commercially available child seats complying with the legal standard are designed to be secured with a seat belt or with the seat belt portion of a combination lap/shoulder belt. Improperly or inadequately installed restraint systems can increase the risk of injury to children. Always read and follow the instructions that come with the system.

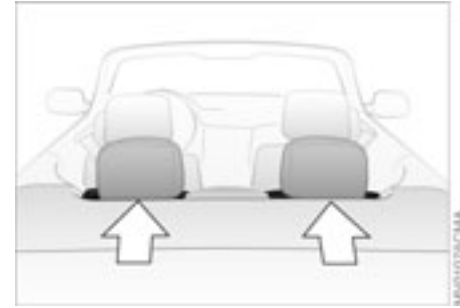

Child-restraint system with tether strap

If you use a child-restraint system with a tether strap, two additional tether anchorage points have been provided – refer to the arrows in the illustration.

60 Transporting children safely

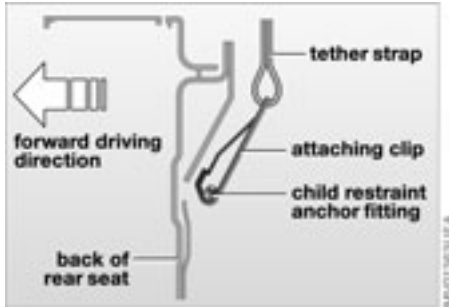

Depending on the location selected for seating in the rear passenger area, attach the tether strap to the corresponding anchorage point to secure the child-restraint system, as shown in the illustration.

1. Open the convertible top compartment lid, refer to page 41
2. Lift the headrest and pass the tether strap between the headrest and the seat back. It is recommended that you return the head restraint back to its lowest possible position
3. Adjust the tether strap according to the child-restraint manufacturer's instructions
4. Close the convertible top compartment panel.

It is recommended to cover the child-restraint attaching clip with a soft material to prevent damage to the stored soft top.

 Should a hard top be installed, the fitting of child harness tether strap/s – if child seat is required – is necessary before installation of the hard top. ◀

 Before installing any child-restraint device or child seat, please read the following:
Never install a rearward-facing child-restraint system in the front passenger seat of this vehicle.
Your vehicle is equipped with an airbag supplemental restraint system for the front passenger. Because the backrest on any rear-facing child-restraint system – of the kind designed for infants under 1 year and 20 lbs/9 kg – would be within the airbag's deployment range, you should never mount such a

device in the front passenger seat, as the impact of the airbag against the child-restraint's backrest could lead to serious or fatal injuries.

If it is necessary for a child – not an infant – to ride in the front seat, certain precautions should be taken. First, move the passenger seat as far away from the instrument panel as possible. This important precaution is intended to maximize the distance between the airbag and the child. Older children

Transporting children safely

should be tightly secured with the safety belt after they have outgrown a booster seat that is appropriate for their age, height, and weight.

Younger children should be secured in an appropriate forward-facing child-restraint system that has first been properly secured with a safety belt. Never install a rearward-facing child-restraint system in the front passenger seat.

We strongly urge you to carefully read and comply with the instructions for installation and use provided by the child-restraint's manufacturer whenever you use such a device.

Do not attempt to modify child-restraint systems. If you do this, the protection provided by these systems could be impaired.

Be sure that all occupants – of all ages – remain properly and securely restrained at all times. ◀

All rear seating positions in your vehicle meet the recommendations of SAE J1819, an industry-recommended practice for securing child-restraint systems in motor vehicles.



Securing child-restraint system

All of the rear belt retractors and the front passenger's safety belt can be locked for mounting and securing child-restraint systems.

A label with the appropriate instructions for this is located in the immediate vicinity of the buckle latch of each safety belt.

To lock the safety belt

Extract the entire length of the belt from the inertia reel mechanism. Allow the reel to retract the belt somewhat and engage the buckle, then tighten the belt against the child-restraint system. The retraction mechanism is now locked.

The belt cannot be extracted further. Always observe the installation instructions provided by the manufacturer of the child-restraint system.

To unlock the safety belt

Release the safety belt, remove the child seat and retract the safety belt to its end position on the belt retractor.

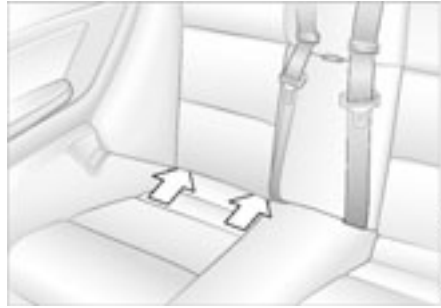

LATCH child-restraint mounting system

LATCH: Lower Anchors and Tether for Children

Canadian models only:

The LATCH anchorage points are identified by buttons.

The left and right rear seats are both equipped with a LATCH child-restraint mounting system.

The anchorage points for the LATCH child-restraint system installation are located behind the upholstery at the positions indicated by the arrows.

Carefully slide the brackets through the gaps in the upholstery at the indicated locations.

 Always follow all manufacturer's instructions and observe all safety precautions when installing the LATCH child-restraint mounting system. Leave the rear safety belts in the holders if they are not needed to avoid unwanted movement from the safety belts at high speeds. ◀

To prevent damage to the upholstery, you can purchase an insertion aid* from your BMW center.

Firmly press the insertion aid into the gap between the seat cushion and backrest, continuing until the two guides snap into place on the LATCH brackets in the seat.

The illustration is an example showing the anchorages for a LATCH child-restraint system on the right rear seat.

Rollover protection system

In the event of an accident or some other critical driving situation – extreme tilting in the longitudinal or transverse axis, loss of contact with the ground – the rollover protection system will be automatically activated. The protective bars located in the rear head restraints extend within fractions of a second.

In addition to the integrated rollover bar in the windshield frame, the rollover protection system affords all the vehicle occupants necessary headroom.



Always keep the travel path for the rollover protection system free and clear. Under no circumstances should you cover the head restraints. In the event of less serious accidents, the safety belt will protect you and, depending on the severity of the accident, so will the safety belt tensioner and the multi-stage airbag restraint system as well. ◀



If, after being automatically triggered, the protective function is not needed, then the rollover protection system can be lowered back into place. No special tool is needed for this.

1. Using a screwdriver from the on-board tool kit, remove the cover panel; to do this, position the screwdriver under the notch – see arrow

2. Pull up on the lever toward the front of the vehicle – see arrow – and keep it in this position

64 Rollover protection system

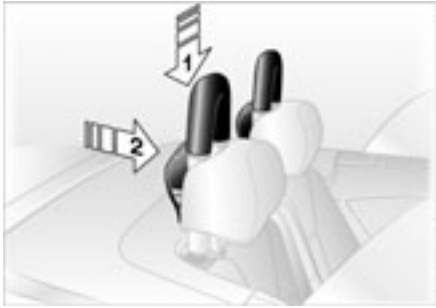

3. Keep pressing down on the protective bar from on top – see arrow 1 – until you hear it click into place
4. Put the cover panel back in place and press down firmly
5. Push the back panel of the head restraint closed – see arrow 2.

Do the same for the second protective bar. If you are not familiar with any of the procedures, consult your BMW center.

Have the rollover protection system checked out by your BMW center after it has been inadvertently triggered.



Do not move the convertible top under any circumstances if the rollover protection system has extended.

Do not use the rear head restraints as storage shelves.

Absolutely no modifications are to be made to any of the rollover protection system's individual components or any of its wiring.

Only your BMW center is to carry out any work on the rollover protection system.

Work done on the system that is carried out improperly could lead to failure in an emergency or accidental airbag activation.

Regarding having the system checked to ensure long-term operation: be scrupulous in adhering to the Service Interval Display for maintenance intervals.

Every two years at the latest, the rollover protection system must be inspected by a BMW center. ◀

Vehicle Memory, Key Memory



How the system functions

You have probably frequently wished that you could configure individual functions of your vehicles to reflect your own personal requirements. In engineering your vehicle, BMW has provided for a number of options for personal adjustment that can be programmed into your vehicle at your BMW center.

The available configuration data fall into two categories, according to whether their primary orientation is the vehicle – Vehicle Memory – or the individual – Key Memory. You can have up to four different basic settings adjusted for four different persons. The only requirement is that each person uses his or her own remote control key.

When your vehicle is unlocked with the remote control, the vehicle recognizes the individual user by means of a data exchange with the key, and makes adjustments accordingly.

In order for you to distinguish between different keys, colored decals are supplied together with the keys.

What the system can do

Your BMW center can provide you with details on the possibilities that the Vehicle and Key Memory systems offer.

Examples for Vehicle Memory:

- ▷ Various signals that can serve as acknowledgment for locking and unlocking the vehicle, refer to page 31
- ▷ Activates/deactivates the Follow me home lamps function, refer to page 92
- ▷ Activates/deactivates daytime driving lamps, refer to page 92
- ▷ Sets the units of measure for displaying time, outside temperature, distance traveled and fuel consumption in the instrument cluster.
- ▷ Indicates via an acoustic tone that PDC has been activated, refer to page 86

- ▷ Switches on rear window defroster automatically, refer to page 99
- ▷ After giving an ice warning, the display returns to the previous setting, refer to page 84.

Examples for Key Memory:

- ▷ Locks the vehicle automatically after you start off, refer to page 34
- ▷ Automatically moves the seat and outside mirror into position for the programmed driver when unlocking the vehicle, refer to page 53
- ▷ Automatic tilting of the passenger-side mirror, refer to page 54
- ▷ After the engine is started, calls up the last selected driving program for each shifting mode, refer to page 74.



You will see this symbol throughout the Owner's Manual. It is to remind you at appropriate places of the settings that are available to you. ◀

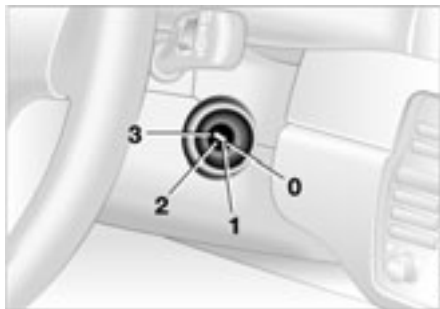

Ignition key positions

- 0 Steering locked
- 1 Steering unlocked
- 2 Ignition switched on
- 3 Starting engine

Steering locked

The key can be inserted or removed in this position only.

After removing the key, turn the steering wheel slightly to the left or right until the lock engages.

If the key is not removed, an acoustic signal is sounded after the driver's door has been opened.

Once the ignition has been switched off, ignition key in position 0 or removed, the radio functions are still available for approx. 20 minutes. Turn the radio back on to use it.

Steering unlocked

You will find that it is often easier to turn the ignition key from position 0 to position 1 when you move the steering wheel slightly to help disengage the lock.

Individual electrical accessories are ready for operation.

Starting engine and driving off

 Do not allow the engine to warm up by leaving it running while the vehicle remains stationary. Instead, drive off immediately at a moderate engine speed. ◀

 Do not allow the engine to run in enclosed spaces. Otherwise, breathing the exhaust fumes can lead to unconsciousness and death. The exhaust gases contain carbon monoxide, an odorless and colorless, but highly toxic gas. Do not leave the vehicle unattended with the engine running. An unattended vehicle with a running engine represents a safety hazard. ◀

If the engine does not start on the first attempt, such as when it is very hot or cold:

▷ Press the accelerator pedal halfway down while engaging the starter.

Cold starts at very low temperatures below about 5 °F / -15 °C and at high altitudes above 3,300 ft / 1,000 m:

▷ On the first start attempt, it may be necessary to engage the starter for a longer period, but no longer than 20 seconds.

 Extended starting attempts, characterized by excessively frequent or long periods with the starter engaged, can damage the catalytic converter. ◀

 When driving, standing at idle, and parking the vehicle, take care to avoid contact between the hot exhaust system and flammable materials – grass, hay, leaves, etc. Such contact could lead to a fire, resulting in serious personal injury and property damage. ◀

Manual transmission

1. Engage the parking brake
2. Gearshift lever in idling position
3. Press the clutch pedal at low temperatures
4. Start the engine. Do not press the accelerator pedal. Do not actuate the starter for too short a time. Do not turn it for more than approx. 20 seconds. Release the ignition key immediately when the engine starts.

Sequential M gearbox SMG II

1. Depress footbrake
2. Move selector lever into position 0

3. Start the engine. Do not actuate the starter for too short a time. Do not turn it for more than approx. 20 seconds. Release the ignition key immediately when the engine starts
4. Engage a driving position
5. Release footbrake and slowly depress accelerator pedal.

 With the engine running, the gear indicator in the SMG display flashes to indicate that a driving position is engaged with the driver's door open or if the hood is not closed properly, refer to page 72.

If none of the pedals is actuated, then the gearbox is automatically taken out of gear after approx. 4 seconds. Then the desired direction of travel must be selected again with the selector lever in position 0. Driving off is not possible with the hood open. ◀

 Before exiting the vehicle with the engine running, move the selector lever into position 0 and apply the parking brake.

Never leave the vehicle unattended with the engine running. An unattended vehicle with a running engine represents a safety hazard. ◀

68 **Starting engine and driving off**

Engine idle speed is controlled by the engine computer system. Increased speeds at start-up are normal and should decrease as the engine warms up. If engine speed does not decrease, service is required.

To prevent the battery from discharging, always deactivate electrical devices that are not in use. Switch the ignition off when the vehicle is not being driven.

Switching off the engine

 You should never remove the ignition key when the vehicle is in motion, as the steering lock could engage. When you leave the vehicle, always remove the ignition key and engage the steering lock. ◀

 Always engage the parking brake when parking on downhill roads. Engaging a gear may not sufficiently secure the vehicle against rolling. ◀

Manual transmission

Turn the ignition key to position 1 or 0.

Sequential M gearbox SMG II

If you turn the ignition key to position 1 or 0 with the selector lever in the forward or reverse position, a gear automatically remains engaged.

If you turn the ignition key to position 1 or 0 with the selector lever in position 0, a warning tone and the flashing gear indicator in the SMG display remind you that the vehicle is not secured against rolling.

The warning stops after approx. ten seconds. If you move the selector lever into a forward or reverse position during this time, a gear is automatically engaged.

Parking brake



The parking brake is designed primarily to prevent the vehicle from rolling when it is parked. It operates against the rear wheels.

To engage

The detent engages automatically, and the indicator lamp in the instrument cluster comes on when the ignition key is in position 2, refer to page 18.

To release

Pull up slightly on the lever, press the button – see arrow – and lower the lever.

 If exceptional circumstances make it necessary to engage the parking brake while the vehicle is in motion, do not pull it with excessive pressure. Keep your thumb pressed against the release button while carefully pulling the lever up. Excessive pressure can lead to over-braking and loss of traction – fishtailing – at the rear axle.

The brake lamps do not come on when the parking brake is engaged.

Always engage the parking brake when parking on downhill roads. Engaging a gear may not sufficiently secure the vehicle against rolling. ◀

 To avoid corrosion and one-sided braking, apply the parking brake lightly from time to time when coasting to a standstill – at a traffic signal, for example – provided that it is safe to do so. ◀

Manual transmission



 When shifting gears in the fifth/sixth gear plane, be sure to press the gearshift lever to the right in order to prevent inadvertent selection of a gear in the third/fourth gear plane. Do not hold the vehicle in place on slopes by slipping or "riding" the clutch. Use the parking brake instead. Riding the clutch causes the clutch assembly to wear out sooner. ◀

Reverse

Select only when the vehicle is stationary. Press the shift lever to the left to overcome the resistance.

As you do this, the backup lamps will light up automatically when the ignition key is in position 2.

Sequential M gearbox SMG II*

The concept

The sequential M gearbox SMG II is an automated manual gearbox with which clutching and shifting is assumed by an electro-hydraulic system.

The SMG II is operated via two shift paddles on the steering wheel and the selector lever in the center console.

It offers the following functions:

- ▷ Sequential and automated shifting mode
- ▷ Ability to choose between different driving programs, Drivelogic
- ▷ Gradient assistance, refer to page [74](#)
- ▷ Upshift display and shift lights, refer to page [75](#)
- ▷ RPM matching on downshifts
- ▷ Driving dependent functions:
 - The respective driving situation, e.g. cornering, mountain driving or braking, is detected by sensors and taken into account for shifting, e.g. to achieve optimum gear selection during deceleration and subsequent acceleration
- ▷ Slip recognition at the rear axle for increasing driving stability, e.g. during downshifting on slippery road surfaces
- ▷ Operating safety through protection against misshifting.

Under normal operating conditions, fuel consumption is lowest when driving in the first driving program of the automated shifting mode.



Selector lever position

R: Reverse position

0: Position 0 (Neutral)

Forward position with one-touch mode:

- ▷ S: sequential mode
- ▷ A: automated mode
- ▷ +: upshifting in sequential mode
- ▷ -: downshifting in sequential mode.

The SMG II is ready for operation from ignition key position two or higher.

For your safety, it is only possible to engage a driving position with the vehicle stopped approx. 2 seconds after engaging position 0 with the footbrake depressed – Shiftlock function.



Display in instrument cluster

The selector lever position, currently engaged gear and selected driving program are displayed in the instrument cluster.

- 1 Engaged gear
- 2 Selected driving program, corresponds to the number of illuminated fields, refer to page 74
- 3 Tapping the selector lever to the right switches over into the displayed shift mode
- 4 "A" indicates an activated automated shift mode

R – Reverse position

Only engage with the vehicle stopped or at low speed, e.g. for rocking free in deep snow.

 An intermittent signal tone indicates that the reverse position has been engaged. ◀

You do not need to reduce the throttle for shifting.

0 – Position 0 (Neutral)

Always engage before starting the engine.

If the driving situation requires, e.g. when downshifting on slippery roads, the SMG II automatically disengages and reengages the clutch, i.e. it is not necessary to manually engage position 0.

S – Sequential mode

In the sequential mode all forward gears are to be shifted by the driver.

Changeover from automated to sequential mode:

- ▷ Tap the selector lever to the right toward S or
- ▷ Change gears with the selector lever or the shift paddles on the steering wheel.



Shifting gears with shift paddles on steering wheel:

- ▷ To upshift, briefly pull the right paddle +
- ▷ To downshift, briefly pull the left paddle -.

 Shift paddles with various widths matched to the shape of your hand are available from your BMW center. ◀

Shifting gears with selector lever:

- ▷ To upshift, pull the selector lever backward +
- ▷ To downshift, push the selector lever forward toward -.

No automatic upshifting is carried out in the sequential mode.

You accelerate from higher gears, e.g. during passing, by manually downshifting.

In the following situations the SMG II helps you think in the sequential mode:

- ▷ Upshifts and downshifts are only executed when the new gear will provide a suitable combination of vehicle and engine speed, i.e., downshifts that would cause the engine to overrev will not be executed
- ▷ During a stop the gearbox is automatically downshifted into the first gear so that, e.g. before a traffic light, it is only necessary to accelerate to continue driving
- ▷ When the speed is reduced, the gearbox is automatically downshifted shortly before a gear-dependent minimum speed is reached without you taking any action.

A – Automated mode

Each time the engine is started, the automated mode is activated as soon as you move the selector lever into the forward driving position.

In the automated mode all forward gears are automatically shifted.

Changeover from sequential to automated mode: tap the selector lever to the right toward A. Watch the display in the instrument cluster, refer to page 72.

For rapid acceleration, e.g. during passing, depress the accelerator pedal completely – kickdown. The gearbox now downshifts in dependence on the selected driving program.

Even in the automated mode, you can help specify the shifting point: if a gear-dependent minimum speed is exceeded, you can upshift by slowly reducing pressure on the accelerator pedal. In the process, the respective driving situation is detected by sensors and taken into account.



In the sequential mode you can choose from six driving programs ranging from balanced, dynamic driving – 1 – to sporty, puristic driving – 6. The sporty, puristic driving program can only be activated with the Dynamic Stability Control (DSC) deactivated, refer to page 87.

 To maintain vehicle stability, always drive with the DSC activated on whenever possible. ◀

Following each change between the sequential and the automated mode, the last driving program selected in the respective mode is active. Exception: instead of the last selected sequential driving program 6, program 5 is activated only after the engine has been started again.

 Your vehicle is set so that when the engine is started, the last selected driving program saved in your key is activated for each shifting mode. ◀

Drivelogic

Drivelogic makes various driving programs available to you.

Press the Drivelogic repeatedly until the desired driving program is shown in the SMG display of the instrument cluster, refer to page 72.

In the automated mode you can select from five driving programs ranging from convenience mode/winter operation to sporty and highly dynamic.

In the first automated driving program, starting off takes place in second gear, which is advisable under winter road conditions with ice and snow.

Gradient assistance

The gradient assistance enables starting off on grades with virtually no roll-back. It can be activated in the sequential and automated mode with the vehicle stopped and can be used for both forward and reverse driving.

 The vehicle may roll slightly before it is held by the gradient assistance after releasing the footbrake. Two seconds after the footbrake is released, the vehicle begins to roll, as it is no longer held with the gradient assistance. ◀

1. Depress footbrake with vehicle stopped
2. Activate the gradient assistance by pulling the left paddle for at least 0.5 seconds. An increase in the engine speed indicates that the gradient assistance is activated

 Briefly pulling the left paddle again deactivates the gradient assistance again. ◀

3. Release the footbrake and start off within two seconds.

The gradient assistance must be reactivated before each use.

Sequential M gearbox SMG II*

Indicator lamp



The transmission indicator lamp in the instrument cluster goes out after the engine is started.

- ▷ If it does not go out, or if it lights up during driving, a fault has occurred. The available functions may be limited under certain circumstances. Drive carefully and with the Dynamic Stability Control (DSC) activated. Have the system checked by the nearest BMW center
- ▷ If the indicator lamp flashes while driving, the system is overloaded. Avoid high loads until the indicator lamp goes out again permanently.



Shift lights

To achieve the best possible vehicle acceleration with a sporty driving style in the sequential mode, shift lights in the instrument cluster indicate the optimum shifting point shortly before the maximum engine speed is reached.

1. When the maximum engine speed is approached, yellow indicator fields, shift lights, in the tachometer light up consecutively to indicate the approaching upshift time
2. Shift at the latest when the last indicator field lights up red.

Tire replacement, snow chains

Following a tire or wheel change and after mounting or removing snow chains, the slip recognition of the SMG II must become familiar with the changed condition.

Reinitialize the system afterwards:

1. Move the selector lever into position 0 on a straight stretch of road at a speed of over 20 mph / 30 km/h
2. Pull both shift paddles for approx. two seconds.

If you do not carry out the initialization, the system automatically learns the changed condition gradually during driving. This can become apparent due to brief opening and closing of the clutch.

76 Turn signal indicator/Headlamp flasher



- 1 High beams – blue indicator lamp
- 2 Headlamp flasher – blue indicator lamp
- 3 Turn signal indicator – green indicator accompanied by periodic clicking sound from the relay

To signal briefly

Press the lever up to but not beyond the resistance point. It then returns to the center position when released.

 If the flashing indicator lamp and the clicking from the relay are both faster than normal, one of the turn signal indicators has failed. ◀



- 0 Wipers retracted
- 1 Intermittent operation or rain sensor
- 2 Normal wiper speed
- 3 Fast wiper speed
- 4 Brief wipe
- 5 Rotary dial for control of the wipe interval or the sensitivity of the rain sensor

Intermittent mode

Not on vehicles with rain sensor.

You can set the wipe interval at four stages with rotary dial 5. In addition, the wipe interval is varied automatically depending on road speed.

Rain sensor

The rain sensor is positioned on the windshield, directly behind the interior rearview mirror.

To activate the rain sensor:

- ▷ With the ignition key in position 1 or higher, move the lever to position 1. The wipers travel once across the windshield, regardless of the weather
- ▷ You can leave the lever permanently in position 1. It is then only necessary to activate the rain sensor when the ignition key is in position 1 or higher. Activate by briefly turning rotary dial 5.

To adjust the sensitivity of the rain sensor: turn rotary dial 5.

To deactivate the rain sensor: put lever in position 0.



Turn the rain sensor off in automatic car washes. Failure to do so could result in damage caused by undesired wiper activation. ◀

Normal wiper speed

When the vehicle is stationary, the wipers switch automatically to intermittent wipe – not on vehicles with rain sensor.

Fast wiper speed

When the vehicle is stationary, the wipers operate at normal speed – not on vehicles with rain sensor.



0 Wipers retracted

1 Clean windshield and headlamps

Clean windshield and headlamps*

 Do not use the washers if there is any danger that the fluid will freeze on the windshield, as your vision could be obscured. Always use a windshield washer antifreeze in cold weather. Refer to page 124.

Do not use the washers when the reservoir is empty. This could cause damage to the washer pump. ◀

The system sprays washer fluid against the windshield and activates the wipers for a brief period.

When the vehicle's lighting system is switched on, the headlamps will also be cleaned at reasonable intervals.

Windshield washer nozzles

The windshield washer jets are warmed automatically when the ignition key is in position 2.

Cruise control

Starting at about 20 mph / 30 km/h, you can maintain and store any vehicle speed that you specify.

The cruise control is operational whenever the engine is running and the system has been activated.

To activate the system

1/0

With the ignition key in position 2 or higher:

Press the button. The indicator lamp in the instrument cluster comes on, refer to page 20. You can now use the cruise control.

 Do not use cruise control on twisting roads, when high traffic density prevents driving at a constant speed, or when the road surface is slick – snow, rain, ice – or loose – rocks or gravel, sand. ◀

To deactivate the system

1/0

Press button as often as you need to until the indicator lamp in the instrument cluster goes out.

Cruise control

Cruise control is also deactivated when the ignition key is in position 0.

The speed stored in memory is deleted.

To store and maintain speed or to accelerate



Press button "+" briefly:

The system stores and maintains the current vehicle speed. Every time you tap the button, the speed increases by 0.6 mph / 1 km/h.

Press and hold button "+":

The vehicle accelerates without pressure on the accelerator pedal. When you release the button, the system stores and maintains the current speed.

 If on a downhill gradient the engine braking effect is not sufficient, the controlled speed can be exceeded. Speed can drop on uphill grades if the engine output is insufficient. ◀

To decelerate



Press button "-" briefly:

When cruise control is active, every tap of the button reduces the speed by approx. 0.6 mph / 1 km/h.

Press and hold button "-":

With the cruise control active, the system automatically reduces the throttle opening to slow the vehicle. When you release the button, the system stores and maintains the current speed.

To interrupt the cruise control

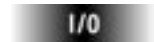

Each time you activate the system, press the button. The indicator lamp stays on. You can use the cruise control again whenever you want by calling up the speed that was stored last.

In addition, cruise control is interrupted automatically:

- ▷ If the brakes are applied
- ▷ When pressing down the clutch pedal
- ▷ If you exceed or fall below the programmed speed for an extended period – by depressing the accelerator, for example

- ▷ Sequential M gearbox SMG II, refer to page 71: when shifting in the sequential mode.

To recall the stored setting



Press button:

The vehicle accelerates to and maintains the last speed stored.



- 1 Odometer
- 2 Trip odometer

Odometer

You can activate the displays shown in the illustration with the ignition key in position 0 by pressing the left button, see arrow, in the instrument cluster.

Trip odometer

To reset the trip odometer to zero, press the left button – see arrow – with the ignition key in position 1 or higher.

Tachometer



Variable pre-warning zone

The yellow pre-warning zone displays current permissible engine speeds, depending on the engine temperature. As the engine temperature climbs, some of the sectors for this pre-warning zones will go out one after the other. Avoid engine speeds in the early warning zone if possible.

Never allow the engine to operate with the needle in the red overspeed zone of the gauge.

To protect the engine, the fuel supply is interrupted when you approach this sector.

Temperature gauge



The general operating temperature lies between 175 °F/80 °C and 250 °F/120 °C. During high-performance driving, do not exceed a maximum value of 300 °F/150 °C.

Fuel gauge



Once the indicator lamp stays on continuously, there are still approx. 2 gallons/8 liters of fuel in the fuel tank. Fuel tank capacity approx. 16.6 gal./63 liters.

If the tilt of the vehicle varies – when you are driving in mountainous areas, for example – the needle may fluctuate slightly.



Fill the fuel tank before it is completely empty. Driving to the last drop of fuel can prevent the engine from operating properly and result in damage. ◀

When you switch on the ignition, the indicator lamp lights up briefly as an operation check.

Engine coolant temperature gauge



Between the blue and red zones

Normal operating range. The needle may rise as far as the edge of the red sector during normal operation.

Blue

The engine is still cold. Drive at moderate engine and vehicle speeds.

Red

When you switch on the ignition, the warning lamp comes on briefly as an operation check.

If the lamp comes on while operating the vehicle: the engine has overheated. Switch off the engine immediately and allow it to cool down.

To check the coolant level, refer to page [126](#).

82 Service interval display



A flashing message and a "-" in front of the number mean that the service interval has already been exceeded by the distance shown on the display. Please contact your BMW center for an appointment.

Remaining distance to next service

The displays shown in the illustration appear for a few seconds when the ignition key is in position 1 or higher or after the engine is started.

The next service due appears with the message OIL SERVICE or INSPECTION, together with the distance remaining in miles – in kilometers in Canada – before the next scheduled service.

The computer bases its calculations of the remaining distance on the preceding driving style.

Check Control

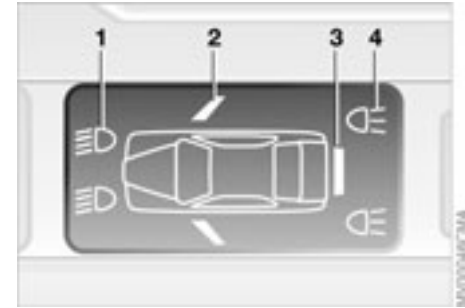

Display

When the ignition key is in position 2 or higher, the following information or conditions are displayed until the cause has been corrected:

- 1 Inspect the low-beam and high-beam headlamps, as well as the parking lamps
- 2 Door open
- 3 Luggage compartment lid open
- 4 Check brake and tail lamps

When you open the driver's door after completing a journey, an acoustic warning signal will sound if you have forgotten to turn off the headlamps.

Clock

If you wish to have a permanent time display, you can make this adjustment in the car radio* display, refer to the Owner's Manual for Radio.

You can set the time of day, and the display for the car radio, as follows.



In ignition key position 0: the time is displayed for a few seconds after you press the left button, refer to Odometer on page 80.

To adjust

When the ignition key is in position 1 or higher, the time of day appears in the display.

To set ahead: turn the right button to the right.

To set back: turn the right button to the left.

The adjustment speed will increase the longer you continue to hold the right button.

To change the display mode: press the right button briefly.

Every time you press the knob, the clock display alternates between the 12-hour and 24-hour mode.



After giving an ice warning, the display returns to the previous setting. ◀



The ice warning does not alter the fact that surface ice can form at temperatures above 37.5 °F/+3 °C, on bridges or shaded road surfaces, for instance. ◀

Mode selection

With the ignition key in position 1 and higher, you can use the button in the turn signal lever to retrieve information from the computer for display in the instrument cluster. Each time you press the button briefly in the direction of the steering column, a new function is called up in the display.

The displays appear in the following order:

Time of day, outside temperature, average fuel consumption, cruising range, average vehicle speed.

When the ignition key is in position 1 or higher, the last active setting is displayed.

Outside temperature

You can change the units of measure – °C/°F – for the outside temperature display by pressing the right-hand reset button in the instrument cluster while the temperature display is active. The units of measure – °C/°F – in the temperature display of the automatic climate control change automatically, refer to page 96.

Ice warning

If the outside temperature drops to about 37.5 °F/+3 °C, then the computer will automatically switch to a display of the outside temperature. In addition, a signal sounds as a warning and the display flashes for a brief period.

Computer



Average fuel consumption

If you continue to press and hold the button on the turn signal lever, the average fuel consumption being displayed is recalculated from that point.



If you wish, you can have the average fuel consumption displayed in a different unit of measure. ◀

Range

The computer bases its calculations of the cruising range on the preceding driving style and on the remaining fuel in the tank.



It is important that you refuel when the cruising range falls below approx. 35 miles/50 kilometers. Otherwise, the engine cannot be guaranteed to operate properly and damage may result. ◀

Average speed

If you continue to hold the button on the turn signal lever, the average fuel consumption being displayed for that speed is recalculated from that point in time.

Any time spent when the vehicle is stationary and the engine is shut off is ignored for the calculation.

The concept

PDC assists you when you back into a parking space. Acoustic signals alert you to the momentary distance to an object behind your vehicle. To do this, four ultrasonic sensors in the rear bumper measure the distance to the nearest object. The range for the sensors located at both rear corners ends approx. 2 ft/60 cm behind the bumpers. The range for the two middle sensors is slightly less than 5 ft/1.50 m.

 PDC is a parking aid that can identify objects if they are approached slowly, as is generally the case when parking. Avoid driving towards objects rapidly; due to underlying physical principles, the system may otherwise alert you too late for you to take evasive steps. ◀

The system is activated automatically about one second after you engage reverse with the ignition key in position 2.

 Let this short period elapse before driving backwards. ◀

PDC is deactivated when you shift back out of Reverse.



You can have a signal set to confirm that the PDC has been activated. ◀

Acoustic signals

The distance to the nearest object is indicated by a tone sounding at various intervals. As the distance between vehicle and object decreases, the intervals between the tones become shorter. A continuous tone indicates the presence of an object less than 1 ft/30 cm away.

The warning signal is canceled after approx. three seconds if the distance to the object remains constant during this time – if you are moving parallel to a wall, for instance.

System malfunctions will be indicated by a continuous high-pitched tone when the system is activated the first time. Please have your BMW center resolve the problem.



PDC does not remove the driver's personal responsibility for evaluating the distance between the vehicle and any objects. Even when sensors are involved, there is a blind spot in which objects cannot be detected. This applies especially in those cases where

the system approaches the physical limits of ultrasonic measurement, as occurs with tow bars and trailer couplings, and in the vicinity of thin or wedge-shaped objects. Moreover, low objects that have already been detected – such as a curb edge – can disappear out of the detection range of the sensors before a continuous tone sounds.

Loud sources of sound from outside or inside the vehicle could drown out the PDC signal tone. ◀



Keep the sensors clean and free of ice or snow in order to ensure that they will continue to operate effectively.

Do not apply high pressure spray to the sensors for a prolonged period of time. Always maintain a distance of more than 4 in/10 cm. ◀

Dynamic Stability Control (DSC)

The concept

DSC maintains vehicle stability, even in critical driving situations.

The system optimizes vehicle stability during acceleration and when starting from a full stop, as well as optimizing traction. In addition, it recognizes unstable vehicle conditions, such as understeering or oversteering, and, within physically feasible limits, helps keeping the vehicle on a steady course by reducing the engine speed and brake applications to the individual wheels.

The system starts up automatically each time you start the engine.

 The laws of physics cannot be repealed, even with DSC. The results of driving irresponsibly rest with the driver. We therefore urge you to avoid using the additional safety margin of the system as an excuse for taking

risks. Do not make any modifications to the DSC system. Allow only authorized technicians to perform service procedures on the DSC.

At first, you may need some time to become accustomed to this system's intervention. However, it guarantees optimum drive force and at the same time, the best possible vehicle stability. ◀

Indicator lamp



The indicator lamp in the instrument cluster will go out shortly after the ignition has been switched on, refer to page 19.

- ▷ Indicator lamp flashes: the system is active and is controlling the drive torque based on driving conditions
- ▷ If the indicator lamp fails to go out after the engine has been started, or if it comes on during normal driving and stays on: the system has been deactivated via the button or is defective. You can continue to drive the vehicle normally, but without DSC. Please consult your BMW center for repairs.



To deactivate the system

Press the button; the indicator lamp comes on and stays on.

The vehicle does not execute the stability-enhancement and traction-control functions when DSC is deactivated.

We recommend that you deactivate the system for increased traction:

- ▷ When rocking the vehicle or starting off in deep snow or on loose surfaces
- ▷ When driving with snow chains
- ▷ When driving on snow-covered grades, in deep snow, or on a snow-covered surface that has been packed down from being driven on.

 To maintain vehicle stability, always drive with the system switched on whenever possible. ◀

To reactivate the system

Press the button again; the indicator lamp goes out.

Dynamic Brake Control (DBC)

DBC is an integral component of the DSC system.

If you apply the brakes rapidly, this system automatically generates maximum braking force boost and thus helps to achieve the shortest possible braking distance in panic braking situations. All of the benefits of the ABS system are exploited under these circumstances.

Do not reduce the pressure on the brake pedal for the duration of the brake application. When the brake pedal is released, the DBC is deactivated.

The concept

As you drive, the Flat Tire Monitor keeps track of pressure levels in all four tires. The system detects whenever the inflation pressure in a tire drops off significantly.

Controlling the tire pressure is based on monitoring the rpm that the tires have relative to each other. A flat tire is detected and reported because the rpm suddenly deviate drastically from one another.

Flat Tire Monitor



Initializing the system

Initializing is necessary to familiarize the system with the correct inflation pressures.

Repeat this process after any changes in tire inflation pressure, tire rotation or replacement.

1. Check the tire inflation pressures in all the tires, comparing them with the inflation pressure table, refer to page 25, and adjust them if necessary
2. Turn the ignition key to position 2
3. Press button as long as you need to until the indicator lamp in the instrument cluster lights up. After a little while, the indicator lamp will go out by itself

4. After a few minutes, the Flat Tire Monitor will accept the current inflation pressure as the value to be measured against, and from that point on can detect and report a flat tire.



To activate/deactivate the system

The system is automatically activated in ignition key position 2 and consequently is on whenever the vehicle is operated.

To deactivate the system: tap the button, the indicator lamp will light up yellow.

To activate the system: tap the button again; the indicator lamp goes out.

Deactivate the system when snow chains are mounted, since false warnings and undetected losses in pressure are possible under these kinds of conditions.

Flat tire

The red warning lamp in the instrument cluster lights up to warn of pressure loss and tire failure. In addition, an acoustic signal is sounded. To come to an immediate stop, reduce speed, while avoiding any sudden, jerky braking or steering maneuvers.

Fix the flat tire using the M Mobility system, refer to page [139](#).

To reset the indicator lamp: the red indicator lamp has to be switched off manually after putting on a new wheel. At this point, hold the Flat Tire Monitor button down until the indicator lamp goes out. Reinitialize the system afterward.



The Flat Tire Monitor cannot provide you with advance warning of sudden and severe tire damage caused by external factors.

Another factor which the Flat Tire Monitor does not recognize is the balanced and very gradual pressure loss that takes place in all tires over an extended period of time. ◀



Check tire inflation pressures on a regular basis, correcting them as necessary, refer to page [25](#).

Under certain circumstances, there may be false warnings or a delayed detection of losses in pressure when driving on snow-covered or slippery road surfaces.

Performance-oriented driving – slip at the drive wheels and high levels of lateral acceleration – can also delay the appearance of status reports in the Flat Tire Monitor's display panel. ◀

System malfunctions

As long as there is still a malfunction, the indicator lamp in the instrument cluster will stay lit up yellow.

Please contact your BMW center for additional information.

M Engine dynamics control



The Sport mode is deactivated every time the engine is started.

The system – Sport mode – will cause the engine to respond more spontaneously to any motion of the accelerator pedal.

Activating/deactivating Sport mode

Activating: with the ignition key in position 2, press the SPORT button. The indicator lamp will come on.



Each time you activate the system, the vehicle may gain speed without any additional pressure on the accelerator pedal. ◀

Deactivating: press the SPORT button again; the indicator lamp will go out.



Parking lamps

 The front, rear and side vehicle lighting is switched on. You can use this to signal the position of the vehicle when it is parked. For lighting on one side for parking as an additional feature, refer to page 93.

Low beams

 When you switch the ignition off with the low-beam headlamps on, only the parking lamps will remain on.

Follow me home lamps

When you activate the headlamp flasher after parking the vehicle and switching off the lights, the low beams will come on for a brief period.

 You can also have this function deactivated. ◀

LIGHTS ON warning

Whenever you open the driver's door after having turned the ignition key to position 0, you will hear an acoustic signal for a few seconds to remind you that the lamps have not been switched off.

Daytime driving lamps*

If you desire, the light switch can be left in the low-beam position: when the ignition is switched off, the external lighting is also switched off.

Observe the legal regulations regarding the use of daytime driving lamps.

When required, switch on the parking lamps as usual as described under Parking lamps.

 You can have the activation settings for the daytime driving lamps programmed on your vehicle. ◀

Automatic headlamp control*

 When the switch is in this position, the system automatically responds to changes in ambient light – in tunnels, at dusk, etc. – and to rain and snow by switching the low beams on or off.

 The vehicle's external lamps remain on constantly when you switch on the front fog lamps after the headlamps have come on automatically. ◀

 Automatic headlamp control cannot serve as a substitute for your personal judgement in determining when the lamps should be switched on. For example, the sensors are not able to detect fog. In such situations switch on the lamp manually, as otherwise a safety hazard will result. ◀

 You can have the sensitivity of your vehicle's automatic headlamp control adjusted. ◀

Instrument lighting

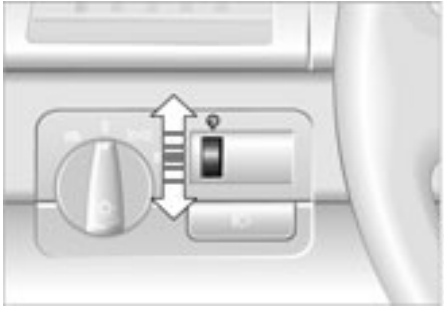

Turn the rotary dial to control the lighting when the parking or low beam lamps are on.

High beams/Standing lamps



- 1 High beams – blue indicator lamp
- 2 Headlamp flasher – blue indicator lamp
- 3 Standing lamps

Standing lamps, left or right

As an additional feature, you can illuminate your vehicle on either side for parking, if you wish to do so:

With the ignition key in position 0, push the lever in the appropriate direction. The lever engages in the turn signal position.



Front fog lamps



The green indicator lamp in the instrument cluster lights up to indicate that the front fog lamps are on.



If the automatic headlamp control is on, the low beams will come on automatically whenever you activate the front fog lamps. ◀

Interior lamps



The interior lamps operate automatically.

To switch the interior lamps on and off manually

Press the button briefly.

If you want the interior lamps to remain off all the time, press and hold the button for approx. three seconds.

Press the button briefly to revert to normal operation.

Reading lamps



Front reading lamps

Switch on and off with the button adjacent to each lamp.

Reading lamps



Rear reading lamps

With the hardtop reading lamps are also located in the rear, refer to page 113. Switch on and off with the button adjacent to each lamp.

 In order to prevent battery discharge, all of the lamps in the vehicle are automatically switched off approx. 15 minutes after you turn the ignition key to position 0. ◀

96 Automatic climate control

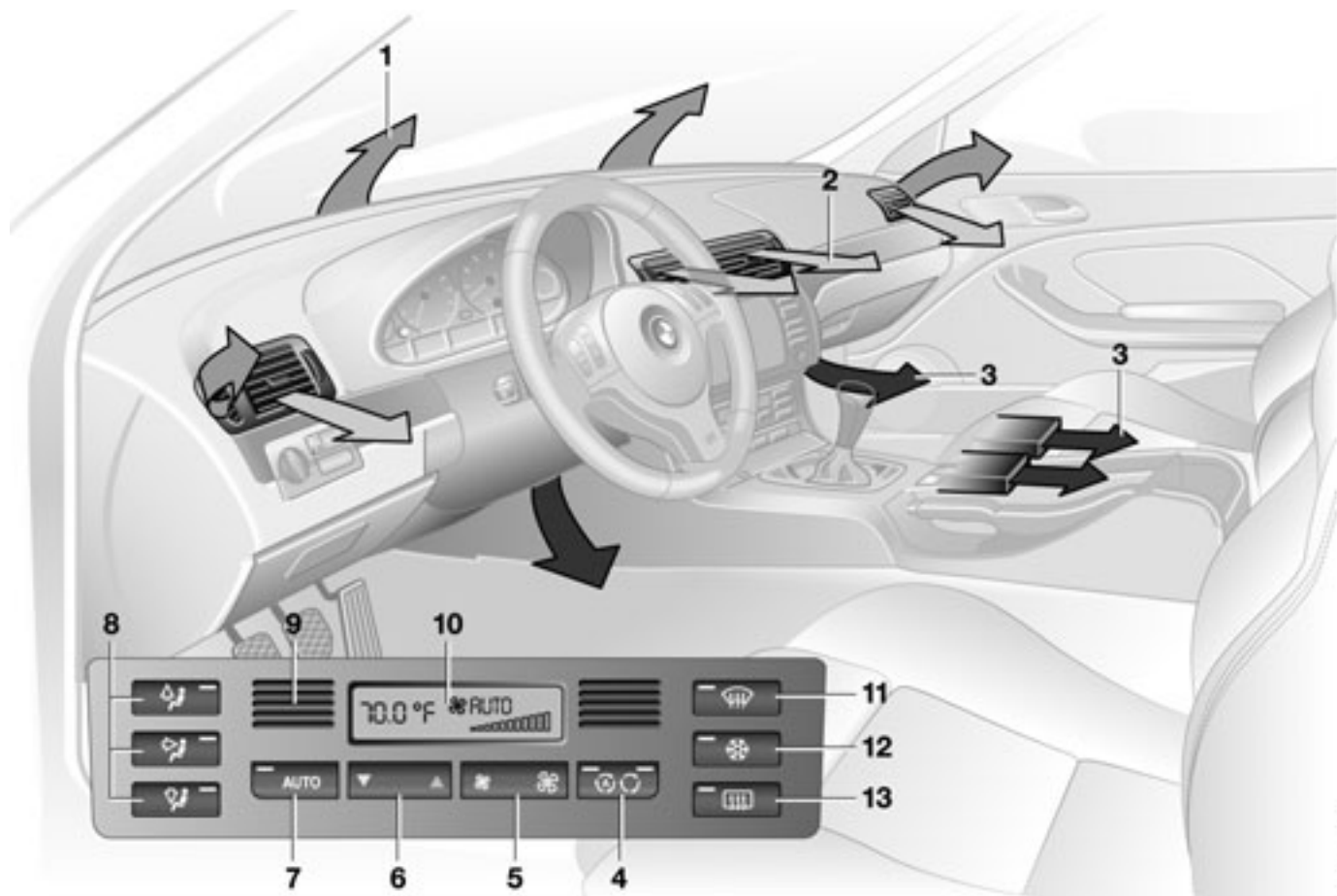

Automatic climate control

- 1 Air onto the windshield and the side windows
- 2 Air for the upper body area [99](#)
- 3 Air to the footwell
- 4 Outside air/Automatic recirculated-air control (AUC)/Recirculated air [99](#)
- 5 Air supply/Blower [98](#)
- 6 Temperature [98](#)
- 7 Automatic air distribution and supply [98](#)
- 8 Individual air distribution [98](#)
- 9 Interior temperature sensor – please keep clear and unobstructed
- 10 Display for temperature and air supply [98](#)
- 11 To defrost windows and remove condensation [98](#)
- 12 Air conditioning [98](#)
- 13 Rear window defroster [99](#)

Tips for pleasant driving

Use the automatic mode – switch on with AUTO button 7. Select the desired interior temperature.

Detailed setting options are described for you in the following sections.





You can make the settings of your vehicle in such a manner that, when you unlock the vehicle with the remote control of your personal key, your own personalized setting for the automatic climate control is initiated. ◀

Automatic air distribution and supply

The AUTO program adjusts the air distribution and the air supply for you and in addition adapts the temperature to external influences – summer, winter – to meet preferences you can specify.

Individual air distribution

You can cancel the AUTO program by selecting specific distribution patterns to suit your own individual requirements. While the AUTO program is then deactivated, the automatic airflow control remains in operation. Air flows onto

the windows , toward the upper body , and into the footwell . You can reactivate the automatic air supply by pressing the AUTO button.

Temperature

The interior temperature that appears in the display panel is a general figure intended for reference purposes. We recommend 72 °F / +22 °C as a comfortable setting, even if the air conditioning is on. When you start the vehicle, the system ensures that the selected temperature is reached as quickly as possible. It then maintains this temperature, regardless of the season.

To select the units of measure °C/°F of the display, refer to page 84.

Air supply/Blower

By pressing the left or right half of the button, you can vary the air supply. This deactivates the automatic air supply – the AUTO display disappears from the panel. Nevertheless, the automatic air distribution remains unchanged. You can reactivate the automatic air supply by pressing the AUTO button.

When the lowest blower speed is set and you press the left half of the button, all of the displays are canceled: the blower, heating and air conditioner are switched off, and the air supply is stopped. You can reactivate the system by pressing any button for the automatic climate control.

To defrost windows and remove condensation

This program quickly removes ice and condensation from the windshield and the side windows.

Air conditioning

The air is cooled and dehumidified and – depending on the temperature setting – rewarmed.

Depending on the weather, the windshield may fog over briefly when the engine is started. Air conditioning helps prevent the windows from fogging up.



Condensation forms during operation of the air conditioning system, which then exits under the vehicle. Traces of condensed water of this kind are thus normal. ◀

Automatic climate control

Outside air/Automatic recirculated-air control (AUC)/ Recirculated air



You can respond to unpleasant external odors or pollutants by temporarily stopping the flow of outside air. The system then recirculates the air currently within the vehicle.

By repeatedly pressing the button, you can select one of three different operating modes.

- ▷ Indicator lamps off: outside air always flowing into the vehicle
- ▷ Left-hand indicator lamp on – automatic mode: the system detects pollutants in the outside air and responds by deactivating the outside airflow as required. The system then recirculates the air currently within the vehicle. Depending on air quality requirements, the system automatically switches between outside air supply and recirculation of the air already within the vehicle
- ▷ Right-hand indicator lamp on: the flow of outside air is permanently blocked. The system recirculates the air already within the vehicle.



If the windows fog over in the recirculated-air mode, switch the recirculated-air mode off and increase the air supply as required. ◀

Rear window defroster



With the convertible top closed or with the hardtop* mounted, press the button. The indicator lamp remains on. The rear window defroster switches off automatically.



You can have your vehicle programmed in such a way that the rear window defroster switches on automatically. This occurs within 5 minutes after starting the engine when outside temperatures are below approx. 39 °F / +4 °C. ◀

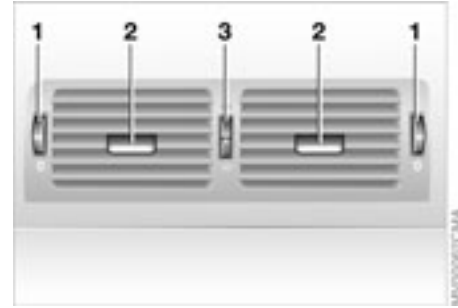

Draft-free ventilation

You can adjust the blower controls for the upper body area to obtain the optimum airflow rates and directions for your personal requirements:

- 1 Rotary dials for opening and closing the vents at any setting desired
- 2 Lever for adjusting airflow direction
- 3 With the rotary dial you can adjust the temperature of the outgoing air:
 - ▷ Turn toward blue – colder
 - ▷ Turn toward red – warmer

Microfilter, activated-charcoal filter

The built-in microfilter removes dust and pollen from the incoming air. The activated-charcoal filter provides additional protection by filtering gaseous pollutants from the outside air. Your BMW center will replace the combined filter as a standard part of your scheduled maintenance. A substantial reduction in airflow indicates that the filter needs to be replaced early.

Glove compartment



 If – for example for valet parking – you turn over only your door and ignition key, refer to page 30, then access to the glove compartment and the luggage compartment is not possible. ◀

To open

Pull the handle. The glove compartment will light up.

To close

Fold up cover.



To prevent injury in the event of an accident, close the glove compartment immediately after use. ◀

To lock

Lock with one of the master keys. A master key can also be used for unlocking.

Storage compartments 101



Front center armrest

To open: press the button and lift upward – see arrow.

Other compartments and nets

You will find additional storage areas in the doors and in the center console above the ashtray. Storage nets are located on the backrests of the front seats.

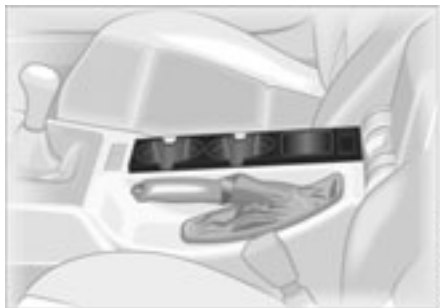

Beverage holder, coin box

A coin box and two beverage holders are provided in the center console.



Hands-free system

In vehicles equipped with telephone preparation* or with the communications package*, the cover for the hands-free microphone is located above the interior rearview mirror on the driver side.

For further information on the cellular phone, refer to the separate Owner's Manual.



To empty

Press on the edge of the open cover – see arrow: you can now pull the ashtray upward for removal.

Extinguishing cigarettes

Tap off the ash and gently press the tip into the funnel.

Cigarette lighter



Hold or touch the hot cigarette lighter by the knob only. Holding or touching it in other areas could result in burns.

The cigarette lighter remains operational when the ignition key has been removed. For this reason, children should never be left in the vehicle unattended. ◀

Ashtray, front*

Press lighter 1 in. As soon as the lighter jumps back out, it can be removed.

Cigarette lighter socket

It can be used for attaching power supplies for flashlights, car vacuum cleaners and other similar appliances up to a rating of approx. 200 watts at 12 volts. Avoid damaging the socket due to inserting plugs of different shapes or sizes.

Ashtray, rear*

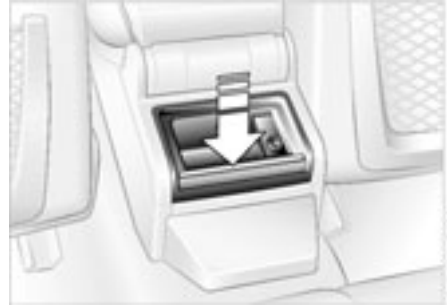

To empty

Press on the edge of the raised cover in the opening direction – see arrow. You can now pull the ashtray upward for removal.

104 **Ski bag***

The ski bag allows the safe and clean transport of up to 3 pairs of standard skis or up to two snowboards.

The length of the ski bag and the additional space provided in the luggage compartment make it possible to carry skis up to 6 ft 10 in / 2.10 m long.

Because of the tapered shape of the bag, only two pairs of skis longer than 6 ft 10 in / 2.10 m can be carried.

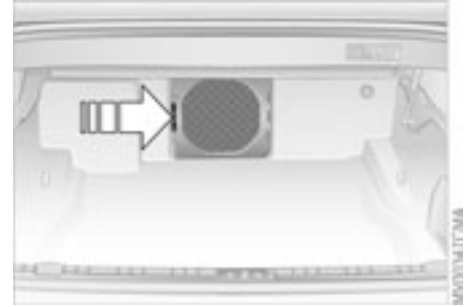

Loading

1. Release the safety belts from their holders
2. Press lever downward – see arrow – and remove the center piece by pulling it forward
3. Extend the ski bag between the front seats. The zipper provides convenient access to stored items. It may be opened to allow the ski bag to dry
4. Press the release button in the luggage compartment – see arrow



5. Secure the cover panel with the magnetic retainer on the rear wall and pull out the ski bag.

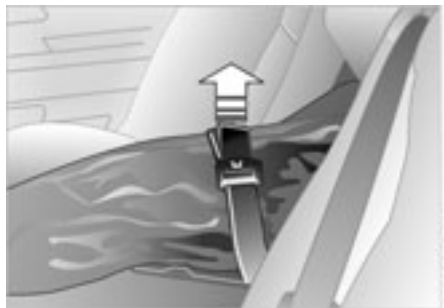

Securing cargo

 Secure skis and any other objects stored in the bag by tightening the retaining strap at the buckle. ◀

 Please be sure that the skis are clean before loading them into the bag. Be careful to avoid damage from sharp edges. ◀



Storing the ski bag

To store the ski bag, perform the above steps in reverse sequence.

 When reattaching the center piece, guide both bars into the guide and press the center piece back into place. Secure the safety belts in their holders again. ◀

 Always position and secure the load correctly. If you do not, it can endanger the passengers during braking or evasive maneuvers.

Do not exceed the approved gross weight or the approved maximum axle loads, refer to page 152. Otherwise the vehicle's operating safety is no longer assured and you are in violation of the law

Do not stow heavy or hard objects in the passenger compartment without first securing them. Otherwise they would be thrown around during braking and evasive maneuvers and endanger the occupants. ◀

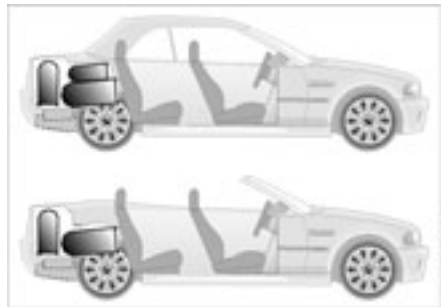

Stowing cargo

- ▷ Load heavy cargo as far forward as possible – directly behind the backrests or the luggage compartment partition – and as low as possible
- ▷ Cover sharp edges and corners.

 You can enlarge the luggage compartment when the convertible top is closed, refer to page 37. To do this you have to fold the convertible top compartment panel up.

We recommend that you always fold the convertible top compartment panel down as soon as you have removed your cargo from the luggage compartment. This way, you can be sure that you can always operate your convertible top at any time.

Conversely, when the convertible top is closed, raise the convertible top compartment panel before stowing your cargo in the luggage compartment to avoid any damage to the convertible top compartment or your load. ◀



Securing the cargo in the luggage compartment

- ▷ For small, light items, use the rubber-lined non-skid side of the floor mat or secure with a luggage compartment net* or elastic straps, refer to page 37
- ▷ For large, heavy pieces, see your BMW center for load-securing devices*. Lashing fittings located in the luggage compartment can be used for fastening the load-securing devices.

Comply with the information enclosed with the load-securing devices.



When loading, be sure to remember not to exceed the approved roof weight or the approved gross vehicle weight or the axle loads. You will find the specifications under Technical data on page 152.

Make sure that the load is not too bulky, and attempt to distribute it evenly. Always load the heaviest pieces first so that they are at the bottom. Make sure that no objects get in the way when the luggage compartment lid is opening or closing.

Secure the roof-mounted luggage correctly and safely to prevent it from shifting or being lost during driving.

Drive smoothly and avoid sudden acceleration or braking. Do not corner at high speeds.

A special roof-rack system is available as an optional extra for your BMW. Please observe the precautions included with the installation instructions.

Anchorage

Access to the mounting points:

To fold up the cover – see arrow – please use the tool which is provided with the luggage system.

Loading and driving notes

Because roof racks raise the center of gravity of the vehicle when loaded, they exercise a major effect on its handling and steering response.



Overview

Controls and features

Operation, maintenance

Owner service procedures

Technical data

Index

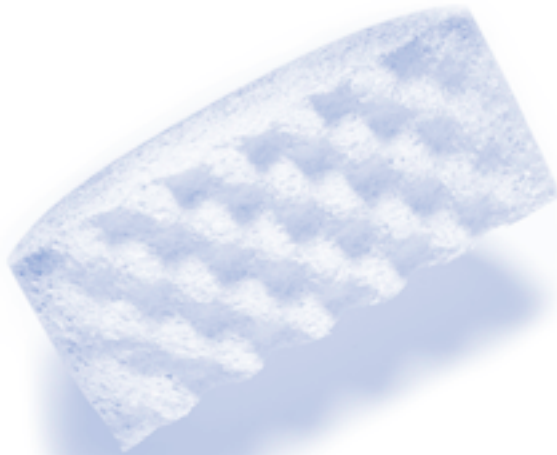

Overview

Controls

Maintenance

Repairs

Data

Index

To ensure that your vehicle provides maximum economy throughout a long service life, we request that you observe the following suggestions.



Because of its engineering design, the BMW M3 convertible is an especially high-quality vehicle. It is in your best interest to follow the break-in tips very closely. Doing this, you will create the basis for a long, optimum service life. ◀

Engine and differential

▷ Up to 1,250 miles/2,000 km: drive at varying engine and road speeds, but do not exceed the following engine or road speeds:
5,500 rpm or 105 mph/170 km/h.

Obey your local and state maximum speed limits.

Do not depress the accelerator pedal to the full-throttle position.

Vehicles with SMG II, refer to page 71: refrain from using driving program 6 in the sequential mode during the break-in period.

▷ Following the break-in inspection at 1,250 miles/2,000 km, you can gradually increase engine or road speeds.

Follow the same break-in procedure if either the engine or the differential should have to be replaced in the future.

Tires

Due to technical factors associated with their manufacture, tires do not achieve their full traction potential until an initial break-in period has elapsed. Thus drive with extra care during the initial 200 miles/300 km.

Obey your local and state maximum speed limits.



When the vehicle is operated on wet or slushy roads, a wedge of water may form between the tire and the road surface. This phenomenon is referred to as hydroplaning, and can lead to partial or complete loss of traction, vehicle control and braking effectiveness. Reduce your speed on wet roads. ◀

Brake system

Approx. 300 miles/500 km must elapse before the brake pads and rotors achieve the optimal pad-surface and wear patterns required for trouble-free operation and long service life later on.

To break in the separate parking brake drums, apply the parking brake lightly when coasting to a standstill – at a traffic signal, for instance – use caution to avoid posing a danger to other road users.

To avoid corrosion, repeat this procedure from time to time.



The brake lamps do not come on when the parking brake is set. Vacuum for the brake system servo unit on your BMW is available only when the engine is running. When you move the vehicle with the engine off – when towing, for example – substantially higher levels of pedal force will be required to brake the vehicle. ◀

Clutch

The clutch will also begin to function optimally after about 300 miles/500 km. Drive cautiously during this break-in period and do not press the clutch or shift at high engine speeds.

Driving notes



Brakes: do not rest your foot on the brake pedal while driving. Even light but consistent pedal pressure can lead to high temperatures, brake wear and possibly even brake failure.

Hydroplaning: when driving on wet or slushy roads, reduce road speed. If you do not, a wedge of water can form between tires and road surface. This phenomenon is referred to as hydroplaning, and can lead to partial or complete loss of traction, vehicle control and braking effectiveness.

Driving through water: do not drive through water on the road if it is deeper than 1 ft/30 cm, and then only at walking speed. Otherwise, the vehicle's engine, the electrical systems and the transmission may be damaged. ◀

Antilock Brake System (ABS)

The concept

The Antilock Brake System (ABS) keeps the wheels from locking during braking, thereby enhancing active driving safety.

Braking with ABS

If you are in a situation that requires full braking, you will exploit the full benefits of the ABS system if you apply maximum pedal pressure, panic stop. Since the vehicle maintains steering responsiveness, you can avoid possible obstacles with a minimum of steering effort, despite the full brake application.

Pulsation at the brake pedal combines with sounds from the hydraulic circuits to indicate to the driver that ABS is in its active mode.

Cornering Brake Control (CBC)

CBC is an advanced engineering design of the ABS. When braking while cornering at high speed or braking during high lateral acceleration, or when braking during a lane change, vehicle stability is improved and steering response is enhanced.

Brake fluid level

Low brake fluid level in the reservoir combined with longer than usual pedal travel may indicate a defect in one of the brake system's hydraulic circuits.

 Proceed to the nearest BMW center. Higher brake application pressure may be necessary when stopping, and the vehicle may exhibit a slight tendency to pull to one side. Brake distances may even be longer. Please remember to adapt your driving style accordingly. ◀

Disc brakes

When the vehicle is driven only occasionally, during extended periods when the vehicle is not used at all, and in operating conditions where brake applications are less frequent, there is an increased tendency for corrosion of the rotors and accumulation of contamination on the brake pads. This occurs because the minimal pressure that must be exerted by the pads to clean the rotors by brake applications is not reached.

Corrosion on brake rotors is signaled by a running or pulsation during braking; even extended subsequent braking will not cure this phenomenon.

It is a good idea to periodically dry the brakes with a gentle application when driving in rain and on wet roads. Watch traffic conditions to ensure that this maneuver does not endanger other road users. The heat generated in this process helps dry the pads and rotors to ensure that your brake system will respond with undiminished efficiency when you need it.

Extended or steep mountain descents should be driven in the gear in which only minimal periodic brake applications are required. This helps avoid placing excessive loads on the brake system. Stay within the allowable rpm range. For additional information, refer to page 80.

 Do not coast with the clutch depressed or with the gearshift lever in idle. Do not coast with the engine switched off. If you do so the engine provides no braking effect and there is no power assist for braking or steering when the engine is not running. ◀

Brake pads

 For your own safety: use only brake pads which BMW has approved for your specific vehicle model. BMW cannot evaluate non-approved brake pads to determine if they are suitable for use, and therefore cannot ensure the operating safety of the vehicle if they are installed. ◀

Hardtop*

It is not necessary to remove the fabric top even in the winter, when the hardtop is generally in constant use. But you can also remove it at any time with no problem. Before the fabric top is stored in the convertible top compartment, it must be absolutely dry in order to avoid water spot and mildew from forming.

The hardtop offers reading lamps and clothing hooks that can be used just by pressing. In addition, a roof-rack assembly is possible. In this regard, please contact your BMW center.

 When suspending articles of clothing from the hooks, be sure that they will not obstruct the driver's vision. Do not hang heavy objects on the hooks. If you do so, they could cause personal injury during braking or evasive maneuvers. ◀

Two people are required for installation or removal. Work with extreme caution in order to avoid paint damage and damage to the body or hardtop.

To facilitate hardtop installation or removal, you can obtain a specially designed hardtop lift* or hardtop rack* at your BMW center.



Storage

 Storing the hardtop on the floor: slide the styrofoam block that came with the hardtop forward to its center. The arrow on top of the styrofoam block has to be pointing upward when you are doing this. ◀

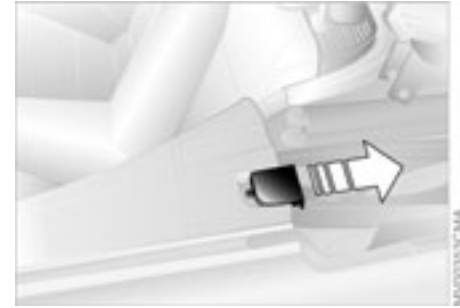

Installation

1. Lower the side windows completely and flip the sun visors down. If necessary, remove the antenna rod to avoid any damage
2. Open the convertible top compartment lid slightly by pressing the button for the convertible top operation, refer to page 42
3. Remove the trim pieces on both sides by pulling them off toward the back – see arrow – and reclose the convertible top compartment lid

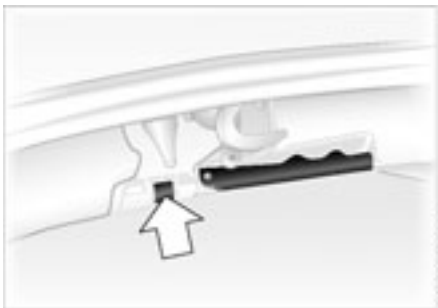

4. Raise the two front locking levers on the hardtop. Press on the buttons to do so – see arrow. The levers will release slightly. Raise the levers as far as the stop will allow

5. Before installing, first flip the cover panels that are located underneath the left and right interior lamps down. To do this, press on the slight bump on the cover panel. There is a holder in the cover panel to securely store the trim pieces that have been removed – see arrow 1

6. Open the red release lever as far as the stop will allow – see arrow 2

7. Position the hardtop onto the supports with the help of a second person. Be sure to put the mountings exactly into the proper brackets



Lift the hardtop carefully. Be extremely careful not to shift the seals. Seals that have been shifted out of place or actually pulled out cause leaks. ◀

8. In the back, close the red locking levers by turning to the inside as far as the stop located behind the trim will allow. Flip the cover panels back into place

9. To lock the hardtop in the front, keep pressing on the front locking levers until you hear it engage.

Removal

Follow the same procedure as when installing, just reverse the steps.

Tire inflation pressure

Information for your safety

The factory-approved tires are matched to your vehicle and have been selected to provide optimum safety and driving comfort when used properly.

It is not merely the tire's service life, but also driving comfort and – above all else – driving safety that depend on the condition of the tires and the maintenance of the specified tire pressure.

 Incorrect tire inflation pressure is a frequent cause of tire damage. It also significantly influences the road-holding ability of your BMW. Check tire inflation pressures on a regular basis, refer to page 25, at least every two weeks and before beginning a longer trip. Incorrect tire pressure can otherwise lead to driving instability, tire damage and accidents. ◀

Tire condition



Tire tread – tire damage

Inspect your tires frequently for tread wear, signs of damage and for foreign objects lodged in the tread. Check the tread depth.

Tread depth should not be allowed to go below 1/8 in / 3 mm, even though the legally specified minimum tread depth is only 1/16 in / 1.6 mm.

Below 1/8 in / 3 mm tread depth, there is a great risk of hydroplaning, even at relatively moderate speeds and with only small amounts of water on the road. Tread wear indicators in the tread-groove base – see arrow – are distributed around the wheel circumference and are labeled on the tire side-

wall with TWI – Tread Wear Indicator. At a tread depth of 1/16 in / 1.6 mm, the indicators signal that the legally permissible wear limit has been reached.

 Do not drive on a deflated – flat – tire. A flat tire greatly impairs steering and braking response, and can lead to complete loss of control over the vehicle.

Avoid overloading the vehicle so that the permitted load on the tires is not exceeded. Overloading can lead to overheating and internal tire damage. You could have a blowout as a result. Unusual vibrations encountered during normal vehicle operation can indicate tire failure or some other vehicle defect. This type of problem can be caused by contact with curbs, etc. This is also true for irregularities in the vehicle's handling characteristics, such as a pronounced tendency to pull to the left or right. Should this occur, respond by immediately reducing your speed. Pro-

ceed carefully to the nearest BMW center or professional tire center, or have the vehicle towed in to have it, its wheels or its tires inspected.

Tire damage, up to and including blow-outs, can endanger the lives of both the vehicle occupants and other road users ◀

Tire replacement

DOT quality grades

- ▷ Treadwear
- ▷ Traction AA A B C
- ▷ Temperature A B C



All passenger car tires must conform to Federal Safety Requirements in addition to these grades. ◀

Tread wear

The treadwear grade is a comparative rating based on the wear rate of the tire when tested under controlled conditions on a specified government test course.

For example, a tire graded 150 would wear one and one-half – $1\frac{1}{2}$ – times as well on the government course as a tire graded 100. The relative performance of tires depends upon the actual conditions of their use, however, and may depart significantly from the norm due to variations in driving habits, service practices and differences in road characteristics and climate.

Traction

The traction grades, from highest to lowest, are AA, A, B and C.

Those grades represent the tire's ability to stop on wet pavement as measured under controlled conditions on specified government test surfaces of asphalt and concrete. A tire marked C may have poor traction performance.



The traction grade assigned to this tire is based on straight-ahead braking traction tests, and does not include acceleration, cornering, hydroplaning, or peak traction characteristics. ◀

Temperature

The temperature grades are A – the highest – B and C, representing the tire's resistance to the generation of heat and its ability to dissipate heat when tested under controlled conditions on a specified indoor laboratory test wheel.

Sustained high temperature can cause the material of the tire to degenerate and reduce tire life, and excessive temperature can lead to sudden tire failure. The grade C corresponds to a level of performance which all passenger car tires must meet under the Federal Motor Vehicle Safety Standard No. 109.

Tire replacement

Grades B and A represent higher levels of performance on the laboratory test wheel than the minimum required by law.



The temperature grade for this tire is established for a tire that is properly inflated and not overloaded. Excessive speed, under-inflation, or excessive loading, either separately or in combination, can cause heat buildup and possible tire failure. ◀

Uniform Tire Quality Grading

Quality grades can be found where applicable on the tire sidewall between tread shoulder and maximum section width. For example:

Treadwear 200 Traction AA

Temperature A

Tire age

The date on which the tire was manufactured is indicated by the code on the sidewall:

DOT ... 3502 indicates that the tire was manufactured in week 35 of the year 2002.

BMW recommends the replacement of all tires when the tires are no more than 6 years old, even if a tire life of 10 years is possible.

Following wheel/tire changes

Following wheel and/or tire changes you will need to reinitialize both the Flat Tire Monitor and the sequential M gearbox SMG II, refer to pages [75](#), [89](#).

The right choice

 BMW recommends using only wheels and tires that have been approved by BMW for use on your particular model. Although other wheels and tires may theoretically have the same dimensions, variations in factors such as manufacturing tolerances can result in contact between tire and bodywork, ultimately leading to serious accidents. If non-approved wheels and tires are used, BMW cannot evaluate their suitability, and therefore cannot be held liable for driving safety. ◀

BMW tests certain tire brands for each tire size, classifies them as road-safe and approves them. Consult your BMW center for more information. Observe any country-specific regulations, e.g. on making a corresponding entry in the vehicle documents.



The correct wheel and tire combination affects different systems such as ABS, DSC, Flat Tire Monitor. The function of these systems is impaired if improper wheel and tire combinations are used. Therefore, only use tires of the same brand and same tread configuration on the vehicle and, for example following a tire failure, restore the approved wheel and tire combination as soon as possible. ◀



The use of rims and lug bolts that do not meet the specifications of the original factory-installed equipment will affect the safe operation of your vehicle and may cause an accident and personal injury. Never mix tires of different design, such as steel-belted radials with radial bias-belted or bias-ply tires, etc. Mixing tire types will adversely affect roadholding and can lead to loss of vehicle control. ◀

Storage

Store wheels and tires in a cool, dry place, protecting them against light whenever possible. Protect the tires against contact with oil, grease and fuel.

Winter tires**Choosing the right tire**

BMW recommends winter tires – M+S tires – for operation under inclement winter driving conditions. While all-season tires – M+S designation – provide better winter traction than the corresponding summer tires, they generally do not achieve the performance of winter tires.

In the interest of safe tracking and steering response, install radial tires made by the same manufacturer and with the same tread configuration on all four wheels if you elect to mount winter tires.



When mounting winter wheels, observe the different recesses of the front and rear wheels, as otherwise damage may result. ◀

Winter tires

Do not exceed specified maximum speeds



Never exceed the maximum speed for which the winter tires are rated.

Unprofessional attempts by laymen to service tires can lead to damage and accidents.

Have this work performed by skilled professionals only. Your BMW center will be glad to assist you with both their expertise and the proper equipment for your vehicle. ◀

Tire condition, tire pressure

At tread depth below approx. 3/16 in / 4 mm, their performance under winter driving conditions deteriorates noticeably. Worn tires should therefore be replaced for safety considerations.

Comply with the specified tire inflation pressures – and be sure to have the wheel and tire assembly balanced every time you change a tire or wheel.

Snow chains*

Only certain snow chains have been tested by BMW and determined and approved as roadworthy. Consult your BMW center for more information. BMW recommends using only these approved fine-link snow chains. Use them in pairs on winter tires, but only on both rear wheels.

Comply with all manufacturer's safety precautions when mounting the chains. Do not exceed a speed of 30 mph / 50 km/h with snow chains.

After mounting or removing snow chains, always reinitialize the sequential M gearbox SMG II, refer to page 89.



It is not possible to mount snow chains on tires with 18- and 19-inch wheels.

Deactivate the Flat Tire Monitor when using snow chains. Malfunction warnings and undetected losses in pressure are a possibility when driving with snow chains.

For additional information, refer to page 88. ◀

**To release**

Pull the lever located under the left-hand side of the instrument panel.

 Do not attempt to service your vehicle if you do not have the required technical background. Failure to work in an informed, professional manner when servicing components and materials constitutes a safety hazard for vehicle occupants and other road users. If you are not familiar with the guidelines, please have the operations performed by your BMW center. ◀

**To open**

Pull the release handle and open the hood.

 It is not possible to drive off using SMG II when the hood is open. ◀

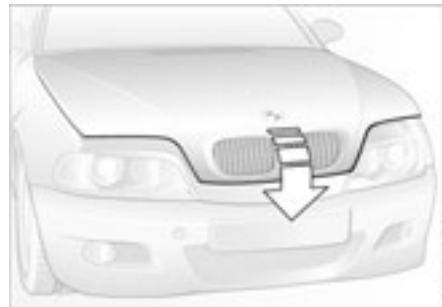
**To close**

Pull the hood downwards and allow the hood to fall from a minimum height of 1 ft/30 cm so that it audibly engages. Check for proper locking by pulling on the hood at the left and right above the headlamps.

 To avoid injuries, be sure that the travel path of the hood is clear when it is closed, following the same safety precautions used in all closing procedures. If you notice while driving that the hood is not completely closed, stop immediately and close it securely. ◀

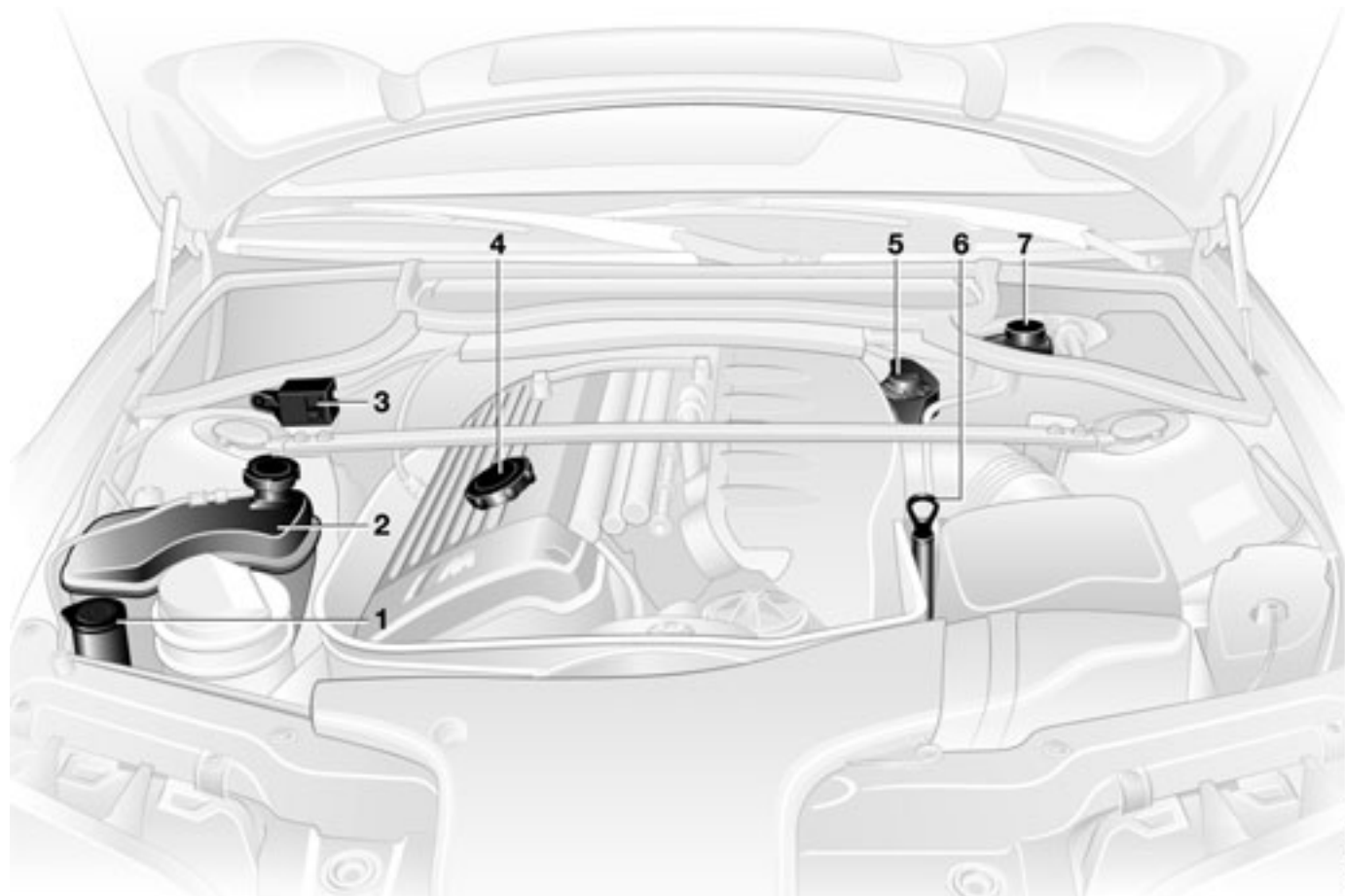

- 1 Filler neck for windshield and headlamp washer cleaning system [124](#)
- 2 Coolant expansion tank [126](#)
- 3 Positive terminal connection for jump-starting – positive terminal [145](#)
- 4 Engine oil filler neck [125](#)
- 5 Expansion tank for SMG hydraulic unit – checking and possible refilling by your BMW center [71](#)
- 6 Engine oil dipstick [124](#)
- 7 Filler neck for brake fluid [127](#)



Headlamp* and windshield washer system

Capacity approx.
5.6 US quarts/5.3 liters.

Fill with water and – if required – with a washer antifreeze additive according to manufacturer's recommendations.



We recommend that you mix the washer fluid before adding it to the reservoir. ◀



Antifreeze agents for the washer fluid are highly flammable. For this reason, keep them away from sources of flame and store them only in their closed original containers, inaccessible to children. Comply with the instructions on the containers. ◀

Engine oil

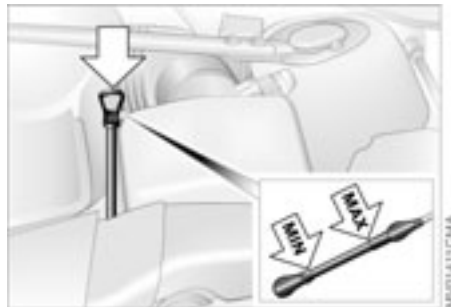

The oil volume between the two marks on the dipstick corresponds to approx. 1.4 US quarts/1.3 liter.

Checking the oil level

1. Park the vehicle on a level surface
2. Switch the engine off after it has reached normal operating temperature
3. After approx. 5 minutes, pull the dipstick out and wipe it off with a clean lint-free cloth, paper towel, or similar material
4. Carefully push the dipstick all the way into the guide tube and pull it out again
5. The oil level should be between the two marks on the dipstick.

As with fuel economy, oil consumption is directly influenced by your driving style and vehicle operating conditions.

Engine oil



Adding engine oil

While you should wait until the level has dropped to just above the lower mark before adding oil, you should never allow the oil level to fall below this mark.

Do not fill beyond the upper mark on the dipstick. Excess oil will damage the engine.

Before checking the engine oil level after topping up, restart the engine and allow it to run to obtain a correct display. Then proceed as described under Checking the oil level.

 BMW engines are designed to operate without oil additives; the use of additives could lead to damage in some cases. This also applies to the manual transmission, the differential, and the power steering system. ◀

Recommendation: have the oil changed by your BMW center only.

 Continuous exposure to used oil has caused cancer in laboratory testing. For this reason, thoroughly wash any areas of skin that come into contact with oil using soap and water. Always store oils, grease and similar materials so that they are inaccessible to children. Comply with warning labels and information on containers. ◀

 Comply with the applicable environmental laws regulating the disposal of used oil. ◀

Specified engine oils

The quality of the engine oil is extremely important for the function and life of an engine. Based on extensive testing, BMW has approved only certain grades of engine oil.

Use only oils approved for your vehicle model.

 Ask your BMW center for details concerning oils that have been approved. You can also call BMW of North America toll-free at 1-800-831-1117 or visit this website: www.bmwusa.com to obtain this information. ◀

Alternative oil types

If a High Performance Synthetic Oil approved by BMW should be unavailable, you may use small volumes of other synthetic oils for topping up between oil changes. The following data must appear on the packaging:

- ▷ Viscosity
 - preferred: SAE 10W-60
 - alternative: SAE 5W-40 or SAE 10W40
- ▷ Specifications
 - preferred: API SJ/CF
 - alternative: API SJ – also SK, SL, S etc.

Low ambient temperatures

The oils used by BMW at the factory for your vehicle model can be used at virtually any ambient temperature.

However, if the vehicle is exposed to temperatures below -4°F / -20°C for extended periods, please have your BMW center recommend a suitable oil.

Coolant



Do not add coolant to the cooling system when the engine is hot. If you attempt to do so, escaping coolant can cause burns.

Antifreeze and anti-corrosion agents are hazardous to health. You should always store them in their closed original containers and in a location inaccessible to children. Antifreeze and anti-corrosion agents are inflammable. For this reason, do not spill them on hot engine parts. They could ignite and cause burns. Comply with the instructions on the containers. ◀



Check the coolant level and add coolant

Check the coolant level when the engine is cold, approx. 68°F / $+20^{\circ}\text{C}$.

1. Open the cap for the expansion tank by turning it slightly counterclockwise to allow accumulated pressure to escape. Then open
2. The coolant level is correct when the upper end of the red float is at least even with the upper edge of the filler neck – refer to the arrow in the illustration – but no more than $3/4$ in / 2 cm above it – that is, up to the second mark on the float. Refer also to the schematic diagram next to the filler neck

Coolant

- If necessary, add coolant. If the coolant is low, slowly add coolant until the correct level is reached – do not overfill.

 Comply with the applicable environmental laws regulating the disposal of antifreeze agents with corrosion inhibitor. ◀

Brake fluid

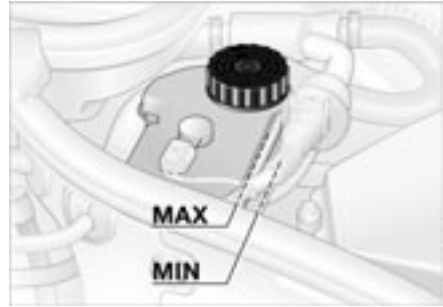

Indicator lamp

 The brake warning lamp comes on when the parking brake is not engaged: brake fluid level too low, refer to page 18.

 Brake warning lamp for Canadian models.

Adding brake fluid

For adding brake fluid or for determining and correcting the cause of brake fluid loss, consult your BMW center. Your BMW center is familiar with the specifications for factory-approved brake fluids – DOT 4.

Due to loss in brake fluid, pedal travel can lengthen and braking efficiency may be reduced. Refer to the information on page 112.

 Brake fluid is hygroscopic, that is, it absorbs moisture from the air over time.

In order to ensure the safety and reliability of the brake system, have the brake fluid changed every two years by a BMW center. Refer also to the Service and Warranty Information Booklet for US models or the Warranty and Service Guide Booklet for Canadian models. Brake fluid is toxic and damages the vehicle's paint. You should always store it in its closed original container and in a location inaccessible to children. Do not spill the brake fluid and do not fill the brake fluid reservoir beyond the MAX mark. The brake fluid could ignite upon contact with hot engine parts and cause serious burns. ◀

 Comply with the applicable environmental laws regulating the disposal of brake fluid. ◀



The BMW Maintenance System has been designed as a reliable means of providing maximum driving and operating safety – and as cost-effectively for you as possible. Please keep in mind that regular maintenance is not only necessary for the safety of your vehicle, but also plays a significant role in maintaining the resale value of the vehicle.

Service interval display

While conventional systems rely on distance traveled alone to determine when service is due, the BMW Maintenance System has for years taken the actual

conditions under which the vehicle operates into consideration, because miles can be traveled in many different ways:

For example, 62,000 miles/100,000 km short-distance driving are not equal to the same 62,000 miles/100,000 km of long-distance travel.

The BMW Maintenance System includes the Engine Oil Service and Inspections I and II.

 Have a break-in inspection performed at 1,250 miles/2,000 km regardless of the service interval indicated on the display. ◀

Determining the maintenance intervals according to the actual loads on the vehicle covers every kind of operating situation. Minimal-use drivers – who drive significantly fewer than 6,200 miles/10,000 km annually – should have the engine oil changed at least every 2 years since oil deteriorates over time, regardless of use.

Service and Warranty Information Booklet for US models/Warranty and Service Guide Booklet for Canadian models

For additional information on required maintenance intervals and procedures, please refer to the Service and Warranty Information Booklet for US models, or the Warranty and Service Guide Booklet for Canadian models.

As a precaution against corrosion, it is advisable to have the body checked for damage from rocks or gravel at the same time, depending upon operating conditions.

 Have your BMW center perform maintenance and repair. Be sure that all maintenance work is recorded in the Service and Warranty Information Booklet for US models, or in the Warranty and Service Guide Booklet for Canadian models. These entries are your verification for the regular maintenance of your vehicle and are required for the performance of warranty repairs. ◀

Care

You can find everything you need to know on this topic by consulting the separate Caring for your vehicle brochure.

130 California Proposition 65 warning

California laws require us to state the following warning:

 Engine exhaust, some of its constituents, and certain vehicle components contain or emit chemicals known to the State of California to cause cancer and birth defects and reproductive harm. In addition, certain fluids contained in vehicles and certain products of component wear contain or emit chemicals known to the State of California to cause cancer and birth defects or other reproductive harm. Battery posts, terminals and related accessories contain lead and lead compounds. Wash your hands after handling.

Used engine oil contains chemicals that have caused cancer in laboratory animals. Always protect your skin by washing thoroughly with soap and water. ◀

OBD interface socket



The Onboard Diagnostic (OBD) interface socket is located on the left of the driver's side at the bottom of the instrument panel and under a cover. The cover has the letters OBD on it.

The purpose of the OBD system is to assure proper emission-control system operation for the vehicle's lifetime by monitoring emission-related components and systems for deterioration and malfunction.

 An illuminated indicator informs you of the need for service, not that you need to stop the vehicle. However, the systems should be checked by your BMW center at the earliest possible opportunity.

OBD interface socket

If the indicator blinks or flashes, this indicates a high level of engine misfire. Reduce speed and contact your nearest BMW center immediately. Severe engine misfiring for even a short period of time can seriously damage emission-control system components, especially the catalytic converter.



Service Engine Soon warning lamp for Canadian models.



If the fuel filler cap is not on tight enough, the OBD system can detect leaking vapor and the indicator will light up. If the fuel filler cap is then tightened, the indicator will usually go out after a short period of time. ◀

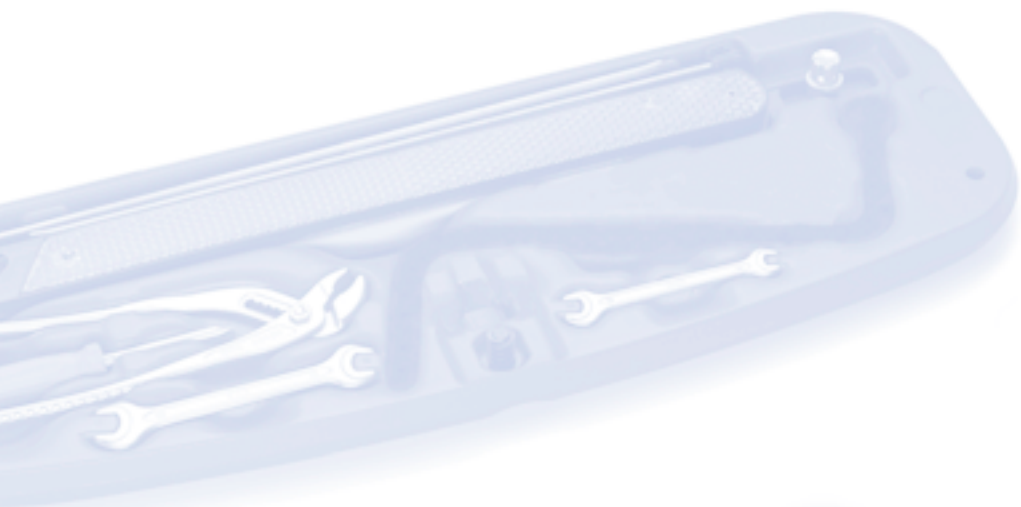



Overview

Controls and features

Operation, maintenance

Owner service procedures

Technical data

Index

Overview

Controls

Maintenance

Repairs

Data

Index



The onboard tool kit is located in the luggage compartment lid.

To open, loosen the wing nut. For storage place of towing eyelet, refer to page [146](#).



1. Switch off the engine
2. Fold the wiper arm completely out from the windshield
3. Position the wiper blade at an angle and pull the release spring – see arrow
4. Fold the wiper blade down and unhook it toward the windshield
5. Pull the wiper blade past the wiper arm toward the top
6. Insert a new wiper blade and apply pressure until you hear it engage.

Lamps and bulbs

The lamps and bulbs make essential contributions to the safety of your vehicle. Therefore, comply fully with the following instructions during bulb replacement. If you are not familiar with any of the procedures, consult your BMW center.

 Do not touch the glass portion of a new bulb with your bare hands since even small amounts of impurities burn in to the surface and reduce the service life of the bulb. Use a clean cloth, paper napkin, or a similar material, or hold the bulb by its metallic base. ◀

A replacement bulb set is available from your BMW center.

 Before working on the electrical system, switch off the electrical accessory you are working on or disconnect the cable from the negative terminal of the battery. Failure to observe this precaution could result in short circuits. To prevent injuries and damage when changing a bulb, be sure to comply with any instructions provided by the bulb manufacturer. ◀

Low beams and high beams

- ▷ Low beams: H7 bulb, 55 watts
- ▷ High beams: H7 bulb, 55 watts

 The H7 bulb is pressurized. Therefore, wear safety glasses and protective gloves. Failure to comply with this precaution could lead to injury if the bulb is damaged. ◀

Please contact a BMW center in case of a malfunction.

Parking lamps

5 watt bulb

Please contact a BMW center in case of a malfunction.

When cleaning the headlamps, please follow the instructions in the Caring for your vehicle brochure.

Xenon lamps*

The service life of these bulbs is very long and the probability of a failure is very low, provided that they are not switched on and off an unusual number of times. If one of these bulbs should nevertheless fail, it is possible to continue driving with great caution using the fog lamps, provided traffic laws in your area do not prohibit this.



Because of the extremely high voltages involved, any work on the xenon lighting system, including bulb-changing, should be carried out by technically-qualified personnel only. Otherwise, there is a risk of fatal injury. ◀



Front turn signal indicators

21 watt bulb

1. Extend a screwdriver through the upper opening loosen the screw and remove it
2. Remove lamp by pulling it out toward the front
3. Applying light pressure, turn the bulb to the left. Remove and exchange the bulb

4. Insert the 2 pins on the lamp into the guides on the vehicle
5. Slide in the lamp and screw the bulb in place through the upper opening.

Side turn signal indicators

5 watt bulb

1. Use finger pressure against the rear end of the lamp – see arrow – to press it forward for removal
2. Apply gentle pressure to the bulb while turning it to the left to remove.

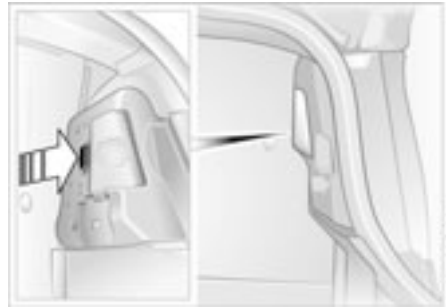

Tail lamps

- 1 Turn signal indicator
- 2 Backup lamp
- 3 Tail lamp
- 4 Tail lamp/brake lamp

Tail lamp 4: 21/4 watt bulb

Remaining bulbs: 21 watt

The illustration shows the right-hand luggage compartment opening.

Bulbs in the fender:

All of the bulbs are integrated in a central bulb holder.

1. Release the bulb holder – see arrow

2. Take out the bulb holder
3. Unplug the power supply receptacle. Set the bulb holder aside, on the luggage compartment floor, for example
4. Applying light pressure, turn the bulb to the left. Remove and exchange the bulb
5. Plug in the power supply receptacle
6. Reattach the bulb holder until you hear it snap into place – see arrow.



Bulbs in the luggage compartment lid
1. Using a screwdriver, loosen the clip

2. Fold the trim panel down – see arrow 1. Disengage the bulb holder – see arrow 2 – and remove it
3. Applying light pressure, turn the bulb to the left. Remove and exchange the bulb
4. Press the bulb holder into position until you hear it engage
5. Reinstall the trim with the clip.

Center high-mount brake lamp
LED strip in luggage compartment lid.
Please contact a BMW center in case of a malfunction.

Lamps and bulbs

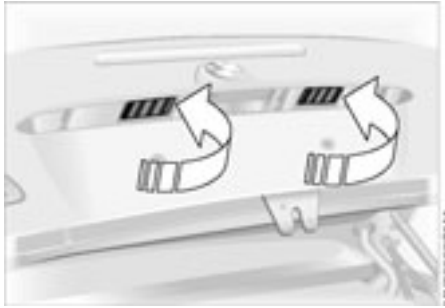

License plate lamps

5 watt bulb

1. Place a screwdriver in the slot and press toward the left – see arrow – to release the lens
2. Replace the bulb.

Repairing a flat tire



Precautions in case of a flat tire: Stop the vehicle as far as possible from passing traffic; switch on the hazard warning flashers.

Turn the steering wheel to the straight-ahead position and engage the steering lock. Shift into 1st or reverse and engage the parking brake.

All passengers should be outside the vehicle and well away from your immediate working area – behind a guardrail, for instance.

If necessary, set up your warning triangle or portable hazard warning lamp on the roadside at an appropriate distance from the rear of the vehicle. Comply with all safety guidelines and regulations. ◀

M Mobility system

You will find an M Mobility system in your BMW M3 convertible for repairing flat tires. With this system you can apply a sealing liquid to the inside of the tire that seals off the damaged point and then continue driving.

The M Mobility system makes transporting a spare wheel superfluous, thereby reducing the amount of weight you have to carry around.

Using the M Mobility system

To repair a flat tire using the M Mobility system, proceed as follows:

- ▷ Preparing the M Mobility system for use, refer to the next column
- ▷ This is part of the M Mobility system, refer to page 140
- ▷ Filling with sealant, refer to page 141
- ▷ Distributing sealant, refer to page 141
- ▷ Inflating tire to correct pressure, refer to page 142.

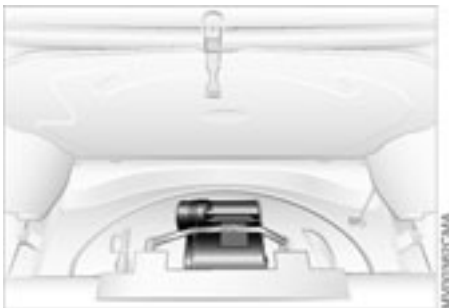

 Please keep in mind that the fluids bottle in the system's sealant container has to be changed every 3 years by your BMW center, if the unit has not been used. ◀

Preparing the M Mobility system for use

The M Mobility system is located in the luggage compartment under the floor panel:

1. Lift the floor panel
2. Loosen the M Mobility system from its storage location.

 Before you use the M Mobility system, read the warnings and danger notices on the device carefully. ◀

If possible, leave the foreign object in the tire.

Pull off the sticker 5, refer to the second column on the right, for the speed limit and apply it to the steering wheel.



This is part of the M Mobility system

- 1 On/Off switch
- 2 Connection hose with manometer for connecting the compressor with the sealant container or to connect the compressor to the wheel
- 3 Manometer for indicating the tire pressure
- 4 Connector hose from the sealant container to the wheel
- 5 Sticker with speed limit
- 6 Plug and cable for the cigarette lighter socket
- 7 Protective gloves, not shown



Filling with sealant

1. Take off the round cover and take out hose 4. Unscrew the valve dust cap from the defective wheel and screw the hose to the valve. Keep the dust cap in a safe place
2. Flip open the cover and pull out the enclosed protective gloves. Take out hose 2 with the manometer and screw it to the terminal for the sealant container as shown in the illustration
3. Make sure that the system has been switched off, position 0. Take out plug 6 and insert it into the cigarette lighter socket in the passenger compartment, refer to page [103](#)
4. Make sure that the screw on the rear of the pressure gauge 3 is tightened down. Turn on the M Mobility system, position I, refer to illustration, and allow minutes to elapse, to let the sealant flow in. It does not matter afterward, what the tire's inflation pressure is
5. Turn the system off. Disconnect the connector hose from the sealant container and the wheel valve. Stow the M Mobility system in the luggage compartment.

Distributing the sealant

Right afterward, drive at least 1 1/4 miles/2 km, so that the liquid sealant distributes evenly throughout the inside of the tire.

142 **Repairing a flat tire**

 Do not exceed a maximum speed of 40 mph / 60 km/h. If possible, keep the vehicle speed above 10 mph / 20 km/h.
Stop in a suitable spot. ◀



 Even if the tire fails to hold the pressure, you should still carry out Step 3 before proceeding to drive the vehicle again, refer to Distributing the sealant for more information. Then repeat Steps 1 through 3.
The use of the M Mobility system may be ineffective if the damaged area in the tire is larger than approx. 3/16 in / 4 mm. Please consult the nearest BMW center if the tire cannot be temporarily repaired with the M Mobility system. ◀

Inflating tire to correct pressure

1. Take out the hose with the pressure gauge and screw it onto the valve. Take the plug out and plug it into the cigarette lighter socket in the passenger compartment
2. Reset the air pressure to 29 psi/200 kilopascal, and:
 - ▷ Increase tire pressure: switch on the M Mobility System, position I. Switch off the unit briefly to check the current tire pressure
 - ▷ Decrease tire pressure: turn the screw on the back of the manometer, a valve located there will open

3. Unscrew the hose from the valve and stow the M Mobility system in the luggage compartment. Screw the dust cap onto the valve again.

 Do not exceed the maximum speed limit described below, otherwise it could lead to accidents. ◀

When you start driving again, do not exceed the permissible maximum speed of 45 mph / 80 km/h.

Repairing a flat tire

 You will find corresponding instructions for using the M Mobility system on the device. Replace the defective tire as soon as possible and have the new wheel balanced. Reinitialize the Flat Tire Monitor, and refer to page 89 for further information. Have the M Mobility system refilled. Contact your BMW center for this. ◀

Protect valve stems against dirt using screw-on dust caps. Dirty valve stems frequently lead to slow pressure loss.

Battery

 Battery posts, terminals, and related accessories contain lead and lead compounds. Wash hands after handling. ◀

Maintenance

The battery is completely maintenance-free. That means that the original battery acid will normally last for the service life of the battery under moderate climate conditions.

 Please consult your BMW center whenever you have any questions concerning the battery. Since the battery is absolutely maintenance-free, the following statements are for your information only. ◀

 Never disconnect the battery when the engine is running; the ensuing voltage surge would seriously damage the vehicle's onboard electronic systems. ◀

Charging the battery

Charge the battery in the vehicle only when the engine is not running. Use the connections provided in the engine compartment. For information on the connections, see Jump-starting, page 145.

 Return used batteries to a recycling point or your BMW center. Maintain the battery in an upright position for transport and storage. Secure the battery against tilting in transit. ◀

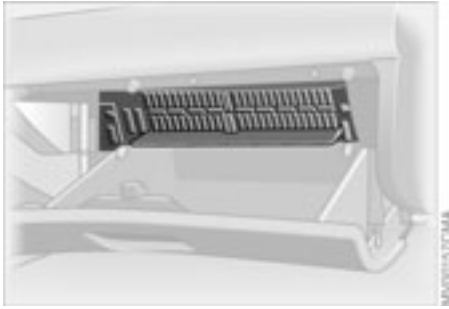

You will find the fuses and information on their respective allocation in the glove compartment behind a panel with two snap clips.



Do not attempt to repair a blown fuse or replace it with a fuse having a different color or amperage rating. To do this could cause a fire in the vehicle resulting from a circuit overload. ◀

Jump-starting

When your battery is discharged, you can use two jumper cables to start your vehicle with power from the battery in a second vehicle. You can also use the same method to help start another vehicle. Use only jumper cables with fully insulated handles on the terminal clamps.

 Do not touch high-voltage wiring and cables on a running engine. Contact with components carrying high voltage can be harmful or fatal. Carefully observe the following instructions to avoid personal injury and/or damage to one or both vehicles. ◀

1. The battery in the support vehicle must be rated at 12 volts. This information is provided on the battery label
2. Stop the engine of the support vehicle and switch off all electrical components in both vehicles – except for the hazard warning flashers of the support vehicle
3. Make absolutely certain that there is no contact between the bodywork of the two vehicles – short circuit hazard

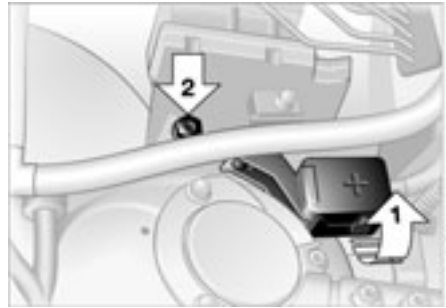

4. The auxiliary jump-starting terminal located in your BMW's engine compartment acts as the positive battery terminal. The cover of this auxiliary terminal is marked with a + sign. Remove by pulling the tab, see arrow 1. Start by connecting the jumper cable from the positive terminal of the discharged battery to the positive terminal of the support battery
5. Then connect the negative terminals with the other jumper cable. Attach the cable to either the support vehicle's negative battery terminal or to a suitable ground on its engine or bodywork. Then connect the other end to the negative battery terminal

or a suitable ground on the vehicle being started. Your BMW is equipped with a special nut for this purpose – see arrow 2

 Always adhere to this sequence when connecting jumper cables; failure to observe this procedure can lead to sparks at the battery terminals and pose an injury hazard. ◀

6. Start the engine of the support vehicle and let it run for several minutes at a slightly elevated engine idle speed
7. Start the engine of the other vehicle as usual. If the first start attempt is not successful, wait a few minutes before another attempt in order to allow the discharged battery to recharge
8. Allow the engines to run for several minutes before disconnecting the jumper cables
9. Then disconnect the jumper cables in the opposite order.

Have the battery recharged at your BMW center as required.

 Do not use spray starter fluids to start the engine. ◀

Towing eyelet

The towing eyelet, which can be unscrewed, is in the luggage compartment under the floor mat and must remain in the vehicle. This eyelet is designed for installation in the tow sockets located at the front and rear of the vehicle. It is intended for towing on paved road surfaces only.

The towing eyelet should not be used to pull a vehicle out of deep snow, mud, sand, etc.

Comply with all applicable towing laws and regulations at all times.

**Access to tow sockets**

Front:

Press out the cover panel with a screwdriver at the top of the recess.

Rear:

Press out the cover panel with a screwdriver at the top of the recess.

 Make sure the towing eyelet is firmly screwed all the way in, otherwise the thread could be damaged. Only use the towing eyelet provided in the vehicle to avoid damage. Do not tow the vehicle by any components of the running gear, or lash them down in any way. If you do, the components could be damaged, possibly leading to accidents. ◀

 Keep the vehicles in line and avoid towing at an offset angle. Ensure that the tow rope connecting the two vehicles is tight, with no slack, before starting off. ◀

Towing the vehicle

Use only a nylon towing strap to tow the vehicle, since the inherent resilience of this material helps protect both vehicles from sudden jerking movements.

 The towed vehicle should always be the lighter of the two vehicles. If this is not the case, it will not be possible to control vehicle handling. ◀

Tow-starting

For instructions on jump-starting, refer to page 145.

Never attempt to use your vehicle to push another vehicle, since damage to the energy-absorbing bumpers could result.

Towing a vehicle

1. Gearshift lever in Neutral
2. Towing speed:
Max. 45 mph / 70 km/h
3. Towing distance:
Max. 95 miles/150 km
4. Leave the ignition key at position 1 to ensure that the brake lamps, turn signal indicators, horn and windshield wipers remain operative, and to prevent the steering lock detent from engaging

5. Switch on the hazard-warning system – observe applicable legal regulations.

Find some means of identifying the vehicle in tow, for instance, place a sign or warning triangle in the rear window.

 Make sure that the ignition key remains in position 1 even when the electrical system has failed to prevent the steering lock from engaging. The steering and brakes are without power-assist when the engine is off. This means that increased effort is required for steering and braking. ◀

Vehicle with sequential M gearbox SMG II:

To push or tow, engage selector lever in position 0.

 Never work on the vehicle with a driving position engaged. ◀

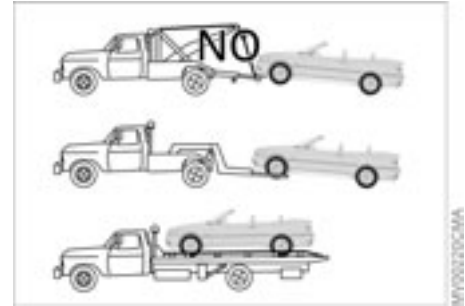

Towing with a commercial tow truck

- ▷ Do not tow with sling-type equipment
- ▷ Use wheel lift or flatbed equipment
- ▷ Please comply with applicable state towing laws.

 Never allow passengers to ride in a towed vehicle for any reason. Never attach tie-down hooks, chains, straps, or tow hooks to tie rods, control arms, or any other part of the vehicle suspension, as severe damage to these components will occur, possibly leading to accidents. ◀

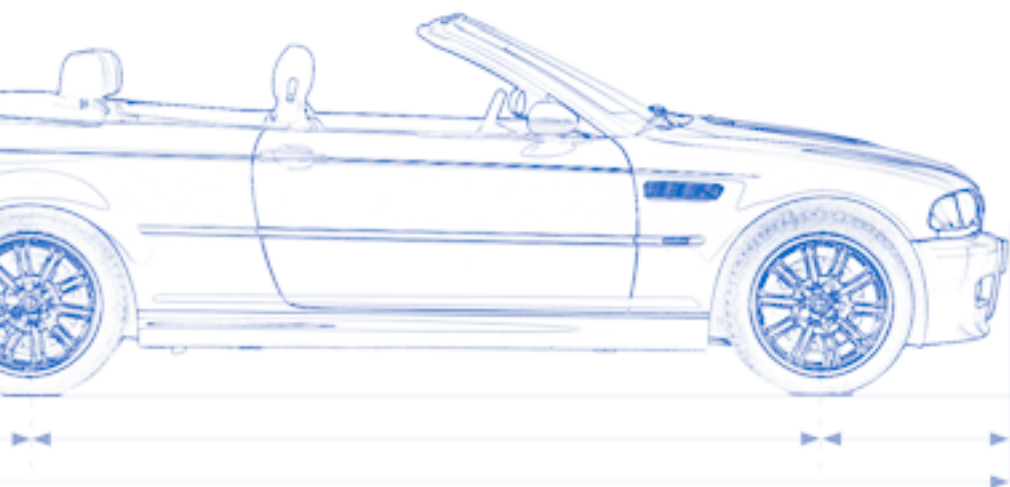

Overview

Controls and features

Operation, maintenance

Owner service procedures

Technical data

Index



Overview

Controls

Maintenance

Repairs

Data

Index

150 **Engine data**

Displacement	cu in/cm ³	198.1/3,246
Number of cylinders		6
Max. power output at engine speed	hp/kW rpm	333/248 7,900
Maximum torque at engine speed	lb ft/Nm rpm	262/355 4,900
Compression ratio	ϵ	11.5
Stroke	in/mm	3.58/91
Bore	in/mm	3.43/87
Fuel-injection system		Digital electronic engine-management system

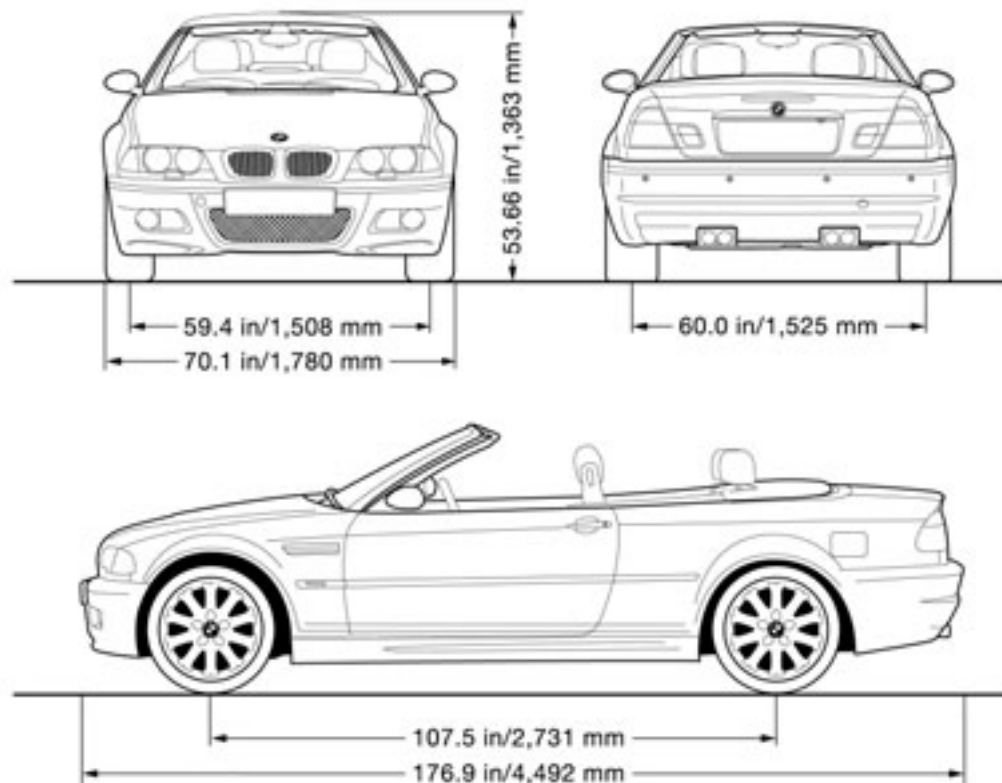

Minimum turning circle dia.: 36.1 feet/11.0 m.

152 **Weights**

Curb weight	lbs/kg	3,782/1,715
Approved gross vehicle weight	lbs/kg	4,630/2,100
Approved front axle load	lbs/kg	2,183/990
Approved rear axle load	lbs/kg	2,579/1,170
Permissible roof load for the hardtop	lbs/kg	165/75
Luggage compartment capacity with the convertible top compartment raised	cu ft/l	9.2/260 10.6/300

Approved axle loads and approved gross vehicle weight may not be exceeded.

			Notes
Fuel tank	gal./liters	approx. 16.6/63	Fuel specification: page 25
Reserve	gal./liters	approx. 2.1/8	
Windshield washer system/ Headlamp cleaning system	quarts/liters	approx. 5.6/5.3	For details: page 124
Cooling system including heater circuit	quarts/liters	approx. 9.8/9.3	For details: page 126
Engine with oil filter change	quarts/liters	approx. 5.8/5.5	For details: page 125
Manual transmission	quarts/liters	approx. 1.9/1.8	Oil change during running-in check and during each inspection II
Differential	quarts/liters	approx. 1.2/1.1	Oil change during running-in check and during each inspection II

A B C
P Q R



Overview

Controls and features

Operation, maintenance

Owner service procedures

Technical data

Index

Overview

Controls

Maintenance

Repairs

Data

Index

Everything from A to Z

A

ABS Antilock Brake System indicator lamp 19

Accessories 5

Activated-charcoal filter 100

Adding brake fluid 122, 127

Air conditioning 98

Air distribution, automatic 98

Air distribution, individual 98

Air nozzles 96

Air outlets 96

Air pressure 115
checking 25

Air supply 98

Air supply vents
recirculated-air mode 99

Airbags 57
warning lamp 18

Alarm system 38
avoiding false alarm 39
indicator lamp 39
interior motion sensor 38
tilt alarm sensor 38

Antifreeze 126

Antilock Brake System (ABS) 111
indicator lamp 19

Anti-theft system 30, 38

Armrest 101

Ashtray
front 102
rear 103

AUC Automatic recirculated-air control 99

Automatic car wash, refer to the Caring for your vehicle brochure

Automatic climate control 96

Automatic cruise control 78

Automatic dimming, interior rearview mirror 56

Automatic headlamp control 92

Automatic recirculated-air control (AUC) 99

Auxiliary terminal for jump-starting 122, 145

Average fuel consumption 85

Average speed 85

Avoiding unintentional alarms 39

Axle loads 152

B

Backrests
unlocking 51

Backup lamps 70
replacing bulb 137

Battery 143
charge 143
charge current 18
charge current lamp 18

Belts 52

Beverage holder 102

Blower 98

BMW Maintenance System 128

Bore 150

Bottle holder, see Beverage holder 102

Brake fluid level 112
warning lamp 18, 127

Brake hydraulic system
warning lamp 18

Brake lamps
replacing bulb 137

Brake pads 112

Brake system
brake fluid level, warning lamp 18
brake pads, indicator lamp 19

Brakes
malfunctions 112
parking brake 69

Braking
driving notes 111

Break-in procedures 110

Bulb replacement 135

C

California Proposition 65 warning 130

Can holder, see Beverage holder 102

Capacities 153

Car care, refer to the Caring for your vehicle brochure

Car vacuum cleaner, connecting 103

Car wash, refer to the Caring for your vehicle brochure

Care, refer to the Caring for your vehicle brochure

Cargo loading 106

Caring for headlamp covers, refer to the Caring for your vehicle brochure 135

CBC Cornering Brake Control 111
indicator lamp 19

Cellular phone 102

Center armrest 101

Center high-mount brake lamp 138

Central locking system 30
button 34

Check Control 82
CHECK FILLER CAP indicator lamp 19

Checking coolant level 126

Checking oil level 124

Child seat 59

Child-restraint systems 59

Cigarette lighter 102

Clean windshield 78

Everything from A to Z

- Cleaning position, convertible top [45](#)
- Cleaning windshield [78](#)
- Clock [83](#)
 - refer also to the radio or onboard computer
 - Owner's Manual
- Cockpit [14](#)
- Code, tires [118](#)
- Coin box [102](#)
- Compression ratio [150](#)
- Computer [84](#)
- Condensation, removing
 - from windows [98](#)
- Configure personal settings
 - Vehicle Memory, Key Memory [65](#)
- Consumption
 - display [81](#)
 - fuel [85](#)
- Convertible top
 - cleaning position [45](#)
 - electrical malfunction [44](#)
 - emergency operation [44](#)
 - opening and closing [42](#)
- Convertible top operation
 - fully automatic convertible top [41](#)
- Coolant [122](#), [126](#), [153](#)
 - indicator lamp [19](#)
- Cooling system [153](#)
- Copyright [4](#)
- Cornering Brake Control (CBC) [111](#)
- Cruise control [78](#)
 - indicator lamp [20](#)
- Cup holder, see Beverage holder [102](#)
- Curb weight [152](#)
- Cushion height [151](#)
- D**
- Data
 - dimensions [151](#)
 - engine [150](#)
 - weights [152](#)
- Daytime driving lamps [92](#)
- DBC Dynamic Brake Control [88](#)
 - warning lamp [19](#)
- Defrost position [98](#)
- Defrosting rear window [99](#)
- Defrosting windows [98](#)
- Digital clock [83](#)
- Dimensions [151](#)
- Dipstick, engine oil [124](#)
- Disc brakes [112](#)
- Displacement [150](#)
- Display lighting [93](#)
- Displays [16](#)
- Distance warning [86](#)
- Door key [30](#)
- Door lock buttons [34](#)
- Doors
 - emergency operation [33](#)
 - manual operation [33](#)
 - remote control [31](#)
 - unlocking and locking [31](#), [33](#)
- Drivelogic [74](#)
- Driving notes
 - braking [111](#)
 - disc brakes [112](#)
 - general [111](#)
 - hydroplaning [111](#)
- DSC Dynamic Stability Control [87](#)
 - indicator lamp [19](#)
- Dynamic Brake Control (DBC) [88](#)
- Dynamic Stability Control (DSC) [87](#)
 - indicator lamp [19](#)
- E**
- Electric malfunction
 - doors [33](#)
- Electric power windows [40](#)
- Electrical accessories, failure [144](#)
- Electrical malfunction
 - convertible top [44](#)
 - fuel filler door [24](#)
- Emergency operation
 - doors [33](#)
 - fuel filler door [24](#)
- Emergency release
 - luggage compartment lid [36](#)
- Engine
 - displacement [150](#)
 - output [150](#)
 - starting [67](#)
 - switching off [69](#)
 - torque [150](#)
- Engine compartment [122](#)
- Engine coolant [153](#)
 - refilling [126](#)
 - temperature gauge [81](#)
- Engine data [150](#)
- Engine electronics
 - warning lamp [19](#)
- Engine oil
 - adding [122](#), [124](#)
 - capacity [153](#)
 - consumption [124](#)
 - dipstick [124](#)
 - quality [125](#)
 - types [125](#)
 - viscosity [125](#)
- Engine oil level
 - check [122](#)
 - indicator lamp [19](#)
 - warning lamp [18](#)

Everything from A to Z

Engine oil pressure
warning lamp 18
Engine speed 150
Entering the rear 51
Exterior mirrors 55
Eyelet, towing 146

F

False alarm, avoiding 39
Fault displays 82
First-aid kit 23
Flat tire 115
repairing 139
Flat Tire Monitor 88
indicator lamp 18, 19
Fog lamps 94
Fold down convertible top
compartment panel 37
Follow me home lamps 92
Footbrake 112
Footbrake, refer to Driving
notes 111
Footwell lamps 94
Front airbags 57
Front fog lamps 94
indicator lamp 20
Front seat adjustment 49
Frost protection,
radiator 126
Fuel 25
Fuel consumption 85
display 81

Fuel filler door 24
release following an elec-
trical malfunction 24
Fuel gauge 81
Fuel specifications 25
Fuel tank capacity 153
Fuel tank display 81
Fuel tank gauge 81
Fuel-injection system 150
Fully automatic convertible
top 41
operation 41
Fuses 144
replacing 144

G

Gasoline 25
Gasoline gauge 81
Gearbox, sequential 71
Gearshift lever 70
Glove compartment 101
Grills 96
Gross vehicle weight 152

H

Hands-free system 102
Hardtop 113
Hazard warning flashers 14
Hazard warning triangle 23
Head restraints 50
Headlamp 92

Headlamp cleaning system
122, 124, 153
Headlamp control 92
Headlamp flasher 76, 93
Heated mirror 55
Heated seats 54
Heavy loads 106
High beams 76, 93
indicator lamps 21
Holder for beverages 102
Hood release 120
Horn 14
Hydroplaning 111, 115

I

Ice warning 84
Ignition key 30
positions 66
Ignition lock 66
Imprint 4
Indicator lamps 18
Individual settings, Vehicle
Memory, Key Memory 65
Inflation pressure 25, 115
INSPECTION 82
Instrument cluster 16
Instrument lighting 93
Instrument panel 14, 16
Interface socket for onboard
diagnostics (OBD) 130
Interior lamps 32, 94
remote control 32

Interior motion sensor 38
remote control 32
switching off 32, 39
Interior rearview mirror
automatic dimming
feature 56
Interior temperature
adjusting 98
Intermittent mode 77

J

Jump-starting 145

K

Key Memory 65
Keys 30

L

Lamp replacement 135
Lamps
daytime driving lamps 92
fog lamps 94
footwell lamps 94
headlamp flasher 76, 93
high beams 93
instrument lighting 93
interior lamps 94
low beams 92
parking lamps 92
reading lamps 94
standing lamps 93
Lashing fittings 107

LATCH child-restraint mounting system [62](#)

Leather care, refer to the Caring for your vehicle brochure

Length [151](#)

License plate lamp replacing bulb [139](#)

Light switch [92](#)

Lighter [102](#)

Lighting, see lamps

LIGHTS ON warning [92](#)

Load-securing devices [106](#)

Lock, steering wheel [66](#)

Low beams [92](#)
bulb replacement [135](#)

Luggage compartment [35](#), [37](#)

capacity [152](#)
floor panel [37](#)
increase volume [37](#)

Luggage compartment lid [35](#)

emergency release [36](#)
manual operation [35](#)
opening from the inside [35](#)
remote control [32](#)
securing separately [35](#)

Luggage compartment lighting [35](#)

Luggage rack [107](#)

Lumbar support [50](#)

M

M Engine dynamics control [91](#)

M Mobility system [139](#)

M+S tires [118](#)

Maintenance [82](#), [128](#)

Malfunction displays [82](#)

Manual operation convertible top [44](#)

Manual transmission [70](#)

Master keys [30](#)
with remote control [30](#)

Memory [53](#), [65](#)

Microfilter [100](#)

Microphone [102](#)

Mirror defrosting [55](#)

Mirror memory [53](#)

Mirrors [55](#)
automatic curb monitor [54](#)
inside rearview [56](#)
outside [55](#)

Mobility system [139](#)

Modifications, technical [5](#)

Mounting the roof rack [113](#)

Multifunction switch [76](#)

N

Navigation system, refer to Owner's Manual for Onboard Computer

Neckrest [50](#)

O

OBD interface socket [130](#)

Odometer [80](#)

Oil

additives [125](#)

capacity [153](#)

quality [125](#)

viscosity [125](#)

Oil change interval, see Service and Warranty Information Booklet for US models / Warranty and Service Guide Booklet for Canadian models

Oil filter change [153](#)

Oil level

checking [124](#)
indicator lamp [19](#)
warning lamp [18](#)

Oil pressure warning lamp [18](#)

OIL SERVICE [82](#)

Oil types [125](#)

Onboard computer, refer to the Owner's Manual for Onboard Computer

Onboard tool kit [134](#)

Opening and closing from inside [34](#)
via remote control [31](#)
via the door lock [33](#)
Operating elements [14](#)

Outlets, ventilation [96](#)

Outside temperature display [84](#)

P

Paintwork care, refer to the Caring for your vehicle brochure

Panic mode, trigger alarm [32](#)

Park Distance Control (PDC) [86](#)

Parking aid [86](#)

Parking brake [69](#)

Parking lamps [92](#)

PDC Park Distance Control [86](#)

Pollen [100](#)

Power output [150](#)

Power seat [49](#)

Pressure, tires [25](#), [115](#)

R

Radiator [153](#)

Radio navigation, refer to Owner's Manual for Radio [85](#)

Radio, refer to the Owner's Manual for Radio

Rain sensor [77](#)

Range [85](#)

Everything from A to Z

Reading lamps
 front 94
 rear 95

Rear lamps 137

Rear window defroster 99

Rear-entry assist 51

Rearview mirror 55

Recirculated-air mode 99

Refueling 24

Remote control 31

Remote key 30

Replacement key 30, 31

Reporting safety defects 6

Reserve indicator lamp 81

Restraint system 59

Reverse 70

Rims 118

Rollover protection
 system 63
 indicator lamp 19
 lowering 63

Roof load capacity 152

Roof-mounted luggage
 rack 107

S

Safe seating position 48

Safety belts 52
 seat-integrated belt system (SGS) 51

Seat
 rear-entry assist 51

Seat adjustment 48, 49
 lumbar support 49, 50
 power seats 49

Seat heating 54

Seat memory 53

Securing cargo 106

Securing child-restraint system 61

Securing devices 107

Sequential M gearbox
 SMG II 71
 indicator lamp 19, 75

Service and Warranty Information Booklet 128

SERVICE ENGINE SOON
 warning lamp 19

Service interval display
 82, 128

Set clock 83

Side airbags 57

Side turn signals
 bulb replacement 136

Size 151

Ski bag 104

SMG gearbox 71

Snow chains 119

Socket 103

Spare key 30

Speedometer 16

Sport mode 91

Standing lamps 93
 bulb replacement 135

Starting problems 67

Starting the engine 67

Steering wheel lock 66

Steering wheel with multi-function buttons 22

Steering wheel, adjusting 55

Storage compartments 101

Stroke 150

Summer tires 118

Surface ice warning 84

Switching off the engine 69

Symbols used 4

T

Tachometer 16, 80

Tail lamp assembly
 replacing bulb 137

Tail lamps 137
 replacing bulb 137

Tank capacity 153

Technical data 150

Technical modifications 5

Telephone hookup 102

Telephone, refer to the separate Owner's Manual

Temperature adjustment 98

Temperature display
 engine coolant 81
 ice warning 84
 interior temperature 98
 outside temperature 84

Temperature gauge 80

Temperature layering 99

Thigh support area, adjusting 49

Third brake lamp 138

Tilt alarm
 deactivate 32, 39

Tilt alarm sensor
 remote control 32

Time 83

Tire code 118

Tire damage 115

Tire inflation pressure
 25, 115
 checking 25

Tire pressure monitor (TPM) 88

Tire replacement 116

Tire tread 115

Tools 134

Torque 150

Towing eyelet 146

Towing the vehicle 146

Track 151

Transmission 70

Transporting children safely 59

Tread depth, tires 115

Tread wear indicator 115

Trip odometer 80

Trunk, see Luggage compartment 35, 152

Everything from A to Z

Trunk lid, see Luggage compartment lid [35](#)

Turn signal indicator [76](#)
 indicator lamps [20](#)
 replacing bulb [136](#)

Turning circle [151](#)

U

Uniform Tire Quality Grading [117](#)

Upholstery care, refer to the Caring for your vehicle brochure

Used batteries [143](#)

V

Vacuum cleaner, connecting [103](#)

Variable pre-warning zone [80](#)

Vehicle

break-in procedures [110](#)
 starting [67](#)

switching off [69](#)

Vehicle battery [143](#)

Vehicle Memory [65](#)

Vehicle weight [152](#)

Ventilation [96](#)
 draft-free [99](#)

Viscosity [125](#)

W

Warning lamp Please fasten safety belts [18](#)

Warning lamps [18](#)

Warning messages [82](#)

Warranty and Service Guide Booklet [128](#)

Warranty, refer also to separate booklet [6](#)

Washer fluid
 adding [124](#), [153](#)
 indicator lamp [19](#)

Washer/wiper system [77](#)

Washing vehicle, refer to the Caring for your vehicle brochure

Water on roadways
 deep water [111](#)

Wear indicator for tires [115](#)

Weights [152](#)

Wheelbase [151](#)

Wheels and tires [118](#)

Wheelslip control, see DSC [87](#)

Width [151](#)

Wind deflector [46](#)

Window condensation,
 removing [98](#)

Windows

convenience operation [33](#)
 defrosting [98](#)

Windshield washer reservoir
 filling [124](#), [153](#)

Windshield wiper blades,
 replacing [134](#)

Windshield wipers [77](#)

Winter tires [118](#)

Wiper blades, replacing [134](#)

Work in the engine compartment [120](#)

X

Xenon lamps [135](#)

Refueling

To ensure that you always have convenient access to all essential information when you stop for fuel, we recommend that you take the time to fill out the adjoining chart by entering the data that apply to your vehicle. Consult the index for individual specifications.

Fuel

Designation	
-------------	--

Please enter your preferred fuel here.

Engine oil

Quality	
---------	--

The oil quantity between the two marks on the dipstick is approx.
1.4 US quarts/1.3 liters.

Tire inflation pressure

	Summer tires		Winter tires	
	front	rear	front	rear
Up to 2 persons				
4 persons plus luggage				

More about BMW

bmwusa.com



The Ultimate
Driving Machine