

2008 Audi R8

Owner's Manual

Introduction

Thank you for choosing an Audi R8 - we value your trust in us.



Your new Audi R8 incorporates the newest technology as well as numerous features designed for your comfort, convenience and safety. We recommend you read your Owner's Manual thoroughly so that you can quickly become acquainted with your Audi.

In addition to explaining how the different features work, we also give you many useful tips and information concerning your safety and that of your passengers, how to care for your vehicle and maintain your vehicle's value.

We hope you enjoy driving your Audi R8 and we wish you safe and pleasant motoring.

AUDI AG

Table of contents

Vehicle literature	5	Front lid	49	Kick-down	90
About this Owner's Manual	6	Anti-theft alarm system	50	Launch Control Program	90
		Power windows	51	Steering wheel with shift paddles	91
Controls and equipment	9	Clear vision	53	Emergency program	91
Cockpit	11	Lights	53	Parking system	93
General illustration	11	Interior lights	58	General information	93
Instruments and warning/indicator lights	12	Vision	59	Acoustic park assist	93
Instruments	12	Wiper and washer system	59	Advanced parking system	94
Warning/indicator lights	16	Mirrors	63	HomeLink®	100
Driver information system	22	Digital compass	65	Universal remote control	100
Introduction	22	Seats and storage	67		
Service interval display	23	General recommendations	67		
On-Board Diagnostic system (OBD)	24	Power seats	68	Safety first	105
Trip computer	25	Head restraints	70	Driving Safely	106
Menu display	26	Cup holder	70	General notes	106
Lap Timer	29	Ashtray	71	Proper occupant seating positions	108
Speed warning system	33	Cigarette lighter/socket	71	Driver and passenger side footwell	112
Warnings and symbols	35	Storage	72	Stowing luggage	113
Opening and closing	42	Warm and cold	74	Reporting Safety Defects	114
Keys	42	Climate controls	74	Safety belts	116
Power locking system	44	Rear window defogger 	78	General notes	116
		Heated seats	79	Why safety belts?	117
		On the road	80	Illustrating the principle of an accident	119
		Steering	80	How are safety belts worn correctly?	120
		Ignition lock and ignition switch	81	Safety belt pretensioners	123
		Starting the engine	81		
		Stopping the engine	82		
		Parking brake	83		
		Cruise control	84		
		Audi magnetic ride	86		
		Automated manual transmission	88		
		Description	88		
		Manual operation	89		
		Automatic operation	90		

Airbag system	125
Important things to know	125
Front airbags	129
Monitoring the Advanced Airbag System	136
Knee airbags	141
Side airbags	144
Child Safety	147
Important things to know	147
Important safety instructions for using child safety seats	150
Child safety seats	152
Installing a child safety seat	156
Tether for children	159
Additional Information	161
	
Vehicle operation	163
Intelligent technology	164
Notice about data recorded by vehicle control modules	164
Electronic Stabilization Program (ESP)	164
Rear spoiler	166
Braking	167
Power steering	168
Driving with your quattro®	169
Dry sump lubrication	169
Driving and environment	170
Break-in period	170
Catalytic converter	170
Sporty driving	170

Operation and maintenance	171
Trailer towing	172



Vehicle care	175
Cleaning and protection	176
General information	176
Care of exterior	176
Care of interior	180
Fuel supply and filling your fuel tank	186
Gasoline	186
Fuel tank	187
Checking and filling	191
Engine compartment lid	191
Engine oil	193
Engine cooling system	197
Brake fluid	200
Battery	200
Windshield washer container	204
Tires and wheels	205
Tires	205
Tire pressure monitoring system	223
Consumer Information	225
Warranty coverages	225
Reporting safety defects	225
Operating your vehicle outside the U.S.A. or Canada	225
Audi Service Repair Manuals and Literature	225
Maintenance	226

Additional accessories, modifications and parts replacement	227
Declaration of Compliance, Telecommunication or Electronic Systems	228



Do-it-yourself service ...	231
What do I do now?	232
Trunk escape handle	232
Breakdown kit	232
Tire repair	233
What should I be aware of when changing a tire?	237
Jump-starting	241
Emergency towing with commercial tow truck	243
Fuses and bulbs	245
Fuses	245
Bulbs	248



Technical data	251
General information	252
Explanation of technical data	252
Vehicle identification	252
Weights	253
Data	254
R8 4.2 quattro	254
Dimensions	254
Capacities (approx.)	254



Alphabetical index	257
---------------------------------	-----

Vehicle literature

In addition to this Owner's Manual, your Audi comes with a Warranty & Maintenance booklet.

Moreover, depending on the model and the equipment, there may be additional instruction booklets delivered with your vehicle (for example, Operating Instructions for your Sound System, Navigation System etc.).

If you are missing one of these publications, or if you believe that the information is not complete, contact your authorized Audi dealer for assistance.

The Warranty & Maintenance booklet

explains how you can keep your Audi in top driving condition by having it serviced regularly and contains detailed information about the warranties covering your Audi. Always have the booklet with you when you take your vehicle to an authorized Audi dealer for service. Your Audi Service Adviser will record each scheduled service and can answer any questions you may have regarding how to maintain your vehicle.

In Canada,

the vehicle literature is also available in French. To obtain a copy, contact your dealer or write to:

Au Canada, on peut se procurer un exemplaire en français de ce document auprès du concessionnaire ou de:

Volkswagen Canada, Inc.
Client Assistance
Assistance à la Clientèle
777 Bayly Street, West,
Ajax, Ontario L1S 7G7

If you sell your Audi

all literature should be left in the vehicle to make the Warranty terms as well as all operating, safety and maintenance information available to the next owner.

If you change your address or if you bought this Audi used

be sure to send in a "Notice of Address Change" / "Notice of Used Car Purchase" post card. This card can be found in the Warranty & Maintenance booklet or obtained from your authorized Audi dealer.

It is in your own interest that we are able to contact you should the need arise. ■

About this Owner's Manual

This owner's manual contains important information, tips, suggestions, and warnings for the use of your vehicle.

Make sure that this owner's manual is always located in the vehicle. This is especially important if you allow other people to drive the vehicle, or if you sell it.

This owner's manual describes the **equipment range** specified for this model at the editorial deadline date. Some of the equipment described here will only be available at a later date, or only in specific markets.

Some sections in this owner's manual do not apply to all vehicles. In that case, the **range of applicability** is given at the beginning of the section, e. g. "Applies to vehicles: with R tronic". In addition, optional equipment is indicated by an asterisk "*".

The details in the **illustrations** may be different from those in your vehicle, and are intended to be viewed as a basic guide.

Please note that the **pictures** in this manual show the European Audi R8 model. It may show features not available in North America.

You will find a **table of contents** at the beginning of this book, which displays all topics described in this manual in order of appearance. You will find an alphabetical **index** at the end of this book.

All **directions**, such as "left", "right", "front", "back", are relative to the direction of travel.

* optional equipment

► This section continues on the next page.

■ Indicates the **end of a section**.

® Registered trademarks are identified with a ®. If this symbol is missing, it is no guarantee that the terms can be used freely.

⇒ ⚠ Cross-reference to a "WARNING!" within a section. For indication with a page number, the corresponding "WARNING!" can be found outside of the section.



WARNING

Text with this symbol contains important information on safety and how to reduce the risk of personal injury or death.



Note

Text with this symbol draws your attention to potential sources of damage to your vehicle.



For the sake of the environment

Text with this symbol contains information about the environment and how you can help protect it.



Tips

Text with this symbol contains special tips and other information about getting the most out of your vehicle and its features. ■





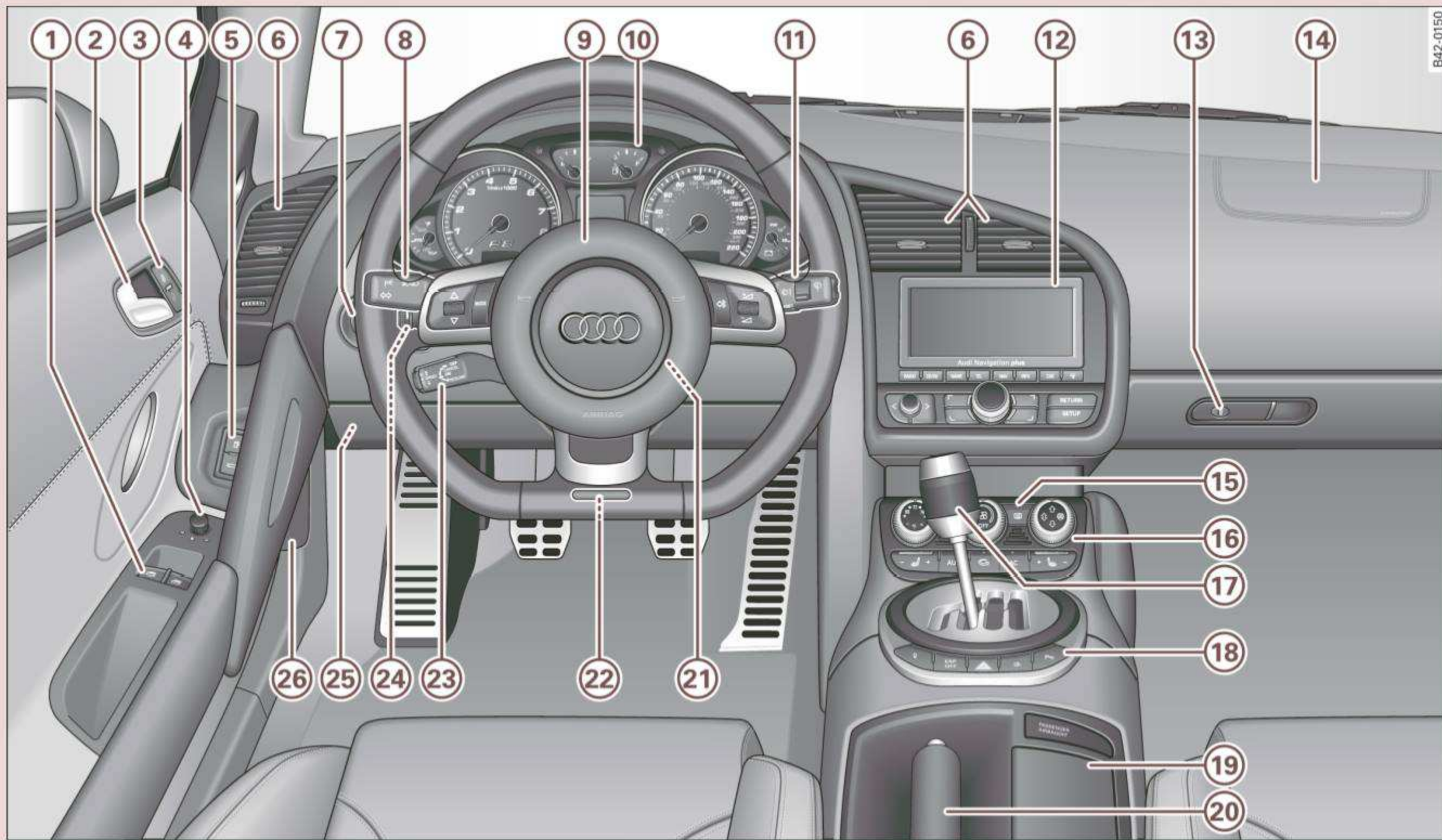

Fig. 1 Some of the equipment or features shown in the general illustration may be standard equipment on your vehicle or may be optional equipment depending on your model.

Cockpit

General illustration

① Power window switches	51	⑩ Instrument cluster	12
② Door handle		⑪ Switches for:	
③ Power locking switch	47	– Windshield wiper/washer	59
④ Adjuster control for outside mirrors	64	– Trip computer	25
⑤ Switches for:		– Menu display	26
– Front lid release	49	– Lap Timer	29
– Fuel filler flap release	188	– Speed warning system	33
⑥ Air outlets	76	⑫ Navigation system	
⑦ Light switch	53	⑬ Glove compartment (lockable)	72
⑧ Turn signal and high beam	57	⑭ Front passenger's airbag	129
⑨ Multifunction steering wheel with:		⑮ Rear window defogger switch	78
– Horn			
– Driver's airbag	129	⑯ Climate controls	74
– Audio, telephone and voice control system operating buttons		⑰ Gear shift lever or selector lever (R tronic):	
– Shift buttons for manual operation (R tronic)	91	– Manual transmission	
		– R tronic	88
		⑱ Switches for:	
		– Audi magnetic ride	86
		– Electronic Stabilization Program (ESP)	164
		– Emergency flasher	57
		– Retractable rear spoiler	166
		– Audi parking system	93
		⑲ Ashtray with cigarette lighter/socket	
		⑳ Parking brake lever	83
		㉑ Steering lock/ignition/starter switch (in the steering wheel column)	81
		㉒ Adjustable steering column	80
		㉓ Cruise control	84
		㉔ Instrument lighting	56
		㉕ Data Link Connector (DLC) for On Board Diagnostics (OBD II)	24
		㉖ Engine compartment lid release	191



Tips

A separate brochure is provided for your factory-installed Audi Navigation System. ■

Instruments and warning/indicator lights

Instruments

Instrument cluster and controls

The instrument cluster is your central source of information.

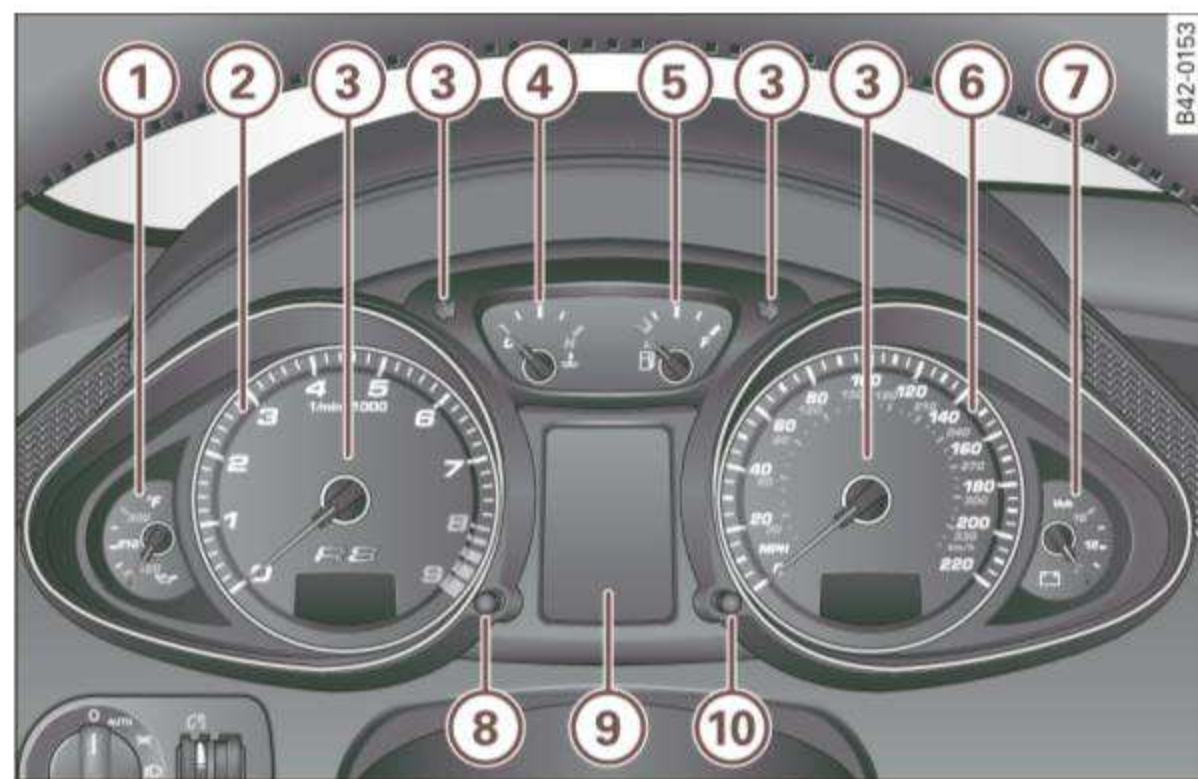

Fig. 2 Overview of the instrument cluster

① Engine oil temperature	12
② Tachometer with time and date display	13, 13
③ Warning/indicator lights	16
④ Coolant temperature gauge	13
⑤ Fuel gauge	14
⑥ Speedometer with odometer	15
⑦ Voltmeter	15
⑧ Set/Check button	13, 36

⑨ Driver information display	22
⑩ Reset button for trip odometer	15

The illumination for the instrument cluster lights up whenever you switch on the ignition with the **vehicle headlights off**. The gauges are also illuminated when the lights are turned on. ■

Engine oil temperature display

The engine oil temperature display ⇒ fig. 2 only operates with the ignition on. To prevent engine damage, please observe the following important points concerning the temperature ranges.

Cold range

If the needle is at the bottom of the gauge, the engine oil has not reached operating temperature yet. Avoid high engine speeds, full throttle applications and heavy engine loads.

Normal range

The engine has reached operating temperature when the needle moves into the center of the gauge under normal driving conditions. The needle may move higher on the gauge with heavier engine load at high outside temperatures. This is not a cause for concern as long as the warning light  in the display does not flash.

Warning light

If the symbol  in the display flashes, either the engine oil temperature is too high or the engine oil level is too low ⇒ page 195.

If the needle is well in the upper area of the gauge, the engine oil temperature is too high. **Stop the vehicle, switch the engine off and allow it to cool.** If the warning light comes on again after driving a short distance, contact an authorized Audi dealer. ■

Tachometer (engine rev counter)

The tachometer indicates the engine RPM (revolutions per minutes).

If engine RPM drops below 1,500, you should downshift to the next lower gear. The red area at the end of the scale indicates maximum permissible engine RPM after the break-in period. Before reaching this area, shift into the next higher gear, switch off the R tronic Sport mode or ease your foot off the accelerator pedal.

! Note

The tachometer needle \Rightarrow page 12, fig. 2 (2) should not move into the red range. If it does, then only for a very short period of time. You could damage your engine by driving at high RPM. ■

Digital clock with date display

Your vehicle is equipped with a quartz controlled digital clock.



Fig. 3 Instrument cluster with the digital clock

Date and time are set using the knob \Rightarrow fig. 3.

To set the hour

- Pull the knob (hour display flashes) and turn it to the left or right.

To set the minutes

- Pull the knob as many times as necessary until the minute display flashes.
- Turn the knob to the left or right.

To set the date

- Pull the knob as many times as necessary until the day, month or year display flashes.
- Turn the knob to the left or right.

To hide or display the date

- Pull the knob as many times as necessary until the date display flashes.
- Turn the knob to the left or right.

When the date display stops blinking, this means the time and date have been successfully stored.

With the ignition off, pushing or pulling the Set/Check button \Rightarrow page 12, fig. 2 (8) can turn on the display field lighting for a few seconds. ■

Engine coolant temperature gauge

The engine coolant gauge \Rightarrow page 12, fig. 2 (4) only works when the ignition is on. To prevent damage to your engine, please note the following important points. ►

Engine cold

As long as the needle remains at the left end of the gauge, the engine still has not reached its operating temperature. Avoid high engine speeds, heavy engine loads and heavy throttle.

Normal temperature

When the engine has reached its operating temperature, the needle will move into the middle of the gauge and remain there. If the engine is working hard at high outside temperatures, the needle may turn further to the right. This is no cause for concern as long as the  warning light in the instrument cluster does not illuminate.

Warning light

When the  warning light starts to flash, this can mean one of two things: either the coolant *temperature* is too high, or the coolant *level* is too low ⇒ *page 37*.

If the needle is well on the right side of the gauge, the coolant temperature is too high. **Stop the vehicle, switch the engine off and allow it to cool.** If the warning light comes on again after driving a short distance, contact an authorized Audi dealer.

WARNING

- Always observe the warning in ⇒ *page 191*, “Working in the engine compartment” before opening the engine compartment lid and checking the engine coolant level.
- Never open the engine compartment lid if you see or hear steam, or if you see engine coolant dripping from the engine compartment. You could burn yourself. Let the engine cool off first so that you cannot hear or see any steam or engine coolant.

Note

- Mounting additional lights or accessories in front of the air inlets reduces the cooling effect of the radiator. At high outside temperatures or high engine load, the engine could overheat.

- The front spoiler has been designed to properly distribute the cooling air when the vehicle is moving. If the spoiler is damaged, this could reduce the cooling effect and the engine could then overheat. Ask your authorized Audi dealer for assistance. ■

Fuel gauge

The fuel gauge works only when the ignition is on. When the needle reaches the red area, the warning light in the instrument cluster will illuminate ⇒ *page 38* . This means you have approximately 2.6 gallons (10 liters) of fuel left in the tank. **Time to refuel!**

The total tank capacity of your vehicle is listed in **Technical data** ⇒ *page 254*.

Note

Never run the tank completely dry! An irregular supply of fuel can cause engine misfiring and fuel could enter into the exhaust system. The catalytic converter could then overheat and be damaged. ■

Speedometer with odometer

The speedometer shows you the vehicle speed, and the odometer shows you how many miles (kilometers) you have driven.



Fig. 4 Speedometer close-up: odometer display

The distance driven is shown in miles (USA models) or in kilometers (Canada models).

Lower odometer

The lower odometer shows the total number of miles (kilometers) driven.

Upper odometer (trip odometer)

The upper odometer shows the total number of miles (kilometers) driven since you last reset the odometer back to zero. You can use this odometer when you want to keep track of how many miles (kilometers) you have driven for a single trip or errand. The last digit indicates 1/10 of a mile (100 meters). You can set the trip odometer back to zero by pressing the reset button ⇒ fig. 4.

With the ignition off, pushing of the Set/Check button ⇒ page 12, fig. 2 ⑧ can turn on the display field lighting for a few seconds.

Malfunction message

If there is a malfunction somewhere in the instrument cluster, **dEF** will appear in the trip odometer and will stay on. Contact your authorized Audi dealer to have the problem corrected.

Immobilizer

When the ignition is switched on, the data on the ignition key are scanned automatically.

If an unauthorized key was used, **SAFE** is displayed continuously in the odometer display field. The vehicle cannot be operated ⇒ page 44. ■

Voltmeter display

The voltmeter shows the voltage in the vehicle electrical system. The normal reading is between 12 and 14 volts. If the reading drops below 12 volts with the engine running, you should have the power supply (battery and generator) inspected by an authorized Audi dealer.



Tips

Voltage can drop below 8 volts when you start the engine. ■

Warning/indicator lights

Overview

The warning/indicator lights indicate different functions or a possible malfunction.

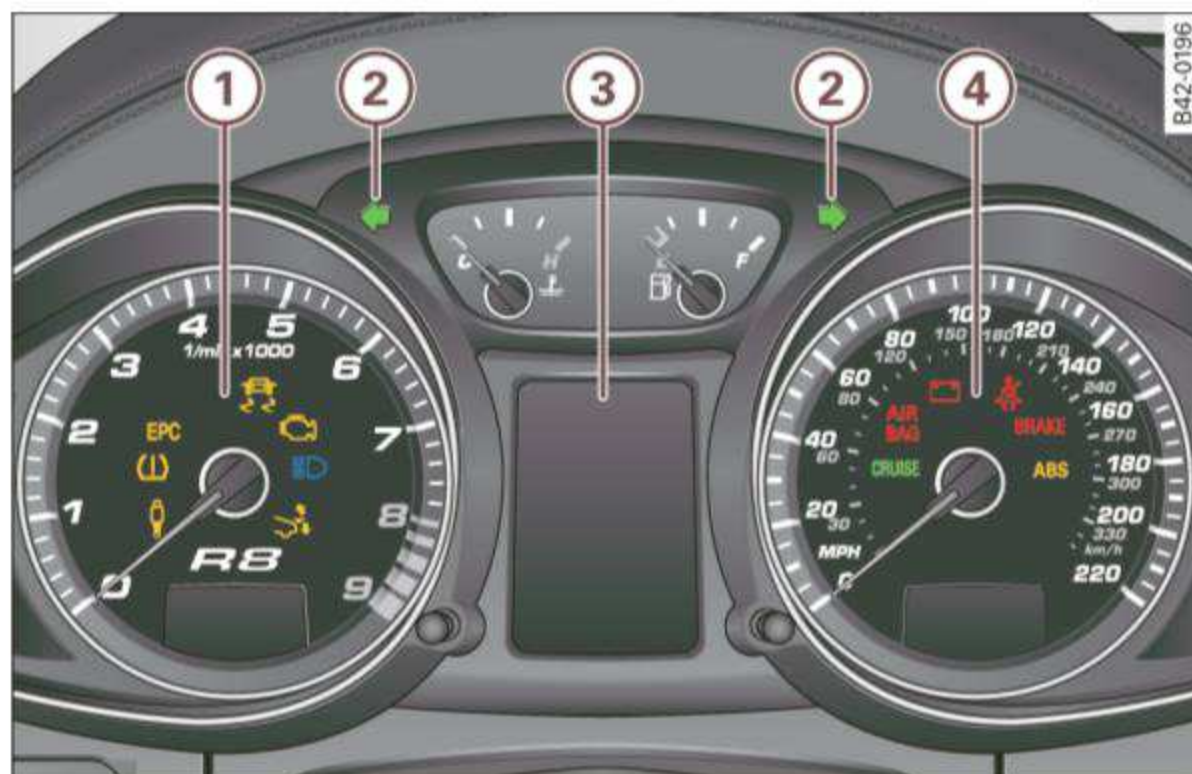



Fig. 5 Instrument cluster with warning/indicator lights

- ① Warning/indicator lights in the tachometer
- ② Turn signals ⇒ page 18
- ③ Warning/indicator lights in the Driver Information System ⇒ page 35
- ④ Warning/indicator lights in the speedometer ■

① Warning/indicator lights in the tachometer

	Audi magnetic ride	⇒ page 17
	Tire pressure too low	⇒ page 17, ⇒ page 224
EPC	Electronic power control	⇒ page 18
	Electronic Stabilization Program (ESP)	⇒ page 18
	USA models: Malfunction Indicator Lamp (MIL)	⇒ page 24
	Canada models: Malfunction Indicator Lamp (MIL)	⇒ page 24
	High beam	⇒ page 18
	Rear spoiler	⇒ page 18

④ Warning/indicator lights in the speedometer

CRUISE	USA models: Cruise control activated	⇒ page 19
	Canada models: Cruise control activated	⇒ page 19
AIR BAG	USA models: Airbag system	⇒ page 19
	Canada models: Airbag system	⇒ page 19

	Generator	⇒ page 19
	Safety belt	⇒ page 19
BRAKE	USA models: Brake system, parking brake set	⇒ page 19
	Canada models: Brake system, parking brake set	⇒ page 19
ABS	USA models: Anti-lock brake system (ABS) defective	⇒ page 20
	Canada models: Anti-lock brake system (ABS) defective	⇒ page 20

WARNING

- Failure to heed warning lights and other important vehicle information may result in serious personal injury or vehicle damage.
- Whenever stalled or stopped for repair, move the vehicle a safe distance off the road, stop the engine, and turn on the emergency flasher ⇒ page 57.
- The engine compartment of any motor vehicle is a potentially hazardous area. Before you check anything in the engine compartment, stop the engine and let it cool down. Always exercise extreme caution when working under the engine compartment lid ⇒ page 191, "Working in the engine compartment"

Tips

- When a yellow warning symbol appears, *one* warning tone sounds. Check the function displayed as soon as possible.

- When a red symbol appears, *three* warning tones sound in a row. The symbol continues to flash until the fault has been corrected. ■

Applies to vehicles: with Audi magnetic ride

Audi magnetic ride

The indicator light monitors vehicle damping.

The indicator light  illuminates when the ignition is switched on as a function check.



Tips

If the indicator lamp illuminates while you are driving, there is a malfunction in the vehicle damping. The chassis should be inspected immediately by an authorized Audi dealer. ■

Applies to vehicles: with tire pressure monitoring system

Tire pressure monitoring system

Tire pressure that is too low must be corrected as soon as possible.

The  warning/indicator light illuminates for a few seconds after the ignition is turned on as a function check. If the  warning light comes on, pressure in at least one tire is too low.

- Stop driving as soon as possible without endangering yourself and other drivers on the road.
- Inspect all tires.
- Correct the tire pressure ⇒ page 211.

Additional information about the **tire pressure monitoring system** can be found ⇒ page 224. ■

Electronic power control

This warning/indicator light monitors the electronic power control.

The  warning/indicator light (Electronic Power Control) illuminates when you switch on the ignition as a function check.

Tips

If this warning/indicator light illuminates while you are driving, then there is a malfunction in the engine electronics. Have the malfunction corrected as soon as possible by your authorized Audi dealer or qualified workshop. ■

Electronic stabilization program (ESP)

The warning/indicator light monitors the electronic stabilization program.

The warning/indicator light  has the following functions:

- It blinks while you are driving, when the ESP is working.
- It illuminates when you switch on the ignition for approximately 2 seconds as a function check.
- It illuminates when there is a malfunction in the ESP.
- It illuminates when the ESP is switched off.
- It illuminates if there is a malfunction in the ABS, since the ESP is part of the ABS system.

If the ESP warning/indicator light illuminates and stays on after you have started the engine, this may mean that the control system has temporarily switched off the ESP. If this is the case, you can reactivate the ESP by switching the ignition off and then on again. The warning/indicator light should go out to show that the system is fully functional again.

For more information about the ESP ⇒ *page 164.*

If the battery is disconnected and reconnected, this warning/indicator light illuminates after the engine starts until you have driven straight ahead for a short distance. ■

High beam

The  warning/indicator light illuminates when the high beams are on or when you use the headlight flasher.

For more information ⇒ *page 57.* ■

Rear spoiler



The warning/indicator light monitors the electrically retractable rear spoiler.

The warning/indicator light  has the following functions:

- It comes on for about 3 seconds as a function check when the ignition is switched on.
- It comes on if there is a malfunction in the electrically retractable rear spoiler.

Additional information about the electrically retractable rear spoiler ⇒ *page 166.* ■

Turn signals

Whenever you use the left  or the right  turn signal, the indicator light blinks. When you use the emergency flasher, both indicator lights flash.

If one of the turn signal light bulbs burn out, the turn signal will blink twice as fast as normal.

Additional information on the turn signals ⇒ *page 57.* ■

Cruise control



CRUISE (USA models) / (Canada models)



The **CRUISE** warning/indicator light illuminates when the cruise control is activated. ■

Airbag system

(USA models) / (Canada models)

This warning/indicator light monitors the airbag and the pretensioner systems.

The  (USA models) /  (Canada models) warning light illuminates for a few seconds each time you switch on the ignition.

If the  (USA models) /  (Canada models) warning light does not go out, or if it illuminates while you are driving, or if it starts to blink, then there is a malfunction somewhere in the system. If the light does not illuminate when you switch on the ignition, this also means there is a malfunction.

WARNING

If you have a malfunction in the airbag system, contact your authorized Audi dealer immediately. Otherwise the airbag or the belt pretensioner may not work properly in an accident. ■

Generator

This warning/indicator light detects a malfunction in the generator or in the vehicle's electrical system.

The  warning/indicator light illuminates when you switch on the ignition and must go out after the engine has started.

If the  warning/indicator light illuminates while you are driving, you should contact your authorized Audi dealer. Since the vehicle

battery is discharging, you should switch off any unnecessary electrical consumers (for example, the air conditioner).

Note

If the  warning/indicator light (malfunction in the engine cooling system) in the instrument cluster should illuminate ⇒ *page 37*, stop the vehicle and turn off the engine. The coolant pump is not working - this can cause engine damage! ■

Safety belt warning light



The warning light is a reminder to fasten safety belts.



The warning light  comes on for a few seconds after the ignition is switched on as a reminder to fasten your safety belt. Additionally, an acoustic warning (gong) will also sound.

Additional information on safety belts ⇒ *page 116*. ■



Brake system **BRAKE (USA) / (Canada)**

This warning/indicator light flashes when the brake fluid level is too low or when there is a malfunction in the ABS.



If the warning/indicator light flashes **BRAKE / ** (with the parking brake released), stop the vehicle and obtain qualified help ⇒ .

If the ABS fails, the ABS warning/indicator light **ABS / ** illuminates along with the brake system warning/indicator light **BRAKE / ** ⇒ .

Parking brake set

The **BRAKE / ** warning/indicator light illuminates when the parking brake is set ⇒ . The following message appears in the display: **Parking brake is applied**. If you inadvertently drive off with the parking brake applied, a buzzer (warning tone) sounds. ►

 **WARNING**

- **USA models:** If both, the **BRAKE** warning light and the **ABS** warning light come on at the same time, the rear wheels could lock up first under hard braking. Lock-up of the rear wheel brakes can cause loss of vehicle control and an accident. Have your vehicle repaired immediately by your authorized Audi dealer or a qualified workshop. Drive slowly and avoid sudden, hard brake application.
- **Canada models:** If both, the brake warning light  and the ABS warning light  come on at the same time, the rear wheels could lock up first under hard braking. Lock-up of the rear wheel brakes can cause loss of vehicle control and an accident. Have your vehicle repaired immediately by your authorized Audi dealer or a qualified workshop. Drive slowly and avoid sudden, hard brake application
- If the brake warning/indicator light does not go out after a few seconds and the parking brake released, or lights up while you are driving, the fluid level in the brake fluid reservoir is too low. If you believe that it is safe to do so, proceed immediately at low speed to the nearest authorized Audi dealer or qualified workshop and have the brake system inspected.
- Please be very careful and always keep in mind that after several brake applications, you will need greater pressure on the brake pedal to stop your vehicle. Consequently, you must allow for increased braking distances. Trying to brake as quickly as usual could lead to an accident. ■

Anti-lock brake system

ABS (USA)/ (Canada)

This warning/indicator light monitors the ABS and the electronic differential lock (EDL).

The **ABS** light will come on for a few seconds when the ignition is switched on. The light will go out after an automatic check sequence is completed.

There is a malfunction in the ABS when:



- The warning/indicator light does not illuminate when you switch on the ignition.
- The warning/indicator light does not go out after a few seconds.
- The warning/indicator light illuminates while driving.

The brake system will still respond even without the assistance of the ABS system. See your authorized Audi dealer as soon as possible to restore full braking performance. For more information regarding the ABS ⇒ *page 164*.

The ABS warning light and the brake warning light come on together. The ABS will not work and you will notice a change in braking response and performance.

Malfunction in the brake system



USA models: If both, the **BRAKE** warning light and the **ABS** warning light come on ⇒ *page 37* when the parking brake is released, there may be a malfunction in the ABS, and there may also be a malfunction in the brake system itself ⇒ .

Canada models: If both, the brake warning light  and the ABS warning light  come on ⇒ *page 37* when the parking brake is released, there may be a malfunction in the ABS, and there may also be a malfunction in the brake system itself ⇒ . ►

Malfunction in the electronic differential lock (EDL)

The two systems EDL and ABS work together. The **ABS** warning light will come on if there is a malfunction in the EDL system ⇒ *page 164*. See your authorized Audi dealer as soon as possible.

WARNING

- If the **ABS** warning light does not go out, or if it comes on while driving, the ABS system is not working properly. The vehicle can then be stopped only with the brakes operating without ABS support. You will not have the protection ABS provides. Contact your authorized Audi dealer as soon as possible.
- *USA models:* If both, the **BRAKE** warning light and the **ABS** warning light come on at the same time, the rear wheels could lock up first under hard braking. Lock-up of the rear wheel brakes can cause loss of vehicle control and an accident. Have your vehicle repaired immediately by your authorized Audi dealer or a qualified workshop. Drive slowly and avoid sudden, hard brake application.
- *Canada models:* If both, the brake warning light  and the ABS warning light  come on at the same time, the rear wheels could lock up first under hard braking. Lock-up of the rear wheel brakes can cause loss of vehicle control and an accident. Have your vehicle repaired immediately by your authorized Audi dealer or a qualified workshop. Drive slowly and avoid sudden, hard brake application. ■

Driver information system

Introduction

The Driver information display inside the instrument cluster provides you, the driver, with important information.



Fig. 6 Instrument cluster: center display

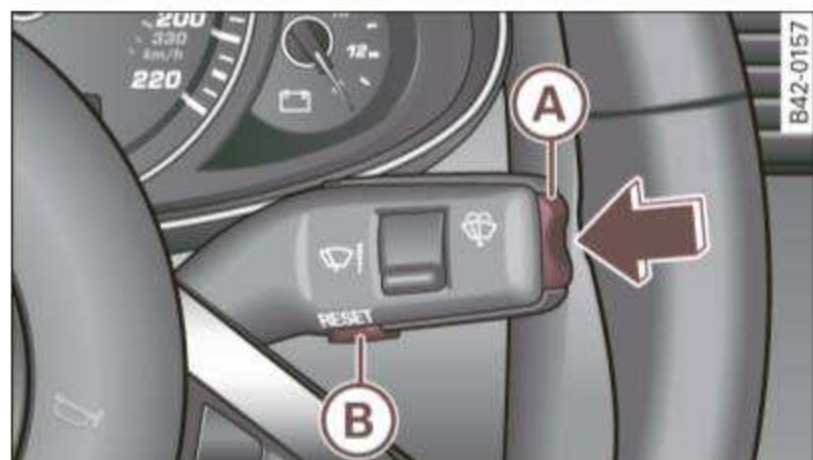

Fig. 7 Wiper lever: controls for the menu display

Center display

With the ignition on, the display in the Driver Information System shows the following information:

- CD* inserted or Radio* station set
- Outside temperature*: At temperatures below 41 °F (+5 °C), a snowflake symbol appears in front of the temperature display ⇒ ⚠.

- Warning: front lid, door or engine compartment lid open: The display appears if the door, the engine compartment lid or front lid is not closed.
- Warning: close fuel tank cap: The Driver information display indicates when the filler cap is not secured or missing ⇒ page 188.

Additional functions

You can open the following functions in the Driver Information System display by pressing the **RESET** button ⇒ fig. 7 one or more times:

Trip computer	⇒ page 25
Digital speedometer*	
Menu display	⇒ page 26
Lap Timer	⇒ page 29

The speed warning system is also displayed in the Driver Information System. You can read how to set it in ⇒ page 33.

Auto Check Control

Some functions and vehicle components are scanned for their operating status when you switch the ignition on and while you are driving. Malfunctions or required service procedures are signaled audibly and indicated by red and yellow illuminated symbols and reminders in the display ⇒ page 35.

⚠ WARNING

- **Never rely exclusively on the outside temperature display to determine if a road surface is icy or not. Keep in mind that road surfaces, especially bridges and overpasses, could be ice covered and slippery even at an outside temperature above 41 °F (+5 °C).**

⚠ WARNING (continued)

- Always remember, even if the “snowflake” symbol (ice warning) does not appear in the display, black ice could be on the road.
- Always reduce your speed and drive with special care in cold weather conditions when the chance of encountering icy road surfaces increases.

i Tips

- On vehicles with R tronic, the reminders do not appear in the display until you select a gear.
- On vehicles with Audi Navigation system*, the displays may differ from their normal appearance during navigation. ■

Service interval display

The service interval display reminds you when your next service is due.

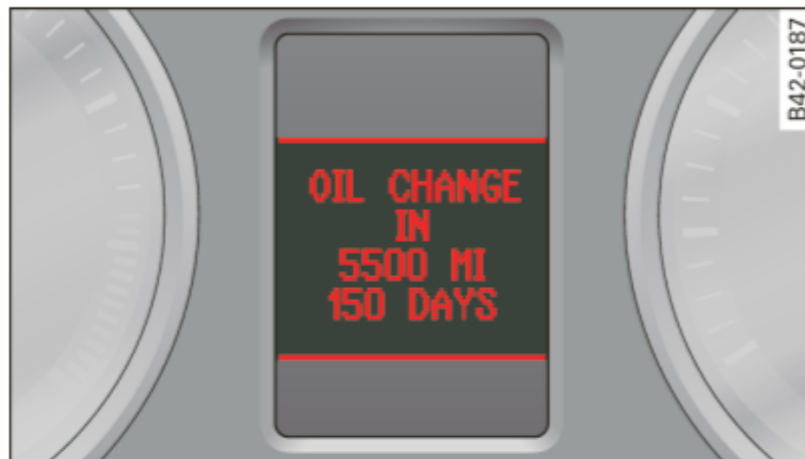

Fig. 8 Section of instrument cluster: Service interval display

The service interval display determines when a service procedure is needed for your vehicle. It operates in two stages:

- Service reminder: Before reaching a service event, this message appears briefly when you switch on the ignition: **OIL CHANGE IN 1230 MI (2000 KM) 150 DAYS**.
- Service event: When the date for service is reached, the message **OIL CHANGE!** appears. It is accompanied by an audible signal.

Display remaining distance

By briefly pulling the knob, **10** ⇒ page 12, fig. 2, the distance/time remaining to the next service date is displayed with the ignition on. The distance/time remaining is updated every 300 miles (500 km).

If the distance/time remaining is called up on new vehicles or after service has been performed, the due date is always shown in the display with **OIL CHANGE IN ----- MI (KM)--- DAYS** within the first 300 miles (500 km).

To reset the display

The dealership performing the service resets the display when the service has been completed. The display is resets as follows:

- Switch the ignition on.
- Pull the knob **10** ⇒ page 12, fig. 2, this message appears: **OIL CHANGE!**
- Pull the knob until the display **OIL CHANGE IN ----- MI (KM) --- DAYS** appears in the display. If the reset button is not pulled within 5 seconds, the display reset mode closes.

i Tips

- If a malfunction is present (red symbol), the distance remaining cannot be called up.
- Do not reset the display between service intervals. Doing so will result in an incorrect display.
- If the battery is disconnected, the Service Interval Display values are retained.
- On vehicles with the Driver Information System, you can also call up the service interval display ⇒ page 26. ▶

- If service was not performed at the correct time or the service interval display was not reset after service was performed, the additional mileage driven or the elapsed days will be shown as negative numbers. ■

On-Board Diagnostic system (OBD)

On-Board Diagnostics

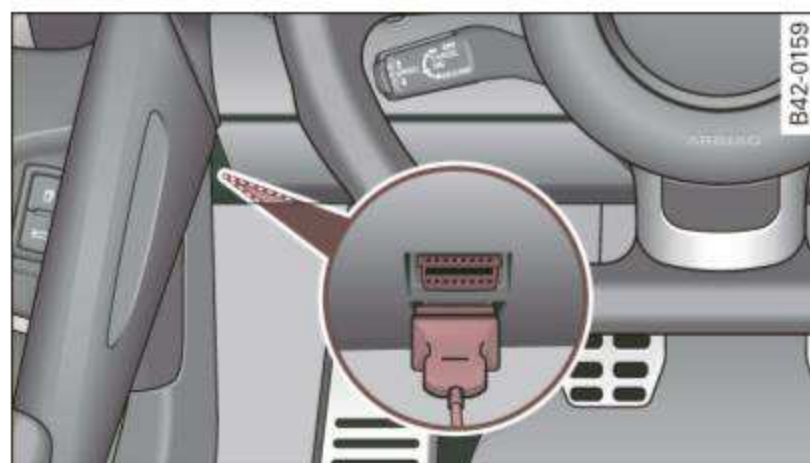

Fig. 9 Location of Data Link Connector (DLC)

On-Board Diagnostics monitors the components of your emission control system. Each monitored component in your engine system has been assigned a code. In case of a malfunction, the component will be identified and the fault stored as a code in the control module memory.

In order to make an accurate diagnosis, the stored data can only be displayed using special diagnostic equipment (generic scan tool for OBD).

In order to connect the special diagnostic equipment, push the plug into the Data Link Connector (DLC). The DLC is located to the right of the engine compartment lid release ⇒ fig. 9.

Your authorized Audi dealer or a qualified service station can interpret the code and perform the necessary repair. ■

Malfunction Indicator Lamp (MIL)

The Malfunction Indicator Lamp (MIL) is part of the On-Board Diagnostic (OBD II) system.

The warning light illuminates when there is a malfunction in the engine electronic system. A malfunction may have various causes:

- The fuel filler cap may be improperly closed ⇒ *page 188*.
- There is a leak in the fuel vapor recovery system.
- The engine control receives faulty vehicle roadspeed signals.

Contact your nearest authorized Audi dealer for assistance.

If the light starts flashing, the catalytic converter could be damaged. Continue driving **with reduced power** (avoiding sustained high speeds and/or rapid accelerations) and have the condition corrected.

An improperly closed fuel filler cap may also cause the MIL light to illuminate ⇒ *page 188*. ■

Trip computer

Introduction

The trip computer gives you information on current and average fuel mileage, average speed, fuel range and driving time.



Fig. 10 Trip computer 1

You can switch between the trip computer 1 and 2 by pressing the **Reset** button **(B)** ⇒ page 26, fig. 11.

You can tell which memory level is currently active by the number in the display ⇒ fig. 10. The data from the single-trip memory (memory level 1) is being displayed if a **1** appears in the display. If a **2** is shown, then the data from the total-trip memory is being displayed (memory level 2).

Single-trip memory (Trip computer 1)

The single-trip memory stores the trip information from the time the ignition is turned on until it is turned off. If the trip is continued **within 2 hours** from the time the ignition was turned off, the new data will be included in the calculation of the current trip information. If the trip is interrupted for **more than 2 hours** the memory is reset automatically.

Total-trip memory (Trip computer 2)

Unlike the single-trip memory, the total-trip memory is not reset automatically. This permits you to evaluate your driving data for the entire period between manual resets.

Fuel range

The estimated cruising range in miles (km) appears in the display. The display changes in increments of 6 miles (10 km).

Average fuel mileage

The average fuel economy in MPG (l/100 km) since you last cleared the memory appears in this display.

Current fuel mileage

The instantaneous fuel consumption in miles per gallon (l/100 km) is shown in this display. When the vehicle is stationary, the most recent fuel consumption is displayed.

Average speed

The average speed in mph (km/h) since the last time the display was reset appears in the display.

Elapsed time

The length of time that you have been driving since you last reset the memory appears in this display. The maximum time period that can be recorded is 999 hours and 59 minutes.

Distance

The elapsed distance since the last time the memory was cleared appears in the display. The maximum distance that can be recorded is 9,999.9 miles (9,999.9 kilometers).



Tips

All stored values will be lost if the vehicle battery is disconnected. ■

Operation

The trip computer is controlled by two switches on the windshield wiper lever.

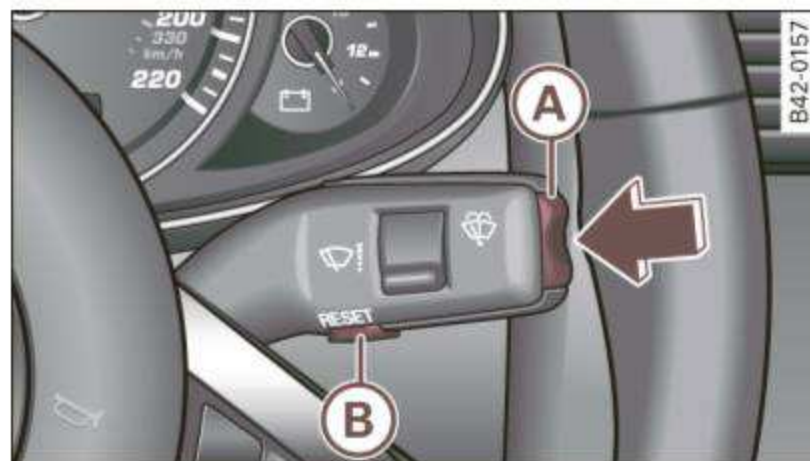

Fig. 11 Wiper arm/wiper lever: controls for the trip computer

Selecting the trip computer

- Tap the **Reset** button **(B)** until the trip computer (memory level 1 or 2) appears in the display ⇒ *page 25*, fig. 10.

Selecting the functions

- Push in the upper (lower) protrusion on the function selector switch **(A)** ⇒ fig. 11. The functions for the trip computer are displayed in succession on the respective memory levels.

Resetting the function to zero

- Push the **Reset** button **(B)** for at least two seconds.

You can reset the following values to zero using the **Reset** button:

- driving time
- distance
- average fuel mileage
- average speed

The trip computer only operates when the ignition is on. When you turn on the ignition, the function that was in use when you last turned the ignition off will be displayed.

Tips

- You can also set the values for the functions to zero in the menu display (**Reset**) ⇒ *page 26*.
- All stored values will be lost if the vehicle battery is disconnected. ■

Menu display

Introduction



Fig. 12 Wiper lever: Controls for the menu display

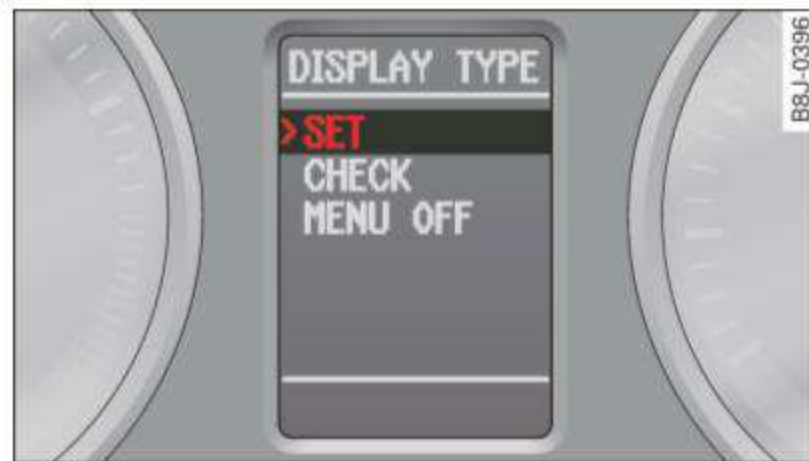

Fig. 13 Display: Start menu

Some functions in your vehicle can be set, activated, and controlled by **Menus** (e.g. Acoustic park assist*). With these menus you can also select the information shown in the driver information system, which operates only with the ignition switched on. Operation is controlled by the **Reset** button and the rocker switch on the wiper lever ⇒ *page 26*, fig. 12.

The **Start menu** shows you the different display types:

Set

Check

Menu off

Each display type in the Start menu contains a submenu with additional options.

Set	Clock	⇒ <i>page 29</i>
	Computer	⇒ <i>page 29</i>
	Speed warning	⇒ <i>page 34</i>
	Language	⇒ <i>page 29</i>
	Units (distance, fuel consumption, temperature)	⇒ <i>page 29</i>
	Lights	⇒ <i>page 53</i> ⇒ <i>page 55</i>
	Wipers (service position)	⇒ <i>page 61</i>
	Doors (Auto-lock)	⇒ <i>page 45</i>
	Parking aid*	⇒ <i>page 93</i>
Check	Service	
	Chassis number	⇒ <i>page 252</i>
	Keys	
Menu off	The menu display is hidden and the lap timer appears.	

Navigating the menu

Use the rocker switch on the windshield wiper lever and the **Reset** button to operate the menu and carry out inquiries and selections.

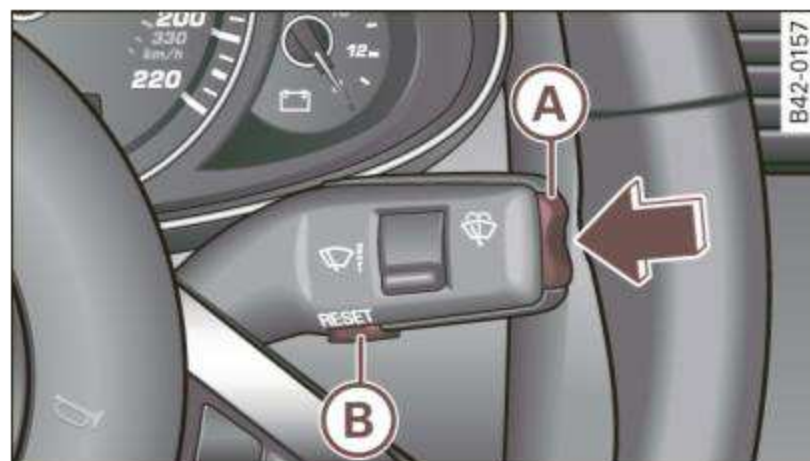

Fig. 14 Wiper lever: Controls for the menu display

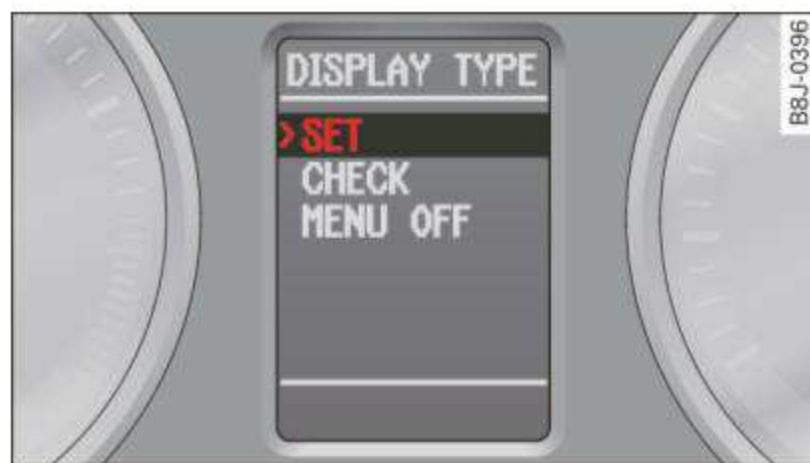

Fig. 15 Display: Start menu

Reset button (B) and **rocker switch** (A) ⇒ fig. 14 functions:

To open the menu

- Press the **Reset** button (B) until the menu display ⇒ fig. 15 appears.

Selections and settings

- Press the rocker switch (A) to reach a menu display. The switch is operated the same as the display (up/down).

Entering and confirming

- Press the **Reset** button (B).

Returning to the Start menu

- Press the **Reset** button longer than 2 seconds to return from any menu level to the Start menu.

Using the rocker switch, you can select the menus in the display or change settings. A cursor appears on the left in front of the selected values.

By pressing the **Reset** button, you activate the selection you made or confirm the values you set. **Selected** functions are identified with a check mark or are carried out directly.

Meanings of the symbols in the display:

Selection bar	Selected function	Meaning
>	Cursor	Current Selection
✓	Check mark	Selected or Function active
□	Box	Not selected
▲	Triangle pointing up	Previous page
▼	Triangle pointing down	Next page

Selecting settings

The Driver information System settings are menu-guided.

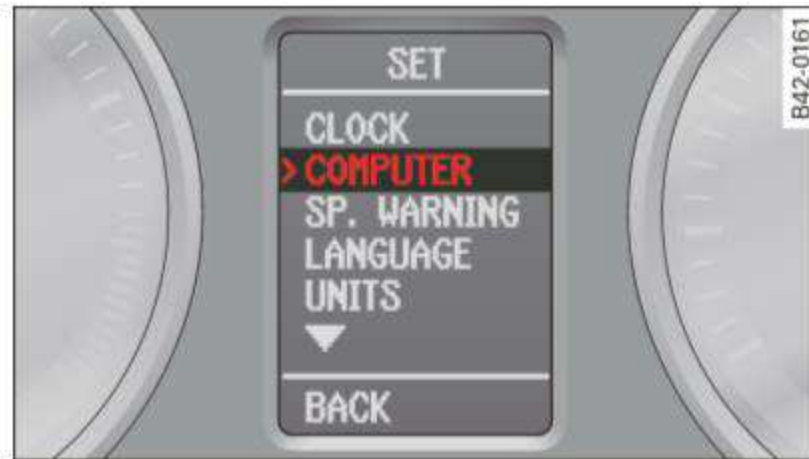

Fig. 16 Display: Menu Settings, computer selected (page 1)

- Press the **Reset** button. The Start menu appears ⇒ page 27, fig. 13.
- Press the rocker switch until **Set** is displayed.
- Press the **Reset** button. All the menus appear.
- Press the rocker switch until the desired line is highlighted (cursor) ⇒ fig. 16.
- Press the **Reset** button.
- If necessary, scroll by selecting and activating the symbol for “Next page” or “Previous page”.

When you have selected the Computer menu and activated it by pressing the **Reset** button, two computer levels appear (computer 1 and computer 2). Now you have to select the level you want using the rocker switch and activate it with the **Reset** button. ■

Lap Timer

Introduction

The lap timer allows you to record and evaluate lap times.

The instrument cluster display shows the time in minutes, seconds and tenths of a second. For lap times longer than one hour, the hour is also shown automatically. The maximum recordable time for a single measurement is 99 hours, 59 minutes and 59 and 9/10 seconds. If the lap timer reaches this value, the timing stops on its own or it switches to pause mode via ⇒ page 31.

WARNING

Please devote your full attention to driving. As the driver, you have complete responsibility for safety in traffic. Only use the functions in such a way that you always maintain complete control over your vehicle in all traffic situations.

Tips

All of the trip computer functions are available as usual when the lap timer stopwatch is running. ■

Selecting the lap timer



Fig. 17 Controls



Fig. 18 Display: Lap timer

- With the ignition on, press the **RESET** button **(B)** ⇒ fig. 17 until the lap timer ⇒ fig. 18 appears. ■

Starting the timer

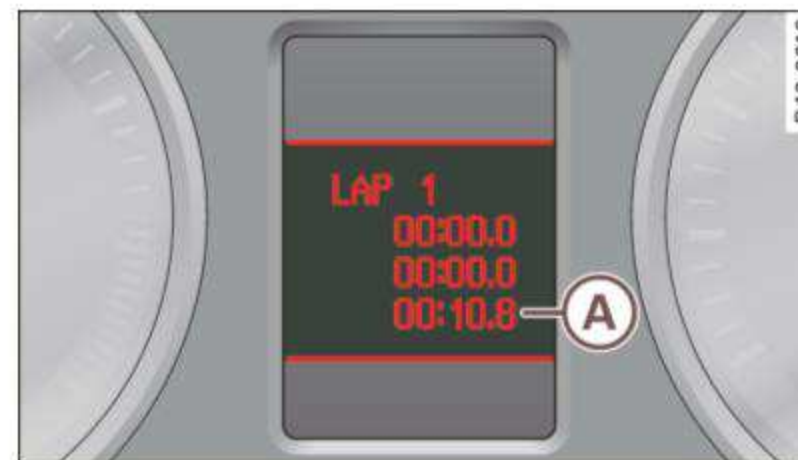

Fig. 19 Display: Lap 1

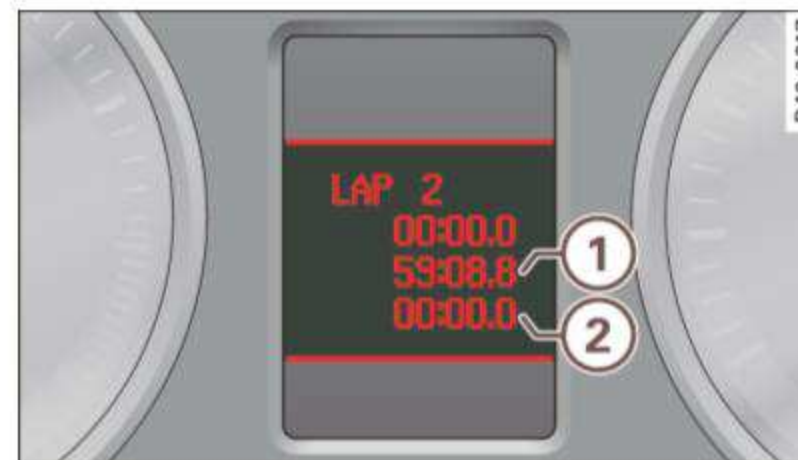

Fig. 20 Display: Lap 1 is saved, lap 2 is started

The top row shows the current lap number: e. g. **LAP 2** (= second lap).

Starting lap time

- Press the upper section of the rocker switch. Row **(A)** ⇒ fig. 19 displays the current lap time.

Saving lap time

- Press the upper section of the rocker switch again. This simultaneously starts the measurement for the next lap. ►

After being saved, the first recorded lap time moves from the lowest to the next highest line in the display ① ⇒ page 30, fig. 20. The lower line ② identifies the newly started lap time. ■

Recording additional lap times

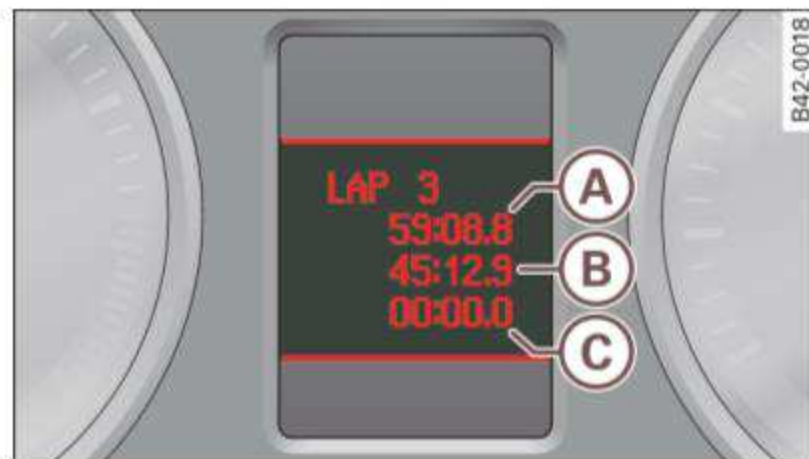

Fig. 21 Display: Lap 2 is saved

After starting the lap timer, a timed lap is completed and stored and timing begins for the next lap every time the upper section of the rocker switch is pressed. Continue as described above to measure additional lap times.

The current lap time is displayed in the bottom line of the display ③ ⇒ fig. 21.

After being saved, the last recorded lap time moves from the lower to the next higher line on the display ② ⇒ fig. 21. The lap time before the last one also moves up one line ①. The lowest line ③ identifies the newly started lap time. ■

Displaying split time or inserting a pause

Split time is indicated by a star.

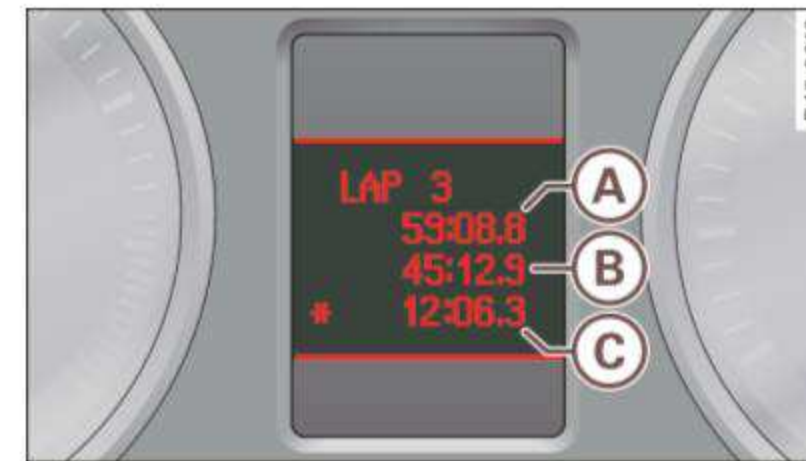

Fig. 22 Display: Showing a split time

It is possible to recall split times for specific stretches. If you would like to insert a pause during a lap, you can stop the time recording.

Displaying split time or inserting a pause

- Press on the lower section of the rocker switch to **display the split time** ③. While the split time marked with a star is being displayed, the time recording continues to run in the background.
- Press the lower section of the rocker switch again to **insert a pause**. Timing is interrupted, the star in the last row disappears.

Resuming timing

- Press the upper section of the rocker switch to resume timing from the split time or pause display. ■

Switching the display between the lap timer and trip computer

You can retrieve information from the trip computer while the lap timer stopwatch is running.

Selecting the trip computer

- Press the **Reset** button briefly to display the trip computer. You can now operate the trip computer as usual.

Selecting the lap timer

- Press the **RESET** button until the lap timer ⇒ *page 30*, fig. 18 appears. ■

Evaluating times, ending or resetting timing



Fig. 23 Display: Fastest and slowest lap time and average time

After evaluating the lap times, you can reset the lap timer data or continue recording additional laps ⇒ *page 33*.

Ending timing

- To end the last lap, press the upper section of the rocker switch as you finish the lap. The new lap time will not be included in the final evaluation.

Evaluating times

- Press the **Reset** button for approximately two seconds. The most important lap results appear in the display.

Resetting timing

- Press the **Reset** button in the total results display ⇒ fig. 23 for at least two seconds to reset all the lap timer data to zero.

Total lap time results

The following information appears in the display ⇒ fig. 23:

- + the fastest lap time
- the slowest lap time
- Ø the average lap time

Tips

- Saved lap times cannot be individually deleted from the total results.
- In addition to the total results ⇒ fig. 23, only the last two lap times ⇒ *page 31*, fig. 21 can be displayed in the lap timer.
- The saved lap timer values will not be lost after turning the ignition off.
- Lap timer recording can be continued at a later point in time ⇒ *page 33*.
- All values in the lap timer are deleted only when reset is deliberately selected. ■

Resuming timing at a later time

After evaluating the lap times, there is the option to resume and continue timing at a later time.

- Press the **Reset** button until the lap timer ⇒ *page 32*, fig. 23 appears.
- Press the upper section of the rocker switch to record the new lap time.
- Repeat the procedure for recording additional laps as described above ⇒ *page 31*, “Recording additional lap times”. Evaluating the total results ⇒ *page 32*, “Evaluating times, ending or resetting timing”. ■

Speed warning system

Applies to vehicles: with speed warning system

Speed warning system

The speed warning system helps you to keep your driving speed below a set speed limit.



Fig. 24 Display: Speed warning

The speed warning system warns the driver if he exceeds a previously stored maximum speed. A warning tone will sound as soon as the vehicle speed exceeds the set speed by about 3 mph (3 km/h). At the same time, a warning symbol appears in the display ⇒ fig. 24.

The speed warning system has **two warning thresholds** that function independently of each other and that have somewhat different purposes:

Speed warning 1 (Canada models)

You can use speed warning 1 to set the maximum speed while you are driving. This setting will remain in effect until you turn off the ignition, assuming that you have not changed or reset the setting.

The speed warning symbol  (Canada models) in the warning 1 display appears when you exceed the maximum speed. It goes out when the speed falls below the stored maximum speed.

The speed warning symbol will also go out if the speed *exceeds* the stored maximum speed by more than about 25 mph (40 km/h) for at least 10 seconds. The stored maximum speed is deleted.

Setting speed warning 1 ⇒ *page 34*.

Speed warning 2 (Canada models)

Storing warning 2 is recommended if you *always* want to be reminded of a certain speed, for example when you are traveling in a country that has a general maximum speed limit, or if you do not want to exceed a specified speed for winter tires.

The speed warning 2 symbol,  (Canada models) appears in the display when you exceed the stored speed limit. Unlike warning 1, it will not go out until the vehicle speed drops below the stored speed limit.

Setting speed warning 2 ⇒ *page 34*. ▶

Tips

Even though your vehicle is equipped with a speed warning system, you should still watch the speedometer to make sure you are not driving faster than the speed limit. ■

Applies to vehicles: with speed warning system

Speed warning 1: setting a speed limit

Warning threshold 1 is set by the button.



Fig. 25 Section of instrument cluster: Set/Check button

Storing the maximum speed

- Drive at the desired maximum speed.
- Press the knob button ⇒ fig. 25 until the symbol ⇒ page 33, fig. 24 appears.

Resetting the maximum speed

- Drive the vehicle at a speed of at least 3 mph (5 km/h)
- Press the knob for more than 2 seconds.

The speed warning symbol  (USA models)/ (Canada models) will appear briefly in the display when you release the button to indicate that the maximum speed has been stored successfully. The maximum speed remains stored until it is changed by pressing the

button again briefly or until it is deleted by a lengthy push on the button. ■

Applies to vehicles: with speed warning system

Speed warning 2: setting a speed limit

Switches in the wiper arm are used to operate warning threshold 2.



Fig. 26 Controls

To store maximum speed

- Turn off the ignition.
- Briefly press the button in the instrument cluster ⇒ fig. 25. The odometer and the digital clock are now illuminated.
- Press the button for at least 2 seconds. The currently stored maximum speed appears in the display or the crossed out symbol for warning threshold 2, if no maximum speed was set previously.
- Press the function selector switch in the wiper lever  ⇒ fig. 26 up or down to change the set value. Values run up or down in steps of 6 mph (10 km/h). ▶

To delete maximum speed

- Turn off the ignition.
- Briefly press the button in the instrument cluster ⇒ *page 34*, fig. 25. The odometer and the digital clock are now illuminated.
- Press the button for at least 2 seconds. The currently stored maximum speed appears in the display.
- Press the reset button in the wiper lever  ⇒ *page 34*, fig. 26 until the crossed out speed warning symbol for warning threshold 2 appears in the display.

A few seconds after the adjustment is completed, the illumination for the odometer and the digital clock will go out.



Tips





This warning threshold can also be controlled through the trip computer ⇒ *page 28*, “Navigating the menu”. ■

Warnings and symbols

Red symbols

A red symbol means DANGER

- Pull off the road and stop the vehicle.
- Turn off the engine.
- Check the malfunctioning system. Contact your authorized Audi dealer or a qualified workshop for assistance.

	USA models: Malfunction in the brake system	⇒ <i>page 37</i>
 BRAKE	Canada models: Malfunction in the brake system	⇒ <i>page 37</i>
 COOLANT	Engine coolant level too low/ engine coolant temperature too high	⇒ <i>page 37</i>
 OIL PRESSURE	Engine oil pressure too low	⇒ <i>page 38</i>

When a red symbol appears, a warning tone will sound *three* times in succession. The symbol continues to flash until the malfunction has been repaired. If there is *more than one* malfunction, the symbols appear one after the other for about two seconds.



















Tips

- The message for a malfunction can be shown by pressing on the left knob.
- During route guidance on vehicles with a navigation system, the warning symbol is shown in the field above. ■

Yellow symbols

A yellow symbol means WARNING.

	Low fuel level	⇒ <i>page 38</i>
	Check engine oil level	⇒ <i>page 39</i>
	Engine oil sensor malfunction	⇒ <i>page 39</i>

	Worn brake pads	⇒ page 39
	USA models: Speed warning 1	⇒ page 39
	Canada models: Speed warning 1	⇒ page 39
	USA models: Speed warning 2	⇒ page 39
	Canada models: Speed warning 2	⇒ page 39
	Significant loss of air pressure	⇒ page 39
TPMS	Tire pressure monitoring system malfunction	⇒ page 39
	Windshield washer fluid level low	⇒ page 40
	Battery voltage too high or too low	⇒ page 40
	Defective light bulb	⇒ page 40
BRAKE LIGHT	USA models: Defective brake light	⇒ page 40
	Canada models: Defective brake light	⇒ page 40
	Light/rain sensor (automatic headlights) defective	⇒ page 41
	Selector lever defective* No reverse gear*	⇒ page 41
	Clutch is overheating*	⇒ page 41
	Gearbox malfunction*	⇒ page 41

When a yellow symbol appears, a warning tone will sound *once*. Check the displayed function as soon as possible. If *more than one* malfunction is detected, all symbols will appear one after the other for about two seconds. ■

Driver information

In addition to the warning/indicator lights and the symbols in the instrument cluster display, driver information is displayed.



Fig. 27 Section of instrument cluster: Set/Check button

Driver information appears in the display when a defective light bulb is reported by the defective light bulb warning ⇒ page 40, when the brake pads are worn and before you engage a gear on vehicles with R tronic.

In addition, driver information may appear when a red symbol flashes in the driver display.

To display Driver information

As an example, the  symbol appears in the display. If you now press the button ⇒ fig. 27, the following driver message appears in the display:

SWITCH OFF ENGINE AND CHECK OIL LEVEL

The driver message in the display goes out after about 5 seconds. You can display the driver message again by briefly pressing the button. ■

Brake system malfunction

BRAKE (USA models)/(ⓘ) (Canada models)

The indicator light flashes if the brake fluid level is too low, if there is a malfunction in the ABS system or when the parking brake is engaged.

If the **BRAKE**/(ⓘ) symbol flashes in the display with the parking brake released, there is a malfunction in the brake system. In addition to the symbol, one of two messages appears in the display:

STOP VEHICLE AND CHECK BRAKE FLUID

ABS FAULT ! SEE OWNER'S MANUAL

- Pull off the road and stop the vehicle.
- Obtain professional assistance.

USA models: if there is a malfunction in the ABS system, the **ABS** warning/indicator light illuminates along with the **BRAKE** system malfunction warning/indicator light ⇒ ⓘ.

Canada models: if there is a malfunction in the ABS system, the ⓘ warning/indicator light illuminates together with the ⓘ brake system malfunction warning/indicator light ⇒ ⓘ.

Parking brake set

The parking brake warning light **Brake**/(ⓘ) (Canada models) illuminates when the parking brake is set. In addition, a warning tone will sound after you have driven for longer than 3 seconds and faster than 3 mph (5 km/h).

WARNING

- Always observe the warnings in ⇒ *page 191*, “Working in the engine compartment”, before opening the engine compartment lid and checking the brake fluid.
- Driving with low brake fluid is a safety hazard! Stop the car and get professional assistance.
- If the brake system warning/indicator light illuminates together with the ABS warning/indicator light, then the ABS system is malfunctioning. The rear wheels could quickly lock up when you apply the brakes. This could lead to loss of control and your vehicle could slide! Drive carefully to the nearest authorized Audi dealer and have the malfunction corrected. ■

Engine cooling system malfunction

A malfunction in the engine cooling system must be repaired as soon as possible.

When the  symbol in the display flashes, then either the engine coolant *temperature* is too high, or the coolant *level* is too low. In addition to the symbol, the following message also appears in the display:

SWITCH OFF ENGINE AND CHECK COOLANT LEVEL

- Pull off the road and stop the vehicle.
- Turn off the engine.
- Check coolant level ⇒ *page 198*.
- Add coolant if necessary ⇒ *page 199*.
- Continue driving only after the engine coolant warning/indicator light goes out. ▶

- Contact your authorized Audi dealer for assistance if necessary.

If the engine coolant level is correct, then the radiator fan may be the cause of the malfunction.

If the generator warning/indicator light should also illuminate ⇒ *page 19*, then the fan belt may be damaged.

WARNING

- If your vehicle should break down for mechanical or other reasons, park at a safe distance from moving traffic, turn off the engine and turn on the hazard warning lights ⇒ *page 57*, “Emergency flasher ”.
- Never open the engine compartment lid if you see or hear steam or coolant escaping from the engine compartment - you risk being scalded. Wait until you can no longer see or hear steam or coolant escaping.
- The engine compartment of any vehicle is a dangerous area. Before you perform any work in the engine compartment, turn off the engine and allow it to cool. Follow the warning stickers ⇒ *page 191*, “Working in the engine compartment”.

Note

Do not continue driving if the  symbol illuminates. There is a malfunction in the engine cooling system – you could damage your engine. ■

Engine oil pressure malfunction

The red engine oil pressure warning symbol requires immediate service or repair.

If the  symbol appears in the display and flashes, the oil pressure is too low. In addition to the symbol, the following message also appears in the display:

SWITCH OFF ENGINE AND CHECK OIL LEVEL

- Pull off the road and stop the vehicle.
- Shut the engine down.
- Check the engine oil level ⇒ *page 195*.
- Contact your authorized Audi dealer for assistance if necessary.

Engine oil level too low

If the engine oil level is too low, top off oil to the proper level ⇒ *page 196*.

Engine oil level OK

If the  symbol starts flashing again even though the engine oil level checks OK on the dipstick, **do not start driving again and do not let the engine run at idle**. Instead, contact your authorized Audi dealer for assistance. ■

Fuel supply too low

When the  symbol illuminates, this means there are about 2.6 gallons (10 liters) of fuel left in the fuel tank. Time to refuel! ⇒ *page 187*.

If the symbol lights up, even when there is ample fuel in the tank, and the text **TANK SYSTEM MALFUNCTION ! CONTACT WORKSHOP** ►

appears in the display, there is a fault in the system. Contact a qualified workshop to have the fault rectified. ■

Checking the engine oil level

Please add max. 1 qt of engine oil!

If the  symbol comes on, add 1 quart (1 liter) of oil at the next opportunity ⇒ *page 196*. ■

Engine oil sensor defective

If the  symbol illuminates, contact your authorized Audi dealer and have the oil sensor inspected. ■

Worn brake pads

If the  symbol illuminates, contact your authorized Audi dealer to have the front brake pads inspected (on that occasion have the rear brakes inspected as well to be safe). ■

Speed warning 1 (USA models)/ (Canada models)

If the  symbol illuminates, this means you are driving faster than the set vehicle speed. Slow down! ⇒ *page 33*. ■

Speed warning 2 (USA models)/ (Canada models)

If the  symbol illuminates, this means you have driven faster than the second set vehicle speed. Slow down! ⇒ *page 33*. ■

Significant loss of air pressure

Tire pressure that is too low must be corrected as soon as possible.

If the  warning light comes on and the message **Please check tire pressure** appears in the display, pressure in at least one tire is too low.

- Stop driving as soon as possible without endangering yourself and other drivers on the road.
- Inspect all tires.
- Correct the tire pressure ⇒ *page 211*.

Additional information about the **tire pressure monitoring system** can be found: ⇒ *page 224*. ■

Tire pressure monitoring system malfunction TPMS

A malfunction can have various causes.

If the  warning light in the instrument cluster flashes for approximately one minute and then remains continuously illuminated and additionally the **TPMS** symbol appears in the display, the tire pressure monitoring system is not available. The text **Tyre pressure! System malfunction** appears in the display. This can have various causes.

- A wheel sensor or other component may have failed.
- During initialization the system has detected more than 4 wheels on the vehicle, for example while driving next to another car with a tire pressure monitoring system.
- Audi replacement parts were not used.
- If snow chains are being used, system function can be compromised due to the shielding properties of the chains. ►

- The tire pressure monitoring system may not be available because of a radio malfunction.
- Transmitters with the same frequency, such as radio headphones in the vehicle or radio equipment, can cause a temporary disruption of the system through excessive electromagnetic fields.
- Eliminate the interference if you can and then proceed as follows: Turn off the engine for 20 minutes. Then drive another 10 min. If the warning light comes on again, you should contact your authorized Audi dealer immediately to have the problem corrected.
- Do not use commercially available tire sealants. Otherwise, the electrical components of the tire pressure monitoring system will no longer work properly and the sensor for the tire pressure monitoring system will have to be replaced by a qualified workshop. ■

Windshield washer fluid level too low

If the  symbol illuminates, add windshield washer fluid to the washer system ⇒ *page 204*. ■

Battery voltage low

If the  symbol illuminates, contact your authorized Audi dealer and have the following components inspected:

- drive belt
- battery charge

Also see if the generator warning/indicator light illuminates ⇒ *page 19*. ■

Defective light bulb warning

The defective light bulb warning tells you when a vehicle light bulb has become defective.

If a defective bulb has been detected by the system or a light bulb burns out, the  symbol with a message appears in the display to tell you which bulb is burnt out and where it is located. For example:

REAR LEFT TURN SIGNAL

After 5 seconds, the message disappears. If you want to recall the message into the display, press the CHECK button ⇒ *page 12, fig. 2* .

There are three reasons why the defective bulb message would appear in the display:

- The light bulb has burnt out ⇒ *page 248*.
- The fuse is “blown” ⇒ *page 245, “Replacing a fuse”*.
- The wire connection to the light bulb is defective.

Have the bulb replaced or the connection repaired by your authorized Audi Service department.

WARNING

- **Light bulbs are pressurized and could explode while they are being changed causing serious personal injury.**
- **Work with due care when handling the high-voltage section of gas discharge (xenon) lamps. Failing to do so could result in death or serious injury!** ■

Brake light defective **BRAKE LIGHT** (USA models)/ (Canada models)

In case of a malfunction or component failure, the symbol **BRAKE LIGHT** (USA models)/ (Canada models) can appear. The following elec- ►

trical components should be checked, repaired or replaced, as necessary:

- Brake light bulbs
- All wiring connections
- Brake light switch

Contact your authorized Audi dealer for assistance if necessary.



Tips

The brake light switch is only inspected as part of the functional check after the engine is started. ■

Applies to vehicles: with automatic headlights

Light/rain sensor defective

The indicator light indicates a defect in the automatic headlights/automatic wiper system.

If the symbol illuminates, the light sensor has failed. For safety reasons, the low beams are turned on permanently with the switch in **AUTO**. However, you can continue to turn the lights on and off using the light switch. In the case of a defect in the rain sensor, the windshield wiper lever functions are still available. Have the light/rain sensor checked as soon as possible at an authorized Audi dealer. ■

Applies to vehicles: with R tronic

Selector lever defective and

Selector lever defective! No reverse gear!

If the symbols are illuminated, there is a malfunction in the R tronic selector lever. The selector lever displays go out or flash. It is not possible to engage reverse gear. If you have been shifting the transmission manually, it switches to automatic operation.

You can continue to shift the transmission manually. From the neutral position N, engage first gear by tapping the shift button  on the steering wheel. Then the transmission remains in manual operation and you can select the gears using the shift buttons.

Have the selector lever checked as soon as possible at an authorized Audi dealer or other qualified workshop. ■

Applies to vehicles: with R tronic

Clutch is overheating and

Clutch is overheating ! If possible please stop vehicle

If the symbols are illuminated, the clutch is overheating and could be damaged if you continue to drive.

Stop your vehicle and allow the engine to run at idle for several minutes. This will cool the clutch. ■

Applies to vehicles: with R tronic

Gearbox malfunction

In the event of a system malfunction, R tronic switches to emergency operation mode.

Gearbox malfunction! You can continue driving

You can continue to drive the vehicle. See an authorized Audi dealer or other qualified workshop at the next opportunity.

Gearbox malfunction! You can continue driving but functions are restricted

There is a serious system malfunction:

- The program shifts only into certain gears.
- The engine may stall.
- It is not possible to restart the engine if it has been switched off.
- Continuing to drive could result in subsequent damage. ■

Opening and closing

Keys

Key set

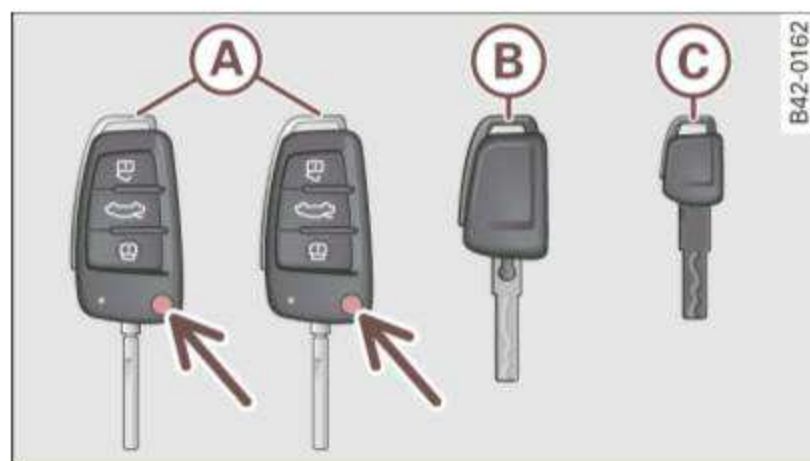

Fig. 28 Key set



Fig. 29 Remote master key: Indicator light

Your Audi comes with four keys ⇒ fig. 28:

- (A) two master keys with remote control
- (B) one valet key
- (C) one emergency key

Master key with remote control

You can centrally lock and unlock your vehicle and start the engine with the master key with remote control. To fold the key out and back in place, press the release button ⇒ fig. 28 (arrow).

Valet key

The valet key only fits the lock in the driver's door and the ignition lock. If you have to leave the key with somebody else, you are well-advised to turn over the valet key only.

Be aware that the front lid and glove compartment can be opened from inside the vehicle using the release buttons.

Emergency key

The emergency key is only for temporary use if the vehicle key should be lost or misplaced.

Key replacement

If you lose a key, contact your authorized Audi dealer immediately to have the *lost* key disabled. Be sure to bring all your keys with you.

If a key is lost, you should report it to your insurance company.

Registered keys

You can inquire about the number of remote master keys registered to your vehicle ⇒ *page 26*. In this way, you can be certain of obtaining all the remote master keys if you purchase a used vehicle.

State of master key battery

When a button is pressed, the check light flashes ⇒ fig. 29. If the check light does not come on or flash, the battery is dead and has to be replaced.

Battery replacement ⇒ *page 43*.



WARNING

- Do not leave your vehicle unattended with the key in the ignition lock. Entry by unauthorized persons could endanger you or result in theft or damage the vehicle. Always lock all doors and take the key.
- Do not leave children unattended in the vehicle, especially with access to vehicle keys. Unguarded access to the keys provides children the opportunity to start the engine and/or activate vehicle systems such as the power windows etc. Unsupervised operation of any vehicle system by children can result in serious injury.

Tips

If you open the driver's door with the key left in the ignition lock, a chime will sound. This is your reminder to remove the key and lock the door. ■

Master key with remote control

The remote control allows you to lock or unlock the vehicle electronically.

The transmitter and battery are located in the head of the remote control. The receiver is located inside the vehicle. The maximum effective range depends on several things. Remember, if the battery is weak, the effective range decreases.

If you need to replace the remote control, or if you need to have it repaired, you must see your authorized Audi dealer. Only then can you use the key again.



Tips

- If the ignition is switched on, the remote control system is deactivated.

- The remote control system can be affected by other systems operating in the same frequency range close to the vehicle, such as mobile telephones, television broadcasting stations, etc. ■

Resetting the remote control

The remote control must be reset if the vehicle does not unlock.

- Press the unlock  button on the remote control.
- Within 30 seconds, lock the vehicle once at the door lock using the stem of the remote control key.
- Press the unlock button  or the lock button . ■

Master key battery replacement

Each master key contains a battery housed under the cover.

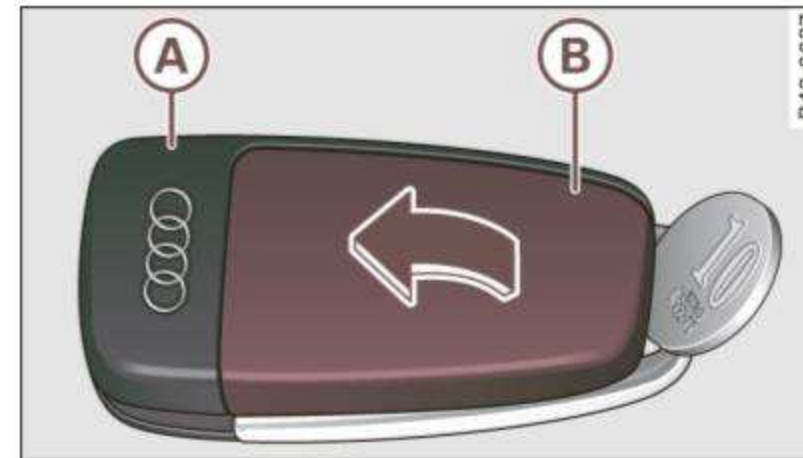

Fig. 30 Remote master key: opening the cover

We recommend having the battery changed by an authorized Audi dealer. However, if you wish to replace the dead battery yourself, proceed as follows: ▶

- Pry apart the base ⇒ *page 43*, fig. 30 **(A)** and the cover **(B)** **carefully** with a coin.
- Remove the cover (arrow).
- Remove the dead battery from the cover.
- Install the new battery. Please make certain that the “+” sign on the battery faces down. Correct polarity is shown on the cover.
- Place the cover with the new battery on the key base and press both parts together.



For the sake of the environment

Dispose of dead batteries properly so as not to pollute the environment.



Tips

The replacement battery must be the same specification as the original. ■

Electronic immobilizer

The immobilizer helps to prevent unauthorized use of your vehicle.

A computer chip inside your key automatically deactivates the electronic immobilizer when you insert the key in the ignition lock, or when the Advanced Key is located inside the vehicle. When you remove the key from the ignition lock or remove the Advanced Key from the vehicle, the electronic immobilizer is automatically activated once again.

If an unauthorized key was used, **SAFE** is displayed continuously in the odometer display field.



WARNING

Always take the key with you when you leave the vehicle. The key can disarm the electronic engine immobilizer and permit an unauthorized person to start the engine and enable operation of the vehicle systems such as power window or power sunroof leading to serious personal injury.



Tips

- Your engine can only be started using the factory-equipped key.
- You may not be able to start your vehicle if an ignition key of a different vehicle make is also located on your set of keys. ■

Power locking system

General description

The power locking system locks or unlocks all doors simultaneously.

When opening and closing the doors, the power locking system locks or unlocks *both* doors together.

The remote master key locks and unlocks the doors using a radio signal ⇒ *page 46*.

Locking and unlocking with the key

You can also lock and unlock your vehicle using the key in the lock on the driver's door. However, note that which door is unlocked *mechanically* when the vehicle is opened depends on the settings in the menu display ⇒ *page 26*. To disarm the anti-theft alarm system, insert the key in the ignition lock and switch the ignition on within 15 seconds of opening the driver's door. If the ignition is not switched on within 15 seconds, the alarm is triggered. ►

Both doors are locked automatically when the vehicle is locked and the anti-theft alarm system is activated.

Windows

You can also open or close the windows when you lock or unlock the driver's door using the key ⇒ *page 46*. For safety reasons, you cannot use the remote control to open/close the windows.

Break-in security feature

The power locking system is equipped with a **break-in security feature**. When the vehicle is locked from the outside, the inside door levers are disabled. This makes attempts to break into the vehicle more difficult.

You also have the option of locking your vehicle without activating the break-in security feature.

In the driver's door lock: Turn the key in the driver's door lock the locking position twice within 2 seconds.

Auto Lock

The **Auto Lock** function locks all doors and the front lid once speed has exceeded approximately 9 mph (15 km/h).

The car is unlocked automatically once the ignition key is removed. In addition, the vehicle can be unlocked if the power locking system opening function  is activated or one of the door levers is used. If desired, the Auto Lock function can be reconfigured through the menu display ⇒ *page 26* or by a qualified workshop.

Turn signals

All the turn signals flash to indicate when the vehicle is locked and unlocked. The turn signals flash twice when the vehicle is unlocked. The turn signals flash once when all the doors and the front lid are locked. The interior lights are also switched on or off automatically according to the position of the door contact switch.



WARNING

- When you lock your vehicle from outside, nobody - especially children - should remain inside the vehicle. Remember, when you lock the vehicle from the outside the windows cannot be opened from the inside.
- When you leave the vehicle, always remove the ignition key and take it with you. This will prevent passengers (children, for example) from accidentally being locked in the vehicle should they accidentally press the power locking switch on the center console.
- Do not leave children inside the vehicle unsupervised. In an emergency it would be impossible to open the doors from the outside without the key.



Tips

- The driver's door can be locked and unlocked with the key if the power locking system fails. The passenger's door can be locked manually ⇒ *page 48*.
- In the event of a crash with airbag deployment all locked doors will be automatically unlocked to give access to the vehicle occupants from the outside.
- The break-in security feature and the anti-theft alarm system cannot be activated if the power locking system is not activated.
- You are well advised not to keep valuables inside an unattended vehicle, visible or not. Even a properly locked vehicle cannot provide the security of a safe! ■

Unlocking and locking the vehicle with the remote control

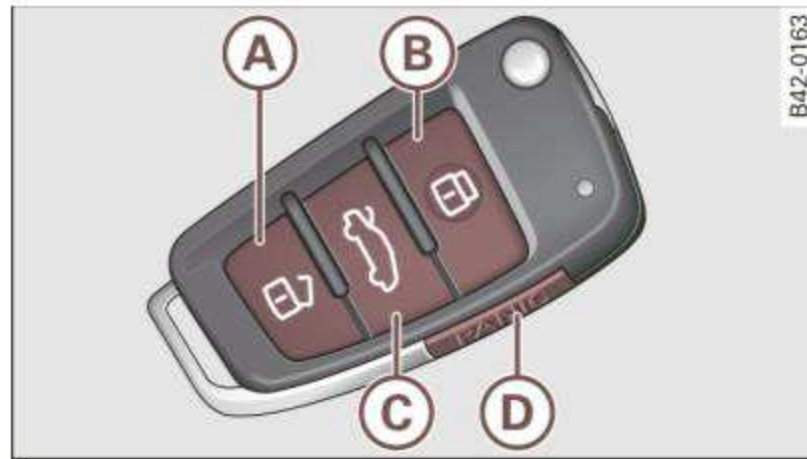



Fig. 31 Remote control: function buttons

To unlock the vehicle

- Press button **A** once ⇒ fig. 31.

To lock the vehicle

- Press button **B** once ⇒ .

To unlock front lid only

- Press button **C** for approximately one second.

PANIC Button

- Push the red button **D** to activate the panic function. The horn sounds and the turn signals flash.
- Push the button **D** again to deactivate the panic function.

The turn signals flash twice when the vehicle is unlocked. If the vehicle is unlocked and a door or the front lid are not opened within the next 30 seconds, the vehicle locks again automatically. This feature prevents the vehicle from being left unlocked accidentally for a long period of time.

The turn signals briefly flash once when the doors and front lid are locked properly.

WARNING

Read and follow all WARNINGS ⇒  in “General description” on page 44.

Tips

- Use the remote control only when the doors and front lid are closed.
- In order to make sure the locking function is working, you should always keep your eye on the vehicle to make sure it is properly locked.
- Do not use the remote control if you are inside the car, otherwise you may unintentionally lock the vehicle, and then you would set off the anti-theft alarm when you try to start the engine or open a door. In case this happens anyhow, push the unlock button .
- You can only open and close the windows when the “convenience opening” function is activated in the menu display ⇒ page 26.
- Use the panic function only if you are in an emergency situation. ■

Operating locks with the key

To lock and unlock the vehicle from the outside, turn the key in the lock of the driver's door.

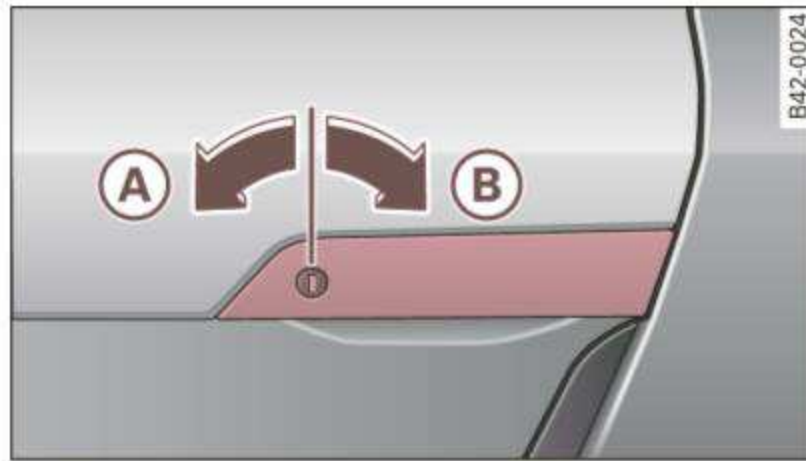

Fig. 32 Key turns for opening and closing

To unlock the vehicle

- Turn the key *one time* to position (A) to unlock the driver's door ⇒ fig. 32.

To lock the vehicle

- Turn the key in the lock of the driver's door to the lock position (B) ⇒ ⚠.
- Turn the key in the driver's door lock cylinder **a second time within two seconds** to the locked position (B) to lock the vehicle **without activating the break-in security feature**.

To close all windows

- Turn and hold the key in the lock position (B) ⇒ fig. 32 until the windows are completely closed ⇒ ⚠.

To open all windows

- Turn and hold the key in the open position (A).

⚠ WARNING

- Be careful when closing the windows. Check to see that no one is in the way, or serious injury could result!
- Always read and heed WARNING ⇒ ⚠ in "General description" on page 44.

i Tips

- The break-in security feature and the anti-theft alarm system cannot be activated if the power locking system is not activated.
- However, note that which door is unlocked *mechanically* when the vehicle is opened depends on the settings in the menu display ⇒ page 26.
- Both doors are locked automatically when the vehicle is locked. ■

Locking and unlocking the vehicle from inside

The vehicle can be locked or unlocked from the inside using the power locking switch.

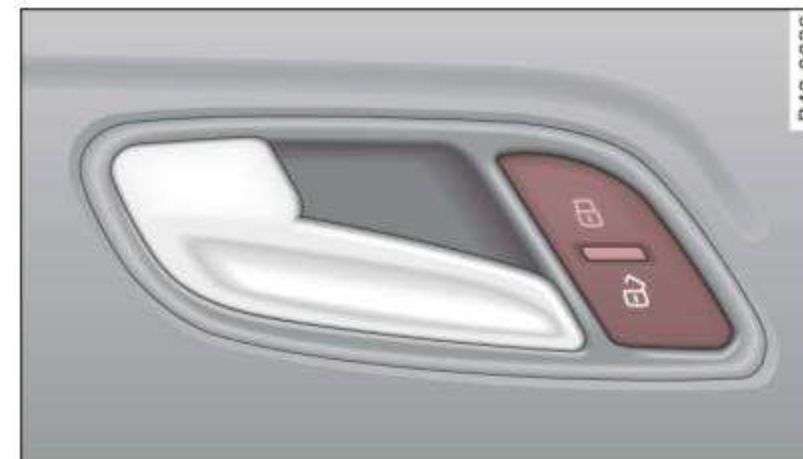



Fig. 33 Section from driver's door: Power locking switch

To lock the vehicle

- Press the upper part of the power locking switch  ⇒ fig. 33 ⇒ ⚠.

To unlock the vehicle

- Press the lower part of the switch .

If you lock the vehicle using the power locking switch, please note the following:

- You cannot open the doors or the front lid from the *outside* (increased security, for example when you are stopped at a red light).
- The LED in the power locking switch lights up when all the doors and the front lid are closed and locked.
- You can unlock and open the doors from the inside by pulling on the door handle.
- If the driver's door is opened (after you have locked the vehicle from the inside using the power locking switch), the door will remain unlocked to prevent you from locking yourself out of your vehicle. After you close the door, you have to lock the driver's door again.
- If you have a crash and the airbag is activated, the doors automatically unlock.

WARNING

- If you use the power locking switch with the doors closed, remember that all the vehicle doors will lock.
- Locking doors from the inside can help prevent inadvertent door opening during an accident and can also prevent unwanted entry from the outside. Locked doors can, however, delay assistance to vehicle occupants and hold up rescue efforts from the outside in an accident or other emergency.

Tips

When the break-in security feature is activated, the power locking system switch is disabled. ■

Emergency locking

If the power locking system fails (power failure), you will need to lock the passenger door separately.



Fig. 34 Emergency lock location on the front passenger's door



Fig. 35 Emergency locking

For this purpose, a mechanical locking device is provided on the end panel of the passenger door (only visible when the door is open).

- Open the door.
- Remove the cap ⇒ fig. 34.
- Insert the key into the inner slot ⇒ fig. 35 and turn it about 90 degrees to the right as far as it can go. ►

- Replace the cap.

After you close the door you will no longer be able to open it from the outside. You can open it from the inside, however, by pulling on the door latch twice. ■

Front lid

Opening and closing the front lid



Fig. 36 Drivers door: remote front lid release



Fig. 37 Release lever under the front lid

When opening the front lid, the windshield wipers must be switched off and the wiper arms must be folded against the windshield. Otherwise the paint could be damaged.

Opening the front lid

- Press the center button on the master key or
- Pull the release button in the driver's door ⇒ fig. 36.
- Pull up on the release under the front lid ⇒ fig. 37 (arrow). This releases the catch.
- Open the front lid all the way.

Closing the front lid

- Pull the front lid down until the pressure from the struts is reduced.
- Close the front lid.
- Press the front lid closed carefully using both hands until it latches audibly ⇒ ⚠.

⚠ WARNING

A front lid that is not completely latched could fly up and block your view while driving.

- When you close the front lid, check it to make sure the safety catch has properly engaged. The lid should be flush with the surrounding vehicle body parts.
- If you notice while driving that the lid is not secured properly, stop at once and close it.
- Never leave your vehicle unattended especially with the front lid left open. A child could crawl into the luggage compartment and pull the lid shut, becoming trapped and unable to get out. To reduce the risk of personal injury, never let children play in or around your vehicle. Always keep the front lid as well as the vehicle doors closed when not in use.

Note

Make sure there are no objects protruding above the edge of the luggage compartment. Otherwise, the front lid could be damaged.

Tips

If the front lid is open or not properly locked when the ignition is turned on, the door and front lid warning appears in the instrument cluster display. ■

Emergency release for front lid

If the front lid cannot be opened, an emergency release is provided.



Fig. 38 Section: Emergency release

- Reach under the closed glove compartment. There is a red plastic cord under the glove compartment.
- Pull the red plastic cord towards you. ■

Anti-theft alarm system

Description

The anti-theft alarm triggers an alarm if anyone attempts to break into the vehicle.



Fig. 39 Diode position in the instrument panel

The anti-theft alarm system triggers an audible alarm and turns on the emergency flasher if an unauthorized interference with the vehicle is sensed by the system.

How is the anti-theft alarm system switched on?

The anti-theft alarm system is switched on when you lock the driver's door manually using the fold-out key, or when you use the remote control. The system is activated approximately 30 seconds after the vehicle is locked. The indicator light \Rightarrow fig. 39 starts flashing rapidly for 30 seconds and then blinks slowly.

How is the anti-theft alarm system switched off?

The anti-theft alarm system is switched off only when you use the remote control to unlock your vehicle. If you do not open a door within 30 seconds after you have unlocked with the remote control, the vehicle will lock itself again automatically.

If you lock just the driver's door using your key, the front passenger's door remains locked. ►

When will the anti theft alarm system be triggered?

When the vehicle is locked, the alarm system monitors and protects the following parts of the vehicle:

- engine compartment
- luggage compartment
- doors
- ignition

When the system is activated, the alarm will be triggered if one of the doors, the engine compartment lid or the front lid are opened, or if the ignition is turned on.

The anti-theft alarm system will also go off when the battery is disconnected.

You can also trigger the alarm by pressing the PANIC button on your remote-control key. This will alert other people in case of emergency. Press the **PANIC** button again to turn off the alarm.

How is the anti-theft alarm switched off when triggered?

The alarm system is switched off when you unlock the vehicle using the remote-control key or when the ignition is switched on. The alarm will also switch itself off when it comes to the end of its cycle.

Emergency flasher

The emergency flasher will blink briefly when the doors, engine compartment lid and front lid are properly closed.

If the emergency flashers do not blink, check the doors, engine compartment lid and front lid to make sure they are properly closed. If you close a door, the engine compartment lid or the front lid with the anti-theft alarm switched on, the emergency flashers will blink only after you have closed the door or lid.

Tips

- For the anti-theft alarm system to function properly, make sure all vehicle doors and windows are closed before leaving the vehicle.

- When you open the vehicle from the driver's door using the key, the central locking switch will work only after you have switched on the ignition. ■

Power windows

Controls

The driver can operate all windows.

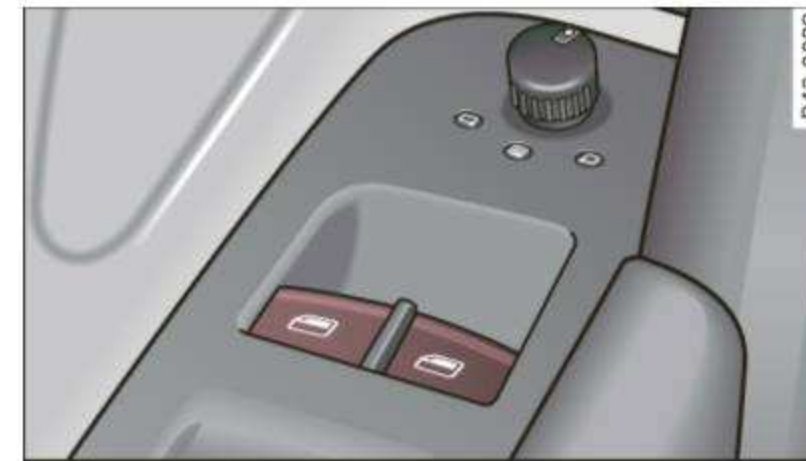

Fig. 40 Driver's door: power window switches



Fig. 41 Passenger's door: power window switch

The power window switches have a **two-position function**: ►

Opening the windows

- Press the switch and **hold it down** until the window has reached the desired position.
- Press the switch **briefly** to open the window automatically.

Closing the windows

- Pull the switch and **hold it** until the window has reached the desired position.
- Pull the switch **briefly** to close the window automatically.

WARNING

- **Do not leave children unattended in the vehicle, especially with access to vehicle keys. Unsupervised use of the keys can result in starting of the engine and use of vehicle systems such as power windows, etc. which could result in serious injury.**
- **Remember – you can still open or close the power windows for about ten minutes after the ignition is switched off. Only when either of the front doors are opened are the power windows switched off.**
- **Be careful when closing the windows. Check to see that no one is in the way, or serious injury could result!**
- **Always remove the ignition key whenever you leave your vehicle.**
- **If you lock your vehicle from the outside, no one, especially children, should remain in the vehicle.**
- **Do not stick anything on the windows or the windshield that may interfere with the driver's field of vision.**

Tips

- When the doors are opened, the windows are automatically lowered 0.4 in (10 mm).
- You can also open the windows using the remote master key ⇒ *page 46.* ■

Reactivating the system after battery disconnection

If the vehicle battery is disconnected and then reconnected, the automatic closing and opening function will not work until it is reactivated. To reactivate this feature, perform the following steps:

- Pull and hold the power window switch until the window is completely closed.
- Release the switch. Pull the switch again for one second. The automatic closing/opening is now reactivated. ■

Clear vision



Lights

Switching the headlights on and off



Fig. 42 Instrument panel: light switch

Switching on the side marker lights

- Turn the light switch light to . The indicator light  comes on.

Switching on the headlights and high beam

- Turn the light switch to .
- Push the high beam lever forward towards the instrument panel \Rightarrow *page 57*.

Switching off the lights

- Turn the light switch to **O**.

The headlights only work when the ignition is switched on. While starting the engine or when switching off the ignition, the headlights will go off and only the side marker lights will remain lit.

If the rotary light switch is in the **0** or **AUTO** position, the daytime running lights are turned on when the ignition is switched on if they were activated via the menu display \Rightarrow *page 26*.

WARNING

Crashes can happen when you cannot see the road ahead and when you cannot be seen by other motorists.

- Always turn on the headlights so that you can see ahead and so that others can see your car from the back.
- Never use daytime running lights to see where you are going. They are not bright enough and will not let you see far enough ahead for safety, especially at dusk or when it is dark. Be aware of changes in outside light conditions when you are driving and respond by switching on your low beams .

Tips

- If you remove the ignition from the ignition lock while the headlights are still on, a buzzer will sound as long as the driver's door is open to remind you to switch off the lights.
- Always observe the specific local regulations for your area when to use your lights.
- In cool or damp weather conditions the headlights may fog over temporarily on the inside.
 - The critical factor is the temperature difference between the interior and the exterior of the headlight lens.
 - With the main beams switched on, the light-emitting area will be free of condensation after a short time, however the edges of the glass may still be fogged.
 - This physical phenomenon has no effect on the life of your vehicle's lighting system. 

- Turn on low beams as evening approaches or in conditions of poor visibility. ■

Applies to vehicles: with light sensor package

Sensor activated head and tail light control

In the "AUTO" position light sensors switch the head and tail lights on and off.



Fig. 43 Instrument panel: light switch

The sensor-activated low beams have the same characteristics as the headlights ⇒ *page 53*.

Activating

- Turn the light switch ⇒ *fig. 43* to position **AUTO**.

Deactivating

- Turn the light switch to position **O**.

In the switch position **AUTO** the automatic head- and taillight control is activated. The corresponding symbol on the light switch is lit.

With automatic headlights, the high-beam function is also available, but with one restriction: If you have not switched the high beams back to low beams during automatic headlight operation (for

example, after driving through a tunnel), only the low beams come on the next time automatic headlights are switched on. To use the high beams, you first have to pull the high beam lever back and then push the lever forward again.

The side marker lights and headlights can be switched on manually using the light switch ⇒ *page 53*.

Light sensors located in the inside mirror housing and stem constantly check the light conditions surrounding the vehicle. If ambient brightness falls below a factory set value (e.g. when driving into a tunnel), the head- and taillights including the license plate illumination are automatically turned on. When ambient brightness increases again, the external lights are turned off again ⇒ ⚠.

Light sensor malfunction

If there is a light sensor malfunction, the symbol 🚦 comes on in the display. For safety reasons, the low beams are turned on permanently with the switch in **AUTO**. However, you can continue to turn the lights on and off using the light switch. Have the light sensor checked as soon as possible at an authorized Audi dealer.

⚠ WARNING

- **Automatic head- and taillight control is only intended to assist the driver. This feature does not relieve the driver of his responsibility to check the headlights and to turn them on manually according to the current light and visibility conditions. For example, fog and rain cannot be detected by the light sensors. Consequently, always switch the headlights 🚦 on under these weather conditions and when driving in the dark.**
- **Crashes can happen when you cannot see the road ahead and when you cannot be seen by other motorists.**
- **Always turn on the headlights so that you can see ahead and so that others can see your car from the back.**

Tips

- In the **AUTO** mode, the low beams are turned off when the ignition is turned off. The remaining lights are turned off when the key is taken out of the ignition lock.
- Do not attach stickers to the windshield in front of the sensors as this can disable the automatic head- and taillight control and the automatic glare-dimming of the rearview mirror(s). ■

Applies to vehicles: with coming home/leaving home function

Coming home/leaving home function

The coming home/leaving home function switches on the external lights on a vehicle parked in the dark to illuminate the surroundings.



Fig. 44 Dashboard detail: coming home/leaving home switch

Activating the function

- Tap the switch  ⇒ fig. 44. The indicator light in the switch illuminates.

Deactivating the function

- Tap the switch . The indicator light in the switch goes out.

The coming home/leaving home function is controlled by light sensors located in the inside mirror mount. The system is activated if all of the conditions below are fulfilled:

- The window in the switch  illuminates.
- The driving lights and the ignition have been switched off.
- The vehicle is parked in poor light or darkness with the sensors detecting little or no light at all.
- The leaving home function in the menu display is activated ⇒ page 26.

Coming home situation

When it is dark and the system is activated, the low beams and rear lights, the engine compartment lights* and the license plate lights are switched on as soon as the driver's door is opened.

As long as one of the doors or the front lid remains open, the set of external lights will keep burning for about four minutes maximum.

To provide light for departure, the set of vehicle lights will keep burning for about another 30 seconds after all doors and the front lid have been closed.

The time until the lights are switched off can be adjusted. Have the adjustment done by your authorized Audi dealer or a qualified workshop.

Leaving home situation

If the leaving home function is activated in the menu display, the low beams and rear lights, the engine compartment lights* and the license plate lights are switched on when the vehicle is unlocked with the  button on the remote key ⇒ page 26.

Opening the driver's door switches off the low beams and the engine compartment lights*. If the driver's door is not opened, the low beams and the engine compartment lights* switch off when the vehicle is automatically locked again ⇒ page 43. ▶

Tips

- If you wish to use the coming home/leaving home function regularly, you can leave it activated at all times without risking permanent strain on the electrical system. As the system is controlled by light sensors, it will only be energized in darkness.
- Frequent use of the coming home/leaving home function for approaching and departing a vehicle parked in the dark will strain the battery. This applies particularly if only short distances are driven between stops. Occasionally drive longer distances to make sure the battery is recharged sufficiently.
- Please observe legal regulations when using the lighting systems described. ■

Instrument panel illumination

The illumination of the instruments, displays and the center console can be adjusted.



Fig. 45 Instrument panel illumination

You regulate the brightness of the instruments with the left thumb-wheel  ⇒ fig. 45.

A phototransistor integrated into the instrument cluster controls the illumination of the needles in it. When the lights are switched on, the lighting for the center console and the instruments (needles

and dials) is automatically adjusted to ambient conditions. The driver can also adjust the brightness of the lighting.

Ignition ON, light switch at

With the ignition switched ON, the glow of *instrument needles* can be adjusted to appear brighter or dimmer.

Ignition ON, light switch at or .

With the lights switched on, the brightness of instrument cluster (i.e. needles, gauges and displays) and center console illumination can be adjusted.

Note

The instrument cluster and center console illumination (gauges and needles) comes on when you switch on the ignition and the **vehicle headlights are off**. Be aware of the following difference between models built to US or Canadian specifications:

- USA models: illumination of the instrument cluster (gauges and needles), dash and center console around the gearshift lever is controlled by a light sensor located in the instrument panel. The instrument panel illumination will automatically become dimmer as the daylight fades away and eventually will go out completely when outside light is very low. This is to remind you, the driver, to switch on the headlights before it gets too dark.
- Canada models: instrument panel illumination will stay bright regardless of the intensity of ambient light. Always be aware of changes in outside light conditions while you are driving. Respond in time to fading daylight by turning the light switch to position  (or "AUTO" if your car is equipped with this feature) to turn on your headlights. ■



Emergency flasher

The emergency flasher makes other motorists aware that you or your vehicle are in an emergency situation.



Fig. 46 Center console: emergency flasher switch

- Press the switch  ⇒ fig. 46 to switch the emergency flasher on or off.

When the emergency flasher is on, all four turn signal blink at the same time. The turn signal indicator lights   in the instrument cluster, as well as the light in the emergency flasher switch  blink likewise. The emergency flasher also works when the ignition is switched off.

The emergency flasher will automatically switch on if you are in an accident where the airbag has deployed.

Tips

You should switch on the emergency flasher when:

- you are the last vehicle standing in a traffic jam so that any other vehicles coming can see you, or when
- your vehicle has broken down or you are in an emergency situation, or when
- your vehicle is being towed by a tow truck or if you are towing another vehicle behind you. ■

Turn signals and high beam lever

The lever is used to operate the turn signals and the high beam as well as the headlight flasher.



Fig. 47 Turn signal and high beam lever

The turn signal and high beam lever has the following functions:

Turn signals

- Lift the lever up all the way ⇒ fig. 47 to use the right turn signals, or push the lever down all the way to use the left turn signals.
- Move the lever (up or down) just to the point of resistance to use the turn signals for as long as you need them, for example when changing lanes.
- Briefly move the lever up or down just to the point of resistance and then release it to flash the turn signals *three times in succession*. This **Convenience turn signal** function must be activated in the menu display ⇒ page 26.

High beam





- Push the lever forward to switch on the high beam. ►

- Pull the lever back towards you to switch off the high beam.

Headlight flasher

- Pull the lever toward the steering wheel to use the headlight flasher.

Notes on these features

- The *turn signals* only work with the ignition switched on. The indicator lights  or  in the instrument cluster \Rightarrow *page 16* also blink.
- After you have turned a corner, the turn signal switches off automatically.
- The *high beam* works only when the headlights are on. The indicator light  in the instrument cluster illuminates when the high beams are on.
- The *headlight flasher* works only as long as you hold the lever - even if there are no lights switched on. The indicator light  in the instrument cluster illuminates when you use the headlight flasher.



Note

Do not use the high beam or headlight flasher if you know that these could be blinding oncoming traffic. ■

Interior lights

Interior lights

The interior lights include the reading lights for the driver and the front passenger.

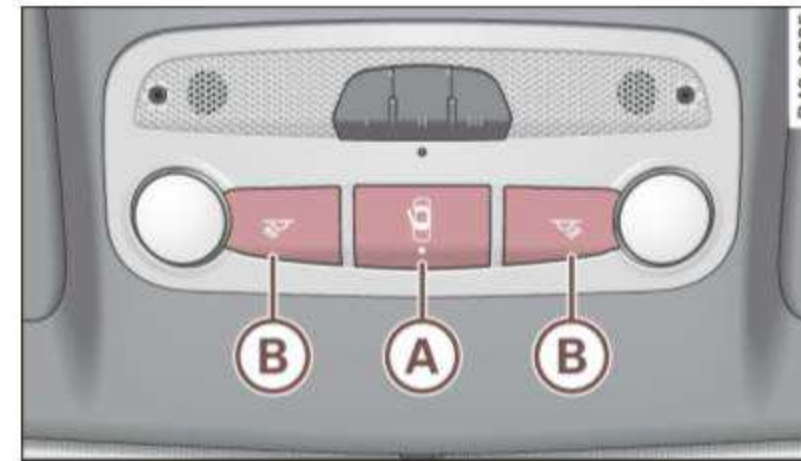

Fig. 48 Section from headliner: Interior lights

Activating door contact circuit

- Press the button **(A)**. The LED in the button illuminates.

Deactivating door contact circuit

- Press the button **(A)**. The LED in the button goes out.

Front reading lights

- Press one of the switches **(B)** to turn the right or left reading light on or off.

With the door contact circuit, the interior lights turn on as soon as you unlock the vehicle or open the doors. The interior lights are also turned on when the ignition key is removed. The lights turn off about 30 seconds after the doors are closed. When the vehicle is locked or when the ignition is turned on, the interior lights are turned off.

When a door is open, the interior lights are turned off after about 10 minutes to prevent battery draining.

The brightness of the lights is controlled automatically by a dimmer when they are switched on and off. ■

Luggage compartment light

The light is located on the right side of the luggage compartment. These lights come on automatically when the front lid is opened. The lights turn off automatically if the lid is left open for more than 10 minutes. ■

Applies to vehicles: with engine compartment lights

Engine compartment lights

The lights are located on the left and right side of the engine compartment.

The lights switch on automatically when the coming/leaving home function* is activated ⇒ *page 55*. ■

Vision

Sun visors

Using the sun visors makes driving safer.

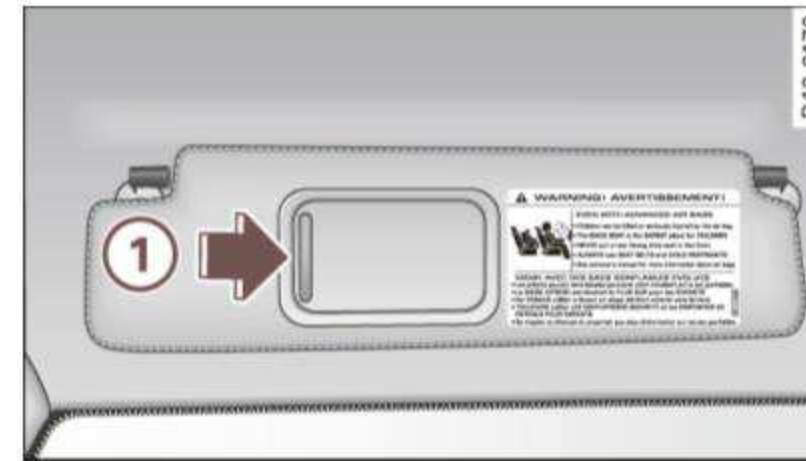

Fig. 49 Sun visor

The vanity mirrors in the sun visors are equipped with covers. ■

Wiper and washer system

Windshield wiper

The windshield wiper lever controls both the windshield wipers and the washer system.

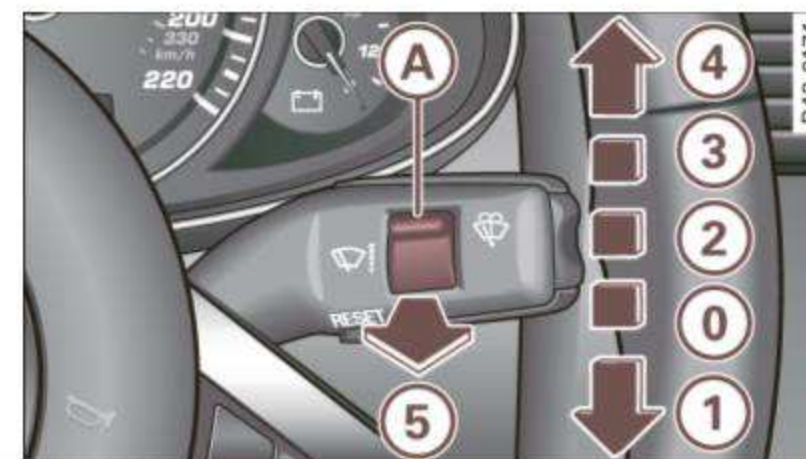

Fig. 50 Wiper lever

The windshield wiper lever ⇒ *page 59*, fig. 50 has the following positions:

One-touch wiping

- Move the lever to position ①, when you want to wipe the windshield *briefly*.

Intermittent wiping (activating rain sensor)*

- Move the lever up to position ②.
- Move the switch A to set the duration of the wipe intervals or to adjust the sensitivity of the light/rain sensor*.

Low wiper speed

- Move the lever up to position ③.

High wiper speed

- Move the lever up to position ④.

Automatic wiper/washer

- Pull the lever to position ⑤ (toward the steering wheel) and hold.
- Release the lever. The washer system stops and the wipers continue to operate for about 4 seconds. Different numbers of wipe cycles are performed depending on how long the lever is held.

Turning off the wipers

- Move the lever back to position ①.

Moving wiper blades to the service position

- Do **not** lift the wiper arms away from the glass when they are in their parked position; this would damage the paint on the front lid.
- When there is a risk of frost, make sure that the wiper blades are not frozen to the windshield.
- Move wiper blades to the service position ⇒ *page 61*.

The windshield wipers and washer only work when the ignition is turned on.

To reduce the sensitivity of the sensor, move switch A down. To increase the sensitivity, move the switch up. The higher you adjust the sensitivity, the faster the sensor will react when it senses moisture on the windshield. The pauses between wiper turns depend not only on the sensitivity setting, but on the vehicle speed as well.

During a temporary stop, e.g. at a traffic signal, the set wiper speed is automatically reduced by one stage.

When the ignition is turned on, the washer jets are heated.

WARNING

- **Wiper blades are crucial for safe driving! Only when they are in good condition are they able to clear the windows properly to provide uncompromising visibility. Worn or damaged wiper blades are a safety hazard ⇒ *page 62*, "Replacing front wiper blades"!**
- **The light/rain sensor* is only designed to assist and support the driver. It remains entirely the driver's responsibility to monitor outside weather conditions and to manually activate the wipers as soon as rain or drizzle reduces visibility through the windshield.**
- **The windshield must not be treated with water-repellent materials. They can increase glare under poor visibility conditions such as wetness, darkness, or when the sun is low on the horizon. In addition, they can cause the windshield wipers to chatter.**

! Note

In freezing or near freezing conditions:

- Always check that the wiper blades are not frozen to the glass before you turn the wipers on. Loosen a wiper blade which is frozen in place before operating the wipers to prevent damage to the wiper blade or the wiper motor.
- Do not use the wipers to clear a frosted window. Using the wipers as a convenient ice scraper will destroy the wiper blades.
- Before you take your vehicle to an automatic car wash, make sure you have the windshield wiper system switched off (lever in position 0), otherwise the windshield wiper system could get damaged in the car wash if it should suddenly come on.

i Tips

- Make sure the washer fluid reservoir is topped off before going on a long trip. Look up ⇒ *page 204* for checking and filling the washer container.
- Worn or dirty windshield wiper blades cause smearing, which can affect the operation of the light/rain sensor*. Check the condition of your windshield wiper blades regularly.
- If you switch off the ignition with the windshield wiper lever still in the interval wipe position and then come back a while later and drive off, the rain sensor will reactivate itself after the vehicle speed has exceeded 4 mph (6 km/h).
- Applies to vehicles with light/rain sensor: When the wipers are switched on manually and in rain conditions, the automatic headlights* turn on ⇒ *page 54*, "Sensor activated head and tail light control" or off during the day when the wipers are no longer operating. The automatic headlights* function is available in this case only when the light switch is in the "AUTO" position ⇒ *page 54*, fig. 43. ■

Service position

It is only possible to change wiper blades if you move the wiper arms to the service position



Fig. 51 Wiper lever

In order to use the windshield wipers, the front lid must be completely closed

Moving wiper blades to the service position

- When there is a risk of frost, make sure that the wiper blades are not frozen to the windshield.
- Switch the ignition on.
- Move the wiper lever to position **0**.
- Press the **Reset** button until the **Display type** menu appears in the Driver Information System display.
- Using the rocker switch and the **Reset** button, select the **Set > Wipers > Front > Service position on** function. The windshield wiper arms move to the service position.

Moving wiper blades to park position

- Make certain that the wiper arms are lying against the windshield. ▶

- Switch the ignition on and move the wiper lever
⇒ *page 61*, fig. 51 from position **0** to **1**. The wiper arms will move back to the park position.

! Note

Never drive your vehicle when the windshield wiper arms are in the service position and pulled away from the windshield. When you drive faster than 4 mph (6 km/h), the wiper arms automatically return to the park position and could cause paint damage to the front lid!

i Tips

- You can also turn on the service position, for example, if you want to protect the windshield from icing by using a cover.
- The service position moves to **off** automatically when you operate the windshield wiper lever, or speed exceeds 4 mph (6 km/h). ■

Replacing front wiper blades

Wiper blades in good condition help keep the windshield clear.

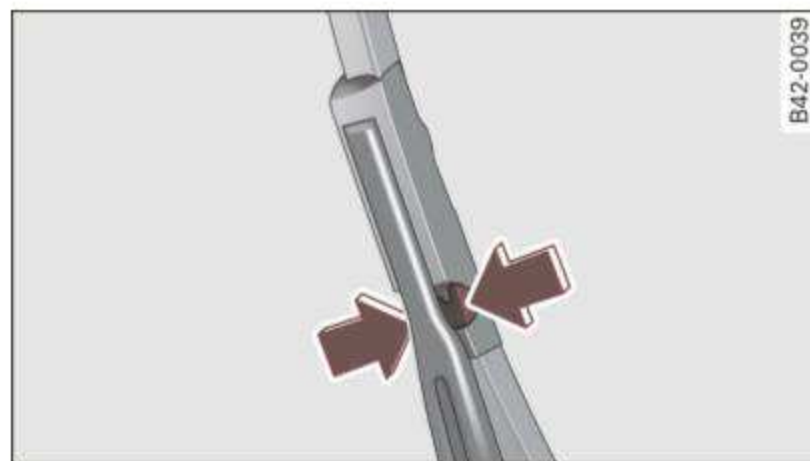

Fig. 52 Unlatching wiper blades

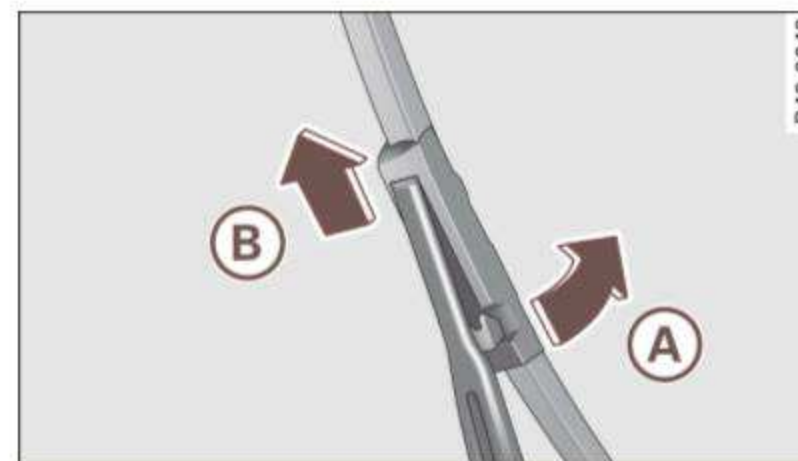

Fig. 53 Removing wiper blades

Removing the wiper blade

- Move the wipers to the service position ⇒ *page 61*.
- Fold the windshield wiper arm away from the glass.
- On the upper end of the wiper arm at the corrugation, squeeze the plastic retainer together on both sides in the direction of the arrow ⇒ fig. 52.
- Rotate the wiper blade in the direction of the arrow (A) ⇒ fig. 53 away from the wiper arm.
- Lift the wiper blade off in the direction of the arrow (B).

Installing the wiper blade

- Place the rounded end of the wiper onto the end of the wiper arm in the **opposite** direction to the arrow (B) ⇒ fig. 53.
- Squeeze the corrugation on the wiper until you hear it click in the wiper arm.
- Fold the wiper arm back onto the windshield.
- Switch the ignition on and move the wiper lever down briefly ⇒ *page 61*, fig. 51. The wiper will move back to the park position. ▶

WARNING

- Clean your wiper blades regularly with a windshield washer solution to prevent streaking. If the wiper blades are very dirty, for example with insects, carefully clean the wiper blades with a sponge or a soft brush.
- For your safety, you should replace the wiper blades once or twice a year. See your authorized Audi dealer for replacement blades.

Note

- The wiper blades may only be changed ⇒ *page 61* in the service position! Otherwise, you risk damaging the paint on the front lid or the windshield wiper motor.
- To prevent damage to the wiper system:
 - Always loosen blades which are frozen to the windshield before operating wipers.
 - Do not use gasoline, kerosene, paint thinner, or other solvents on or near the wiper blades.
 - Do not attempt to move the wipers by hand.

Tips

The front wiper blades are different lengths; the blade on the driver's side is longer. ■

Mirrors

Manual glare dimming

Standard setting

- Move the small lever (located on the bottom edge of the mirror) to the front.

Anti-glare setting

- Move the small lever (located on the bottom edge of the mirror) to the rear. ■

Applies to vehicles: with automatically dimming inside rearview mirror

Automatically dimming inside mirror

The automatic dimming function can be turned on and off if required.

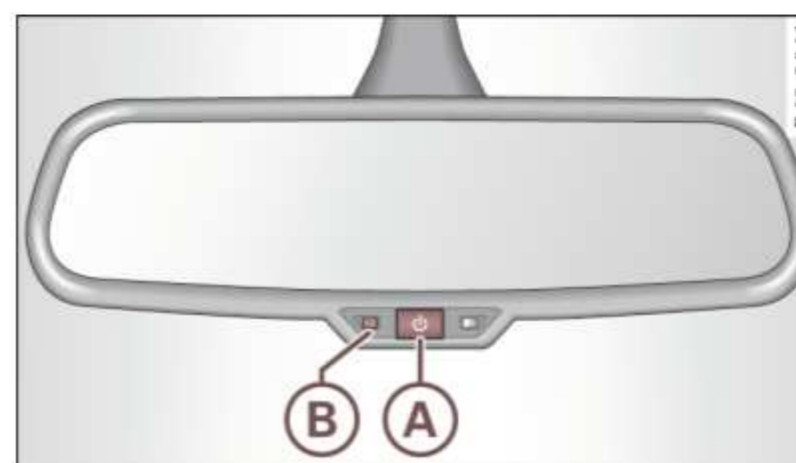

Fig. 54 Inside rearview mirror: auto dimming on/off button and indicator light

Disabling auto dimming

- Press button **A** ⇒ fig. 54 - the green indicator light **B** goes out.

Activating/reactivating auto dimming

- Press button **A** ⇒ fig. 54 - the green indicator light **B** goes on.

Automatic dimming function

The automatic dimming function is activated every time the ignition is turned on. The green indicator light is lit to indicate auto dimming is active.

When dimming is activated, the inside mirror will darken *automatically* in response to the amount of light striking the mirror (such as ►

headlights from rearward approaching vehicles). Even in dimming mode, the mirror surface turns bright when:

- the interior light is switched on
- reverse gear is engaged.

Sensors for automatic headlights

With the help of the sensors in the mirror, when the light switch is in the **AUTO** position, the low beams are switched on and off automatically depending on the ambient light conditions ⇒ page 54.

WARNING

The glass of the inside rearview mirror is layered and contains an electrolyte to achieve its properties. Be aware of liquid electrolyte leaking from a broken mirror glass. This liquid can cause irritation to skin, eyes, and respiratory system.

- If you get electrolyte in your eyes or on your skin, immediately rinse with plenty of water. If irritation persists, seek medical attention.

Note

Liquid electrolyte leaked from a broken mirror glass will damage any plastic surfaces it comes in contact with. Clean up spilled electrolyte immediately with clear water and a sponge.

Tips

- If you switch off the automatic dimming function on the inside mirror, automatic dimming of the outside mirrors will likewise be disabled.
- Check to make sure there are no objects preventing light from reaching the inside mirror.
- Do not attach any stickers to the windshield in front of the two light sensors, as this would interfere with both the automatic oper-

ation of the headlights and the automatic dimming of the inside mirror(s). ■

Outside mirrors

The outside mirrors are electrically adjusted.

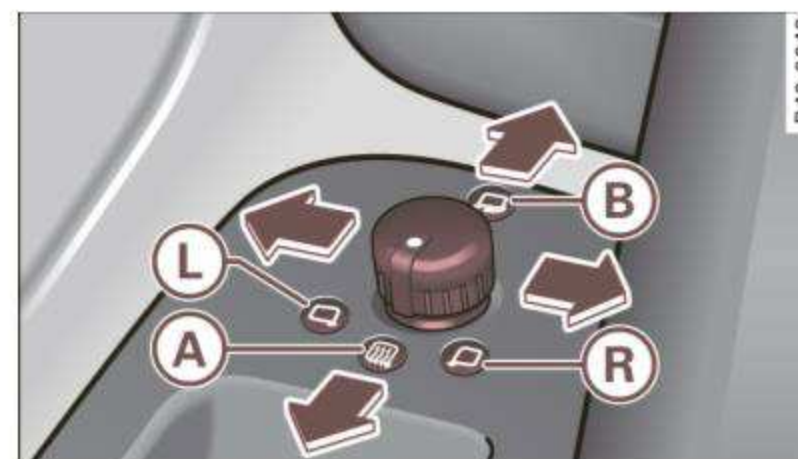

Fig. 55 Forward section of driver's armrest: power mirror controls

Adjusting the outside mirrors

- Turn the adjusting knob to position **L** (driver's side) or in position **R** (passenger side) ⇒ fig. 55.
- Press the knob in the appropriate direction to move the mirror surface so that you have a good view to the rear.

Heated mirrors

- Turn the knob to position **A**.

Folding both outside mirrors flat*

- Turn the knob to **B**.

Depending on the outside temperature, the mirror surfaces are heated until the ignition is switched off - even if the knob is no longer in position **A**.

We recommend folding* the outside mirrors flat to help when parking your vehicle or when maneuvering in very tight spaces.

! Note

- Curved (i.e. convex) mirror surfaces increase your field of view. Remember that vehicles or other objects will appear smaller and farther away than when seen in a flat mirror. If you use this mirror to estimate distances of following vehicles when changing lanes, you could estimate incorrectly and cause an accident.
- If the mirror housing is moved unintentionally (for example, while parking your vehicle), then you must first fold the mirror electrically. Do not readjust the mirror housing manually. You could damage the motor which controls the mirror.

i Tips

If there should be a malfunction in the electrical system, you can still adjust the outside mirrors by pressing the edge of the mirror. ■

Applies to vehicles: with automatic dimming for outside mirrors

Automatic dimming for outside mirrors

The outside mirrors are dimmed together with the automatic dimming of the inside mirror. When the ignition is switched on, the mirrors darken automatically depending on the light striking them (e.g. headlights from the rear).

When the interior lighting is switched on and when reverse gear is engaged, the mirrors are switched back to their original brightness (not dimmed).

! WARNING

The glass of the inside rear view mirror is layered and contains an electrolyte to achieve its properties. Be aware of liquid electrolyte leaking from a broken mirror glass. This liquid can cause irritation

! WARNING (continued)

to skin, eyes, and respiratory system. If you get electrolyte in your eyes or on your skin, immediately rinse with plenty of water. If irritation persists, seek medical attention.

! Note

Electrolyte leaking from a broken mirror glass attacks the vehicle paint and plastic surfaces. Clean up spilled electrolyte immediately with clear water and a sponge.

i Tips

- If automatic dimming for the inside mirror is switched off, the outside mirrors are also not dimmed automatically.
- Automatic dimming for the mirror only operates properly if the light striking the inside mirror is not hindered by other objects. ■

Digital compass

Applies to vehicles: with digital compass

Activating or deactivating the compass

The direction is displayed on the interior rear view mirror.

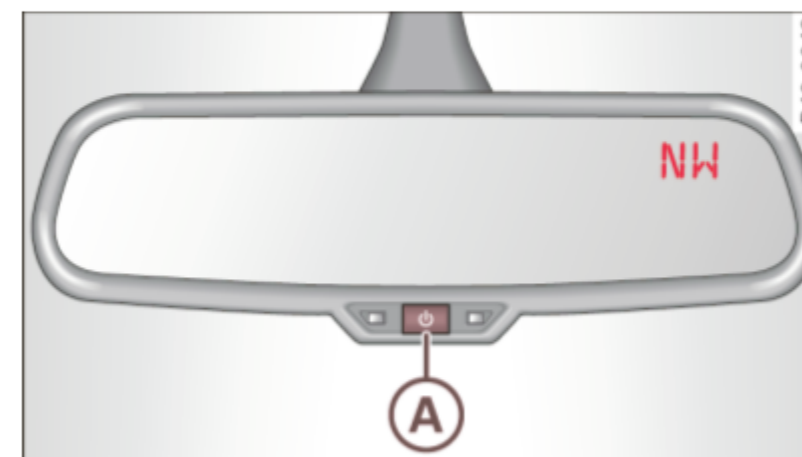

Fig. 56 Inside rear view mirror: digital compass activated

- To activate or deactivate, hold the **(A)** button down until the red display appears or disappears.

The digital compass only works with the ignition turned on. The directions are displayed as initials: **N** (North), **NE** (Northeast), **E** (East), **SE** (Southeast), **S** (South), **SW** (Southwest), **W** (West), **NW** (Northwest).

i Tips

To avoid inaccurate directions, do not allow any remote controls, electrical systems, or metal parts close to the mirror. ■

Applies to vehicles: with digital compass

Setting the magnetic deflection zone

The correct magnetic deflection zone must be set in order to display the directions correctly.

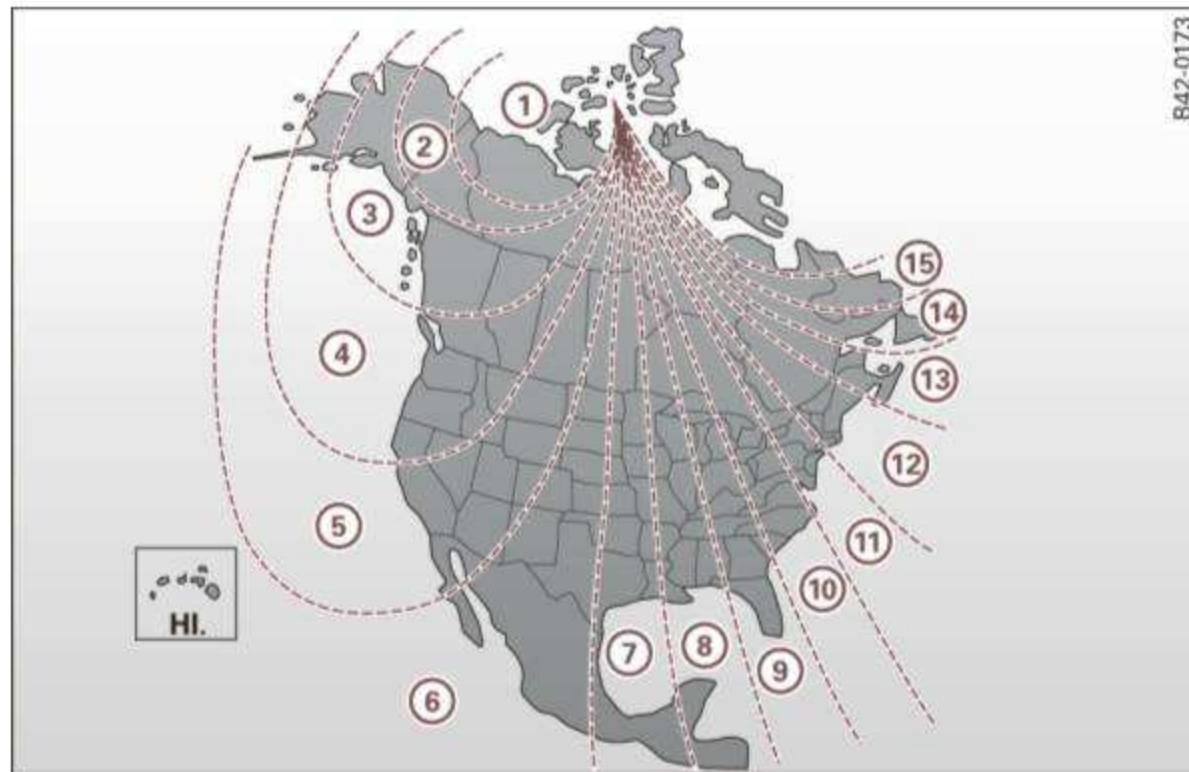

Fig. 57 Magnetic deflection zone boundaries

- Hold the **(A)** button ⇒ *page 65, fig. 56* down until the number of the set magnetic deflection zone appears on the interior rear view mirror.
- Adjust the magnetic deflection zone by repeatedly pressing on the **(A)** button. The set mode automatically deactivates after a few seconds. ■

Applies to vehicles: with digital compass

Calibrating the compass

The compass has to be recalibrated if the display is wrong or inaccurate.

- Hold the **(A)** button down until the letter **C** is displayed on the interior rear view mirror.
- Drive in a circle at a speed of about 5 mph (10 km/h) until a direction is shown on the interior rear view mirror.

! WARNING

The digital compass is to be used as a directional aid only. Even though you may want to look at it while you are driving, you must still pay attention to traffic, road and weather conditions as well as other possible hazards. ■

Seats and storage

General recommendations

Why is your seat adjustment so important?

The safety belts and the airbag system can only provide maximum protection if the front seats are correctly adjusted.

There are various ways of adjusting the front seats to provide safe and comfortable support for the driver and the front passenger. Adjust your seat properly so that:

- you can easily and quickly reach all the switches and controls in the instrument panel
- your body is properly supported thus reducing physical stress and fatigue
- the safety belts and airbag system can offer maximum protection ⇒ *page 125*.

In the following sections, you will see exactly how you can best adjust your seats.

There are special regulations and instructions for installing a child safety seat on the front passenger's seat. Always heed the information regarding child safety provided in ⇒ *page 147, "Child Safety"*.

WARNING

Incorrect seating position of the driver and all other passengers can result in serious personal injury.

- **Always keep your feet on the floor when the vehicle is in motion – never put your feet on top of the instrument panel, out of the window or on top of the seat cushion! This applies especially to the passengers. If your seating position is incorrect you increase the risk of injury in the case of sudden braking or an accident. If**

WARNING (continued)

the airbag inflates and the seating position is incorrect this could result in personal injury or even death.

- **It is important for both the driver and front passenger to keep a distance of at least 10 inches (25 cm) between themselves and the steering wheel and/or instrument panel. If you're sitting any closer than this, the airbag system cannot protect you properly. In addition to this, the front seats and head restraints must be adjusted to your body height so that they can give you maximum protection.**
- **Always try to keep as much distance as possible between yourself and the steering wheel or instrument panel.**
- **Do not adjust the driver's or front passenger's seat while the vehicle is moving. Your seat may move unexpectedly, causing sudden loss of vehicle control and personal injury. If you adjust your seat while the vehicle is moving, you are out of position. ■**

Driver's seat

The correct seat position is important for safe and relaxed driving.

We recommend that you adjust the driver's seat in the following manner:

- Adjust the seat in fore and aft direction so that you can easily push the pedals to the floor while keeping your knee slightly bent ⇒  in "Why is your seat adjustment so important?".
- Adjust the seatback so that when you sit with your back against the seatback, you can still grasp the top of the steering wheel. ▶

- Position the head restraint according to the occupant's height ⇒ *page 70*. For maximum protection, the top of the head restraint should be at least at eye level, preferably higher and ideally level with the top of the head ⇒ *page 110, fig. 88*.

WARNING

Never place any objects in the driver's footwell. An object could get into the pedal area and interfere with pedal function. In case of sudden braking or an accident, you would not be able to brake or accelerate! ■

Front passenger's seat

Always move the front passenger seat into the rearmost position.

To avoid contact with the airbag while it is deploying, do not sit any closer to the instrument panel than necessary and always wear the three-point safety belt provided adjusted correctly. We recommend that you adjust the passenger's seat in the following manner:

- Move the front passenger seat into the rearmost position of the fore and aft adjustment range ⇒  in "Why is your seat adjustment so important?" on *page 67*.
- Bring the backrest up to an (almost) upright position. **Do not** ride with the seat reclined.
- The ideal position for the head restraint is with the upper edge of the restraint level with the top of your head ⇒ *page 70*. You should *not* lower the top of the restraint below the level of your eyes.

- Place your feet on the floor in front of the passenger's seat. ■

Power seats

Applies to vehicles: with power seats

Adjustment switches

The operating logic for the switches corresponds to the construction and function of the seat.



Fig. 58 Adjustment switches: locations on driver seat

The operating logic for the switches corresponds to the construction, the design and the function of the seat. Push or pull either switch in exactly the same direction you want the corresponding part of the seat to move.

Adjustment switches

- ① Adjusting the lumbar support
- ② Adjusting seat height and fore-and-aft position
- ③ Adjusting the angle of the seatback
- ④ Releasing the seatback ■

Applies to vehicles: with power seats

Power seat adjustment

The switches can be moved in various directions to allow precise adjustment.

Read and heed all warnings before you adjust your seat.

⇒ .

Adjusting the curvature of the lumbar support*

- Push the forward or rear depression on the switch shell  ⇒ page 68, fig. 58 to increase or decrease the backrest curvature.

Adjusting the height of the lumbar support*

- Push the top or bottom depression on the switch shell  to raise or lower the support in the backrest.

Moving the front seats forward or backward

- Press the switch  forward or backward horizontally.

Adjusting the seat height

- Pull or push the switch  evenly at both ends to raise or lower the seat.

Angling the seat cushion up and down (front)

- Pull or push the switch  at the front only to raise or lower the seat.

Angling the seat cushion up and down (rear)

- Pull or push the switch  at the rear only to raise or lower the seat.

Adjusting the seatback

- Push or pull the switch  in the same direction you want the seatback to tilt

Releasing seat back

- Pull the lever  up.
- Push the seatback forward.

WARNING

- Never adjust the driver's or front passenger seat while the vehicle is moving. If you do this while the vehicle is moving, you will be out of position. Always adjust the driver's or front passenger seat when the vehicle is not moving.
- Be careful when adjusting the seat height. Check to see that no one is in the way, or serious injury could result!
- Because the seats can be electrically adjusted with the ignition key removed, never leave children unattended in the vehicle. Unsupervised use of the electric seat adjustments may cause serious injury.
- To reduce the risk of injury in the case of sudden braking or accident, front passengers must never ride in a moving vehicle with the seatback reclined. Safety belts and the airbag system offer maximum protection only when the seatback is upright and the safety belts are properly positioned on the body. The more the seatback is reclined, the greater the risk of personal injury from an incorrect seating position and improperly positioned safety belts!
- Always make sure the front seatbacks are in the upright position and securely locked in place when driving. ■

Head restraints

Adjusting head restraints, front seats

The head restraints must be adjusted properly to provide protection.

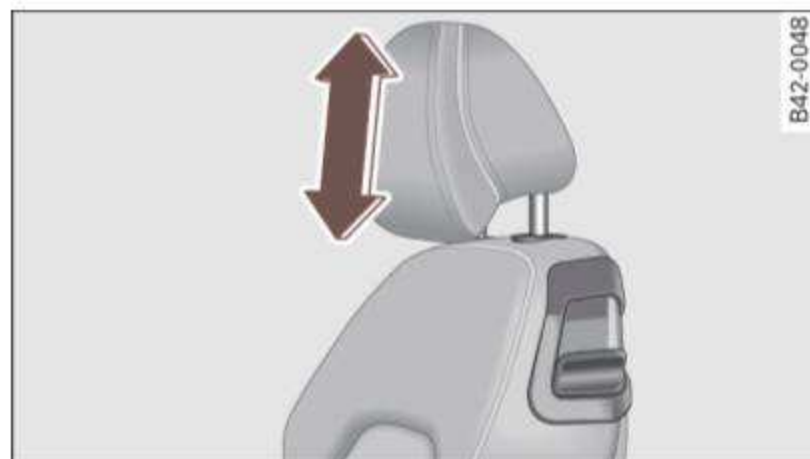

Fig. 59 Head restraints

- Grasp the side of the head restraint with both hands.
- Adjust the head restraints so that the top of the head restraint is *at least* level with your eyes or higher.

The head restraints can be adjusted to provide safe support to head and neck at the optimum height.

WARNING

- Driving without head restraints or with head restraints that are not properly adjusted increases the risk of serious or fatal neck injury dramatically.
- Read and heed all WARNINGS ⇒ page 110. ■

Cup holder

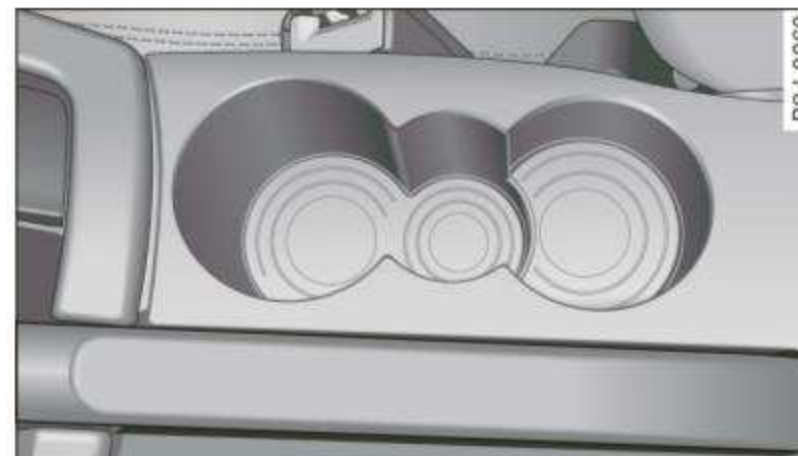

Fig. 60 Cup holder

WARNING

Spilled hot liquid can cause an accident and personal injury.

- Never carry any beverage containers with hot liquids, such as hot coffee or hot tea, in the vehicle while it is moving. In case of an accident, sudden braking or other vehicle movement, hot liquid could spill, causing scalding burns. Spilled hot liquid can also cause an accident and personal injury.
- Use only soft cups in the cupholder. Hard cups and glasses can cause injury in an accident.
- Never use the cupholder or adapter as an ashtray - risk of fire.

Note

Only drink containers with lids should be carried in the cupholder. Liquid could spill out and damage your vehicle's electronic equipment or stain the upholstery, etc. ■

Ashtray

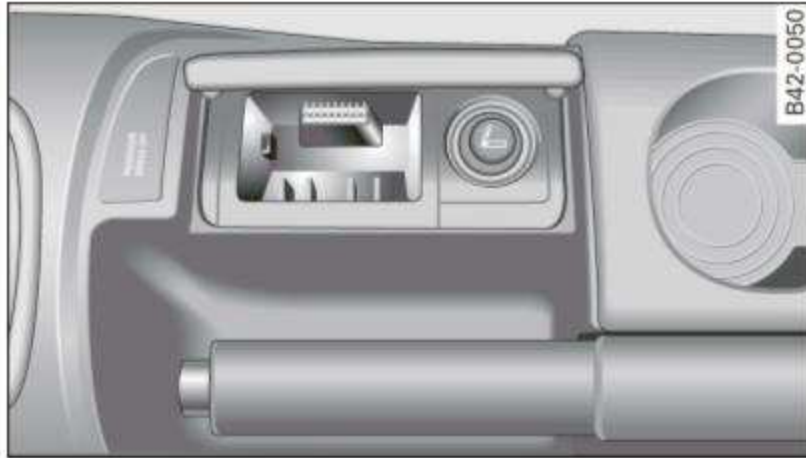

Fig. 61 Center console: ashtray

Opening the ashtray

- Slide the cover open.

Removing ashtray insert

- Lift the cover all the way to the right.
- Pull the ashtray insert up and out.

To reinstall ashtray

- Press the ashtray insert back into its holder.

WARNING

Never put waste paper in the ashtray. Hot ashes or other hot objects in the ashtray could set waste paper on fire. ■

Cigarette lighter/socket

The cigarette lighter or socket only work with the ignition on.

Using the cigarette lighter

- Slide the cover open to reach the cigarette lighter
⇒ *page 71*.
- Push the knob in.
- Wait until the cigarette lighter knob pops out.
- Remove the cigarette lighter immediately and use it.
- Reinsert cigarette lighter into the socket after use.

Connecting an appliance

- Slide the cover open to reach the cigarette lighter.
- Remove cigarette lighter.
- Plug in appliance to be used.

The socket of the cigarette lighter may be used for 12-volt appliances with maximum consumption of up to 100 watts, such as a flash light, small vacuum cleaner, etc.

WARNING

Improper use of the cigarette lighter can cause serious injury or start a fire.

- Be careful when using the cigarette lighter. If you do not pay attention to what you are doing when you are using the cigarette lighter you can burn yourself.

Note

- To avoid damaging the socket, only use plugs that fit properly.
- Only use the cigarette lighter socket as a power source for electrical accessories for short durations. Use the sockets in the vehicle when a power source is needed for longer durations. ▶

Tips

- When the engine is off and accessories are still plugged in and are on, the vehicle battery can still be drained.
- The vehicle battery must not be charged with a standard small charger that plugs into the cigarette lighter or outlet. ■

Storage

General

WARNING

- Always remove objects from the instrument panel. Any items not put away could slide around inside the vehicle while driving or when accelerating or when applying the brakes or when driving around a corner.
- When you are driving make sure that anything you may have placed in the center console or other storage locations cannot fall out into the footwells. In case of sudden braking you would not be able to brake, depress the clutch or accelerate.
- Any articles of clothing that you have hung up must not interfere with the driver's view. The coat hooks are designed only for lightweight clothing. Never hang any clothing with hard, pointed or heavy objects in the pockets on the coat hooks. During sudden braking or in an accident - especially if the airbag is deployed - these objects could injure any passengers inside the vehicle. ■

Glove compartment

The glove compartment is illuminated and can be locked.



Fig. 62 Glove compartment

To open glove compartment

- Pull the handle ⇒ fig. 62 in the direction of the arrow, push down lid to the fully open position.

To close glove compartment

- Push the glove compartment lid upward until the lock engages.

The glove compartment light comes on as the parking or driving lights are switched on and the compartment is opened. You will find a glasses case in the lid.

The glove compartment has a standard 12-volt socket for connecting electrical accessories. The power consumption at the outlet must not exceed 100 watts. The socket works only with the ignition switched on.

WARNING

To reduce the risk of personal injury in an accident or sudden stop, always keep the glove compartment closed while driving. ■

Applies to vehicles: with storage compartment in the front seats

Storage compartment in the front seats

There is a fold-out storage compartment in the front of the seats.

Opening

- Lift the handle and pull the drawer out.

Closing

- Push the drawer in completely until it latches.



Tips

The maximum carrying capacity 2.2 lbs (1 kg). ■

Coat hooks

WARNING

- Hang clothes in such a way that they do not impair the driver's vision.
- The coat hooks must only be used for lightweight clothing. Do not leave any heavy or sharp edged objects in the pockets which may interfere with the side airbag deployment and can cause personal injury in a crash.
- Do not use coat hangers for hanging clothing on the coat hooks as this can interfere with proper deployment of the side airbag head-protection in an accident.
- Do not hang heavy objects on the coat hooks, as they could cause personal injury in a sudden stop. ■

Warm and cold

Climate controls

Controls

The climate controls automatically maintain the selected temperature in the vehicle interior throughout each season.



Fig. 63 Climate controls

We recommend the following setting:

- Rotate the knob ⇒ fig. 63 ② to the right to switch on the air conditioning.
- Set the temperature to 72 °F (22 °C).
- Press the AUTO ⇒ fig. 63 button.

Using the previously recommended setting is the quickest way to achieve a comfortable climate in the vehicle. This setting should therefore only be changed when personal comfort levels or certain circumstances require it.

The climate controls are a combination of automatic heating and ventilation systems and a cooling system which dehumidifies and cools the air inside the vehicle.

The climate controls automatically maintain a temperature once it has been set. The temperature of the air from the vents, fan speed (air volume) and air distribution are also automatically adjusted. The system also takes into account strong sunshine so that manual adjustment is not necessary. So in almost all cases, **automatic mode** offers the best conditions for the comfort of the occupants at all times of the year ⇒ *page 77*.

Please note:

In cooling mode, relative humidity in the interior is reduced. This prevents the windows from fogging up. When outside temperatures are low (temperatures below freezing), the air conditioning (compressor) switches off automatically - air in the vehicle interior is not dehumidified.







When relative humidity and temperatures outside are high, **condensate** can drip from the air conditioning evaporator and form a pool of water under the vehicle. This is normal and not an indication of a leak!

When outside temperatures are low, the fan does not switch to a higher speed until the coolant has reached an adequate temperature, with the exception of the defrost setting.

When accelerating at wide-open throttle, the air conditioning compressor is temporarily switched off to maintain full engine power.

In order to ensure engine cooling under extreme engine loads, the compressor is switched off if coolant temperatures climb too high.

Functions are set by turning the rotary knob or switched on and off by tapping the buttons. The LED in the buttons illuminates when the function is active.

Button(s)	Meaning	Page
Rotary knob ①	Temperature selection	⇒ page 75
Rotary knob ② 	Switch air conditioning on/off Fan	⇒ page 76
Rotary knob ③	Air distribution	⇒ page 76
	Defrost	⇒ page 77
	Rear window defogger	⇒ page 78
	Heated seat* driver/passenger side	⇒ page 79
	Recirculation	⇒ page 77
	Switch on cooling system	⇒ page 78

Pollutant filter

The pollutant filter (particle filter) ensures that contaminants in the outside air (such as dust or pollen) are greatly reduced or stopped. The air is also filtered in recirculation mode.

The pollutant filter element must be changed according to the intervals specified in the maintenance schedule so that the air conditioning system's performance is not adversely affected.

If the filter's effectiveness is weakened by driving the vehicle in areas with heavily polluted outside air, the filter element should also be changed between the listed services.

WARNING

For safety reasons, it is important that all windows are free of ice, snow, and condensation. Only then is good visibility ensured. Please familiarize yourself with the correct operation of the air conditioning and how to dehumidify/defrost the windows.

Note

- If you suspect that the climate controls have been damaged, switch the system off to avoid damaging it, and have it inspected by an authorized Audi dealer.
- Audi climate control system repairs require special expertise and the proper tools. You should contact an authorized Audi dealer in the event of malfunctions.

Tips

- To avoid adversely affecting heating and cooling performance and to prevent condensation on the windows, the air intake in front of the windshield must be free of ice, snow, and leaves.
- Climate control works most effectively if the windows are closed. However, if the interior of a parked vehicle is extremely hot from the sun's rays, briefly opening the windows can speed up the cooling process. ■

Setting temperature

- Turn the rotary knob ① ⇒ page 74, fig. 63 to the desired temperature setting.

To set a lower temperature, turn the rotary knob to the left. To set a higher temperature, turn the rotary knob to the right. There are additional intermediate settings available to adjust the temperature as needed. ■

Switching climate control on and off

Switching the climate control system on and off

- Turn the knob ② ⇒ *page 74, fig. 63* to the right to switch climate control on. The LED next to the word OFF goes out.
- Turn the knob ② ⇒ *page 74, fig. 63* to the left to switch the climate control system off. The LED next to the word OFF comes on.

Setting fan speed

- Turn the knob ② ⇒ *page 74, fig. 63* to the setting you want to adjust fan speed (air quantity).

If the difference between the desired temperature set by you and the vehicle's interior temperature is too great, the fan speed will change automatically. This is done so that the desired temperature setting is reached as quickly as possible.

Tips

If the difference between the desired temperature you have set and the vehicle's interior temperature is too high, the fan speed will change automatically. This is done so that the desired temperature setting is reached as quickly as possible. ■

Air distribution

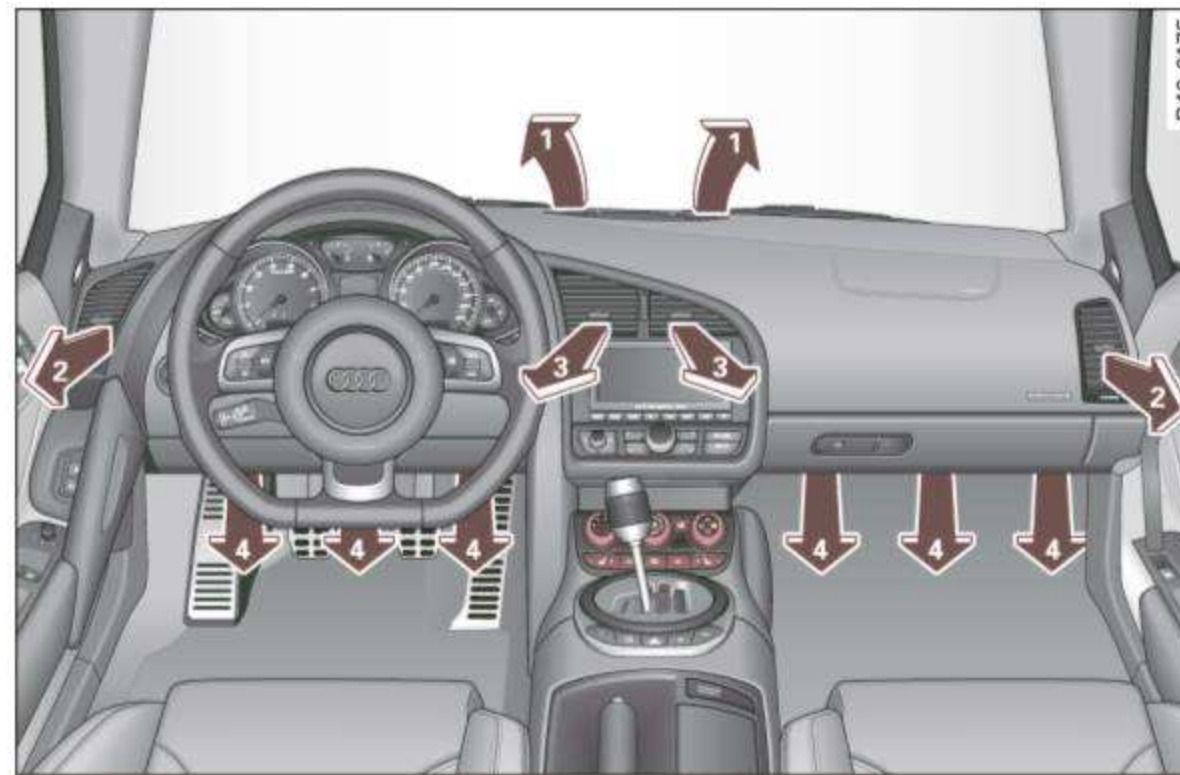











Fig. 64 Instrument panel: Location of air vents

- Turn the rotary knob ③ ⇒ *page 74, fig. 63* to the desired setting.
- To open and close the outlets, turn the adjusting ring.
- To adjust the direction of the airflow from the outlet, move the tab in the center of the outlet in the desired direction. The direction of the air delivered from the vents can be adjusted horizontally and vertically.



Air distribution:

- In setting , air flows only to the windows, vents ① and ② are open. To defrost the driver and front passenger side windows most effectively, the vents ② should be directed toward the side windows.

- In setting , air flows only to the driver/passenger, vents  and  are open.
- In setting , air flows only to the footwell, vents  are open.
- In setting , air flows only to the windows and the footwell, vents ,  and  are open.



There are additional combinations (through intermediate settings) available to adjust air distribution as needed.

Tips

If the climate controls are running in cooling mode, air should flow mainly from vents  and . To achieve sufficient cooling, you should never close these vents completely. ■

Defrost

The windshield and side windows are defrosted or cleared of condensation as quickly as possible.

- To turn on the defogger/defroster, press the  button ⇒ *page 74, fig. 63.*
- To turn the defogger/defroster off, press the  button again, or the **AUTO** button.

Temperature is controlled automatically. The maximum amount of air flows mainly from vents 1 ⇒ *page 76.*

A small amount of air flows from vents 2 - if they are open ⇒ *page 76.*

Pressing the  button switches off recirculation mode. ■

Automatic operation **AUTO**

Standard operating mode at all times of the year.

Turning on automatic operation



- Set the temperature you want.
- Press the **AUTO** button ⇒ *page 74, fig. 63.*

Automatic operation ensures constant temperatures in the interior and dehumidifies the air inside the vehicle. Air temperature, volume, and distribution are controlled automatically to reach or maintain the desired interior temperature as quickly as possible. Fluctuations in exterior temperature and the effects of temperature from the position of the sun are compensated for automatically. ■

Manual air recirculation mode

The recirculation mode prevents polluted outside air from entering the vehicle interior.

Switching on air recirculation

- Press the button  ⇒ *page 74, fig. 63,* ⇒ .

Switching off air recirculation

- Press the button  again, or
- Press the **AUTO** button, or
- Press the  button.

In recirculation mode, air is drawn from the vehicle interior, filtered, and recirculated. We recommend that you select recirculation mode *briefly* ⇒  under the following conditions:

When driving through a tunnel or in a traffic jam so that exhaust fumes and odors cannot enter the vehicle interior. ►

 **WARNING**

You should not use the recirculation mode for an extended period since no fresh air is drawn in, and with the air conditioning switched off the windows can fog up - this increases the risk of an accident! ■

A/C operation

Switching on A/C

- Press the  button ⇒ *page 74, fig. 63.*

Switching A/C off

- Press the  button again.

The cooling system is switched on during A/C operation - the heating and ventilation system is controlled automatically.

 **Tips**

If the LED in the switch stays on after A/C operation has been switched off (= switching the A/C off), there is a fault in an air conditioning component. Please consult an authorized Audi dealer when there is an operating problem. ■

Using the climate controls economically

Economical use of the climate controls helps to save fuel.

When climate control is working in cooling mode, engine performance is reduced and fuel consumption is affected. To keep the time the air conditioning is on as short as possible, you should do the following:

- If you would like to save fuel, switch the air conditioning off.
- If you open the windows while driving, switch the air conditioning off.
- If the vehicle is extremely hot due to the heat of the sun, briefly open doors and windows.



For the sake of the environment

When you save fuel, you reduce emissions from the vehicle. ■

Rear window defogger

The rear window defogger clears the rear window of condensation.

- Press the  button ⇒ *page 74, fig. 63* to turn the rear window defogger on and off.

The rear window defogger works only when the engine is running. The indicator light in the button illuminates when the rear window defogger is turned on.

The rear window defogger is switched off automatically after approx. 10 minutes.



For the sake of the environment

As soon as the rear window is clear, you should switch the rear window defogger off. The reduced power consumption has a beneficial effect on fuel consumption. ■

Applies to vehicles: with heated seats

Heated seats

The seat cushion and the seat back of the front seats can be heated electrically.

- Press the heated seats button  ⇒ *page 74, fig. 63* to set the level of heating desired.

The range of controls goes from 1 to 3. The heat setting selected is shown by LEDs above the button.

Note

To avoid damage to the heating elements in the seats, do not kneel on the seats or place heavy loads on a small area of the seat. ■

On the road

Steering

Adjusting the steering wheel column

The steering wheel position can be continuously adjusted in height and distance.

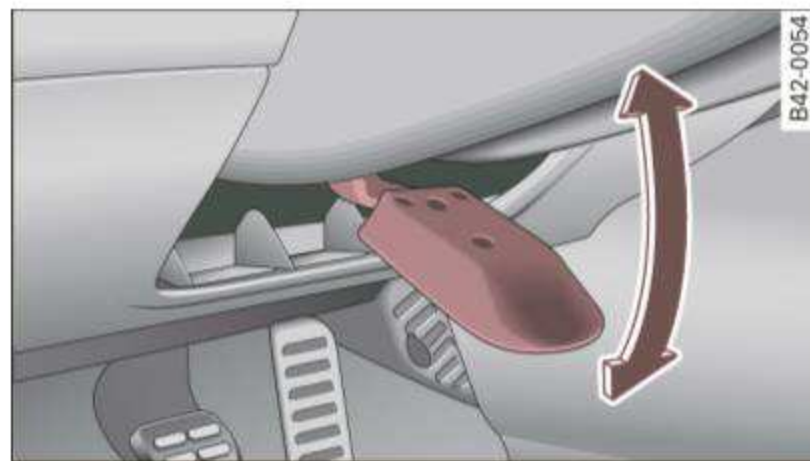

Fig. 65 Lever under the steering column

- Push the lever ⇒ fig. 65 down ⇒ ⚠.
- Move the steering wheel to the desired position.
- Push the lever against the steering column until it locks.

There must be at least 10 inches (25 cm) between your chest and the center of the steering wheel. If you cannot sit more than 10 inches (25 cm) from the steering wheel, see if adaptive equipment is available to help you reach the pedals and increase the distance from the steering wheel.

⚠ WARNING

Improper use of steering wheel adjustment and improper seating position can cause serious personal injury.

⚠ WARNING (continued)

- Adjust the steering wheel column only when the vehicle is not moving to prevent loss of vehicle control.
- Adjust the driver's seat or steering wheel so that there is a minimum of 10 inches (25 cm) between your chest and the steering wheel ⇒ *page 108, fig. 85*. If you cannot maintain this minimum distance, the airbag system cannot protect you properly.
- If physical limitations prevent you from sitting 10 inches (25 cm) or more from the steering wheel, check with your authorized Audi dealer to see if adaptive equipment is available.
- If the steering wheel is aligned with your face, the supplemental driver's airbag cannot provide as much protection in an accident. Always make sure that the steering wheel is aligned with your chest.
- Always hold the steering wheel with your hands at the 9 o'clock and 3 o'clock positions to reduce the risk of personal injury if the driver's airbag deploys.
- Never hold the steering wheel at the 12 o'clock position or with your hands inside the steering wheel rim or on the steering wheel hub. Holding the steering wheel the wrong way can cause serious injuries to the hands, arms and head if the driver's airbag deploys. ■

Ignition lock and ignition switch

Ignition lock

The ignition key starts or stops the engine.

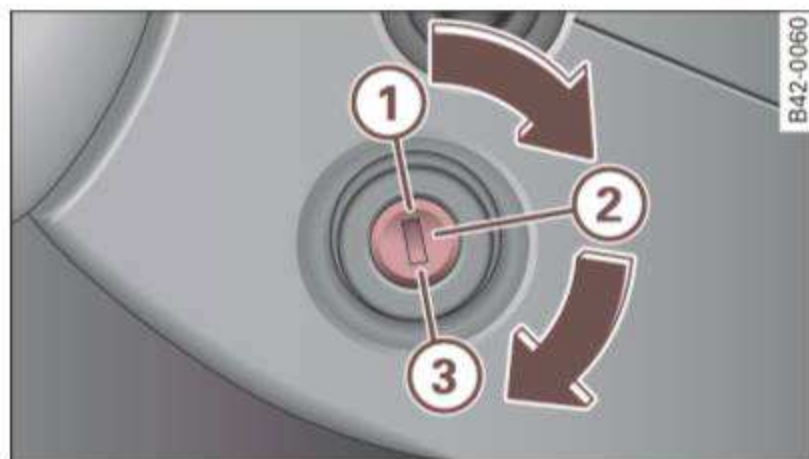

Fig. 66 Ignition lock positions

Ignition off ①

In position ⇒ fig. 66 ① both the ignition and engine are off, and the steering is locked.

To **lock the steering** after you have removed the ignition key, turn the steering wheel in either direction until you hear it lock into place. You should always lock the steering whenever you leave your vehicle. This makes vehicle theft even more difficult ⇒ ⚠.

Ignition on ②

After switching the ignition on, the needles move all the way up and then down.

If it is difficult to turn the key after you have inserted it into the ignition lock, turn the steering wheel back and forth. This will take the load off the steering lock mechanism and you will be able to turn the key freely and start the engine.

Starting the engine ③

In this position the engine starts. While the engine is starting, the power supply to the headlights and other electrical consumers is

temporarily interrupted to conserve battery power. After the engine has started, release the key and it will return to position ②.

Before the starter can be operated again the key must be turned back to position ①. The **non-repeat lock** prevents you from damaging the starter when the engine is running.

⚠ WARNING

- Never remove the key from the ignition lock while the vehicle is moving. The steering wheel will lock causing loss of control.
- If you have to leave your vehicle - even for just a minute - always remove the ignition key and take it with you. This is especially important if you are going to leave children behind in the vehicle. The children could start the engine or use other vehicle controls. Unsupervised use of vehicle controls (for example, power windows) can cause serious personal injuries.

i Tips

If the vehicle battery has been disconnected and then reconnected, then you must leave the key in position ② for about 5 seconds before you can start the engine. ■

Starting the engine

The engine can only be started with your original Audi key.

On vehicles with R tronic, the engine can be started in the neutral position N and in each gear (1 - 6 and R).

- Set the parking brake ⇒ ⚠.
- On vehicles with manual transmission, fully depress the clutch pedal.
- Press and hold the brake pedal. ▶

- Turn the ignition key to position ③ ⇒ *page 81, fig. 66* - do not depress the gas pedal when starting the engine.
- Let go of the key as soon as the engine starts - the starter must not continue to run. On vehicles with R tronic, select gear position N.

A cold engine may at first be loud after it has been started. This is due to the hydraulic valves building up the oil pressure. This is normal and no need for concern.

If the engine does not start immediately, stop trying after 10 seconds and then try to restart the engine about 30 seconds later.

WARNING

- **Never start or let the engine run in a confined or enclosed area. Exhaust fumes from the engine contain carbon monoxide, a colorless and odorless gas. Carbon monoxide can be fatal if inhaled.**
- **Never leave the engine idling unattended. An unattended vehicle with a running engine poses a danger of personal injury or theft.**
- **With the engine running and a gear engaged, you have to hold the vehicle with the foot brake.**

Note

- Avoid high engine speeds, fast acceleration or heavy engine loads while the engine is still cold. This could damage the engine.
- The engine cannot be started by pushing or towing the vehicle.



For the sake of the environment

To avoid unnecessary engine wear and to reduce exhaust emissions, do not let your vehicle stand and warm up. Be ready to drive off immediately after starting your vehicle. ■

Stopping the engine

On vehicles with R tronic, the engine can be turned off in the neutral position N and in each gear (1 - 6 and R).

- Turn the ignition key to position ① ⇒ *page 81, fig. 66*.

WARNING

- **Never turn off the engine until the vehicle has come to a complete stop.**
- **The brake booster and servotronic only work when the engine is running. With the ignition turned off, you have to apply more force when steering or braking. Since you cannot steer and stop normally, this can lead to accidents and serious injuries.**

Note

- If the engine has been under heavy load for an extended period of time, heat builds up in the engine compartment after the engine is switched off - there is a risk of damaging the engine. Allow the engine to continue to run at idle for a short time or drive until it has cooled down before you turn it off ⇒ *page 170*.
- If the engine has been under heavy load for an extended period of time, it can become extremely hot. You should not park your vehicle over easily combustible objects or areas (e.g. grass or leaves). There is a risk of starting a fire.

Tips

After the engine has been switched off, the radiator fan can continue to run for up to 10 minutes - even with the ignition switched off. It can also switch on again after some time if the coolant temperature rises as the result of heat buildup or if the engine compartment is heated by the sun's rays and the engine is hot. ■

Parking brake

Parking brake

When the parking brake is set, it prevents the vehicle from rolling away unintentionally.

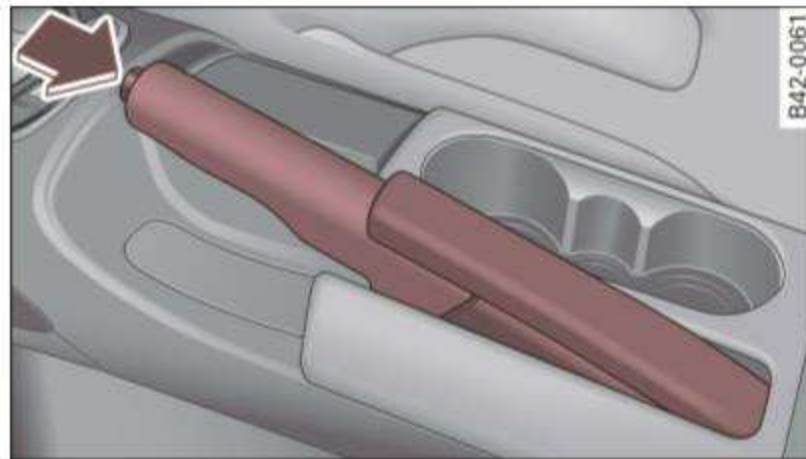

Fig. 67 Center console: Parking brake set

Setting the parking brake

- Pull the parking brake lever all the way up.

Releasing the parking brake

- Pull the parking brake lever up slightly *and* press the release button at the same time ⇒ fig. 67 - arrow -.
- Keep the release button pressed and lower the parking brake ⇒ ⚠.

If you should drive off with the parking brake still set, a warning tone will sound and the following message will appear in the instrument cluster to remind you to release the parking brake:

Parking brake is applied

The parking brake warning comes on only after you have driven for longer than 3 seconds and faster than 3 mph (5 km/h).

The parking brake warning light **Brake** (USA)/⚠ (CDN) illuminates when the parking brake is set and you switch on the ignition.

⚠ WARNING

Always release the parking brake completely. A partially engaged brake will overheat the rear brakes, reduce their effectiveness and cause excessive wear. This could lead to brake failure and an accident.

⚠ Note

Only after the vehicle has come to complete stop, should you firmly set the parking brake and move the gearshift lever into a gear. ■

Parking

To prevent a parked vehicle from rolling away, there are a few things you should do.

- Stop the vehicle using the brake pedal.
- Set the parking brake firmly.
- Switch off the engine.
- Engage a gear ⇒ ⚠.

What else you should do when parking your vehicle on an incline or decline

Turn the steering wheel so that if the vehicle should start to roll, it will roll into the curb.

⚠ WARNING

This is how you can reduce the risk of injury when leaving your vehicle. ▶

 WARNING (continued)

- Never park the vehicle where it can come in contact with dry grass, spilled fuel or any other flammable materials.
- Never allow anyone - especially small children - to remain in the vehicle when it is locked. Locked doors make it more difficult for rescuers to access the passenger compartment in the event of an emergency. **Danger to life!**
- Never leave children unsupervised in the vehicle. Children could release the parking brake or move the gearshift lever out of gear. The vehicle could start to roll away and cause an accident.
- No matter what the season is, the temperature in a parked vehicle can reach dangerous levels. ■

Applies to vehicles: with hill hold assist

Starting on hills

Hill hold assist makes it easier to start on hills.

The system is activated when the brake pedal is depressed **for a few seconds**.

After releasing the brake pedal, the brake power is held for a *brief moment* to prevent the vehicle from rolling back when starting. During this time, you can easily begin to move your vehicle.

 WARNING

- If you did not begin moving immediately after releasing the brake pedal, the vehicle could begin to roll backward under certain circumstances. Depress the brake pedal immediately or engage the parking brake.
- If the engine stalls, depress the brake pedal immediately or engage the parking brake.

 WARNING (continued)

- To prevent the vehicle from rolling back unintentionally when starting in stop-and-go traffic, keep the brake pedal depressed for a few seconds before driving off.

 Tips

You can find out if your vehicle is equipped with “Hill hold assist” at an authorized Audi dealer. ■

Cruise control

Introduction

The cruise control system keeps the speed constant.

The cruise control system makes it possible to drive at a constant speed over 20 mph (US model) or 30 km/h (Canadian model). This is true only to the extent that engine power or engine braking effect allow. Using the system takes the strain off the “gas pedal foot” – especially on long trips.

In the control mode, the indicator light in the instrument cluster is lit **CRUISE** (US model) /  (Canadian model).

The cruise control system automatically **switches itself off immediately** under the following conditions:

- Pressing the brake pedal.
- Pressing the clutch pedal.

 WARNING

- Always pay attention to traffic even when the cruise control system is switched on. You are always responsible for your speed and the distance between your vehicle and other vehicles. ▶

⚠ WARNING (continued)

- For safety reasons, the cruise control system should not be used in the city, in stop-and-go traffic, on twisting roads and when road conditions are poor (such as ice, fog, gravel, heavy rain and hydroplaning) - risk of accident.
- Turn off the cruise control system temporarily when entering turn lanes, highway exit lanes or in construction zones.
- Please note that inadvertently "resting" your foot on the accelerator pedal causes the cruise control system not to brake. This is because the cruise control system is overridden by the driver's acceleration.

! Note

On manual transmission vehicles: If you shift into neutral with the cruise control system switched on, always depress the clutch pedal! Otherwise the engine will race and could be damaged as a result.

i Tips

When driving on steep downward grades, the cruise control system cannot keep the speed constant. The vehicle's own weight increases the speed. Shift into a lower gear in plenty of time or brake the vehicle with the foot brake. ■

Saving the speed

The desired speed must be saved.

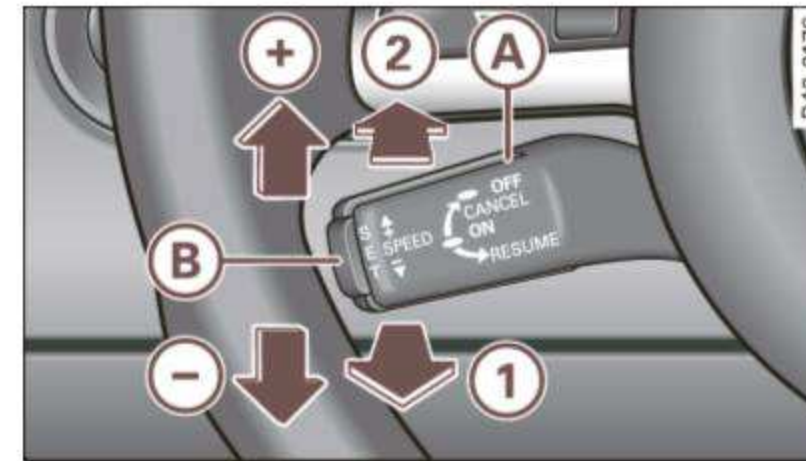

Fig. 68 Cruise control system controls

- Drive at the speed you wish to set.
- Pull the lever (A) to position (1) ⇒ fig. 68 to switch the system on.
- Briefly press button (B).

After the button (B) is released, the current vehicle speed is stored and maintained, i. e. you are driving in control mode. ■

Changing speed

The desired speed can be changed.

Faster

- Press lever (A) up towards the (+) ⇒ fig. 68.
- Release the lever to store the current speed.

Slower

- Press lever (A) down towards the (-) ⇒ fig. 68.
- Release the lever to store the current speed.

You can also increase your speed by pressing the accelerator pedal. After you release the accelerator pedal, the system automatically adjusts back down to the speed you previously set.

However, if you exceed this speed by 5 mph (10 km/h) for longer than 5 minutes, the stored speed will be deleted. You will have to resave it.

Briefly pressing lever **(A)**

The desired speed is increased by about 2 mph (2 km/h) by briefly pressing lever **(A)** upwards towards \Rightarrow fig. 68 **(+)**.

The desired speed is decreased by about 2 mph (2 km/h) by briefly pressing lever **(A)** downwards towards \Rightarrow fig. 68 **(-)**. ■

Switching control mode off temporarily

- Step on the brake pedal, or
- Depress the clutch pedal all the way, or
- Press the lever **(A)** towards **(2)** (not latched) \Rightarrow page 85, fig. 68.

When the system is turned off temporarily, the speed stored at the time is retained.

To resume the stored speed, release the brake or clutch pedal and pull the lever **(A)** to position **(1)**.

If no desired speed was stored when the system was temporarily switched off, you can store a new desired speed as follows: Drive at the desired speed and briefly press button \Rightarrow page 85, fig. 68 **(B)** (SET).

WARNING

You should only return to the saved speed if it is not too fast for the current traffic conditions - risk of an accident! ■

Deactivating

- Press lever **(A)** into position **(2)** (latched) \Rightarrow page 85, fig. 68.

The saved speed value is deleted when the ignition is switched off.

Tips

Switch the cruise control system off completely at the end of each trip. When you start the next trip, the desired speed can be set simply from the basic setting \Rightarrow page 85. ■

Applies to vehicles: with Audi magnetic ride

Audi magnetic ride

Damping can be adjusted to the driver's preference and it adapts automatically to the current driving situation.

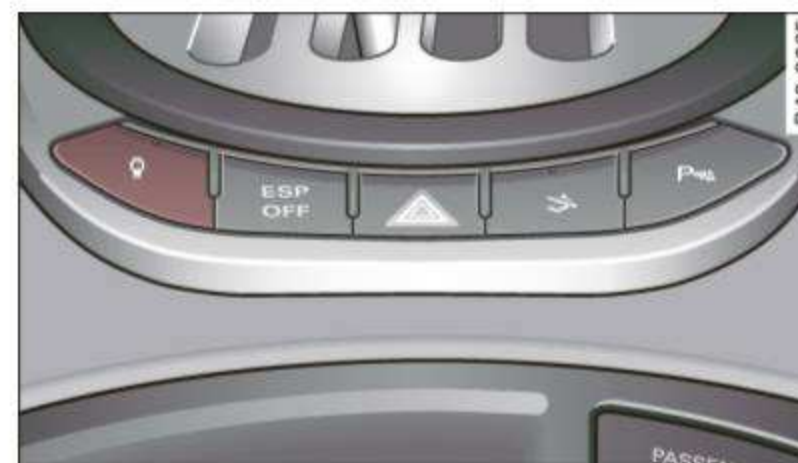

Fig. 69 Center console: Switch for Audi magnetic ride

- Press the switch \Rightarrow fig. 69 to turn sport setting on or off.

Audi magnetic ride is an electronically controlled damping system. This chassis system assists the driver by adapting to the particular situation through imperceptible control processes. The **damping** provides individual modulation of damping forces. For example, ►

with damping characteristics set to provide greater comfort, damping is set somewhat harder for a brief period only as required, when rounding a curve and when braking.

Standard setting

Select the standard setting if you prefer a suspension setting emphasizing comfort.

Sport setting

Select the sport setting if you prefer a sporty suspension setting. The LED in the switch  comes on to indicate sport setting.



Tips

The warning/indicator light  in the instrument cluster comes on in the event of a malfunction. Drive to the closest authorized Audi dealer as soon as possible and have the malfunction repaired. ■

Automated manual transmission

Applies to vehicles: with R tronic

Description

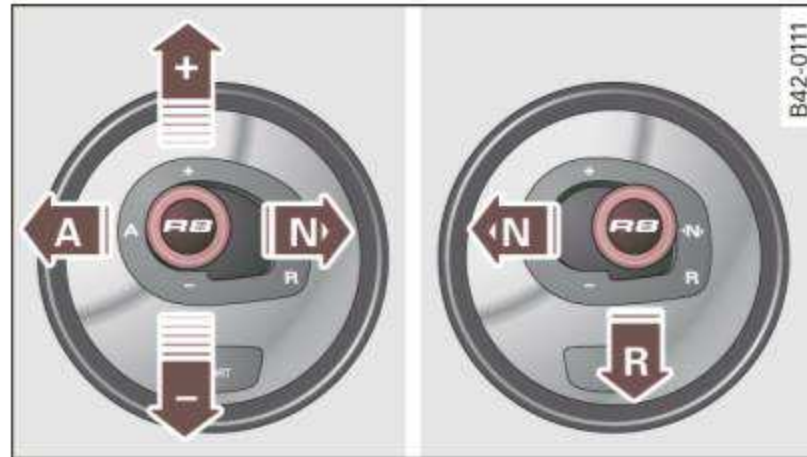

Fig. 70 Shift pattern



Fig. 71 Display: Gears engaged

R tronic is an automated manual transmission in which the function of the clutch and shifting is controlled by an electronic system.

The gears are engaged manually, similarly to a manual transmission. The gears can also be shifted automatically. The engine can be started and switched off in all gears.

The selected mode of operation, the gear engaged and the sport function are shown in the Driver Information System display ⇒ fig. 71.

M - Manual operation

In this operating mode, you shift the forward gears using the selector lever ⇒ page 89 or the shift paddles on the multifunction steering wheel ⇒ page 91.

A - Automatic operation

In this operating mode, the forward gears are shifted up or down depending on engine load and vehicle speed ⇒ page 90.

R - Reverse gear

Reverse gear must only be engaged when the vehicle is *stationary* and the engine is running at idle speed ⇒ ⚠.

To engage reverse gear, you have to press the brake pedal, move the selector lever to the right and tip it towards R. In reverse gear, the backup lights illuminate when the ignition is on.

N - Neutral

To engage neutral, you have to move the selector lever to the left or to the right. If reverse gear is engaged, move the selector lever to the left. If a forward gear is engaged, move the selector lever to the right.

Sport function

The sport function is switched on by pressing the **SPORT** button. The engine's power reserves can be used fully by upshifts later. Shift time is decreased and accelerator pedal response is improved. In addition, in manual operation the engine does **not** shift automatically into the next gear before it has reached the maximum permissible engine speed. In automatic operation, upshifting continues automatically. ▶

WARNING

- If a gear is engaged when the vehicle is stationary, the accelerator must not be pressed inadvertently under any circumstances. Otherwise the vehicle will immediately start to move - sometimes even if the parking brake is firmly applied.
- Before you or other persons open the engine compartment lid and work on a running engine, select neutral position N and firmly apply the handbrake. Follow the warning notes.

Tips



If you accidentally shifted into N while driving, you can engage a gear in the normal way using the selector lever or the shift paddles. ■

Applies to vehicles: with R tronic



Manual operation

R tronic allows the driver to shift gears manually.

Starting from a stop

- Press and hold the brake pedal.
- Move the selector lever to the left.
- Tap the selector lever forward .
- Release the brake pedal and accelerate \Rightarrow .

Shifting

- To shift up, tap the selector lever forward .
- To shift down, tap the selector lever to the rear .

Stopping temporarily

- Prevent the vehicle from moving by using the foot brake, e.g. at traffic signals.
- Do not accelerate. If you do not press either the brake pedal or the accelerator pedal for some time when stationary, neutral position N is engaged automatically and a chime sounds.

Parking

- Press and hold the brake pedal \Rightarrow .
- Apply the hand brake firmly.
- Engage a gear.
- Switch the ignition off.

Stopping on an incline

- Always keep the vehicle stationary using the foot brake to prevent it from “rolling back” \Rightarrow . Do **not** try to prevent the vehicle from “rolling back” when a gear is engaged by increasing engine speed.
- Apply the hand brake firmly.

Starting on a hill

- With a gear engaged, remove your foot from the brake, accelerate and slowly release the hand brake.

When accelerating, R tronic shifts into the next gear in gears 1, 2, 3, 4 and 5 shortly before the maximum permissible engine speed is reached. Exception: You have activated the sport function \Rightarrow page 88.

If you have selected a lower gear than the current one, R tronic will shift down only when the engine will not be over-revved. ►

You can switch to automatic operation at any time ⇒ *page 90*.

WARNING

- **Never leave your vehicle with the engine running while in gear. If you must leave your vehicle with the engine running, set the parking brake firmly and engage neutral N.**
- **With the engine running and a gear engaged, you have to hold the vehicle with the foot brake.**
- **Do not accelerate when you shift gears with the vehicle stationary and the engine running.**
- **If you must stop on an incline, always hold the vehicle in place with the foot brake to prevent it from rolling back. Never hold the vehicle on an incline with a slipping clutch. The clutch is automatically opened when it becomes too hot from the overload. Before the clutch opens, overload is signaled by the vehicle bucking and a warning message in the Driver Information Display.**
- **Before driving down a steep slope, reduce your speed and shift into a lower gear with R tronic.**
- **Do not ride the brakes or apply the brake pedal too often or too long. Constant braking causes the brakes to overheat and substantially reduces braking performance, increases braking distance or causes complete failure of the brake system. ■**

Applies to vehicles: with R tronic

Automatic operation

The forward gears are shifted up or down automatically.

Starting from a stop

- Press and hold the brake pedal.
- Tap the selector lever towards A.

- Release the brake pedal and accelerate ⇒  in “Manual operation” on *page 89*.

Under certain circumstances (driving in the mountains for example), it can be beneficial to switch temporarily to the manual shift program ⇒ *page 89* in order to adjust the gear ratios to driving conditions *manually*. ■

Applies to vehicles: with R tronic

Kick-down

When you depress the accelerator pedal beyond the resistance point, R tronic downshifts into a lower gear, depending on vehicle speed and engine rpm. The upshift into the next higher gear takes place once the maximum specified engine speed is reached. Exception: You have activated the sport function.

WARNING

Please note that the drive wheels can spin if kick-down is used on a smooth slippery road - there is a risk of skidding. ■

Applies to vehicles: with R tronic

Launch Control Program

The Launch Control Program enables maximum acceleration.

- With the engine running, press the ESP switch once. The ESP warning/indicator light  illuminates in the Driver Information System display.
- Press the brake pedal with your left foot and hold it down.

- Engage a gear.
- Press the **SPORT** button.
- Press the accelerator pedal with your right foot until the engine has reached a constant speed.
- Remove your left foot from the brake ⇒ .

WARNING

- Always adapt your driving to the traffic flow.
- Only use Launch Control when road and traffic conditions allow it and other drivers will not be endangered or annoyed by your driving and the vehicle's acceleration.
- Please note that the driving wheels can spin and the vehicle can break away when ESP is switched off, especially when the road is slippery.
- Once the starting procedure is complete, you should switch ESP on again by pressing the ESP switch.

Tips

When accelerating using the Launch Control program, all vehicle parts are subject to heavy loads. This can result in increased wear. ■

Applies to vehicles: with R tronic

Steering wheel with shift paddles

The shift paddles allow you to select gears manually at the steering wheel.

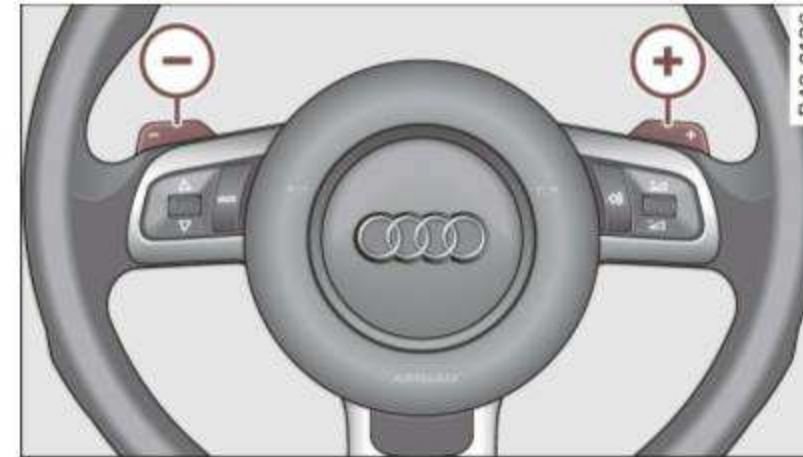



Fig. 72 Sport steering wheel: Shift paddles

- To shift down, press the paddle on the left .
- To shift up, press the paddle on the right .

Of course, you can continue to use the manual shift program with the selector lever in the center console. ■

Applies to vehicles: with R tronic

Emergency program

In the event of a system malfunction, there is an emergency program.

In the event of a system malfunction, R tronic switches to emergency operation mode. This is indicated by a red bar lighting up or flashing in the Driver Information System display.

An illuminated bar signals that you can continue driving the vehicle.

A flashing bar signals a serious system malfunction:

- The program shifts only into certain gears. ►

- The engine may stall.
- It is not possible to restart the engine if it has been switched off.
- Continuing to drive could result in subsequent damage.

 **Note**

If R tronic has switched to emergency operation mode, you should have the malfunction corrected as soon as possible. ■

Parking system

General information

Depending on your vehicle's equipment, various parking aids will help you when parking and maneuvering.

The **acoustic park assist** uses acoustic signals to warn you about obstacles detected in front of or behind the vehicle ⇒ *page 93*.

The **advanced parking system** has a rearview camera that shows an image of the area behind the vehicle in the navigation system display. This image helps you when parallel parking or reverse parking ⇒ *page 94*. The acoustic park assist also sends out warning signals. ■

Acoustic park assist

Applies to vehicles: with acoustic park assist

Description

Sensors are located in the front and rear bumpers. The sensors send out an audible signal to warn you when they detect an obstacle. The range at which the sensors begin to measure is **approximately**:

To the side	0.60 m
Center rear	1.50 m
Center front	1.00 m

The closer you come to an obstacle, the more frequently the acoustic signals will sound. A continuous alarm sounds when you are 0.35 m away when driving in reverse and when you are 0.30 m away when you are driving forward. This means you should stop driving!

You can change the volume and pitch of the signals ⇒ *page 26*.

Tips

The sensors must be kept clean and free of snow and ice for the park assist to operate. Please follow the additional notes on ⇒ *page 94*. ■

Applies to vehicles: with acoustic park assist

Switching the system On/Off

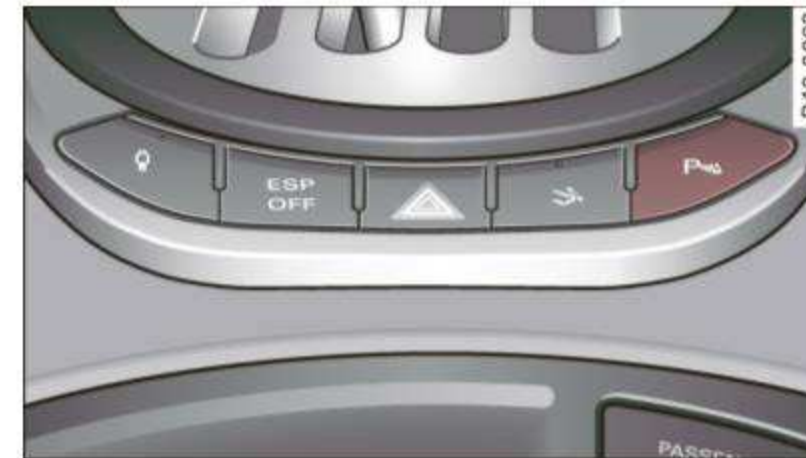



Fig. 73 Section of the center console: Park assist switch

The park assist is activated automatically when reverse gear is engaged. When you park the vehicle forwards or wish to drive up to an obstacle, you need to activate the parking aid manually.

Activating

- Engage the reverse gear, or
- Press the  switch in the center console ⇒ *fig. 73* to activate the park assist manually. The LED in the switch lights up. ▶

Deactivating

- Drive forward faster than 15 km/h, or
- Turn the engine off, or
- Press the P_{PA} switch in the center console.

WARNING

- Sensors have blind spots in which objects cannot be detected. Pay special attention to small children and animals because the sensors cannot always detect them.
- The park assist cannot replace the driver's attention. The driver alone is responsible for parking and similar driving maneuvers.
- Always keep your eyes on the vehicle's surroundings, using the rearview mirror as well.

Note

Low obstacles already signaled by a warning can disappear from the system's detection range as they are approached and will not continue to be signaled. Objects such as barrier chains, trailer draw bars, narrow painted vertical poles or fences may not be detected by the system, posing risk of damage.

Tips

Your vehicle has low ground clearance. To prevent damage to vehicle, warning signals will warn you in advance before you start driving on inclines (such as in a parking structure or garage). ■

Applies to vehicles: with acoustic park assist

Error Messages

There is an error in the system if the LED on the P_{PA} switch is blinking and you hear a continuous alarm for a few seconds after activating

the acoustic park assist. You will be alerted of this system error after:

- each manual activation of the system using the P_{PA} switch*, or
- the first time you put the vehicle in reverse while the ignition is running, or
- an error is detected during operation.

Tips

When the system reports an error, contact an authorized Audi dealer or other qualified workshop fix the system error. ■

Advanced parking system

Applies to vehicles: with advanced parking system

Introduction

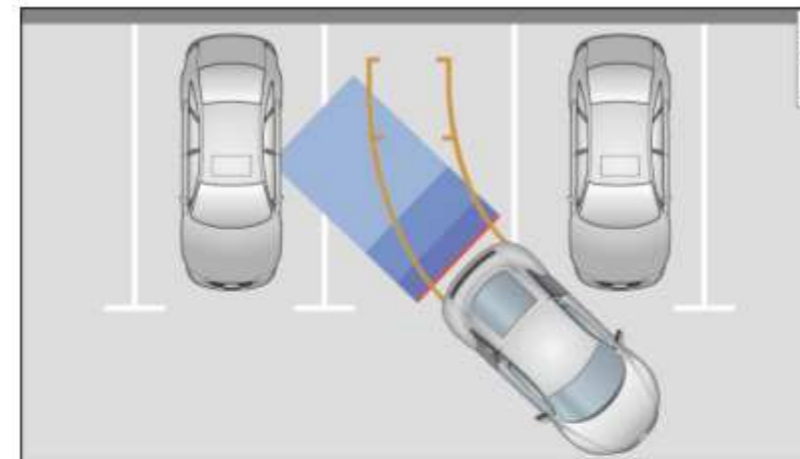

Fig. 74 View from top:
Parking mode 1

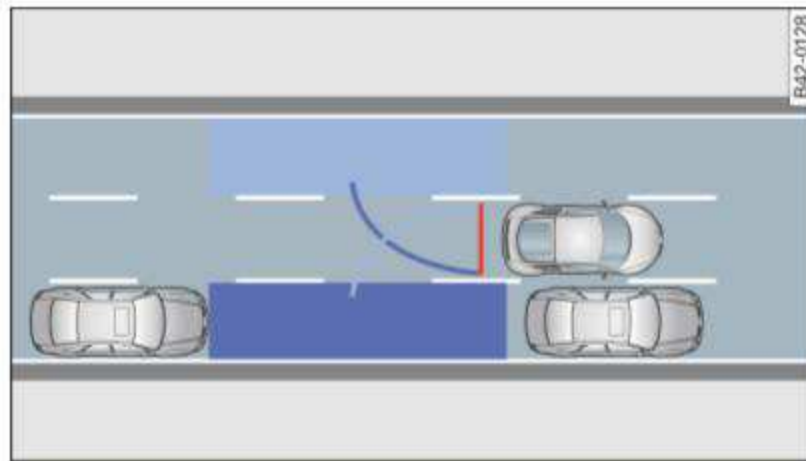

Fig. 75 View from top:
Parking mode 2

Vehicles with the advanced parking system are equipped with a rearview camera in addition to the acoustic park assist ⇒ *page 93*. You can choose between two parking modes to assist you with parking. For example, you can use parking mode 1 when parking in a garage or parking space ⇒ *page 94*, fig. 74. When you want to parallel park, select parking mode 2 ⇒ fig. 75. ■

Applies to vehicles: with advanced parking system

Description

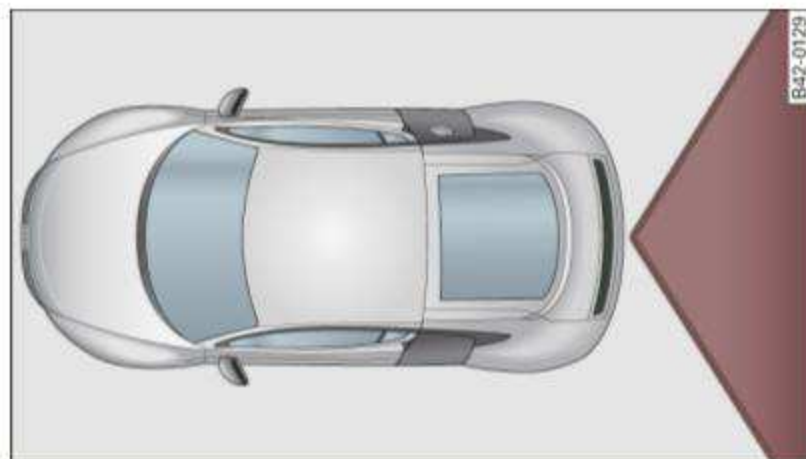

Fig. 76 View from top:
Rearview camera
coverage area

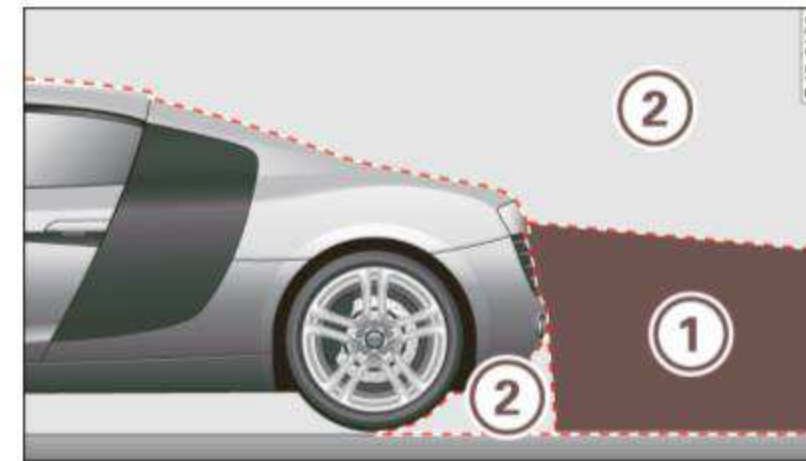

Fig. 77 Side view:
Rearview camera
coverage area

The rearview camera shows you the area behind your vehicle in the navigation system display. This area roughly corresponds to the area in ⇒ fig. 76 and ① ⇒ fig. 77. Orientation lines and colored surfaces are projected in the area shown, which can help you with parking and maneuvering. Objects that are located in an area that is not captured by the camera ② ⇒ fig. 77 and that are closer to the bumper will not appear on the navigation system display. ■

Applies to vehicles: with advanced parking system

General information

We recommend that you practice parking with the rearview camera in a traffic-free location or parking lot to become familiar with the system, the orientation lines, and their function. There should be sufficient light and good weather conditions when doing so.

Objects or vehicles appear closer or farther away in the navigation system if:

- you are driving in reverse gear from a level surface onto an incline, or a downward slope,
- you are driving in reverse gear toward protruding objects.

The accuracy of the orientation lines and blue surfaces diminishes if:

- the rearview camera does not provide a reliable image, for example, in poor visibility conditions or if the lens is dirty,
- the image on the screen is not visible due to sun glare and reflection.

Caring for the rearview camera lens

The rearview camera is located in the center of the vehicle above the rear license plate bracket.

- Dampen the lens with a household alcohol-based glass cleaner, and clean the lens with a dry cloth.
- Remove snow with a hand brush.
- Remove ice, preferably with de-icing spray ⇒ .

WARNING

- **The rearview camera cannot replace the driver's attention. The driver alone is responsible for parking and similar driving maneuvers.**
- **Always keep your eyes on the vehicle's surroundings, using the rearview mirror as well.**
- **Do not allow yourself to be distracted from traffic by the rearview camera pictures in the navigation system display.**
- **If the position and the installation angle of the camera has changed, for example, after a rear end collision, do not continue to use the system for safety reasons. Have it checked by an authorized Audi dealer or other qualified workshop.**

Note

- Low obstacles already signaled by a warning can disappear from the system's detection range as they are approached and will not continue to be signaled. Objects such as barrier chains, trailer draw bars, narrow painted vertical poles or fences may not be detected by the system, posing risk of damage.

- Never use warm or hot water to remove snow or ice from the rearview camera lens because the lens could crack.
- Never use products that are abrasive when cleaning the lens.

Tips

In order for the rearview camera to function properly, the camera lens must be kept clean and free of snow and ice. ■



Applies to vehicles: with advanced parking system

Switching the camera On/Off

The rearview camera switches on automatically together with the acoustic park assist when you put the vehicle in reverse.

Requirement: The navigation system and navigation system display must be switched on.

Activating

- Engage the reverse gear, or
- Press the  switch in the center console ⇒ *page 93, fig. 73* to activate the park assist manually. The LED in the switch lights up. Parking mode 1 appears ⇒ .

Deactivating

- Drive forward faster than 15 km/h, or
- Turn the engine off, or
- Press the  switch in the center console. ▶

! WARNING

- The navigation system display cannot show, or cannot adequately show, certain objects (such as small posts or grating), recesses in the ground and protruding parts on another car.
- Only use the rearview camera to assist you if it shows a good, clear picture. For example, the image may be affected by the sun shining into the lens, dirt on the lens or if there is a defect. ■

Applies to vehicles: with advanced parking system

Reverse parking

Use parking mode 1 to help you when parking in a garage or parking spot.

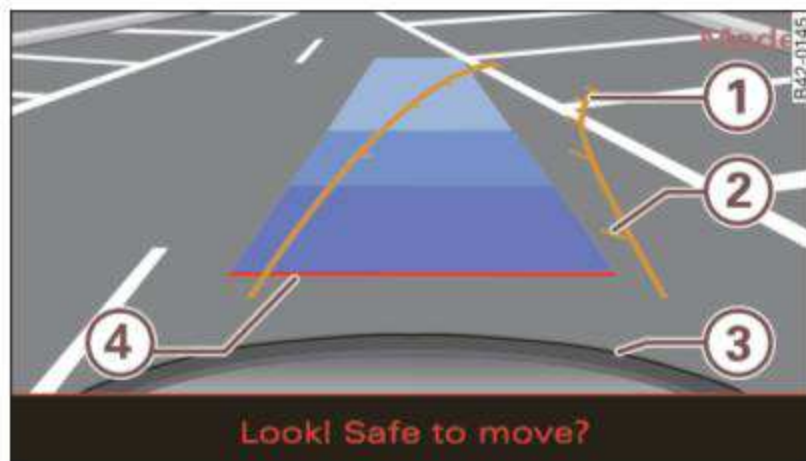

Fig. 78 Navigation system display: Aiming at a parking spot

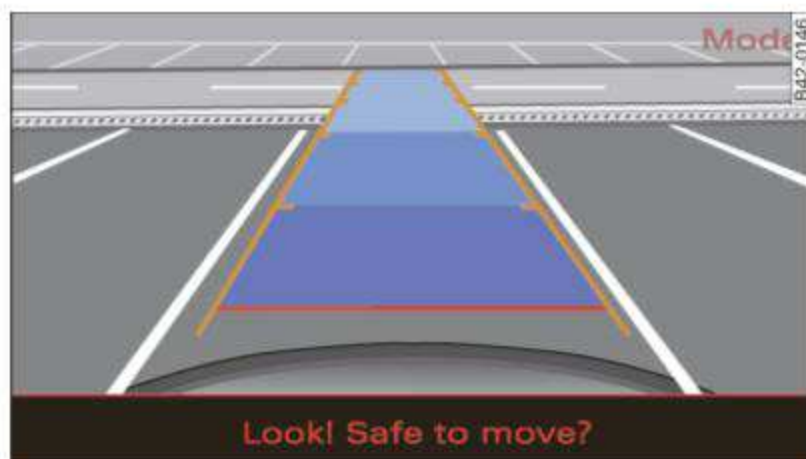

Fig. 79 Navigation system display: Aligning the vehicle

Requirement: The parking system is on and parking mode 1 ⇒ fig. 78 is shown in the navigation system display ⇒ page 96.

- Turn the steering wheel until the orange orientation lines ① appear in the parking spot. Use the markings ② to help you estimate the distance from an obstacle. Each marking corresponds to 1 meter.
- While driving in reverse gear, adjust the steering wheel angle to fit the parking space with the aid of the orange orientation lines ⇒ !. ③ marks the rear bumper. You should stop driving in reverse when the red orientation line ④ meets an object, at the latest ⇒ !.
- Align your vehicle to correspond with the blue area ⇒ fig. 79. The blue area represents an extension of the vehicle's outline by approximately 5 m to the rear. The distance of the differently shaded areas to the vehicle are approximately 1, 2 and 5 meters.

! WARNING

- The rearview camera does not show the entire area behind the vehicle ⇒ page 95, fig. 77. Watch out especially for small children and animals because the rearview camera cannot always detect them.
- Please note that objects not touching the ground can appear to be farther away than they really are (for example, the bumper of a vehicle or the rear of a truck). In this case, you should not use the orientation lines to help with parking.
- Maintain plenty of distance from obstacles so that your outside mirror or a corner of your vehicle does not come into contact with them.

! Note

The navigation system display shows the direction in which the rear of the vehicle is traveling based on the steering wheel angle. The vehicle front swings out more than the vehicle rear. ■

Applies to vehicles: with advanced parking system

Parallel parking

Use parking mode 2 to help you park on the side of a street.

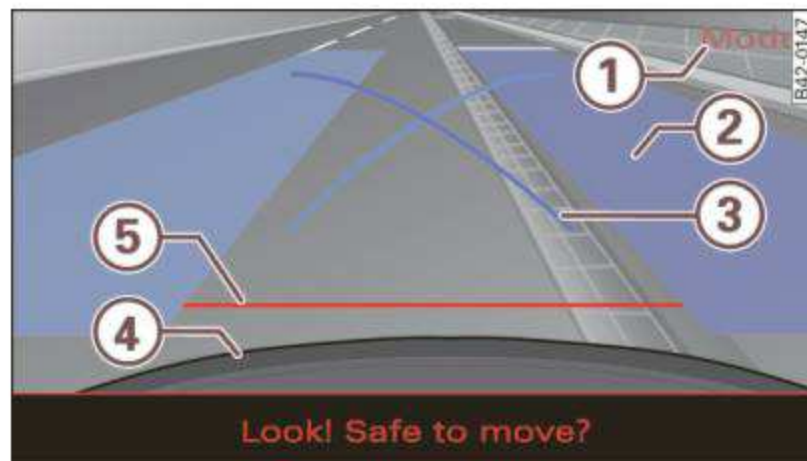

Fig. 80 Navigation system display: Blue surface aligned with parking spot

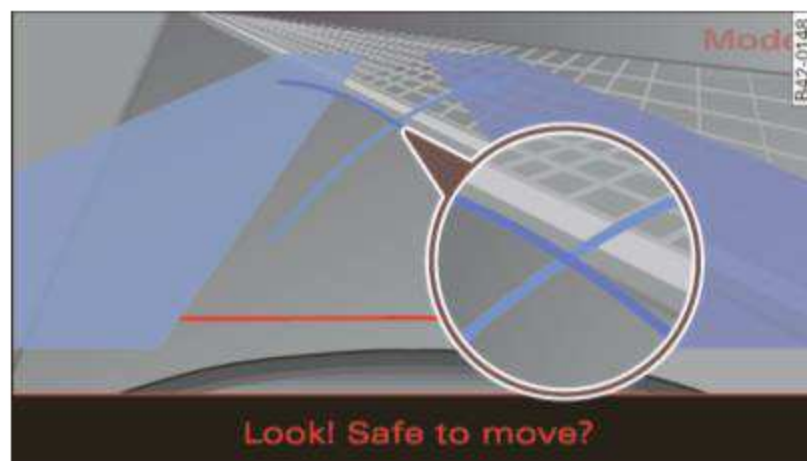

Fig. 81 Navigation system display: The blue curved line contacting the curb

The following steps apply only when there is *no* obstacle (such as a wall) near the parking spot. Otherwise, please read the "Tips on Parking Next to Obstacles".

- Position your vehicle parallel to the edge of the street, approximately 1 meter from a parked vehicle.
- Engage the reverse gear. The park assist turns on and parking mode 1 appears on the display.
- Press **Mode** (1) on the navigation system control button. Parking mode 2 appears ⇒ fig. 80.
- Back up and adjust the position of your vehicle so that the blue area (2) borders on the rear end of the vehicle or on the parking spot line. The blue area represents an extension of the vehicle's outline by approximately 5 m to the rear. The long side of the blue area should be on the curb. The entire blue area must fit into the parking spot.
- While the vehicle is stationary, turn the steering wheel to the right as far as it will go.
- Back up into the parking spot.
- Stop the vehicle as soon as the blue curve (3) touches the curb ⇒ fig. 81.
- While the vehicle is stationary, turn the steering wheel to the left as far as it will go.
- Continue to back up into the parking spot until the vehicle is parked parallel to the curb. (4) marks the rear bumper. You should stop driving in reverse when the red orientation line (5) meets an object, at the latest ⇒ !. Watch the front of the vehicle while doing this ⇒ !.

Tips on parking next to obstacles

When there is an obstacle (such as a wall) next to the parking spot, choose a spot with more space on the sides. Position the long side of the blue area so that there is sufficient space from the curb. The area must **not** contact the curb.

You will also need to start turning the steering wheel much earlier. There should be a sufficient amount of space between the curb and the blue curve, and the blue curve \Rightarrow *page 98*, fig. 81 must **not** touch the curb.

WARNING

- **The rearview camera does not show the entire area behind the vehicle \Rightarrow *page 95*, fig. 77. Watch out especially for small children and animals because the rearview camera cannot always detect them.**
- **Please note that objects not touching the ground can appear to be farther away than they really are (for example, the bumper of a vehicle or the rear of a truck). In this case, you should not use the orientation lines to help with parking.**
- **Maintain plenty of distance from obstacles so that your outside mirror or a corner of your vehicle does not come into contact with them.**

Note

The navigation system display shows the direction in which the rear of the vehicle is traveling based on the steering wheel angle. The vehicle front swings out more than the vehicle rear.

Tips

The left or right orientation lines and surfaces will be displayed, depending on the turn signal being used. ■

HomeLink®

Universal remote control

Applies to vehicles: with HomeLink® universal remote control

General information

The HomeLink® feature can learn up to three radio frequency codes for most current transmitters used for operating garage doors, estate gates, home or outdoor lighting systems, and other devices.

You must first program the HomeLink® transmitter before you can use the system ⇒ *page 101, "Programming the HomeLink® transmitter"*.

In order to program the HomeLink® transmitter for devices utilizing rolling code, a second person on a ladder who can safely reach the garage door opener motor is recommended. It is also necessary to locate the "learn" button on your garage door opener motor. Refer to the operating instructions for the opener, as the location and color of this button may vary by manufacturer.

You can still use the original remote control for the device at any time.

WARNING

- **Never use the HomeLink® transmitter with any garage door opener that does not have the safety stop and reverse feature as required by federal safety standards. This includes any garage door opener model manufactured before April 1, 1982.**
- **A garage door opener which cannot detect an object, signaling the door to stop and reverse does not meet current federal safety standards. Using a garage door opener without these features increases risk of serious injury or death.**

WARNING (continued)

- **For safety reasons never release the parking brake or start the engine while anyone is standing in front of the vehicle.**
- **A garage door or an estate gate may sometimes be set in motion when the HomeLink® remote control is being programmed. If the device is repeatedly activated, this can overstrain motor and damage its electrical components - an overheated motor is a fire hazard!**
- **To avoid possible injuries or property damage, please always make absolutely certain that no persons or objects are located in the range of motion of any equipment being operated.**

Tips

If you would like more information on HomeLink®, where to purchase the HomeLink® compatible products, or would like to purchase the HomeLink® Home Lighting Package, please call toll-free: 1-800-355-3515. ■

Applies to vehicles: with HomeLink® universal remote control

Programming the HomeLink® transmitter

The transmitter is programmed in two phases. For rolling code transmitters, a third phase is also necessary.

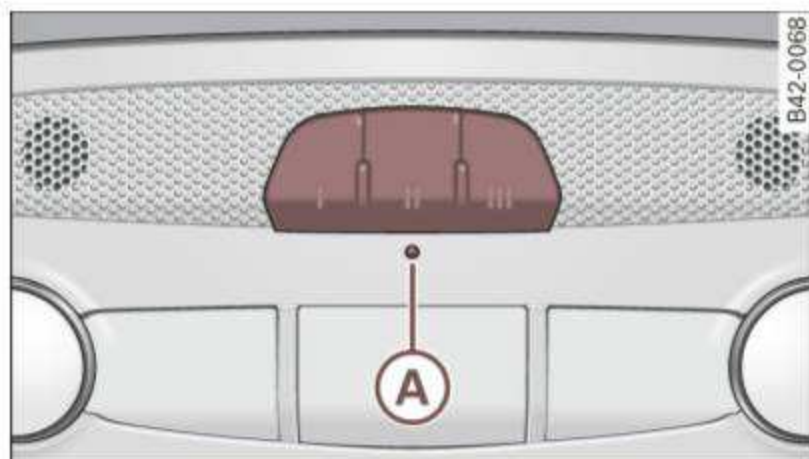

Fig. 82 Overhead console: HomeLink® keypad

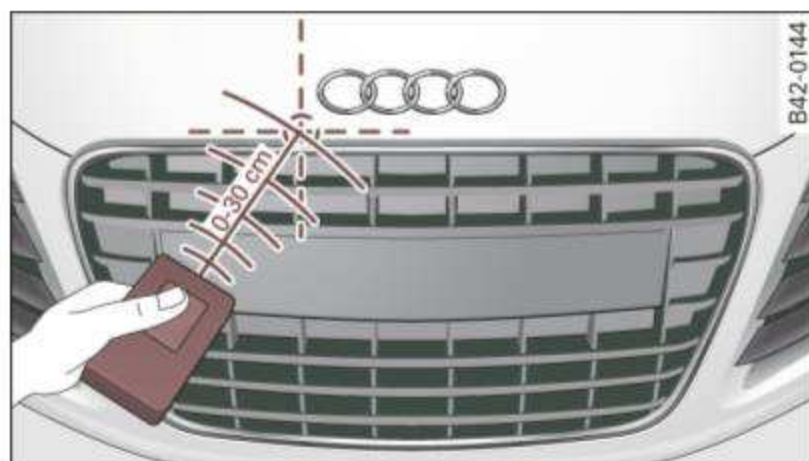









Fig. 83 Front bumper, driver side: location of transmitter unit

Phase 1: programming the overhead keypad

1. Make sure your vehicle is within operating range of the remote controlled garage door opener.
2. Set the parking brake ⇒  in "General information".
3. Turn the ignition on. Do not start the engine!

4. Press and hold the two outside HomeLink® buttons  and  for approximately 20 seconds until indicator light  ⇒ page 101, fig. 82 begins to flash. Then release both buttons. Do not hold the buttons for longer than 30 seconds.
 - This procedure only needs to be performed **once**. It erases the factory-set default codes and does not have to be repeated to program additional remote controls.
5. Press and hold the HomeLink® button ,  or  until the indicator light  starts flashing *slowly*. Release the button.
 - The system will remain in programming mode for 5 minutes. Go to the front of the vehicle and proceed with phase 2.

Phase 2: programming the bumper mounted transmitter

6. Hold the *original remote control* at a distance between 0–5 in. (0–13 cm) from the bumper below the appropriate headlight for your vehicle ⇒ fig. 83 (use the shortest distance possible).
7. Aim the remote control just below the **driver side** headlight.
8. Press and hold the activation button on the remote control.
 - May be different in Canada. If so, press and re-press (cycle) the activation button on your remote control every two seconds.

9. The emergency flashers will flash **three times** (after about 15–60 seconds) when the programming is successful. Release the button on the remote control.
 - *To program more devices, repeat steps 4 to 9.*
10. Press and hold the trained HomeLink® button and observe the indicator light (A) ⇒ *page 101, fig. 82.*
 - If the indicator light is solid/continuous, programming is complete and your device should activate when you press and release the trained HomeLink® button.
 - If the indicator light blinks rapidly for 2 seconds and is then a solid/continuous light, proceed with phase 3 to program a rolling code device.

Phase 3: rolling code programming

- A second person on a ladder who can safely reach the garage door opener motor is recommended.
11. Locate the “learn” button on the garage door opener motor (refer to the operating instructions for the opener, as the location of this button may vary by manufacturer).
 12. Press and release the learn button on the garage door opener motor.
 - **Note:** once the button is pressed, there are **30 seconds** in which to initiate the next step.
 13. On the HomeLink® keypad inside the vehicle, firmly press and hold the HomeLink® button previously programmed in phases 1 and 2 for two seconds and release. Repeat this sequence **twice**.

- Some vehicles may require the press/hold/release sequence up to three times to complete the training process.
- HomeLink® should now activate your rolling code equipped device.

If the 5 minute time limit is exceeded, the **emergency flashers will flash one time** to indicate that the process has been terminated. In this case, repeat steps 4 through 9.

If the emergency flashers do not flash *three* times (after about 15–60 seconds), programming was not successful. In this case, repeat steps 4 through 9.

Remote control units for garage door openers in Canada are set to stop transmitting radio frequency signals after two seconds. This time may not be sufficient for the HomeLink® system to learn the radio frequency signal. Perform all other steps as described above. ■

Applies to vehicles: with HomeLink® universal remote control

Operating the HomeLink® transmitter

The HomeLink® transmitter works in the same manner as the original handheld remote control that came with the system.

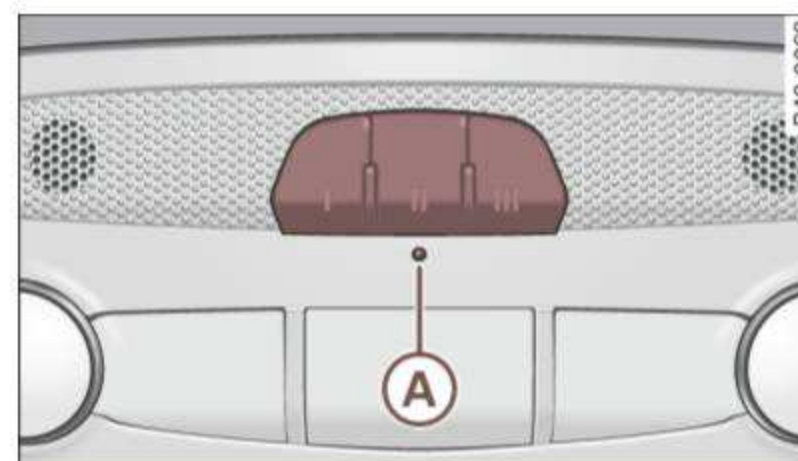





Fig. 84 Close-up:
HomeLink® keypad

- Press the appropriate programmed button ,  or  to activate the desired remote control function ⇒  in “General information” on *page 100*. ■

Applies to vehicles: with HomeLink® universal remote control

Reprogramming a single button

A HomeLink® button can be reprogrammed individually without affecting the other button allocations.

Programming the overhead keypad

- Press the appropriate HomeLink® button until the indicator light begins flashing slowly.

Programming the bumper mounted transmitter

1. Hold the *original remote control* at a distance between 0–5 in. (0–13 cm) from the bumper below the appropriate headlight for your vehicle (use the shortest distance possible).
 2. Aim the remote control just below the **driver side** headlight.
 3. Press and hold the activation button on the remote control.
 4. The emergency flashers will flash **three times** (after about 15–60 seconds) when the programming is successful. Now release the button on the remote control.
- If the device utilizes a rolling code, please follow phase 3 of ⇒ *page 101*, “Programming the HomeLink® transmitter” for rolling code programming.

This procedure will cause the existing programming on the HomeLink® button to be erased! ■

Applies to vehicles: with HomeLink® universal remote control

Erasing the programming of the HomeLink® transmitter

When you erase the programming, the programming on all three of the transmitter channels will be lost!

- Perform steps 1 to 4 as described on ⇒ *page 101*, “Phase 1: programming the overhead keypad”.

When completed, the HomeLink® system will be in the programming mode and is then ready to learn the codes for remote controlled devices.



Tips

- Programmed buttons cannot be erased individually.
- For security reasons you are advised to erase the programming of the HomeLink® system before you sell your vehicle. ■



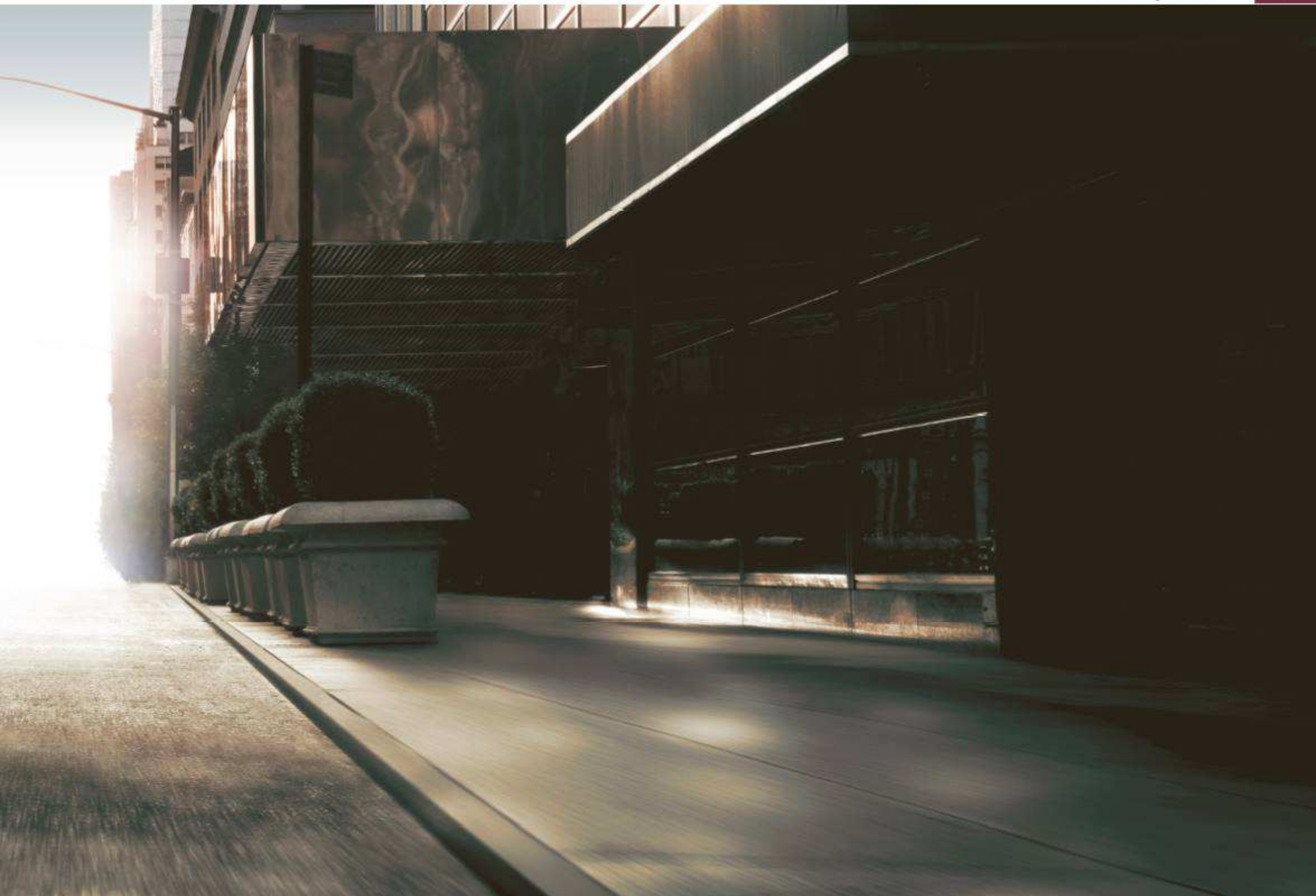

Driving Safely

General notes

Safe driving habits

Please remember - safety first!

This chapter contains important information, tips, instructions and warnings that you need to read and observe for your own safety, the safety of your passengers and others. We have summarized here what you need to know about safety belts, airbags, child restraints as well as child safety. Your safety is for us *priority number 1*. Always observe the information and warnings in this section - for your own safety as well as for that of your passengers.

The information in this section applies to all model versions of your vehicle. Some of the features described in this sections may be standard equipment on some models, or may be optional equipment on others. If you are not sure, ask your authorized Audi dealer.

WARNING

- **Make certain that you follow the instructions and heed the WARNINGS in this Manual. It is in your interest and in the interest of your passengers.**
- **Always keep the complete owner's literature in your Audi when you lend or sell your vehicle so that this important information will always be available to the driver and passengers.**
- **Always keep the owner's literature handy so that you can find it easily if you have questions. ■**

Safety equipment

The safety features are part of the occupant restraint system and work together to help reduce the risk of injury in a wide variety of accident situations.

Your safety and the safety of your passengers should not be left to chance. Advances in technology have made a variety of features available to help reduce the risk of injury in an accident. The following is a listing of just a few of the safety features in your Audi:

- sophisticated safety belts for driver and all passenger seating positions,
- safety belt pre-tensioners,
- front airbags,
- knee airbags for the front seats,
- side airbags in the front seats,
- adjustable head restraints,
- adjustable steering column.

These individual safety features can work together as a system to help protect you and your passengers in a wide range of accidents. These features cannot work as a system if they are not always properly adjusted and properly used!

Safety is everybody's responsibility! ■

Important things to do before driving

Safety is everybody's job! Vehicle and occupant safety always depends on the informed and careful driver.

For your safety and the safety of your passengers, **before driving always:** ►

- Make sure that all lights and signals are operating correctly.
 - Make sure that the tire pressure is correct.
 - Make sure that all windows are clean and afford good visibility to the outside.
 - Secure all luggage and other items carefully ⇒ *page 72*.
 - Make sure that nothing can interfere with the pedals.
 - Adjust front seat, head restraint and mirrors correctly for your height.
 - Instruct passengers to adjust the head restraints according to their height.
 - Make sure to use the right child restraint correctly to protect children ⇒ *page 147, "Child Safety"*.
 - Sit properly in your seat and make sure that your passengers do the same ⇒ *page 67, "Seats and storage"*.
 - Fasten your safety belt and wear it properly. Also instruct your passengers to fasten their safety belts properly ⇒ *page 116*. ■
- Do not let yourself be distracted by passengers or by using a cellular telephone.
 - NEVER drive when your driving ability is impaired (by medications, alcohol, drugs, etc.).
 - Observe all traffic laws, rules of the road and speed limits and plain common sense.
 - ALWAYS adjust your speed to road, traffic and weather conditions.
 - Take frequent breaks on long trips. Do not drive for more than two hours at a stretch.
 - Do NOT drive when you are tired, under pressure or when you are stressed.

**WARNING**

Impaired driving safety increases the risk of serious personal injury and death whenever a vehicle is being used. ■

What impairs driving safety?

Safe driving is directly related to the condition of the vehicle, the driver as well as the driver's ability to concentrate on the road without being distracted.

The driver is responsible for the safety of the vehicle and all of its occupants. If your ability to drive is impaired, safety risks for everybody in the vehicle increase and you also become a hazard to everyone else on the road ⇒ . Therefore:

Proper occupant seating positions

Proper seating position for the driver

The proper driver seating position is important for safe, relaxed driving.

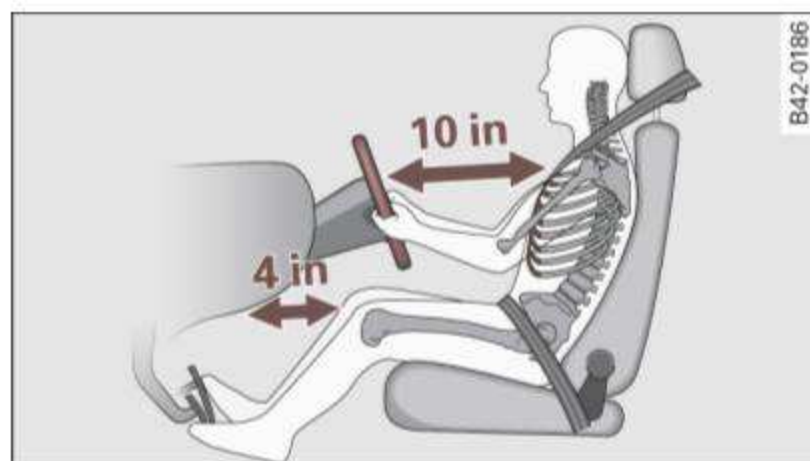

Fig. 85 The correct distance between driver and steering wheel

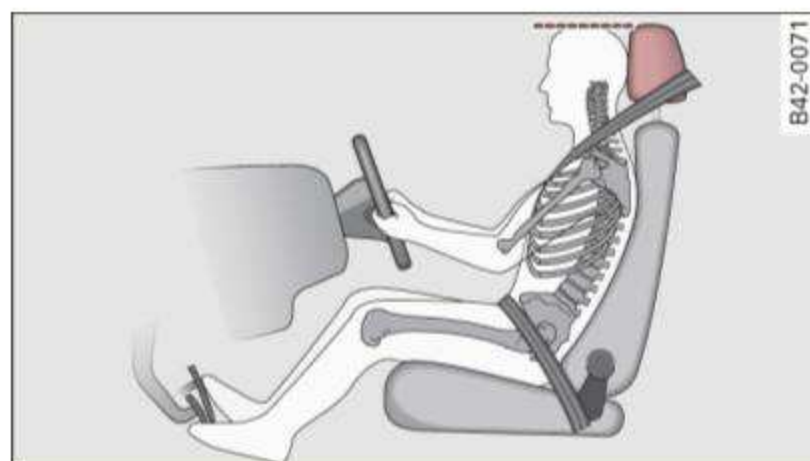



Fig. 86 Correct head restraint position for driver

For your own safety and to reduce the risk of injury in the event of an accident, we recommend that you adjust the driver's seat to the following position:

- Adjust the steering wheel so that there is a distance of at least 10 inches (25 cm) between the steering wheel and your breast bone ⇒ fig. 85.

- Adjust the driver's seat so that you can easily push the pedals all the way to the floor while keeping your knee(s) slightly bent ⇒ .
- Grasp the top of the steering wheel with your elbow(s) slightly bent.
- Adjust the head restraint so that the upper edge is as even with the top of your head as possible but no lower than eye level and so that it is as close to the back of your head as possible ⇒ fig. 86.
- Adjust the steering wheel so that the steering wheel and airbag cover points at your chest and not at your face.
- Adjust the angle of the seatback so that it is in an upright position so that your back comes in full contact with it when you drive.
- Fasten and wear safety belts correctly ⇒ *page 117*.
- Always keep both feet in the footwell so that you are in control of the vehicle at all times.

For detailed information on how to adjust the driver's seat, see ⇒ *page 67, "Seats and storage"*.

WARNING

Drivers who are unbelted, out of position or too close to the airbag can be seriously injured by an airbag as it deploys. To help reduce the risk of serious personal injury:

- Always adjust the driver's seat and the steering wheel so that there are at least 10 inches (25 cm) between your breastbone and the steering wheel.
- Always adjust the driver's seat and the steering wheel so that there are at least 4 inches (10 cm) between the knees and the lower part of the instrument panel.

 WARNING (continued)

- Always hold the steering wheel on the outside of the steering wheel rim with your hands at the 9 o'clock and 3 o'clock positions to help reduce the risk of personal injury if the driver's airbag inflates.
- Never hold the steering wheel at the 12 o'clock position or with your hands at other positions inside the steering wheel rim or on the steering wheel hub. Holding the steering wheel the wrong way can cause serious injuries to the hands, arms and head if the driver's airbag inflates
- Pointing the steering wheel toward your face decreases the ability of the supplemental driver's airbag to protect you in a collision.
- Always sit in an upright position and never lean against or place any part of your body too close to the area where the airbags are located.
- Before driving, always adjust the front seats and head restraints properly and make sure that all passengers are properly restrained.
- Never adjust the seats while the vehicle is moving. Your seat may move unexpectedly and you could lose control of the vehicle.
- Never drive with the backrest reclined or tilted far back! The farther the backrests are tilted back, the greater the risk of injury due to incorrect positioning of the safety belt and improper seating position.
- Children must always ride in child seats ⇒ *page 147*. Special precautions apply when installing a child seat on the front passenger seat ⇒ *page 125*. ■

Proper seating position for the front passenger

The proper front passenger seating position is important for safe, relaxed driving.

For your own safety and to reduce the risk of injury in the event of an accident, we recommend that you adjust the seat for the front passenger to the following position:

- Move the front passenger seat back as far as possible. There must be a minimum of 10 inches (25 cm) between the breastbone and the instrument panel ⇒ .
- Adjust the angle of the seatback so that it is in an upright position and your back comes in full contact with it whenever the vehicle is moving.
- Adjust the head restraint so that the upper edge is as even with the top of your head as possible but not lower than eye level and so that it is as close to the back of your head as possible ⇒ *page 110*.
- Keep both feet flat on the floor in front of the front passenger seat.
- Fasten and wear safety belts correctly ⇒ *page 120*.

For detailed information on how to adjust the front passenger's seat, see ⇒ *page 67*, "Seats and storage".

 WARNING

Front seat passengers who are unbelted, out of position or too close to the airbag can be seriously injured or killed by the airbag as it deploys. To help reduce the risk of serious personal injury: ►

⚠ WARNING (continued)

- Passengers must always sit in an upright position and never lean against or place any part of their body too close to the area where the airbags are located.
- Passengers who are unbelted, out of position or too close to the airbag can be seriously injured by an airbag as it deploys with great force in the blink of an eye.
- Always make sure that there are at least 10 inches (25 cm) between the front passenger's breastbone and the instrument panel.
- Always make sure that there are at least 4 inches (10 cm) between the front passenger's knees and the lower part of the instrument panel.
- Each passenger must always sit on a seat of their own and properly fasten and wear the safety belt belonging to that seat.
- Before driving, always adjust the front passenger seat and head restraint properly.
- Always keep your feet on the floor in front of the seat. Never rest them on the seat, instrument panel, out of the window, etc. The airbag system and safety belt will not be able to protect you properly and can even increase the risk of injury in a crash.
- Never drive with the backrest reclined or tilted far back! The farther the backrests are tilted back, the greater the risk of injury due to incorrect positioning of the safety belt and improper seating position.
- Children must always ride in child seats ⇒ *page 147*. Special precautions apply when installing a child seat on the front passenger seat ⇒ *page 125*. ■

Proper adjustment of head restraints

Correctly adjusted head restraints are an important part of your vehicle's occupant restraint system and can help to reduce the risk of injuries in accident situations.

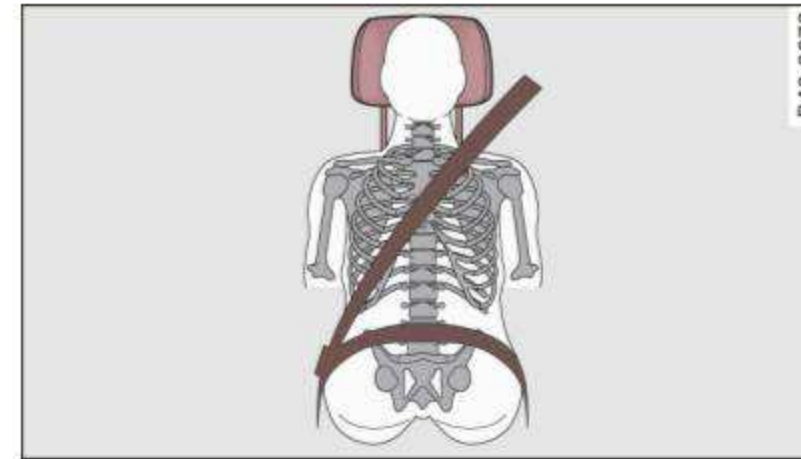

Fig. 87 Correctly adjusted head restraint viewed from the front

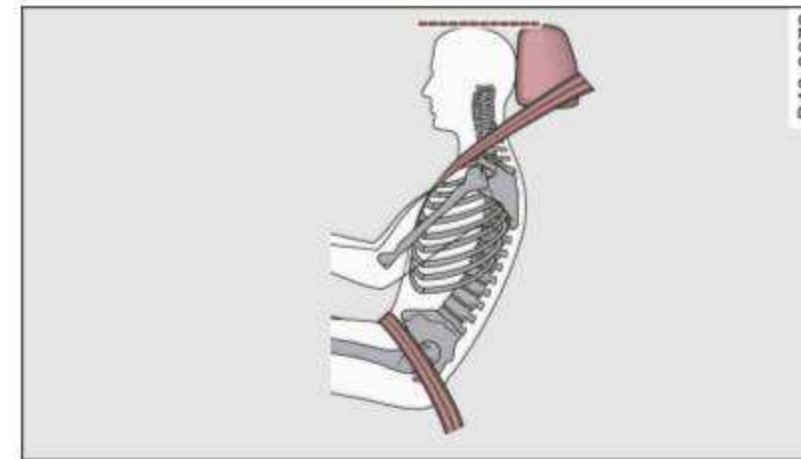

Fig. 88 Correctly adjusted head restraint viewed from the side

The head restraints must be correctly adjusted to achieve the best protection.

- Adjust the head restraint so that the upper edge of the restraint is level with the top of your head, but no lower than eye level and so it is as close to the back of your head as possible ⇒ *fig. 87* and ⇒ *fig. 88*.

Adjusting head restraints ⇒ *page 70*.



 **WARNING**

Driving without head restraints or with improperly adjusted head restraints increases the risk of serious injuries in a collision. To help reduce the risk of injury:

- Always drive with the head restraints in place and properly adjusted.
- Every person in the vehicle must have a properly adjusted head restraint.
- Always make sure each person in the vehicle properly adjusts their head restraint. Each head restraint must be adjusted according to occupants' size so that the upper edge is as even with the top of the person's head, but no lower than eye level and so it is as close to the back of the head as possible.
- Never attempt to adjust head restraint while driving. If you have driven off and must adjust the driver headrest for any reason, first stop the vehicle safely before attempting to adjust the head restraint.
- Children must always be properly restrained in a child restraint that is appropriate for their age and size ⇒ *page 147*. ■

Examples of improper seating positions

The occupant restraint system can only reduce the risk of injury if vehicle occupants are properly seated.

Improper seating positions can cause serious injury or death. Safety belts can only work when they are properly positioned on the body. Improper seating positions reduce the effectiveness of safety belts and will even increase the risk of injury and death by moving the safety belt to critical areas of the body. Improper seating positions also increase the risk of serious injury and death when an airbag deploys and strikes an occupant who is not in the proper seating

position. A driver is responsible for the safety of all vehicle occupants and especially for children. Therefore:

- Never allow anyone to assume an incorrect seating position when the vehicle is being used ⇒ .

The following bullets list only some sample positions that will increase the risk of serious injury and death. Our hope is that these examples will make you more aware of seating positions that are dangerous.

Therefore, whenever the vehicle is moving:

- never stand up in the vehicle
- never stand on the seats
- never kneel on the seats
- never ride with the seatback reclined
- never lean up against the instrument panel
- never sit on the edge of the seat
- never sit sideways
- never lean out the window
- never put your feet out the window
- never put your feet on the instrument panel
- never rest your feet on the seat cushion or back of the seat
- never ride in the footwell
- never ride in the cargo area

 **WARNING**

Improper seating positions increase the risk of serious personal injury and death whenever a vehicle is being used.

- **Sitting incorrectly places occupants at risk of being critically injured if the airbags deploy and strike them.**
- **Before you start driving, seat yourself properly and always maintain this seating position during the trip. Before each trip,**

⚠ WARNING (continued)

instruct your passengers to seat themselves properly and to maintain this seating position during the trip ⇒ page 67, "Seats and storage". ■

Driver and passenger side footwell

Important safety instructions

⚠ WARNING

Always make sure that the knee airbag can inflate without interference. Objects between yourself and the airbag can increase the risk of injury in an accident by interfering with the way the airbag deploys or by being pushed into you as the airbag deploys.

- No persons (children) or animals should ride in the footwell in front of the passenger seat. If the airbag deploys, this can result in serious or fatal injuries.
- No objects of any kind should be carried in the footwell area in front of the driver's or passenger's seat. Bulky objects (shopping bags, for example) can hamper or prevent proper deployment of the airbag. Small objects can be thrown through the vehicle if the airbag deploys and injure you or your passengers. ■

Pedal area

The pedals must always be free to move and must never be interfered with by a floor mat or any other object.

- Make sure that all pedals move freely without interference.
- Make sure that nothing prevents all pedals from returning to their original positions.

Only use floor mats that leave the pedal area free and can be secured with floor mat fasteners.

If a brake circuit fails, increased brake pedal travel is required to bring the vehicle to a full stop.

⚠ WARNING

Pedals that cannot move freely can cause loss of vehicle control and increase the risk of serious injury.

- Never place any objects in the driver's footwell. An object could get into the pedal area and interfere with pedal function. In case of sudden braking or an accident, you would not be able to brake or accelerate!
- Always make sure that nothing can fall or move into the driver's footwell. ■

Floor mats on the driver side

Always use floor mats that can be securely attached to the floor mat fasteners and do not interfere with the free movement of the pedals.

- Make sure that the floor mats are properly secured and cannot move and interfere with the pedals ⇒ ⚠.

Use only floor mats that leave the pedal area unobstructed and that are firmly secured so that they cannot slip out of position. You can obtain suitable floor mats from your authorized Audi dealer.

⚠ WARNING

Pedals that cannot move freely can result in a loss of vehicle control and increase the risk of serious personal injury.

- Always make sure that floor mats are properly secured. ▶

⚠ WARNING (continued)

- **Never place or install floor mats or other floor coverings in the vehicle that cannot be properly secured in place to prevent them from slipping and interfering with the pedals or the ability to control the vehicle.**
- **Never place or install floor mats or other floor coverings on top of already installed floor mats. Additional floor mats and other coverings will reduce the size of the pedal area and interfere with the pedals.**
- **Always properly reinstall and secure floor mats that have been taken out for cleaning.**
- **Always make sure that objects cannot fall into the driver footwell while the vehicle is moving. Objects can become trapped under the brake pedal and accelerator pedal causing a loss of vehicle control. ■**

Stowing luggage

Loading the luggage compartment

All luggage and other objects must be properly stowed and secured in the luggage compartment.

Loose items in the luggage compartment can shift suddenly, changing vehicle handling characteristics. Loose items can also increase the risk of serious personal injury in a sudden vehicle maneuver or in a collision.

In a collision, the laws of physics mean that even smaller items that are loose in the vehicle will become heavy missiles that can cause serious injury. Items in the vehicle possess energy which vary with vehicle speed and the weight of the item. Vehicle speed is the most significant factor.

For example, in a frontal collision at a speed of 30 mph (48 km/h), the forces acting on a 10-lb (4.5 kg) object are about 20 times the

normal weight of the item. This means that the weight of the item would suddenly be about 200 lbs. (90 kg). You can imagine the injuries that a 200 lbs. (90 kg) item flying freely through the passenger compartment could cause in a collision like this.

⚠ WARNING

Improperly stored luggage or other items can fly through the vehicle causing serious personal injury in the event of hard braking or an accident. To help reduce the risk of serious personal injury:

- **Always put objects, for example, luggage or other heavy items in the luggage compartment.**

⚠ WARNING

Heavy loads will influence the way your vehicle handles. To help reduce the risk of a loss of control leading to serious personal injury:

- **Always keep in mind when transporting heavy objects, that a change in the center of gravity can also cause changes in vehicle handling.**
- **Never exceed the Gross Axle Weight Rating or the Gross Vehicle Weight Rating specified on the safety compliance sticker on the left door jamb. Exceeding permissible weight standards can cause the vehicle to slide and handle differently.**
- **Please observe information on safe driving ⇒ page 106.**

⚠ WARNING

Always make sure that the doors, all windows and the front lid are securely closed and locked to reduce the risk of injury when the vehicle is not being used.

- **After closing the front lid, always make sure that it is properly closed and locked.**

⚠ WARNING (continued)

- Never leave your vehicle unattended especially with the front lid left open. A child could crawl into the luggage compartment and close the front lid becoming trapped and unable to get out. Being trapped in a vehicle can lead to serious personal injury.
- Never let children play in or around the vehicle.
- Never let passengers ride in the luggage compartment. Vehicle occupants must always be properly restrained in one of the vehicle's seating positions.

 Tips

The tire pressure must correspond to the load - see the tire pressure sticker on the side B-pillar of the driver door. ■

Reporting Safety Defects**Applicable to U.S.A.**

If you believe that your vehicle has a defect which could cause a crash or could cause injury or death, you should immediately inform the National Highway Traffic Safety Administration (NHTSA) in addition to notifying Audi of America, Inc.

If NHTSA receives similar complaints, it may open an investigation, and if it finds that a safety defect exists in a group of vehicles, it may order a recall and remedy campaign. However, NHTSA cannot become involved in

individual problems between you, your dealer, or Audi of America, Inc.

To contact NHTSA, you may call the Vehicle Safety Hotline toll-free at:

Tel.: 1-888-327-4236 (TTY: 1-800-424-9153)

or write to:

Administrator

NHTSA

1200 New Jersey Avenue, SE

Washington, D.C. 20590

You can also obtain other information about motor vehicle safety from:

<http://www.safercar.gov>

Applicable to Canada

Canadian customers who wish to report a safety-related defect to Transport Canada, Defect Investigations and Recalls, may telephone the toll free hotline:

Tel.: 1-800-333-0371

or contact Transport Canada by mail at:

Road Safety and Motor Vehicle Regulation
Directorate

Transport Canada

Tower C, Place de Ville, 

330 Sparks Street
Ottawa, ON K1A 0N5

For additional road safety information, please
visit the Road Safety website at:

<http://www.tc.gc.ca/roadsafety/menu.htm> ■

Safety belts

General notes

Always wear safety belts!

Wearing safety belts correctly saves lives!

This chapter explains why safety belts are necessary, how they work and how to adjust and wear them correctly.

- Read all the information that follows and heed all of the instructions and WARNINGS.

WARNING

Not wearing safety belts or wearing them improperly increases the risk of serious personal injury and death.

- Safety belts are the single most effective means available to reduce the risk of serious injury and death in automobile accidents. For your protection and that of your passengers, always correctly wear safety belts when the vehicle is moving.
- Pregnant women, injured, or physically impaired persons must also use safety belts. Like all vehicle occupants, they are more likely to be seriously injured if they do not wear safety belts. The best way to protect a fetus is to protect the mother - throughout the entire pregnancy. ■

Number of seats

Your Audi R8 has two seating positions in the front. Each seating position has a safety belt.

WARNING

Not wearing safety belts or wearing them improperly increases the risk of serious personal injury and death.

- Never strap more than one person, including small children, into any belt. It is especially dangerous to place a safety belt over a child sitting on your lap.
- Never let more people ride in the vehicle than there are safety belts available.
- Be sure everyone riding in the vehicle is properly restrained with a separate safety belt or child restraint. ■

Safety belt warning light

Your vehicle has a warning system for the driver and front seat passenger to remind you about the importance of buckling up.



Fig. 89 Safety belt warning light in the instrument cluster - enlarged

Before driving off, always:

- Fasten your safety belt and make sure you wear it properly. ▶

- Make sure that your passengers also buckle up and wear their safety belts properly.
- Protect children with a child restraint system appropriate for the size and age.

The warning light  in the instrument cluster lights up when the ignition is switched on as a reminder to fasten the safety belts. In addition, you will hear a warning tone.

After the ignition is switched on, the warning light will always come on for about 6 seconds and if the driver has not fastened the safety belt, a warning tone will also sound for about 6 seconds. As soon as the driver has fastened his safety belt, the warning tone will stop and the warning light will go out.

If the driver or front seat passenger has not buckled up within about 10 seconds after the warning tone has stopped and the vehicle is moving faster than about 15 mph (24 km/h), the warning tone will sound again for about 6 seconds and then stop for 24 seconds and then repeat this reminder sequence for a maximum of 2 minutes. At speeds below 5 mph (8 km/h), the warning tone will not sound.

Fasten your safety belt and make sure that your passengers also put on their safety belts properly.

WARNING

- **Safety belts are the single most effective means available to reduce the risk of serious injury and death in automobile accidents. For your protection and that of your passengers, always wear safety belts correctly when the vehicle is moving.**
- **Failure to pay attention to the warning light that comes on could lead to personal injury. ■**

Why safety belts?

Safety belts protect

People think it's possible to use the hands to brace the body in a minor collision. It's simply not true!



Fig. 90 Driver is properly restrained in a sudden braking maneuver.

Safety belts used properly can make a big difference. Safety belts help to keep passengers in their seats, gradually reduce energy levels applied to the body in an accident, and help prevent the uncontrolled movement that can cause serious injuries. In addition, safety belts reduce the danger of being thrown out of the vehicle.

Safety belts attach passengers to the car and give them the benefit of being slowed down more gently or “softly” through the “give” in the safety belts, crush zones and other safety features engineered into today's vehicles. By “absorbing” the kinetic energy over a longer period of time, the safety belts make the forces on the body more “tolerable” and less likely to cause injury.

Although these examples are based on a frontal collision, safety belts can also substantially reduce the risk of injury in other kinds of crashes. So, whether you're on a long trip or just going to the corner store, always buckle up and make sure others do, too. Accident statistics show that vehicle occupants properly wearing safety belts have a lower risk of being injured and a much better chance of surviving an accident. Properly using safety belts also greatly

increases the ability of the supplemental airbags to do their job in a collision. For this reason, wearing a safety belt is legally required in most countries including much of the United States and Canada.

Although your Audi is equipped with airbags, you still have to wear the safety belts provided. Front airbags, for example, are activated only in some frontal collisions. The front airbags are not activated in all frontal collisions, in side and rear collisions, in roll overs or in cases where there is not enough deceleration through impact to the front of the vehicle. The same goes for the other airbag systems in your Audi. So, always wear your safety belt and make sure everybody in your vehicle is properly restrained! ■

Important safety instructions about safety belts

Safety belts must always be properly positioned across the strongest bones of your body.

- Always wear safety belts as illustrated and described in this chapter.
- Make sure that your safety belts are always ready for use and are not damaged.

WARNING

Not wearing safety belts or wearing them improperly increases the risk of serious personal injury and death. Safety belts can work only when used correctly.

- Always fasten your safety belts correctly before driving off and make sure all passengers are properly restrained.
- For maximum protection, safety belts must always be positioned correctly on the body.
- Never strap more than one person, including small children, into any single safety belt.

WARNING (continued)

- Never place a safety belt over a child sitting on your lap.
- Always keep feet in the footwell in front of the seat while the vehicle is being driven.
- Never let any person ride with feet on the instrument panel or sticking out the window or on the seat.
- Never remove a safety belt while the vehicle is moving. Doing so will increase your risk of being injured or killed.
- Never wear belts twisted.
- Never wear belts over rigid or breakable objects in or on your clothing, such as eye glasses, pens, keys, etc., as these may cause injury.
- Never wear the shoulder part of the belt under your arm or otherwise out of position.
- Several layers of heavy clothing may interfere with correct positioning of belts and reduce their effectiveness.
- Always keep belt buckles free of anything that may prevent the buckle from latching securely.
- Never use comfort clips or devices that create slack in the shoulder belt. However, special clips may be required for the correct use of some child restraint systems.
- Never allow safety belts to become damaged by being caught in door or seat hardware.
- Torn or frayed safety belts can tear and damaged belt hardware can break in an accident. Inspect belts regularly. If webbing, bindings, buckles, or retractors are damaged, have belts replaced by an authorized Audi dealer or qualified workshop.
- Safety belts that have been worn and loaded in an accident must be replaced with the correct replacement safety belt by an authorized Audi dealer or qualified workshop. Replacement may be necessary even if damage cannot be clearly seen. Anchorages that were loaded must also be inspected.

⚠ WARNING (continued)

- Never remove, modify, disassemble, or try to repair the safety belts yourself.
- Always keep the belts clean. Dirty belts may not work properly and can impair the function of the inertia reel ⇒ *page 184, "Safety belts"*. ■

Illustrating the principle of an accident

Frontal collisions and the law of physics

Frontal crashes create very strong forces for people riding in vehicles.

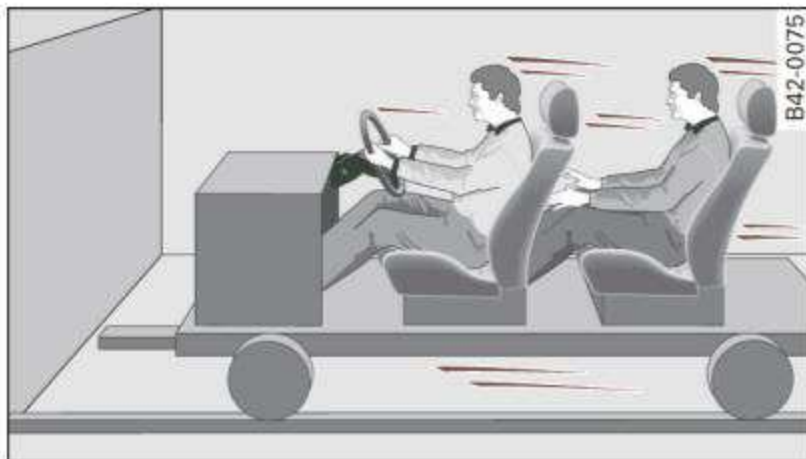

Fig. 91 Unbelted occupants in a vehicle heading for a wall



Fig. 92 The vehicle crashes into the wall.

The physical principles are simple. Both the vehicle and the passengers possess energy which varies with vehicle speed and body weight. Engineers call this energy "kinetic energy."

The higher the speed of the vehicle and the greater the vehicle's weight, the more energy that has to be "absorbed" in the crash.

Vehicle speed is the most significant factor. If the speed doubles from 15 to 30 mph (25 to 50 km/h), the energy increases 4 times!

Because the occupants in this vehicle are not using safety belts ⇒ fig. 91, they will keep moving at the same speed the vehicle was moving just before the crash, until something stops them - here, the wall ⇒ fig. 92.

The same principles apply to people sitting in a vehicle that is involved in a frontal collision. Even at city speeds of 20 to 30 mph (30 to 50 km/h), the forces acting on the body can reach one ton (2,000 lbs, or 1,000 kg) or more. At higher speeds, these forces are even greater.

People who do not use safety belts are also not attached to their vehicle. In a frontal collision they will also keep moving forward at the speed their vehicle was travelling just before the crash. Of course, the laws of physics don't just apply to frontal collisions, they determine what happens in all kinds of accidents and collisions. ■

What happens to occupants not wearing safety belts?

In crashes, unbelted occupants cannot stop themselves from flying forward and being injured or killed. Always wear your safety belts!



Fig. 93 A driver not wearing a safety belt is violently thrown forward

Unbelted occupants are not able to resist the tremendous forces of impact by holding tight or bracing themselves. Without the benefit of safety restraint systems, the unrestrained occupant will slam violently into the steering wheel, instrument panel, windshield, or whatever else is in the way ⇒ fig. 93. This impact with the vehicle interior has all the energy they had just before the crash.

Never rely on airbags alone for protection. Even when they deploy, airbags provide only additional protection. Airbags are not supposed to deploy in all kinds of accidents. Although your Audi is equipped with airbags, all vehicle occupants, including the driver, must wear safety belts correctly in order to minimize the risk of severe injury or death in a crash.

Remember too, that airbags will deploy only once and that your safety belts are always there to offer protection in those accidents in which airbags are not supposed to deploy or when they have already deployed. Unbelted occupants can also be thrown out of the vehicle where even more severe or fatal injuries can occur. ■

How are safety belts worn correctly?

Fastening safety belts

Seat first - everybody buckle up!



Fig. 94 Head restraint adjustment and belt position

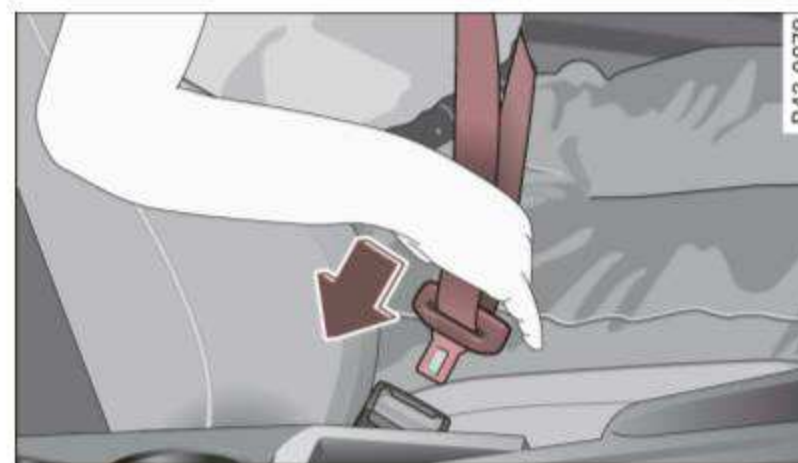



Fig. 95 Belt buckle and tongue on the driver's seat

To provide maximum protection, safety belts must always be positioned correctly on the wearer's body.

- Adjust the front seat and head restraint properly ⇒ *page 67, "Seats and storage"*.
- Hold the belt by the tongue and pull it evenly across the chest and pelvis ⇒ .

- Insert the tongue into the correct buckle of your seat until you hear it latch securely ⇒ *page 120*, fig. 95.
- Pull on the belt to make sure that it is securely latched in the buckle.

Automatic safety belt retractors

Every safety belt is equipped with an automatic belt retractor on the shoulder belt. This feature locks the belt when the belt is pulled out fast, during hard braking and in an accident. The belt may also lock when you drive up or down a steep hill or through a sharp curve. During normal driving the belt lets you move freely.

Switchable locking feature

Every safety belt except the one on the driver seat is equipped with a switchable locking feature that **must** be used when the safety belt is used to attach a child seat. Be sure to read the important information about this feature ⇒ *page 156*.

WARNING

Improperly positioned safety belts can cause serious injury in an accident ⇒ *page 121*, "Safety belt position".

- Safety belts offer optimum protection only when the seat back is upright and belts are properly positioned on the body.
- Never attach the safety belt to the buckle for another seat. Attaching the belt to the wrong buckle will reduce safety belt effectiveness and can cause serious personal injury.
- A passenger who is not properly restrained can be seriously injured by the safety belt itself when it moves from the stronger parts of the body into critical areas like the abdomen.
- Always lock the convertible locking retractor when you are securing a child seat in the vehicle ⇒ *page 158*. ■

Safety belt position

Correct belt position is the key to getting maximum protection from safety belts.

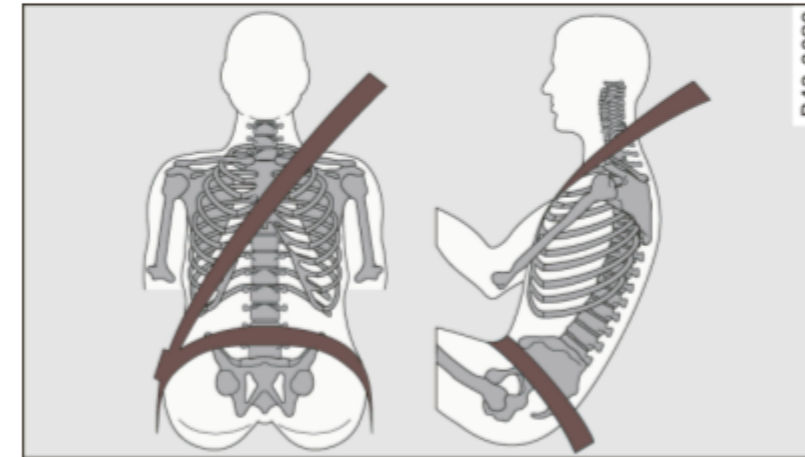

Fig. 96 Head restraint and safety belt position as seen from the side

Use the height adjustment to change the position of the shoulder straps of the front seat safety belts.

WARNING

Improperly positioned safety belts can cause serious personal injury in an accident.

- The shoulder belt portion of the safety belt must be positioned over the middle of the occupant's shoulder and never across the neck or throat.
- The safety belt must lie flat and snug on the occupant's upper body ⇒ fig. 96. Pull on the belt to tighten if necessary.
- The lap belt portion of the safety belt must be positioned as low as possible across pelvis and never over the abdomen. Make sure the belt lies flat and snug ⇒ fig. 96. Pull on the belt to tighten if necessary.
- A loose-fitting safety belt can cause serious injuries by shifting its position on your body from the strong bones to more vulnerable, soft tissue and cause serious injury.

⚠ WARNING (continued)

- Always read and heed all WARNINGS and other important information ⇒ *page 118*. ■

Pregnant women must also be properly restrained

The best way to protect the fetus is to make sure that expectant mothers always wear safety belts correctly - throughout the pregnancy.



Fig. 97 Safety belt position during pregnancy

To provide maximum protection, safety belts must always be positioned correctly on the wearer's body ⇒ *page 121*.

- Adjust the front seat and head restraint correctly ⇒ *page 67*, "Seats and storage".
- Hold the belt by the tongue and pull it evenly across the chest so that it sits as low as possible on the pelvis and there is no pressure on the abdomen ⇒ fig. 97 ⇒ ⚠.
- Insert the tongue into the correct buckle of your seat until you hear it latch securely ⇒ *page 120*, fig. 95.

- Pull on the belt to make sure that it is securely latched in the buckle.

⚠ WARNING

Improperly positioned safety belts can cause serious personal injury in an accident.

- Expectant mothers must always wear the lap portion of the safety belt as low as possible across the pelvis and below the rounding of the abdomen.
- Always read and heed all WARNINGS and other important information ⇒ ⚠ in "Fastening safety belts" on *page 120*. ■

Unfastening safety belts

Unbuckle the safety belt with the red release button only after the vehicle has stopped.



Fig. 98 Releasing the tongue from the buckle

- Push the red release button on the buckle ⇒ fig. 98. The belt tongue will spring out of the buckle ⇒ ⚠.
- Let the belt wind up on the retractor as you guide the belt tongue to its stowed position. ▶

 **WARNING**

Never unfasten safety belt while the vehicle is moving. Doing so will increase your risk of being injured or killed. ■

Improperly worn safety belts

Incorrectly positioned safety belts can cause severe injuries.

Wearing safety belts improperly can cause serious injury or death. Safety belts can only work when they are correctly positioned on the body. Improper seating positions reduce the effectiveness of safety belts and will even increase the risk of injury and death by moving the safety belt to critical areas of the body. Improper seating positions also increase the risk of serious injury and death when an airbag deploys and strikes an occupant who is not in the correct seating position. A driver is responsible for the safety of all vehicle occupants and especially for children. Therefore:

- Never permit anyone to assume an incorrect sitting position in the vehicle while traveling ⇒ .

 **WARNING**

Improperly worn safety belts increase the risk of serious personal injury and death whenever a vehicle is being used.

- Always make sure that all vehicle occupants are correctly restrained and stay in a correct seating position whenever the vehicle is being used.
- Always read and heed all WARNINGS and other important information ⇒ *page 118*. ■

Safety belt pretensioners

How safety belt pretensioners work

In front, side and rear end collisions above a particular severity, safety belts in use are tensioned automatically.

The safety belts for the front seating positions are equipped with safety belt pretensioners. The system is activated by sensors in front, side and rear-end collisions of great severity. This tightens the belt and takes up belt slack ⇒  in “Service and disposal of safety belt pretensioner” on *page 124*. Taking up the slack helps to reduce forward occupant movement during a collision.



Tips

The safety belt pretensioner can only be activated once.

- In minor frontal and side collisions, in rear-end collisions, in a rollover and in accidents involving very little impact force, the safety belt pretensioners are not activated.
- When the safety belt pretensioner is activated, a fine dust is released. This is normal and is not caused by a fire in the vehicle.
- The relevant safety requirements must be observed when the vehicle or components of the system are scrapped. An authorized Audi dealer is familiar with these regulations and will be pleased to pass on the information to you.
- Be sure to observe all safety, environmental and other regulations if the vehicle or individual parts of the system, particularly the safety belt or airbag, are to be disposed. We recommend you have your authorized Audi dealer perform this service for you. ■

Service and disposal of safety belt pretensioner

The safety belt pretensioners are parts of the safety belts on your Audi. Installing, removing, servicing or repairing of belt pretensioners can damage the safety belt system and prevent it from working correctly in a collision.

There are some important things you have to know to make sure that the effectiveness of the system will not be impaired and that discarded components do not cause injury or pollute the environment.

WARNING

Improper care, servicing and repair procedures can increase the risk of personal injury and death by preventing a safety belt pretensioner from activating when needed or activating it unexpectedly:

- **The belt pretensioner system can be activated only once. If belt pretensioners have been activated, the system must be replaced.**
- **Never repair, adjust, or change any parts of the safety belt system.**
- **Safety belt systems including safety belt pretensioners cannot be repaired. Special procedures are required for removal, installation and disposal of this system.**
- **For any work on the safety belt system, we strongly recommend that you see your authorized Audi dealer or qualified technician who has an Audi approved repair manual, training and special equipment necessary.**



For the sake of the environment

Undeployed airbag modules and pretensioners might be classified as Perchlorate Material -special handling may apply, see www.dtsc.ca.gov/hazardouswaste/perchlorate. When the vehicle or

parts of the restraint system including airbag modules, safety belts with pretensioners are scrapped, all applicable laws and regulations must be observed. Your authorized Audi dealer is familiar with these requirements and we recommend that you have your dealer perform this service for you. ■

Airbag system

Important things to know

Importance of wearing safety belts and sitting properly

Airbags are only supplemental restraints. For airbags to do their job, occupants must always wear their safety belts properly and be in a proper seating position.

For your safety and the safety of your passengers, before driving off, always:

- Adjust the driver's seat and steering wheel properly ⇒ *page 108,*
- Adjust the front passenger's seat properly ⇒ *page 109,*
- Wear safety belts properly ⇒ *page 118,*
- Always use the proper child restraint to protect children properly ⇒ *page 147.*

In a collision airbags must inflate within the blink of an eye and with considerable force. The supplemental airbags can cause injuries if the driver or the front seat passenger are not seated properly. Therefore in order to help the airbag to do its job, it is important, both as a driver and as a passenger to sit properly at all times.

By keeping room between your body and the steering wheel and the front of the passenger compartment, the airbag can inflate fully and completely and provide supplemental protection in certain frontal collisions ⇒ *page 108, "Proper occupant seating positions".* For details on the operation of the seat adjustment controls ⇒ *page 68.*

It's especially important that children are properly restrained ⇒ *page 147.*

There is a lot that the driver and the passengers can and must do to help the individual safety features installed in your Audi work together as a system.

Proper seating position is important so that the front airbag on the driver side can do its job. If you have a physical impairment or condition that prevents you from sitting properly on the driver seat with the safety belt properly fastened and reaching the pedals, or if you have concerns with regard to the function or operation of the airbag system, please contact your authorized Audi dealer or qualified workshop, or call Audi Customer CARE at 1-800-822-2834 for possible modification to your vehicle.

When the airbag system deploys, a gas generator will fill the airbags, break open the padded covers, and inflate between the steering wheel and the driver and between the instrument panel and the front passenger. The airbags will deflate immediately after deployment so that the front occupants can see through the windshield again without interruption.

All of this takes place in the blink of an eye, so fast that many people don't even realize that the airbags have deployed. The airbags also inflate with a great deal of force and nothing should be in their way when they deploy. Front airbags in combination with properly worn safety belts slow down and limit the occupant's forward movement. Together they help to prevent the driver and front seat passenger from hitting parts of the inside the vehicle while reducing the forces acting on the occupant during the crash. In this way they help to reduce the risk of injury to the head and upper body in the crash. Airbags do not protect the arms or the lower parts of the body.

Both front airbags will not inflate in all frontal collisions. The triggering of the airbag system depends on the vehicle deceleration rate caused by the collision and registered by the electronic control unit. If this rate is below the reference value programmed into the control unit, the airbags will not be triggered, even though the car may be badly damaged as a result of the collision. Vehicle damage, ►

repair costs or even the lack of vehicle damage is not necessarily an indication of whether an airbag should inflate or not.

It is not possible to define a range of vehicle speeds that will cover every possible kind and angle of impact that will always trigger the airbags, since the circumstances will vary considerably between one collision and another. Important factors include, for example, the nature (hard or soft) of the object which the car hits, the angle of impact, vehicle speed, etc. The front airbags will also not inflate in side or rear collisions, or in roll-overs.

Always remember: Airbags will deploy only once, and only in certain kinds of collisions. Your safety belts are always there to offer protection in those situations in which airbags are not supposed to deploy, or when they have already deployed; for example, when your vehicle strikes or is struck by another after the first collision.

This is just one of the reasons why an airbag is a supplementary restraint and is not a substitute for a safety belt. The airbag system works most effectively when used with the safety belts. Therefore, always wear your safety belts properly ⇒ *page 116*.

WARNING

Sitting too close to the steering wheel or instrument panel will decrease the effectiveness of the airbags and will increase the risk of personal injury in a collision.

- **Never sit closer than 10 inches (25 cm) to the steering wheel or instrument panel.**
- **If you cannot sit more than 10 inches (25 cm) from the steering wheel, investigate whether adaptive equipment may be available to help you reach the pedals and increase your seating distance from the steering wheel.**
- **If you are unrestrained, leaning forward, sitting sideways or out of position in any way, your risk of injury is much higher.**
- **You will also receive serious injuries and could even be killed if you are up against the airbag or too close to it when it inflates - even with an Advanced Airbag.**

WARNING (continued)

- **To reduce the risk of injury when an airbag inflates, always wear safety belts properly ⇒ *page 120*, "How are safety belts worn correctly?"**.
- **Never let children ride unrestrained or improperly restrained in the vehicle. Adjust the front seats properly. If children are not properly restrained, they may be severely injured or killed when an airbag inflates.**
- **Never ride with the backrest reclined.**
- **Always sit as far as possible from the steering wheel or the instrument panel ⇒ *page 108*, "Proper occupant seating positions".**
- **Always sit upright with your back against the backrest of your seat.**
- **Never place your feet on the instrument panel or on the seat. Always keep both feet on the floor in front of the seat to help prevent serious injuries to the legs and hips if the airbag inflates.**
- **Never recline the front passenger's seat to transport objects. Items can also move into the area of the side airbag or the front airbag during braking or in a sudden maneuver. Objects near the airbags can become projectiles and cause injury when an airbag inflates.**

WARNING

Airbags that have deployed in a crash must be replaced.

- **Use only original equipment airbags approved by Audi and installed by a trained technician who has the necessary tools and diagnostic equipment to properly replace any airbag in your vehicle and assure system effectiveness in a crash.**
- **Never permit salvaged or recycled airbags to be installed in your vehicle. ■**

Child restraints on the front seat – some important things to know

- Be sure to read the important information and head the WARNINGS for important details about children and Advanced Airbags ⇒ *page 147*.

Even though your vehicle is equipped with an Advanced Airbag System, make certain that all children, especially those 12 years and younger, are properly restrained for their age and size. The airbag on the passenger side makes the front seat a potentially dangerous place for a child to ride. The front seat is not the safest place for a child in a forward-facing child safety seat. It can be a very dangerous place for an infant or a child in a rearward-facing seat.

The Advanced Airbag System in your vehicle has been certified to comply with the Requirements of United States Federal Motor Vehicle Safety Standard 208 as applicable at the time your vehicle was manufactured.

The Standard requires the front airbag on the passenger side to be turned off (“suppressed”) if a child up to about one year of age restrained in one of the rear-facing or forward-facing infant restraints listed in Federal Motor Vehicle Safety Standard 208 with which the Advanced Airbag System in your vehicle was certified has been installed on the front passenger seat. For a listing of the child restraints that were used to certify compliance with the US Safety Standard ⇒ *page 149*.

The **PASSENGER AIR BAG OFF** light in the instrument panel tells you when the front Advanced Airbag on the passenger side has been turned off by the electronic control unit.

Each time you turn on the ignition, the **PASSENGER AIR BAG OFF** light will come on for a few seconds and:

- will stay on if the front passenger seat is not occupied,
- will stay on if there is a small child or child restraint on the front passenger seat,

- will go off if the front passenger seat is occupied by an adult as registered by the weight-sensing mat ⇒ *page 136*, “Monitoring the Advanced Airbag System”.

The **PASSENGER AIR BAG OFF** light comes on when the control unit detects a total weight on the front passenger seat that requires the front airbag to be turned off.

If the total weight on the front passenger seat is more than that of a typical 1 year-old child but less than the weight of a small adult, the front airbag on the passenger side can deploy (the **PASSENGER AIR BAG OFF** light does not come on). If the **PASSENGER AIR BAG OFF** light does not come on, the front airbag on the passenger side has not been turned off by the electronic control unit and can deploy if the control unit senses an impact that meets the conditions stored in its memory.

For example, the airbag may deploy if:

- a small child that is heavier than a typical 1 year-old child is on the front passenger seat (regardless of whether the child is in one of the child safety seats listed ⇒ *page 149*), or
- a child who has outgrown child restraints is on the front passenger seat.

If the front passenger airbag is turned off, the **PASSENGER AIR BAG OFF** light in the center of the instrument panel will come on and stay on.

The front airbag on the passenger side may *not* deploy (the **PASSENGER AIR BAG OFF** light does not illuminate and stay lit) even if a small adult or teenager, or a passenger who is not sitting upright with their back against a non-reclined backrest with their feet on the vehicle floor in front of the seat is on the front passenger seat ⇒ *page 108*, “Proper seating position for the driver”.

If the front passenger airbag deploys, the Federal Standard requires the airbag to meet the “low risk” deployment criteria to reduce the risk of injury through interaction with the airbag. “Low risk” deployment occurs in those crashes that take place at lower decelerations ►

as defined in the electronic control unit ⇒ *page 137, "PASSENGER AIR BAG OFF light"*.

Always remember, a child safety seat or infant carrier installed on the front seat may be struck and knocked out of position by the rapidly inflating passenger's airbag in a frontal collision. The airbag could greatly reduce the effectiveness of the child restraint and even seriously injure the child during inflation.

WARNING

A child in a rearward-facing child safety seat installed on the front passenger seat will be seriously injured and can be killed if the front airbag inflates - even with an Advanced Airbag System.

- The inflating airbag will hit the child safety seat or infant carrier with great force and will smash the child safety seat and child against the backrest, door or roof.
- Never install a rearward facing child safety seat on the front passenger seat unless the PASSENGER AIR BAG OFF light comes on and stays on. If the PASSENGER AIR BAG OFF light does not come on and stay on the inflating airbag will hit the child safety seat or infant carrier with great force and will smash the child safety seat and child against the backrest, door or roof. Have the airbag system inspected immediately by your authorized Audi dealer.
- Forward-facing child safety seats installed on the front passenger's seat may interfere with the deployment of the airbag and cause serious personal injury to the child.

WARNING

If, in exceptional circumstances, you must install a forward-facing child restraint on the front passenger's seat:

- Always make sure the forward-facing seat has been designed and certified by its manufacturer for use on a front seat with a passenger front and side airbag.

WARNING (continued)

- **Never put the forward-facing child restraint up against or very near the instrument panel.**
- **Always move the passenger seat into its rearmost position in the seat's fore and aft adjustment range, as far away from the airbag as possible before installing the forward-facing child restraint. The backrest must be adjusted to an upright position.**
- **Make sure that the PASSENGER AIR BAG OFF light comes on and stays on all the time whenever the ignition is switched on.**

WARNING

To reduce the risk of serious injury, make sure that the PASSENGER AIR BAG OFF light will be displayed whenever a child restraint is installed on the front passenger seat and the ignition is switched on.

- **If the PASSENGER AIR BAG OFF light does not stay on, perform the checks described ⇒ *page 136, "Monitoring the Advanced Airbag System"*.**
- **Never install a rearward facing child safety seat on the front passenger seat unless the PASSENGER AIR BAG OFF light comes on and stays on. If the PASSENGER AIR BAG OFF light does not come on and stay on, the inflating airbag will hit the child safety seat or infant carrier with great force and will smash the child safety seat and child against the backrest, door or roof. Have the airbag system inspected immediately by your authorized Audi dealer.**
- **Always carefully follow instructions from child restraint manufacturers when installing child restraints.**

WARNING

If, in exceptional circumstances, you must install a forward or rearward-facing child restraint on the front passenger's seat:

! WARNING (continued)

- Improper installation of child restraints can reduce their effectiveness or even prevent them from providing any protection.
- An improperly installed child restraint can interfere with the airbag as it deploys and seriously injure or even kill the child – even with an Advanced Airbag System.
- Always follow the manufacturer's instructions provided with the child safety seat or carrier carefully.
- Never place additional items on the seat that can increase the total weight registered by the weight-sensing mat and can cause injury in a crash. ■

Front airbags

Description of front airbags

The airbag system can provide supplemental protection to properly restrained front seat occupants.



Fig. 99 Location of driver airbag: in steering wheel



Fig. 100 Location of front passenger's airbag: in the instrument panel

Your vehicle is equipped with an "Advanced Airbag System" in compliance with United States Federal Motor Vehicle Safety Standard (FMVSS) 208 as applicable at the time your vehicle was manufactured. The safety belts for the front seats have "pretensioners" that help to take slack out of the belt system. The pretensioners are also activated by the electronic control unit for the airbag system.

The front safety belts also have load limiters to help reduce the forces applied to the body in a crash.

The airbag for the driver is in the steering wheel hub ⇒ fig. 99 and the airbag for the front passenger is in the instrument panel ⇒ fig. 100. The general location of the airbags is marked "AIRBAG".

There is a lot you need to know about the airbags in your vehicle. We urge you to read the detailed information about airbags, safety belts and child safety in this and the other chapters that make up the owner's literature. Please be sure to heed the WARNINGS - they are extremely important for your safety and the safety of your passengers, especially infants and small children.

! WARNING

Never rely on airbags alone for protection.

- **Even when they deploy, airbags provide only supplemental protection.**

⚠ WARNING (continued)

- Airbag work most effectively when used with properly worn safety belts.
- Therefore, always wear your safety belts and make sure that everybody in your vehicle is properly restrained.

⚠ WARNING

A person on the front passenger seat, especially infants and small children, will receive serious injuries and can even be killed by being too close to the airbag when it inflates.

- Although the Advanced Airbag System in your vehicle is designed to turn off the front passenger airbag if an infant or a small child is on the front passenger seat, nobody can absolutely guarantee that deployment under these special conditions is impossible in all conceivable situations that may happen during the useful life of your vehicle.
- The Advanced Airbag System can deploy in accordance with the "low risk" option under the U.S. Federal Standard if a child that is heavier than the typical one-year old child is on the front passenger seat and the other conditions for airbag deployment are met.
- For their own safety, all children, especially 12 years and younger, should always ride properly restrained for their age and size. ■

Advanced front airbag system

Your vehicle is equipped with a front Advanced Airbag System in compliance with United States Federal Motor Vehicle Safety Standard 208 as applicable at the time your vehicle was manufactured.

The front Advanced Airbag System supplements the safety belts to provide additional protection for the driver's and front passenger's

heads and upper bodies in frontal crashes. The airbags inflate only in frontal impacts when the vehicle deceleration is high enough.

The front Advanced Airbag System for the front seat occupants is not a substitute for your safety belts. Rather, it is part of the overall occupant restraint system in your vehicle. Always remember that the airbag system can only help to protect you, if you are sitting upright, wearing your safety belt and wearing it properly. This is why you and your passengers must always be properly restrained, not just because the law requires you to be.

The Advanced Airbag System in your vehicle has been certified to meet the "low risk" requirements for 3 and 6 year-old children on the passenger side and very small adults on the driver side. The low risk deployment criteria are intended to help reduce the risk of injury through interaction with the front airbag that can occur, for example, by being too close to the steering wheel and instrument panel when the airbag inflates.

In addition, the system has been certified to comply with the "suppression" requirements of the Safety Standard, to turn off the front airbag for infants 12 months old and younger who are restrained on the front passenger seat in child restraints that are listed in the Standard ⇒ *page 149*, "Child restraints and Advanced Airbags".

"Suppression" requires the front airbag on the passenger side to be turned off if:

- a child up to about one year of age is restrained on the front passenger seat in one of the rear-facing or forward-facing infant restraints listed in Federal Motor Vehicle Safety Standard 208 with which the Advanced Airbag System in your vehicle was certified. For a listing of the child restraints that were used to certify your vehicle's compliance with the US Safety Standard ⇒ *page 149*,
- weight less than a threshold level stored in the control unit is detected on the front passenger seat.

When a person is detected on the front passenger seat, weighing more than the total weight of a child that is about 1 year old restrained in one of the rear-facing or forward-facing infant

restraints (listed in Federal Motor Vehicle Safety Standard 208 with which the Advanced Airbag System in your vehicle was certified), the front airbag on the passenger side may or may not deploy.

The **PASSENGER AIR BAG OFF** light comes on when the electronic control unit detects a total weight on the front passenger seat that requires the front airbag to be turned off. If the **PASSENGER AIR BAG OFF** light does not come on, the front airbag on the passenger side has not been turned off by the control unit and can deploy if the control unit senses an impact that meets the conditions stored in its memory.

If the total weight on the front passenger seat is more than that of a typical 1 year-old, but less than the weight of a small adult, the front airbag on the passenger side may deploy (the **PASSENGER AIR BAG OFF** light does not come on).

For example, the airbag may deploy if:

- a small child that is heavier than a typical 1 year-old child is on the front passenger seat (regardless of whether the child is in one of the child safety seats listed ⇒ *page 149*),
- a child who has outgrown child restraints is on the front passenger seat.

If the front passenger airbag is turned off, the **PASSENGER AIR BAG OFF** light in the center of the instrument panel will come on and stay on.

The front airbag on the passenger side may *not* deploy (the **PASSENGER AIR BAG OFF** light does not illuminate and stay lit) if:

- a small adult or teenager is on the front passenger seat
- a passenger who is not sitting upright with their back against a non-reclined backrest with their feet on the vehicle floor in front of the seat is on the front passenger seat.

If the front passenger airbag deploys, the Federal Standard requires the airbag to meet the “low risk” deployment criteria to help reduce the risk of injury through interaction with the airbag. “Low risk” deployment occurs in those crashes that take place at lower decelerations as defined in the electronic control unit ⇒ *page 136*.

Please be sure to read the important information in the sections that follow and be sure to heed all of the WARNINGS.

WARNING

To reduce the risk of injury when an airbag inflates, always wear safety belts properly.

- If you are unrestrained, leaning forward, sitting sideways or out of position in any way, your risk of injury is much higher.
- You will also receive serious injuries and could even be killed if you are up against the airbag or too close to it when it inflates - even with an Advanced Airbag ⇒ *page 125*.

WARNING

A child in a rearward-facing child safety seat installed on the front passenger seat will be seriously injured and can be killed if the front airbag inflates - even with an Advanced Airbag System.

- Although the Advanced Airbag System in your vehicle is designed to turn off the front airbag when a rearward-facing child restraint has been installed on the front passenger seat, nobody can absolutely guarantee that deployment is impossible in all conceivable situations that may happen during the useful life of your vehicle.
- The inflating airbag will hit the child safety seat or infant carrier with great force and will smash the child safety seat and child against the backrest, door, or roof.
- Never install a rearward facing child safety seat on the front passenger seat unless the **PASSENGER AIR BAG OFF** light comes on and stays on. If the **PASSENGER AIR BAG OFF** light does not come on and stay on the inflating airbag will hit the child safety seat or infant carrier with great force and will smash the child safety seat and child against the backrest, door or roof. Have the airbag system inspected immediately by your authorized Audi dealer.

 **WARNING**

If, in exceptional circumstances, you must install a forward-facing child restraint on the front passenger's seat:

- Always make sure the forward-facing seat has been designed and certified by its manufacturer for use on a front seat with a passenger front and side airbag.
- Never put the forward-facing child restraint up against or very near the instrument panel.
- Always move the passenger seat into its rearmost position in the seat's fore and aft adjustment range, as far away from the airbag as possible, before installing the forward-facing child restraint. The backrest must be adjusted to an upright position.
- Make sure that the **PASSENGER AIR BAG OFF** light comes on and stays on all the time whenever the ignition is switched on. ■

Advanced Airbag System components

The front passenger seat in your vehicle has a lot of very important parts of the Advanced Airbag System in it. These parts include the weight-sensing mat, sensors, wiring, brackets, and more. The function of the system in the front passenger seat is checked by the electronic control unit when the ignition is on. The control unit monitors the Advanced Airbag System and turns the airbag indicator light on when a malfunction in the system components is detected. The function of the airbag indicator light is described in greater detail below. Because the front passenger seat contains important parts of the Advanced Airbag System, you must take care to prevent it from being damaged. Damage to the seat may prevent the Advanced Airbag for the front passenger seat from doing its job in a crash.

The front Advanced Airbag System consists of the following:

- Crash sensors in the front of the vehicle that measure vehicle acceleration/deceleration to provide information to the Advanced Airbag System about the severity of the crash.
- An electronic control unit, with integrated crash sensors for front and side impacts. The control unit "decides" whether to fire the front airbags based on the information received from the crash sensors. The control unit also "decides" whether the safety belt pretensioners should be activated.
- An Advanced Airbag with gas generator for the driver inside the steering wheel hub.
- An Advanced Airbag with gas generator inside the instrument panel for the front passenger.
- A weight-sensing mat under the upholstery padding of the front passenger seat cushion that measures the total weight on the seat. The information registered is sent continuously to the electronic control unit to regulate deployment of the front Advanced Airbag on the passenger side.
- An airbag monitoring system and indicator light in the instrument cluster ⇒ *page 136*.
- The **PASSENGER AIR BAG OFF** light comes on and stays on in the center of the instrument panel ⇒ *page 137*, fig. 102 and tells you when the front Advanced Airbag on the passenger side has been turned off.
- A sensor below the safety belt latch for the front seat passenger to measure the tension on the safety belt. The tension on the safety belt and the weight registered by the weight-sensing mat help the control unit "decide" whether the front airbag for the front passenger seat should be turned off or not ⇒ *page 127*, "Child restraints on the front seat – some important things to know".
- A sensor in the safety belt latch for the driver and for the front seat passenger that senses whether that safety belt is latched or not and transmits this information to the electronic control unit. ►

 **WARNING**

Damage to the front passenger seat can prevent the front airbag from working properly.

- Improper repair or disassembly of the front passenger and driver seat will prevent the Advanced Airbag System from functioning properly.
- Repairs to the front passenger seat must be performed by qualified and properly trained workshop personnel.
- Never remove the front passenger or driver seat from the vehicle.
- Never remove the upholstery from the front passenger seat.
- Never disassemble or remove parts from the seat or disconnect wires from it.
- Never carry sharp objects in your pockets or place them on the seat. If the weight-sensing mat in the passenger seat is punctured it cannot work properly.
- Never carry things on your lap or carry objects on the passenger seat. Such items can increase the weight registered by the weight-sensing mat and send the wrong information to the airbag control unit.
- Never store items under the front passenger seat. Parts of the Advanced Airbag System under the passenger seat could be damaged, preventing them and the airbag system from working properly.
- Never place seat covers or replacement upholstery that have not been specifically approved by Audi on the front seats.
- Seat covers can prevent the Advanced Airbag System from recognizing child restraints or occupants on the front passenger seat and prevent the side airbag in the seat backrest from deploying properly.
- Never use cushions, pillows, blankets or similar items on the front passenger seat. The additional padding will prevent the weight-sensing mat in the seat from accurately registering the

 **WARNING (continued)**

child restraint or person on the seat and prevent the Advanced Airbag System from functioning properly.

- If you must use a child restraint on the front passenger seat and the child restraint manufacturer's instructions require the use of a towel, foam cushion or something else to properly position the child restraint, make certain that the PASSENGER AIR BAG OFF light comes on and stays on whenever the child restraint is installed on the front passenger seat.
- If the PASSENGER AIR BAG OFF light does not come on and stay on, the inflating airbag will hit the child safety seat or infant carrier with great force and will smash the child safety seat and child against the backrest, door or roof. Have the airbag system inspected immediately by your authorized Audi dealer. ■

How the Advanced Airbag System components work together

The front Advanced Airbag System and the side airbags supplement the protection offered by the front three-point safety belts with pretensioners and load limiters and the adjustable head restraints to help reduce the risk of injury in a wide range of accident and crash situations. Be sure to read the important information about safety and heed the WARNINGS in this chapter.

Deployment of the Advanced Airbag System and the activation of the safety belt pretensioners depend on the deceleration measured by the crash sensors and registered by the electronic control unit. Crash severity depends on speed and deceleration as well as the mass and stiffness of the vehicle or object involved in the crash.

When the electronic control unit registers a low severity crash and the safety belt is being used, the airbag will not deploy. If the safety belt is not being used, the first stage deploys, followed by the second stage after a much later time in the crash sequence. ►

If the electronic control unit registers a crash of medium severity, the first stage of the airbag deploys followed by the second stage at a much later time in the crash sequence - regardless of whether the safety belt is being used or not. In higher severity crashes as registered by the electronic control unit, both the first and second stages deploy almost at the same time.

On the passenger side, regardless of safety belt use, the airbag will be turned off if the weight on the passenger seat is less than the amount programmed in the electronic control unit. The front airbag on the passenger side will also be turned off if one of the child safety seats that has been certified under Federal Motor Vehicle Safety Standard 208 has been recognized on the seat. The **PASSENGER AIR BAG OFF** light comes on and stays on to tell you when the front Advanced Airbag on the passenger side has been turned off ⇒ *page 127*, "Child restraints on the front seat – some important things to know".

WARNING

To reduce the risk of injury when an airbag inflates, always wear safety belts properly.

- **If you are unrestrained, leaning forward, sitting sideways or out of position in any way, your risk of injury is much higher.**
- **You will also receive serious injuries and could even be killed if you are up against the airbag or too close to it when it inflates - even with an Advanced Airbag ⇒ *page 125*. ■**

More important things to know about front airbags



Fig. 101 Inflated front airbags

Safety belts are important to help keep front seat occupants in the proper seated position so that airbags can deploy properly and provide supplemental protection in a frontal collision.

The front airbags are designed to provide additional protection for the chest and face of the driver and the front seat passenger when:

- safety belts are worn properly,
- the seats have been positioned so that the occupant is properly seated as far as possible from the airbag,
- and the head restraints have been properly adjusted.

Because airbags inflate in the blink of an eye with great force, things you have on your lap or have placed on the seat could become dangerous projectiles, and be pushed into you if the airbag inflates.

When an airbag deploys, fine dust is released. This is normal and is not caused by a fire in the vehicle. This dust is made up mostly of a powder used to lubricate the airbags as they deploy. It could irritate skin.

It is important to remember that while the supplemental airbag system is designed to reduce the likelihood of serious injuries, other injuries, for example swelling, bruising and minor abrasions, can also happen when airbags inflate. Airbags do not protect the arms ►

or the lower parts of the body. Front airbags only supplement the three point safety belts in some frontal collisions in which the vehicle deceleration is high enough to deploy the airbags.

Front airbags will not deploy:

- if the ignition is switched off when a crash occurs,
- in side collisions,
- in rear-end collisions,
- in rollovers,
- when the crash deceleration measured by the airbag system is less than the minimum threshold needed for airbag deployment as registered by the electronic control unit.

The front passenger airbag will also not deploy:

- when the front passenger seat is not occupied,
- when the weight on the front passenger seat as sensed by the Advanced Airbag System indicates that the front airbag on the passenger side has to be turned off by the electronic control unit (the **PASSENGER AIR BAG OFF** light comes on and stays on).

WARNING

Sitting in the wrong position can increase the risk of serious injury in crashes.

- **To reduce the risk of injury when the airbags inflate, the driver and passengers must always sit in an upright position, must not lean against or place any part of their body too close to the area where the airbags are located.**
- **Occupants who are unbelted, out of position or too close to the airbag can be seriously injured by an airbag as it unfolds with great force in the blink of an eye ⇒ page 127.**

WARNING

A child in a rearward-facing child safety seat installed on the front passenger seat will be seriously injured and can be killed if the front airbag inflates - even with an Advanced Airbag System.

- **The inflating airbag will hit the child safety seat or infant carrier with great force and will smash the child safety seat and child against the backrest, center arm rest, door or roof.**
- **Never install a rearward facing child safety seat on the front passenger seat unless the **PASSENGER AIR BAG OFF** light comes on and stays on. If the **PASSENGER AIR BAG OFF** light does not come on and stay on, the inflating airbag will hit the child safety seat or infant carrier with great force and will smash the child safety seat and child against the backrest, door or roof. Have the airbag system inspected immediately by your authorized Audi dealer.**

WARNING

Objects between you and the airbag will increase the risk of injury in a crash by interfering with the way the airbag unfolds or by being pushed into you as the airbag inflates.

- **Never hold things in your hands or on your lap when the vehicle is in use.**
- **Never transport items on or in the area of the front passenger seat. Objects could move into the area of the front airbags during braking or other sudden maneuver and become dangerous projectiles that can cause serious personal injury if the airbags inflate.**
- **Never place or attach accessories or other objects (such as cup holders, telephone brackets, large, heavy or bulky objects) on the doors, over or near the area marked "AIRBAG" on the steering wheel, instrument panel, seat backrests or between those areas and yourself. These objects could cause injury in a crash, especially when the airbags inflate.**

⚠ WARNING (continued)

- Never recline the front passenger's seat to transport objects. Items can also move into the area of the side airbag or the front airbag during braking or in a sudden maneuver. Objects near the airbags can become projectiles and cause injury, particularly when the seat is reclined.

⚠ WARNING

The fine dust created when airbags deploy can cause breathing problems for people with a history of asthma or other breathing conditions.

- To reduce the risk of breathing problems, those with asthma or other respiratory conditions should get fresh air right away by getting out of the vehicle or opening windows or doors.
- If you are in a collision in which airbags deploy, wash your hands and face with mild soap and water before eating.
- Be careful not to get the dust into your eyes, or into any cuts or scratches.
- If the residue should get into your eyes, flush them with water. ■

Monitoring the Advanced Airbag System

Airbag monitoring indicator light

Two separate indicators monitor the function of the Advanced Airbag System: the airbag monitoring indicator light and the **PASSENGER AIR BAG OFF** light.

The Advanced Airbag System (including the electronic control unit, sensor circuits and system wiring) is monitored continuously to make sure that it is functioning properly whenever the ignition is on.

Each time you turn on the ignition, the airbag monitoring indicator light  will come on for a few seconds (self diagnostics).

The system must be inspected when the indicator light :

- does not come on when the ignition is switched on,
- does not go out a few seconds after you have switched on the ignition, or
- comes on while driving.

If an airbag system malfunction is detected, the indicator light will first start flashing to catch the driver's attention and then stay on continuously to serve as a constant reminder to have the system inspected immediately.

If a malfunction occurs that turns the front airbag on the passenger side off, the **PASSENGER AIR BAG OFF** light will come on and stay on whenever the ignition is on.

⚠ WARNING

An airbag system that is not functioning properly cannot provide supplemental protection in a frontal crash.

- If the airbag indicator light comes on, it means that there may be something wrong with the Advanced Airbag System. It is possible that the airbag will inflate when it is not supposed to, or will not inflate when it should.
- Have the airbag system inspected immediately by your authorized Audi dealer. ■

PASSENGER AIR BAG OFF light



Fig. 102 Section from the instrument panel: PASSENGER AIR BAG OFF light

The **PASSENGER AIR BAG OFF** light is located in the center of the instrument panel ⇒ fig. 102.

The **PASSENGER AIR BAG OFF** light will come on and stay on to tell you when the front Advanced Airbag on the passenger side has been turned off by the electronic control unit. Each time you turn on the ignition, the **PASSENGER AIR BAG OFF** light will flash for a few seconds and:

- will stay on if the front passenger seat is not occupied,
- will stay on if there is a small child or child restraint on the front passenger seat,
- will go out if the front passenger seat is occupied by an adult as registered by the weight-sensing mat.

The **PASSENGER AIR BAG OFF** light must come on and stay on if the ignition is on and

- a car bed has been installed on the front seat, or
- a rearward-facing child restraint has been installed on the front passenger seat, or
- a forward-facing child restraint has been installed on the front passenger seat, or
- the weight registered on the front passenger seat is equal to or less than the combined weight of a typical 1 year-old restrained in

one of the rear-facing or forward-facing infant restraints listed in Federal Motor Vehicle Safety Standard 208 with which the Advanced Airbag System in your vehicle was certified.

If the front passenger seat is not occupied, the front airbag will not deploy, and the **PASSENGER AIR BAG OFF** light will stay on. Never install a rearward-facing child restraint on the front passenger seat ⇒ *page 127*, "Child restraints on the front seat – some important things to know" and ⇒ *page 147*, "Child Safety".

If the **PASSENGER AIR BAG OFF** light comes on when one of the conditions listed above is met, be sure to check the light regularly to make certain that the **PASSENGER AIR BAG OFF** light stays on continuously whenever the ignition is on. If the **PASSENGER AIR BAG OFF** light does not appear and stay on all the time, stop as soon as it is safe to do so and

- reactivate the system by turning the ignition off and then turning it on again;
- remove and reinstall the child restraint. Make sure that the child restraint is properly installed and that the safety belt for the front passenger seat has been correctly routed around the child restraint as described in the child restraint manufacturer's instructions;
- make sure that the convertible locking feature on the safety belt for the front passenger seat has been activated and that the safety belt has been pulled tight. The belt must not be loose or have loops of slack so that the sensor below the safety belt latch on the seat can do its job ⇒ *page 156*;
- make sure that things that may increase the weight of the child and child safety seat are not being transported on the front passenger seat;
- make sure that the safety belt tension sensor is not blocked. Shake the safety belt latch on the front passenger seat back and forth;
- If a strap or tether is being used to tie the child safety seat to the front passenger seat, make sure that it is not so tight that it causes the weight-sensing mat to measure more weight than is actually on the seat. ▶

If the **PASSENGER AIR BAG OFF** light still does not come on and does not stay on continuously (when the ignition is switched on),

- take the child restraint off the front passenger seat and have the airbag system inspected by your authorized Audi dealer. Do not transport children without a child safety seat.

The **PASSENGER AIR BAG OFF** light should NOT come on when the ignition is on and an adult is sitting in a proper seating position on the front passenger seat. If the **PASSENGER AIR BAG OFF** light comes on and stays on or flashes for about 5 seconds while driving, under these circumstances, make sure that:

- the adult on the front passenger seat is properly seated on the center of the seat cushion with his or her back up against the backrest and the backrest is not reclined ⇒ *page 108, "Proper occupant seating positions"*,
- the adult is not taking weight off the seat by holding on to the passenger assist handle above the front passenger door or supporting their weight on the armrest,
- the safety belt is being properly worn and that there is not a lot of slack in the safety belt webbing,
- accessory seat covers or cushions or other things that may cause an incorrect reading or impression on the weight-sensing mat under the upholstery of the seat have been removed from the front passenger seat,
- a safety belt extender has not been left in the safety belt latch for the front passenger seat.

In addition to the **PASSENGER AIR BAG OFF** light in the center of the instrument panel, the message **PASSENGER AIR BAG OFF** or **PASSENGER AIR BAG ON** will briefly appear in the instrument cluster display. This is to inform the driver of the current front passenger airbag status. ■

Important safety instructions on monitoring the Advanced Airbag System

WARNING

An airbag system that is not functioning properly cannot provide supplemental protection in a frontal crash.

- If the airbag indicator light comes on, it means that there may be something wrong with the Advanced Airbag System. It is possible that the airbag will inflate when it is not supposed to, or will not inflate when it should.
- Have the airbag system inspected immediately by your authorized Audi dealer.

WARNING

If the front airbag inflates, a child without a child restraint, in a rearward-facing child safety seat or in a forward-facing child restraint that has not been properly installed will be seriously injured and can be killed.

- Even though your vehicle is equipped with an Advanced Airbag System, make certain that all children, especially 12 years and younger, always ride properly restrained for their age and size.
- Never install a rearward facing child safety seat on the front passenger seat unless the **PASSENGER AIR BAG OFF** light comes on and stays on. If the **PASSENGER AIR BAG OFF** light does not come on and stay, on the inflating airbag will hit the child safety seat or infant carrier with great force and will smash the child safety seat and child against the backrest, door or roof. Have the airbag system inspected immediately by your authorized Audi dealer.
- A tight tether or other strap on a rearward-facing child restraint attached to the front passenger seat can put too much pressure on the weight-sensing mat in the seat and register more weight than is actually on the seat. The heavier weight registered can

 **WARNING (continued)**

make the system work as though an adult were on the seat and deploy the Advanced Airbag when it must be suppressed, causing serious or even fatal injury to the child.

- If, in exceptional circumstances, you must install a forward-facing child restraint on the front passenger seat, always move the seat into its rearmost position in the seat's fore and aft adjustment range, as far away from the airbag as possible. The backrest must be adjusted to an upright position. Make sure that the PASSENGER AIR BAG OFF light comes on and stays on all the time whenever the ignition is switched on.

 **WARNING**

- If the PASSENGER AIR BAG OFF light does not go out when an adult is sitting on the front passenger seat after taking the steps described above, have the airbag system inspected by your authorized Audi dealer before transporting anyone on the front passenger seat.

 **Tips**

If the weight-sensing mat in the front passenger seat detects an empty seat, the front airbag on the passenger side will be turned off, and PASSENGER AIR BAG OFF will stay on. ■

Care, service and disposal of the airbags

Parts of the airbag system are installed at many different places on your Audi. Installing, removing, servicing or repairing a part in an area of the vehicle can damage a part of an airbag system and prevent that system from working properly in a collision.

There are some important things you have to know to make sure that the effectiveness of the system will not be impaired and that

discarded components do not cause injury or pollute the environment.

 **WARNING**

Improper care, servicing and repair procedures can increase the risk of personal injury and death by preventing an airbag from deploying when needed or deploying an airbag unexpectedly:

- Never cover, obstruct, or change the steering wheel horn pad or airbag cover or the instrument panel or modify them in any way.
- Never attach any objects such as cup holders or telephone mountings to the surfaces covering the airbag units.
- For cleaning the horn pad or instrument panel, use only a soft, dry cloth or one moistened with plain water. Solvents or cleaners could damage the airbag cover or change the stiffness or strength of the material so that the airbag cannot deploy and protect properly.
- Never repair, adjust, or change any parts of the airbag system.
- All work on the steering wheel, instrument panel, front seats or electrical system (including the installation of audio equipment, cellular telephones and CB radios, etc.) must be performed by a qualified technician who has the training and special equipment necessary.
- For any work on the airbag system, we strongly recommend that you see your authorized Audi dealer or qualified workshop.
- Never modify the front bumper or parts of the vehicle body.
- Always make sure that the side airbag can inflate without interference:
 - Never install seat covers or replacement upholstery over the front seatbacks that have not been specifically approved by Audi.
 - Never use additional seat cushions that cover the areas where the side airbags inflate.

 **WARNING** (continued)

- **Damage to the original seat covers or to the seam in the area of the side airbag module must always be repaired immediately by an authorized Audi dealer.**
- **The airbag system can be activated only once. After an airbag has inflated, it must be replaced by an authorized Audi dealer or qualified technician who has the technical information, training and special equipment necessary.**
- **The airbag system can be deployed only once. After an airbag has been deployed, it must be replaced with new replacement parts designed and approved especially for your Audi model version. Replacement of complete airbag systems or airbag components must be performed by qualified workshops only. Make sure that any airbag service action is entered in your Audi Warranty & Maintenance booklet under *AIRBAG REPLACEMENT RECORD*.**
- **For safety reasons in severe accidents, the alternator and starter are separated from the vehicle battery with a pyrotechnic circuit interrupter.**
 - **Work on the pyrotechnic circuit interrupter must only be performed by a qualified dealer - risk of an accident!**
 - **If the vehicle or the circuit interrupter is scrapped, all applicable safety precautions must be followed.**

**For the sake of the environment**

Undeployed airbag modules and pretensioners might be classified as Perchlorate Material -special handling may apply, see www.dtsc.ca.gov/hazardouswaste/perchlorate. When the vehicle or parts of the restraint system including airbag modules safety belts with pretensioners are scrapped, all applicable laws and regulations must be observed. Your authorized Audi dealer is familiar with these requirements and we recommend that you have your dealer perform this service for you. ■

Other things that can affect Advanced Airbag performance

Changing the vehicle's suspension system can change the way that the Advanced Airbag System performs in a crash. For example, using tire-rim combinations not approved by Audi, lowering the vehicle, changing the stiffness of the suspension, including the springs, suspension struts, shock absorbers etc. can change the forces that are measured by the airbag sensors and sent to the electronic control unit. Some suspension changes can, for example, increase the force levels measured by the sensors and make the airbag system deploy in crashes in which it would not deploy if the changes had not been made. Other kinds of changes may reduce the force levels measured by the sensors and prevent the airbag from deploying when it should.

The sensors in the safety belt buckle for the driver and front passenger seat tell the electronic control module if the safety belt is latched or not. If the safety belt is being used, the front airbag will deploy at a slightly higher rate of vehicle deceleration than if the safety belt is not being used. Therefore, in a particular collision, it is possible that an airbag will not deploy at a seating position where the safety belt is being used but will inflate at the position where the safety belt is not being used. It is important that nothing interfere with the safety belt buckles so that the sensors can send the correct information about safety belt use to the electronic control unit.

 **WARNING**

Changing the vehicle's suspension including use of unapproved tire-rim combinations can change Advanced Airbag performance and increase the risk of serious personal injury in a crash.

- **Never install suspension components that do not have the same performance characteristics as the components originally installed on your vehicle.**
- **Never use tire-rim combinations that have not been approved by Audi.**

WARNING

Items stored between the safety belt buckle and the center console can cause the sensors in the buckle to send the wrong information to the electronic control module and prevent the Advanced Airbag System from working properly.

- Always make sure that nothing can interfere with the safety belt buckles and that they are not obstructed.

For the sake of the environment

Undeployed airbag modules and pretensioners might be classified as Perchlorate Material -special handling may apply, see www.dtsc.ca.gov/hazardouswaste/perchlorate. When the vehicle or parts of the restraint system including airbag modules safety belts with pretensioners are scrapped, all applicable laws and regulations must be observed. Your authorized Audi dealer is familiar with these requirements and we recommend that you have your dealer perform this service for you. ■

Knee airbags

Description of knee airbags

The airbag system can provide supplemental protection to properly restrained front seat occupants.

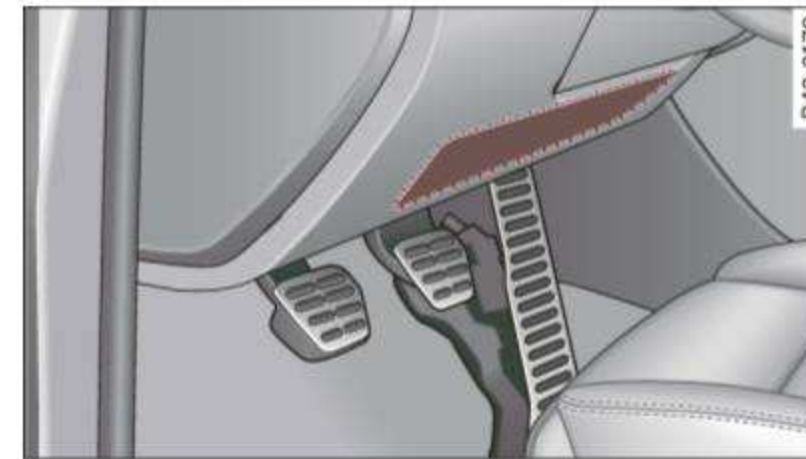

Fig. 103 Driver's airbag

The airbag for the driver is located in the instrument panel underneath the steering wheel ⇒ fig. 103, the airbag for the passenger is at about the same height in the instrument panel underneath the glove compartment.

The knee airbag offers additional protection to the driver's and passenger's knees and upper and lower thigh areas as a supplement to the safety belts.

If the front airbags deploy, the knee airbags also deploy in frontal collisions above a certain severity ⇒ *page 134*, "More important things to know about front airbags".

Besides their normal safety function, safety belts work to help keep the driver or front passenger in position in case of a frontal collision so that the airbags can provide protection.

The airbag system is not a substitute for your safety belt. Rather, it is part of the overall occupant restraint system in your vehicle. Always remember that the airbag system can only help to protect you if you are wearing your safety belt and wearing it properly. This ►

is why you should always wear your safety belt, not just because the law requires you to do so ⇒ *page 117, "Why safety belts?"*.

The safety belt buckle for the driver and front seat passenger have switches that tell the airbag control module if the safety belt is being used or not. If the safety belt is being used, the knee airbag will deploy at a slightly higher rate of deceleration than if the belt is not being used. Therefore, in a particular collision, it is possible that an airbag will not deploy at a seating position where the safety belt is being used but will inflate at the position where the safety belt is not being used.

Remember too, airbags will deploy only once and only in certain kinds of accidents - your safety belts are always there to offer protection in those accidents in which airbags are not supposed to deploy or when they have already deployed, for example when your vehicle strikes or is struck by another after the first collision.

This is just one of the reasons why an airbag is not a substitute for the safety belt. The airbag system works most effectively when used with the safety belts. Therefore, always wear your safety belts correctly.

It is important to remember that while the supplemental airbag system is designed to reduce the likelihood of serious injuries, other injuries, for example, swelling, bruising, and minor abrasions can also be associated with airbags.

The knee airbag system basically consists of:

- The electronic control module
- Two inflatable airbags (airbag and gas generator), one for the driver and one for the front passenger
- The airbag indicator light in the instrument panel

The knee airbag system will not deploy:

- when the ignition is turned off
- in front-end collisions when the deceleration measured by the control unit is too low
- in side collisions

- in rear-end collisions
- in rollovers
- in the event of a system malfunction (warning/indicator light illuminated) ⇒ *page 19*.



WARNING

- **Safety belts and the airbag system can only provide protection when occupants are in the proper seating position ⇒ *page 134*.**
- **If the airbag indicator light comes on when the vehicle is being used, have the system inspected immediately by your authorized Audi dealer. The airbag may not work properly when the vehicle acceleration in a side collision is high enough to deploy the airbag. See also ⇒ *page 19*. ■**

How knee airbags work

The risk of injury to the leg area is reduced by fully deployed knee airbags.

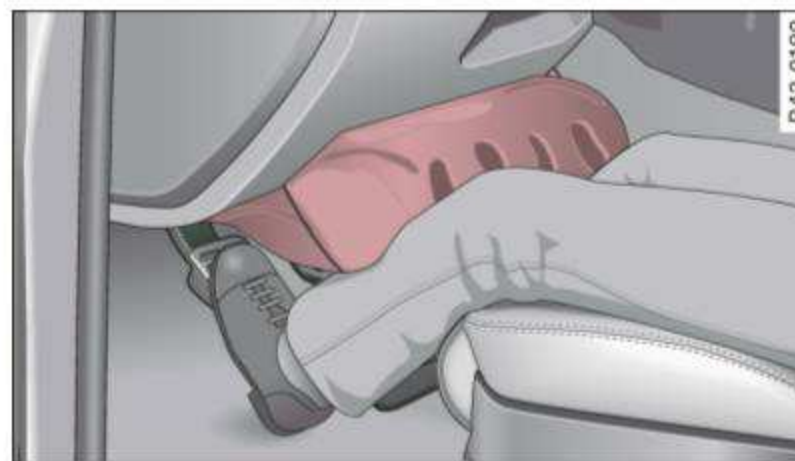

Fig. 104 Inflated airbags protecting in a frontal collision

The knee airbag system has been designed so that the airbags for the driver and front passenger are deployed in certain but not all frontal collisions. ▶

If the front airbags deploy, the knee airbags also deploy in frontal collisions above a certain severity.

When the system is deployed, the airbags start to fill with a propellant gas, and inflate between the lower part of the instrument panel and the driver and the lower part of the instrument panel and the front passenger ⇒ *page 134, fig. 101.*

Although they are not a soft pillow, they can “cushion” the impact and in this way they can help to reduce the risk of injury to the lower extremities.

All this takes place instantaneously, so fast that many people don't even realize that the airbags have deployed. The airbags also inflate with a great deal of force and it is important for occupant safety that nothing should be in their way when they deploy.

Fully inflated airbags in combination with properly worn safety belts slow down and limit the occupant's forward movement and help to reduce the risk. ■

Important safety instructions on the knee airbag system

Airbags are only supplemental restraints. Always wear safety belts correctly and ride in a proper seating position.

There is a lot that you and your passengers must know and do to help the safety belts and airbags to provide supplemental protection.

WARNING

An inflating knee airbag can cause serious injury. Wearing safety belts incorrectly and improper seating positions increase the risk of serious personal injury and death whenever a vehicle is being used.

- **The airbag system cannot protect you properly if you are seated too close to any of the airbag locations. When adjusting**

WARNING (continued)

their seat positions, it is important that both the driver and the front passenger keep their upper bodies and knees at the following minimum safe distances:

- **10 inches (25 cm) between the chest and the steering wheel/instrument panel.**
- **4 inches (10 cm) between the knees and the lower part of the instrument panel.**
- **The risk of personal injury increases if you lean forward or to the side, or if the seat is improperly positioned and you are not wearing your safety belt. The risk increases even more should the airbag deploy.**
- **Always make sure that the knee airbag can inflate without interference. Objects between yourself and the airbag can increase the risk of injury in an accident by interfering with the way the airbag deploys or by being pushed into you as the airbag deploys.**
 - **No persons (children) or animals should ride in the footwell in front of the passenger seat. If the airbag deploys, this can result in serious or fatal injuries.**
 - **No objects of any kind should be carried in the footwell area in front of the driver's or passenger's seat. Bulky objects (shopping bags, for example) can hamper or prevent proper deployment of the airbag. Small objects can be thrown through the vehicle if the airbag deploys and injure you or your passengers.**
- **Make sure there are no cracks, deep scratches or other damage in the area of the instrument panel where the knee airbags are located.**
- **If children are incorrectly seated, their risk of injury increases in the case of an accident ⇒ *page 147, “Child Safety”.* ■**

Side airbags

Description of side airbags

The airbag system can provide supplemental protection to properly restrained front seat occupants.

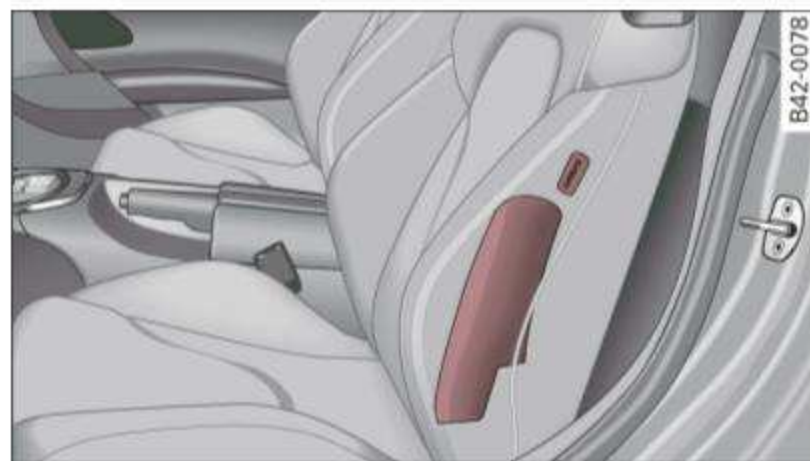

Fig. 105 Side airbag location in the driver's seat

The side airbags are located in the sides of the front seat backrests ⇒ fig. 105 facing the doors. They are identified by the word "AIRBAG".

The side airbag system basically consists of:

- the electronic control module and external side impact sensors
- the two side airbags located in the sides of the front backrests
- the airbag warning light in the instrument cluster.

The airbag system is monitored electronically to make certain that it is functioning properly at all times. Each time you turn on the ignition, the airbag system indicator light will come on for a few seconds (self diagnostics).

The side airbag system supplements the safety belts and can help to reduce the risk of injury to the driver's and front passenger's upper torso on the side of the vehicle that is struck in a side collision. The airbag deploys only in side impacts and only when the vehicle acceleration registered by the control unit is high enough. If this rate is below the reference value programmed into the control

unit, the side airbags will not be triggered, even though the car may be badly damaged as a result of the collision. It is not possible to define an airbag triggering range that will cover every possible angle of impact, since the circumstances will vary considerably between one collision and another. Important factors include, for example, the nature (hard or soft) of the impacting object, the angle of impact, vehicle speed, etc. ⇒ *page 145, "Important safety instructions on the side airbag system"*.

Aside from their normal safety function, safety belts work to help keep the driver or front passenger in position in the event of a side collision so that the side airbags can provide protection.

The airbag system is *not* a substitute for your safety belt. Rather, it is part of the overall occupant restraint system in your vehicle. Always remember that the side airbag system can only help to protect you if you are wearing your safety belt and wearing it properly. This is another reason why you should always wear your safety belts, not just because the law requires you to do so ⇒ *page 117, "Why safety belts?"*.

It is important to remember that while the supplemental side airbag system is designed to reduce the likelihood of serious injuries, other injuries, for example, swelling, bruising, and minor abrasions can also be associated with deployed side airbags. Remember too, side airbags will deploy only once and only in certain kinds of accidents - your safety belts are always there to offer protection.

Vehicle damage, repair costs or even the lack of vehicle damage are not necessarily an indication of over-sensitive or failed airbag activation. In some collisions, both front and side airbags may inflate. Remember too, that airbags will deploy only once and only in certain kinds of collisions - your safety belts are always there to offer protection in those accidents in which airbags are not supposed to deploy or when they have already deployed.

The side airbag system will not deploy:

- when the ignition is turned off
- in side collisions when the acceleration measured by the sensor is too low

- in front-end collisions
- in rear-end collisions
- in rollovers.

In some types of accidents the front airbags and side airbags may be triggered together.

WARNING

- **Safety belts and the airbag system will only provide protection when occupants are in the proper seating position** ⇒ *page 145*.
- **If the airbag indicator light comes on when the vehicle is being used, have the system inspected immediately by your authorized Audi dealer. The airbag may not work properly when the vehicle acceleration in a side collision is high enough to activate the airbag.** ■

How supplemental side airbags work

Side airbags deploy instantly and can help reduce the risk of upper torso injuries for occupants who are properly restrained.



Fig. 106 Inflated side airbags on left side of vehicle

When the system is triggered, the airbag is filled with propellant gas and breaks through a seam in the seat surface area marked

“AIRBAG”. It expands between the side trim panel and the passenger. In order to help provide this additional protection, the side airbag must inflate within a fraction of a second at very high speed and with great force. The supplemental side airbag could injure you if your seating position is not proper or upright or if items are located in the area where the supplemental side airbag expands. This applies especially to children ⇒ *page 147, “Child Safety”*. Supplemental side airbags inflate between the occupant and the door panel on the side of the vehicle that is struck in certain side collision ⇒ fig. 106.

Although they are not a soft pillow, they can “cushion” the impact and in this way they can help to reduce the risk of injury to the upper part of the body.

A fine dust may develop when the airbag deploys. This is normal and does not mean there is a fire in the vehicle. ■

Important safety instructions on the side airbag system

Airbags are only supplemental restraints. Always properly wear safety belts and ride in a proper seating position.

There is a lot that you and your passengers must know and act accordingly to help the safety belts and airbags do their job to provide supplemental protection.

WARNING

An inflating side airbag can cause serious or fatal injury. Improperly wearing safety belts and improper seating positions increase the risk of serious personal injury and death whenever a vehicle is being used.

- **In order to reduce the risk of injury when the supplemental side airbag inflates:**

⚠ WARNING (continued)

- Always sit in an upright position and never lean against the area where the supplemental side airbag is located.
- Never let a child or anyone else rest their head against the side trim panel in the area where the supplemental side airbag inflates.
- Always make sure that safety belts are worn correctly,
- Do not let anyone sitting in the front seat put their hand or any other parts of their body out of the window.
- Always make sure that the side airbag can inflate without interference.
 - Never install seat covers or replacement upholstery over the front seat backs that have not been specifically approved by Audi.
 - Never use additional seat cushions that cover the areas where the side airbags deploy.
 - Damage to the original seat covers or to the seam in the area of the side airbag module must always be repaired immediately by an authorized Audi dealer.
- Objects between you and the airbag can increase the risk of injury in an accident by interfering with the way the airbag deploys or by being pushed into you as the airbag inflates.
 - Never place or attach accessories or other objects (such as cup holders, telephone brackets, or even large, bulky objects) on the doors, over or near the area marked “AIRBAG” on the seat backrests.
 - Such objects and accessories can become dangerous projectiles and cause injury when the supplemental side airbag deploys.
 - Never carry any objects or pets in the deployment space between them and the airbags or allow children or other passengers to travel in this position.

⚠ WARNING (continued)

- Always use the built-in coat hooks only for lightweight clothing. Never leave any heavy or sharp-edged objects in the pockets that may interfere with side airbag deployment and can cause personal injury in an accident.
- Always prevent the side airbags from being damaged by heavy objects knocking against or hitting the sides of the seatbacks.
- The airbag system can only be triggered once. If the airbag has been triggered, the system must be replaced by an authorized Audi dealer.
- Damage (cracks, deep scratches etc.) to the original seat covers or to the seam in the area of the side airbag module must always be repaired immediately by an authorized Audi dealer.
- If children are seated improperly, their risk of injury increases in the case of an accident ⇒ *page 147, “Child Safety”*.
- Never attempt to modify any components of the airbag system in any way. ■

Child Safety

Important things to know

Introduction

The physical principles of what happens when your vehicle is in a crash apply also to children ⇒ *page 120*. But unlike adults and teenagers, their muscles and bones are not fully developed. In many respects children are at greater risk of serious injury in crashes than adults.

Because children's bodies are not fully developed, they require restraint systems especially designed for their size, weight, and body structure. Many countries and all states of the United States and provinces of Canada have laws requiring the use of approved child restraint systems for infants and small children.

In a frontal crash at a speed of 20-35 mph (30-56 km/h) the forces acting on a 13-pound (6 kg) infant will be more than 20 times the weight of the child. This means the weight of the child would suddenly be more than 260 pounds (120 kg). Under these conditions, only an appropriate child restraint properly used can reduce the risk of serious injury. Child restraints, like adult safety belts, must be used properly to be effective. Used improperly, they can increase the risk of serious injury in an accident.

Consult the child safety seat manufacturer's instructions to be sure the seat is right for your child's size ⇒ *page 150*, "Important safety instructions for using child safety seats". Please be sure to read and heed all of the important information and WARNINGS about child safety, Advanced Airbags, and the installation of child restraints in this chapter.

There is a lot you need to know about the Advanced Airbags in your vehicle and how they work when infants and children in child restraints are on the front passenger seat. Because of the large amount of important information, we cannot repeat it all here. We

urge you to read the detailed information in this owner's manual about airbags and the Advanced Airbag System in your vehicle and the very important information about transporting children on the front passenger seat. Please be sure to heed the WARNINGS - they are extremely important for your safety and the safety of your passengers, especially infants and small children.

WARNING

All vehicle occupants and especially children must be restrained properly whenever riding in a vehicle. An unrestrained or improperly restrained child could be injured by striking the interior or by being ejected from the vehicle during a sudden maneuver or impact. An unrestrained or improperly restrained child is also at greater risk of injury or death through contact with an inflating airbag.

WARNING

Children on the front seat of any car even with Advanced Airbags can be seriously injured or even killed when an airbag inflates. A child in a rearward-facing child safety seat installed on the front passenger seat will be seriously injured and can be killed if the front airbag inflates.

- **The inflating airbag will hit the child safety seat or infant carrier with great force and will smash the child safety seat and child against the backrest, door or roof.**
- **Never install a rearward facing child safety seat on the front passenger seat unless the PASSENGER AIR BAG OFF light comes on and stays on. If the PASSENGER AIR BAG OFF light does not come on and stay on the inflating airbag will hit the child safety seat or infant carrier with great force and will smash the child safety seat and child against the backrest, door or roof. Have the**

⚠ WARNING (continued)

airbag system inspected immediately by your authorized Audi dealer.

⚠ WARNING

If, in exceptional circumstances, you must install a forward-facing child restraint on the front passenger's seat:

- **Always make sure the forward-facing seat has been designed and certified by its manufacturer for use on a front seat with a passenger front and side airbag.**
- **Always follow the manufacturer's instructions provided with the child safety seat or carrier.**
- **Always move the passenger seat into its rearmost position in the seat's fore and aft adjustment range, as far away from the airbag as possible before installing the child restraint. The backrest must be adjusted to an upright position.**
- **Always make sure that the PASSENGER AIR BAG OFF light comes on and stays on all the time whenever the ignition is switched on. ■**

Advanced front airbag system and children

Your vehicle is equipped with an "Advanced Airbag System" in compliance with United States Federal Motor Vehicle Safety Standard (FMVSS) 208 as applicable at the time your vehicle was manufactured.

The Advanced Airbag system in your vehicle has been certified to meet the "low-risk" requirements for 3 and 6 year-old children on the passenger side and small adults on the driver side. The low risk deployment criteria are intended to reduce the risk of injury through interaction with the airbag that can occur, for example, by being too close to the steering wheel and instrument panel when the airbag inflates. In addition, the system has been certified to comply with

the "suppression" requirements of the Safety Standard, to turn off the front airbag for infants up to 12 months who are restrained on the front passenger seat in child restraints that are listed in the Standard.

Even though your vehicle is equipped with an Advanced Airbag system, a child should always ride in the seat properly restrained for its age and size. The airbag on the passenger side makes the front seat a potentially dangerous place for a child to ride. The front seat is not the safest place for a child in a forward-facing child safety seat. It can be a very dangerous place for an infant or a larger child in a rearward-facing seat. ■

Advanced Airbags and the weight-sensing mat in the front seat

The Advanced Airbag System in your vehicle detects the presence of an infant or child in a child restraint on the front passenger seat using the weight-sensing mat in the seat cushion and the sensor below the safety belt latch on the front passenger seat that measures the tension on the safety belt.

The weight-sensing mat measures total weight of the child and the child safety seat and a child blanket on the front passenger seat. The weight on the front passenger seat is related to the design of the child restraint and its "footprint", the size and shape of the bottom of the child restraint as it sits on the seat. The weight of a child restraint and its "footprint" vary for different kinds of child restraints and for the different models of the same kind of child restraint offered by child restraint manufacturers.

The weight ranges for the individual types, makes and models of child restraints that the NHTSA has specified in the Safety Standard together with the weight ranges of typical infants and typical 1 year-old child have been stored in the control unit of the Advanced Airbag System. When a child restraint is being used on the front passenger seat with a typical 1 year-old child, the Advanced Airbag ►

System compares the weight measured by the weight sensing mat with the information stored in the electronic control unit.

The electronic control unit also registers the tension on the front passenger safety belt. The tension on the safety belt for the front passenger seat will be different for an adult who is properly using the safety belt as compared to the tension on the belt when it is used to attach a child restraint to the seat. The sensor below the latch for the safety belt for the front seat passenger measures the tension on the belt. The input from this sensor is then used with the weight to “decide”, whether there is a child restraint with a typical 1 year-old child on the front passenger seat and whether or not the airbag must be turned off. ■

Child restraints and Advanced Airbags

Regardless of the child restraint that you use, make sure that it has been certified to meet United States Federal Motor Vehicle Safety Standards and has been certified by its manufacturer for use with an airbag. If in exceptional circumstances you must use it on the front passenger seat, carefully read all of the information on child safety and Advanced Airbags and heed all of the applicable WARNINGS. Make certain that the child restraint is correctly recognized by the weight-sensing mat inside the front passenger seat, that the front passenger airbag is turned off and that the airbag status is always correctly signaled by the **PASSENGER AIR BAG OFF** light.

Many types and models of child restraints have been available over the years, new models are introduced regularly incorporating new and improved designs and older models are taken out of production. Child restraints are not standardized. Child restraints of the same type typically have different weights and sizes and different 'footprints,' the size and shape of the bottom of the child restraint that sits on the seat, when they are installed on a vehicle seat. These differences make it virtually impossible to certify compliance with the requirements for advanced airbags with each and every child restraint that has ever been sold in the past or will be sold over the course of the useful life of your vehicle.

For this reason, the United States National Highway Traffic Safety Administration has published a list of specific type, makes and models of child restraints that must be used to certify compliance of the Advanced Airbag System in your vehicle with the suppression requirements of Federal Motor Vehicle Safety Standard 208. These child restraints are:

A. Car beds, manufactured on or after September 1, 2004:

- Cosco Dream Ride 02-719

B. Rear facing child restraint systems, manufactured on or after September 1, 2004:

(When the restraint system comes equipped with a removable base, compliance has to be certified with or without the base).

- Britax Handle with Care 191
- Century Assura 4553
- Century Smart Fit 4543
- Cosco Arriva 02727
- Evenflo Discovery Adjust Right 212
- Evenflo First Choice 204
- Graco Infant 8457

C. Forward-facing convertible child restraint systems, manufactured on or after September 1, 2004:

- Britax Roundabout 161
- Britax Expressway
- Century Encore 4612
- Century STE 1000 4416
- Cosco Olympian 02803
- Cosco Touriva 02519
- Evenflo Horizon V 425
- Evenflo Medallion 254
- Safety First Comfort Ride 22-400

 **WARNING**

To reduce the risk of serious injury, make sure that the **PASSENGER AIR BAG OFF** light comes on and stays on whenever a child restraint is installed on the front passenger seat and the ignition is switched on.

- **Never install a rearward facing child safety seat on the front passenger seat unless the PASSENGER AIR BAG OFF light comes on and stays on. If the PASSENGER AIR BAG OFF light does not come on and stay on the inflating airbag will hit the child safety seat or infant carrier with great force and will smash the child safety seat and child against the backrest, door or roof. Have the airbag system inspected immediately by your authorized Audi dealer.**

 **Tips**

The child seats listed in categories A to C have been tested by Audi only for the Advanced Airbag function. ■

Important safety instructions for using child safety seats

Correct use of child safety seats substantially reduces the risk of injury in an accident!

As the driver, you are responsible for the safety of everybody in the vehicle, especially children:

- Always use the right child safety seat for each child and always use it properly ⇒ *page 152*.
- Always carefully follow the child safety seat manufacturer's instructions on how to route the safety belt properly through the child safety seat.

- When using the vehicle safety belt to install a child safety seat, you must first activate the convertible locking retractor on the safety belt to prevent the child safety seat from moving ⇒ *page 156*.
- Push the child safety seat down with your full weight to get the safety belt really tight so that the seat cannot move forward or sideways more than one inch (2.5 cm).

Always remember: Even though your vehicle is equipped with an Advanced Airbag system, a child should always ride in the seat properly restrained for its age and size.

 **WARNING**

Not using a child safety seat, using the wrong child safety seat or improperly installing a child restraint increases the risk of serious personal injury and death.

- **All vehicle occupants and especially children must always be restrained properly whenever riding in a vehicle.**
 - **An unrestrained or improperly restrained child can be injured or killed by being thrown against the inside of the vehicle or by being ejected from it during a sudden maneuver or impact.**
 - **An unrestrained or improperly restrained child is at much greater risk of injury or death by being struck by an inflating airbag.**
- **Commercially available child safety seats are required to comply with U.S. Federal Motor Vehicle Safety Standard (FMVSS) 213 (in Canada CMVSS 213).**
 - **When buying a child restraint, select one that fits your child and the vehicle.**
 - **Only use child restraint systems that fully contact the flat portion of the seat cushion. The child restraint must not tip or lean to either side. Audi does not recommend using child safety seats that rest on legs or tube-like frames. They do not provide adequate contact with the seat.**

 WARNING (continued)

- Always heed all legal requirements pertaining to the installation and use of child safety seats and carefully follow the instructions provided by the manufacturer of the seat you are using.
- Never let more than one child occupy a child safety seat.
- Never let babies or older children ride in a vehicle while sitting on the lap of another passenger.
 - Holding a child in your arms is never a substitute for a child restraint system.
 - The strongest person could not hold the child with the forces that exist in an accident. The child will strike the interior of the vehicle and can also be struck by the passenger.
 - The child and the passenger can also injure each another in an accident.
- Never install a rearward facing child safety seat on the front passenger seat unless the PASSENGER AIR BAG OFF light comes on and stays on. If the PASSENGER AIR BAG OFF light does not come on and stay on the inflating airbag will hit the child safety seat or infant carrier with great force and will smash the child safety seat and child against the backrest, door or roof. Have the airbag system inspected immediately by your authorized Audi dealer.
- Forward-facing child safety seats installed on the front passenger's seat can interfere with the airbag when it inflates and cause serious injury to the child.
- If exceptional circumstances require the use of a forward-facing child restraint on the front passenger's seat, the child's safety and well-being require that the following special precautions be taken:
 - Make sure the forward-facing seat has been designed and certified by its manufacturer for use on a front seat with a passenger front and side airbag.

 WARNING (continued)

- Always carefully follow the manufacturer's instructions provided with the child safety seat or carrier.
- Always move the front passenger seat into the rearmost position of the passenger seat's fore and aft adjustment range, and as far away from the airbag as possible before installing the child restraint.
 - Always make sure that nothing prevents the front passenger's seat from being moved to the rearmost position in its fore and aft adjustment range.
 - Always make sure that the backrest is in the upright position.
- Always buckle the child safety seat firmly in place even if a child is not sitting in it. A loose child safety seat can fly around during a sudden stop or in a collision.
- Always read and heed all WARNINGS whenever using a child restrained in a vehicle is being used ⇒ *page 116, "Safety belts"*, ⇒ *page 125, "Airbag system"* and ⇒ *page 147, "Child Safety"*.

 WARNING

To reduce the risk of serious injury, make sure that the PASSENGER AIR BAG OFF light comes on and stays on whenever a child restraint is installed on the front passenger seat and the ignition is switched on.

- Never install a rearward facing child safety seat on the front passenger seat unless the PASSENGER AIR BAG OFF light comes on and stays on. If the PASSENGER AIR BAG OFF light does not come on and stay on the inflating airbag will hit the child safety seat or infant carrier with great force and will smash the child safety seat and child against the backrest, door or roof. Have the airbag system inspected immediately by your authorized Audi dealer. ■

Child safety seats

Infant seats

Babies and infants up to about one year old and 22 lbs or 10 kg need special rearward-facing child restraints that support the back, neck and head in a crash.



Fig. 107 Rearward-facing infant seat, properly installed on the passenger seat

- When using the vehicle safety belt to install a child safety seat, you must first activate the convertible locking retractor on the safety belt to prevent the child safety seat from moving ⇒ *page 156*.
- Push the child safety seat down with your full weight to get the safety belt really tight so that the seat cannot move forward or sideways more than one inch (2.5 cm).

Infants up to about one year (22 lbs. or 10 kg) are best protected in special infant carriers and child safety seats designed for their age group. Many experts believe that infants and small children should ride only in special restraints in which the child faces the back of the vehicle. These infant seats support the baby's back, neck and head in a crash.

WARNING

Not using a child safety seat, using the wrong child safety seat or improperly installing a child restraint increases the risk of serious personal injury and death in a crash.

- Never install a rear-facing child restraint in the forward-facing direction. Such restraints are designed for the special needs of infants and very small children and cannot protect them properly if the seat is forward-facing.
- Never install a rearward facing child safety seat on the front passenger seat unless the PASSENGER AIR BAG OFF light comes on and stays on. If the PASSENGER AIR BAG OFF light does not come on and stay on the inflating airbag will hit the child safety seat or infant carrier with great force and will smash the child safety seat and child against the backrest, door or roof. Have the airbag system inspected immediately by your authorized Audi dealer.
- Always read and heed all WARNINGS whenever using a child restrained in a vehicle is being used ⇒ *page 116, "Safety belts"*, ⇒ *page 125, "Airbag system"* and ⇒ *page 147, "Important things to know"*. ■

Convertible child safety seats

Properly used convertible child safety seats can help protect toddlers and children over age one who weigh between 20 and 40 lbs. (10 and 20 kg) in a crash.



Fig. 108 Passenger seat: smaller child in a properly installed forward-facing convertible child safety seat

- When using the vehicle safety belt to install a child safety seat, you must first activate the convertible locking retractor on the safety belt to prevent the child safety seat from moving ⇒ *page 156*.
- Push the child safety seat down with your full weight to get the safety belt really tight so that the seat cannot move forward or sideways more than one inch (2.5 cm) ⇒ *page 156*.

A toddler or child is usually too large for an infant restraint if it is more than one year old and weighs more than 22 lbs. (10 kg).

Toddlers and children who are older than one year up to about 4 years old and weigh more than 22 lbs (10 kg) up to 40 lbs. (18 kg) should be properly restrained in a child safety seat certified for their size and weight ⇒ *fig. 108*.

The airbag on the passenger side makes the front seat a potentially dangerous place for a child to ride. The front seat is not the safest place for a child in a forward-facing child safety seat. It is a very

dangerous place for an infant or a larger child in a rearward-facing seat.

WARNING

Not using a child safety seat, using the wrong child safety seat or improperly installing a child restraint increases the risk of serious personal injury and death in a collision or other emergency situation.

- Children on the front seat of any car, even with Advanced Airbags, can be seriously injured or even killed when an airbag inflates. A child in a rearward-facing child safety seat installed on the front passenger seat will be seriously injured and can be killed if the front airbag inflates – even with an Advanced Airbag System.
- The inflating airbag will hit the child safety seat or infant carrier with great force and will smash the child safety seat and child against the backrest, door or roof.
- Never install a rearward facing child safety seat on the front passenger seat unless the PASSENGER AIR BAG OFF light comes on and stays on. If the PASSENGER AIR BAG OFF light does not come on and stay on have the airbag system inspected immediately by your authorized Audi dealer.
- Always read and heed all WARNINGS whenever using a child restrained in a vehicle is being used ⇒ *page 116*, “Safety belts”, ⇒ *page 125*, “Airbag system” and ⇒ *page 147*, “Important things to know”.

WARNING

If exceptional circumstances require the use of a forward-facing child restraint on the front passenger's seat, the child's safety and well-being require that the following special precautions be taken:

- Make sure the forward-facing seat has been designed and certified by its manufacturer for use on a front seat with a passenger front and side airbag.

⚠ WARNING (continued)

- Always follow the manufacturer's instructions provided with the child safety seat or carrier.
- Always move the front passenger seat into the rearmost position of the passenger seat's fore and aft adjustment range, and as far away from the airbag as possible before installing the child restraint.
- Always make sure that nothing prevents the front passenger's seat from being moved to the rearmost position in its fore and aft adjustment range.
- Always make sure the backrest is in an upright position.
- Make sure that the PASSENGER AIR BAG OFF light comes on and stays on all the time whenever the ignition is switched on.
- If the light does not stay on, perform the checks ⇒ *page 136*, "Monitoring the Advanced Airbag System".
- If the PASSENGER AIR BAG OFF light does not come on and stay on have the airbag system inspected immediately by your authorized Audi dealer. ■

Booster seats

Properly used booster seats can help protect children weighing between about 40 lbs. and 80 lbs. (18 kg and 36 kg) who are less than 4 ft. 9 in. tall.



Fig. 109 Passenger seat: child properly restrained in a booster seat

The vehicle's safety belts alone will not fit most children until they are at least 4 ft. 9 in. tall and weigh about 80 lbs. (36 kg). Booster seats raise these children up so that the safety belt will pass properly over the stronger parts of their bodies and the safety belt can help protect them in a crash.

- Do not use the convertible locking retractor when using the vehicle's safety belt to restrain a child on a booster seat.
- Always position the shoulder portion of the safety belt midway over the child's shoulder.
- Always make sure that the shoulder portion of the safety belt never rests against or across the child's neck.
- Always make sure that the child can properly wear the lap portion of the belt low across the thighs or pelvis and *never* over the stomach or abdomen. ▶

Children up to about 40 lbs (18 kg) are best protected in child safety seats designed for their age and weight. Experts say that the skeletal structure, particularly the pelvis, of these children is not fully developed, and they should not use the vehicle safety belts ⇒ fig. 109.

Children who weigh more than 40 lbs. (18 kg) may generally use the available three point combination lap and shoulder belts when they sit on an appropriate booster seat. Be sure the booster seat meets all applicable safety standards.

Booster seats raise the seating position of the child and reposition both the lap and shoulder parts of the safety belt so that they pass across the child's body in the right places. The routing of the belt over the child's body is very important for the child's protection. This applies whenever a child uses the vehicle's safety belts, even when the child is big enough to use them without a booster seat.

In a crash, airbags must inflate within a blink of an eye and with considerable force. In order to do its job, the airbag needs room to inflate so that it will be there to protect the occupant as the occupant moves forward into the airbag.

A vehicle occupant including a child who is out of position and too close to the airbag gets in the way of an inflating airbag. When an occupant is too close, he or she will be struck violently and will receive serious or possibly even fatal injury.

In order for the airbag to offer protection, it is important that all vehicle occupants, especially any children, who must be in the front seat in exceptional circumstances, be properly restrained and as far away from the airbag as possible. By keeping room between the child's or other occupant's body and the front of the passenger compartment, the airbag can inflate fully and completely and provide supplemental protection in certain frontal crashes.

WARNING

Not using a booster seat, using the booster seat improperly, incorrectly installing a booster seat or using the vehicle safety belt

WARNING (continued)

improperly increases the risk of serious personal injury and death in a collision or other emergency situation. To help reduce the risk of serious personal injury and/or death:

- **Always make sure to position the shoulder portion of the three-point belt over the middle of child's shoulder.**
- **Never let the shoulder portion of the belt rest against or across the neck, face, chin, or throat of the child.**
- **Always make sure the lap belt portion of the three-point belt is worn snug and passes as low as possible across the child's pelvis. Never let the belt pass over the soft abdomen.**
- **Failure to properly route safety belts over a child's body will cause severe injuries in an accident or other emergency situation ⇒ page 116.**
- **Children on the front seat of any car, even with Advanced Airbags, can be seriously injured or even killed when an airbag inflates. A child in a rearward-facing child safety seat installed on the front passenger seat will be seriously injured and can be killed if the front airbag inflates.**
- **Never let a child stand or kneel on any seat, for example the front seat.**
- **Never let a child ride in the cargo area of your vehicle.**
- **Always remember that a child leaning forward, sitting sideways or out of position in any way during an accident can be struck by a deploying airbag. This will result in serious personal injury or death.**
- **If you must install a rearward facing child safety seat on the front passenger seat because of exceptional circumstances the PASSENGER AIR BAG OFF light must come on and stay on, whenever the ignition is switched on.**
- **If the PASSENGER AIR BAG OFF light does not come on and stay on, perform the checks described ⇒ page 136, "Monitoring the Advanced Airbag System".**

⚠ WARNING (continued)

- Never install a rearward facing child safety seat on the front passenger seat unless the PASSENGER AIR BAG OFF light comes on and stays on. If the PASSENGER AIR BAG OFF light does not come on and stay on the inflating airbag will hit the child safety seat or infant carrier with great force and will smash the child safety seat and child against the backrest, door or roof. Have the airbag system inspected immediately by your authorized Audi dealer.
- Always read and heed all WARNINGS whenever using a child restrained in a vehicle is being used ⇒ *page 116, "Safety belts"*, ⇒ *page 125, "Airbag system"* and ⇒ *page 147, "Important things to know"*. ■

Safety belts and older children

Properly worn three point lap and shoulder belt can help protect children weighing more than 80 lbs. (36 kg) and who are at least 4 ft. 9 in. tall.



Fig. 110 Child taller than 4 ft. 9 in. properly restrained on the front seat

Children who weigh more than about 80 lbs (36 kg) and are at least 4 ft. 9 in. tall can generally use the vehicle's three point lap and shoulder belts.

⚠ WARNING

Using wrong child restraints or improperly installed child restraints can cause serious personal injury or death in a crash.

- Failure to properly route safety belts over a child's body will cause severe injuries in a crash. The lap belt portion of the three point belt must always pass as low as possible across the pelvis, never over the stomach or abdomen.
- An improperly worn safety belt will not provide the best protection in a crash and may cause serious personal injury. Always make sure that children and other vehicle occupants properly wear available restraint systems. Carefully follow the instructions provided by the manufacturers of child restraints. ■

Installing a child safety seat**Securing a child safety seat using a safety belt**

Safety belts for the front passenger can be locked with the convertible locking retractor to properly secure child safety seats.

The safety belts emergency locking retractors for the front passenger's seat safety belt have a convertible locking retractor for child restraints. The safety belt must be locked so that belt webbing cannot unreel. The retractor can be activated to lock the safety belt and prevent the safety belt webbing from loosening up during normal driving. A child safety seat can only be properly installed when the safety belt is locked so that the child and child safety seat will stay in place.

Always remember: Even though your vehicle is equipped with an Advanced Airbag system, a child should always ride in the seat properly restrained for its age and size. ▶

 **WARNING**

Improperly installed child safety seats increase the risk of serious personal injury and death in a collision.

- Always make sure that the safety belt retractor is locked when installing a child safety seat. An unlocked safety belt retractor cannot hold the child safety seat in place during normal driving or in a crash.
- Always buckle the child safety seat firmly in place even if a child is not sitting in it. A loose child safety seat can fly around during a sudden stop or in a collision
- The inflating airbag will hit the child safety seat or infant carrier with great force and will smash the child safety seat and child against the backrest, door or roof.
- Forward-facing child safety seats or infant carriers installed on the front passenger's seat may interfere with the deployment of the airbag and cause serious injury to the child.
- Always read and heed all WARNINGS whenever using a child restrained in a vehicle is being used ⇒ *page 147*. Special precautions apply when installing a child safety seat on the front passenger seat ⇒ *page 127*, "Child restraints on the front seat – some important things to know".

 **WARNING**

Always take special precautions if you must install a forward or rearward-facing child restraint on the front passenger's seat in exceptional situations:

- Whenever a forward or rearward-facing child restraint is installed on the front passenger seat, the PASSENGER AIR BAG OFF light must come on and stay on whenever the ignition is switched on.
- If the PASSENGER AIR BAG OFF light does not come on and stay on, perform the checks described ⇒ *page 136*, "Monitoring the Advanced Airbag System".

 **WARNING (continued)**

- Never install a rearward facing child safety seat on the front passenger seat unless the PASSENGER AIR BAG OFF light comes on and stays on. If the PASSENGER AIR BAG OFF light does not come on and stay on the inflating airbag will hit the child safety seat or infant carrier with great force and will smash the child safety seat and child against the backrest, door or roof. Have the airbag system inspected immediately by your authorized Audi dealer.
- Improper installation of child restraints can reduce their effectiveness or even prevent them from providing any protection.
- An improperly installed child restraint can interfere with the airbag as it deploys and seriously injure or even kill the child.
- Always carefully follow the manufacturer's instructions provided with the child safety seat or carrier.
- Never place additional items on the seat that can increase the total weight registered by the weight-sensing mat and can cause injury in a crash.

 **WARNING**

Forward-facing child restraints:

- Always make sure the forward-facing seat has been designed and certified by its manufacturer for use on a front seat with a passenger front and side airbag.
- Never put the forward-facing child restraint up, against or very near the instrument panel.
- Always move the passenger seat into its rearmost position in the seat's fore and aft adjustment range, as far away from the airbag as possible before installing the forward-facing child restraint. The backrest must be adjusted to an upright position.
- Make sure that the PASSENGER AIR BAG OFF light comes on and stays on all the time whenever the ignition is switched on. ▶

 **WARNING**
Rearward-facing child restraints:

- A child in a rearward-facing child safety seat installed on the front passenger seat will be seriously injured and can be killed if the front airbag inflates - even with an Advanced Airbag System.
- The inflating airbag will hit the child safety seat or infant carrier with great force and will smash the child safety seat and child against the backrest, door or roof.
- Always be especially careful if you must install a rearward facing child safety seat on the front passenger seat in exceptional circumstances.
- Make sure that the PASSENGER AIR BAG OFF light comes on and stays on all the time whenever the ignition is switched on.
- Never install a rearward facing child safety seat on the front passenger seat unless the PASSENGER AIR BAG OFF light comes on and stays on. If the PASSENGER AIR BAG OFF light does not come on and stay on the inflating airbag will hit the child safety seat or infant carrier with great force and will smash the child safety seat and child against the backrest, door or roof. Have the airbag system inspected immediately by your authorized Audi dealer. ■

Activating the convertible locking retractor

Use the convertible locking retractor to secure a child restraint.

Always heed the child safety seat manufacturer's instructions when installing a child restraint in your vehicle. To activate the convertible locking retractor:

- Place the child restraint on a seat.
- Slowly pull the belt **all the way out**.

- Route it around or through the child restraint belt path ⇒ .
- Push the child safety seat down with your full weight to get the safety belt really tight.
- Insert the belt tongue into the buckle for that seating position.
- Guide the safety belt back into the retractor until the belt lies flat and snug on the child safety seat.
- You should hear a “clicking” noise as the belt winds back into the inertia reel. Test the convertible locking retractor by pulling on the belt. You should no longer be able to pull the belt out of the retractor. The convertible locking retractor is now activated.
- Make sure that the red release button is facing away from the child restraint so that it can be unbuckled quickly.
- Pull on the belt to make sure the safety belt is properly tight and fastened so that the seat cannot move forward or sideways more than one inch (2.5 cm).

 **WARNING**

Using the wrong child restraint or an improperly installed child restraint can cause serious personal injury or death in a crash.

- Always make sure that the safety belt retractor is locked when installing a child safety seat. An unlocked safety belt retractor cannot hold the child safety seat in place during normal driving or in a crash.
- Always buckle the child safety seat firmly in place even if a child is not sitting in it. A loose child safety seat can fly around during a sudden stop or in a crash. ▶

⚠ WARNING (continued)

- Always make sure the seat backrest to which the child restraint is installed is in an upright position. Otherwise, the seat back with the child safety seat attached to it could fly forward in the event of an accident or other emergency situation.
- Always read and heed all WARNINGS whenever using a child restrained in a vehicle is being used ⇒ *page 147*. Special precautions apply when installing a child safety seat on the front passenger seat ⇒ *page 127*, "Child restraints on the front seat – some important things to know". ■

Deactivating the convertible locking retractor

The convertible locking retractor for child restraints will be deactivated automatically when the belt is wound all the way back into the retractor.

- Press the red button on the safety belt buckle. The belt tongue will pop out of the buckle.
- Guide the belt all the way back into its stowed position.

Always let the safety belt retract completely into its stowed position. The safety belt can now be used as an ordinary safety belt without the convertible locking retractor for child restraints.

If the convertible locking retractor should be activated inadvertently, the safety belt must be unfastened and guided completely back into its stowed position to deactivate this feature. If the convertible locking retractor is not deactivated, the safety belt will gradually become tighter and uncomfortable to wear.

⚠ WARNING

Improperly installed child safety seats increase the risk of serious personal injury and death in a collision.

⚠ WARNING (continued)

- Never unfasten the safety belt to deactivate the convertible locking retractor for child restraints while the vehicle is moving. You would not be restrained and could be seriously injured in an accident.
- Always read and heed all WARNINGS whenever using a child restrained in a vehicle is being used ⇒ *page 147*. Special precautions apply when installing a child safety seat on the front passenger seat ⇒ *page 127*, "Child restraints on the front seat – some important things to know". ■

Tether for children**Tether strap**

A tether is a straight or V-shaped strap that attaches the top part of a child restraint to special anchorage points in the vehicle.

The purpose of the tether is to reduce the forward movement of the child restraint in a crash, in order to help reduce the risk of head injury that could be caused by striking the vehicle interior.

The tether strap anchor bracket is located behind the front passenger's seat at the rear panel to the engine compartment.

Forward facing child restraints manufactured after September 1, 1999, are required by U.S. federal regulations to comply with child head movement performance requirements. These new performance requirements make a tether necessary on most new child safety seats.

⚠ WARNING

Improper installation of child restraints will increase the risk of injury in a crash.

⚠ WARNING (continued)

- Never attach a child safety seat tether strap to a tie-down hook in the luggage compartment.
- Never secure or attach any luggage or other items to the tether.
- If a tether or other strap is used to attach a child restraint to the front passenger seat, make sure that it is not so tight, that it causes the weight-sensing mat to measure more weight than is actually on the seat.
- The heavier weight registered can make the system work as though an adult were on the seat and deploy the Advanced Airbag when it must be suppressed causing serious or even fatal injury to the child. ■

Using tethers on rear-facing child restraint systems

Currently, few rear-facing child restraint systems come with a tether. Please read and heed the child restraint system manufacturer's instructions carefully to determine how to properly install the tether.

⚠ WARNING

A child in a rearward-facing child safety seat installed on the front passenger seat will be seriously injured and can be killed if the front airbag inflates - even with an Advanced Airbag System.

- The inflating airbag will hit the child safety seat or infant carrier with great force and will smash the child safety seat and child against the backrest, or door.
- A tight tether or other strap on a rearward-facing child restraint attached to the front passenger seat can put too much pressure on the weight-mat in the seat and register a heavier weight in the Advanced Airbag System. The heavier weight registered can make the system work as though an adult were on the seat and deploy

⚠ WARNING (continued)

the Advanced Airbag when it must be suppressed causing serious or even fatal injury to the child.

- Never install a rearward facing child safety seat on the front passenger seat unless the PASSENGER AIR BAG OFF light comes on and stays on. If the PASSENGER AIR BAG OFF light does not come on and stay on the inflating airbag will hit the child safety seat or infant carrier with great force and will smash the child safety seat and child against the backrest, door or roof. Have the airbag system inspected immediately by your authorized Audi dealer. ■

Securing the upper tether strap to the anchor bracket

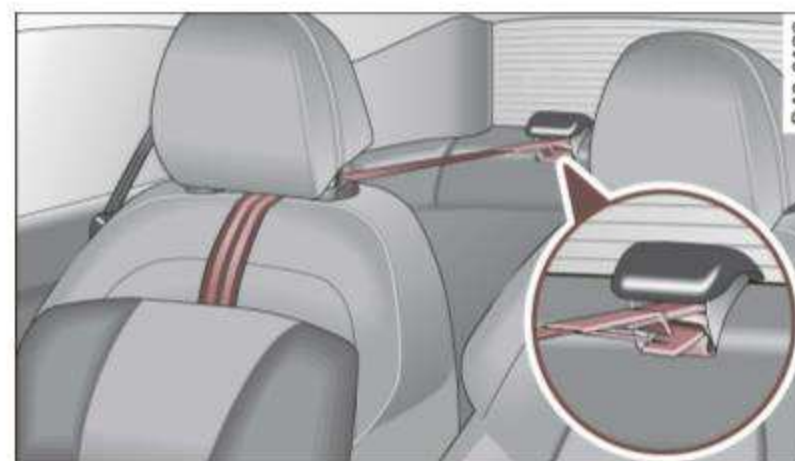

Fig. 111 Tether strap: Proper mounting and mounting

The tether strap anchor bracket is located behind the front passenger's seat at the rear panel to the engine compartment. ▶

Securing the child restraint tether strap to the tether anchor

- Release or deploy the tether strap on the child restraint according to the child restraint manufacturer's usage instructions.
- Guide the upper tether strap under the head restraint.
- Tilt the recess flap up to expose the anchor bracket ⇒ fig. 111.
- Slide the tether strap hook over the anchor bracket.
- Pull on the tether strap hook so that the spring catch of the hook engages.
- Tighten the tether strap firmly following the child restraint manufacturer's instructions.

Releasing the tether strap

- Loosen the tension following the child restraint manufacturer's instructions.
- Depress the spring catch on the hook and release it from the tether anchor.

WARNING

Always read and heed all WARNINGS.

Note

If you leave the child restraint with the tether strap firmly installed for several days, this could leave a mark on the upholstery on the seat cushion and backrest in the area where the tether strap was installed. The upholstery would also be permanently stretched around the tether strap. This applies especially to leather seats. ■

Additional Information

Where can I get additional information about child restraint application and usage?

There are a number of sources of additional information about child restraint selection, installation and usage:

NHTSA advises that the best child safety seat is the one that fits your child and fits in your vehicle, and that you will use correctly and consistently.

Try before you buy!

National Highway Traffic Safety Administration

Tel.: (888) DASH-2-DOT

www.nhtsa.dot.gov

National SAFE KIDS Campaign

Tel.: (202) 662-0600

www.safekids.org

Safety BeltSafe U.S.A

Tel.: (800) 745-SAFE (English)

Tel.: (800) 747-SANO (Spanish)

www.carseat.org

Transport Canada

Tel.: (888) 675-6863

www.tc.gc.ca

Audi Client Relations

Tel.: (800) 822-2834

Sit Safe® Audi Child Passenger Safety Program

Tel.: Tel.: 1-800-337-7116

www.programprofessionals.org ■



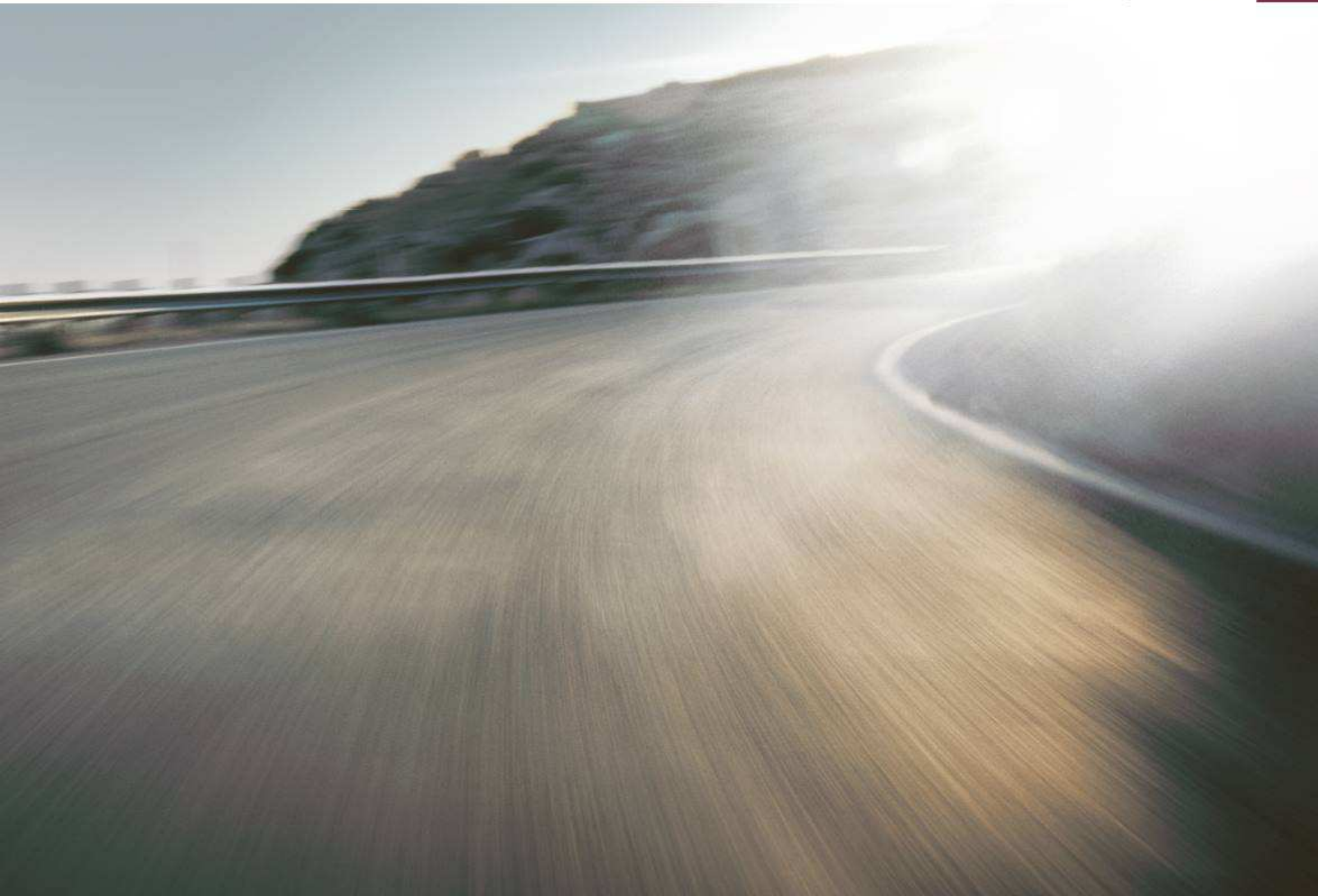

Intelligent technology

Notice about data recorded by vehicle control modules

Your vehicle is not equipped with an Event Data Recorder (EDR), installed by some manufacturers for the express purpose of capturing data for retrieval after an accident or crash event. EDR's are sometimes called "crash recorders".

Some state laws restrict the retrieval or downloading of data stored by EDR's that were installed in a vehicle for the express purpose of retrieving data after an accident or crash event without the owner's consent.

Although your vehicle is not equipped with an EDR, it is equipped with a number of electronic control modules for various vehicle systems such as, for example, engine function, emission control, as well as for the airbags and safety belts.

These electronic control modules also record vehicle-related data during normal vehicle operation for diagnostic and repair purposes. The recording capacity of the electronic control modules is limited to data (no sound is recorded) and only a small amount of data is actually recorded over a very limited period of time and stored when a system fault or other condition is sensed by a control unit. Some of the data then stored may relate to vehicle speed, direction, braking as well as restraint system use and performance in the event of a crash or other condition. Stored data can only be read and downloaded with special equipment. ■

Electronic Stabilization Program (ESP)

The Electronic Stabilization Program increases driving stability.



Fig. 112 Center console with ESP switch

Intent and purpose

The Anti-Lock Brake System (ABS), Electronic Differential Lock (EDS) and Anti-Slip Regulation System (ASR) are integrated in the Electronic Stabilization Program (ESP). It increases control over the vehicle in handling conditions close to the limit of "grip", such as when accelerating and cornering. It reduces the risk of skidding under all road conditions and at all speeds and improves vehicle stability. When road conditions are poor, ESP makes it easier to start from a complete stop as well as accelerate and drive up hills. ESP switches on automatically when you start the engine. It should normally be activated at all times because this ensures optimum vehicle stability.

Critical driving situations

With an *oversteering* vehicle (the vehicle turns too sharply and the rear wheels slide toward the outside of a curve), ESP primarily brakes the outside front wheel, with an *understeering* vehicle (the vehicle does not turn sharply enough and pushes out of a curve) it ►

brakes the inside rear wheel or other additional wheels. This brake intervention is accompanied by noises.

If the speed of a wheel slows down too much relative to vehicle speed while braking and it starts to lock, brake pressure to this wheel is reduced. This adjustment process can be felt as a pulsing motion of the brake pedal, accompanied by some noises. In order for ABS to be able to operate optimally in this range, you must keep the brake pedal depressed - never "pump the brakes". You should not expect that braking distances will be *shortened* under all circumstances with ABS. Braking distance may even be slightly *longer*, for example on gravel or with fresh snow on a slippery surface.

If a significant *speed differential* between the drive wheels on one axle is determined (for example, on a surface that is slippery *on one side*), the EDS brakes the spinning wheel and transfers power to the other drive wheels. This is done up to a speed of about 60 mph (100 km/h). Noises from the brake system signal that wheel spin is being controlled.

If one wheel spins when starting from a complete stop because of a different grip (for example, one wheel on ice), keep your foot *hard* on the accelerator until the vehicle starts to move.

If the wheels spin, ASR will automatically reduce engine torque and match power to road surface conditions.

Switching on Sport mode

In specific driving situations (e.g. Launch Control), you switch ASR and ESP to Sport mode by pressing the **ESP** button once. The ESP indicator light in the Driver Information System display comes on and **ASR off** appears. "Slip" is matched to the speed. You should do this only if your driving skill and traffic conditions permit.

Switching ASR/ESP off

In certain situations (e.g. in deep snow, on a loose surface, or when rocking the vehicle free), switch ASR and ESP off by pressing the **ESP** button for more than 3 seconds. The ESP indicator light in the Driver Information System display comes on and **ESP switched off**

appears. You should do this only if your driving skill and traffic conditions permit.

Switching ASR/ESP on

Activate ASR/ESP by pressing the **ESP** button again.

Brake overheating

So that the disc brake on a braked wheel does not overheat, the EDS switches off automatically if there is unusually severe loading at this wheel. The vehicle is still drivable and has the same properties as a vehicle without EDS.

As soon as the brake has cooled down, EDS switches on again automatically.



WARNING

- **Even ESP, ABS, EDS and ASR cannot overcome the laws of physics. You should keep this in mind in particular on an icy or wet road. If the systems intervene, you should adjust your speed immediately to road and traffic conditions. Do not be tempted by the increased safety provided to take risks – you risk having an accident.**
- **Please keep in mind that the risk of an accident is increased by driving too fast, particularly in corners and on icy or wet roads, and by driving too close to the vehicle ahead. Even ESP, ABS, EDS and ASR cannot eliminate the increased risk of having an accident.**
- **Apply the throttle carefully when accelerating on a consistently slippery surface, e.g. on ice and snow. The drive wheels can spin in spite of the EDS and thereby affect vehicle stability - you risk having an accident.**
- **Please note that when ASR or ESP/ASR is deactivated, the drive wheels can spin on icy and slippery roads and the vehicle can break away - there is a risk of skidding!**

Tips

- In the event of a defect in the rear spoiler system or in Audi magnetic ride, it can happen that ASR and ASR/ESP cannot be deactivated, or they are activated automatically in the deactivated state.
- If a malfunction occurs in the EDS, this is signaled by an indicator light, see ⇒ page 20.
- Some tracks (e.g. steeply banked turns) may affect ESP response. ■

Rear spoiler

The rear spoiler improves vehicle handling and enhances driver control.



Fig. 113 Switch for rear spoiler

The rear spoiler deploys and retracts. Spoiler operation can be set for automatic or manual operation.

Automatic mode (normal operation)

- Automatic deployment: At a speed of about 65 mph (100 km/h), the rear spoiler deploys automatically.
- Automatic retraction: When speed drops below about 20 mph (35 km/h), the rear spoiler retracts automatically.

Manual mode

- Manual deployment: Tapping briefly on the switch ⇒ fig. 113 deploys the rear spoiler.
- Manual retraction: At speeds up to about 10 mph (20 km/h), retract the rear spoiler by pressing and holding the switch. At speeds between 10 mph (20 km/h) and 65 mph (100 km/h), retract the rear spoiler by tapping on the switch.

After 15 cycles (deploy and retract), manual operation is suspended for up to 2.5 minutes. Above 65 mph (100 km/h), operation switches to automatic mode.

WARNING

Driving at higher speeds without the rear spoiler deployed can impair handling characteristics, making the vehicle harder to control.

- If the rear spoiler warning/indicator light in the instrument cluster comes on, the rear spoiler may not have deployed. Never drive at speeds higher than 85 mph (140 km/h) if the spoiler is not deployed. Have the spoiler inspected as soon as possible by an authorized Audi dealer or qualified workshop.
- Improper operation of the rear spoiler can cause crushing injuries. Always make sure that nobody, especially children, is in the way when the rear spoiler is deployed or retracted.
- Always obey speed limits and other traffic laws.

Note

- Never push the vehicle or apply force to the rear spoiler – it could be damaged.
- Operate the rear spoiler manually only when the engine compartment lid is closed, otherwise there is a risk of damage. ►



Tips

Clean the spoiler compartment every 2 to 3 months. The spoiler compartment must always be free of ice, snow, leaves or other debris. ■

Braking

New brake pads

During the first 250 miles (400 km), new brake pads do not possess their full braking effect, they have to be "broken in" first. You can compensate for this slightly reduced braking power by pushing harder on the brake pedal. Avoid heavy braking loads during the break-in period.

Operating conditions and driving habits

The brakes on today's automobiles are still subject to wear, depending largely on operating conditions and driving habits ⇒ ⚠. On vehicles which are driven mostly in stop-and-go city traffic or which are driven hard, the brake pads should be checked by your authorized Audi dealer more often than specified in the **Warranty & Maintenance booklet**.

On steep slopes, you should use the braking effect of the engine. This way, you prevent unnecessary wear on the brake system. If you must use your brakes, do not hold the brakes down continuously. Pump the brakes at intervals.

Moisture or road salt

At speeds *above* 45 mph (70 km/h) and with the windshield wipers switched *on* (at least interval stage 4), the brake pads are briefly applied against the brake discs. This occurs at regular intervals without the driver noticing and provides for better brake response time under wet conditions.

Under certain conditions, for example, when driving through water or very heavy rain, or even after washing your vehicle, the braking

effect can be reduced due to moisture (or in freezing conditions ice) on the brake pads. A few cautious brake applications should dry off the brake pads or remove any ice coatings.

The effectiveness of the brakes can be reduced when the vehicle is driven on a salt-covered road and the brakes are not used. Likewise, you clean off accumulated salt coating from brake discs and pads with a few cautious applications of the brake ⇒ ⚠.

Corrosion

There may be a tendency for dirt to build up on the brake pads and corrosion to form on the discs if the car is not driven regularly or only for short trips with little use of the brakes.

If the brakes are not used frequently, or if corrosion has formed on the discs, it is advisable to clean off the pads and discs by braking firmly a few times from a moderately high speed ⇒ ⚠.

Faults in the brake system

If you should notice a *sudden* increase in brake pedal travel, then one of the two brake circuits may have failed. Drive immediately to the nearest qualified workshop to have the damage repaired. Drive at reduced speed on the way there and anticipate longer stopping distances and higher pedal pressure ⇒ ⚠.

Low brake fluid level

Malfunctions can occur in the brake system if the brake fluid level is too low. The brake fluid level is monitored electronically.

Brake power assist unit

The brake power assist unit increases the pressure that you generate with the brake pedal. It works only when the engine is running.



WARNING

- You should perform braking maneuvers for the purpose of cleaning the brake system only if road conditions permit. Other road users must not be put at risk - you may cause an accident!

⚠ WARNING (continued)

- Before descending a steep grade, reduce speed and shift transmission into a lower gear or lower driving position. Do not ride the brakes or hold the pedal down too long or too often. This could cause the brakes to get hot and diminish braking efficiency.
- Do not “ride the brakes” by resting your foot on the pedal when you do not intend to brake. This may cause the brakes to overheat, premature wear and increased stopping distance.
- Under certain climatic and operating conditions such as passing through water, driving in heavy rain or after washing the vehicle, the effectiveness of the brakes can be reduced. In winter, ice can accumulate on the brake pads, linings, discs and drums. Cautiously apply brakes for a test. Brakes will dry and ice coatings will be cleaned off after a few cautious brake applications.
- Driving for an extended period of time on salt-covered roads without using your brakes can also affect braking efficiency. Clean off accumulated salt coating from brake discs and pads with a few cautious brake applications.
- If you damage the front spoiler, or if you install a different spoiler, be sure the air flow to the front brakes is not obstructed. Otherwise the brake system could overheat reducing the effectiveness of the entire brake system.
- Failure of one brake circuit will impair braking capability, resulting in increased stopping distance. Avoid driving the vehicle and have it towed to the nearest authorized Audi dealer or qualified workshop.
- Never let the vehicle roll to a stop with the engine shut off.
- If the brake booster is not working, for example when towing your vehicle, or because the brake booster has somehow been damaged, the brake pedal must be pressed considerably harder to make up for the lack of booster assistance. ■

Power steering

When the engine is running, power steering makes it easier for the driver to steer.

Power steering helps the driver steer the vehicle with little physical effort .

If the engine is not running, the power steering system is also not working. In this case, you will find it extremely difficult to turn the steering wheel.

If you turn the steering *fully* to the left or right when the vehicle is stationary, you place a very heavy load on the power steering system. Turning the steering wheel fully to the left or right will cause noise in the system. It also reduces engine idle speed.

**Note**

Do not hold the steering turned fully to the left or right for more than 10 seconds when the engine is running. There is a risk of damage to the power steering system.

**Tips**

- In the event of a power steering system failure, or if the engine is not running (while being towed), you will still be able to steer the vehicle. However, you will require more effort to do so.
- If the power steering system has a leak or is defective, you should immediately contact a qualified workshop.
- The power steering system requires a special hydraulic fluid. The power steering fluid reservoir is located in the engine compartment. The correct hydraulic fluid level is important for proper operation of the power steering system. The power steering fluid level is checked according to the Audi maintenance service schedule. ■

Driving with your quattro®

With All Wheel Drive, all four wheels are driven.

General information

With All Wheel Drive, power is distributed to all four wheels. This happens automatically depending on your driving style and the road conditions at the time. See also ⇒ *page 164*.

Winter tires

When driving in the winter, your vehicle with All Wheel Drive has an advantage, even with regular tires. In winter road conditions it may be advisable to mount winter tires (or all-season tires) for improved driveability and braking: these tires must be mounted on **all four wheels**.

Snow chains

Where snow chains are mandatory on certain roads, this normally also applies to vehicles with All Wheel Drive ⇒ *page 221*, "Snow chains".

Replacing wheels/tires

Only the wheel/tire sizes specified by the manufacturer may be used on vehicles with all-wheel drive ⇒ *page 216*.

WARNING

- Always adjust your driving to road and traffic conditions. Do not let the extra safety afforded by All Wheel Drive tempt you into taking extra risks.
- Although All Wheel Drive is very effective, always remember that braking capacity is limited by tire traction. You should therefore not drive at excessive speeds on icy or slippery road surfaces.
- On wet road surfaces, be careful not to drive too fast because the front wheels could begin to slide on top of the water (aquaplaning). If this should occur, you will have no warning from a sudden increase in engine speed as with a front-wheel drive

WARNING (continued)

vehicle. Always drive at speeds which are suited to the road conditions. – risk of crash. ■

Dry sump lubrication

High lateral and longitudinal forces affect the engine and the vehicle during sporty driving. Dry sump lubrication ensures that your engine is supplied with oil and properly lubricated even under these conditions.

In a "normal" vehicle the oil pump sends the oil from the oil pan to the lubrication points in the engine. The oil then returns to the oil pan. In extreme situations, the oil pump may draw in air, which results in insufficient oil pressure.

With dry sump lubrication, the oil is not in the oil pan (it is "dry"), but in a separate oil tank. While one pump supplies the engine with oil, a second pump suctions the oil out of the engine and returns it to the oil tank. Because the oil tank is tall and narrow, oil pressure is constant even under extreme conditions.

In addition, the oil pan in vehicles with dry sump lubrication is noticeably shallower. This allows the engine to be installed lower in the vehicle, bringing down the center of gravity. This improves your vehicle's handling. ■

Driving and environment

Break-in period

A new vehicle must be broken in, and the break-in period should be 1,500 miles (2,500 km). Do not use full acceleration for the first 600 miles (1,000 km) and do not exceed the maximum engine speed of 6,000 rpm. You must also not use full acceleration between 600 and 1,200 miles (1,000 to 2,000 km). From 1,200 to 1,500 miles (2,000 to 2,500 km), you can gradually increase maximum engine speed to 8,250 rpm for brief periods.

During the first hours of operation, there is greater friction in the engine and the transmission than later when all the moving parts have broken in.

The way you drive during the first 1,500 miles (2,500 km) affects engine quality. If you drive at moderate engine speeds thereafter, particularly when the engine is cold, you reduce engine wear and increase the potential mileage of the engine.

Do not drive at RPMs that are too *low*. Shift down when the engine is no longer running “smoothly”. Extremely high RPMs are governed automatically. ■

Catalytic converter

You must use lead-free gasoline in your vehicle, otherwise you will destroy the catalytic converter.

Never run the fuel tank completely dry; the irregular fuel supply could cause misfires. This allows unburned fuel into the exhaust system, possibly resulting in overheating and damage to the catalytic converter.



WARNING

- Do not park or operate the vehicle in areas where the hot exhaust system may come in contact with dry grass, brush, fuel spills or other material which can cause a fire.
- Do not apply additional undercoating or rustproofing on or near the exhaust manifold, exhaust pipes, catalytic converter or heat shields. During driving, the substance used for undercoating could overheat and cause a fire.



Note

To ensure efficient operation of the Emission Control System:

- Have your vehicle maintained properly and in accordance with the service recommendations in your Warranty & Maintenance booklet.
- Lack of proper maintenance as well as improper use of the vehicle will impair the function of the Emission Control System and could lead to damage. ■

Sporty driving

Warming up and cooling down

By carefully warming up and cooling down your vehicle, you can help ensure that it is not overstressed unnecessarily during sporty driving.

When warming up, bring the engine oil up to a minimum temperature of 194°F (90 °C) at a maximum of 7,000 rpm. The tire traction will also improve after warming up under a load. ►

The cooling fan can continue to run in your vehicle after the engine is switched off. However, driving the vehicle to cool it down is particularly important. During sporty driving, the engine and brakes, the exhaust system, and the transmission all become extremely hot. Before you park the vehicle, you should drive it for a few miles/kilometers at light load in the low rpm range to allow it to cool down. ■

Driving on a track

Before you take your vehicle out on a track, ensure that it is in perfect condition. For example, you should check the tire tread and the brake pads. It is best to increase tire pressure by about 0.3 bar.

When driving on a track, oil consumption may be somewhat higher than in “normal” operation ⇒ *page 195*.

You should definitely inspect your vehicle after subjecting it to severe conditions. Are the brake pads OK? Is there anything unusual about the tires, including the inner and outer sidewalls (e.g. tread, blistering)? Are the air intakes free of leaves and tire dust? Is the oil level OK?

Your authorized Audi dealer or qualified workshop will be happy to undertake an inspection before and after use on the race track.

Tips

- Some race tracks (e.g. steeply banked turns) may affect the response of the ESP.
- When driven on a race track, all vehicle parts are severely stressed. This can result in increased wear. ■

Operation and maintenance

Fuel economy, environmental impact, and wear on your engine, brakes and tires largely depend on three factors:

- your personal driving style
- operating conditions
- technical limitations

By having your vehicle regularly serviced by an authorized Audi dealer helps to ensure that it runs properly and economically. The condition of your vehicle not only affects its safety and ability to hold its value, it also affects **fuel consumption**.

The amount of oil used is related to engine load and speed.

It is normal for the oil consumption of a new engine to reach its lowest value after a certain mileage has been driven.

You must drive your vehicle about 3.000 miles (5.000 kilometres) before you can properly assess oil consumption.

This also applies to fuel consumption and engine output.

Note

- Have your vehicle maintained properly and in accordance with the service recommendations in your Warranty & Maintenance booklet. Lack of proper maintenance as well as improper use of the vehicle will impair the function of the emission control system and could lead to damage.
- Do not alter or remove any component of the Emission Control System unless approved by the manufacturer.
- Do not alter or remove any device, such as heat shields, switches, ignition wires, valves, which are designed to protect your vehicle’s Emission Control System and other important vehicle components.

Tips

The consumption estimates as published by the ENVIRONMENTAL PROTECTION AGENCY (EPA) and Transport Canada may not correspond to your actual consumption on the road, which will vary ►

depending upon vehicle load and speed, road and weather conditions, trip length, etc. ■

Trailer towing

Your Audi R8 is not designed to tow a trailer.

Towing a trailer with your Audi R8 is not recommended and can cause damage to the vehicle. Damage caused by towing a trailer is not covered under warranty. ■





Cleaning and protection

General information

Regular care preserves vehicle value.

Regular and correct care will contribute to maintaining the beauty and value of your Audi. Furthermore, good care may be a condition for substantiating a warranty claim should corrosion damage or paint defects occur.

Your authorized Audi dealer has a variety of **dedicated vehicle-care products**. Please make sure you apply them correctly.

WARNING

- **Cleaning agents may be poisonous. Keep them out of the reach of children.**
- **Heed all caution labels.**
- **Always read directions on the container before using any product. Follow the directions carefully.**
- **Most chemical cleaners are concentrated and have to be diluted.**
- **Use spot removing fluids only in well ventilated areas.**
- **Do not use gasoline, kerosene, diesel fuel, nail polish remover or other volatile fluids. They may be toxic, flammable or hazardous in other ways. Do not wash, wax or dry the vehicle with the ignition on or the engine running.**
- **Do not clean the undersides of chassis, fenders, wheel covers, etc. without protecting your hands and arms. You may cut yourself on sharp-edged metal parts.**
- **Moisture and ice on brakes may impair braking efficiency ⇒ page 167, "Braking". Test the brakes carefully each time you wash the vehicle.**



For the sake of the environment

Select only environmentally friendly cleaning products. Leftover cleaning products should not be disposed of in the household waste. ■

Care of exterior

Washing your vehicle

The longer insect remains, bird droppings, tree resin, road and industrial dust, tar, soot particles, road salt, and other aggressive deposits remain on the vehicle surface, the more lasting their destructive effect will be. High temperatures, for example from intense sunlight, intensify the corrosive effect.

After the end of winter road salting, the **underside** of the vehicle should be thoroughly washed.

Automatic car washes

Before going through an automatic car wash, you should take the usual precautions (closing the windows). If your vehicle has special accessories - e.g. spoilers, radio antenna - it is best to speak to the operator of the car wash ⇒ .

Only use car washes where the vehicle remains stationary and the cleaning equipment moves around the vehicle while washing and drying. It is not possible to use car washes where the vehicle is moved forward on a conveyor ⇒ .

It is preferable to wash your vehicle in a brushless carwash.

Washing with a power washer

When washing your vehicle with a power washer, be sure to follow the operating instructions for the power washer. This applies particularly to the **pressure** and the **spraying distance**. Maintain sufficient ►

distance from soft materials such as rubber hoses, sound deadening material, and the parking aid sensors* that are located in the front or rear bumper.

Do not use washers with a **rotating jet** or a nozzle spraying a **high pressure jet** of water in any case.

Hand washing

When washing your vehicle by hand, first soften the dirt with copious amounts of water and rinse it off as best you can.

Then clean the vehicle using a soft **sponge**, an **auto glove** or a low-pressure **wash brush**. Work from the top down - starting with the roof. Use a **shampoo** only for very stubborn dirt.

Rinse the sponge or auto glove thoroughly at frequent intervals.

Clean the wheels, door sills and similar areas last. Use a separate sponge for this.

WARNING

- **Car washes with conveyors can damage the vehicle tires, which could cause the tire to lose pressure suddenly while driving and put you at risk for an accident. Do not use car washes with conveyors.**
- **Switch off the ignition when you wash your vehicle to avoid an accident.**
- **Protect your hands and arms from sharp metal edges when you clean the underbody, the inside of the wheel wells or the wheel covers to avoid cutting yourself.**
- **When washing your vehicle in the winter: Moisture and ice in the brake system can affect the brakes.**
- **Never wash tires with a jet that sprays water in a direct stream. This could cause invisible damage to the tires and weaken them, even if the spray is from a relatively long distance and for a short time. Damaged and weakened tires can fail and cause accidents and personal injury.**

Note

- Never drive your vehicle through any automatic car wash that fails to provide either sufficient clearance for your vehicle or sufficient track width for your tires. Risk of expensive damage to the vehicle's underbody, tires, and rims!
- As described in your Warranty & Maintenance booklet, damage or malfunction due to misuse of the vehicle or failure to operate the vehicle in accordance with the instructions of this Owner's Manual will not be covered under warranty.
- Fold the exterior mirrors flat - there is a risk of damaging the exterior mirrors. Power folding exterior mirrors must not be folded in or out by hand. Use the power function!
- Do not wash the vehicle in direct sunlight. You may damage the paint.
- Do not use sponges designed to remove insects, rough kitchen sponges, or similar products. You risk damaging the paint surface.
- Never clean the headlights with a dry cloth or sponge. Use a wet cloth or sponge. It is best to use soapy water.
- Never clean tires using a nozzle that sprays water in a direct stream. Damage can occur even with a relatively long spraying distance and for a very short time.
- To avoid damaging your vehicle, always make sure that there is sufficient distance between the spray head and soft materials like rubber hoses, plastic parts and sound-deadening materials. Never aim the spray head at the same point for a long time. This also applies to cleaning headlights and painted bumpers. Remember: the closer the nozzle is to the surface of the material, the greater the stress on the material.



For the sake of the environment

Wash your vehicle only at specially designed facilities. They can prevent any dirty water contaminated by oil from entering the waste water. In certain areas washing a car outside of such facilities is not permitted. ■

Waxing and polishing

Waxing

Waxing protects the paint. When water no longer clearly **beads** on the clean paint you should renew your vehicle's protection by applying a good **hard wax polish**.

Even if you regularly use a **wax process** in the car wash, we recommend protecting the paint at least twice per year using hard wax.

It is much easier to clean insects and other debris from *freshly* waxed paint.

Polishing

Polishing is necessary only if the paint on your vehicle has lost its shine and if you cannot achieve any gloss with wax materials.

If the polish you use does not contain any preservative ingredients, you will have to wax the paint afterwards.

WARNING

Always read and heed all **WARNING** and other Information

⇒ *page 176.*

Note

Do not treat matte anodized metal trim, plastic, or rubber parts with polish or wax. ■

Trim strips

For environmental reasons, Audi fabricates the bright trim strips and trim pieces from pure chromium-free aluminum.

Dirt and marks on the trim strips should be removed with a **pH-balanced** cleaning agent (do not use a chrome cleaner). Paint polishes are also not suitable for the care of decorative parts and

trim strips. Alkaline cleaners which are often used before entering car washes can cause dull or milky spots when they dry.

Authorized Audi dealers carry cleaning products which have been tested for use on your vehicle and are not harmful to the environment.

WARNING

Always read and heed all **WARNING** and other Information

⇒ *page 176.* ■

Plastic and vinyl

Use a clean, damp cloth or sponge to remove dust and light surface dirt. For other soil, use a lukewarm all-purpose cleaning solution or a mild saddle soap for vinyl trim. Paint care products are not suitable for plastic and vinyl.

WARNING

Always read and observe all **WARNINGS** and other information

⇒ *page 176.* ■

Applies to vehicles: with carbon-fiber

Carbon-fiber parts

The carbon-fiber parts of your vehicle have a painted surface. They do not require special care and are cleaned like other painted parts
⇒ *page 176.* ■

Touch-up paint

Your authorized Audi dealer has touch-up paint for minor scratches and stone chips. Minor paint damages such as scratches or stone chips should be touched up immediately to prevent corrosion.

The number for the original vehicle paint can be found on the vehicle identification label ⇒ *page 252*.

However, if corrosion has formed, you must have this thoroughly removed by you authorized Audi dealer or other qualified workshop.

WARNING

Always read and heed all WARNINGS and the information
⇒ *page 176*. ■

Windows

Clear vision improves traffic safety.

In order to maintain the performance of the windshield wiper blades, never clean the window glass with insect remover or wax.

Rubber, oil, grease, or silicone residue can be removed using a **glass cleaner** or a **silicone remover**. Wax residue, however, can only be removed using a special cleaner. You can obtain more information from your authorized Audi dealer.

You should also clean the inside of the window glass at regular intervals.

The cloth or chamois used on paint surfaces contains wax residue. Use a separate cloth or chamois to dry the window glass.

WARNING

• **The windshield must not be treated with water-repellent materials. They can increase glare under poor visibility conditions such**

WARNING (continued)

as wetness, darkness, or when the sun is low on the horizon. In addition, they can cause the windshield wipers to chatter.

• **Always read and heed all WARNINGS and other information**
⇒ *page 176*.

Note

- Never use warm or hot water to remove snow and ice from windows and mirrors. This could cause the glass to crack.
- To prevent damage to the wires of the rear defogger, do not place any adhesive stickers on the inside of the rear window over the wires.
- To help prevent dirt from scratching the window, always scrape in a forward direction - pushing the scraper away from you - never back and forth. ■

Weatherstrips

To seal properly, the weatherstrips around the front lid, doors, engine compartment lid, etc. must remain pliable. Spray the weatherstrips with silicone or coat them with talcum powder or glycerine to retain the flexibility of the rubber and to protect them against freezing in the winter.

WARNING

Always read and heed all WARNINGS and the information
⇒ *page 176*.

Tips

Keep silicone sprays off the windshield to avoid wiper smear in rain. ■

Wheels

Regular care is required to preserve the decorative appearance of the wheels. Road salt and brake dust must be washed off regularly or the wheels will be damaged.

Use only special acid-free cleaning agents. You can find proper wheel cleaner at authorized Audi dealers and specialty stores. Do not leave the cleaner on the wheels longer than specified. Wheel cleaners containing acid can damage the surface of the wheel bolts.

Paint polish or other abrasive materials must not be used when caring for wheels. If the protective coating has been damaged, from stones for example, touch up the damage as soon as possible.

WARNING

- **Moisture and ice on brakes may affect braking efficiency** -
⇒ *page 167, "Braking"*. Test the brakes carefully after each vehicle wash.
- **Always read and heed all WARNINGS and the information**
⇒ *page 176.* ■

Care of interior

Plastic parts and imitation leather

You can clean plastic parts and imitation leather with a damp cloth. If this does not remove the dirt, you can treat these parts only with special **solvent-free plastic cleaning and care products**.

WARNING

Solvents can change the properties of some plastics and make it harder for the airbag to deploy.

WARNING (continued)

- **Never clean the instrument panel or the surface of Airbag modules with cleaning products that contain solvents.**
- **Products containing solvents will make the surface of this part porous.**
- **Serious injuries can result if plastic parts come loose when the airbag is deployed.**
- **Always read and heed all WARNINGS and the information**
⇒ *page 176.*

Note

Cleaning agents containing solvents will attack the material and can change the way it behaves. ■

Applies to vehicles: with carbon-fiber

Carbon-fiber parts

The carbon-fiber parts of your vehicle have a painted surface. They do not require any special care and are cleaned like plastic parts
⇒ *page 180.* ■

Fabrics and fabric coverings

Fabrics and fabric coverings (e.g. seats, door trim panels, etc.) should be cleaned at regular intervals with a vacuum cleaner. This removes surface dirt particles which could become embedded in the fabric through use. Steam cleaners should not be used, because the steam tends to push the dirt deeper into the fabric and lock it there.

Normal cleaning

Generally, we recommend using a soft sponge or a lint-free microfiber cloth to clean the fabric. Brushes should only be used for ►

carpets and floor mats, since other fabric surfaces could be harmed by brushes.

Normal surface stains can be cleaned using a commercially available foam cleaner. Spread the foam on the surface of the fabric with a soft sponge and work it in gently. Do not saturate the fabric. Then pat the foam dry using absorbent, dry cloths (e.g. microfiber cloth) and vacuum it after it has dried completely.

Cleaning stains

Stains caused by beverages (e.g. coffee, fruit juice, etc.) can be treated with a mild detergent solution. Apply the detergent solution with a sponge. In the case of stubborn stains, a detergent paste can be applied directly to the stain and worked into the fabric. Afterwards, use copious amounts of clean water to remove the remaining detergent. Apply the water with a damp cloth or sponge and pat the fabric dry with an absorbent, dry cloth.

Stains from chocolate or makeup should have detergent paste (e.g. ox-gall soap) rubbed into them. Afterwards, remove the soap with water (damp sponge).

Alcohol can be used to treat stains from grease, oil, lipstick or a ball-point pen. Melted grease or dye must be patted off using absorbent material. It may be necessary to retreat the areas with detergent paste and water.

In the case of general soiling of the upholstery and cover material, we recommend hiring a specialist that has the equipment to clean the seat covers and other fabric surfaces by shampooing and spray extraction.

WARNING

Always read and heed all WARNINGS and the information
⇒ *page 176.*

Tips

Open Velcro fasteners on your clothing can damage the seat cover. Please make sure that Velcro fasteners are closed. ■

Applies to vehicles: with natural leather

Natural leather

Audi makes great efforts to maintain the properties, natural look and feel of interior leather.

General

We offer many different types of leather on our vehicles. Most are different types of nappa leather, which has a smooth surface and comes in various colors.

The intensity of the color determines the visual characteristics and appearance. If the surface of the leather has a typical natural look, then the leather is a nappa leather that has been left in a relatively natural condition. This leather offers particularly good comfort and breathes well. Fine veins, closed grains, insect bites, skin folds, and subtle variations in color remain visible. These characteristics demonstrate that the material is natural.

Natural nappa leather is not covered by a color finish. It is therefore more sensitive to soiling and wear, which is something you need to consider if children, animals or other factors might prove to be particularly hard on the leather.

By contrast, leather types that are covered by a colored finish layer are more durable. This has a positive effect on the leather's resistance to wear and soiling in daily use. On the other hand, the typical characteristics of natural leather are barely or not apparent. However, this does not mean that the leather itself is of inferior quality.

Care and handling

Because of the exclusive nature of the types of leather that Audi uses and their unique properties (such as sensitivity to oils, grease, ►

soiling, etc.), you will need to be somewhat careful with these leathers, and a certain type of care is required. For example, dark clothing materials can discolor leather seats (especially if such clothing is damp and was not dyed correctly). Dust and dirt particles in pores, folds, and seams can have an abrasive effect and can damage the leather surface as well as weaken seams.

The leather should be cleaned regularly as needed. After having been used for a relatively long time, your leather seats will acquire a rich aged finish. This is a characteristic of natural leather and a sign of true quality.

In order to maintain the value of this natural product over the life of your vehicle, you should follow the recommendations below:



Note

- To keep your leather from bleaching out, do not allow it to be exposed to bright sunlight for long periods of time. If you have to leave the vehicle parked outside for long periods, cover the leather to protect it from direct exposure to sunlight.
- Sharp objects on clothing, such as zippers, rivets or sharp pieces on belts can leave permanent scratches or scrape marks on the surface of the leather.



Tips

- After each time you clean the leather and at regular intervals, use a leather preservative creme that contains UV-blockers and that works into the leather. This creme will nourish and moisturize the leather, helping it to breathe and stay supple. It also helps to build up a protective coating on the surface.
- Clean the leather every 2 - 3 months, and clean any areas that get soiled.
- Remove fresh marks made by ballpoint pens, ink, lipstick, shoe polish, etc. as soon as possible.
- Preserve the color of the leather as needed by using a special colored leather care creme to touch up areas of uneven color. ■

Applies to vehicles: with natural leather

Cleaning and caring for leather upholstery and trim

Natural leather requires special care and attention.

Normal cleaning

- Clean soiled areas with a slightly moistened cotton or woolen cloth.

More stubborn dirt

- More stubborn dirt can be removed using a cloth saturated with a mild soap solution (2 tablespoons mild liquid soap).
- Never allow the soap solution to saturate the leather, and make certain that no water soaks into the seams.
- Wipe off the soap solution with a soft, dry cloth.

Cleaning spots

- Remove fresh **water-based** spots (such as coffee, tea, juices, blood) with an absorbent cloth or paper towel.
- Remove fresh **grease or oil-based spots** (such as butter, mayonnaise, chocolate) with an absorbent cloth or paper towel, or use the cleaner from the leather care kit if the spot has not yet penetrated into the surface of the leather.
- Use an oil/grease dissolving spray, if **oil/grease spots have dried on**.
- Remove specific kinds of spots (ballpoint pen, felt marker, fingernail polish, water-based paint, shoe polish, etc.) with a spot remover specifically formulated for leather. ▶

Leather care

- Every half year use an approved leather care product (available from your authorized Audi dealer) to care for the leather.
- Apply the product very sparingly.
- Wipe it off with a damp cloth.

If you have any questions about cleaning and caring for the leather in your vehicle, it is best to contact your authorized Audi dealer, who will be glad to help you and tell you about our full range of leather care products, such as:

- Leather cleaning and care kit
- Cremes to care for colored leather
- Spot removers for ballpoint pens, shoe polish, etc.
- Oil/grease dissolving spray
- New and upcoming products.

WARNING

Always read and heed all **WARNINGS** and the information
⇒ *page 176*.

Note

- Never use chemical solvents (e.g. lighter fluid, turpentine), waxes, shoe polish or similar products on the leather surfaces in your Audi.
- To avoid damage, have stubborn stains removed by a commercial cleaning specialist. ■

Applies to vehicles: with Alcantara upholstery

Cleaning Alcantara® (synthetic suede)

Removing dust and dirt

- Moisten a cloth, *squeeze out excess water* and wipe down the seat surfaces.

Removing stains

- Moisten a cloth with lukewarm water or with diluted **ethyl (rubbing) alcohol**.
- Dab at the stain. Start at the outside and work inwards.
- Once the stain is no longer visible, use a soft dry cloth or tissue to soak up the moisture.

Do not use leather cleaning products on Alcantara.

You may use a suitable shampoo for removing dust and dirt.

Dust and grit in the pores and seams can scratch and damage the surface. If the car is left standing in the sun for long periods, the leather should be protected against direct sunlight to prevent it from fading. Slight color variations will develop in normal use and are not an indication of material deterioration.

Note

- Never use chemical solvents (e.g. lighter fluid, turpentine), waxes, shoe polish or similar products on Alcantara® surfaces.
- To avoid damage, have stubborn stains removed by a commercial cleaning specialist.
- Do not use brushes, stiff sponges or similarly abrasive cleaning aids. ■

Safety belts

Heavily soiled safety belts may not retract properly.

- Keep belts clean.
- For cleaning, use a mild soap and water solution. Let belts dry thoroughly and away from direct sunlight.
- Do not allow inertia reel safety belts to retract before they are completely dry.
- Check the condition of your safety belts *regularly*.

WARNING

Damaged safety belts can break in a crash.

- Anything that might damage your safety belts could mean that you and your passengers would not be adequately protected in an accident.
- Safety belt performance depends on correct installation. Never remove belts from the vehicle to clean them.
- Do not use chemical cleaning agents, bleach or dyes. They have corrosive properties which weaken the webbing.
- When cleaning your safety belts, inspect them for damage. If you discover damage, see your authorized Audi dealer.
- Always read and heed all WARNINGS and the information ⇒ *page 176*. ■

Engine compartment

Be especially careful when cleaning the engine compartment.

Corrosion protection

The engine compartment and transmission have been corrosion-protected at the factory.

Good anti-corrosion treatment is very important, particularly in the winter. If the vehicle is frequently driven on salt treated roads, the entire engine compartment and plenum panel should be thoroughly cleaned at the end of winter and retreated to prevent salt damage. At the same time, the underside of the vehicle should be washed as well.

If the engine compartment is cleaned at any time with grease removing solutions¹⁾, or if you have the engine washed, the anti-corrosion treatment is almost always removed as well. It is therefore essential to have a long-lasting corrosion protection reapplied to all surfaces, seams, joints and components in the engine compartment.

WARNING

Be aware: The engine compartment of any motor vehicle is a potentially hazardous area.

- Before working in the engine compartment, be sure to read the information ⇒ *page 191*.
- Before reaching into the front plenum panel, always remove the ignition key. Otherwise, the windshield wiper system could unintentionally be switched on, possibly causing personal injury from the moving wiper linkage.
- Never reach into the area around or touch the radiator fan. The auxiliary fan is temperature controlled and can switch on suddenly - even when the ignition is off. ▶

¹⁾ Use only the correct cleaning solutions. Never use gasoline or diesel fuel.

 **WARNING (continued)**

- Do not wash, wax or dry the engine with the engine running. Moving or hot parts could injure you.
- Do not clean the underside of the chassis, fenders, wheel covers, or other hard to reach parts without protecting your hands and arms. You may cut yourself on sharp-edged metal parts.
- Always read and heed all WARNINGS and other information ⇒ *page 176.* ■

Fuel supply and filling your fuel tank

Gasoline

Fuel supply

Using the right fuel helps keep the environment clean and prevents engine damage.

Fuel recommendation

The fuel recommended for your vehicle is **unleaded premium** grade gasoline. See also ⇒ *page 254, "Data"*. Audi recommends using TOP TIER Detergent Gasoline with a minimum octane rating of 91 AKI (95 RON). For more information on TOP TIER Detergent Gasoline, please go to the official website (www.toptiergas.com).

The recommended gasoline octane rating for your engine can also be found on a label located on the inside of the fuel filler flap. This rating may be specified as AKI or RON.

Your vehicle may also be operated using unleaded regular gasoline with a minimum octane rating of 87 AKI/91 RON. However, using 87 AKI/91 RON octane fuel will slightly reduce engine performance.

Use unleaded gasoline only. Unleaded gasoline is available throughout the USA, Canada, and in most European countries. We recommend that you do not take your vehicle to areas or countries where unleaded gasoline may not be available.

For more information on refueling your vehicle, see ⇒ *page 187*.

Octane rating

Octane rating indicates a gasoline's ability to resist engine damaging "knock" caused by premature ignition and detonation. Therefore, buying the correct grade of gasoline is very important to help prevent possible engine damage and a loss of engine performance.

Gasoline most commonly used in the United States and Canada has the following octane ratings that can usually be found on the filler pump:

- Premium Grade: 91 - 96 AKI
- Regular Grade: 87 - 90 AKI

Explanation of the abbreviations:

AKI = **A**nti **K**nock Index = $(R+M)/2 = (RON+MON)/2$

RON = **R**esearch **O**ctane **N**umber

MON = **M**otor **O**ctane **N**umber.

Note

- Do not use any fuel with octane ratings lower than 87 AKI or 91 RON otherwise expensive engine damage will occur.
- Do **not** use leaded gasoline! The use of leaded gasoline will severely damage your vehicle's catalytic converter and its ability to control exhaust emissions. ■

Blended gasoline

Use of gasoline containing alcohol or MTBE (methyl tertiary butyl ether)

You may use unleaded gasoline blended with alcohol or MTBE (commonly referred to as oxygenates) if the blended mixture meets the following criteria:

Blend of gasoline methanol (wood alcohol or methyl alcohol)

- Anti-knock index must be 87 AKI or higher.
- Blend must contain no more than 3% methanol.
- Blend must contain more than 2% co-solvents.

Blend of gasoline and ethanol (grain alcohol or ethyl alcohol)

- Anti-knock index must be 87 AKI or higher.
- Blend must not contain more than 10% ethanol.

Blend of gasoline and MTBE

- Anti-knock index must be 87 AKI or higher.
- Blend must contain not more than 15% MTBE.

Seasonally adjusted gasoline

Many gasoline grades are blended to perform especially well for winter or summer driving. During seasonal change-over, we suggest that you fill up at busy gas stations where the seasonal adjustment is more likely to be made in time.

 **Note**

- Methanol fuels which do not meet these requirements may cause corrosion and damage to plastic and rubber components in the fuel system.
- Do not use fuels that fail to meet the specified criteria in this chapter.
- If you are unable to determine whether or not a particular fuel blend meets the specifications, ask your service station or its fuel supplier.
- Do not use fuel for which the contents cannot be identified.
- Fuel system damage and performance problems resulting from the use of fuels different from those specified are not the responsibility of Audi and are not covered under the New Vehicle or the Emission Control System Warranties.
- If you experience a loss of fuel economy or driveability and performance problems due to the use of one of these fuel blends, we recommend that you switch to unblended fuel. ■

Gasoline additives

A major concern among many auto manufacturers is carbon deposit build-up caused by the type of gasoline you use.

Although gasoline grades differ from one manufacturer to another, they have certain things in common. All gasoline grades contain substances that can cause deposits to collect on vital engine parts, such as fuel injectors and intake valves. Although most gasoline brands include additives to keep engine and fuel systems clean, they are not equally effective.

Audi recommends using TOP TIER Detergent Gasoline. For more information on TOP TIER Detergent Gasoline, please go to the official website (www.toptiergas.com).

After an extended period of using inadequate fuels, built-up carbon deposits can rob your engine of peak performance.

 **Note**

Damage or malfunction due to poor fuel quality is not covered by the Audi New Vehicle Limited Warranty. ■

Fuel tank**Fuel filler neck**

The fuel filler neck is located on the right rear side panel behind the fuel filler flap.

If the unlocking system should fail, you can still open the flap manually - for detailed instructions see ⇒ *page 190*.

You can find the fuel tank capacity of your vehicle in **Technical Data** ⇒ *page 254*. ▶

The label on the inside of the fuel filler flap tells you the correct fuel for your vehicle. For more information about fuel specifications, see ⇒ page 186.

Your vehicle fuel tank has an on-board refueling vapor recovery system. This feature helps to prevent fuel vapors from escaping from the tank and polluting the environment while you refuel your vehicle. In order to fill the tank properly while protecting the environment, please follow this refueling procedure carefully.

WARNING

Under normal operating conditions, never carry additional fuel containers in your car. Gas canisters and other containers used to transport fuel can be dangerous. Such containers, full or empty, may leak and could cause a fire in a collision. If you must transport fuel to use for your lawn mower, snow blower, etc., be very careful and always observe local and state laws regarding the use, transportation and storage of such fuel containers. Make certain the container meets industry standards (ANSI/ASTM F852 - 86).

Note

Never drive your vehicle until the fuel tank is completely dry. The irregular supply of fuel can cause misfiring. Gasoline could enter into the exhaust system and damage the catalytic converter. ■

Refueling



Fig. 114 Driver's door: Unlocking fuel filler flap



Fig. 115 Fuel cap hooked on the opened fuel filler flap

When adding fuel, the ignition and any cellular phones in the vehicle must be switched *off*.

Taking the fuel cap off

- To open the fuel filler flap, press the button ⇒ fig. 114.
- Unscrew fuel filler cap counter-clockwise and hang it on the fuel filler flap ⇒ fig. 115.

Refueling procedure

- Insert the fuel nozzle from the gasoline pump into the fuel filler neck as far as it will go. ▶

- Select a medium refueling rate so that the nozzle switches off automatically when the tank is full.

Putting the fuel cap back on

- After filling your tank, twist the fuel filler cap clockwise until you hear a definite click.
- Close the fuel filler flap.

To avoid fuel spilling or evaporating from the fuel tank always close fuel filler cap properly and completely. An improperly closed fuel filler cap may also cause the MIL lamp ⇒ *page 24* to come on.

WARNING

Improper refueling or handling of fuel can cause fire, explosion and severe burns.

- Fuel is highly flammable and can cause severe burns and other injuries.
- Failure to shut the engine off while refueling and/or to insert the pump nozzle fully into the fuel filler neck could cause fuel to spray out of filler neck or to overflow. Fuel spray and overflowing fuel can cause a fire.
- Never use a cellular telephone while refueling. The electromagnetic radiation can cause sparks that can ignite fuel vapors and cause a fire.
- Never get back into your vehicle while refueling. If in exceptional circumstances you must get back in your vehicle while refueling, make certain that you close the door and touch metal to discharge static electricity before touching the filler nozzle again. Static electricity can cause sparks that can ignite fuel vapors released during refueling.
- Never smoke or have an open flame anywhere in or near your vehicle when refueling or filling a portable fuel container.

WARNING (continued)

- For your safety, we strongly recommend that you do not travel with a portable fuel container in your vehicle. The container, full or empty may leak and could cause a fire, especially in a crash.
- If, under exceptional circumstances, you must transport a portable fuel container, please observe the following:
 - Never fill a portable fuel container while it is anywhere in or on the vehicle (for example, in the luggage compartment, or on the trunk). Static electricity can build up while filling and can ignite fuel vapors causing a fire.
 - Always place a portable fuel container on the ground before filling.
 - Always keep the filler nozzle completely inside the portable container before and during filling.
 - If filling a portable container made of metal, the filler nozzle must always be in contact with the container. This will help prevent static electricity from discharging and cause a fire.
 - Never spill fuel inside the vehicle or luggage compartment. Fuel vapors are highly flammable.
 - Always observe local and state/provincial laws regarding the use, storage and transportation of fuel containers
 - Make certain the fuel container meets industry standards (ANSI / ASTM F852–86).

Note

If any fuel has spilled onto the car, it should be removed immediately to prevent damage to the paint.

For the sake of the environment

As soon as the correctly operated nozzle switches off automatically for the first time, the tank is full. Do not try to add more fuel because fuel may spill out. In addition, the expansion space in the fuel tank ►

will be filled - causing the fuel to overflow when it becomes warm and pollute the environment.

Tips

- Running your engine while refueling may cause vapors to escape or even fuel to spill out of the tank. This would then shut off the fuel nozzle before the tank is full.
- Do not refuel your vehicle with the ignition switched on. The fuel gauge may otherwise not indicate the correct fuel level after refueling. ■

- Pull the red plastic cord to the left until the fuel filler flap opens. ■

Unlocking the fuel filler flap by hand

You can open the fuel filler flap by hand if the power locking system should fail.

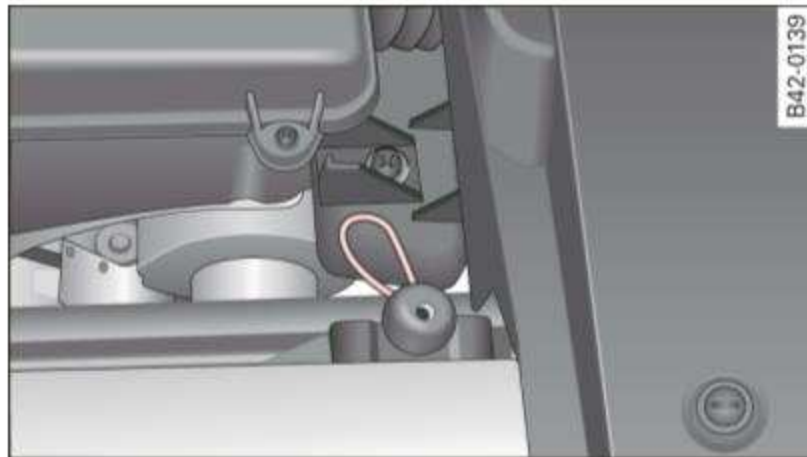

Fig. 116 Engine compartment: Emergency release

- Open the engine compartment lid.
- Open the latch for the right-side engine compartment panel.
- Lift the engine compartment panel slightly. There is a red plastic cord under the engine compartment panel.

Checking and filling

Engine compartment lid

Releasing the engine compartment lid

The engine compartment lid is released from inside the vehicle.

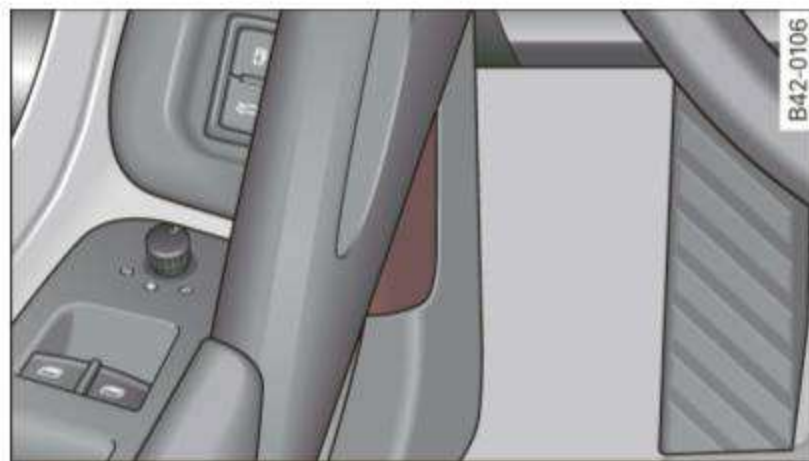

Fig. 117 Driver's side footwell: engine compartment lid release lever

- Open the driver's door.
- Make sure that the rear spoiler is retracted ⇒ *page 166*.
- Pull the release lever on the left under the instrument panel ⇒ *fig. 117*.
- Open the engine compartment lid ⇒

The engine compartment lid is held open by two gas struts.

WARNING

Hot engine coolant can burn you.

- To reduce the risk of being burned, never open the engine compartment lid if you see or hear steam or coolant escaping from the engine compartment. Wait until no steam or coolant can be

WARNING (continued)

seen or heard before carefully opening the engine compartment lid. ■

Working in the engine compartment

Be especially careful whenever you work in the engine compartment!

Whenever you must perform any work in the engine compartment, for example checking and filling the different fluids, there is a risk of injury, burns and accidents. To prevent personal injury always observe the following WARNINGS. The engine compartment of any vehicle is a hazardous area! ⇒

WARNING

To help avoid injury, before you check anything under the engine compartment lid:

- Switch off the engine.
- Remove the ignition key.
- Apply the parking brake.
- Move selector lever of R tronic to "N" (Neutral); put manual transmission in Neutral.
- Always let the engine cool down. Hot components will burn skin on contact.
- To reduce the risk of being burned, never open the engine compartment lid if you see or hear steam or coolant escaping from the engine compartment. Wait until no steam or coolant can be seen or heard before carefully opening the engine compartment lid.
- Keep children away from the engine compartment.

 WARNING (continued)

- Never spill fluids on hot engine components. They can cause a fire.
- Never open the coolant reservoir cap when the engine is still warm. The coolant system is pressurized and hot coolant could spray out.
- Protect your face, hands and arm from steam or hot engine coolant by placing a thick rag over the cap when you open the coolant reservoir.
- If work on the fuel system or the electrical system is necessary:
 - Always disconnect the battery.
 - Never smoke or work near heaters or open flames. Fluids in the engine compartment could start a fire.
 - Keep an approved fire extinguisher immediately available.
- To avoid electrical shock and personal injury while the engine is running or being started, never touch:
 - Ignition cables
 - Other components of the high voltage electronic ignition system.
- If you must perform a check or repair with the engine running:
 - First, fully apply the parking brake, move selector lever of R tronic to “N” (Neutral); put manual transmission in Neutral.
 - Always use extreme caution to prevent clothing, jewelry, or long hair from getting caught in the radiator fan, V-belts or other moving parts, or from contacting hot parts. Tie back hair before starting, and wear no clothing that will hang or droop into the engine.
- Minimize exposure to emission and chemical hazards ⇒ .

 WARNING

California Proposition 65 Warning:

 WARNING (continued)

- Engine exhaust, some of its constituents, and certain vehicle components contain or emit chemicals known to the State of California to cause cancer and birth defects and reproductive harm. In addition, certain fluids contained in vehicles and certain products of component wear contain or emit chemicals known to the State of California to cause cancer and birth defects or other reproductive harm.
- Battery posts, terminals and related accessories contain lead and lead compounds, chemicals known to the State of California to cause cancer and reproductive harms. Wash hands after handling.

 Note

When adding fluids, always make sure that they are poured into the proper container or filler opening, otherwise serious damage to vehicle systems will occur.

 For the sake of the environment

To detect leaks in time, inspect the vehicle floor pan from underneath regularly. If you see spots from oil or other vehicle fluids, have your vehicle inspected by an authorized Audi dealer. ■

Closing the engine compartment lid

- Make sure that the rear spoiler is retracted ⇒ *page 166*.
- Pull the engine compartment lid down until the pressure from the struts is reduced.
- Let the engine compartment lid *drop down* and latch in place. *Do not try to push it shut*; it may fail to engage ⇒ .

! WARNING

A engine compartment lid that is not completely latched could fly up and block your view while driving.

- When you close the engine compartment lid, check it to make sure the safety catch has properly engaged. The engine compartment lid should be flush with the surrounding vehicle body parts.
- If you notice while driving that the engine compartment lid is not secured properly, stop at once and close it. ■

Engine compartment

These are the most important items that you can check.

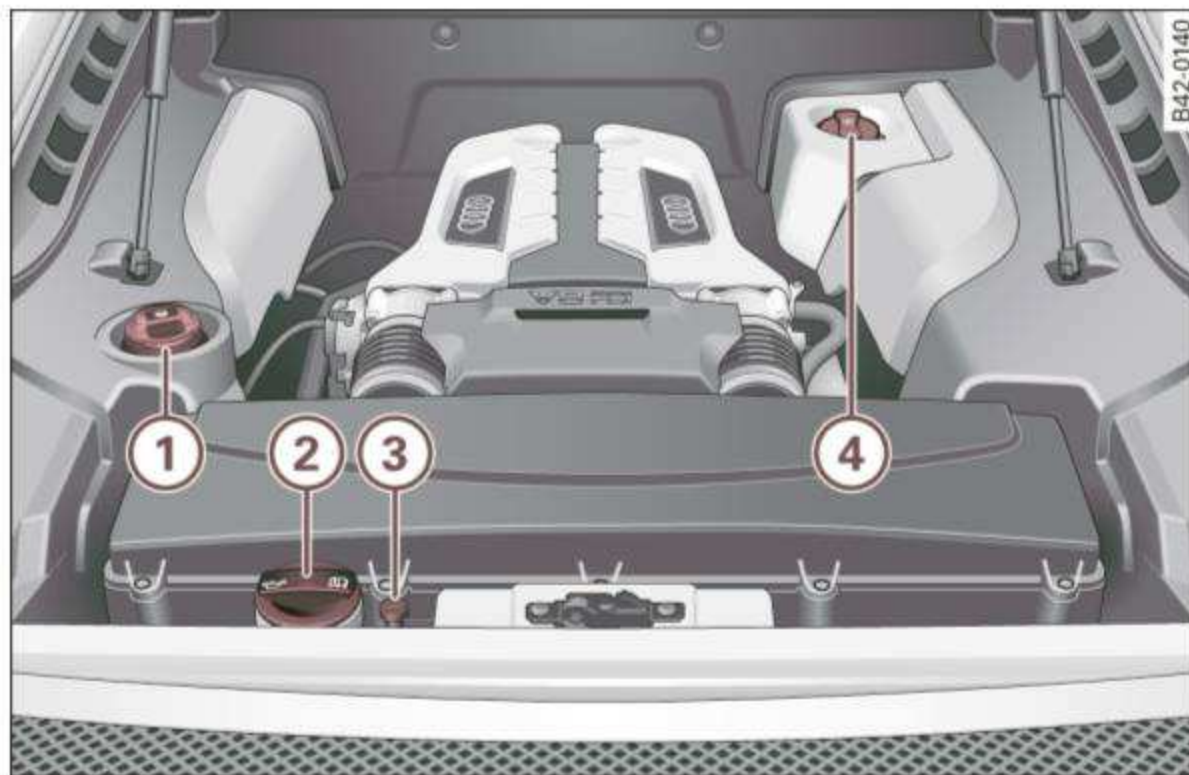

Fig. 118 Typical layout for containers, engine oil dipstick and engine oil filler cap

- ① Power steering fluid reservoir. 168
- ② Engine oil filler cap (🛢️) 196

- ③ Engine oil dipstick 195
- ④ Coolant expansion tank (🚰) 198

! WARNING

Before you check anything in the engine compartment, always read and heed all WARNINGS ⇒ **!** in “Working in the engine compartment” on *page 191*. ■

Engine oil

Engine oil specifications

The engine oil used in your Audi needs the right kind of oil.

The engine in your Audi is a sophisticated powerplant that was built to exacting specifications. This engine needs the right kind of engine oil that meets specifications regarding quality and viscosity so that it can run smoothly and reliably. Choosing the right oil and changing oil within the time and mileage intervals printed in your vehicle’s Warranty & Maintenance booklet matters a lot more today than it did years ago. Audi has developed a special quality standard for engine oil that will help assure that your vehicle’s engine will get the lubrication it needs for proper operation.

Modern engine lubrication has taken a quantum leap in the last few years. Many synthetic oils available today provide better engine lubrication that can outlast traditional petroleum-based oils, making them a smart choice for use throughout the life of your Audi.

Whether you use synthetic or petroleum-based engine oil, the oil that you use must conform to Audi’s oil quality standard VW 502 00 to help keep your vehicle’s engine running smoothly and help prevent the formation of harmful deposits, sometimes called “sludge,” that over time can lead to expensive repairs. ▶

At the time of printing, engine oils available in the U.S. and Canada that meet the exacting specifications of Audi oil standard VW 502 00 are synthetic engine oils. This does not mean, however, that every synthetic engine oil will meet Audi oil standard VW 502 00. So always be sure that you use an approved oil.

To help prevent the formation of harmful deposits use only oil with the following specifications printed on the oil container:

Audi oil standard VW 502 00

Oil container labels may carry the specification singly or in combination with other designations and oil quality standards.

Viscosity

Engine oils are graded according to their viscosity. The proper viscosity grade oil for your engine depends on climactic or seasonal conditions where you drive. You can use oil with a viscosity grade of SAE 5W40 across all temperature ranges for normal driving conditions.

However, if engine oil viscosity grade SAE 5W40 is not available, you can also use viscosity grade SAE 5W-30 or SAE 0W-40 as long as it meets Audi oil quality standard VW 502 00 specifications.

Because engine oil that meets the Audi oil standard may not be available everywhere when you need it, we strongly recommend that you always carry with you an extra quart (liter) of oil that expressly conforms to the VW 502 00 specification, in case you have to top off the oil while on the road.

Only if the level of the oil is at or below the minimum mark on the oil dipstick - and no oil that expressly conforms to Audi oil standard VW 502 00 specifications is available - may you top off with a high quality engine oil, preferably synthetic-based, that meets ACEA A3, ACEA A5 or ACEA B5, API SL or ILSAC GF-3 specifications, but even then, only in viscosity grades SAE 5W-40, SAE 5W-30, or SAE 0W-40. However, during the entire time between oil change intervals, never top off with more than a total of 0.5 qt/liter engine oil that does not conform to Audi oil specification VW 502 00.

For more information about engine oil that has been approved for your vehicle, please contact either your authorized Audi dealer or Audi Customer Relations at 1 (800) 822-2834 or visit our web site at www.audiusa.com or www.audicanada.ca. Here you will also find a current list of oils (manufacturers, brand names etc.) that conform to Audi oil standard VW 502 00.

Changing the engine oil

The engine oil and oil filter must be changed according to the mileage (kilometers) and time intervals specified in your vehicle's Warranty & Maintenance booklet. Do not exceed these intervals – harmful deposits from old engine oil can reduce engine performance and can lead to expensive engine repairs.

Changing the oil at the recommended intervals is so very important because the lubricating properties of oil decrease gradually during normal vehicle use. If you are not sure when you have your oil changed, ask your authorized Audi Service Advisor.

Under some circumstances the engine oil should even be changed more frequently. Change oil more often if you drive mostly short distances, operate the vehicle in dusty areas or mostly under stop-and-go traffic conditions, or when you use your vehicle where temperatures stay below freezing point for long periods.

Detergent additives in the oil will make fresh oil look dark after the engine has been running for a short time. This is normal and is not a reason to change the oil more often than recommended.

Damage or malfunctions due to lack of maintenance

It is essential that you change your oil at the recommended intervals using only engine oil that complies with Audi oil standard VW 502 00. Your Limited New Vehicle Warranty does not cover damage or malfunctions due to failure to follow recommended maintenance and use requirements as set forth in the Audi Owner's Manual and Warranty & Maintenance booklet. Your authorized Audi dealer will have to deny warranty coverage unless you present to the dealer proof in the form of Service or Repair Orders that all scheduled maintenance was performed in a timely manner. ■

Engine oil consumption

The engine in your vehicle depends on an adequate amount of oil to lubricate and cool all of its moving parts.

In order to provide effective lubrication and cooling of internal engine components, all internal combustion engines consume a certain amount of oil. Oil consumption varies from engine to engine and may change significantly over the life of the engine. Typically, engines with a specified break-in period (see ⇒ *page 170*) consume more oil during the break-in period than they consume after oil consumption has stabilized.

Under normal conditions, the rate of oil consumption depends on the quality and viscosity of the oil, the RPM (revolutions per minute) at which the engine is operated, the ambient temperature and road conditions. Further factors are the amount of oil dilution from water condensation or fuel residue and the oxidation level of the oil. As any engine is subject to wear as mileage builds up, the oil consumption may increase over time until replacement of worn components may become necessary.

With all these variables coming into play, no standard rate of oil consumption can be established or specified. There is no alternative to regular and frequent checking of the oil level, see **Note**.

If the yellow engine oil level warning symbol in the instrument cluster  lights up, you should top off 1 quart (1 liter) oil ⇒ *page 196*.

WARNING

Before you check anything in the engine compartment, always read and heed all WARNINGS ⇒  in "Working in the engine compartment" on *page 191*.

Note

Driving with an insufficient oil level is likely to cause severe damage to the engine.

Tips

If you have the impression your engine consumes excessive amounts of oil, we recommend that you consult your authorized Audi dealer to have the cause of your concern properly diagnosed. Keep in mind that the accurate measurement of oil consumption requires great care and may take some time. Your authorized Audi dealer has instructions about how to measure oil consumption accurately. ■

Checking the engine oil level



Fig. 119 Instrument cluster: Engine oil temperature display

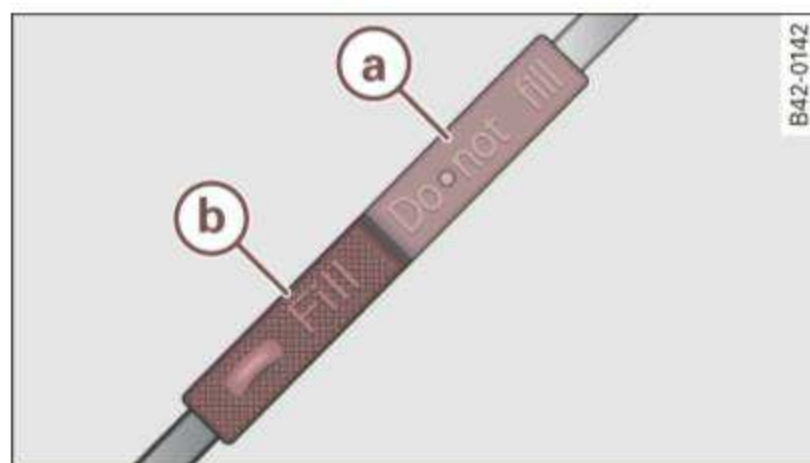

Fig. 120 Markers on oil dipstick

Before you check anything in the engine compartment, **always read and heed all WARNINGS** ⇒ ⚠ in “Working in the engine compartment” on *page 191*.

Determining oil level

- Warm up the engine by driving until the instrument cluster display shows an oil temperature of 210 °F (100 °C) to 230 °F (110 °C) ⇒ *page 195*, fig. 119 ①.
- Park your vehicle so that it is horizontally level.
- Allow the warm engine to run for about two minutes at idle.
- Shut the engine off and wait two minutes.
- Check the oil level on the engine oil dipstick ⇒ fig. 120.

Oil level within range ①

- Do *not* add oil.

Oil level within range ②

- Add 1 quart (1 liter) of oil ⇒ *page 196*. Afterwards, the oil level should be within range ①.

Depending on the way the vehicle is driven and the operating conditions, oil consumption can be up to 1 quart per 1.200 miles (1 liter per 2.000 km). Consumption may be higher within the first 3.000 miles (5.000 km). ■

Adding engine oil 🛢



Fig. 121 Engine compartment: Oil filler cap location

Before you check anything in the engine compartment, **always read and heed all WARNINGS** ⇒ ⚠ in “Working in the engine compartment” on *page 191*.

- Unscrew the cap 🛢 to the engine oil filling hole ⇒ fig. 121.
- Carefully top off with the appropriate oil ⇒ *page 254*.
- Check the oil level again ⇒ *page 195*.
- Top off the oil again, if necessary.
- Screw the cap back on the filling hole and slide the oil dipstick in as far as it will go. ▶

 **WARNING**

- While topping off, the oil must not come in contact with hot engine parts - fire hazard!
- The oil filler cap must be properly secured to prevent oil from being sprayed on the hot engine and exhaust system when the engine is running - fire hazard!
- If your skin has come in contact with the engine oil, you must subsequently cleanse it thoroughly.

 **Note**

- The oil level must not be above range **(a)** - danger of converter or engine damage! Contact an authorized Audi dealer to draw off oil, if necessary.
- Audi does not recommend the use of oil additives. They may damage the engine and adversely affect your New Vehicle Warranty.

 **For the sake of the environment**

- Under no circumstances can the oil come in contact with the sewage network or the soil.
- Observe and follow legal regulations when disposing of empty oil containers. ■

Engine cooling system

Coolant

The coolant provides cooling for the engine. The percentage of the coolant additive determines the freeze protection of the coolant in the winter.

The cooling system has been filled at the factory with a permanent coolant which does not need to be changed. The coolant consists of

a mixture of water and the manufacturer's glycol-based coolant additive G12++ antifreeze with anticorrosion additives (50% for USA models; 60% for Canadian models).

Coolant additive

The percentage of the coolant additive depends on the climatic conditions in which the vehicle is operated. If the percentage of freeze protection in the coolant is too low, the coolant can freeze, leading to a failure of the cooling and heating circuit.

The percentage of coolant additive has already been adjusted at the factory for the vehicle's climatic conditions.

The mix ratio for USA models is 50% water and 50% coolant additive, for Canadian models 40% water and 60% coolant additive. This mixture both assures the necessary frost protection (- 31 °F/- 35 °C for USA models, - 40 °F/- 40 °C for Canada models) and protects metal components in the engine's cooling system from corrosion and scaling. It also raises the boiling point of the coolant.

Summer time

Do not reduce the concentration of the coolant in the summer by adding plain water. **The proportion of coolant additive must be at least 50% but not more than 60%** to maintain antifreeze protection and cooling efficiency.

 **WARNING**

Before you check anything in the engine compartment, always read and heed all WARNINGS ⇒  in "Working in the engine compartment" on page 191.

 **Note**

- Before winter sets in, have the coolant checked to see if the coolant additive in your vehicle is sufficient to meet the climate conditions. This is especially important if you live in a region where the winter is extremely cold. If necessary, increase the proportion of coolant additive to 60%. ▶

- Only G12++, an additive meeting specification “TL-VW 774G” may be used as a coolant additive. Other coolant additives may seriously degrade the corrosion protection. The resulting damage can cause loss of coolant and subsequently lead to serious engine damage.
- The coolant additive G12++ must not be mixed with other coolant additives.
- Do not add any type of radiator leak sealant to your vehicle's engine coolant. Adding radiator repair fluid may adversely affect the function and performance of your cooling system and could result in damage not covered by your New Vehicle Limited Warranty. ■

Checking the engine coolant level

Proceed carefully when checking the coolant.



Fig. 122 Engine compartment: coolant expansion tank

Before you check anything in the engine compartment, **always read and heed all WARNINGS** ⇒ ⚠ in “Working in the engine compartment” on *page 191*.

- Switch the ignition off.
- Place a rag or cloth on the cap of the coolant expansion tank and turn the cap **carefully** to the left (counter-clockwise) ⇒ ⚠.

- Read the coolant level inside the coolant expansion tank ⇒ fig. 122. With a cold engine, it must be above the “min” mark. With a hot engine, it can be a little above the indicated range.

The coolant expansion tank is located on the right side of the engine compartment. Its location can be seen in the engine compartment illustration ⇒ *page 193*.

To obtain an accurate reading, the engine must be switched off.

The expansion tank in your vehicle is equipped with an electric coolant level sensor ⇒ *page 37*. We still recommend you check the coolant level from time to time.

Coolant loss

Coolant loss may indicate a **leak** in the cooling system. In the event of coolant loss, the cooling system should be inspected immediately by your authorized Audi dealer. It is not enough merely to add coolant.

In a **sealed** system, losses can occur only if the boiling point of the coolant is exceeded as a result of overheating.

⚠ WARNING

- **The cooling system is under pressure. Do not open the cap of the coolant expansion tank when the engine is hot. You risk being scalded.**
- **The coolant additive, and therefore the coolant itself, is hazardous to health. Keep the coolant additive in the original container out of the reach of children. It is a poison hazard.**

⚠ Note

Do not add any type of radiator leak sealant to your vehicle's engine coolant. Adding radiator repair fluid may adversely affect the function and performance of your cooling system and could result in damage not covered by your New Vehicle Limited Warranty. ■

Adding coolant

Before you check anything in the engine compartment, **always read and heed all WARNINGS** ⇒  in "Working in the engine compartment" on *page 191*.

- Add coolant.
- Twist the cap on again *tightly*.

Replacement engine coolant must conform to exact specifications ⇒ *page 197*, "Coolant". If the coolant additive G12++ is not available in an emergency, you must not add any other additive. In this case, use only water and restore the correct mix ratio with the specified coolant additive as soon as possible.

Always use *new* engine coolant when refilling.

Do not fill coolant above the "MAX" mark. Excess coolant will be forced out through the pressure relief valve in the cap when the engine becomes hot.

With a major loss of coolant, you should add the coolant only when the engine has *cooled*. In this way you prevent engine damage.

WARNING

- **The cooling system is under pressure and can get very hot. Reduce the risk of scalding from hot coolant by following these steps.**
 - **Turn off the engine and allow it to cool down.**
 - **Protect your face, hands and arms from escaping fluid and steam by covering the cap with a large, thick rag.**
 - **Turn the cap slowly and very carefully in a counter-clockwise direction while applying light, downward pressure on the top of the cap.**

WARNING (continued)

- **To avoid being burned, do not spill antifreeze or coolant on the exhaust system or hot engine parts. Under certain conditions, the ethylene glycol in engine coolant can catch fire.**
- **Antifreeze is poisonous. Always store antifreeze in its original container and well out of the reach of children.**
- **If you drain the coolant, it must be caught and safely stored in a proper container clearly marked "poison".**

Note

- Coolant pollutes the environment and could cause an engine fire. Excess coolant will be forced out through the pressure relief valve in the cap when the engine becomes hot.
- If, in an emergency, only water can be added, the correct ratio between water and antifreeze ⇒ *page 197* must be restored as soon as possible.

For the sake of the environment

Drained coolant should not be reused. Always dispose of used coolant while observing all environmental regulations. ■

Radiator fan

The radiator fan switches on automatically by itself.

The electric radiator fan is controlled by thermostats that switch on and off depending on coolant and engine compartment temperatures.

After you switch the engine off, the radiator fan and the auxiliary fan can continue running for up to 10 minutes - even with the ignition off. It can even switch on again later by itself, if

- the temperature of the engine coolant rises due to the heat build-up from the engine in the engine compartment, or

- the engine compartment heats up because the vehicle is parked in intense sunlight. ■

Brake fluid

Notice

Have the brake fluid changed by an experienced technician.

Brake fluid absorbs moisture from the air. If the water content in the brake fluid is too high, corrosion in the brake system may result after a period of time. The boiling point of the brake fluid will also decrease considerably and decrease braking performance.

Therefore, the brake fluid must be changed **every two years**. Always use new brake fluid which conforms to Federal Motor Vehicle Standard "FMVSS 116 DOT 4".

Brake fluid is replaced according to the Audi maintenance service schedule. Your authorized Audi dealer is equipped with the necessary special tools and replacement parts, has the necessary expertise, and can dispose of the used fluid.

WARNING

- **Brake fluid is poisonous. It must be stored only in the closed original container out of the reach of children!**
- **Brake failure can result from old or inappropriate brake fluid. Observe these precautions:**
 - **Use only brake fluid that meets SAE specification J 1703 and conforms to Federal Motor Vehicle Standard 116. Always check with your authorized Audi dealer to make sure you are using the correct brake fluid. The correct type of brake fluid is also indicated on the brake fluid reservoir.**
 - **The brake fluid must be new. Heavy use of the brakes can cause a vapor lock if the brake fluid is left in the system too**

WARNING (continued)

long. This can seriously affect the efficiency of the brakes as well as your safety. This could result in an accident.

Note

Brake fluid will damage the paint of your vehicle.

For the sake of the environment

Because of the problem of proper disposal of brake fluid as well as the special tools required and the necessary expertise, we recommend that you have the brake fluid changed by your authorized Audi dealer. ■

Battery

General information

All work on the battery requires technical knowledge.

The battery is located behind the cover in the luggage compartment. Remove the cover by pushing it to the left and lifting it out.

The battery is practically maintenance-free and is checked as part of your vehicle's maintenance services.

You are well advised to replace a battery that is older than 5 years.

Disconnecting the battery terminals

Some vehicle functions (power window regulators, for example) are lost if the battery terminals are disconnected. These functions have to be relearned after the battery terminals are connected again. To prevent this, the battery should only be disconnected from the vehicle electrical system when absolutely necessary for repairs. ►

Vehicles not driven for long periods

The battery becomes discharged due to quiescent current consumers even when the vehicle is not used. With extended periods of non-use in the **cold** season, you should have the vehicle battery removed by an authorized Audi dealer or qualified workshop and stored in an frost-free place. This prevents the battery from "freezing" and thereby being destroyed. During the **warmer** seasons it is enough to disconnect the battery negative terminal. Occasionally charge a disconnected battery.

Winter operation

The cold time of year places a special strain on the battery, resulting in reduced starting power. So before the cold weather starts, have the battery inspected and charged as necessary.

Replacing the battery

The new battery **must have** the same capacity, voltage (12 volts), amperage, construction and plug sealing, as the original battery. Specifications are listed on the battery housing. Batteries specially developed by Audi fulfill the maintenance, output, and safety requirements.

We recommend that you use maintenance-free or **cycle-resistant/leak-proof** batteries according to the standards TL 825 06 (from December 1997) and VW 7 50 73 (from August 2001).

Since the vehicle battery is difficult to reach, we recommend having the battery replaced by an authorized Audi dealer or other qualified workshop.

WARNING

- **All work on the battery requires technical knowledge. Please contact an authorized Audi dealer or another authorized facility for questions about the battery - danger of acid burns and explosion hazard!**

WARNING (continued)

- **The battery must not be opened! Do not try to change the battery's liquid level, otherwise detonating gas will escape from the battery - explosion hazard!**





Note

- Battery holder and terminals always have to be secured correctly.
- Before all work on the battery follow the **warnings** below ⇒  in "Working on the battery" on *page 202*.

For the sake of the environment

Because of the problem of proper disposal of a battery, we recommend your authorized Audi dealer change the battery for you. Batteries contain sulfuric acid and lead and must always be disposed of properly in compliance with all environmental regulations. Disposing of vehicle batteries improperly is very dangerous to the environment. Make sure that the removed battery cannot over-balance, otherwise sulfuric acid might escape! ■

Working on the battery

	Always wear eye protection.
	Battery acid contains sulfuric acid. Always wear gloves and eye protection.
	No - sparks - flames - smoking.
	When a battery is charged, it produces hydrogen gas which is explosive and could cause personal injury.
	Always keep the battery well out of reach of children.

The following WARNINGS are very important when working on the battery:

 **WARNING**

Whenever working on the battery or on the electrical system, there is the risk of injury, accident and even fire. Read and heed the following WARNINGS:

- Always wear eye protection. Do not let battery acid or any lead particles get on your skin or clothing. Shield your eyes. Explosive gases can cause blindness or other injury.
- Battery acid contains sulfuric acid. Sulfuric acid can cause blindness and severe burns.
 - Always wear gloves and eye protection. Do not tilt the battery because acid could leak out of the ventilation openings.
 - If you get battery acid in your eyes or on your skin, immediately rinse with cold water for several minutes and get medical attention.

WARNING (continued)

- If you should ingest any battery acid, seek medical attention immediately.
- Do not expose the battery to an open flame, electric sparks or an open light.
- Do not smoke.
- Do not interchange the positive and negative cables.
- When working on the battery, be sure not to short-circuit the terminals with tools or other metal objects. This would cause the battery to heat up very quickly, which could lead to damage or explosion and personal injury.
- When a battery is charged, it produces hydrogen gas which is explosive and could cause personal injury.
- Always keep the battery well out of the reach of children.
- Before work is done on the electrical system, disconnect the negative ground cable.
- Before performing any work on the electrical system, switch off the engine and ignition as well as any electrical equipment. The negative cable on the battery must be disconnected. If you are just going to replace a light bulb, then it is enough to switch off the lights.
- Before disconnecting the battery, switch off the anti-theft alarm system! Otherwise you will set off the alarm.
- When disconnecting the battery, first disconnect the negative cable and then the positive cable.
- Before reconnecting the battery, make sure all electrical consumers are switched off. Reconnect the positive cable first and then the negative cable. Never interchange the cables - this could start a fire!
- Never charge a frozen or a thawed-out battery. It could explode! If a battery has frozen, then it must be replaced. A discharged battery can freeze over at 32 °F (0 °C).

 **WARNING (continued)**

- Make sure the vent hose is always attached to the opening on the side of the battery.
- Never use batteries which are damaged. Danger of explosion! Always replace a damaged battery.

 **WARNING****California Proposition 65 Warning:**



- Battery posts, terminals and related accessories contain lead and lead compounds, chemicals known to the State of California to cause cancer and reproductive problems. Wash hands after handling.

 **Note**

- Do not disconnect the vehicle battery when the ignition is switched on or when the engine is running, otherwise, you will damage electronic components in the electrical system.
- If your vehicle is going to stand for a long period of time without being driven, protect the battery from "freezing", otherwise it will be damaged and will then have to be replaced. ■

Charging the battery

Starting the engine requires a well charged battery.

- Always read and heed all WARNINGS ⇒  in "Working on the battery" on *page 202* and ⇒ .
- Switch off the ignition and all electrical consumers.
- Only when "fast charging": Disconnect the two battery cables (first "negative", then "positive").

- Connect the clamps of the charger to the battery terminals (red = "positive", black or brown = "negative") according to the directions.
- Only now plug the mains lead for the charging equipment into the wall outlet and turn it on .
- When the battery is fully charged: Turn the charging equipment off and remove the mains lead from the wall outlet.
- Now remove the clamps for the charging equipment.
- Reconnect the cables to the battery (first "positive", then "negative").

When charging at *low* voltages (e.g. with a **trickle charger**), the battery cables do not have to be disconnected first. Before charging at *high* voltages, i.e. "**fast charging**", you must disconnect both cables. In either case, follow the instructions from the manufacturer of the charger.

Fastcharging a battery is **dangerous** ⇒  in "Working on the battery" on *page 202*. It requires special charging equipment and the knowledge to go with it. We recommend having your battery fast charged only by a qualified workshop.

A discharged battery can **freeze** at temperatures of only 32°F (0 °C). Allow a frozen battery to thaw completely before attempting to charge it ⇒ . However, we recommend not using a thawed battery again because the battery casing can be cracked due to ice formation and can leak battery acid.

Do not open the battery caps when charging the battery.

 **WARNING**

Charging a battery can be dangerous.

- Never charge a frozen battery. It may explode because of gas trapped in the ice. Allow a frozen battery to thaw out first. ►

⚠ WARNING (continued)

- Do not reuse batteries which were frozen. The battery housing may have cracked and weakened when the battery froze.
- Charge the battery in a well ventilated area. Keep away from open flame or electrical spark. Do not smoke. Hydrogen gas generated by the battery is explosive.
- To reduce the danger of explosion, never connect or disconnect charger cables while the charger is operating.
- Fast charging a battery is dangerous and should only be attempted by a competent technician with the proper equipment.
- Battery acid that may spill during charging should be washed off with a solution of warm water and baking soda to neutralize the acid.

! Note

Never use a fast charger as a booster to start the engine. This will seriously damage sensitive electronic components, such as control units, relays, radio, etc., as well as the battery charger.

i Tips

The vehicle battery must not be charged with a standard small charger that plugs into the cigarette lighter or outlet. ■

Windshield washer container



Fig. 123 Luggage compartment: Windshield washer fluid reservoir

The windshield washer container  is located in the luggage compartment. You can find the reservoir **capacity** in the table in ⇒ *page 254*.

To prevent lime residue from building up on the spray jets, use distilled water when refilling. Always add a glass cleaner solution (with frost protection in the winter).

! Note

- Do not mix engine coolant antifreeze or any other additives to fill up the windshield washer reservoir.
- Do not use glass cleaners containing paint solvent; you risk damaging the paint. ■

Tires and wheels

Tires

General notes

Tires may be the least appreciated and most abused parts of a motor vehicle.

Tires may be the least appreciated and most abused parts of a motor vehicle. Tires are, however, one of the most important parts of a vehicle, particularly considering the comparatively small patch of rubber on each tire that assures that all-important contact between you, your vehicle and the road.

Maintaining the correct tire pressure, making sure that your vehicle and its tires do not have to carry more weight than they can safely handle, avoiding damage from road hazards and regularly inspecting tires for damage including cuts, slashes irregular wear and overall condition are the most important things that you can do to help avoid sudden tire failure including tread separation and blowouts.

Avoiding damage

If you have to drive over a curb or similar obstacle, drive very slowly and as close as possible at a right angle to the curb.

Always keep chemicals including grease, oil, gasoline and brake fluid off the tires.

Inspect the tires regularly for damage (cuts, cracks or blisters, etc.). Remove any foreign bodies embedded in the treads.

Storing tires

Mark tires when you remove them to indicate the direction of rotation. This ensures you to be able to mount them correctly when you reinstall them.

When removed, the wheels or tires should be stored in a cool, dry and preferably dark place.

Store tires in a vertical position if they are not mounted on rims, in a horizontal position if they are mounted on rims.

New tires

New tires have to be broken in ⇒ .

The tread depth of new tires may vary, according to the type and make of tire and the tread pattern.

Hidden damage

Damage to tires and rims is often not readily visible. If you notice unusual vibration or the vehicle pulls to one side, this may indicate that one of the tires has been damaged. The tires must be checked immediately by an authorized Audi dealer or qualified workshop.

Unidirectional tires

A unidirectional tire can be identified by arrows on the sidewall, that point in the direction the tire is designed to rotate. You must follow the specified direction of rotation. This is necessary so that these tires can develop their optimum characteristics regarding grip, road noise, wear and hydroplaning resistance. For more information ⇒ *page 237*.

WARNING

New tires or tires that are old, worn or damaged cannot provide maximum control and braking ability.

- **New tires tend to be slippery and must be broken in. To reduce the risk of losing control, a collision and serious personal injuries, drive with special care for the first 350 miles (560 km).**
- **Driving with worn or damaged tires can lead to loss of control, sudden tire failure, including a blowout and sudden deflation,**

⚠ WARNING (continued)

crashes and serious personal injuries. Have worn or damaged tires replaced immediately.

- Tires age even if they are not being used and can fail suddenly, especially at high speeds. Tires that are more than 6 years old can only be used in an emergency and then with special care and at low speed.

⚠ WARNING (continued)

- Never mount used tires on your vehicle if you are not sure of their “previous history.” Old used tires may have been damaged even though the damage cannot be seen that can lead to sudden tire failure and loss of vehicle control.
- If you notice unusual vibration or if the vehicle pulls to one side when driving, always stop as soon as it is safe to do so and check the wheels and tires for damage. ■

Glossary of tire and loading terminology

Accessory weight

means the combined weight (in excess of those standard items which may be replaced) of R tronic, power steering, power brakes, power windows, power seats, radio, and heater, to the extent that these items are available as factory-installed equipment (whether installed or not).

Aspect ratio

means the ratio of the height to the width of the tire in percent. Numbers of 55 or lower indicate a low sidewall for improved steering response and better overall handling on dry pavement.

Bead

means the part of the tire that is made of steel wires, wrapped or reinforced by ply cords and that is shaped to fit the rim.

Bead separation

means a breakdown of the bond between components in the bead.

Cord

means the strands forming the plies in the tire.

Cold tire inflation pressure

means the tire pressure recommended by the vehicle manufacturer for a tire of a designated size that has not been driven for more than a couple of miles (kilometers) at low speeds in the three hour period before the tire pressure is measured or adjusted.

Curb weight

means the weight of a motor vehicle with standard equipment including the maximum capacity of fuel, oil, and coolant, air conditioning and additional weight of optional equipment.

Extra load tire

means a tire designed to operate at higher loads and at higher inflation pressures than the corresponding standard tire. Extra load tires may be identified as “XL” , “xl”, “EXTRA LOAD”, or “RF” on the sidewall.

Gross Axle Weight Rating (“GAWR”)

means the load-carrying capacity of a single axle system, measured at the tire-ground interfaces.

Gross Vehicle Weight Rating (“GVWR”)

means the maximum total loaded weight of the vehicle. ►

Groove

means the space between two adjacent tread ribs.

Load rating (code)

means the maximum load that a tire is rated to carry for a given inflation pressure. You may not find this information on all tires because it is not required by law.

Maximum load rating

means the load rating for a tire at the maximum permissible inflation pressure for that tire.

Maximum loaded vehicle weight

means the sum of:

- (a) Curb weight
- (b) Accessory weight
- (c) Vehicle capacity weight, and
- (d) Production options weight

Maximum (permissible) inflation pressure

means the maximum cold inflation pressure to which a tire may be inflated. Also called "maximum inflation pressure."

Normal occupant weight

means 150 lbs. (68 kilograms) times the number of occupants seated in the vehicle up to the total seating capacity of your vehicle.

Occupant distribution

means distribution of occupants in a vehicle.

Outer diameter

means the overall diameter of an inflated new tire.

Overall width

means the linear distance between the exteriors of the sidewalls of an inflated tire, including elevations due to labeling, decorations, or protective bands or ribs.

Ply

means a layer of rubber-coated parallel cords.

Production options weight

means the combined weight of those installed regular production options weighing over 5 lbs. (2.3 kg) in excess of those standard items which they replace, not previously considered in curb weight or accessory weight, including heavy duty brakes, ride levelers, roof rack, heavy duty battery, and special trim.

Radial ply tire

means a pneumatic tire in which the ply cords that extend to the beads are laid at substantially 90 degrees to the centerline of the tread.

Recommended inflation pressure

see ⇒ *page 206*, "Cold tire inflation pressure".

Reinforced tire

means a tire designed to operate at higher loads and at higher inflation pressures than the corresponding standard tire. Reinforced tires may be identified as "XL" , "xl" , "EXTRA LOAD" , or "RF" on the sidewall.

Rim

means a metal support for a tire or a tire and tube assembly upon which the tire beads are seated.

Rim diameter

means nominal diameter of the bead seat. If you change your wheel size, you will have to purchase new tires to match the new rim diameter.

Rim size designation

means rim diameter and width.

Rim width

means nominal distance between rim flanges. ►

Sidewall

means that portion of a tire between the tread and bead.

Speed rating (letter code)

means the speed at which a tire is designed to be driven for extended periods of time. The ratings range from 93 mph (150 km/h) to 186 mph (298 km/h) ⇒ *page 217*. You may not find this information on all tires because it is not required by law.

The speed rating letter code, where applicable, is molded on the tire sidewall and indicates the maximum permissible road speeds ⇒  in “Winter tires” on *page 220*.

Tire pressure monitoring system

means a system that detects when one or more of a vehicle's tires are underinflated and illuminates a low tire pressure warning tell-tale.

Tread

means that portion of a tire that comes into contact with the road.

Tread separation

means pulling away of the tread from the tire carcass.

Treadwear indicators (TWI)

means the projections within the principal grooves designed to give a visual indication of the degrees of wear of the tread. See ⇒ *page 215*, “Tread Wear Indicator (TWI)” for more information on measuring tire wear.

Uniform Tire Quality Grading

is a tire information system developed by the United States National Highway Traffic Safety Administration (NHTSA) that is designed to help buyers make relative comparisons among tires. The UTQG is not a safety rating and not a guarantee that a tire will last for a prescribed number of miles or perform in a certain way. It simply gives tire buyers additional information to combine with other considerations, such as price, brand loyalty and dealer recommen-

dations. Under UTQG, tires are graded by the tire manufacturers in three areas: treadwear, traction and temperature resistance. The UTQG information on the tires, molded into the sidewalls.

U.S. DOT Tire Identification Number (TIN)

This is the tire’s “serial number” It begins with the letters “DOT” and indicates that the tire meets all federal standards. The next two numbers or letters indicate the plant where it was manufactured, and the last four numbers represent the week and year of manufacture. For example,

DOT ... 2210 ...

means that the tire was produced in the 22th week of 2010. The other numbers are marketing codes that may or may not be used by the tire manufacturer. This information is used to contact consumers if a tire defect requires a recall.

Vehicle capacity weight

means the rated cargo and luggage load plus 150 lbs. (68 kilograms) times the vehicle's total seating capacity as listed on the label located on the driver's side B-pillar.

Vehicle maximum load on the tire

means that load on an individual tire that is determined by distributing to each axle its share of the maximum loaded vehicle weight and dividing by two.

Vehicle normal load on the tire

means that load on an individual tire that is determined by distributing to each axle its share of the curb weight, accessory weight, and normal occupant weight (distributed in accordance with table below ⇒ *page 209*) and dividing by two. 

Occupant loading and distribution for vehicle normal load for various designated seating capacities

Designated seating capacity, number of occupants	Vehicle normal load, number of occupants	Normally loaded vehicle, occupant distribution
2	2	2 in front

Cold tire inflation pressure

Tire pressure affects the overall handling, performance and safety of a vehicle.



Fig. 124 Tire pressure label: located on driver's side B-pillar

Tire pressure generally refers to the amount of air in a tire that it needs it to do its job and safely carry the combined load of the entire vehicle and its contents. Tire pressure is measured in kilopascals (kPa), the international measuring unit and in pounds per square inch (PSI). Tire pressure is based in part on the vehicle's design and load limit – the greatest amount of weight that the vehicle can carry safely and the tire size. The proper tire pressure is frequently referred to as the “recommended cold tire inflation pressure.” Air in the tires expands when the tire heats up because of internal friction when it flexes in use. The tire pressure is higher when the tire has warmed up than when it is “cold.” It is the inflation pressure in a “cold” tire that counts. Therefore, you should never let air out of a warm tire to match “cold tire inflation pressure” recommendations. The tires would then be underinflated and could fail suddenly.

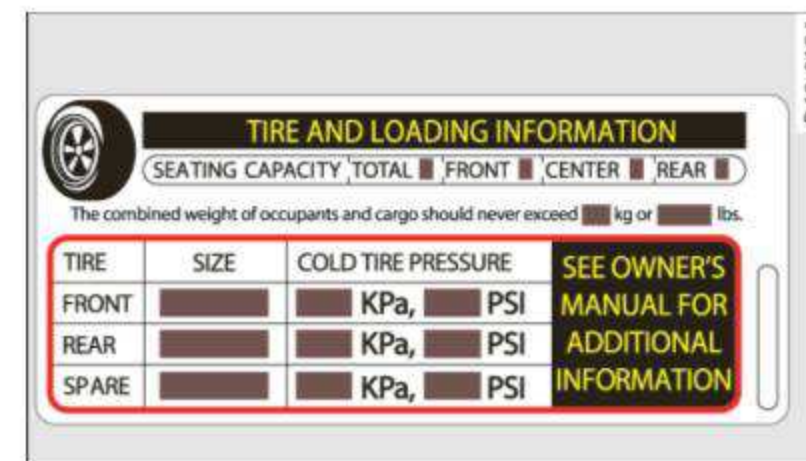



Fig. 125 Tire pressure label

Maintaining proper tire pressure is one of the most important things you can do to help avoid sudden tire failure. Underinflated tires are a major cause of sudden tire failure. Keeping tires at the right pressure is also important for safe and responsive vehicle handling, traction, braking and load carrying. **Tire pressures are particularly important when the vehicle is being driven at higher speeds, and then especially when heavily loaded even within the permissible load-carrying capacities approved for your vehicle.**

The recommended tire pressures for your Audi depend on the kind of tires on your vehicle and the number of passengers and/or amount of luggage you will be transporting.

The tire pressure label located on driver's side B-pillar on your Audi lists the recommended cold tire inflation pressures for the vehicle at its maximum capacity weight and tires that were on your vehicle at the time it was manufactured.

If you wish to improve comfort when operating the vehicle at normal load (up to 2 occupants), you can adjust tire pressures to those specified for normal vehicle load. Before operating the vehicle at maximum load, you must increase the tire pressures to those specified for maximum vehicle load ⇒ .

Bear in mind that the tire pressure monitoring system can only monitor the tire pressures you have stored. The system does not recognize the load condition of your vehicle.

The effectiveness of the tire pressure monitoring system will be impaired if you store normal load pressures but then operate the vehicle at its maximum load ⇒ .

See the illustration ⇒ *page 209*, fig. 124 for the location of the label on driver's side B-pillar (color of the actual label and exact location on the vehicle will vary slightly).

Note that the following table is accurate at the time of going to press and is subject to change. In the event of discrepancies, the tire pressure label on driver's side B-pillar always takes precedence.

The table below lists the recommended cold tire inflation pressures for the Audi model covered by your Owner's Literature at the vehicle's capacity weight and the tire sizes installed on the respective models as original equipment, or as a factory option.

Engine (displacement in liter)	Tire designation	Tire pressure front				Tire pressure rear			
		normal load condition		full load condition		normal load condition		full load condition	
		PSI	kPA	PSI	kPA	PSI	kPA	PSI	kPA
8-cylinder 4.2	235/35 R19 91Y XL	39	270	39	270	---	---	---	---
	295/30 R19 100Y XL	---	---	---	---	36	250	36	250
	305/30 R19 102Y XL	---	---	---	---	36	250	36	250

XL = reinforced

Because technical changes may be made to vehicle equipment during the model year, always compare the tire size designation on the tire pressure label on your vehicle with the tires on your vehicle. Make sure that the tire size information on the vehicle label is the same as the size of the tires on the vehicle. This is especially important if the vehicle belongs to someone else or you bought the vehicle with different rims/tires or you bought the vehicle as a previously owned vehicle.

Remember, your safety and that of your passengers also depends on making sure that load limits are not exceeded. Vehicle load includes everybody and everything in and on the vehicle. These load limits are technically referred to as the vehicle's Gross Vehicle Weight Rating ("GVWR"). The Gross Axle Weight Rating ("GAWR") is

the maximum load that can be applied at each of the vehicle's two axles. The Gross Vehicle Weight Rating and the Gross Axle Weight Rating are listed on the safety compliance sticker label located either on the driver's side B-pillar. The tire pressure label on your Audi lists the maximum combined weight of all of the occupants and luggage or other cargo that the vehicle can carry. For the location of the tire pressure label ⇒ *page 209*, fig. 124.



WARNING

Overloading a vehicle can cause loss of vehicle control, a crash or other accident, serious personal injury, and even death.

 **WARNING (continued)**

- **Carrying more weight than your vehicle was designed to carry will prevent the vehicle from handling properly and increase the risk of a loss of vehicle control.**
- **The brakes on a vehicle that has been overloaded may not be able to stop the vehicle within a safe distance.**
- **Tires on a vehicle that has been overloaded can fail suddenly causing loss of control and a crash.**

 **WARNING**

- **Incorrect tire pressures and/or underinflation can lead to a serious or fatal accident.**
- **Incorrect tire pressures and/or underinflation cause increased tire wear and can affect the handling of the vehicle.**
- **Incorrect tire pressures and/or underinflation can also lead to sudden tire failure, including a blowout and sudden deflation, causing loss of vehicle control. ■**

Checking tire pressure

The correct tire pressure for the tires originally installed on your vehicle is listed on the tire pressure label located on driver's side B-pillar.

The recommended tire pressures are on the tire pressure label and in the table ⇒ *page 209, "Cold tire inflation pressure"*. This means that the pressure must be checked and adjusted when the tire has not been driven for more than a couple of miles (kilometers) at low speeds during the previous three hours. Air in the tires expands when the tire heats up as a result of internal friction as it flexes in use. The tire pressure is higher when the tire has warmed up than when it is "cold."

It is the inflation pressure in a "cold" tire that counts. Therefore, you should never let air out of a warm tire to match "Cold tire inflation pressure" recommendations ⇒ *page 209*. The tires would then be underinflated and could fail suddenly.

The tire pressure label on your Audi lists the recommended cold tire inflation pressures for the new, original equipment tires that were on your vehicle at the time it was manufactured. For the location of the label ⇒ *page 209, fig. 124*.

Most tires lose air naturally over time. They can also lose some air if you drive over a pothole or hit a curb while parking. It is usually not possible to see whether the radial tires used today are underinflated just by looking at them.

Therefore, be sure to check tire pressures at least once a month and always before going on a long trip. Make sure to take the number of people and the amount of luggage into account when adjusting tire pressure for a trip – even one that you would not consider to be "long." See ⇒ *page 213, "Tires and vehicle load limits"* for more important information.

Always use an accurate tire pressure gauge when checking and adjusting inflation pressures. Check all of the tires. If the pressure in any tire is too high when the tire is "cold," let air out of the tire slowly with the edge of the tire gauge and keep checking the pressure until you reach the pressure that is correct for the load (passengers and luggage) and kind of driving you plan to do.

If the pressure in any tire is too low, note the difference between the pressure in the cold tire and the pressure you need and add the air that you need to reach the correct pressure for the vehicle load (passengers and luggage) for the tires on your vehicle as listed on the on your vehicle and in this manual and the kind of driving you plan to do.

Never exceed the maximum inflation pressure listed on the tire sidewall for any reason.

Remember that the vehicle manufacturer, not the tire manufacturer, determines the correct tire pressure for the tires on your vehicle. ►

It is important to check the tire pressure when the tires are cold.

- Read the required tire pressure from the tire pressure label located on driver's side B-pillar.
- Turn the valve stem cap counter-clockwise to remove it from the tire valve.
- Place the air pressure gauge on the valve.
- The tire pressures should only be checked and adjusted when the tires are cold. The slightly raised pressures of warm tires must not be reduced.
- Adjust the tire pressure to the load you are carrying.
- Reinstall the valve stem cap on the valve.

When should I check the tire pressure?

The correct tire pressure is especially important at high speeds. The pressure should therefore be checked at least once a month and always before starting a journey.

When should I adjust the tire pressures?

Adjust the tire pressure to the load you are carrying. After changing a wheel or replacing wheels you have to adjust the tire pressures on all wheels.

WARNING

Incorrect tire pressures and/or underinflation can lead sudden tire failure, loss of control, collision, serious personal injury or even death.

- **When the warning symbol  appears in the instrument cluster, stop and inspect the tires.**
- **Incorrect tire pressure and/or underinflation can cause increased tire wear and can affect the handling of the vehicle and stopping ability.**
- **Incorrect tire pressures and/or underinflation can also lead to sudden tire failure, including a blowout and sudden deflation, causing loss of vehicle control.**

WARNING (continued)

- **The driver is responsible for the correct tire pressures for all tires on the vehicle. The applicable pressure values are located on a sticker on the driver's side B-pillar.**
- **Only when all tires on the vehicle are filled to the correct pressure, the tire pressure monitoring system can work correctly.**
- **The use of incorrect tire pressure values can lead to accidents or other damage. Therefore it is essential that the driver observe the specified tire pressure values for the tires and the correct pressures for the function of the tire pressure monitoring system.**
- **Always inflate tires to the recommended and correct tire pressure before driving off.**
- **Driving with underinflated tires bend more, letting them get too hot resulting in tread separation, sudden tire failure and loss of control.**
- **Excessive speed and/overloading can cause heat build-up, sudden tire failure and loss of control.**
- **If the tire pressure is too low or too high, the tires will wear prematurely and the vehicle will not handle well.**
- **If the tire is not flat and you do not have to change a wheel immediately, drive at reduced speed to the nearest service station to check the tire pressure and add air as required.**

Note

Driving without valve stem caps can cause damage to the tire valves. To prevent this, always make sure that factory installed valve stem caps on all wheels are securely mounted on the valve.

For the sake of the environment

Underinflated tires will also increase the fuel consumption. ■

Tires and vehicle load limits

There are limits to the amount of load or weight that any vehicle and any tire can carry. A vehicle that is overloaded will not handle well and is more difficult to stop. Overloading can not only lead to loss of vehicle control, but can also damage important parts of the vehicle and can lead to sudden tire failure, including a blowout and sudden deflation that can cause the vehicle to crash.

Your safety and that of your passengers also depends on making sure that load limits are not exceeded. Vehicle load includes everybody and everything in and on the vehicle. These load limits are technically referred to as the vehicle's **Gross Vehicle Weight Rating** ("GVWR").

The "GVWR" includes the weight of the basic vehicle, all factory installed accessories, a full tank of fuel, oil, coolant and other fluids plus maximum load. The maximum load includes the number of passengers that the vehicle is intended to carry ("seating capacity") with an assumed weight of 150 lbs (68 kg) for each passenger at a designated seating position and the total weight of any luggage in the vehicle.

The **Gross Axle Weight Rating** ("GAWR") is the maximum load that can be applied at each of the vehicle's two axles.

The Gross Vehicle Weight Rating and the Gross Axle Weight Rating are listed on the safety compliance sticker label located on the driver's side B-pillar. Your Audi has 2 seating positions in the front for total seating capacity of 2. Each seating position has a safety belt ⇒ *page 116, "Safety belts"*.

The fact that there is an upper limit to your vehicle's Gross Vehicle Weight Rating means that the total weight of whatever is being carried in the vehicle is limited. The more passengers in the vehicle or passengers who are heavier than the standard weights assumed mean that less weight can be carried as luggage.

The tire pressure label on your Audi also lists the maximum combined weight of all of the occupants and luggage or other cargo

that the vehicle can carry. For the location of the label ⇒ *page 209, fig. 124.*

WARNING

Overloading a vehicle can cause loss of vehicle control, a crash or other accident, serious personal injury, and even death.

- **Carrying more weight than your vehicle was designed to carry will prevent the vehicle from handling properly and increase the risk of the loss of vehicle control.**
- **The brakes on a vehicle that has been overloaded may not be able to stop the vehicle within a safe distance.**
- **Tires on a vehicle that has been overloaded can fail suddenly, including a blowout and sudden deflation, causing loss of control and a crash. ■**

Determining correct load limit

Use the example below to calculate the total weight of the passengers and luggage or other things that you plan to transport so that you can make sure that your vehicle will not be overloaded. ►

Steps for Determining Correct Load Limit

1. Locate the statement "THE COMBINED WEIGHT OF OCCUPANTS AND CARGO SHOULD NEVER EXCEED XXX KG OR XXX LBS" on your vehicle's placard (tire inflation pressure label) ⇒ *page 209*, fig. 124.
2. Determine the combined weight of the driver and passengers that will be riding in your vehicle.
3. Subtract the combined weight of the driver and passengers from "XXX" kilograms or "XXX" pounds shown on the sticker ⇒ *page 209*, fig. 124.
4. The resulting figure equals the available amount of cargo and luggage load capacity. For example, if the "XXX" amount equals 1400 lbs. and there will be five 150 lbs. passengers in your vehicle, the amount of available cargo and luggage load capacity is 650 lbs. (1400-750 (5 x 150) = 650 lbs.)
5. Determine the combined weight of luggage and cargo being loaded on the vehicle. That weight may not safely exceed the available cargo and luggage load capacity calculated in Step 4.
6. If your vehicle will be towing a trailer, load from your trailer will be transferred to your vehicle. Consult this manual to determine how this reduces the available cargo and luggage load capacity of your vehicle.
 - Check the tire sidewall (⇒ *page 216*, fig. 127) to determine the designated load rating for a specific tire. ■

Tire service life

The service life of tires depends on a lot of different things including proper installation and balancing, correct tire pressure and driving style.

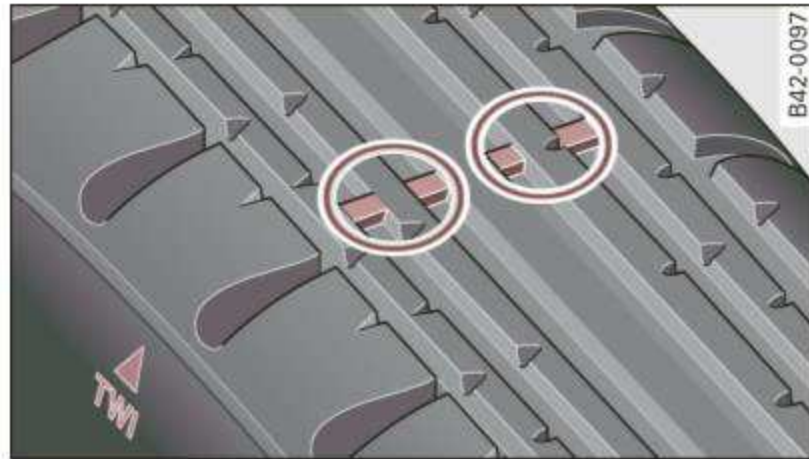

Fig. 126 Tire tread: tread wear indicators (TWI)

Tread Wear Indicator (TWI)

The original tires on your vehicle have 1/16 inch (1.6 mm) high “wear indicators” ⇒ fig. 126 running across the tread. Depending on the make, there will be six to eight of them evenly placed around the tire. Marks on the tire sidewall (for example “TWI” or other symbols) indicate the positions of the tread wear indicators. Worn tires must be replaced. Different figures may apply in other countries ⇒ ⚠.

Tire pressure

Incorrect tire pressure causes premature wear and can cause sudden tire blow-out. For this reason, tire pressure must be checked at least once a month ⇒ page 211.

Driving style

Driving fast around curves, heavy acceleration and hard braking increase tire wear.

Wheel balancing

The wheels on new vehicles are balanced. However, various situations during everyday driving can cause them to become unbal-

anced, resulting in vibrations you can usually feel through the steering wheel.

Unbalanced wheels must be rebalanced to avoid excessive wear on steering, suspension and tires. A wheel must also be rebalanced when a new tire is installed.

Incorrect wheel alignment

Incorrect wheel alignment can cause excessive tire wear, impairing the safety of the vehicle. If tires show excessive wear, have the wheel alignment checked by an authorized Audi dealer or qualified workshop.

All Wheel Drive

Only the wheel/tire sizes specified by the manufacturer may be used on vehicles with all-wheel drive. For details see ⇒ page 169.

⚠ WARNING

Sudden tire failure can lead to loss of control, a crash and serious personal injury!

- **Never drive a vehicle when the tread on any tire is worn down to the wear indicators.**
- **Worn tires are a safety hazard, they do not grip well on wet roads and increase your risk of “hydroplaning” and loss of control.**
- **Always keep chemicals that can cause tire damage, such as grease, oil, gasoline and brake fluid away from tires.**
- **Tires age even if they are not being used and can fail suddenly, especially at high speeds. Tires that are more than 6 years old can only be used in an emergency and then with special care and at lower speeds.**
- **Never mount used tires on your vehicle if you are not sure of their “previous history.” Old used tires may have been damaged even though the damage cannot be seen that can lead to sudden tire failure and loss of vehicle control. ■**

New tires and replacing tires and wheels

New tires and wheels have to be broken in.

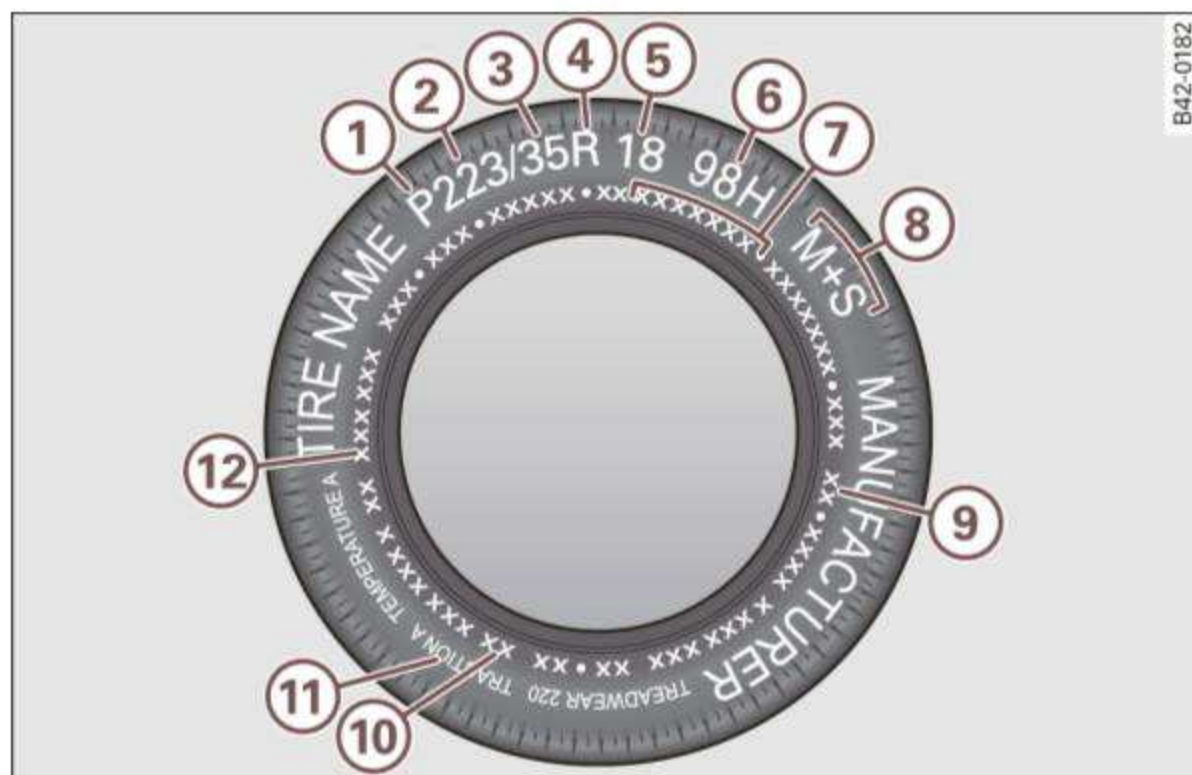

Fig. 127 Tire specification codes on the sidewall of a tire

No.	Description
①	Passenger car tire (where applicable)
②	Nominal width of tire in millimeters
③	Ratio of height to width (aspect ratio)
④	Radial
⑤	Rim diameter code
⑥	Load index and speed rating
⑦	U.S. DOT tire identification number
⑧	Severe snow conditions

⑨	Tire ply composition and materials used
⑩	Maximum load rating
⑪	Treadwear, traction and temperature grades
⑫	Maximum permissible inflation pressure

The tires and rims are essential parts of the vehicle's design. The tires and rims approved by Audi are specially matched to the characteristics of the vehicle and can make a major contribution to good road holding and safe handling when in good condition and properly inflated ⇒ ⚠.

We recommend that all work on tires and wheels be performed by an authorized Audi dealer. They are familiar with recommended procedures and have the necessary special tools and spare parts as well as the proper facilities for disposing of the old tires.

Authorized Audi dealers have the necessary information about technical requirements for installing or changing tires and rims.

Replacing tires and wheels

Tires should be replaced at least in pairs and not individually (for example both front tires or both rear tires together).

Be sure to read and heed the information to the tire pressure monitoring system ⇒ *page 218*.

Always buy replacement radial tires that have the same specifications as the tires approved for your vehicle by Audi. Replacement tires must always have the same load rating specification as the original equipment or approved optional tires listed in the table ⇒ *page 209*.

Audi-approved specification tires are specially matched to your vehicle and its load limits, and can contribute to the important road-holding, driving characteristics, and safety of the vehicle. The table (⇒ *page 209*) lists specifications of the tires approved for the Audi models covered by your Owner's Literature. ▶

The tire pressure label located on driver's side B-pillar (⇒ *page 209*, fig. 125) lists the specifications of the original equipment tires installed on your vehicle at the time it was manufactured.

Federal law requires tire manufacturers to place standardized information on the sidewall of all tires ⇒ *page 216*, fig. 127. This information identifies and describes the fundamental characteristics, the quality grade of the tire and also provides a tire identification number for safety standard certification and in case of a recall.

Tire specifications

Knowledge of tire specifications makes it easier to choose the correct tires. Radial tires have the tire specifications marked on the sidewall, for example:

P235 / 35 R 18 91 Y

This contains the following information:

- P** Indicates the tire is for passenger cars
- 235** Nominal tire width in mm of the tire from sidewall edge to sidewall edge. In general, the larger the number, the wider the tire
- 35** Height/width ratio in percent (aspect ratio)
- R** Tire construction: **R**adial
- 18** Rim diameter code (in inches)
- 91** Load rating code
- Y** Speed rating letter code
- XL** (or "xl", "EXTRA LOAD", or "RF") indicates that the tire is a "Reinforced" or an "Extra Load" tire
- M+S** (or "M/S") Indicates that the tire has some mud and snow capability

The tires could also have the information of direction of rotation ⇒ *page 205*.

Tire manufacturing date

The manufacturing date is also indicated on the tire sidewall (possibly only on the *inner* side of the wheel):

"DOT ... 2210..." means, for example, that the tire was produced in the 22th week of 2010.

Speed rating (letter code)

The speed rating letter code on the wheels indicates the maximum permissible road speeds ⇒ ⚠ in "Winter tires" on *page 220*.

- P** up to 93 mph (150 km/h)
- Q** up to 99 mph (158 km/h)
- R** up to 106 mph (170 km/h)
- S** up to 110 mph (180 km/h)
- T** up to 118 mph (190 km/h)
- U** up to 124 mph (200 km/h)
- H** up to 130 mph (210 km/h)
- V** up to 149 mph (240 km/h)²⁾
- Z** over 149 mph (240 km/h)²⁾
- W** up to 168 mph (270 km/h)²⁾
- Y** up to 186 mph (298 km/h)²⁾

Your vehicle is normally factory equipped with tires, which possess excellent driving characteristics and give your Audi optimum driving comfort ⇒ ⚠.

U.S. DOT Tire Identification Number (TIN) and tire manufacture date

This is the tire's "serial number". It begins with the letters "DOT" and indicates that the tire meets all federal standards. The next two numbers or letters indicate the plant where it was manufactured, and the last four numbers represent the week and year of manufacture. For example, the numbers 2210 mean that the tire was produced in the 22th week of 2010. The other numbers are marketing codes that may or may not be used by the tire manufacturer. This information is used to contact consumers if a tire defect requires a recall. ▶

²⁾ For tires with a maximum speed capability over 149 mph (240 km/h), tire manufacturers sometimes use the letters "ZR."

Tire ply composition and materials used

The number of plies indicates the number of layers of rubber-coated fabric in the tire. In general, the greater the number of plies, the more weight a tire can support. Tire manufacturers also must indicate the materials in the tire, which include steel, nylon, polyester, and others.

Maximum Load Rating

This number indicates the maximum load in kilograms and pounds that can be carried by the tire.

Tire quality grading for treadwear, traction, and temperature resistance

Tread wear, traction and temperature grades ⇒ *page 219*.

Maximum Permissible Inflation Pressure

This number is the greatest amount of air pressure that should ever be put in the tire under normal driving conditions.

Replacing tires or rims on vehicles equipped with tire pressure monitoring system

The wheels on your vehicle are equipped with a sensor which constantly monitors the air pressure inside the tire, and then transmits this information to the tire pressure monitoring system. If you are going to replace the wheel rims on your vehicle, make sure the new rims also have these sensors. The sensors must be compatible with the tire pressure monitoring system on your vehicle.

If you install rims, which do not have the sensors, or have sensors which are not compatible, then the tire pressure monitoring system will not work properly. In this case, the tire pressure monitoring system would not be able to monitor the tire pressure or warn you if it is necessary.

- The battery inside of the tire pressure sensor has a limited service life.

- Always drive with the valve stem caps securely mounted. We recommend using factory installed valve stem caps. Ask your authorized Audi dealer to replace lost valve stem caps.

The installation of replacement tires with steel cord body plies in the tire sidewall may cause malfunction of the tire pressure monitoring system, and is not recommended (cord material information in molded on the tire sidewall).

Always check your tire pressure monitoring system indicator after replacing one or more tires on your vehicle. If the tire pressure monitoring system indicator flashes, or is on, your system is not working properly.

WARNING

- **Using incorrect or unmatched tires and / or wheels or improper tire and wheel combinations can lead to loss of control, collision and serious personal injury.**
- **Always use tires, rims and wheel bolts that meet the specifications of original factory-installed tires or other combinations that have been specifically approved by the vehicle manufacturer.**
- **Tires age even if they are not being used and can fail suddenly, especially at high speeds. Tires that are more than 6 years old can only be used in an emergency and then with special care and at lower speeds.**
- **Never mount used tires on your vehicle if you are not sure of their "previous history." Old used tires may have been damaged even though the damage cannot be seen that can lead to sudden tire failure and loss of vehicle control.**
- **Only the wheel/tire sizes specified by the manufacturer may be used on vehicles with all-wheel drive.**
- **Never drive faster than the maximum speed for which the tires on your vehicle are rated because tires that are driven faster than their rated speed can fail suddenly.**
- **Overloading tires cause heat build-up, sudden tire failure, including a blowout and sudden deflation and loss of control.**

 **WARNING (continued)**

- Temperature grades apply to tires that are properly inflated and not over or underinflated.
- For technical reasons it is not always possible to use wheels from other vehicles – in some cases not even wheels from the same vehicle model.

 **Note**

- For technical reasons, it is not generally possible to use the wheel rims from other vehicles. This can hold true for wheels of the same vehicle type.
- If you should put different wheels and tires on your vehicle (e.g. winter wheels and tires), you must be certain that the wheels and tires are compatible with the tire pressure monitoring system. Otherwise the system will register a malfunction and a fault message will be displayed. For more information, contact your authorized Audi dealer.

 **Note**

- When installing new tires, be careful not to damage the valves or tire pressure monitoring system sensors.
- Never drive without the valve stem cap. The valves could get damaged.
- If the sensors must be replaced, then the valve must also be replaced at the same time.

 **For the sake of the environment**

Dispose of old tires in accordance with the local requirements. ■

Uniform tire quality grading

- Tread wear
- Traction AA A B C
- Temperature A B C

Quality grades can be found where applicable on the tire side wall between tread shoulder and maximum section width ⇒ *page 216*, fig. 127.

For example: Tread wear **200**, Traction **AA**, Temperature **A**.

All passenger car tires must conform to Federal Safety Requirements in addition to these grades.

Tread wear

The *tread wear* grade is a comparative rating based on the wear rate of the tire when tested under controlled conditions on a specified government test course.

For example, a tire graded 150 would wear one and one half (1 1/2) times as well on the government course as a tire graded 100.

The relative performance of tires depends upon the actual conditions of their use, however, and may depart significantly from the norm due to variations in driving habits, service practices and differences in road characteristics and climate.

Traction

The *traction* grades, from highest to lowest, are AA, A, B and C. Those grades represent the tire's ability to stop on wet pavement as measured under controlled conditions on specified government test surfaces of asphalt and concrete. A tire marked C may have poor traction performance ⇒ .

Temperature

The *temperature* grades are A (the highest), B, and C, representing the tire's resistance to the generation of heat and its ability to dissipate heat when tested under controlled conditions on a specified indoor laboratory test wheel. ▶

Sustained high temperature can cause the material of the tire to degenerate and reduce tire life, and excessive temperature can lead to sudden tire failure ⇒ .

The grade C corresponds to a level of performance which all passenger car tires must meet under the Federal Motor Vehicle Safety Standard No. 109. Grades B and A represent higher levels of performance on the laboratory test wheel than the minimum required by law.

WARNING

The traction grade assigned to this tire is based on straight-ahead braking traction tests, and does not include acceleration, cornering, hydroplaning or peak traction characteristics.

WARNING

The temperature grade for this tire is established for a tire that is properly inflated and not overloaded. Excessive speed, underinflation, or excessive loading, either separately or in combination, can cause heat buildup and possible tire failure. ■

Winter tires

Winter tires can improve vehicle handling on snow and ice. At temperatures below 45 °F (7 °C) we recommend changing to winter tires.

In some heavy snow areas, local governments may require true winter or “snow” tires, those with very deeply cut tread. These tires should only be used in pairs and be installed on all four wheels. Make sure you purchase snow tires that are the same size and construction type as the other tires on your vehicle.

If your vehicle is equipped with all-wheel drive*, this will improve traction during winter driving, even with the standard tires. However, we strongly recommend that you always equip all four

wheels on your vehicle with correctly fitted winter tires or all-season tires, when winter road conditions are expected. This also improves the vehicle's braking performance and reduces stopping distances.

Summer tires provide less grip on ice and snow.

Winter tires (snow tires) must always be fitted on all four wheels.

Compatible tire pressure monitoring sensors must be installed on all four winter tires for the tire pressure monitoring system to function properly ⇒ *page 218*.

Ask your authorized Audi dealer or qualified workshop for permitted **winter tire sizes**. Use only radial winter tires.

Winter tires lose their effectiveness when the tread is worn down to a depth of 0.157 inch (4 mm).

Only drive with winter tires under winter conditions. Summer tires handle better when there is no snow or ice on the roads and the temperature is above 45 °F (7 °C).

Please always remember that winter tires may have a lower speed rating than the tires originally installed on your vehicle at the time it was manufactured. Please see ⇒ *page 217*, “Speed rating (letter code)” for a listing of the speed rating letter codes and the maximum speed at which the tires can be driven.

The speed rating letter code (⇒ *page 208*) is on the side wall of the tire ⇒ *page 216*.

WARNING

Winter tires have maximum speed limits that may be lower than your vehicle's maximum speed. Always know the maximum speed before driving off. Never drive faster than the speed permitted for your specific winter tires. This will cause damage to the tires leading to an accident and serious personal injury to you and your passengers.

 **WARNING**

Driving faster than the maximum speed for which the winter tires on your vehicle were designed can cause tire failure including a blowout and sudden deflation, loss of control, crashes and serious personal injuries. Have worn or damaged tires replaced immediately.

- Winter tires have maximum speed rating that may be lower than your vehicle's maximum speed.
- Never drive faster than the speed for which the winter or other tires installed on your vehicle are rated.

 **WARNING**

Always adjust your driving to the road and traffic conditions. Never let the good acceleration of the winter tires and all-wheel drive tempt you into taking extra risks. Always remember:

- When braking, an all-wheel drive vehicle handles in the same way as a front drive vehicle.
- Drive carefully and reduce your speed on icy and slippery roads, even winter tires cannot help under black ice conditions.

 **For the sake of the environment**

Use summer tires when weather conditions permit. They are quieter, do not wear as quickly and reduce fuel consumption. ■

Snow chains

Snow chains may be fitted only to the rear wheels, and only to certain tire sizes. Ask your authorized Audi dealer on which tire sizes snow chains can be used.

The snow chains must have low-profile links and must not be thicker than 0.53 inch (13.5 mm), including the lock.

Remove wheel center covers before putting snow chains on your vehicle ⇒ . For safety reasons cover caps must then be fitted over the wheel bolts. These are available from authorized Audi dealers.

 **WARNING**

Using the wrong snow chains for your vehicle or installing them incorrectly can increase the risk of loss of control leading to serious personal injury.

- Snow chains are available in different sizes. Always make sure to follow the instructions provided by the snow chain manufacturer.
- When driving with snow chains, never drive faster than the speed permitted for your specific snow chains.
- Always observe local regulations.

 **Note**

- Remove snow chains before driving on roads not covered with snow to avoid damaging tires and wearing the snow chains down unnecessarily.
- Snow chains, which come into direct contact with the wheel rim, can scratch or damage it. Therefore, make sure that the snow chains are suitably covered. Check the position of the snow chains after driving a few yards and correct if necessary. Follow the instructions from the snow chain manufacturer when doing so.

 **Tips**

Where snow chains are mandatory on certain roads, this normally also applies to vehicles with All Wheel Drive. ■

Wheel bolts

Wheel bolts must always be tightened to the correct torque.

The design of wheel bolts is matched to the factory installed rims. If different rims are fitted, the correct wheel bolts with the right length and correctly shaped bolt heads must be used. This ensures that wheels are fitted securely and that the brake system functions correctly.

In certain circumstances, you may not use wheel bolts from a different vehicle – even if it is the same model ⇒ *page 227*.

WARNING

Improperly tightened or maintained wheel bolts can become loose causing loss of control, a collision and serious personal injury.

- **Always keep the wheel bolts and the threads in the wheel hubs clean so the wheel bolts can turn easily and be properly tightened.**
- **Never grease or oil the wheel bolts and the threads in the wheel hubs. They can become loose while driving if greased or oiled, even if tightened to the specified torque.**
- **Only use wheel bolts that belong to the rim being installed.**
- **Never use different wheels bolts on your vehicle.**
- **Always maintain the correct tightening torque for the wheel bolts to reduce the risk of a wheel loss. If the tightening torque of the wheel bolts is too low, they can loosen and come out when the vehicle is moving. If the tightening torque is too high, the wheel bolts and threads can be damaged and the wheel can become loose.**

Note

The specified torque for the wheel bolts is 90 ft lb (120 Nm) with a tolerance of ± 7.4 ft lb (± 10 Nm). Torque wheel bolts diagonally. After changing a wheel, the torque must be checked as soon as

possible with a torque wrench – preferably by an authorized Audi dealer or qualified workshop. ■

Low aspect ratio tires

Your Audi is factory-equipped with low aspect ratio tires. These tires have been thoroughly tested and been selected specifically for your model for their superb performance, road feel and handling under a variety of driving conditions. Ask your authorized Audi dealer for more details.

The low aspect ratio of these tires is indicated by a numeral of **55 or less** in the tire's size designation. The numeral represents the ratio of the tire's sidewall height in relation to its tread width expressed in percentage. Conventional tires have a height/width ratio of 60 or more.

The performance of low-aspect-ratio tires is particularly sensitive to improper inflation pressure. It is therefore important that low aspect ratio tires are inflated to the specified pressure and that the inflation pressure is regularly checked and maintained. Tire pressures should be checked at least once a month and always before a long trip ⇒ *page 211*, "Checking tire pressure".

What you can do to avoid tire and rim damage

Low aspect ratio tires can be damaged more easily by impact with potholes, curbs, gullies or ridges on the road, particularly if the tire is underinflated.

In order to minimize the occurrence of impact damage to the tires of your vehicle, we recommend that you observe the following precautions:

- Always maintain recommended inflation pressures. Check your tire pressure every 2.000 miles (3.000 km) and add air if necessary.
- Drive carefully on roads with potholes, deep gullies or ridges. The impact from driving through or over such obstacles can damage your tires. Impact with a curb may also cause damage to your tires. ►

- After any impact, immediately inspect your tires or have them inspected by the nearest authorized Audi dealer. Replace a damaged tire as soon as possible.
- Inspect your tires every 2.000 miles (3.000 km) for damage and wear. Damage is not always easy to see. Damage can lead to loss of air and underinflation, which could eventually cause tire failure. If you believe that a tire may have been damaged, replace the tire as soon as possible.
- These tires may wear more quickly than others.
- Please also remember that, while these tires deliver responsive handling, they may ride less comfortably and make more noise than other choices.

Reduced performance in winter/cold season conditions

All tires are designed for certain purposes. The low aspect ratio, ultra high performance tires originally installed on your vehicle are intended for maximum dry and wet road performance and handling. They are not suitable for cold, snowy or icy weather conditions. If you drive under those circumstances, you should equip your vehicle with winter tires, which offer better traction under those conditions. We suggest you use the recommended snow tires specified for your vehicle, or their equivalent.

Refer to ⇒ *page 220* for more detailed information regarding winter tires. ■

Tire pressure monitoring system

General notes

Each tire, including the spare (if provided), should be checked monthly when cold and inflated to the inflation pressure recommended by the vehicle manufacturer on the vehicle placard or tire inflation pressure label. (If your vehicle has tires of a different size than the size indicated on the vehicle placard or tire inflation pres-

sure label, you should determine the proper tire inflation pressure for those tires.)

As an added safety feature, your vehicle has been equipped with a tire pressure monitoring system (TPMS) that illuminates a low tire pressure telltale when one or more of your tires is significantly under-inflated. Accordingly, when the low tire pressure telltale illuminates, you should stop and check your tires as soon as possible, and inflate them to the proper pressure. Driving on a significantly under-inflated tire causes the tire to overheat and can lead to tire failure. Under-inflation also reduces fuel efficiency and tire tread life, and may affect the vehicle's handling and stopping ability.

Please note that the TPMS is not a substitute for proper tire maintenance, and it is the driver's responsibility to maintain correct tire pressure, even if under-inflation has not reached the level to trigger illumination of the TPMS low tire pressure telltale.

Your vehicle has also been equipped with a TPMS malfunction indicator to indicate when the system is not operating properly. The TPMS malfunction indicator is combined with the low tire pressure telltale. When the system detects a malfunction, the telltale will flash for approximately one minute and then remain continuously illuminated. This sequence will continue upon subsequent vehicle start-ups as long as the malfunction exists.

When the malfunction indicator is illuminated, the system may not be able to detect or signal low tire pressure as intended. TPMS malfunctions may occur for a variety of reasons, including the installation of replacement or alternate tires or wheels on the vehicle that prevent the TPMS from functioning properly. Always check the TPMS malfunction telltale after replacing one or more tires or wheels on your vehicle to ensure that the replacement or alternate tires and wheels allow the TPMS to continue to function properly. ■

Introduction

The tire pressure monitoring system monitors air pressure in all four road wheels while the vehicle is moving.

As soon as the tire pressure monitoring system senses a significant loss of air pressure in one or several tires, text messages and yellow symbols appear in the instrument cluster display to alert the driver. The  warning light in the instrument cluster comes on when the tire is significantly underinflated ⇒ *page 39*.

The warning light  also illuminates in the case of a system malfunction.

Be aware that tire pressure is also dependent on the temperature of the tire. For every 18 °F (10 °C) increase in tire temperature, tire pressure increases by about 1.5 psi (0.1 bar). The tire warms up while the vehicle is moving and tire pressure rises. So you should adjust tire pressure only when they are *cold*, when the temperature of the tires is roughly the same as the ambient air temperature.

In order to keep the tire pressure monitoring system properly calibrated, tire pressure on all four tires should be checked at regular intervals.

The tire pressure is shown on the label located on the driver's side B-pillar (visible when the door is open).

Initializing Tire Pressure Monitoring System

The tire pressures for two sets of wheels/tires (e.g. winter and summer) are stored in your vehicle. You can switch between both sets as many times as you wish without re-initializing the system.

The Tire Pressure Monitoring System must be re-initialized by your authorized Audi dealer if a new set of tires is used or the wheel electronics were replaced.

WARNING

- When the tire pressure monitoring system warning light is lit, one or more of your tires is significantly under-inflated. You should

WARNING (continued)

stop and check your tires as soon as possible, and inflate them to the proper pressure as indicated on the vehicle's tire pressure label ⇒ *page 209*. Driving on a significantly under-inflated tire causes the tire to overheat and can lead to tire failure. Under-inflation also is likely to impair the vehicle's handling and stopping ability.



For the sake of the environment

Driving with under-inflated tires reduces fuel efficiency and tire tread life.



Tips

- Each tire should be checked monthly when the temperature of the tires is about the same as ambient air temperature and set to the recommended inflation pressure as specified on the tire pressure label ⇒ *page 209*.
- The tire pressure monitoring system helps the driver to keep an eye on tire pressures. But the driver still has the responsibility for maintaining the correct tire pressure.
- Tire pressure must only be adjusted when the temperature of the tires is about the same as ambient air temperature.
- When tires are replaced, the sensors and valves should not be exchanged. The valve core, nut, valve sealing and seal washer (replacement kit) needs to be replaced. If necessary, the valve and the wheel electronics have to be replaced.
- If you should put different wheels and tires on your vehicle (e.g. winter wheels and tires), you must be certain that the wheels and tires are compatible with the tire pressure monitoring system. Otherwise the system will register a malfunction and a fault message will be displayed. For more information, contact your authorized Audi dealer. ■

Consumer Information

Warranty coverages

Your Audi is covered by the following warranties:

- *New Vehicle Limited Warranty*
- *Limited Warranty Against Corrosion Perforation*
- *Emissions Control System Warranty*
- *Emissions Performance Warranty*
- *California Emissions Control Warranty (USA vehicles only)*
- *California Emissions Performance Warranty (USA vehicles only)*

Detailed information regarding your warranties can be found in your **Warranty & Maintenance booklet**. ■

Reporting safety defects

Operating your vehicle outside the U.S.A. or Canada

Government regulations in the United States and Canada require that automobiles meet specific emission regulations and safety standards. Therefore, vehicles built for the U.S.A. and Canada differ from vehicles sold in other countries.

If you plan to take your vehicle outside the continental limits of the United States or Canada, there is the possibility that

- unleaded fuels for vehicles with catalytic converter may not be available;
- fuel may have a considerably lower octane rating. Improper fuel may cause engine damage;

- service may be inadequate due to lack of proper service facilities, tools or testing equipment;
- replacement parts may not be readily available.
- Navigation systems for vehicles built for the U.S.A. and Canada will not necessarily work in Europe, and may not work in other countries outside of North America.



Note

Audi cannot be responsible for mechanical damage that could result from inadequate fuel, service or parts availability. ■

Audi Service Repair Manuals and Literature

Audi Official Factory Service Manuals are published as soon as possible after model introduction. Service manuals are available from :

Audi Technical Literature Ordering Center

Call toll-free:

Tel.: 1 (800) 544-8021

(from 8:00 AM to 8:00 PM, EST, Monday through Friday)

or access their website **www.audi.ddsld.com** on the Internet to order repair manuals and other Audi literature. ■

Maintenance

General

Your vehicle has been designed to help keep maintenance requirements to a minimum. However, a certain amount of regular maintenance is still necessary to assure your vehicle's safety, economy and reliability. For detailed vehicle maintenance consult your Warranty & Maintenance booklet.

Under difficult operating conditions, for example at extremely low outside temperatures, in very dusty regions, etc., some service work should be performed between the intervals specified. This applies particularly to:

- oil changes, and
- cleaning or replacing the air filter.



For the sake of the environment

By regularly maintaining your vehicle, you help make sure that emission standards are maintained, thus minimizing adverse effects on the environment. ■

Important considerations for you and your vehicle

The increasing use of electronics, sophisticated fuel injection and emission control systems, and the generally increasing technical complexity of today's automobiles, have steadily reduced the scope of maintenance and repairs which can be carried out by vehicle owners. **Also, safety and environmental** concerns place very strict limits on the nature of repairs and adjustments to engine and transmission parts which an owner can perform.

Maintenance, adjustments and repairs usually require special tools, testing devices and other equipment available to specially trained

workshop personnel in order to assure proper performance, reliability and safety of the vehicle and its many systems.



Improper maintenance, adjustments and repairs can impair the operation and reliability of your vehicle and even void your vehicle warranty. Therefore, proof of servicing in accordance with the maintenance schedule may be a condition for upholding a possible warranty claim made within the warranty period.

Above all, operational safety can be adversely affected, creating unnecessary risks for you and your passengers.

If in doubt about any servicing, have it done by your authorized Audi dealer or any other properly equipped and qualified workshop. We strongly urge you to give your authorized Audi dealer the opportunity to perform all scheduled maintenance and necessary repairs. Your dealer has the facilities, original parts and trained specialists to keep your vehicle running properly.

Performing limited maintenance yourself

The following pages describe a limited number of procedures which can be performed on your vehicle with ordinary tools, should the need arise and trained personnel be unavailable. Before performing any of these procedures, always thoroughly read all of the applicable text and carefully follow the instructions given. Always rigorously observe the **WARNINGS** provided.

Before you check anything in the engine compartment, always read and heed all WARNINGS ⇒  and ⇒  in "Working in the engine compartment" on *page 191*.



WARNING

- **Serious personal injury may occur as a result of improperly performed maintenance, adjustments or repairs.**
- **Always be extremely careful when working on the vehicle. Always follow commonly accepted safety practices and general common sense. Never risk personal injury.**

⚠ WARNING (continued)

- Do not attempt any of the maintenance, checks or repairs described on the following pages if you are not fully familiar with these or other procedures with respect to the vehicle, or are uncertain how to proceed.
- Do not do any work without the proper tools and equipment. Have the necessary work done by your authorized Audi dealer or another properly equipped and qualified workshop.
- Always remove the ignition key before anyone gets under the vehicle.
- Always support your vehicle with safety stands if it is necessary to work underneath the vehicle. The jack supplied with the vehicle is not adequate for this purpose and could collapse causing serious personal injury.
- If you must work underneath the vehicle with the wheels on the ground, always make sure the vehicle is on level ground, that the wheels are always securely blocked and that the engine cannot be started.
- Always make sure the transmission selector lever is in "N" (Neutral) (R tronic) or Neutral (manual transmission) and the hand brake is firmly applied.

**For the sake of the environment**

- Changing the engine settings will adversely affect emission levels. This is detrimental to the environment and increases fuel consumption.
- Always observe environmental regulations when disposing of old engine oil, used brake fluid, dirty engine coolant, spent batteries or worn out tires.
- Undeployed airbag modules and pretensioners might be classified as Perchlorate Material -special handling may apply, see www.dtsc.ca.gov/hazardouswaste/perchlorate. When the vehicle or parts of the restraint system including airbag modules safety belts

with pretensioners are scrapped, all applicable laws and regulations must be observed. Your authorized Audi dealer is familiar with these requirements and we recommend that you have your dealer perform this service for you. ■

Additional accessories, modifications and parts replacement**Additional accessories and parts replacement**

Always consult an authorized Audi dealer before purchasing accessories.

Your vehicle incorporates the latest safety design features ensuring a high standard of active and passive safety.

This safety could be compromised by non-approved changes to the vehicle. For this reason, if parts have to be replaced, please observe the following points when installing additional accessories:

Approved Audi accessories and genuine Audi parts are available from authorized Audi dealers.

These dealers also have the necessary facilities, tools and trained specialists to install the parts and accessories properly.

⚠ WARNING

Using the wrong spare parts or using non-approved accessories can cause serious personal injury.

- Use only accessories expressly approved by Audi and genuine Audi spare parts
- These parts and accessories have been specially designed to be used on your vehicle.
- Never install accessories such as telephone cradles or beverage holders on airbag covers or within the airbag deploy-

⚠ WARNING (continued)

ment zones. Doing so will increase the risk of injury if airbags are triggered in an accident!

- Before you check anything in the engine compartment, always read and heed all WARNINGS ⇒ *page 191*.

! Note

- If items other than genuine Audi spare parts, add-on equipment and accessory items are used or if repair work is not performed according to specified methods, this can result in severe damage to your vehicle's engine and body (such as corrosion) and adversely affect your vehicle's warranty.
- The innovative aluminium concept of your Audi means that all servicing, repairs or other work on the vehicle body must be carried out exclusively by an Audi workshop.
- If emergency repairs must be performed elsewhere, have the vehicle examined by an authorized Audi dealership as soon as possible.
- The manufacturer cannot be held liable for damage which occurs due to failure to comply with these stipulations. ■

Technical Modifications

Our guidelines must be complied with when technical modifications are made.

Always consult an authorized Audi dealer **before** starting work on any modifications.

This will help ensure that vehicle function, performance and safety are not impaired ⇒ ⚠.

Attempting to work on electronic components and the software used with them can cause malfunctions. Because of the way electronic components are interconnected with each other, such

malfunctions can also have an adverse affect on other systems that are not directly involved. This means that you risk both a substantial reduction in the operational safety of your vehicle and an increased wear of vehicle parts ⇒ ⚠.

Authorized Audi dealers will perform this work in a professional and competent manner or, in special cases, refer you to a professional company that specializes in such modifications.

⚠ WARNING

Improper repairs and modifications can change the way vehicle systems work and cause serious personal injury.

! Note

If emergency repairs must be performed elsewhere, have the vehicle examined by an authorized Audi dealership as soon as possible. ■

Declaration of Compliance, Telecommunication or Electronic Systems

The following devices comply with part 15 of the FCC rules (USA models) and RSS-210 of Industry Canada (Canada models):

- Cell phone package
- Electronic immobilizer
- HomeLink® universal remote control
- Remote control key
- Tire pressure monitoring system

Operation is subject to the following conditions:

- these devices may not cause harmful interference, and

- these devices must accept any interference received, including interference that may cause undesired operation.

 **Tips**

The manufacturer is not responsible for ANY RADIO OR TV interference caused by unauthorized modifications to this equipment. Changes or modifications to this equipment not expressly approved by the party responsible for compliance could void the user's authority to operate the equipment. ■





What do I do now?

Applies to vehicles: with trunk escape handle

Trunk escape handle

In case of an emergency, the front lid can be opened from the inside using the trunk escape handle.

- To open the front lid pull the handle.

The trunk escape handle inside the luggage compartment is made of fluorescent material to glow in the dark.

WARNING

The trunk escape handle is to be used only in an emergency. ■

Breakdown kit

The breakdown kit consists of vehicle tool kit and tire mobility system.

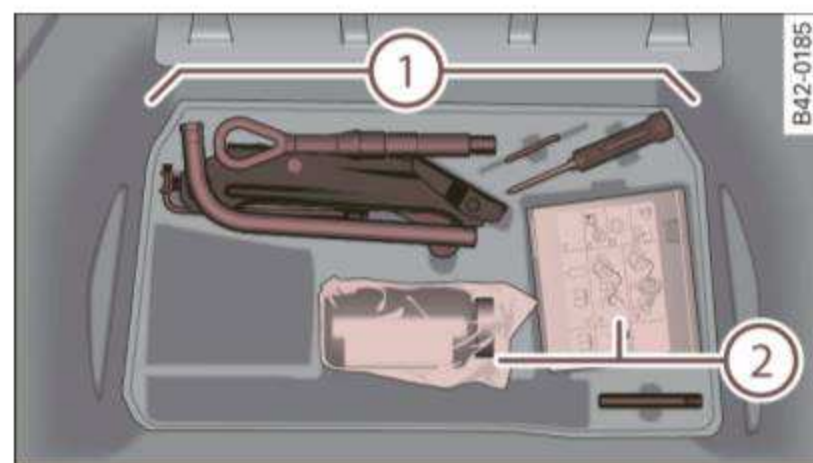

Fig. 128 Breakdown kit in luggage compartment

- ① Vehicle tool kit
- ② Tire mobility system ⇒ page 233

The breakdown kit is located in the luggage compartment under the cargo floor.

The tool kit consists of the following items:

- Hook for removing full wheel cover* or hub cap
- Lug wrench
- Alignment pin for changing wheels
- Screwdriver with reversible blade
- Towing eye
- Jack*

Before returning the jack* to its place, retract the jack arm fully.

Note: some of the items listed above are provided on certain models only or are optional extras.

WARNING

- **Never use the hexagonal socket in the handle of the screwdriver to loosen or tighten the wheel bolts.**
- **The factory-supplied jack* is intended only for your vehicle model. Under no circumstances use it to lift heavy vehicles or other loads; you risk injuring yourself.**
- **Never start or run the engine while the vehicle is supported by the jack.**
- **If you must work under the vehicle, always use safety stands specifically designed for this purpose.**
- **Using a bumper jack to raise the vehicle will damage the bumper system. The jack may slip, causing injury. ■**

Tire repair

General and safety pointers

Tire repair is intended only for temporary, short-term use.



Fig. 129 Tire damage for which the Tire Mobility System is not suited

Your vehicle is equipped with a tire repair kit, the **Tire Mobility System (TMS)**.

In the event of a tire failure, the **TMS** is in the luggage compartment under the floor. It consists of the tire sealant and an electric air pump.

Using **TMS**, tire damage caused by foreign bodies up to about **0.16 inch (4 mm)** in diameter can be sealed reliably.

The foreign object must stay in the tire.

The tire sealant must not be used:

- for cuts or punctures in the tire which are larger than 0.16 inch (4 mm) ⇒ fig. 129 ①
- for damage to the rim ②
- if you have been driving with very low tire pressures or tires with no air ③

Using the **TMS** is described in the section ⇒ page 234, "Preliminary steps".

TMS can be used at temperatures down to $-4\text{ }^{\circ}\text{F}$ ($-20\text{ }^{\circ}\text{C}$).

⚠ WARNING

Take the following precautions after repairing the tire:

- Do not drive faster than 50 mph (80 km/h)!
- Avoid full-throttle acceleration, heavy braking and fast cornering.
- The vehicle's road behavior can be affected.
- Tires sealed with TMS are intended only for temporary, short-term use. Damaged tires must be replaced. Drive carefully to the next professional repair facility.
- After using the tire sealant the tire pressure monitoring system may no longer work properly. Drive carefully to the next professional repair facility.
- TMS must NOT be used,
 - for cuts or punctures in the tire which are larger than 0.16 inch (4 mm)
 - for damage to the rim
 - if you have been driving with very low tire pressures or tires with no air
- Seek professional assistance if it is not possible to repair the tire with the tire sealant.
- The tire sealant must not come into contact with skin, eyes or clothing.
- If you get any tire sealant in your eyes or come into contact with it, rinse the affected area thoroughly with clean water. Find a physician immediately!
- Change any clothing contaminated with tire sealant immediately.
- Do not inhale the vapor!
- If you have swallowed tire sealant, rinse your mouth thoroughly right away and drink plenty of water.
 - Do not induce vomiting! Find a physician immediately!
- If you have allergic reactions, find a physician immediately.

 WARNING (continued)

- Keep the tire sealant away from children.

 Note

Do not use commercially available tire sealants. The electrical components of the tire pressure monitoring system will no longer work properly.

 For the sake of the environment

Used sealant bottles can be dropped off at a recycling facility.

 Tips

- If sealant has run out, allow it to dry. Then you can peel it off.
- Have the tire sealant replaced every 4 years at a dealership. ■

Preliminary steps

Some preliminary steps are necessary for tire repair.

- If you have a flat tire, park the vehicle as far as possible from moving traffic.
- Apply the **parking brake** firmly.
- Engage a gear.
- Check whether a repair using the Tire Mobility System is possible ⇒ *page 233*.
- Have all passengers **leave** the vehicle and stay away from the danger zone ⇒ .

- Take the **sealant bottle** and the **electric air pump** from the luggage compartment under the floor ⇒ *page 232*, fig. 128.
- Remove the “max. 50 mph” (80 km/h) sticker from the sealant bottle and affix it to the instrument cluster in the driver's view.

 WARNING

- Turn the hazard flashers on if you have a flat tire in moving traffic. In this way you protect yourself and other road users.
- Make sure that all passengers are in a safe place, out of the danger zone (for example, behind a guard rail).

 Note

Particular care is necessary if you are making a tire repair on a steep incline.

 Tips

Obey all laws. ■

Making a tire repair

Tire repair consists of the following sections.

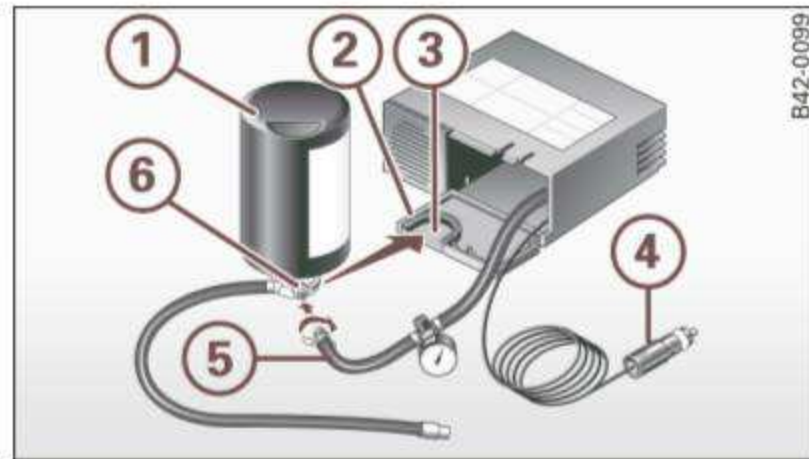

Fig. 130 Parts of the Tire Mobility System

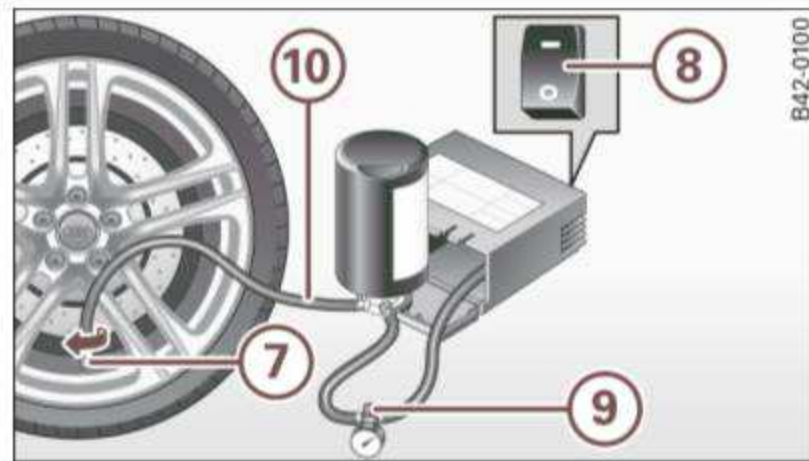

Fig. 131 Connector for the Tire Mobility System

Assembling Tire Mobility System

- Open the lid (2) of the electric air pump ⇒ page 235, fig. 130.
- Pull the plug (4) and the pressure hose (5) with the gauge out of the housing.
- Screw the pressure hose (5) of the electric air pump onto the flange (6) of the sealant bottle (1).
- Push the sealant bottle with the flange down into the recess (3) on the lid of the electric air pump.

- Remove the dust cap from the valve of the defective tire.
- Screw the hose (10) onto the valve (7) ⇒ fig. 131.
- Insert the plug (4) ⇒ page 235, fig. 130 into the socket for the cigarette lighter.

Inflating tire

- Move the switch (8) ⇒ fig. 131 on the electric air pump³⁾ to position I. After 5 minutes, tire pressure must have reached at least 1.8 bar.
- Switch the electric air pump off - switch in position 0. If the required tire pressure of at least 1.8 bar has not been reached, follow the instructions in the section *Re-inflating tire*.

Re-inflating tire

- Remove the hose from the valve and pull the plug out of the socket.
- Drive the vehicle slowly 10 meters backward or forward. This helps to distribute the sealant better.
- Remove the empty inflation bottle and screw the hose (5) (5) ⇒ page 235, fig. 130 from the electric pump directly onto the valve.
- Insert the plug (4) into the socket for the cigarette lighter.
- Move the switch (8) ⇒ fig. 131 on the electric air pump³⁾ to position I. After 5 minutes, tire pressure must have reached at least 1.8 bar. ▶

³⁾ The electric air pump should never run for longer than 8 minutes.

- Switch the electric air pump off - switch in position **0**. If the required tire pressure of at least 1.8 bar has not been reached, it is not possible to make a repair with the tire sealant. Seek professional assistance.

Disassembling Tire Mobility System

- Remove the hose from the valve and pull the plug out of the socket.
- Screw the dust cap onto the valve.
- Place the empty sealant bottle back in the original packaging and clip it in place under the floor so that no tire sealant can run out into the vehicle.
- Start driving right away so that the sealant is distributed in the tire.

WARNING

- Follow the manufacturer's safety instructions on the decal for the air pump and the sealant bottle.
- If a tire pressure of 1.8 bar cannot be achieved after pumping for 5 minutes, the tire is too severely damaged. Do not continue to drive.
- Seek professional assistance if it is not possible to repair the tire with the tire sealant.

Tips

- Do not operate the electric air pump for more than 8 minutes without stopping, otherwise it can overheat. When the air pump has cooled down, you can continue to use it.
- If sealant has escaped, allow it to dry, then you can peel it off. ■

Final check

After driving for a short distance, tire pressure must be checked.

- After driving for about 10 minutes, stop and check the tire pressure.
- If tire pressure is still at least 1.3 bar, inflate the tire to specified pressure (see driver's side B-pillar), drive to the next repair shop and have the tire and the sealant bottle replaced.
- If tire pressure is less than 1.3 bar, the tire is too severely damaged. Do not continue to drive. Seek professional assistance.

WARNING

If tire pressure is less than 1.3 bar after driving for 10 minutes, the tire is too severely damaged. Do not continue to drive. Seek professional assistance.

Tips

After a tire repair, have the sealant bottle replaced at a dealership. This restores full functionality to the Tire Mobility System. ■

What should I be aware of when changing a tire?

Tires with unidirectional tread design

Tires with unidirectional tread design must be mounted with their tread pattern pointed the right direction.

A unidirectional tire can be identified by **arrows on the sidewall**, which point in the direction of the rotation. You must follow the specified direction of rotation. This is necessary in order for these tires to develop their optimum characteristics regarding grip, road noise, wear, and hydroplaning. ■

Applies to vehicles: with anti-theft wheel bolts

Anti-theft wheel bolts

A special adapter is needed to turn the anti-theft wheel bolts.

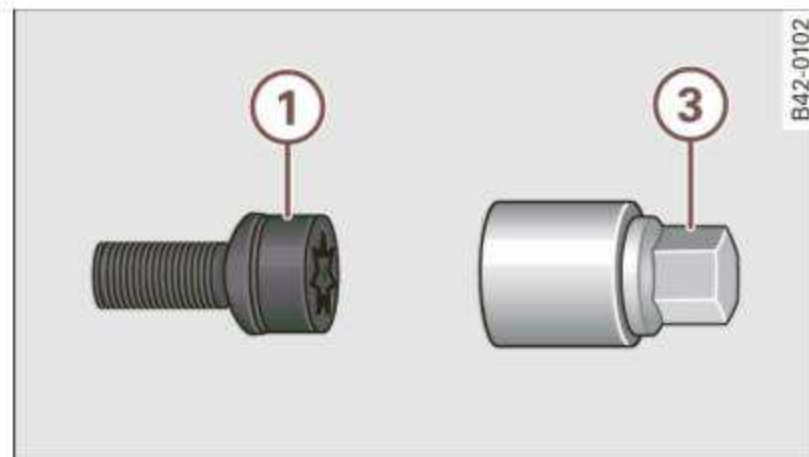

Fig. 132 Anti-theft wheel bolts with adapter

- Install the adapter (2) as far as it will go onto the anti-theft wheel bolt (1).
- Push the wheel wrench over the adapter (2) as far as it will go.

- Loosen or tighten the wheel bolt ⇒ page 239.

We recommend always keeping the wheel bolt adapter with you in the vehicle. It should be stored in the vehicle tool kit.

There is a **code number** for the wheel bolt locking device, stamped on the face of the adapter. You can use this number to obtain a replacement adapter at an authorized Audi dealership, if necessary.



Tips

Write down the wheel bolt locking device code number and store it in a safe place, away from the vehicle. ■

Applies to vehicles: with jack

Raising the vehicle

The vehicle must be lifted with the jack first before the wheel can be removed.

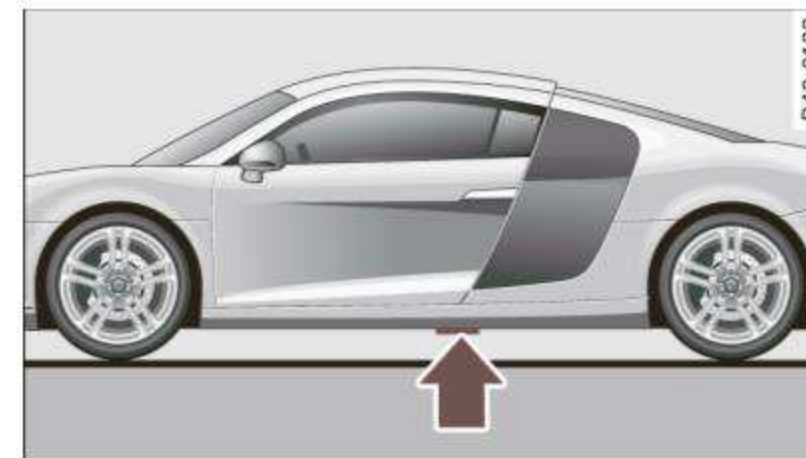

Fig. 133 Wheel change: mounting points for the lifting jack



Fig. 134 Close-up:
proper positioning of
lifting jack

- Find the **mounting point** on the rocker panel which is closest to the flat tire ⇒ fig. 133.
- Crank the jack up until it can be positioned under the lift point on the vehicle.
- Align the jack so the claw ⇒ fig. 134 (A) grips the mounting point on the rocker panel and the flexible base plate (B) is flat on the ground.
- Continue to crank the jack until the wheel is lifted just clear of the ground.

Recesses at the front and rear of the underbody rib mark the proper mounting locations for the jack ⇒ page 237, fig. 133. There is *only one* designated jack mounting point for each wheel. *Do not* apply the jack anywhere else ⇒ ⚠.

An **unstable surface** under the jack can cause the vehicle to slip off the jack. Always provide a firm base for the jack on the ground. If necessary place a sturdy board or similar support under the jack. On **hard, slippery surfaces** (such as tiles) use a rubber mat or similar to prevent the jack from slipping ⇒ ⚠.

⚠ WARNING

- You or your passengers could be injured while changing a wheel if you do not follow safety precautions:
 - Mounting the jack under the vehicle at any other place than indicated above may damage the vehicle or may result in personal injuries.
 - A soft or unstable surface under the jack may cause the vehicle to slip off the jack. Always provide a firm base for the jack on the ground. If necessary, use a sturdy board under the jack.
 - On hard, slippery surface (such as tiles) use a rubber mat or similar to prevent the jack from slipping.
- To help prevent injury to yourself and your passengers:
 - Do not raise the vehicle until you are sure the jack is securely engaged.
 - Passengers must not remain in the vehicle when it is jacked up.
 - Make sure that passengers wait in a safe place away from the vehicle and well away from the roadway and traffic.
 - Make sure jack position is correct, adjust as necessary and then continue to raise the jack.

⚠ Note

A floor jack or the pads on the hoist arms must **not** be positioned at the points shown ⇒ page 237, fig. 133 -arrows-. ■

Removing the wheel

Follow these instructions step-by-step for changing the wheel.

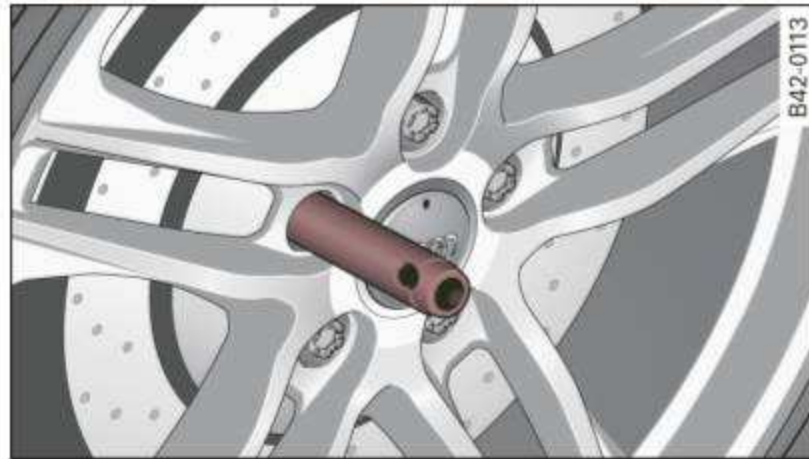

Fig. 135 Wheel change: alignment pin inside the top hole

After you have loosened all wheel bolts and raised the vehicle off the ground, perform the following steps to remove and replace the wheel:

Removing the wheel

- Use the **hexagonal socket in the screwdriver handle** to completely turn out the topmost wheel bolt and set it aside on a *clean* surface.
- Screw the threaded end of the **alignment pin** from the tool kit hand-tight into the now vacant bolt hole ⇒ fig. 135.
- Then completely unscrew the other wheel bolts as described above.
- Take off the wheel ⇒ ⚠ leaving the alignment pin in the bolt hole.

Putting on the wheel

- Lift the spare wheel and carefully slide it over the alignment pin to guide it in place ⇒ ⚠.
- Use the hexagonal socket in the screwdriver handle to screw in and tighten all wheel bolts *slightly*.
- Unscrew the alignment pin and insert and tighten the remaining wheel bolt slightly like the rest.
- Turn the jack handle counter-clockwise to lower the vehicle until the jack is fully released.

The wheel bolts must be clean and turn easily. Check the contact surfaces of wheel and hub. Remove contaminants on these surfaces before installing the wheel.

The hexagonal socket in the screwdriver handle makes it easier to handle the wheel bolts. The reversible blade should be removed.

When mounting **unidirectional** tires, observe the direction of rotation ⇒ page 237.

⚠ Note

When removing/putting on the wheel, the rim can strike the brake disc and damage it. You should therefore proceed with caution, and have a second person assist you.

i Tips

Never use the hexagonal socket in the handle of the screwdriver to loosen or tighten the wheel bolts. ■

Tightening wheel bolts

- Fit the **wheel bolt wrench** over the wheel bolt and push it down as far as it will go⁴⁾. ▶

- Close your grip around the *end* of the wrench handle for maximum torque and turn each wheel bolt **clockwise** until it sits tight.

Have the **tightening torque** of the wheel bolts checked as soon as possible with a torque wrench. It should be 120 Nm.

Check the **tire pressure** as soon as possible.

Return the vehicle tool kit to its proper place.

WARNING

Loosening the wheel bolts is prohibited; danger of an accident!

Tips

- Never try and use the hexagonal socket in the handle of the screwdriver to loosen or tighten the wheel bolts.
- If you have determined that wheel bolts are corroded and difficult to turn, the bolts must be replaced before checking the torque.
- Until the tightening torque is checked, drive at reduced speeds as a precaution. ■

Notes on wheel change

Please read the information ⇒ *page 216*, “New tires and replacing tires and wheels”, if you are going to use a spare tire which is different from the tires on your vehicle.

After you change a tire:

- Check the tire pressure on the spare immediately after mounting.

⁴⁾ You need the appropriate adapter to tighten the anti-theft wheel bolts ⇒ *page 237*.

- Have the wheel bolt tightening torque checked with a torque wrench as soon as possible by your authorized Audi dealer or a qualified service station.
- With steel and alloy wheel rims, the wheel bolts are correctly tightened at a torque of 90 ft lb (120 Nm).
- If you notice while changing a tire that the wheel bolts are corroded and difficult to turn, then they should be replaced before you check the tightening torque.
- Replace the flat tire with a new one and have it installed on your vehicle as soon as possible. Remount the wheel cover.

Until then, drive with extra care and at reduced speeds.

WARNING

- If you are going to equip your vehicle with tires or rims which differ from those which were factory installed, then be sure to read the information ⇒ *page 216*, “New tires and replacing tires and wheels”.
- Always store the tools securely in luggage compartment. Otherwise, in an accident or sudden maneuver they could fly forward, causing injury to passengers in the vehicle.

Note

Do not use commercially available tire sealants. Otherwise, the electrical components of the tire pressure monitoring system* will no longer work properly and the sensor for the tire pressure monitoring system will have to be replaced by a qualified workshop. ■

Jump-starting

General

If necessary, the engine can be started by connecting it to the battery of another vehicle.

If the engine should fail to start because of a discharged or weak battery, the battery can be connected to the battery of *another* vehicle, using a **pair of jumper cables** to start the engine.

Both batteries must be rated at 12 volts. The **capacity** (Ah) of the booster battery must not be substantially less than the capacity of the discharged battery.

Jumper cables

Use *only* jumper cables of sufficiently large **cross section** to safely carry the starter current. Refer to the manufacturer's specifications.

Use only jumper cables which have *insulated* terminal clamps and are properly marked for distinction:

plus (+) cable: in most cases colored **red**

minus (-) cable: in most cases colored **black**

WARNING

Batteries contain electricity, acid, and gas. Any of these can cause very serious or fatal injury. Follow the instructions below for safe handling of your vehicle's battery.

- Always shield your eyes and avoid leaning over the battery whenever possible.
- A discharged battery can already freeze at temperatures just below 32 °F (0 °C). Before connecting a jumper cable, the frozen battery must be thawed completely, otherwise it could explode.
- Do not allow battery acid to contact eyes or skin. Flush any contacted area with water immediately.

WARNING (continued)

- Improper use of a booster battery to start a vehicle may cause an explosion.
- Vehicle batteries generate explosive gases. Keep sparks, flame and lighted cigarettes away from batteries.
- Do not try to jump start any vehicle with a low acid level in the battery.
- The voltage of the booster battery must also have a 12-Volt rating. The capacity (Ah) of the booster battery should not be lower than that of the discharged battery. Use of batteries of different voltage or substantially different "Ah" rating may cause an explosion and personal injury.
- Never charge a frozen battery. Gas trapped in the ice may cause an explosion.
- Never charge or use a battery that has been frozen. The battery case may have been weakened.
- Use of batteries of different voltage or substantially different capacity (Ah) rating may cause an explosion and injury. The capacity (Ah) of the booster battery should not be lower than that of the discharged battery.
- Before you check anything in the engine compartment, always read and heed all WARNINGS ⇒ *page 191*, "Working in the engine compartment".

Note

- Applying a higher voltage booster battery will cause expensive damage to sensitive electronic components, such as control units, relays, radio, etc.
- There must be no electrical contact between the vehicles as otherwise current could already start to flow as soon as the positive (+) terminals are connected. ▶

Tips

- The discharged battery must be properly connected to the vehicle's electrical system.
- Switch off any car phone, or follow the car phone instructions for this situation. ■

Use of jumper cables

Make sure to connect the jumper cable clamps in exactly the order described below!

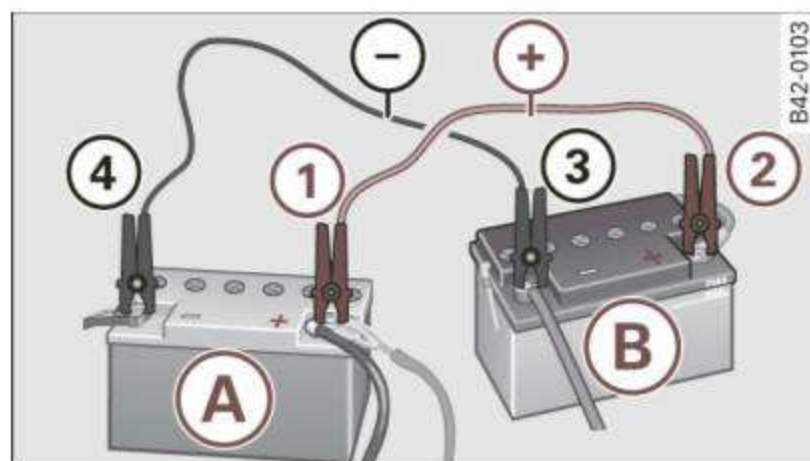

Fig. 136 Jump start using the battery in another vehicle: A - Discharge, B - Female socket

The battery is located in the luggage compartment
 ⇒ page 202. The front lid can be opened in an emergency
 ⇒ page 50.

Connect the positive cable (red) to the positive terminal

1. Connect one end of the red jumper cable ⇒ fig. 136 ① to the positive terminal of discharged battery (A).
2. Connect the other end of the red jumper cable to the positive terminal ② of the booster battery (B).

Connect the negative cable (black) to the negative terminal

3. Connect one end of the black jumper cable ③ to the negative terminal of the booster battery (B).
4. Connect the other end of the black jumper cable ④ to the negative terminal of the discharged battery (A).

Starting the engine

- Start the engine of the vehicle providing assistance and allow it to run at idle.
- Now start the engine of the vehicle with the discharged battery.
- If the engine does not start: Stop trying after 10 seconds and then try again after about 30 seconds.
- Disconnect the cable while the engine is running in exactly *reverse* order to that described.

The battery is vented to the outside to prevent gases from entering the vehicle interior. Make sure that the jumper clamps are well connected with their *metal parts in full contact* with the battery terminals.

WARNING

To avoid serious personal injury and damage to the vehicle, heed all warnings and instructions of the jumper cable manufacturer. If in doubt, call for road service.

- Jumper cables must be long enough so that the vehicles do not touch.
- When connecting jumper cables, make sure that they cannot get caught in any moving parts in the engine compartment. ▶

⚠ WARNING (continued)

- Before you check anything in the engine compartment, always read and heed all WARNINGS ⇒ *page 191, "Working in the engine compartment"*.

⚠ Note

Improper hook-up of jumper cables can ruin the generator.

- Always connect POSITIVE (+) to POSITIVE (+), and NEGATIVE (-) to NEGATIVE (-) ground post of the battery manager control unit.
- Check that all screw plugs on the battery cells are screwed in firmly. If not, tighten plugs prior to connecting clamp on negative battery terminal.
- Please note that the procedure for connecting a jumper cable as described above applies specifically to the case of your vehicle being jump started. When you are giving a jump start to another vehicle, do *not* connect the negative (-) cable to the negative (-) terminal on the discharged battery ④. Instead, securely connect the negative (-) cable to either a solid metal component that is firmly bolted to the engine block or to the engine block itself. If the battery that is being charged does not vent to the outside, escaping battery gas could ignite and explode! ■

Emergency towing with commercial tow truck

General hints

Your Audi requires special handling for towing.

The following information is to be used by commercial tow truck operators who know how to operate their equipment safely.

- Never tow your Audi, towing will cause damage to the engine and transmission.

- Never wrap the safety chains or winch cables around the brake lines.
- To prevent unnecessary damage, your Audi must be transported with a car carrier (flatbed truck).
- To load the vehicle on to the flat bed, use the towing loop found in the vehicle tools and attach to the front anchorage ⇒ *page 243*.

⚠ WARNING

A vehicle being towed is not safe for passengers. Never allow anyone to ride in a vehicle being towed, for any reason.

⚠ Note

The vehicle has very low ground clearance. Make sure that no damage is caused to the underside of the vehicle when it is being loaded onto a flat bed truck. ■

Front towing loop

Do not install the front towing loop until it is needed.

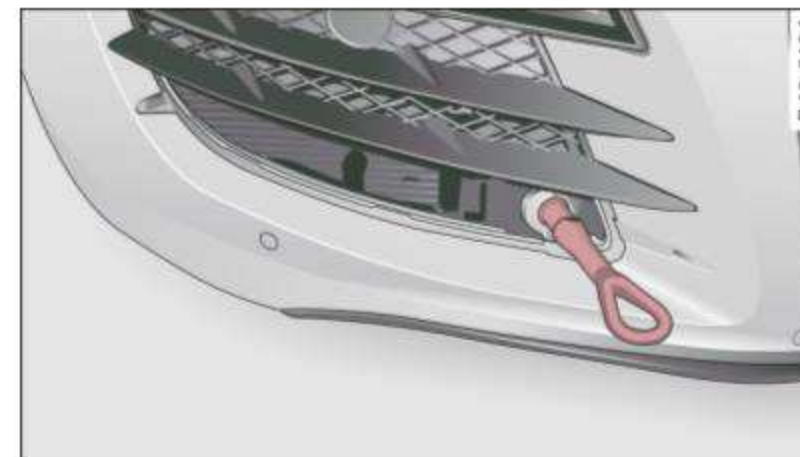

Fig. 137 Right front bumper without grille: Towing loop fully screwed in

On the right front in the bumper, there is a threaded hole behind the air intake grill into which the towing loop is screwed.

- Remove the towing loop from the vehicle tool kit
⇒ *page 232*.
- Pull the lower part of the grill forward and out.
- Screw the towing loop tightly into the threaded hole as far as it will go ⇒ *fig. 137*.

When it is no longer needed, unscrew the towing loop and put it back into the on-board toolkit. Make sure to have the towing loop stored in the vehicle at all times.

When installing the grill for the air duct, be sure that the tabs on the grill are first inserted into their guides on the vehicle. Then push the grill into position.

 **WARNING**

If the towing loop is not screwed in as far as it will go, the thread can pull out when the vehicle is towed - potential risk of an accident.

 **Tips**

Check carefully to make sure the hook-up is secure ■

Fuses and bulbs

Fuses

Replacing a fuse

Burned out fuses must be replaced.

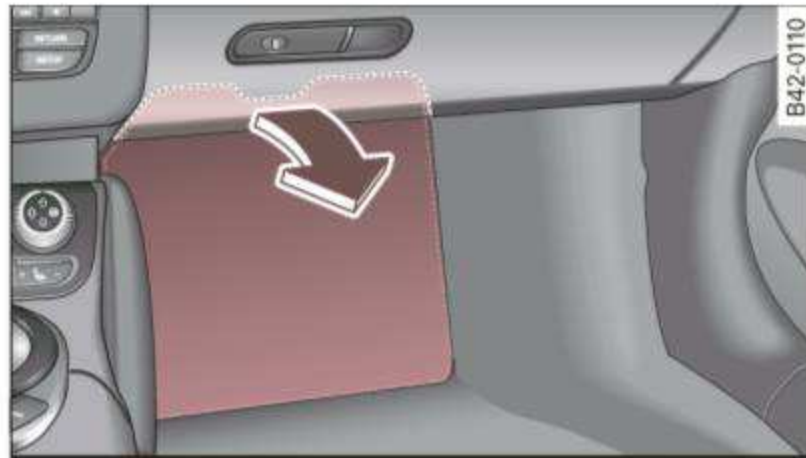

Fig. 138 Passenger's side wheel well: Foot rest with fuse arrangement

The individual circuits are protected by fuses. The fuses are in the footwell area on the passenger's side behind a cover.

- Switch off the ignition and the electrical component affected.
- Remove the floor mat.
- Fold the foot rest back ⇒ fig. 138.
- Check the fuse listing on the next pages to find out which fuse belongs to the component which has failed ⇒ *page 246, "Fuse arrangement"*.
- Remove the blown fuse with the plastic clip provided. The clip is located on the holder in the fuse box.
- Replace a blown fuse (recognizable by the melted metal strip inside) with a fuse of the *same* amperage.

- Fold the foot rest down again.

WARNING

Never replace a fuse with one that has a higher amperage rating.

- A fuse with a too high amperage could damage the electrical part and cause a fire.

Note

On no account should fuses be repaired (e.g. patched up with tin foil or wire) as this may cause serious damage elsewhere in the electrical circuit or cause fire.

Tips

- If a fuse blows repeatedly, do not keep replacing it. Instead, have the cause for the repeated short circuit or overload tracked and fixed.
- You are well advised to keep a supply of spare fuses in your vehicle. Fuses with the proper ampere ratings are available at your authorized Audi dealer. ■

Fuse arrangement

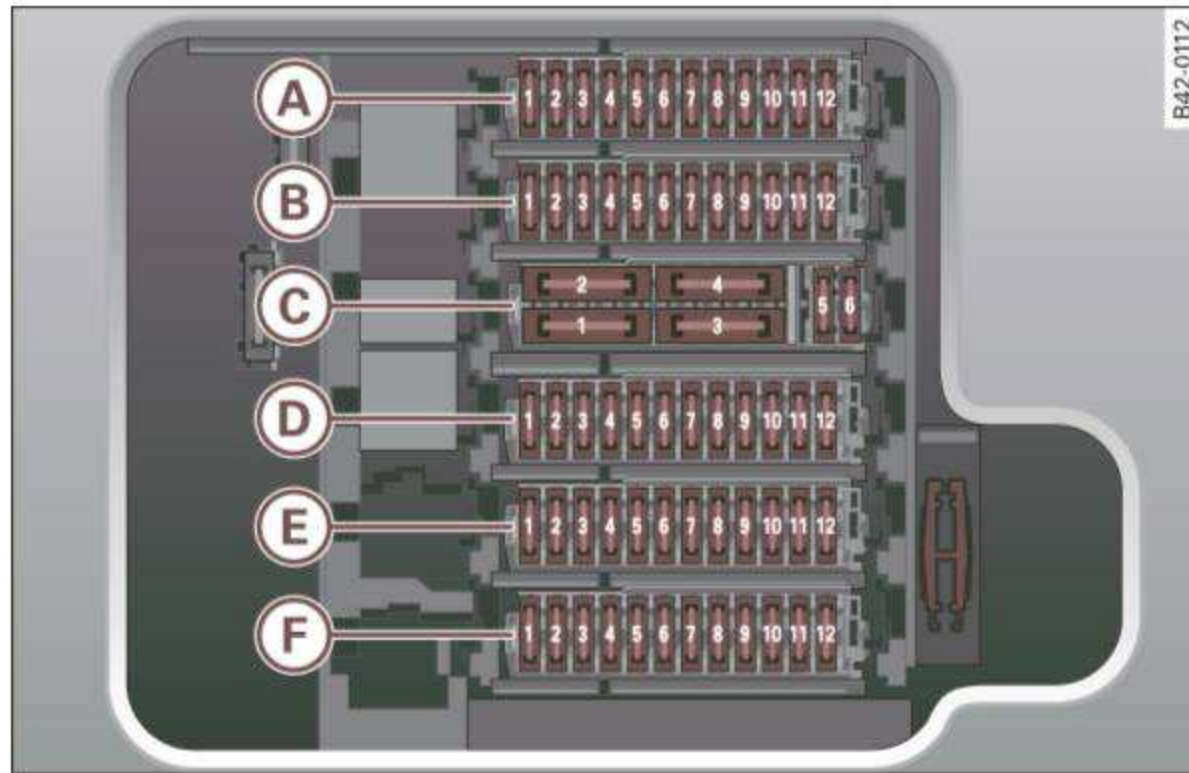

Fig. 139 Fuse arrangement in the passenger's footwell, row A to F

The fuse panel is located in the passenger's footwell behind the foot rest ⇒ fig. 139.

Fuse row (A) is not used.

Row	No	Equipment	Amps
(B)	1	Not used	--
	2	Heated windshield washer nozzle	5
	3	Audi Parking System (APS)	10
	4	Not used	--
	5	Diagnostic interface, light switch, Airbag OFF indicator light, selector lever	10
	6	Networking gateway, diagnostic interface	5
	7	Not used	--
	8	EC rear view mirror, garage door opener	10
	9	Washer pump	15
	10	ESP button	10
	11	Pressure sensor, climate controls	5
	12	Airbag	5

Fuse row -B-

Row	No	Equipment	Amps
(C)	1	Radiator fan (1)	40
	2	Radiator fan (2)	40
	3	Exterior lighting	40
	4	Exterior lighting	40
	5	Not used	--
	6	Blower regulator	40

Fuse row -C-

Row	No	Equipment	Amps
D	1	Rear view camera	5
	2	Tire Pressure Monitoring System	10
	3	Audi Parking System (APS)	5
	4	Cell phone package	5
	5	Instrument cluster	5
	6	Networking gateway	5
	7	Switch for steering column	5
	8	Diagnostic interface, brake pedal switch, selector lever	10
	9	Rain/light sensor	5
	10	Interior light	5
	11	Sound amplifier	30
	12	Radio	20

Fuse row -D-

Row	No	Equipment	Amps
E	1	Not used	--
	2	Not used	--
	3	Auxiliary water pump	10
	4	Special equipment	5
	5	Supply terminal 15, starter	30
	6	Pump for brake booster	15
	7	Horn	20
	8	Wiper motor	30
	9	Wiper motor	30
	10	Not used	--
	11	Electric rear window defogger	30
	12	Power outlets and cigarette lighter	20

Fuse row -E-

Row	No	Equipment	Amps
F	1	Electronic Stabilization Program	10
	2	Electronic Stabilization Program	25
	3	Not used	--
	4	Not used	--
	5	Convenience control module	20
	6	Convenience control module	20
	7	Level sensor (ASS), anti-theft alarm system	5
	8	A/C	10
	9	Heated seat	25
	10	Lumbar support	10
	11	Power windows	30
	12	Control module for doors	10

Fuse row -F-

Some of the equipment items listed are optional or only available on certain model configurations.

The electrically heated seats are protected by **circuit breakers** which switch on again automatically after a few seconds when the overload is removed.



Tips

Note that the tables above are accurate at the time of going to press and are subject to change. In the event of discrepancies, the label on the inside of the cover always takes precedence. ■

Bulbs

Note

Your vehicle is equipped with maintenance-free headlights and rear lights. However, if a bulb has to be changed, please consult your authorized Audi dealer or other qualified workshop. ■



General information

Explanation of technical data

Some of the technical data listed in this manual require further explanation.

The technical data for your vehicle are listed in the charts starting on ⇒ page 254. This chapter provides general information, notes and restrictions which apply to these data. ■

Vehicle identification

The key data are given on the vehicle identification number (VIN) plate and the vehicle data sticker.

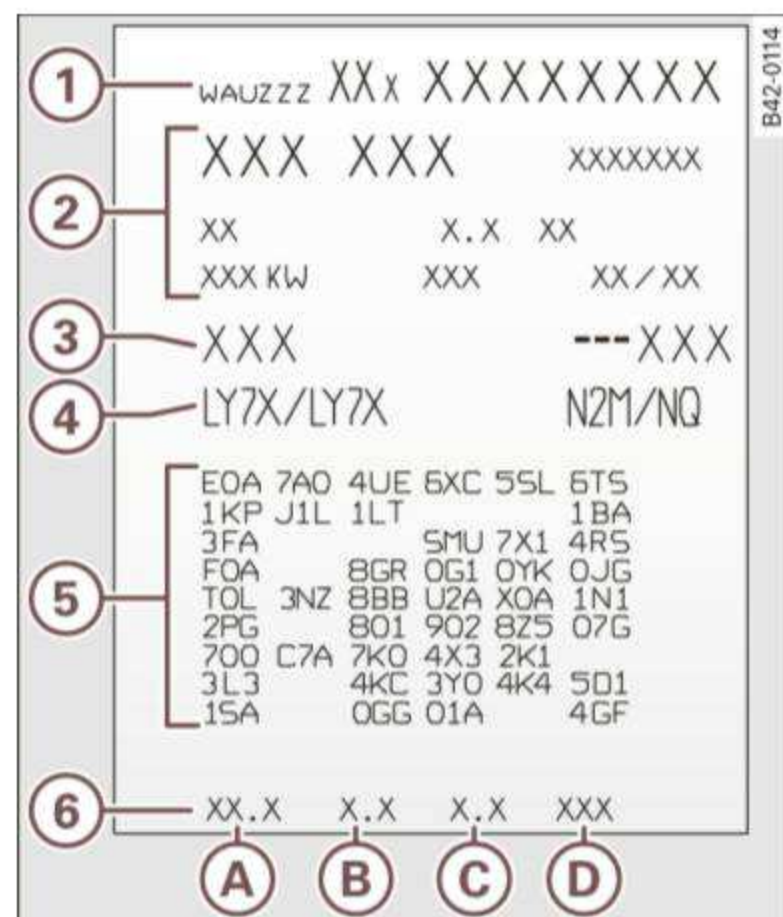

Fig. 140 The vehicle identification label

The Vehicle Identification Number (VIN)

You can find the Vehicle Identification Number (VIN) behind the windshield on the lower left side. You can also display the Vehicle Identification Number of your vehicle in the Driver Information display ⇒ page 26.

The vehicle identification label

The vehicle identification label ⇒ fig. 140 is located with the fuses in the footwell on the passenger's side ⇒ page 245.

The label shows the following vehicle data:

- ① Vehicle Identification Number (chassis number)
- ② Vehicle model/engine output/transmission
- ③ Engine and transmission codes
- ④ Paint and interior equipment numbers
- ⑤ Optional equipment numbers
- ⑥ Fuel economy and emissions data

Vehicle data are also found in your Warranty & Maintenance booklet.

The safety compliance sticker

The safety compliance sticker is your assurance that your new vehicle complies with all applicable Federal Motor Vehicle Safety Standards which were in effect at the time the vehicle was manufactured. You can find this sticker on the left door jamb. It shows the month and year of production and the vehicle identification number of your vehicle (perforation) as well as the Gross Vehicle Weight Rating (GVWR) and the Gross Axle Weight Rating (GAWR).

The high voltage warning label

The high voltage warning label is located on the lock carrier.

The spark ignition system meets all requirements of the Canadian Interference-Causing Equipment Regulations. ■

Weights

Gross Vehicle Weight Rating

The Gross Vehicle Weight Rating (GVWR), and the Gross Axle Weight Rating (GAWR) for front and rear are listed on a sticker on the left door jamb.

The Gross Vehicle Weight Rating includes the weight of the basic vehicle plus full fuel tank, oil and coolant, plus maximum load, which includes passenger weight (150 lbs/68 kg per designated seating position) and luggage weight.

Gross Axle Weight Rating

The Gross Axle Weight Rating is the maximum load that can be applied at each axle of the vehicle ⇒ ⚠.

Vehicle capacity weight

The vehicle capacity weight (max. load) is listed either on the driver's side B-pillar.

WARNING

- **The actual Gross Axle Weight Rating at the front and rear axles should not exceed the permissible weights, and their combination must not exceed the Gross Vehicle Weight Rating.**
- **Exceeding permissible weight ratings can result in vehicle damage, accidents and personal injury.**

Note

- The vehicle capacity weight figures apply when the load is distributed evenly in the vehicle (passengers and luggage). When transporting a heavy load in the luggage compartment, carry the load as near to the rear axle as possible so that the vehicle's handling is not impaired.
- Do not exceed the maximum permissible axle loads or the maximum gross vehicle weight. Always remember that the vehicle's

handling will be affected by the extra load. Therefore, adjust your speed accordingly.

- Always observe local regulations. ■

Data

R8 4.2 quattro

Engine data

Maximum output SAE net	420 hp (309 kW) @ 7800 rpm
Maximum torque SAE net	317 lb-ft (430 Nm) @ 4500 - 6000 rpm
Cylinders, Displacement	8 cylinders, 254 CID (4163 cm ³)
Number of valves per cylinder	4
Bore	3.33 in (84.5 mm)
Stroke	3.65 in (92.8 mm)
Compression ratio	12.5:1
Firing sequence	1-5-4-8-6-3-7-2
Fuel	Premium unleaded (91 AKI) Recommended for maximum engine performance. Further details ⇒ <i>page 186, "Gasoline"</i>

Engine oil

Engine oil with filter change	quarts/ liters	approx. 10.6/10
-------------------------------	-------------------	--------------------

Dimensions

Length (with license plate bracket)	4431 mm (approx. 174.5 in)
Width	1904 mm (approx. 75.0 in)
Width (across mirrors)	2029 mm (approx. 80.0 in)
Height (unloaded)	1252 mm (approx. 49.3 in)
Turning circle diameter (curb to curb)	11.80 m (approx. 38.7 ft)

When driving up steep ramps, on rough roads, over curbs, etc. it is important to remember that some parts of your vehicle, such as spoilers or exhaust system components, may be close to the ground. Be careful not to damage them.

This applies especially to vehicles with a low chassis (sports chassis) and when the vehicle is fully loaded. ■

Capacities (approx.)

Fuel tank

Total capacity	gal/liters	24/90
Reserve (of total capacity)	gal/liters	2.6/10

Windshield washer system

Windshield washer fluid	quarts/ liters	approx. 4.2/4,0
-------------------------	-------------------	--------------------

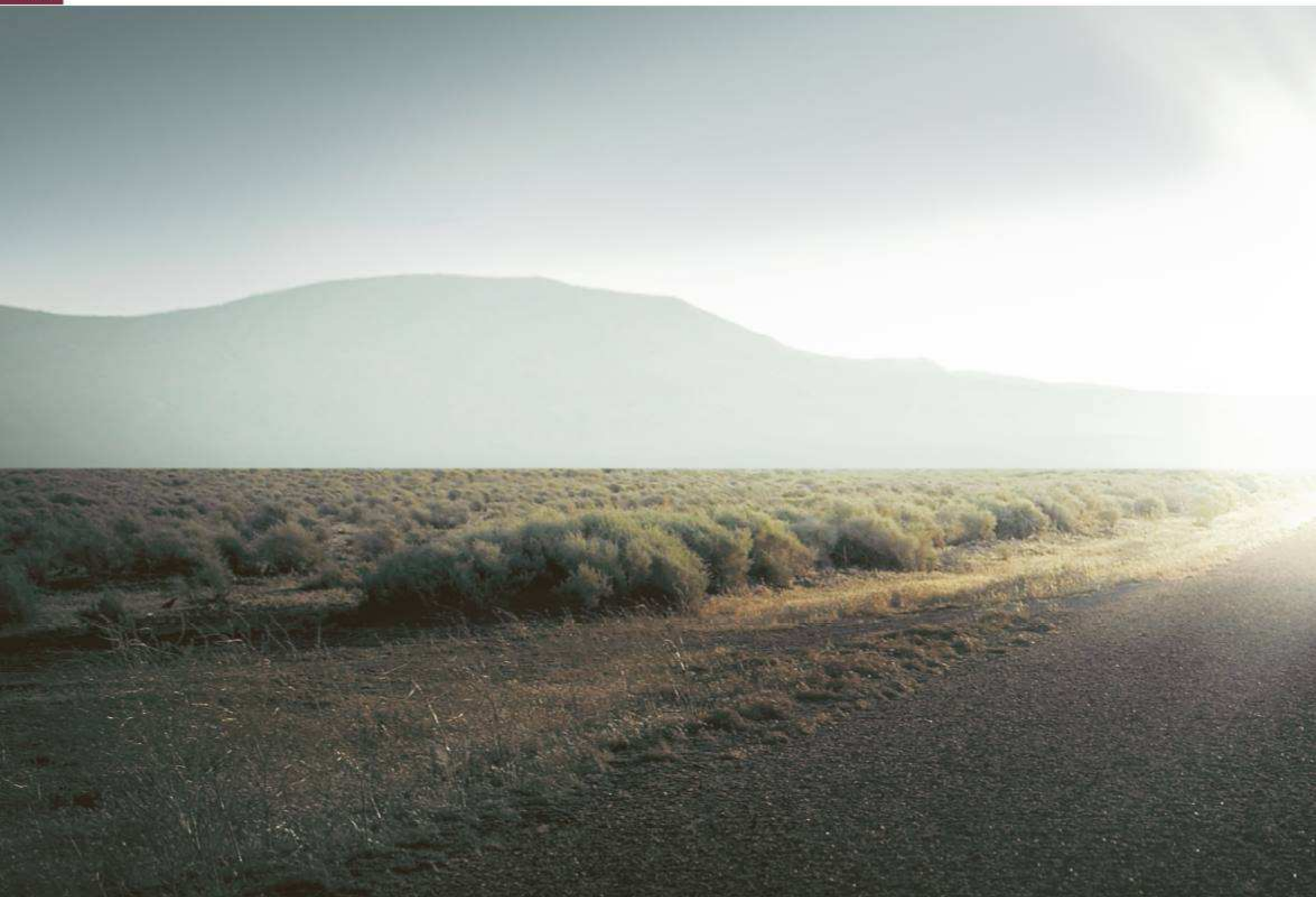

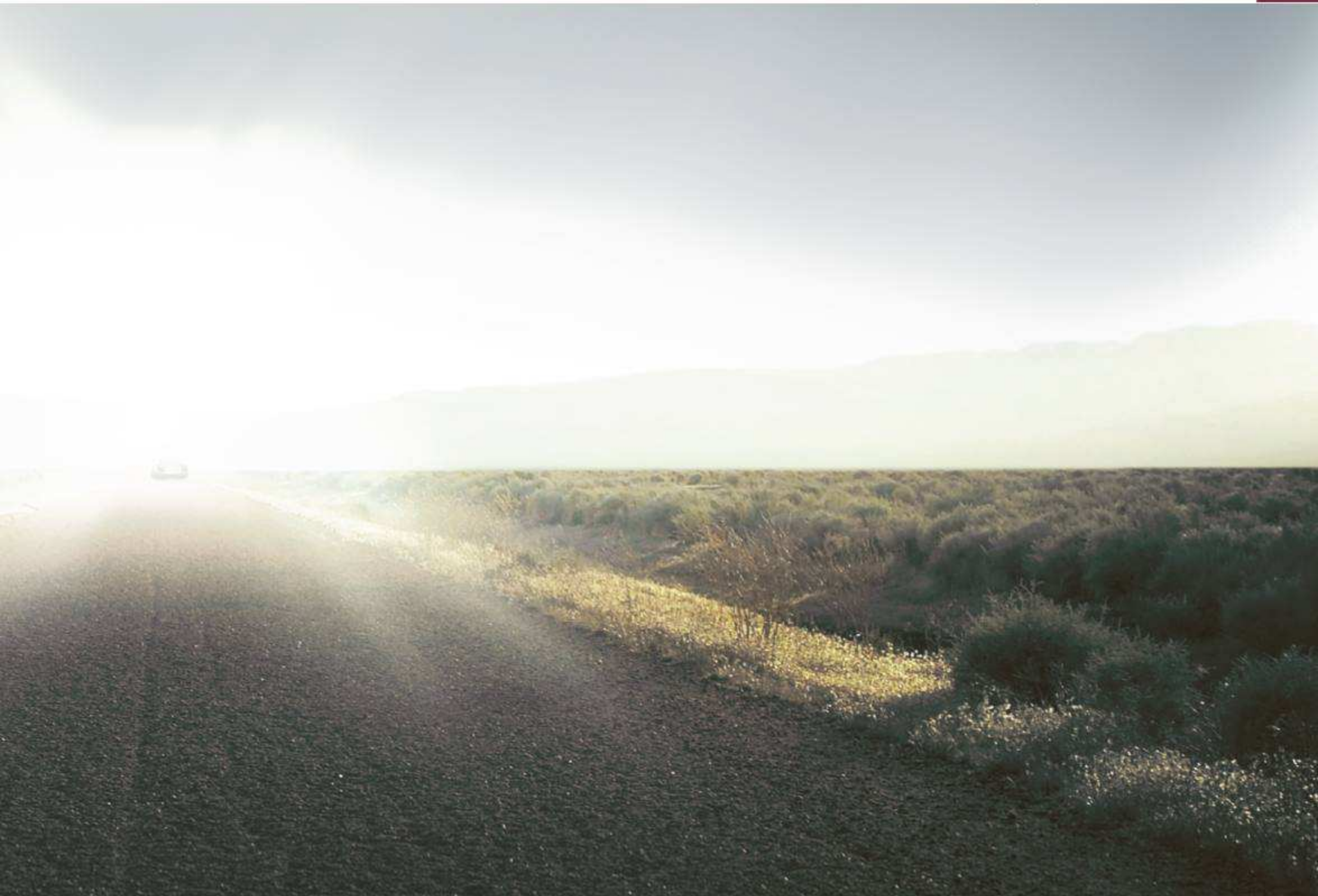

- (R tronic) transmission 88
- A**
- A/C operation 78
- ABS
 See Anti-Lock Brake System 164
- Accessories 227
- Acoustic park assist
 Description 93
 General Information 93
 Instructions 94
 Switching the system On/Off 93
- Adding
 Engine coolant 199
 Engine oil 196
- Additional accessories 227
- Additives 196
- Adjustable steering column 80
- Adjusting front seats 67
- Advanced Airbag System
 Children 148
 Components 132
 Front airbags 130
 How the components work together 133
 Monitoring 136
 Weight-sensing mat 148
- Air conditioning
 A/C operation 78
 Air distribution 76
 Air recirculation mode 77
- Automatic mode 77
- Controls 74
- Defrost 77
- Economical use 78
- Fan 76
- Heated seats 79
- Rear window defogger 78
- Switching on and off 76
- Temperature 75
- Air distribution 76
- Air recirculation mode
 Air conditioning 77
- Airbag
 Warning/indicator lights 19
- Airbag system 125, 145
- Care 139
- Child restraints 149
- Components (front airbags) 132
- Danger of fitting a child safety seat on the front passenger seat 127
- Disposal 139
- Front airbags 129
- How do the front airbags work? 134
- How many airbags does my vehicle have? 132
- Important safety instructions on the knee airbag system 143
- Important things to know 125
- Indicator light 136
- Knee airbags 141
- Monitoring 136
- PASSENGER AIR BAG OFF light 137
- Service 139
- Side airbags 144
- When must the system be inspected? ... 136
- All Wheel Drive 169
- All-wheel drive
 Winter tires 220
- Anti-freeze
 See Engine coolant system 197
- Anti-glare inside day-night mirror 63
- Anti-Lock Brake System 164
- Anti-lock brake system
 Warning/indicator lights 20
- Anti-Slip Regulation System 164
- Anti-theft alarm 47
- Anti-theft alarm system 50
- Anti-theft systems 44
- Anti-theft wheel bolts 237
- Ashtray 71
- ASR
 See Anti-Slip Regulation System 164
- Asterisk 6
- Audi magnetic ride 17, 86
 Description 86
 Indicator light 17
- Audi parking system
 See Acoustic park assist 93
 See Rearview camera 95
- Audi Service Repair Manuals and Literature . 225
- Auto Safety Hotline 114
- Automated manual transmission
 See R tronic 88

- Automatic belt retractor 120
 - Automatic car wash
 - See Washing 176
 - Automatic headlight 54
 - Automatic headlight control 63
 - Automatic headlights
 - defective 41
 - Average fuel mileage 25
 - Average speed 25
- B**
- Battery 200
 - Charging 203
 - Checking 200
 - Disconnecting 200
 - Replacing the battery 201
 - Vehicles not driven for long periods . 201
 - Winter operation 200, 201
 - Working on the battery 202
 - Battery voltage 40
 - Before driving 106
 - Blended gasoline 186
 - Booster seats 154
 - How do I properly install a booster seat in my vehicle? 154
 - Safety instructions 154
 - Brake system
 - Brake fluid 200
 - Brake light defective 40
 - Brake power assist unit 167
 - Brakes 167
 - Malfunction 37
 - Warning/indicator lights 19
 - Worn brake pads 39
 - Break-in 170
 - Bulbs 248
- C**
- California Proposition 65 Warning 192
 - Battery specific 203
 - Capacities 254
 - Car care 176
 - Car key 42
 - Carbon-fiber
 - Interior 180
 - Carbon-fiber parts
 - Exterior 178
 - Cargo area
 - See Luggage compartment 113
 - Catalytic converter 170
 - Ceramic brake discs
 - Changing a wheel 239
 - Certification 228
 - Changing a flat tire 237
 - Chassis
 - See Audi magnetic ride 86
 - Checking
 - Engine coolant level 198
 - Checking tire pressure 211
 - Child restraint
 - Danger of using child restraints in the front seat 127
 - Child restraints
 - Where can I get additional information about child restraints? 161
 - Child safety 147, 152
 - Booster seats 154
 - Convertible child safety seats 153
 - Convertible locking retractor 156
 - Important safety instructions for using child safety seats 150
 - Important things to know when driving with children 147
 - Infant seats 152
 - Older children and safety belts 156
 - Safety belts and older children 156
 - Tether strap 159
 - Which restraint system should my older child wear? 156
 - Child safety seat 152
 - Convertible locking retractor 156
 - Installing 156
 - Child safety seats
 - How do I properly install a child safety seat in my vehicle? 150
 - Safety instructions 150
 - Cigarette lighter 71
 - Cleaning
 - Alcantara (synthetic suede) 183
 - Engine compartment 184
 - Fabrics and fabric coverings 180
 - Leather 182
 - Safety belts 184
 - Cleaning and protection 176

- Climate controls 74
 - Dust filter 74
 - Heating 74
 - Pollen filter 74
 - Ventilation 74
 - Clock 13
 - Closing
 - Engine compartment lid 192
 - Clutch overheating 41
 - Coat hooks 73
 - Cold tire inflation pressure 209
 - Coming-home-function 55
 - Compass mirror 65
 - Compliance 228
 - Consumer Information 114, 225
 - Contacting NHTSA 114
 - Controls and displays 11
 - Convenience close/open feature 47
 - Convertible child seats
 - How do I properly install a convertible child seat in my vehicle? 153
 - Safety instructions 153
 - Convertible locking retractor
 - Activating 158
 - Deactivating 159
 - Using to secure a child safety seat .. 156, 158
 - Coolant System
 - Adding coolant 199
 - Checking the engine coolant level .. 198
 - Coolant system 197
 - Radiator fan 199
 - Cruise control 84
 - Changing speed 85
 - Deactivating 86
 - Driving in control mode 85
 - Switching off temporarily 86
 - Warning/indicator lights 19
 - Cup holder 70
 - Current fuel mileage 25
- D**
- Damping
 - See Audi magnetic ride 86
 - Data 254
 - Data recorder 164
 - Date display 13
 - Daytime running lights 53
 - Declaration of compliance
 - Cell phone package 228
 - Electronic immobilizer 228
 - HomeLink® universal remote control 228
 - Remote control key 228
 - Tire pressure monitoring system ... 228
 - def 15
 - Defective light bulb warning 40
 - Defrosting the windows 77
 - Description R tronic 88
 - Determining correct load limit 213
 - Digital compass 65
 - Dimensions 254
 - Dipstick 195
 - Distance 25
- Doors
 - Emergency locking 48
 - Driver information 36
 - Driver information system
 - Menu button 28
 - Menu display 26
 - Open door or front lid warning 22
 - Outside temperature display 22
 - Red symbols 35
 - Service interval display 23
 - Setting 29
 - Sound system display 22
 - Trip computer 25
 - yellow symbols 35
 - Driver seat
 - See Seating position 108
 - Driving safely 106
 - Dry sump lubrication 169
 - Duplicate key 42
 - Dust filter 75
- E**
- EDL
 - See Electronic Stabilization Program 164
 - Elapsed time 25
 - Electrical voltage 15
 - Electronic differential lock 164
 - Electronic differential lock (EDL)
 - Warning/indicator lights 20
 - Electronic immobilizer 15, 44
 - Electronic Stabilization Program 164

- Emergency flasher 57
 Warning/indicator lights 18
- Emergency key 42
- Emergency locking 48
- Emergency release
 Front lid 50
- Emergency starting 241
- Emergency towing 243
- Engine
 Coolant 197
 Engine compartment lid 191
 Starting 81
 Stopping 82
- Engine compartment 193
 Lights 59
 Safety instructions 191
- Engine compartment lid
 Closing 192
 Release lever 191
- Engine coolant system 197
 Temperature gauge 13
- Engine cooling system
 Malfunction 37
- Engine data 254
- Engine oil 193
 Adding 196
 Additives 196
 Checking the engine oil level 195
 Dry sump lubrication 169
 Indications and conditions requiring extra
 checking 195
 Oil consumption 195
 Oil grades 193
 Specification and viscosity 193
 Temperature display 12
- Engine oil level 39
- Engine oil pressure (malfunction) 38
- Engine oil sensor defective 39
- Environment
 Catalytic converter 170
 Fuel 188
 Unleaded fuel 186
- EPC-indicator light 18
- ESP 18
See also Electronic Stabilization Program
 164
- Event Data Recorder (EDR) 164
- Expansion tank 198
- ## F
- Fan 76
- Flat bed truck 243
- Flat tire
 Changing 237
- Floor mats 112
- Foot pedals 112
- For the sake of the environment
 Gasoline fumes and the environment 188
 Letting your engine warm up 81
 Refueling 188
- Front airbags
 Description 129
 How they work 134
- Front lid
 Emergency release 50
 light 59
 Power locking system 49
 Trunk escape handle 232
- Front passenger
See Seating position 109
- Front seats 67
 Child restraints in the front seat 127
- Front towing loop 243
- Frontal collisions and the laws of physics ..
 119
- Fuel
 Additives 186
 Blended gasoline 186
 Current fuel mileage 25
 Filler neck 187
 Fuel supply too low 38
 Gasoline additives 187
 Octane rating 186
 Recommendation 186
 Refueling 188
 Reserve 14
 Tank capacity 254
 Unlocking the fuel filler flap by hand 190
- Fuel gauge 14
- Fuel range 25
- Fuse 245
- Fuse arrangement 246
- ## G
- Garage door opener 100

- Generator
Warning/indicator lights 19
- Glossary of tire and loading terminology ... 206
- Glove compartment 72
- Gross Vehicle Weight Rating (GVWR) ... 253
- ## H
- Head restraints 70, 110
Adjusting 110
- Headlight
defective 40
- Headlight flasher 58
- Headlights 53
- Heated
Front seats (air conditioning) 79
Outside mirrors 64
Rear window defogger 78
Seats 79
Washer jets 59
- Heated seats 79
- Heating 74
- High beam 53, 57
- High voltage warning label 252
- Hill hold assist
Starting on hills 84
- HomeLink® 100
- HomeLink® universal remote control .. 100
- Horn 11
- How many airbags does my vehicle have? .. 132
- How often should I check my tire pressures? 212
- How safety belt pretensioners work 123
- Hydroplaning 215
- ## I
- Ignition 81
- Immobilizer 15
- Important things to do before driving .. 106
- Improperly worn safety belts 123
- Indicator light
Airbag system 136, 137
Audi magnetic ride 17
Clutch overheating 41
No reverse gear 41
PASSENGER AIR BAG OFF 137
Selector lever defective 41
- Indicator lights 16
Red symbols in the center display ... 35
Yellow symbols in the center display . 35
- Infant seats 152
How do I properly install an infant seat in my vehicle? 152
Safety instructions 152
- Installing child safety seats
Safety belts 156
- Instrument cluster and controls 12
- Instrument panel illumination 56
- Instruments and controls
General illustration 11
- Interior lights 58
Engine compartment 59
Luggage compartment 59
- Intermittent wiping 59
- ## J
- Jump-starting 241
- ## K
- Key 42
Battery replacement 43
Emergency key 42
Key replacement 42
Remote master key 42
- Kick-down
R tronic 90
- Knee airbags 141
Description 141
How they work 142
Important safety instructions 143
- ## L
- Lap Timer
Einführung 29
Selecting 30
- Lap timer
Deleting total results 32
Displaying split time 31
Ending timing 32
Evaluating times 32
Interrupting timing 31

- Resuming timing 33
 - Starting timing 30
 - Switching to the trip computer 32
 - Launch Control Program
 - R tronic 90
 - Leather 181
 - Cleaning 182
 - Leaving-home-function 55
 - Lifting jack 237
 - Light sensor package 54
 - Light/rain sensor
 - Automatic headlight control 63
 - Light sensor package 54
 - Wiper and washer system (intermittent wiping) 59
 - Light/rain sensor defective 41
 - Lights
 - Instrument panel illumination 56
 - switching on and off 53
 - Loading the luggage compartment 113
 - Locking 46
 - Power locking system 47
 - Locking and unlocking the vehicle from inside
 - Power locking system 47
 - Luggage compartment 59
 - Emergency exit 232
 - light 59
 - Loading 113
- M**
- Maintenance 226
 - Malfunction Indicator Lamp (MIL) 24
 - Manual glare dimming
 - See Mirrors 63
 - Menu button 28
 - Menu display 26
 - Mirror
 - Vanity mirror 59
 - Mirrors
 - Activating the digital compass 65
 - Automatic dimming for the outside mirrors 65
 - Automatically dimming inside mirror . 63
 - Manual glare dimming 63
 - Outside mirrors 64
 - Monitoring the Advanced Airbag System .. 136
- N**
- Natural leather 181
 - New tires and wheels 216
 - NHTSA
 - Contacting 114
 - No reverse gear 41
 - Number of seats 116
- O**
- Octane rating 186
 - Odometer 15
 - Oil
 - See Engine oil 193
 - Older children and safety belts 156
 - On-Board Diagnostic System (OBD)
 - Data Link Connector (DLC) 24
 - Malfunction Indicator Lamp (MIL) 24
 - Open door or front lid warning 22
 - Optional equipment
 - Marked with an asterisk 6
 - Outside mirrors 64
 - Outside temperature display 22
 - Owner's manual
 - How the Owner's Manual is organized . 6
- P**
- Paint
 - Touch-up 179
 - Paint No. 252
 - Park assist
 - See Rearview camera 95
 - Parking
 - on a decline 83
 - on an incline 83
 - R tronic 89
 - Parking brake 83
 - Parking brake warning 37
 - Parking system
 - See Acoustic park assist 93
 - See Rearview camera 95
 - Parts replacement 227
 - PASSENGER AIR BAG OFF light 137
 - Passive safety system 106
 - Pedals 112
 - Physical principles of a frontal collision . 119

- Polishing 176
 Pollen filter 75
 Pollutant filter 75
 Power locking system 44
 Anti-theft alarm 47
 Emergency locking 48
 Front lid 49
 Locking 47
 Locking and unlocking the vehicle from
 inside 47
 Opening/closing the windows 46
 Switches 47
 Unlocking 47
 Power seats 68
 Power steering 168
 Power windows 51
 Power locking system 46
 Reactivating the system 52
 Pregnant women
 Special considerations when wearing a
 safety belt 122
 Programming the HomeLink® universal re-
 mote control 100
 Proper safety belt position 121
 Proper seating position
 Driver 108
 Front passenger 109
- Q**
- Quartz clock 13
 quattro®
 See All Wheel Drive 169
- R**
- R tronic 88
 Description 88
 Emergency program 91
 Kick-down 90
 Launch Control Program 90
 Manual operation 89
 Steering wheel with shift paddles ... 91
 Radiator fan 199
 Rain sensor 59
 Rain sensor defective 41
 Rear light defective 40
 Rear spoiler 166
 Rear window defogger 78
 Rearview camera
 Description 95
 Parallel parking 98
 Parking Mode 1 97
 Parking Mode 2 98
 Reverse parking 97
 Safety 95
 Switching the camera On/Off 96
 Rearview mirror
 See Mirrors 63
 Refueling 188
 Remote control
 See Remote master key 43
 Remote control garage door opener
 (HomeLink®) 100
 Remote master key 42
 Battery replacement 42, 43
 Check light 42
 Resetting the remote control 43
 Unlocking and locking 46
 Repair manuals 225
 Replacement parts 227
 Replacing
 Wheel rims 216, 218
 Replacing a fuse 245
 Replacing bulbs 248
 Replacing tires and wheels 216
 Reporting Safety Defects 114
 Reset button 15
 Retractor 120
 Reverse gear
 R tronic 88
 Rims
 Replacing 216, 218
- S**
- SAFE 15, 44
 Safe driving habits 106
 Safety belt position 121
 Safety belts worn by pregnant women ...
 122
 Safety belt pretensioner
 Service and disposal 124
 Safety belt warning light 116
 Safety belts
 Cleaning 184
 Danger to passengers who do not wear a
 safety belt 120
 Fastening 120
 General notes 116

- Improperly worn 123
 - Not worn 120
 - Pretensioners 123
 - Safety belt position 121
 - Safety instructions 118
 - Securing child safety seats 156
 - Special considerations for pregnant women 122
 - Unfastening 122
 - Warning/indicator light 116
 - Warning/indicator lights 19
 - Why you must wear them 117
 - Worn properly 117
 - Safety compliance sticker 252
 - Safety equipment 106
 - Safety features for occupant restraint and protection 106
 - Safety guidelines
 - Seat adjustment 67
 - Safety instructions
 - for booster seats 154
 - for using child safety seats 150
 - for using convertible child seats 153
 - for using infant seats 152
 - For using safety belts 118
 - Monitoring the Advanced Airbag System 138
 - Seat adjustment
 - Driver's seat 67
 - Front passenger's seat 68
 - Front seats 67
 - Head restraints 110
 - Power seats 68
 - Safety guidelines 67
 - Seating capacity 116
 - Seating position
 - Driver 108
 - Front passenger 109
 - Incorrect seat position 111
 - Seats
 - Number of seats 116
 - Selector lever defective 41
 - Service
 - Airbag system 139
 - Service and disposal
 - Safety belt pretensioner 124
 - Service interval display 23
 - Service position for windshield wipers .. 61
 - Set menu 29
 - Setting the time 13
 - Side airbags
 - Description 144
 - How they work 145
 - Side marker lights 53
 - Snow chains 221
 - Socket 71
 - Sound system display 22
 - Speed rating letter code 217
 - Speed warning 39
 - Speed warning system 33
 - Speedometer 15
 - Spoiler 166
 - Starting on hills
 - Hill hold assist 84
 - Starting the engine 81
 - Seating capacity 116
 - Steering column
 - Adjusting 80
 - Locking the steering 81
 - Steps for determining correct load limit 213
 - Stopping the engine 82
 - Storage 72
 - Sun visors 59
 - Symbols
 - Red symbols in the center display 35
 - Yellow symbols in the center display . 35
- T**
- Tachometer 13
 - Tank flap
 - Unlocking the fuel filler flap by hand 190
 - Technical modifications 228
 - Temperature 75
 - Tether strap 159
 - Securing the upper tether strap 160
 - Tire
 - Pressure 223
 - Tire pressure monitoring system 223
 - Tire mobility system 233
 - Tire pressure 211, 223
 - Tire pressure monitoring system 223
 - Loss of air pressure 39
 - Malfunctions 39
 - Sensors 218
 - Tires and wheels 218
 - Valves 218
 - Warning/indicator lights 17
 - Tire repair kit 233

- Tire service life 215
- Tires 205
- Replacing 216, 218
 - Service life 215
 - speed rating letter code 217
 - Tire manufacturing date 217
 - Tire specifications 217
 - Tread depth 215
 - Uniform tire quality grading 219
 - Winter tires 220
- Tires and vehicle load limits 213
- Tires and wheels
- Checking tire pressure 211
 - Cold tire inflation pressure 209
 - Dimensions 216
 - General notes 205
 - Glossary of tire and loading terminology
206
 - New tires and wheels 216
 - Replacing 216
 - Snow chains 221
 - Tire pressure monitoring system ... 218
 - Tires and vehicle load limits 213
 - Wheel bolts 222
 - Winter tires 220
- Tires/Wheels
- Low aspect ratio tires 222
- Tool kit 232
- Touch-up paint 179
- Towing
- Tow truck procedures 243
- Towing loop 243
- Transport Canada 114
- Tread Wear Indicator (TWI) 215
- Trip computer 25
- Trip odometer 15
- Turn signals 57
- ## U
- Unfastening safety belts 122
- Unidirectional tires 205
- Uniform tire quality grading 219
- Universal Radio- Frequency Remote Control
(HomeLink®) 100
- Unlocking 46
- Power locking system 47
- ## V
- Vanity mirror 59
- Vehicle electrical system 19
- Vehicle Identification Number (VIN) 252
- Vehicle jack 237
- Vehicle literature 5
- Vehicle tool kit 232
- Vehicle-care products 176
- Ventilation 74
- Voltmeter display 15
- ## W
- Warning lights 16
- Red symbols in the center display ... 35
 - Yellow symbols in the center display . 35
- Warning/Indicator light
- Rear spoiler 18
- Warning/indicator lights 12
- Airbag system 19
 - Anti-lock brake system 20
 - Brake system 19
 - Cruise control 19
 - Electronic differential lock (EDL) 20
 - Electronic power control (EPC) 18
 - Electronic stabilization program (ESP) 18
 - Generator 19
 - High beam 18
 - Safety belts 19
 - Tire pressure monitoring system 17
 - Turn signals 18
- Warranty coverages 225
- Washing 176
- Waxing 176
- Wear indicator 215
- Weights 253
- What happens if you wear your safety belt too
loose? 121
- What happens to unbelted occupants? . 120
- What impairs driving safety? 107
- What should I do after changing a wheel? ..
212
- What should I do after replacing wheels? ...
212
- Wheel bolts
- Torque 222
- Wheels 180, 205
- Checking tire pressure 211
 - Cold tire inflation pressure 209

General notes	205
Glossary of tire and loading terminology	
206	
New tires and wheels	216
Tires and vehicle load limits	213
When must the airbag system be inspected?	
136	
When should I adjust the tire pressures? ...	
212	
When should I check the tire pressures?	212
Where can I find the tire pressures for my	
car?	211
Why safety belts?	117
Windows	
Cleaning	179
Defrost	77
Deicing	179
Windshield washer fluid	40
Windshield wipers	204
Installing new wiper blades	62
Service position	61
Winter operation	
Battery	200, 201
Coolant system	197
Defrosting windows	77
Heated seats (air conditioning)	79
Windows	179
Windshield wipers	204
Winter tires	220
All-wheel drive	220
Wiper and washer system	59
Wiper blades	
See Windshield wipers	62

It has always been Audi's policy to continuously improve its products. Audi, therefore, reserves the right to make changes in design and specifications, and to make additions or improvements in its products, without incurring any obligation to install them on products previously manufactured.

Text, illustrations and specifications in this manual are based on the most up-to-date information available at the time of printing.

All rights reserved. May not be reproduced or translated in whole or in part without the written consent of AUDI AG. Specifications are subject to change without notice.

"Audi", "quattro" and the four rings emblem are registered trademarks of AUDI AG. "R8" is trademark of AUDI AG.

Editorial deadline: 09/21/2007



For the sake of the environment

Printed on environmentally friendly paper (bleached without chlorine, recyclable).

Printed in Germany

© 2007 AUDI AG

2008 Audi R8
Owner's Manual
Englisch Nordamerika 11.07
282.561.423.21